

US008618692B2

(12) **United States Patent**
Adest et al.

(10) **Patent No.:** **US 8,618,692 B2**
(45) **Date of Patent:** **Dec. 31, 2013**

(54) **DISTRIBUTED POWER SYSTEM USING DIRECT CURRENT POWER SOURCES**

4,060,757 A 11/1977 McMurray
(Continued)

(75) Inventors: **Meir Adest**, Raanana (IL); **Lior Handelsman**, Givataim (IL); **Yoav Galin**, Raanana (IL); **Amir Fishelov**, Tel-Aviv (IL); **Guy Sella**, Beit Aharon (IL); **Yaron Binder**, Beit Arie (IL)

FOREIGN PATENT DOCUMENTS

CN 1309451 A 8/2001
DE 19737286 3/1999

(Continued)

(73) Assignee: **SolarEdge Technologies Ltd.**, Hod Hasharon (IL)

OTHER PUBLICATIONS

(*) Notice: Subject to any disclaimer, the term of this patent is extended or adjusted under 35 U.S.C. 154(b) by 374 days.

Extended European Search Report—EP12176089.6—Mailing date: Nov. 8, 2012.

(Continued)

(21) Appl. No.: **12/911,153**

(22) Filed: **Oct. 25, 2010**

Primary Examiner — Robert L. Deberadinis

(74) *Attorney, Agent, or Firm* — Banner & Witcoff, Ltd.

(65) **Prior Publication Data**

US 2011/0084553 A1 Apr. 14, 2011

(57) **ABSTRACT**

A distributed power system including multiple (DC) batteries each DC battery with positive and negative poles. Multiple power converters are coupled respectively to the DC batteries. Each power converter includes a first terminal, a second terminal, a third terminal and a fourth terminal. The first terminal is adapted for coupling to the positive pole. The second terminal is adapted for coupling to the negative pole. The power converter includes: (i) a control loop adapted for setting the voltage between or current through the first and second terminals, and (ii) a power conversion portion adapted to selectively either: convert power from said first and second terminals to said third and fourth terminals to discharge the battery connected thereto, or to convert power from the third and fourth terminals to the first and second terminals to charge the battery connected thereto. Each of the power converters is adapted for serial connection to at least one other power converter by connecting respectively the third and fourth terminals, thereby forming a serial string. A power controller is adapted for coupling to the serial string. The power controller includes a control part adapted to maintain current through or voltage across the serial string at a predetermined value.

Related U.S. Application Data

(63) Continuation-in-part of application No. 11/950,271, filed on Dec. 4, 2007.

(60) Provisional application No. 61/254,681, filed on Oct. 24, 2009.

(51) **Int. Cl.**
H02J 1/10 (2006.01)

(52) **U.S. Cl.**
USPC **307/58**

(58) **Field of Classification Search**
USPC 307/58
See application file for complete search history.

(56) **References Cited**

U.S. PATENT DOCUMENTS

3,369,210 A 2/1968 Manickella
3,596,229 A 7/1971 Hohorst
3,958,136 A 5/1976 Schroeder

20 Claims, 12 Drawing Sheets

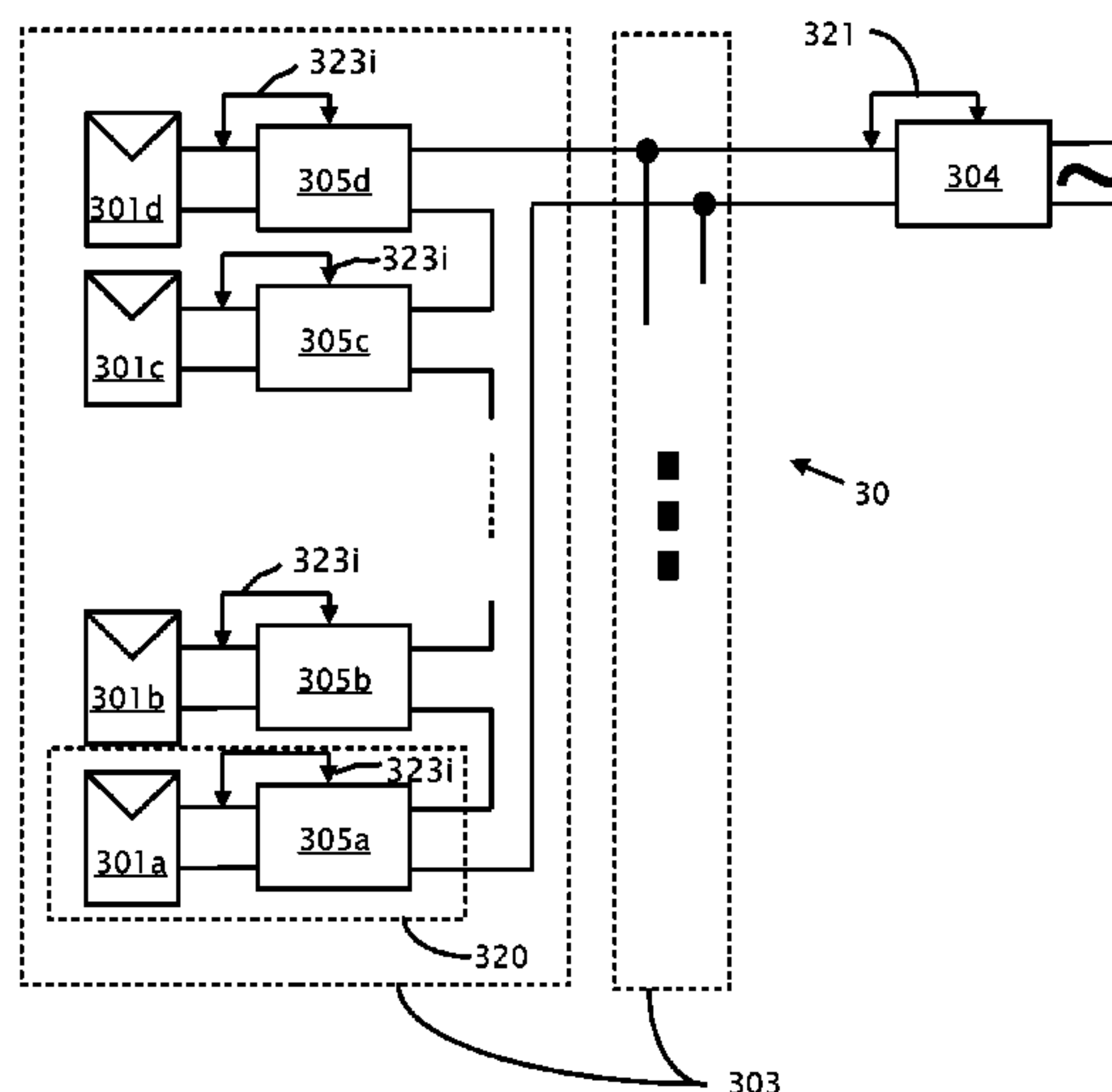

(56)

References Cited

U.S. PATENT DOCUMENTS

4,101,816 A	7/1978	Shepter	6,037,720 A	3/2000	Wong et al.
4,171,861 A	10/1979	Hohorst	6,038,148 A	3/2000	Farrington et al.
4,257,087 A	3/1981	Cuk	6,046,919 A	4/2000	Madenokouji et al.
4,452,867 A	6/1984	Conforti	6,050,779 A	4/2000	Nagao et al.
4,460,232 A	7/1984	Sotolongo	6,078,511 A	6/2000	Fasullo et al.
4,481,654 A	11/1984	Daniels et al.	6,081,104 A	6/2000	Kern
4,554,515 A	11/1985	Burson et al.	6,082,122 A	7/2000	Madenokouji et al.
4,598,330 A	7/1986	Woodworth	6,105,317 A	8/2000	Tomiuchi et al.
4,602,322 A	7/1986	Merrick	6,111,188 A	8/2000	Kurokami et al.
4,623,753 A	11/1986	Feldman et al.	6,111,391 A	8/2000	Cullen
4,637,677 A	1/1987	Barkus	6,111,767 A	8/2000	Handleman
4,641,042 A	2/1987	Miyazawa	6,163,086 A	12/2000	Choo
4,641,079 A	2/1987	Kato et al.	6,166,455 A	12/2000	Li
4,644,458 A	2/1987	Harafuji et al.	6,166,527 A	12/2000	Dwelley et al.
4,652,770 A	3/1987	Kumano	6,169,678 B1	1/2001	Kondo et al.
4,706,181 A	11/1987	Mercer	6,219,623 B1	4/2001	Wills
4,720,667 A	1/1988	Lee et al.	6,255,360 B1	7/2001	Domschke et al.
4,720,668 A	1/1988	Lee et al.	6,256,234 B1	7/2001	Keeth et al.
4,783,728 A	11/1988	Hoffman	6,259,234 B1	7/2001	Perol
RE33,057 E	9/1989	Clegg et al.	6,262,558 B1	7/2001	Weinberg
4,868,379 A	9/1989	West	6,285,572 B1	9/2001	Onizuka et al.
4,888,063 A	12/1989	Powell	6,292,379 B1	9/2001	Edevold et al.
4,888,702 A	12/1989	Gerken et al.	6,301,128 B1	10/2001	Jang et al.
4,899,269 A	2/1990	Rouzies	6,304,065 B1	10/2001	Wittenbreder
4,903,851 A	2/1990	Slough	6,320,769 B2	11/2001	Kurokami et al.
4,910,518 A	3/1990	Kim et al.	6,339,538 B1	1/2002	Handleman
4,978,870 A	12/1990	Chen et al.	6,351,130 B1	2/2002	Preiser et al.
4,987,360 A	1/1991	Thompson	6,369,462 B1	4/2002	Siri
5,045,988 A	9/1991	Gritter et al.	6,380,719 B2	4/2002	Underwood et al.
5,081,558 A	1/1992	Mahler	6,396,170 B1	5/2002	Laufenberg et al.
5,191,519 A	3/1993	Kawakami	6,433,522 B1	8/2002	Siri
5,280,232 A	1/1994	Kohl et al.	6,448,489 B2	9/2002	Kimura et al.
5,287,261 A	2/1994	Ehsani	6,452,814 B1	9/2002	Wittenbreder
5,327,071 A	7/1994	Frederick et al.	6,493,246 B2	12/2002	Suzui et al.
5,345,375 A	9/1994	Mohan	6,507,176 B2	1/2003	Wittenbreder, Jr.
5,402,060 A	3/1995	Erisman	6,531,848 B1	3/2003	Chitsazan et al.
5,446,645 A	8/1995	Shirahama et al.	6,545,211 B1	4/2003	Mimura
5,460,546 A	10/1995	Kunishi et al.	6,548,205 B2	4/2003	Leung et al.
5,493,154 A	2/1996	Smith et al.	6,587,051 B2	7/2003	Takehara et al.
5,497,289 A	3/1996	Sugishima et al.	6,590,793 B1	7/2003	Nagao et al.
5,517,378 A	5/1996	Asplund et al.	6,593,521 B2	7/2003	Kobayashi
5,530,335 A	6/1996	Decker et al.	6,608,468 B2	8/2003	Nagase
5,548,504 A	8/1996	Takehara	6,611,130 B2	8/2003	Chang
5,604,430 A	2/1997	Decker et al.	6,611,441 B2	8/2003	Kurokami et al.
5,616,913 A	4/1997	Litterst	6,628,011 B2	9/2003	Droppo et al.
5,644,219 A	7/1997	Kurokawa	6,650,031 B1	11/2003	Goldack
5,646,501 A	7/1997	Fishman et al.	6,650,560 B2	11/2003	MacDonald et al.
5,659,465 A	8/1997	Flack et al.	6,653,549 B2	11/2003	Matsushita et al.
5,686,766 A	11/1997	Tamechika	6,672,018 B2	1/2004	Shingleton
5,773,963 A	6/1998	Blanc et al.	6,678,174 B2	1/2004	Suzui et al.
5,777,515 A	7/1998	Kimura	6,690,590 B2	2/2004	Stamenic et al.
5,777,858 A	7/1998	Rodulfo	6,731,136 B2	5/2004	Knee
5,780,092 A	7/1998	Agbo et al.	6,738,692 B2	5/2004	Schienbein et al.
5,798,631 A	8/1998	Spee et al.	6,744,643 B2	6/2004	Luo et al.
5,801,519 A	9/1998	Midya et al.	6,765,315 B2	7/2004	Hammerstrom et al.
5,804,894 A	9/1998	Leeson et al.	6,768,047 B2	7/2004	Chang et al.
5,821,734 A	10/1998	Faulk	6,788,033 B2	9/2004	Vinciarelli
5,822,186 A	10/1998	Bull et al.	6,788,146 B2	9/2004	Forejt et al.
5,838,148 A	11/1998	Kurokami et al.	6,795,318 B2	9/2004	Haas et al.
5,869,956 A	2/1999	Nagao et al.	6,801,442 B2	10/2004	Suzui et al.
5,873,738 A	2/1999	Shimada et al.	6,850,074 B2	2/2005	Adams et al.
5,886,882 A	3/1999	Rodulfo	6,882,131 B1	4/2005	Takada et al.
5,886,890 A	3/1999	Ishida et al.	6,914,418 B2	7/2005	Sung
5,892,354 A	4/1999	Nagao et al.	6,919,714 B2	7/2005	Delepaut
5,905,645 A	5/1999	Cross	6,927,955 B2	8/2005	Suzui et al.
5,919,314 A	7/1999	Kim	6,933,627 B2	8/2005	Wilhelm
5,923,158 A	7/1999	Kurokami et al.	6,936,995 B2	8/2005	Kapsokavathis et al.
5,932,994 A	8/1999	Jo et al.	6,950,323 B2	9/2005	Achleitner et al.
5,933,327 A	8/1999	Leighton et al.	6,963,147 B2	11/2005	Kurokami et al.
5,945,806 A	8/1999	Faulk	6,984,967 B2	1/2006	Notman
5,949,668 A	9/1999	Schweighofer	6,984,970 B2	1/2006	Capel
5,963,010 A	10/1999	Hayashi et al.	7,030,597 B2	4/2006	Bruno et al.
5,990,659 A	11/1999	Frannhagen	7,031,176 B2	4/2006	Kotsopoulos et al.
6,002,290 A	12/1999	Avery et al.	7,042,195 B2	5/2006	Tsunetsugu et al.
6,031,736 A	2/2000	Takehara et al.	7,046,531 B2	5/2006	Zocchi et al.
			7,053,506 B2	5/2006	Alonso et al.
			7,072,194 B2	7/2006	Nayar et al.
			7,079,406 B2	7/2006	Kurokami et al.
			7,087,332 B2	8/2006	Harris

(56)

References Cited

U.S. PATENT DOCUMENTS

7,090,509 B1	8/2006	Gilliland et al.	8,111,052 B2	2/2012	Glovinsky
7,091,707 B2	8/2006	Cutler	8,116,103 B2	2/2012	Zacharias et al.
7,097,516 B2	8/2006	Werner et al.	8,138,914 B2	3/2012	Wong et al.
7,099,169 B2	8/2006	West et al.	8,184,460 B2	5/2012	O'Brien et al.
7,126,053 B2	10/2006	Kurokami et al.	8,204,709 B2	6/2012	Presher, Jr. et al.
7,126,294 B2	10/2006	Minami et al.	8,289,742 B2	10/2012	Adest et al.
7,138,786 B2	11/2006	Ishigaki et al.	8,415,937 B2	4/2013	Hester
7,148,669 B2	12/2006	Maksimovic et al.	8,436,592 B2	5/2013	Saitoh
7,158,359 B2	1/2007	Bertele et al.	2001/0023703 A1	9/2001	Kondo et al.
7,158,395 B2	1/2007	Deng et al.	2001/0034982 A1	11/2001	Nagao et al.
7,174,973 B1	2/2007	Lysaght	2002/0044473 A1	4/2002	Toyomura et al.
7,193,872 B2	3/2007	Siri	2002/0056089 A1	5/2002	Houston
7,218,541 B2	5/2007	Price et al.	2003/0058593 A1	3/2003	Bertele et al.
7,248,946 B2	7/2007	Bashaw et al.	2003/0066076 A1	4/2003	Minahan
7,256,566 B2	8/2007	Bhavaraju et al.	2003/0075211 A1	4/2003	Makita et al.
7,277,304 B2	10/2007	Stancu et al.	2003/0080741 A1	5/2003	LeRow et al.
7,281,141 B2	10/2007	Elkayam et al.	2003/0214274 A1	11/2003	Lethellier
7,282,814 B2	10/2007	Jacobs	2004/0041548 A1	3/2004	Perry
7,291,036 B1	11/2007	Daily et al.	2004/0061527 A1	4/2004	Knee
RE39,976 E	1/2008	Schiff et al.	2004/0125618 A1	7/2004	De Rooij
7,336,056 B1	2/2008	Dening	2004/0140719 A1	7/2004	Vulih et al.
7,348,802 B2	3/2008	Kasanyal et al.	2004/0169499 A1	9/2004	Huang et al.
7,352,154 B2	4/2008	Cook	2004/0201279 A1	10/2004	Templeton
7,371,963 B2	5/2008	Suenaga et al.	2004/0201933 A1	10/2004	Blanc
7,372,712 B2	5/2008	Stancu et al.	2004/0246226 A1	12/2004	Moon
7,385,380 B2	6/2008	Ishigaki et al.	2005/0002214 A1	1/2005	Deng et al.
7,385,833 B2	6/2008	Keurig	2005/0005785 A1	1/2005	Poss et al.
7,394,237 B2	7/2008	Chou et al.	2005/0017697 A1	1/2005	Capel
7,420,815 B2	9/2008	Love	2005/0057214 A1	3/2005	Matan
7,435,134 B2	10/2008	Lenox	2005/0057215 A1	3/2005	Matan
7,435,897 B2	10/2008	Russell	2005/0068820 A1	3/2005	Radosevich et al.
7,471,014 B2	12/2008	Lum et al.	2005/0099138 A1	5/2005	Wilhelm
7,504,811 B2	3/2009	Watanabe et al.	2005/0103376 A1	5/2005	Matsushita et al.
7,589,437 B2	9/2009	Henne et al.	2005/0105224 A1	5/2005	Nishi
7,600,349 B2	10/2009	Liebendorfer	2005/0121067 A1	6/2005	Toyomura et al.
7,602,080 B1	10/2009	Hadar et al.	2005/0162018 A1	7/2005	Realmuto et al.
7,605,498 B2	10/2009	Ledenev et al.	2005/0172995 A1	8/2005	Rohrig et al.
7,612,283 B2	11/2009	Toyomura et al.	2005/0226017 A1	10/2005	Kotsopoulos et al.
7,646,116 B2	1/2010	Batarseh et al.	2005/0281064 A1	12/2005	Olsen et al.
7,719,140 B2	5/2010	Ledenev et al.	2006/0001406 A1	1/2006	Matan
7,748,175 B2	7/2010	Liebendorfer	2006/0017327 A1	1/2006	Siri et al.
7,759,575 B2	7/2010	Jones et al.	2006/0034106 A1	2/2006	Johnson
7,763,807 B2	7/2010	Richter	2006/0038692 A1	2/2006	Schnetker
7,780,472 B2	8/2010	Lenox	2006/0053447 A1	3/2006	Krzyzanowski et al.
7,782,031 B2	8/2010	Qiu et al.	2006/0066349 A1	3/2006	Murakami
7,783,389 B2	8/2010	Yamada et al.	2006/0068239 A1	3/2006	Norimatsu et al.
7,787,273 B2	8/2010	Lu et al.	2006/0108979 A1	5/2006	Daniel et al.
7,804,282 B2	9/2010	Bertele	2006/0113843 A1	6/2006	Beveridge
7,812,701 B2	10/2010	Lee et al.	2006/0113979 A1	6/2006	Ishigaki et al.
7,839,022 B2	11/2010	Wolfs	2006/0118162 A1	6/2006	Saelzer et al.
7,843,085 B2	11/2010	Ledenev et al.	2006/0132102 A1	6/2006	Harvey
7,868,599 B2	1/2011	Rahman et al.	2006/0149396 A1	7/2006	Templeton
7,880,334 B2	2/2011	Evans et al.	2006/0162772 A1	7/2006	Presher, Jr. et al.
7,893,346 B2	2/2011	Nachamkin et al.	2006/0163946 A1	7/2006	Henne et al.
7,900,361 B2	3/2011	Adest et al.	2006/0171182 A1	8/2006	Siri et al.
7,919,952 B1	4/2011	Fahrenbruch	2006/0174939 A1	8/2006	Matan
7,919,953 B2	4/2011	Porter et al.	2006/0185727 A1	8/2006	Matan
7,925,552 B2	4/2011	Tarbell et al.	2006/0192540 A1	8/2006	Balakrishnan et al.
7,944,191 B2	5/2011	Xu	2006/0208660 A1	9/2006	Shinmura et al.
7,948,221 B2	5/2011	Watanabe et al.	2006/0227578 A1	10/2006	Datta et al.
7,952,897 B2	5/2011	Nocentini et al.	2006/0237058 A1	10/2006	McClintock et al.
7,960,650 B2	6/2011	Richter et al.	2007/0013349 A1	1/2007	Bassett
7,960,950 B2	6/2011	Glovinsky	2007/0044837 A1	3/2007	Simburger et al.
8,003,885 B2	8/2011	Richter et al.	2007/0075689 A1	4/2007	Kinder et al.
8,004,116 B2	8/2011	Ledenev et al.	2007/0075711 A1	4/2007	Blanc et al.
8,004,117 B2	8/2011	Adest et al.	2007/0081364 A1	4/2007	Andreyca
8,013,472 B2	9/2011	Adest et al.	2007/0147075 A1	6/2007	Bang
8,018,748 B2	9/2011	Leonard	2007/0159866 A1	7/2007	Siri
8,058,747 B2	11/2011	Avrutsky et al.	2007/0164612 A1	7/2007	Wendt et al.
8,058,752 B2	11/2011	Erickson, Jr. et al.	2007/0164750 A1	7/2007	Chen et al.
8,077,437 B2	12/2011	Mumtaz et al.	2007/0165347 A1	7/2007	Wendt et al.
8,093,756 B2	1/2012	Porter et al.	2007/0205778 A1	9/2007	Fabbro et al.
8,093,757 B2	1/2012	Wolfs	2007/0227574 A1	10/2007	Cart
8,098,055 B2	1/2012	Avrutsky et al.	2007/0236187 A1	10/2007	Wai et al.
8,102,144 B2	1/2012	Capp et al.	2007/0247877 A1	10/2007	Kwon et al.
			2007/0273342 A1	11/2007	Kataoka et al.
			2007/0290636 A1	12/2007	Beck et al.
			2008/0024098 A1	1/2008	Hojo
			2008/0080177 A1	4/2008	Chang

(56)

References Cited

U.S. PATENT DOCUMENTS

2008/0088184 A1 4/2008 Tung et al.
 2008/0097655 A1 4/2008 Hadar et al.
 2008/0106250 A1 5/2008 Prior et al.
 2008/0115823 A1 5/2008 Kinsey
 2008/0136367 A1 6/2008 Adest et al.
 2008/0143188 A1 6/2008 Adest et al.
 2008/0143462 A1 6/2008 Belisle et al.
 2008/0144294 A1 6/2008 Adest et al.
 2008/0147335 A1 6/2008 Adest et al.
 2008/0150366 A1 6/2008 Adest et al.
 2008/0164766 A1 7/2008 Adest et al.
 2008/0179949 A1 7/2008 Besser et al.
 2008/0218152 A1 9/2008 Bo
 2008/0236647 A1 10/2008 Gibson et al.
 2008/0236648 A1 10/2008 Klein et al.
 2008/0238195 A1 10/2008 Shaver et al.
 2008/0246460 A1 10/2008 Smith
 2008/0246463 A1 10/2008 Sinton et al.
 2008/0252273 A1 10/2008 Woo et al.
 2008/0303503 A1 12/2008 Wolfs
 2009/0039852 A1 2/2009 Fishelov et al.
 2009/0066399 A1 3/2009 Chen et al.
 2009/0073726 A1 3/2009 Babcock
 2009/0084570 A1 4/2009 Gherardini et al.
 2009/0097172 A1 4/2009 Bremicker et al.
 2009/0102440 A1 4/2009 Coles
 2009/0121549 A1 5/2009 Leonard
 2009/0140715 A1 6/2009 Adest et al.
 2009/0141522 A1 6/2009 Adest et al.
 2009/0145480 A1 6/2009 Adest et al.
 2009/0146667 A1 6/2009 Adest et al.
 2009/0146671 A1 6/2009 Gazit
 2009/0147554 A1 6/2009 Adest et al.
 2009/0184746 A1 7/2009 Fahrenbruch
 2009/0190275 A1 7/2009 Gilmore et al.
 2009/0206666 A1 8/2009 Sella et al.
 2009/0224817 A1 9/2009 Nakamura et al.
 2009/0237042 A1 9/2009 Glovinsky
 2009/0237043 A1 9/2009 Glovinsky
 2009/0242011 A1 10/2009 Proisy et al.
 2009/0273421 A1 11/2009 Cros et al.
 2009/0282755 A1 11/2009 Abbott et al.
 2009/0284998 A1 11/2009 Zhang et al.
 2009/0322494 A1 12/2009 Lee
 2010/0001587 A1 1/2010 Casey et al.
 2010/0052735 A1 3/2010 Burkland et al.
 2010/0085670 A1 4/2010 Palaniswami et al.
 2010/0124027 A1 5/2010 Handelsman et al.
 2010/0127571 A1 5/2010 Hadar et al.
 2010/0139743 A1 6/2010 Hadar et al.
 2010/0176773 A1 7/2010 Capel
 2010/0181957 A1 7/2010 Goeltner
 2010/0214808 A1 8/2010 Rodriguez
 2010/0244575 A1 9/2010 Coccia et al.
 2010/0269430 A1 10/2010 Haddock
 2010/0277001 A1 11/2010 Wagoner
 2010/0282290 A1 11/2010 Schwarze et al.
 2010/0294528 A1 11/2010 Sella et al.
 2010/0294903 A1 11/2010 Shmukler et al.
 2010/0297860 A1 11/2010 Shmukler et al.
 2010/0301991 A1 12/2010 Sella et al.
 2010/0308662 A1 12/2010 Schatz et al.
 2011/0006743 A1 1/2011 Fabbro
 2011/0037600 A1 2/2011 Takehara et al.
 2011/0043172 A1 2/2011 Dearn
 2011/0079263 A1 4/2011 Avrutsky
 2011/0114154 A1 5/2011 Lichy et al.
 2011/0121652 A1 5/2011 Sella et al.
 2011/0125431 A1 5/2011 Adest et al.
 2011/0133552 A1 6/2011 Binder et al.
 2011/0140536 A1 6/2011 Adest et al.
 2011/0181251 A1 7/2011 Porter et al.
 2011/0181340 A1 7/2011 Gazit
 2011/0210611 A1 9/2011 Ledenev et al.
 2011/0254372 A1 10/2011 Haines et al.

2011/0260866 A1 10/2011 Avrutsky et al.
 2011/0267859 A1 11/2011 Chapman
 2011/0271611 A1 11/2011 Maracci et al.
 2011/0273015 A1 11/2011 Adest et al.
 2011/0273016 A1 11/2011 Adest et al.
 2011/0285205 A1 11/2011 Ledenev et al.
 2011/0290317 A1 12/2011 Naumovitz et al.
 2011/0291486 A1 12/2011 Adest et al.
 2011/0316346 A1 12/2011 Porter et al.
 2012/0007613 A1 1/2012 Gazit
 2012/0019966 A1 1/2012 DeBoer
 2012/0032515 A1 2/2012 Ledenev et al.
 2012/0081009 A1 4/2012 Shteynberg et al.
 2012/0091810 A1 4/2012 Aiello et al.

FOREIGN PATENT DOCUMENTS

DE 102005030907 1/2007
 DE 102008057874 5/2010
 EP 0419093 3/1991
 EP 0420295 4/1991
 EP 0604777 7/1994
 EP 0756178 1/1997
 EP 0827254 3/1998
 EP 1330009 7/2003
 EP 1503490 2/2005
 EP 1531545 5/2005
 EP 1657557 5/2006
 EP 1657797 5/2006
 EP 1887675 2/2008
 EP 2048679 4/2010
 EP 2315328 A2 4/2011
 EP 2393178 A2 12/2011
 ES 2249147 3/2006
 ES 2249149 3/2006
 GB 2476508 A 6/2011
 JP 61065320 A 4/1986
 JP 6165320 5/1986
 JP 6165310 A 6/1994
 JP 11041832 2/1999
 JP 11103538 4/1999
 JP 11206038 A 7/1999
 JP 11289891 A 10/1999
 JP 11318042 A 11/1999
 JP 2002300735 A 10/2002
 JP 2003124492 4/2003
 JP 2003134667 5/2003
 JP 2004194500 A 7/2004
 JP 2004260944 A 9/2004
 JP 2007058845 3/2007
 WO 9313587 7/1993
 WO 9613093 5/1996
 WO 9823021 5/1998
 WO 00/00839 1/2000
 WO 0021178 4/2000
 WO 0075947 12/2000
 WO 0231517 4/2002
 WO 03050938 6/2003
 WO 03071655 8/2003
 WO 2004023278 3/2004
 WO 2004090993 10/2004
 WO 2004107543 12/2004
 WO 2005076444 8/2005
 WO 2005076445 8/2005
 WO 2006005125 1/2006
 WO 2006007198 1/2006
 WO 2006078685 7/2006
 WO 2007006564 1/2007
 WO 2007048421 5/2007
 WO 2007073951 7/2007
 WO 2007084196 7/2007
 WO 2007090476 8/2007
 WO 2007113358 10/2007
 WO 2008008528 A2 1/2008
 WO 2008125915 10/2008
 WO 2008132551 11/2008
 WO 2008132553 11/2008
 WO 2008142480 11/2008
 WO 2009007782 1/2009

(56)

References Cited

FOREIGN PATENT DOCUMENTS

WO	2009046533	A1	4/2009
WO	2009051853		4/2009
WO	2009073868		6/2009
WO	2009118682		10/2009
WO	2009118683		10/2009
WO	2009136358		11/2009
WO	2010/002960	A1	1/2010
WO	2010065043		6/2010
WO	2010065388		6/2010
WO	2010072717		7/2010
WO	2010078303	A2	7/2010
WO	2010094012	A1	8/2010
WO	2011011711		1/2011
WO	2011017721		2/2011
WO	2011023732	A2	3/2011
WO	2011059067	A1	5/2011
WO	2011074025	A1	6/2011

OTHER PUBLICATIONS

Gwon-Jong Yu et al: "Maximum power point tracking with temperature compensation of photovoltaic for air conditioning system with fuzzy controller", 19960513; 19960513-19960517, May 13, 1996, pp. 1429-1432, XP010208423.

Extended European Search Report—EP12177067.1—Mailing Date: Dec. 7, 2012.

GB Combined Search and Examination Report—GB1200423.0—Mailing date: Apr. 30, 2012.

GB Combined Search and Examination Report—GB1201499.9—Mailing date: May 28, 2012.

GB Combined Search and Examination Report—GB1201506.1—Mailing date: May 22, 2012.

Ciobotaru, et al., Control of single-stage single-phase PV inverter, Aug. 7, 2006.

International Search Report and Written Opinion for PCT/IB2007/004591 dated Jul. 5, 2010.

European Communication for EP07873361.5 dated Jul. 12, 2010.

European Communication for EP07874022.2 dated Oct. 18, 2010.

European Communication for EP07875148.4 dated Oct. 18, 2010.

Chen, et al., "A New Low-Stress Buck-Boost Converter for Universal-Input PFC Applications", IEEE Applied Power Electronics Conference, Feb. 2001, Colorado Power Electronics Center Publications.

Chen, et al., "Buck-Boost PWM Converters Having Two Independently Controlled Switches", IEEE Power Electronics Specialists Conference, Jun. 2001, Colorado Power Electronics Center Publications.

Esrarn, et al., "Comparison of Photovoltaic Array Maximum Power Point Tracking Techniques", IEEE Transactions on Energy Conversion, vol. 22, No. 2, Jun. 2007, pp. 439-449.

Walker, et al., "PhotoVoltaic DC-DC Module Integrated Converter for Novel Cascaded and Bypass Grid Connection Topologies-Design and Optimisation", 37th IEEE Power Electronics Specialists Conference, Jun. 18-22, 2006, Jeju, Korea.

Geoffrey R. Walker Affidavit re: U.S. Appl. No. 11/950,307.

Geoffrey R. Walker Affidavit re: U.S. Appl. No. 11/950,271.

International Search Report for PCT/IB2007/004610 dated Feb. 23, 2009.

International Search Report for PCT/IB2007/004584 dated Jan. 28, 2009.

International Search Report for PCT/IB2007/004586 dated Mar. 5, 2009.

International Search Report for PCT/IB2007/004643 dated Jan. 30, 2009.

International Search Report for PCT/US2008/085736 dated Jan. 28, 2009.

International Search Report for PCT/US2008/085754 dated Feb. 9, 2009.

International Search Report for PCT/US2008/085755 dated Feb. 3, 2009.

Kajihara, et al., "Model of Photovoltaic Cell Circuits Under Partial Shading", 2005 IEEE, pp. 866-870.

Knaupp, et al., "Operation of a 10 KW PV Façade with 100 W AC Photovoltaic Modules", 1996 IEEE, 25th PVSC, May 13-17, 1996, pp. 1235-1238, Washington, DC.

Alonso, et al., "Cascaded H-Bridge Multilevel Converter for Grid Connected Photovoltaic Generators with Independent Maximum Power Point Tracking of Each Solor Array", 2003 IEEE 34th, Annual Power Electronics Specialists Conference, Acapulco, Mexico, Jun. 15-19, 2003, pp. 731-735, vol. 2.

Myrzik, et al., "String and Module Integrated Inverters for Single-Phase Grid Connected Photovoltaic Systems—A Review", Power Tech Conference Proceedings, 2003 IEEE Bologna, Jun. 23-26, 2003, p. 8, vol. 2.

Chen, et al., "Predictive Digital Current Programmed Control", IEEE Transactions on Power Electronics, vol. 18, Issue 1, Jan. 2003.

Wallace, et al., "DSP Controlled Buck/Boost Power Factor Correction for Telephony Rectifiers", Telecommunications Energy Conference 2001, INTELEC 2001, Twenty-Third International, Oct. 18, 2001, pp. 132-138.

Alonso, "A New Distributed Converter Interface for PV Panels", 20th European Photovoltaic Solar Energy Conference, Jun. 6-10, 2005, Barcelona, Spain, pp. 2288-2291.

Alonso, "Experimental Results of Intelligent PV Module for Grid-Connected PV Systems", 21st European Photovoltaic Solar Energy Conference, Sep. 4-8, 2006, Dresden, Germany, pp. 2297-2300.

Enslin, "Integrated Photovoltaic Maximum Power Point Tracking Converter", IEEE Transactions on Industrial Electronics, vol. 44, No. 6, Dec. 1997, pp. 769-773.

Lindgren, "Topology for Decentralised Solar Energy Inverters with a Low Voltage AC-Bus", Chalmers University of Technology, Department of Electrical Power Engineering, EPE '99—Lausanne.

Nikraz, "Digital Control of a Voltage Source Inverter in a Photovoltaic Applications", 2004 35th Annual IEEE Power Electronics Specialists Conference, Aachen, Germany, 2004, pp. 3266-3271.

Orduz, "Evaluation Test Results of a New Distributed MPPT Converter", 22nd European Photovoltaic Solar Energy Conference, Sep. 3-7, 2007, Milan, Italy.

Palma, "A Modular Fuel Cell, Modular DC-DC Converter Concept for High Performance and Enhanced Reliability", IEEE 2007, pp. 2633-2638.

Quaschnig, "Cost Effectiveness of Shadow Tolerant Photovoltaic Systems", Berlin University of Technology, Institute of Electrical Energy Technology, Renewable Energy Section. EuroSun '96, pp. 819-824.

Roman, "Intelligent PV Module for Grid-Connected PV Systems", IEEE Transactions on Industrial Electronics, vol. 52, No. 4, Aug. 2006, pp. 1066-1073.

Roman, "Power Line Communications in Modular PV Systems", 20th European Photovoltaic Solar Energy Conference, Jun. 6-10, 2005, Barcelona, Spain, pp. 2249-2252.

Uriarte, "Energy Integrated Management System for PV Applications", 20th European Photovoltaic Solar Energy Conference, Jun. 6-10, 2005, Barcelona, Spain, pp. 2292-2295.

Walker, "Cascaded DC-DC Converter Connection of Photovoltaic Modules", IEEE Transactions on Power Electronics, vol. 19, No. 4, Jul. 2004, pp. 1130-1139.

Matsui, et al., "A New Maximum Photovoltaic Power Tracking Control Scheme Based on Power Equilibrium at DC Link", IEEE, 1999, pp. 804-809.

International Preliminary Report on Patentability for PCT/IB2008/055092 dated Jun. 8, 2010.

International Search Report for PCT/IB2008/055092 dated Sep. 8, 2009.

International Search Report and Opinion of International Patent Application WO2009136358 (PCT/IB2009/051831), dated Sep. 16, 2009.

PCT/IB2010/052287 International Search Report and Written Opinion dated Sep. 2, 2010.

UK Intellectual Property office, Combined Search and Examination Report for GB1100450.4 under Sections 17 and 18 (3), Jul. 14, 2011.

(56)

References Cited

OTHER PUBLICATIONS

Jain, et al., "A Single-Stage Grid Connected Inverter Topology for Solar PV Systems with Maximum Power Point Tracking", IEEE Transactions on Power Electronics, vol. 22, No. 5, Sep. 2007, pp. 1928-1940.

Lynch, et al., "Flexible Der Utility Interface System: Final Report", Sep. 2004-May 2006, Northern Power Systems, Inc., Waitsfield, Vermont B. Kroposki, et al., National Renewable Energy Laboratory Golden, Colorado Technical Report NREL/TP—560-39876, Aug. 2006.

Schimpf, et al., "Grid Connected Converters for Photovoltaic, State of the Art, Ideas for improvement of Transformerless Inverters", NORPIE/2008, Nordic Workshop on Power and Industrial Electronics, Jun. 9-11, 2008.

Sandia Report SAND96-2797 IUC-1290 Unlimited Release, Printed Dec. 1996, "Photovoltaic Power Systems and The National Electrical Code: Suggested Practices", by John Wiles, Southwest Technology Development Institute New Mexico State University Las Cruces, NM. United Kingdom Intellectual Property Office, Combined Search and Examination Report Under Sections 17 and 18(3), GB1020862.7, dated Jun. 16, 2011.

QT Technical Application Papers, "ABB Circuit-Breakers for Direct current Applications", ABB SACE S.p.A., An ABB Group Company, L.V. Breakers, Via Baioni, 35, 24123 Bergamo-Italy, Tel.: +39 035.395.111—Telefax: +39 035.395.306-433.

Woyte, et al., "Mains Monitoring and Protection in a European Context", 17th European Photovoltaic Solar Energy Conference and Exhibition, Munich, Germany, Oct. 22-26, 2001, ACHIM, WOYTE, et al., pp. 1-4.

"Implementation and testing of Anti-Islanding Algorithms for IEEE 929-2000 Compliance of Single Phase Photovoltaic Inverters", Raymond M. Hudson, Photovoltaic Specialists Conference, 2002. Conference Record of the Twenty-Ninth IEEE, May 19-24, 2002. Fairchild Semiconductor, Application Note 9016, IGBT Basics 1, by K.S. OH Feb. 1, 2001.

"Disconnect Switches in Photovoltaic Applications", ABB, Inc., Low Voltage Control Products & Systems, 1206 Hatton Road, Wichita Falls, TX 86302, Phone 888-385-1221, 940-397-7085, ISXU301197B0201, Nov. 2009.

Walker, "A DC Circuit Breaker for an Electric Vehicle Battery Pack", Australasian Universities Power Engineering Conference and IEAust Electric Energy Conference, Sep. 26-29, 1999.

Combined Search and Examination Report for GB1018872.0 dated Apr. 15, 2011, 2 pages.

International Search Report and Opinion of International Patent Application PCT/2009/051221, dated Oct. 19, 2009.

International Search Report and Opinion of International Patent Application PCT/2009/051222, dated Oct. 7, 2009.

Communication in EP07874025.5 dated Aug. 17, 2011.

IPRP for PCT/IB2008/055095 dated Jun. 8, 2010, with Written Opinion.

ISR for PCT/IB2008/055095 dated Apr. 30, 2009.

IPRP for PCT/IL2007/001064 dated Mar. 17, 2009, with Written Opinion dated Mar. 25, 2008.

ISR for PCT/IL07/01064 dated Mar. 25, 2008.

IPRP for PCT/IB2007/004584 dated Jun. 10, 2009, with Written Opinion.

IPRP for PCT/IB2007/004586 dated Jun. 10, 2009, with Written Opinion.

IPRP for PCT/IB2007/004591 dated Jul. 13, 2010, with Written Opinion.

IPRP for PCT/IB2007/004610 dated Jun. 10, 2009, with Written Opinion.

IPRP for PCT/IB2007/004643 dated Jun. 10, 2009, with Written Opinion.

Written Opinion for PCT/IB2008/055092 submitted with IPRP dated Jun. 8, 2010.

IPRP for PCT/US2008/085754 dated Jun. 8, 2010, with Written Opinion dated Jan. 21, 2009.

IPRP for PCT/US2008/085755 dated Jun. 8, 2010, with Written Opinion dated Jan. 20, 2009.

IPRP for PCT/IB2009/051221 dated Sep. 28, 2010, with Written Opinion.

IPRP for PCT/IB2009/051222 dated Sep. 28, 2010, with Written Opinion.

IPRP for PCT/IB2009/051831 dated Nov. 9, 2010, with Written Opinion.

IPRP for PCT/US2008/085736 dated Jun. 7, 2011, with Written Opinion.

IPRP for PCT/IB2010/052287 dated Nov. 22, with Written Opinion.

ISR for PCT/IB2010/052413 dated Sep. 7, 2010.

UK Intellectual Property Office, Application No. GB1109618.7, Patents Act 1977, Examination Report Under Section 18(3), Sep. 16, 2011.

UK Intellectual Property Office, Patents Act 1977: Patents Rules Notification of Grant: Patent Serial No. GB2480015, Nov. 29, 2011.

Hou, et al., Application of Adaptive Algorithm of Solar Cell Battery Charger, Apr. 2004.

Stamenic, et al., "Maximum Power Point Tracking for Building Integrated Photovoltaic Ventilation Systems", 2000.

Informal Comments to the International Search Report dated Dec. 3, 2009.

Walker, et al. "PV String Per-Module Maximum Power Point Enabling Converters", School of Information Technology and Electrical Engineering The University of Queensland, Sep. 28, 2003.

Walker, "Cascaded DC-DC Converter Connection of Photovoltaic Modules", 33rd Annual IEEE Power Electronics Specialists Conference. PESC 2002. Conference Proceedings. CAIRNS, Queensland, Australia, Jun. 23-27, 2002; [Annual Power Electronics Specialists Conference], New York, NY: IEEE US, vol. 1, Jun. 23, 2002, pp. 24-29, XP010596060 ISBN: 978-0-7803-7262-7, figure 1.

Baggio, "Quasi-ZVS Activity Auxiliary Commutation Circuit for Two Switches Forward Converter", 32nd Annual IEEE Power Electronics Specialists Conference. PESC 2001. Conference Proceedings. Vancouver, Canada, Jun. 17-21, 2001; [Annual Power Electronics Specialists Conference] New York, NY: IEEE, US.

Llic, "Interleaved Zero-Current-Transition Buck Converter", IEEE Transactions on Industry Applications, IEEE Service Center, Piscataway, NJ, US, vol. 43, No. 6, Nov. 1, 2007, pp. 1619-1627, XP011197477 ISSN: 0093-9994, pp. 1619-1922.

Lee: "Novel Zero-Voltage-Transition and Zero-Current-Transition Pulse-Width-Modulation Converters", Power Electronics Specialists Conference, 1997, PESC '97, Record, 28th Annual IEEE St. Louis, MO, USA, Jun. 22-27, 1997, New York, NY, USA IEEE, US, vol. 1, Jun. 22, 1997, pp. 233-239, XP010241553, ISBN: 978-0-7803-3840-1, pp. 233-236.

Sakamoto, "Switched Snubber for High-Frequency Switching Converters", Electronics & Communications in Japan, Part 1—Communications, Wiley, Hoboken, NJ, US, vol. 76, No. 2, Feb. 1, 1993, pp. 30-38, XP000403018 ISSN: 8756-6621, pp. 30-35.

Duarte, "A Family of ZVX-PWM Active-Clamping DC-to-DC Converters: Synthesis, Analysis and Experimentation", Telecommunications Energy Conference, 1995, INTELEC '95, 17th International The Hague, Netherlands, Oct. 29-Nov. 1, 1995, New York, NY, US, IEEE, US, Oct. 29, 1995, pp. 502-509, XP010161283 ISBN: 978-0-7803-2750-4 p. 503-504.

Geoffrey R. Walker Affidavit re: U.S. Appl. No. 11/950,307, submitted for U.S. Appl. No. 11/950,271 on Mar. 9, 2010.

Geoffrey R. Walker Affidavit re: U.S. Appl. No. 11/950,271, submitted for U.S. Appl. No. 11/950,271 on Mar. 9, 2010.

QT Technical Application Papers, "ABB Circuit-Breakers for Direct current Applications", ABB SACE S.p.A., An ABB Group Company, L.V. Breakers, Via Baioni, 35, 24123 Bergamo-Italy, Tel.: +39 035.395.111—Telefax: +39 035.395.306-433, Sep. 2007.

Gao, et al., "Parallel-Connected Solar PV System to Address Partial and Rapidly Fluctuating Shadow Conditions", IEEE Transactions on Industrial Electronics, vol. 56, No. 5, May 2009, pp. 1548-1556.

"Study of Energy Storage Capacitor Reduction for Single Phase PWM Rectifier", Ruxi Wang et al., Virginia Polytechnic Institute and State University, Feb. 2009.

(56)

References Cited

OTHER PUBLICATIONS

“Multilevel Inverters: A Survey of Topologies, Controls, and Applications”, José Rodriguez et al., IEEE Transactions on Industrial Electronics, vol. 49, No. 4, Aug. 2002.

Satcon Solstice—Satcon Solstice 100 kW System Solution Sheet—2010.

John Xue, “PV Module Series String Balancing Converters”, University of Queensland—School of Infoamtion Technology & Electrical Engineering, Nov. 6, 2002.

Robert W. Erickson, “Future of Power Electronics for Photovoltaics”, IEEE Applied Power Electronics Conference, Feb. 2009.

GB Combined Search and Examination Report—GB1203763.6—Mailing date: Jun. 25, 2012.

Mohammad Reza Amini et al., “Quasi REsonant DC Link Inverter with a Simple Auxiliary Circuit”, Journal of Power Electronics, vol. 11, No. 1, Jan. 2011.

Khairy Fathy et al., “A Novel Quasi-Resonant Snubber-Assisted ZCS-PWM DC-DC Converter with High Frequency Link”, Journal of Power Electronics, vol. 7, No. 2, Apr. 2007.

Cheng K.W.E., “New Generation of Switched Capacitor Converters”, Department of Electrical Engineering, The Hong Kong Polytechnic University, Hung Hom, Hong Kong, Power Electronics Conference, 1998, PESC 98.

Per Karlsson, “Quasi Resonant DC Link Converters—Analysis and Design for a Battery Charger Application”, Universitetstryckeriet, Lund University, 1999, ISBN 91-88934-14-4.

Hsiao Sung-Hsin et al., “ZCS Switched-Capacitor Bidirectional Converters with Secondary Output Power Amplifier for Biomedical Applications”, Power Electronics Conference (IPEC) Jun. 21, 2010.

Yuang-Shung Lee et al., “A Novel QR ZCS Switched-Capacitor Bidirectional Converter”, IEEE, 2007.

Antti Tolvanen et al., “Seminar on Solar Simulation Standards and Measurement Principles”, May 9, 2006 Hawaii.

J.A. Eikelboom and M.J. Jansen, “Characterisation of PV Modules of New Generations—Results of tests and simulations”, Jun. 2000.

Yeong-Chau Kuo et al., “Novel Maximum-Power-Point-Tracking Controller for Photovoltaic Energy Conversion System”, IEEE Transactions on Industrial Electronics, Vol. 48, No. 3, Jun. 2001.

C. Liu et al., “Advanced Algorithm for MPPT Control of Photovoltaic Systems”, Canadian Solar Buildings Conference, Montreal, Aug. 20-24, 2004.

Chihchiang Hua and Chihming Shen, “Study of Maximum Power Tracking Techniques and Control of DC/DC Converters for Photovoltaic Power System”, IEEE 1998.

Tore Skjellnes et al., “Load sharing for parallel inverters without communication”, Nordic Workshop in Power and Industrial Electronics, Aug. 12-14, 2002.

Giorgio Spiazzi et al., “A New Family of Zero-Current-Switching Variable Frequency dc-dc Converters”, IEEE 2000.

Nayar, C.V., M. Ashari and W.W.L. Keerthiphala, “A Gridinteractive Photovoltaic Uninterruptible Power Supply System Using Battery Storage and a Back up Diesel Generator”, IEEE Transactions on Energy Conversion, vol. 15, No. 3, Sep. 2000, pp. 348-353.

Ph. Strauss et al., “AC coupled PV Hybrid systems and Micro Grids-state of the art and future trends”, 3rd World Conference on Photovoltaic Energy Conversion, Osaka, Japan May 11-18, 2003.

Nayar, C.V., abstract, Power Engineering Society Summer Meeting, 2000. IEEE, 2000, pp. 1280-1282 vol. 2.

D. C. Martins et al., “Analysis of Utility Interactive Photovoltaic Generation System using a Single Power Static Inverter”, Asian J. Energy Environ., vol. 5, Issue 2, (2004), pp. 115-137.

Rafael C. Beltrame et al., “Decentralized Multi String PV System With Integrated ZVT Cell”, Congresso Brasileiro de Automática/12 a 16-setembro-2010, Bonito-MS.

Sergio Busquets-Monge et al., “Multilevel Diode-clamped Converter for Photovoltaic Generators With Independent Voltage Control of Each Solar Array”, IEEE Transactions on Industrial Electronics, Vol. 55, No. 7, Jul. 2008.

Soeren Baekhoej Kjaer et al., “A Review of Single-Phase Grid-Connected Inverters for Photovoltaic Modules”, IEEE Transactions on Industry Applications, Vol. 41, No. 5, Sep./Oct. 2005.

Office Action—JP 2011-539491—Mailing date: Mar. 26, 2013.

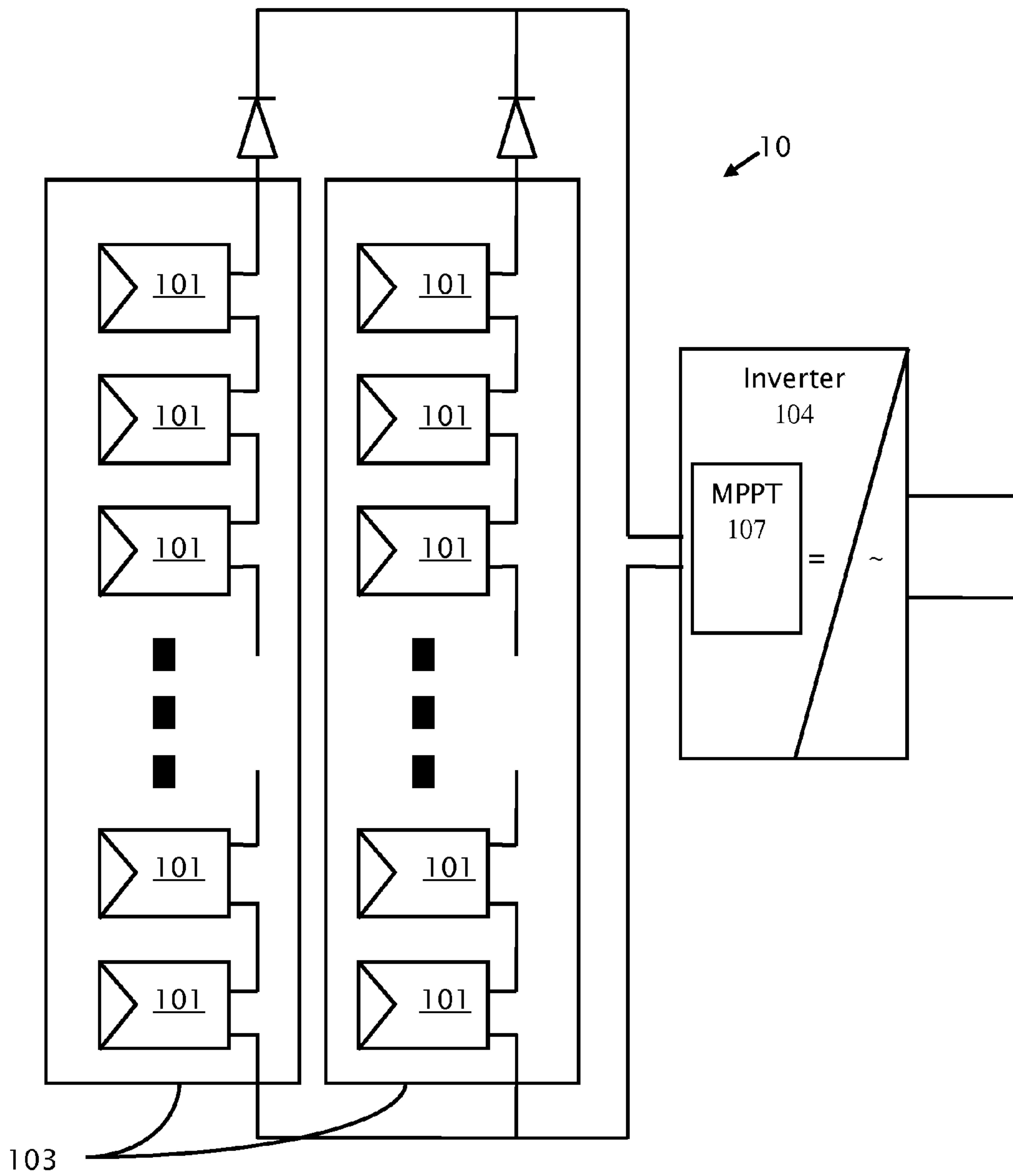

Fig. 1 Conventional Art

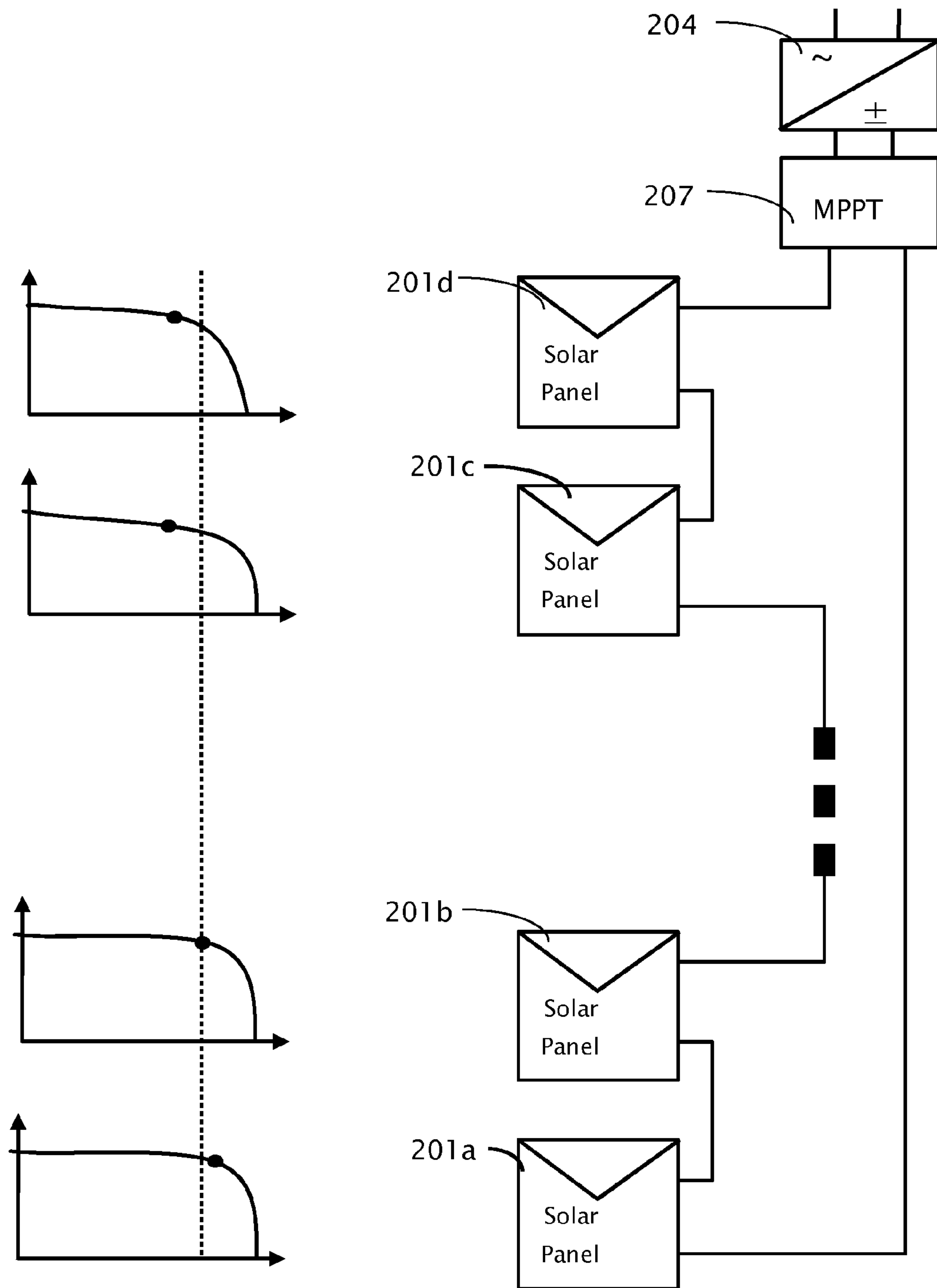

Fig. 2 Conventional Art

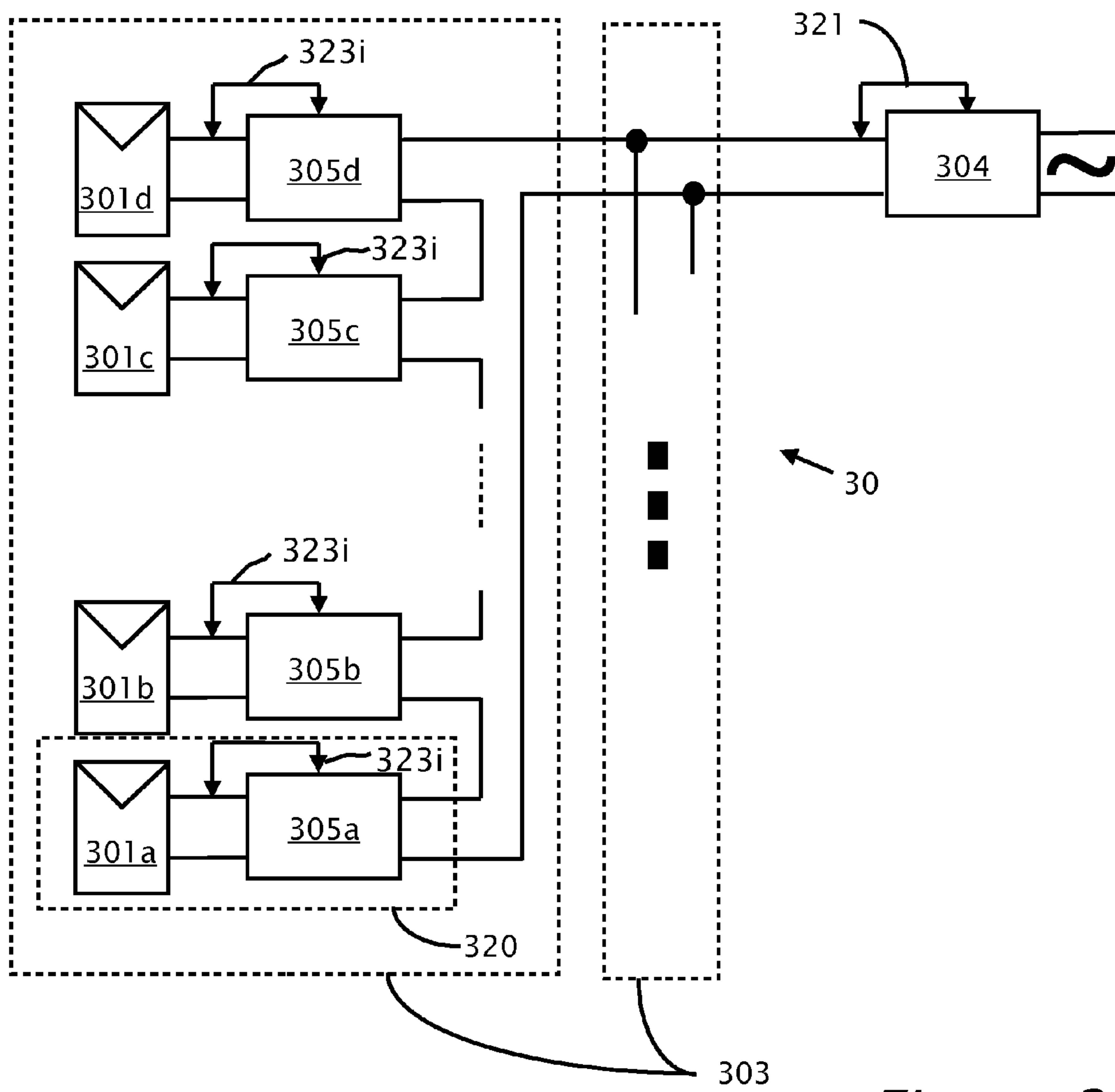

Figure 3

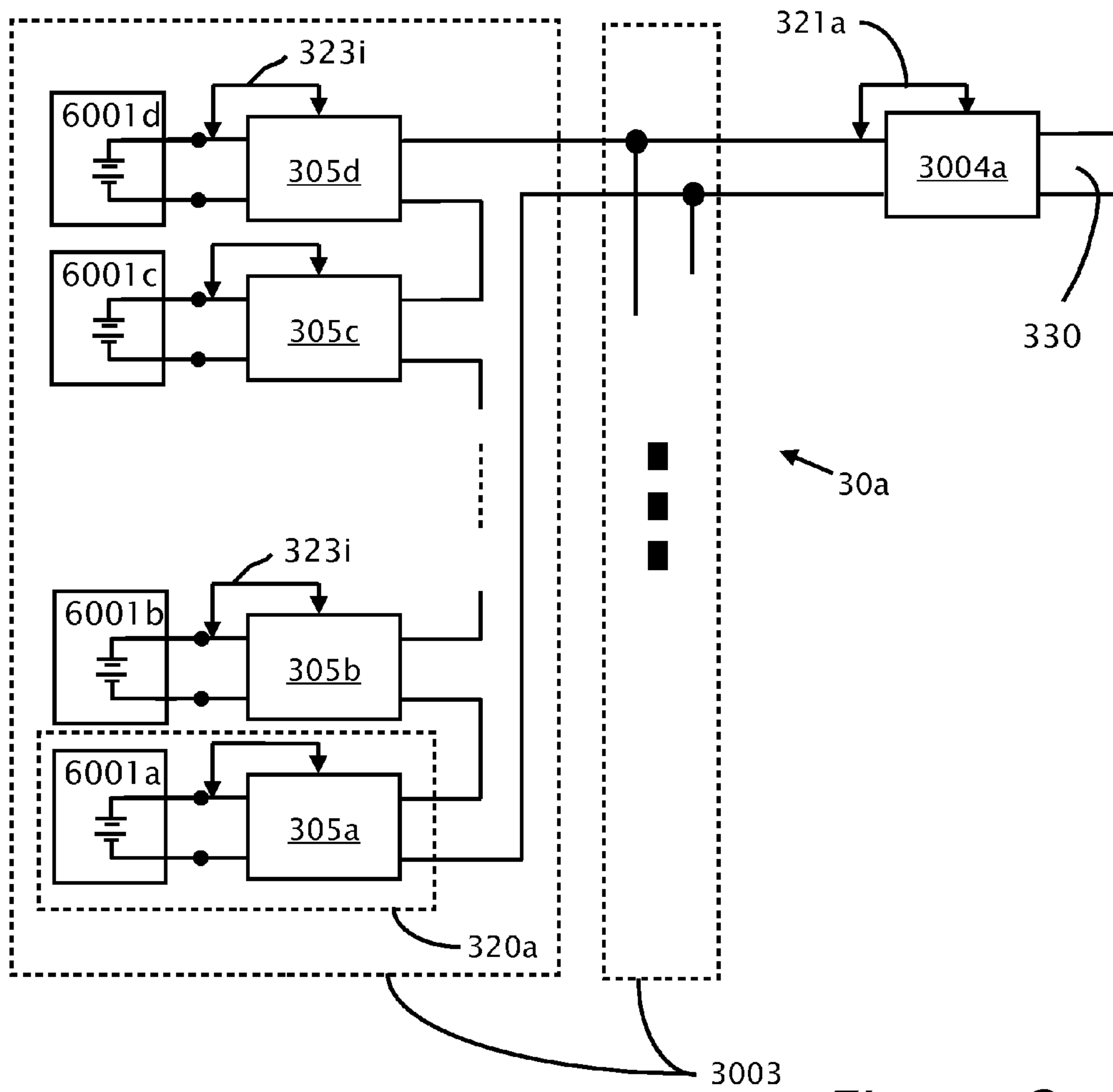

Figure 3a

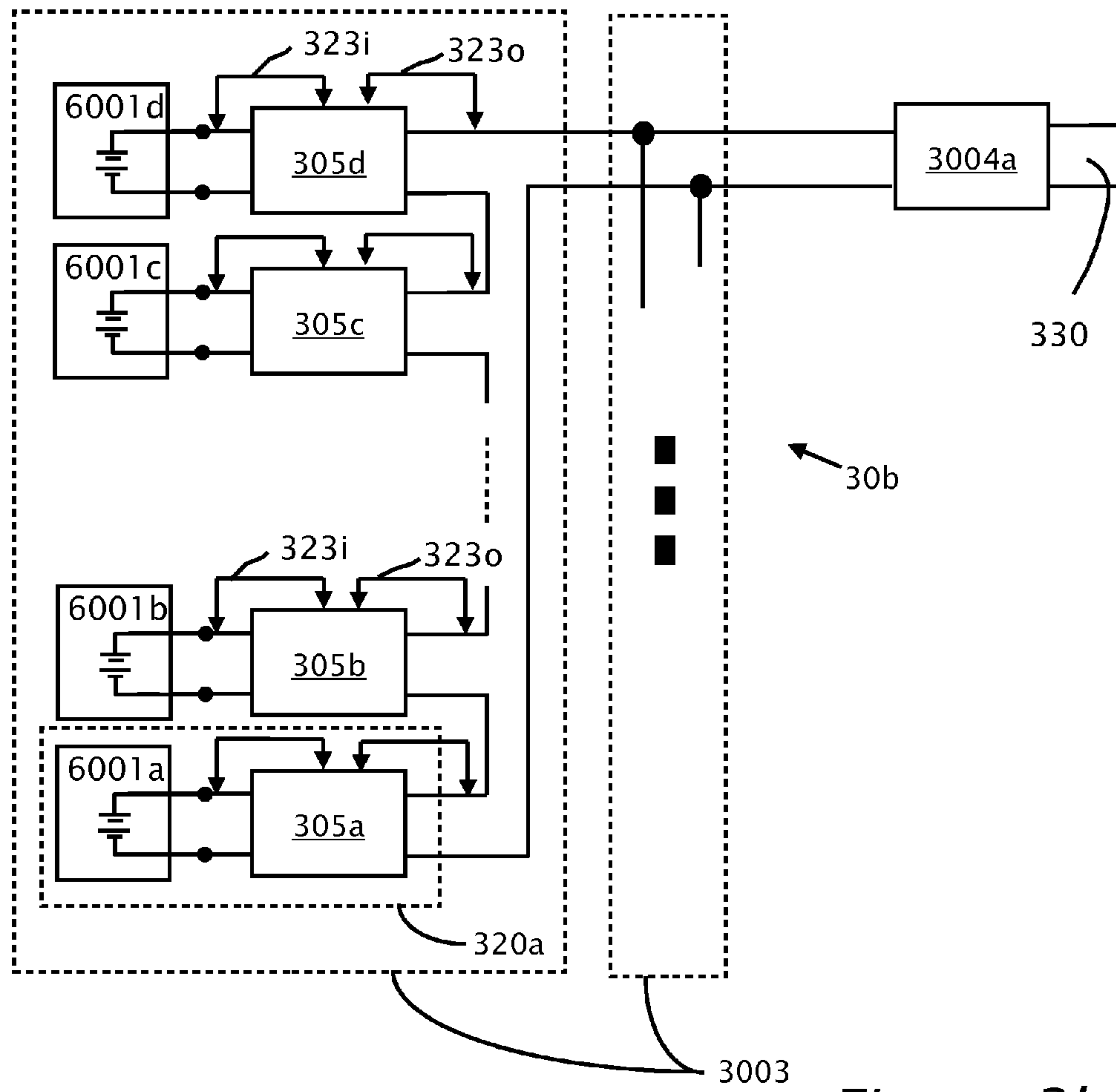

Figure 3b

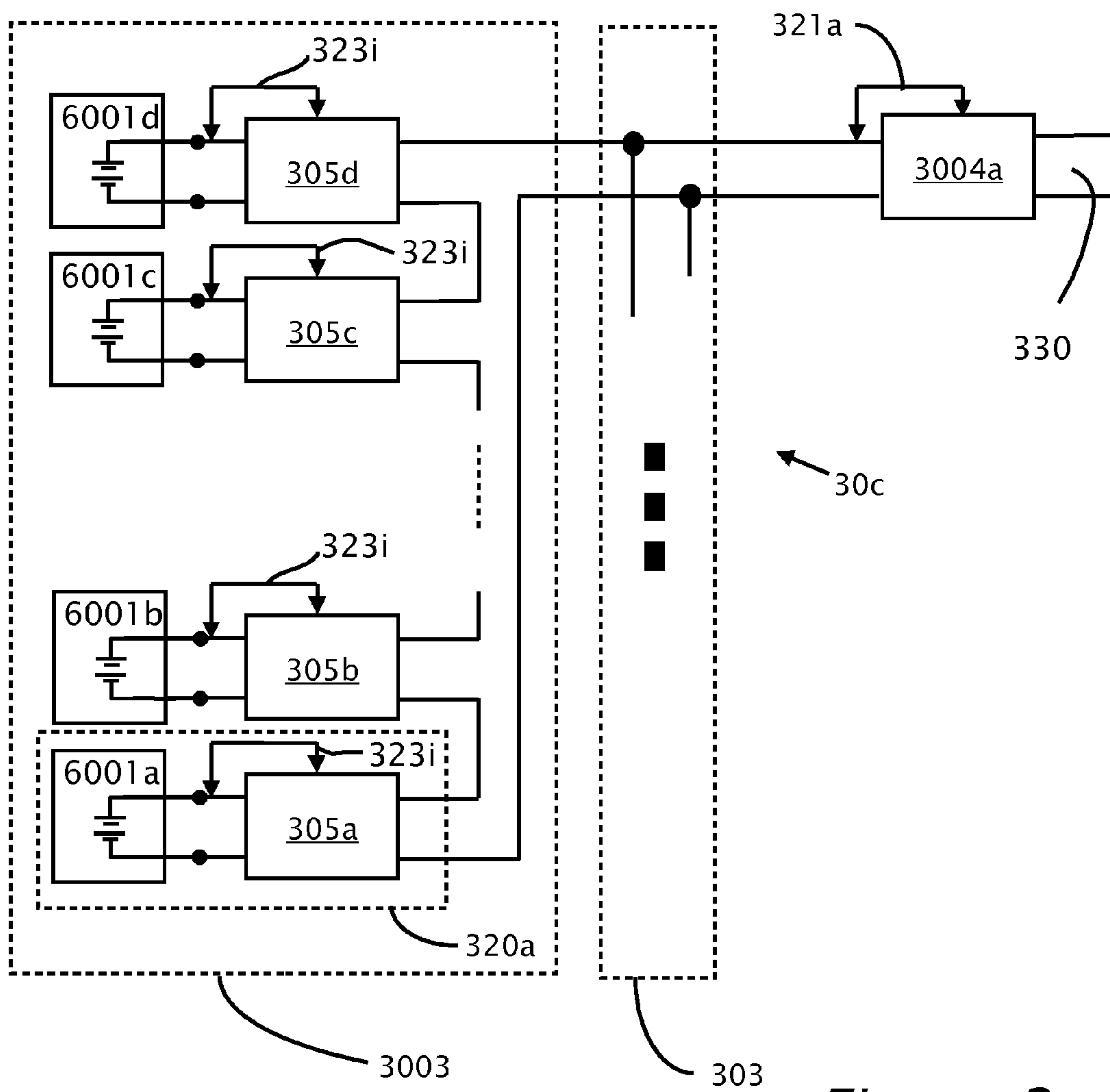

Figure 3c

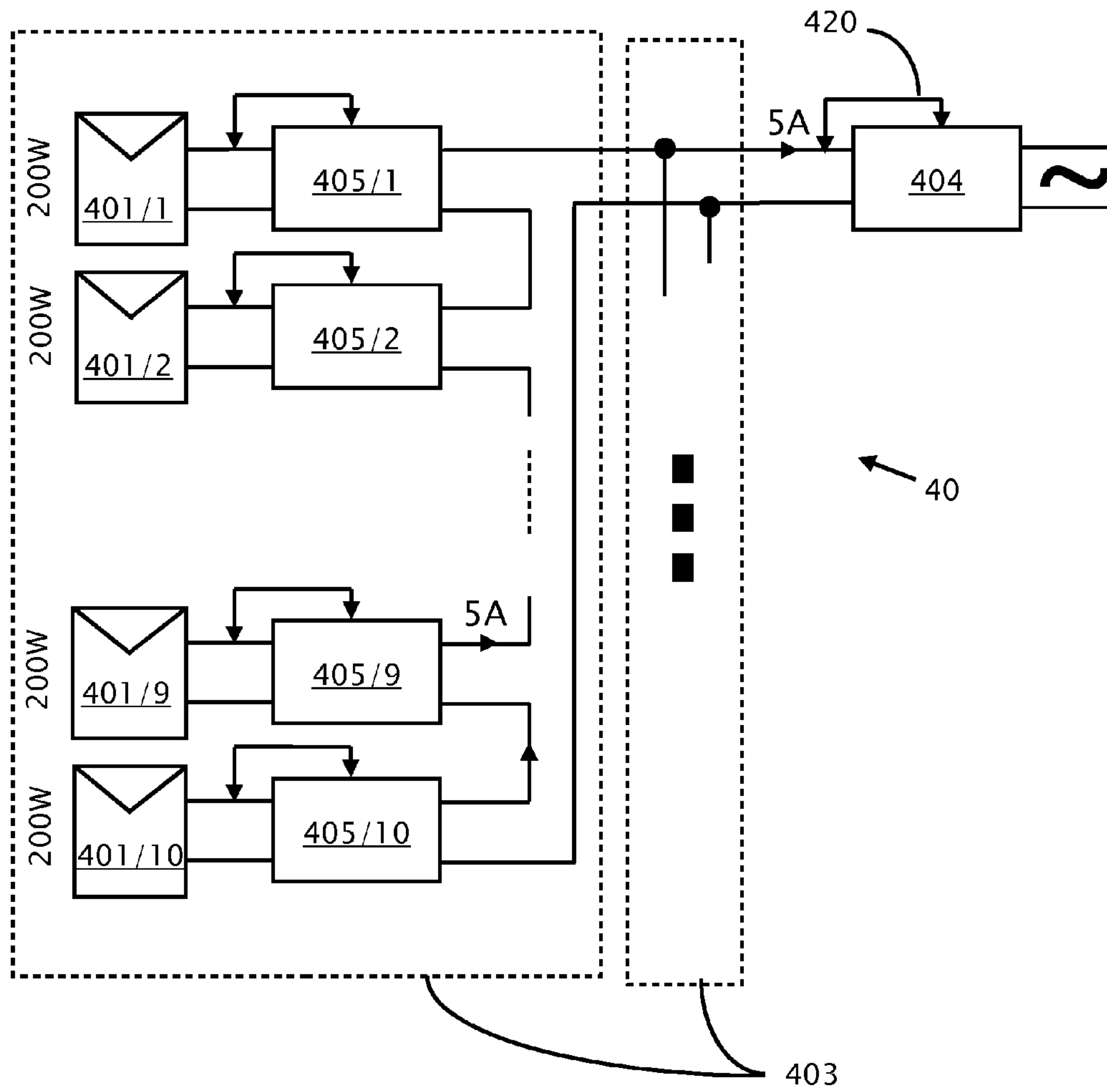

Figure 4A

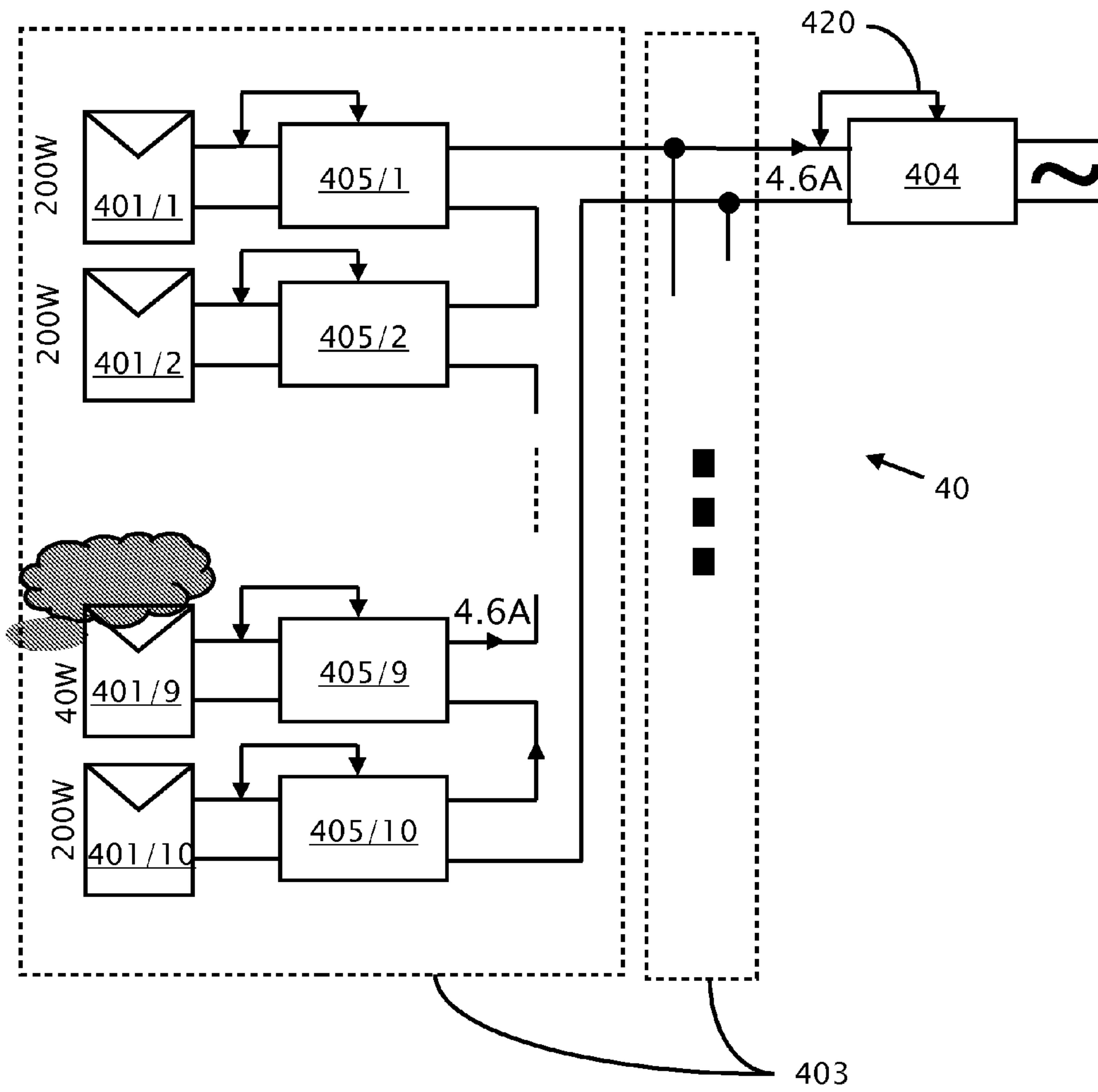

Figure 4B

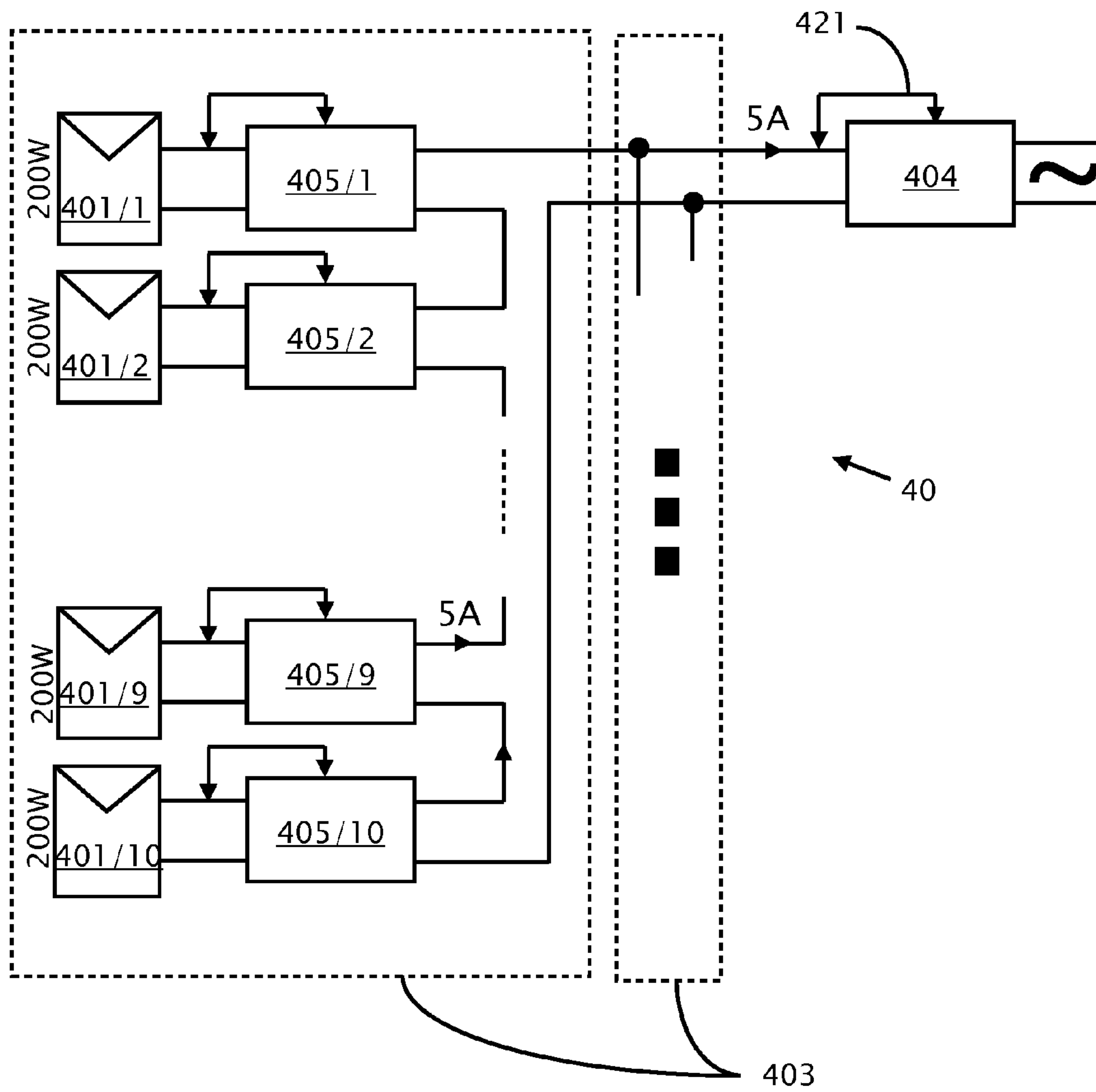

Figure 4C

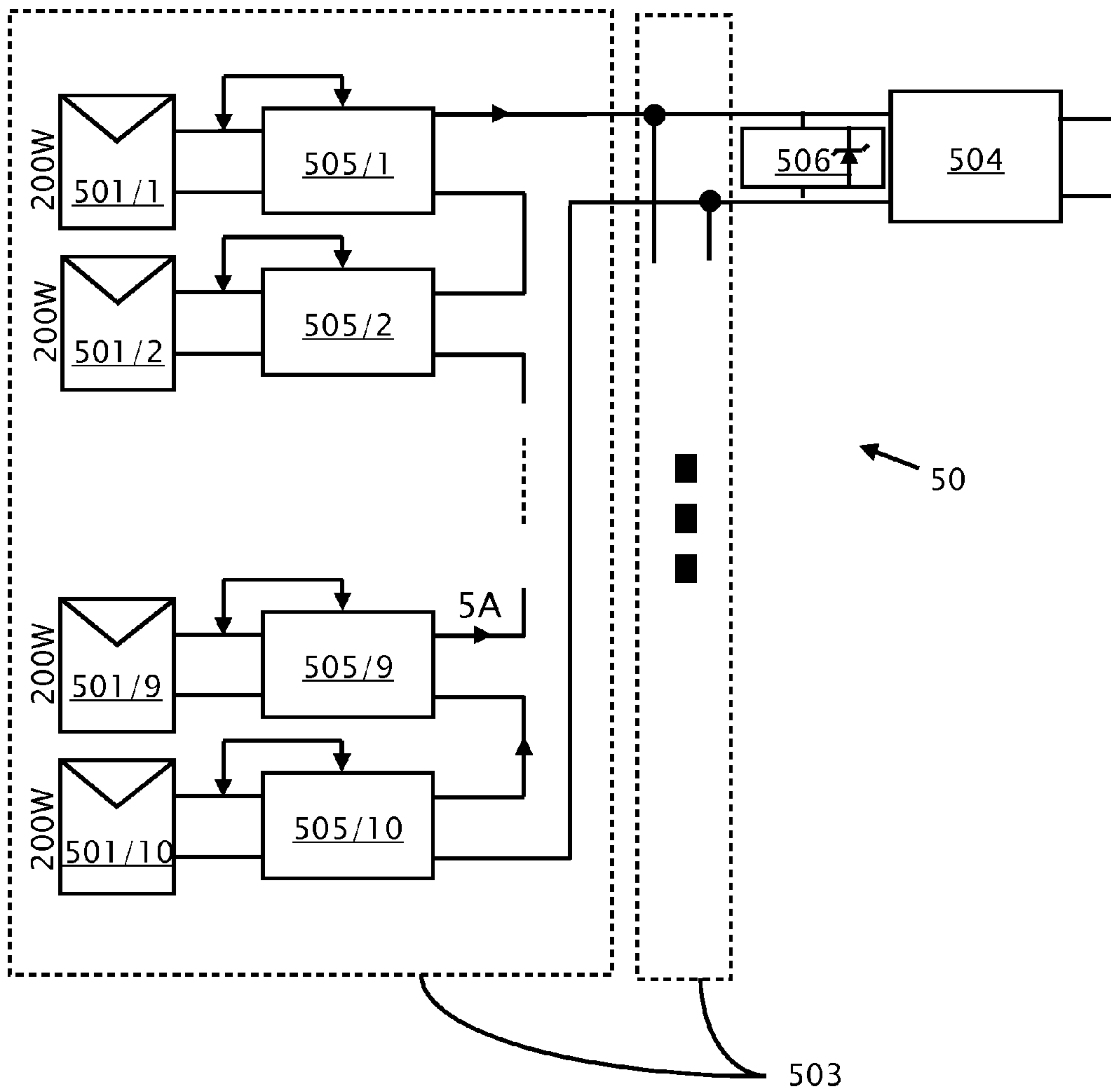

Figure 5

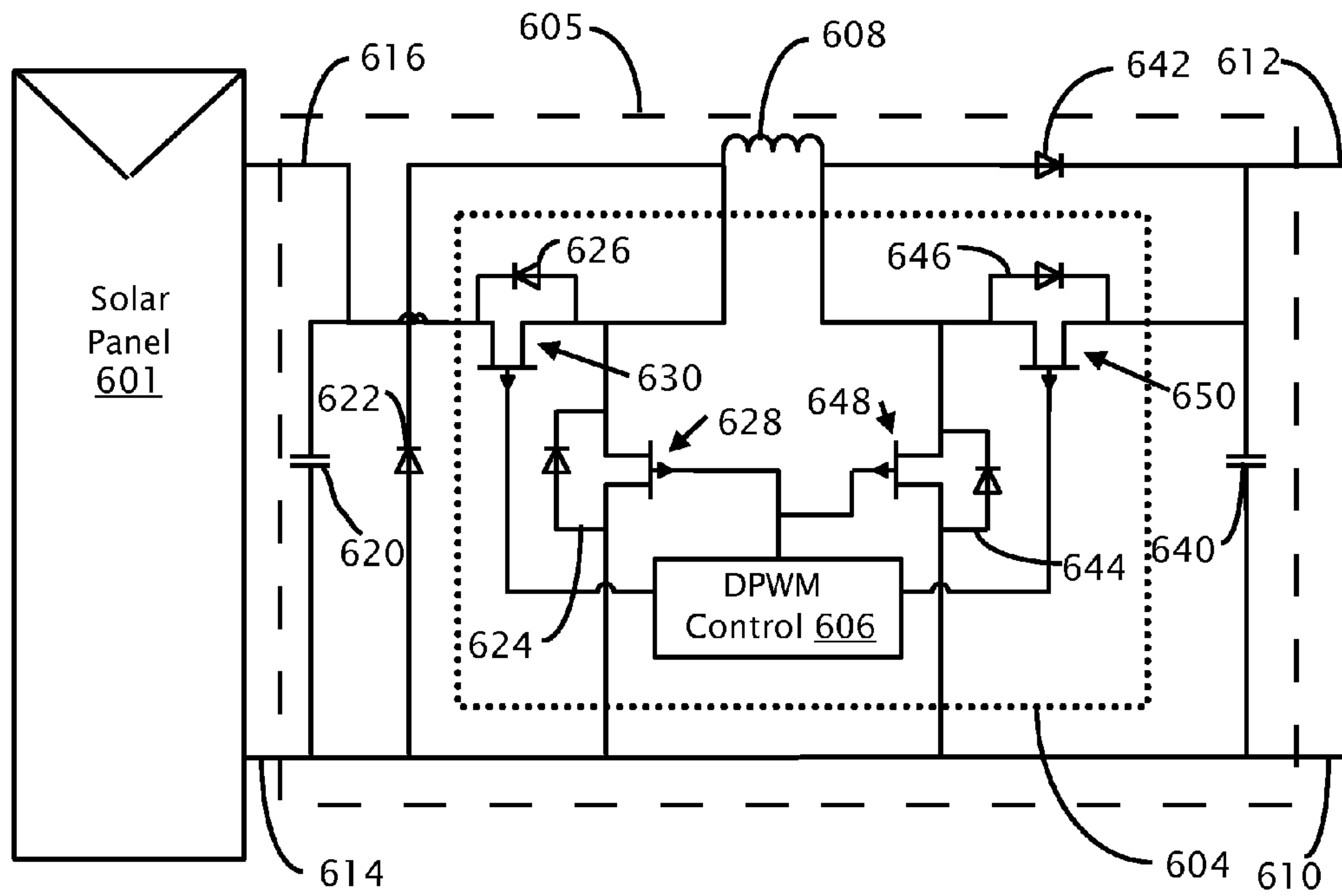

Figure 6

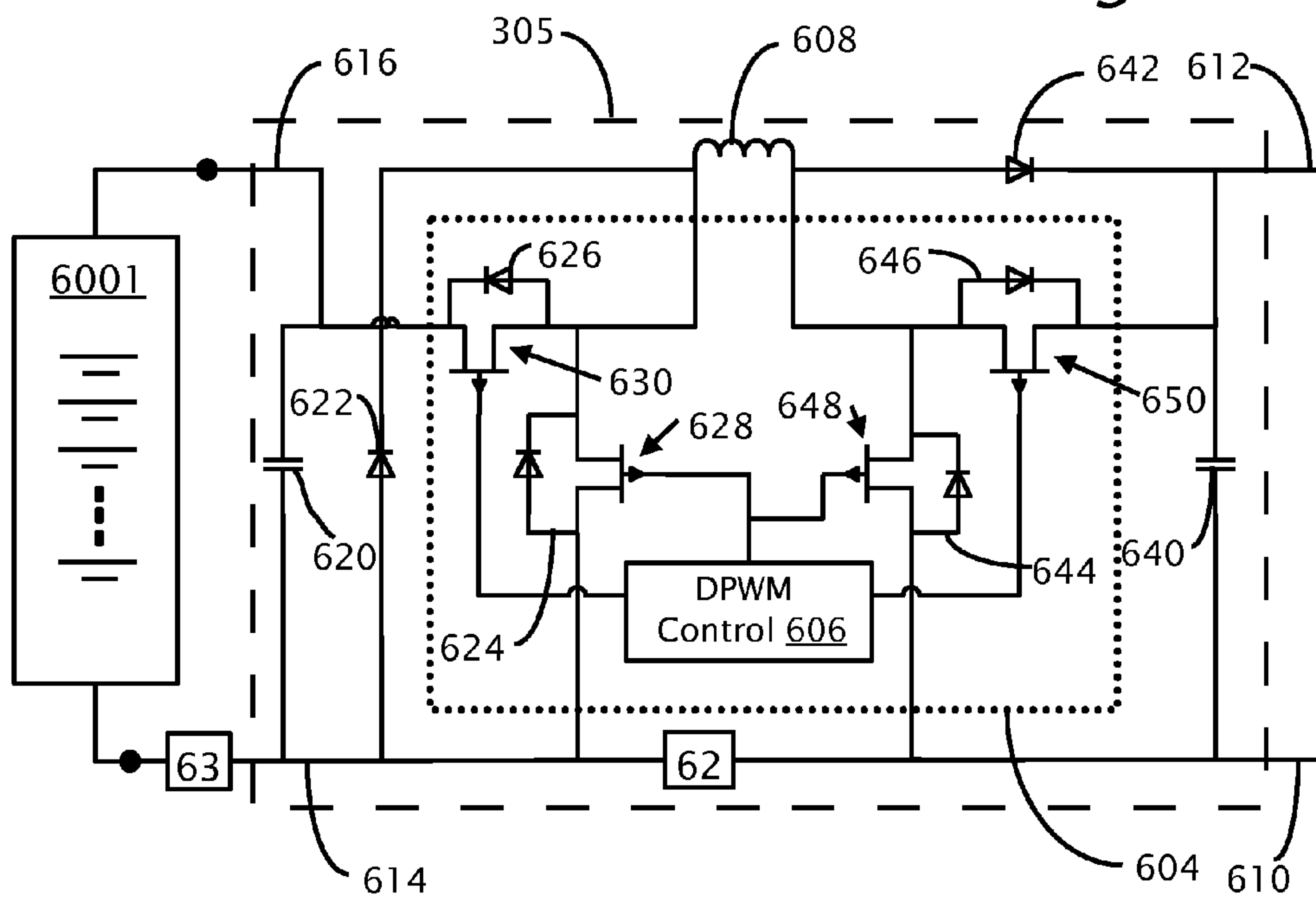

Figure 6a

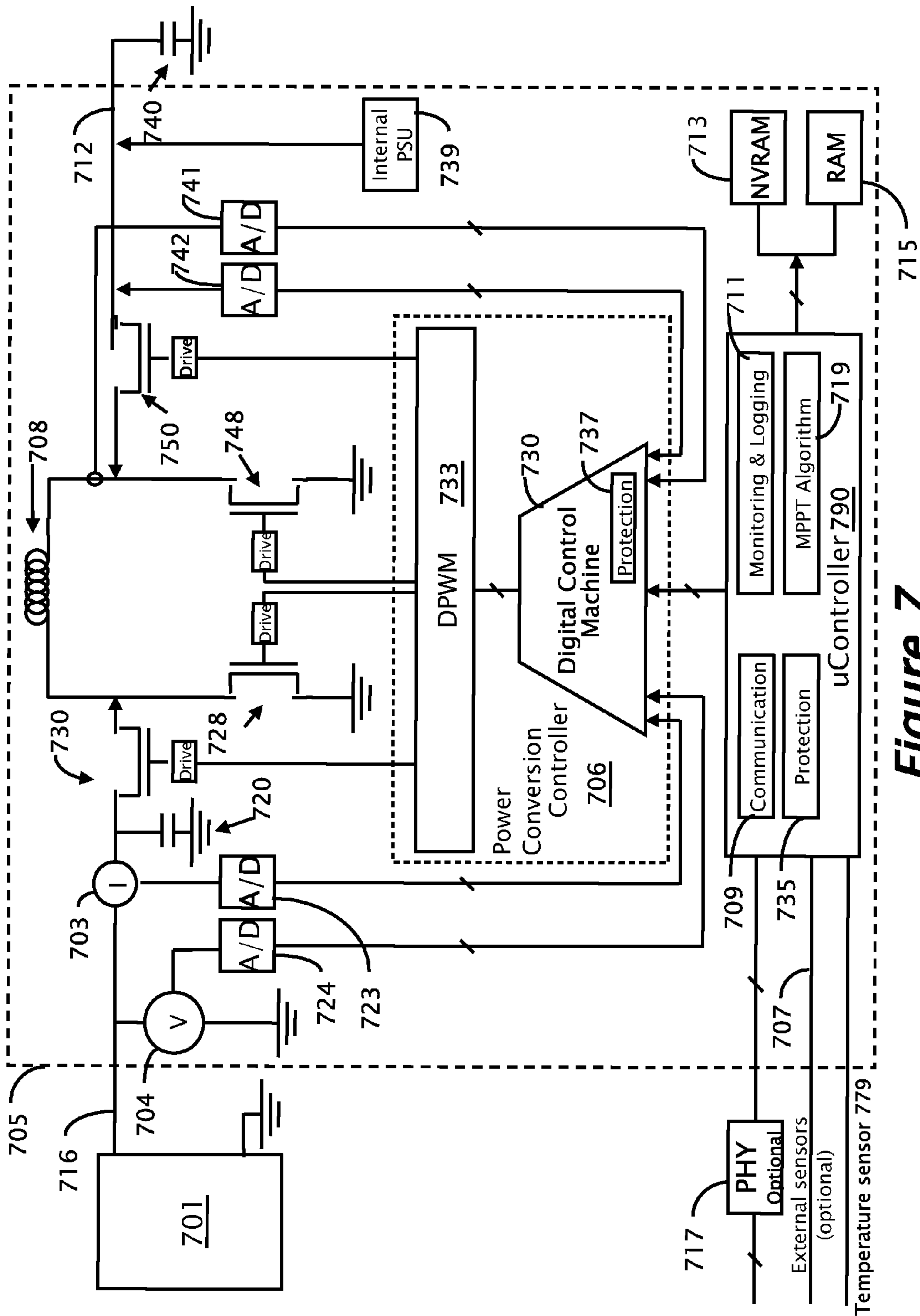

Figure 7

DISTRIBUTED POWER SYSTEM USING DIRECT CURRENT POWER SOURCES

CROSS REFERENCE TO RELATED APPLICATIONS

The present application is a continuation-in-part application of U.S. patent application Ser. No. 11/950,271 filed Dec. 4, 2007 by the same inventors. The present application has the benefit of U.S. 61/254,681 filed on Oct. 24, 2009 by the same inventors the disclosure of which is included herein.

BACKGROUND

1. Technical Field

The field of the invention relates generally to power production from distributed DC power sources, and more particularly to management of distributed DC power sources in series installations.

2. Description of Related Art

The recent increased interest in renewable energy has led to increased research in systems for distributed generation of energy, such as photovoltaic cells (PV), fuel cells, batteries (e.g., for hybrid cars), etc. Various topologies have been proposed for connecting these power sources to the load, taking into consideration various parameters, such as voltage/current requirements, operating conditions, reliability, safety, costs, etc. For example, most of these sources provide low voltage output (normally a few volts for one cell, or a few tens of volts for serially connected cells), so that many of them need to be connected serially to achieve the required operating voltage. Conversely, a serial connection may fail to provide the required current, so that several strings of serial connections may need to be connected in parallel to provide the required current.

It is also known that power generation from each of these sources depends on manufacturing, operating, and environmental conditions. For example, various inconsistencies in manufacturing may cause two identical sources to provide different output characteristics. Similarly, two identical sources may react differently to operating and/or environmental conditions, such as load, temperature, etc. In practical installations, different source may also experience different environmental conditions, e.g., in solar power installations some panels may be exposed to full sun, while others be shaded, thereby delivering different power output. In a multiple-battery installation, some of the batteries may age differently, thereby delivering different power output. While these problems and the solutions provided by the subject invention are applicable to any distributed power system, the following discussion turns to solar energy so as to provide better understanding by way of a concrete example.

A conventional installation of solar power system **10** is illustrated in FIG. 1. Since the voltage provided by each individual solar panel **101** is low, several panels are connected in series to form a string of panels **103**. For a large installation, when higher current is required, several strings **103** may be connected in parallel to form the overall system **10**. The solar panels are mounted outdoors, and their leads are connected to a maximum power point tracking (MPPT) module **107** and then to an inverter **104**. The MPPT **107** is typically implemented as part of the inverter **104**. The harvested power from the DC sources is delivered to the inverter **104**, which converts the fluctuating direct-current (DC) into alternating-current (AC) having a desired voltage and frequency, which is usually 110V or 220V at 60 Hz, or 220V at 50 Hz (It is interesting to note the even in the US many inverters produce

220V, which is then split into two 110V feeds in the electric box). The AC current from the inverter **104** may then be used for operating electric appliances or fed to the power grid. Alternatively, if the installation is not tied to the grid, the power extracted from the inverter may be directed to a conversion and charge/discharge circuit to store the excess power created as charge in batteries. In case of a battery-tied application, the inversion stage might be skipped altogether, and the DC output of the MPPT stage **107** may be fed into the charge/discharge circuit.

As noted above, each solar panel **101** supplies relatively very low voltage and current. The problem facing the solar array designer is to produce a standard AC current at 120V or 220V root-mean-square (RMS) from a combination of the low voltages of the solar panels. The delivery of high power from a low voltage requires very high currents, which cause large conduction losses on the order of the second power of the current (I^2). Furthermore, a power inverter, such as the inverter **104**, which is used to convert DC current to AC current, is most efficient when its input voltage is slightly higher than its output RMS voltage multiplied by the square root of 2. Hence, in many applications, the power sources, such as the solar panels **101**, are combined in order to reach the correct voltage or current. The most common method connects the power sources in series in order to reach the desirable voltage and in parallel in order to reach the desirable current, as shown in FIG. 1. A large number of the panels **101** are connected into a string **103** and the strings **103** are connected in parallel to the power inverter **104**. The panels **101** are connected in series in order to reach the minimal voltage required for the inverter. Multiple strings **103** are connected in parallel into an array to supply higher current, so as to enable higher power output.

While this configuration is advantageous in terms of cost and architecture simplicity, several drawbacks have been identified in the literature for such architecture. One recognized drawback is inefficiencies cause by non-optimal power draw from each individual panel, as explained below. As explained above, the output of the DC power sources is influenced by many conditions. Therefore, to maximize the power draw from each source, one needs to draw the combination of voltage and current that provides the peak power for the currently prevailing conditions. As conditions change, the combination of voltage and current draw may need to be changed as well.

FIG. 2 illustrates one serial string of DC sources, e.g., solar panels **201a-201d**, connected to MPPT circuit **207** and inverter **204**. The current versus voltage (IV) characteristics plotted (**210a-210d**) to the left of each DC source **201**. For each DC source **201**, the current decreases as the output voltage increases. At some voltage value the current goes to zero, and in some applications may assume a negative value, meaning that the source becomes a sink. Bypass diodes are used to prevent the source from becoming a sink. The power output of each source **201**, which is equal to the product of current and voltage ($P=I*V$), varies depending on the voltage drawn from the source. At a certain current and voltage, close to the falling off point of the current, the power reaches its maximum. It is desirable to operate a power generating cell at this maximum power point. The purpose of the MPPT is to find this point and operate the system at this point so as to draw the maximum power from the sources.

In a typical, conventional solar panel array, different algorithms and techniques are used to optimize the integrated power output of the system **10** using the MPPT module **107**. The MPPT module **107** receives the current extracted from all of the solar panels together and tracks the maximum power

3

point for this current to provide the maximum average power such that if more current is extracted, the average voltage from the panels starts to drop, thus lowering the harvested power. The MPPT module **107** maintains a current that yields the maximum average power from the overall system **10**.

However, since the sources **201a-201d** are connected in series to a single MPPT **207**, the MPPT must select a single point, which would be somewhat of an average of the MPP of the serially connected sources. In practice, it is very likely that the MPPT would operate at an I-V point that is optimum to only a few or none of the sources. In the example of FIG. 2, the selected point is the maximum power point for source **201b**, but is off the maximum power point for sources **201a**, **201c** and **201d**. Consequently, the arrangement is not operated at best achievable efficiency.

Turning back to the example of a solar system **10** of FIG. 1, fixing a predetermined constant output voltage from the strings **103** may cause the solar panels to supply lower output power than otherwise possible. Further, each string carries a single current that is passed through all of the solar panels along the string. If the solar panels are mismatched due to manufacturing differences, aging or if they malfunction or are placed under different shading conditions, the current, voltage and power output of each panel will be different. Forcing a single current through all of the panels of the string causes the individual panels to work at a non-optimal power point and can also cause panels which are highly mismatched to generate "hot spots" due to the high current flowing through them. Due to these and other drawbacks of conventional centralized methods, the solar panels have to be matched properly. In some cases external diodes are used to bypass the panels that are highly mismatched. In conventional multiple string configurations all strings have to be composed of exactly the same number of solar panels and the panels are selected of the same model and must be installed at exactly the same spatial orientation, being exposed to the same sunlight conditions at all times. This is difficult to achieve and can be very costly.

BRIEF SUMMARY

According to embodiments of the present invention there is provided a distributed power system including multiple (DC) batteries each DC battery with positive and negative poles. Multiple power converters are coupled respectively to the DC batteries. Each power converter includes a first terminal, a second terminal, a third terminal and a fourth terminal. The first terminal is adapted for coupling to the positive pole. The second terminal is adapted for coupling to the negative pole. The power converter includes: (i) a control loop adapted for setting the voltage between or current through the first and second terminals, and (ii) a power conversion portion adapted to selectively either: convert power from said first and second terminals to said third and fourth terminals to discharge the battery connected thereto, or to convert power from the third and fourth terminals to the first and second terminals to charge the battery connected thereto. Each of the power converters is adapted for serial connection to at least one other power converter by connecting respectively the third and fourth terminals, thereby forming a serial string. A power controller is adapted for coupling to the serial string. The power controller includes a control part adapted to maintain current through or voltage across the serial string at a predetermined value. The control part may maintain voltage across the serial string at a predetermined value or the control part may maintain current through the serial string at a predetermined value. The power controller may include a bi-directional DC/AC inverter or bi-directional DC/DC converter.

4

The power converters may function as a current source, voltage regulator or trickle charge source. The distributed power system may further include multiple photovoltaic panels; multiple DC-DC converters. Each of the DC-to-DC converters may include input terminals coupled to a respective DC photovoltaic panels and output terminals coupled in series to the other DC-to-DC converters, thereby forming a second serial string. A control loop sets the voltage and/or current at the input terminals of the DC-to-DC converter according to predetermined criteria. A power conversion portion converts the power received at the input terminals to an output power at the output terminals. The serial string and the second serial string are connectible in parallel to form parallel-connected strings. A power controller may be adapted for coupling in parallel to the parallel-connected strings, the power controller including a control part adapted to maintain current through or voltage across the parallel connected strings at a predetermined value. The power controller may be off-grid (not connected to the grid) or connected to the grid. The photovoltaic panels may provide electrical power for charging the batteries.

According to embodiments of the present invention there is provided a distributed power system including multiple (DC) batteries each DC battery with positive and negative poles. Multiple power converters are coupled respectively to the DC batteries. Each power converter includes a first terminal, a second terminal, a third terminal and a fourth terminal. The first terminal is adapted for coupling to the positive pole. The second terminal is adapted for coupling to the negative pole. The power converter includes a first control loop configured to set either current through or voltage between the first and second terminals, and a second control loop configured set either current through or voltage between the third and fourth terminals; and (iii) a power conversion portion adapted to selectively either: convert power from the first and second terminals to the third and fourth terminals to discharge the battery connected thereto, or to convert power from the third and fourth terminals to the first and second terminals to charge the battery connected thereto; wherein each of the power converters is adapted for serial connection to at least one other power converter by connecting respectively the third and fourth terminals, thereby forming a serial string. The distributed power system may further include multiple photovoltaic panels and multiple DC-DC converters. Each of the DC-to-DC converters may include input terminals coupled to a respective DC photovoltaic panels and output terminals coupled in series to the other DC-to-DC converters, thereby forming a second serial string. A control loop sets the voltage and/or current at the input terminals of the DC-to-DC converter according to predetermined criteria. A power conversion portion converts the power received at the input terminals to an output power at the output terminals. The serial string and the second serial string are connectible in parallel to form parallel-connected strings. The power controller is selectable either off-grid or connected to grid. The photovoltaic panels may provide electrical power for charging the batteries. A communications interface between the power controller and the power converters may be used for controlling charging and discharging of the batteries.

BRIEF DESCRIPTION OF THE DRAWINGS

The invention is herein described, by way of example only, with reference to the accompanying drawings, wherein:

FIG. 1 illustrates a conventional centralized power harvesting system using DC power sources.

5

FIG. 2 illustrates current versus voltage characteristic curves for one serial string of DC sources.

FIG. 3 illustrates a distributed power harvesting system, according to aspects of the invention, using DC power sources.

FIG. 3a-3c shows a variations of distributed power systems using DC batteries according to a different embodiments of the present invention.

FIGS. 4A and 4B illustrate the operation of the system of FIG. 3 under different conditions, according to aspects of the invention.

FIG. 4C illustrates an embodiment of the invention wherein the inverter controls the input current.

FIG. 5 illustrates a distributed power harvesting system, according to other aspects of the invention, using DC power sources.

FIG. 6 illustrates an exemplary DC-to-DC converter according to aspects of the invention.

FIG. 6a shows a slightly modified DC-DC converter based on the DC-DC converter shown in FIG. 6, according to an embodiment of the present invention.

FIG. 7 illustrates a power converter, according to aspects of the invention including control features of the aspects of the invention.

DETAILED DESCRIPTION

Reference will now be made in detail to embodiments of the present invention, examples of which are illustrated in the accompanying drawings, wherein like reference numerals refer to the like elements throughout. The embodiments are described below to explain the present invention by referring to the figures.

Before explaining embodiments of the invention in detail, it is to be understood that the invention is not limited in its application to the details of design and the arrangement of the components set forth in the following description or illustrated in the drawings. The invention is capable of other embodiments or of being practiced or carried out in various ways. Also, it is to be understood that the phraseology and terminology employed herein is for the purpose of description and should not be regarded as limiting.

The topology provided by the subject invention solves many of the problems associated with, and has many advantages over, the conventional art topologies. For example, the inventive topology enables serially connecting mismatched power sources, such as mismatched solar panels, panel of different models and power ratings, and even panels from different manufacturers and semiconductor materials. It allows serial connection of sources operating under different conditions, such as, e.g., solar panels exposed to different light or temperature conditions. It also enables installations of serially connected panels at different orientations or different sections of the roof or structure. This and other features and advantages will become apparent from the following detailed description. Aspects of the present invention provide a system and method for combining power from multiple DC power sources into a single power supply. According to aspects of the present invention, each DC power source is associated with a DC-DC power converter. Modules formed by coupling the DC power sources to their associated converters are coupled in series to provide a string of modules. The string of modules is then coupled to an inverter having its input voltage fixed. A maximum power point control loop in each converter harvests the maximum power from each DC power source and transfers this power as output from the power converter. For each converter, substantially all the input power is con-

6

verted to the output power, such that the conversion efficiency may be 90% or higher in some situations. Further, the controlling is performed by fixing the input current or input voltage of the converter to the maximum power point and allowing output voltage of the converter to vary. For each power source, one or more sensors perform the monitoring of the input power level to the associated converter. In some aspects of the invention, a microcontroller may perform the maximum power point tracking and control in each converter by using pulse width modulation to adjust the duty cycle used for transferring power from the input to the output.

One aspect of the present invention provides a greater degree of fault tolerance, maintenance and serviceability by monitoring, logging and/or communicating the performance of each solar panel. In one aspect of the invention, the microcontroller that is used for maximum power point tracking, may also be used to perform the monitoring, logging and communication functions. These functions allow for quick and easy troubleshooting during installation, thereby significantly reducing installation time. These functions are also beneficial for quick detection of problems during maintenance work. Aspects of the present invention allow easy location, repair, or replacement of failed solar panels. When repair or replacement is not feasible, bypass features of the current invention provide increased reliability.

In one aspect, the present invention relates to arrays of solar cells where the power from the cells is combined. Each converter may be attached to a single solar cell, or a plurality of cell connected in series, in parallel, or both, e.g., parallel connection of strings of serially connected cells. In one embodiment each converter is attached to one panel of photovoltaic strings. However, while applicable in the context of solar power technology, the aspects of the present invention may be used in any distributed power network using DC power sources. For example, they may be used in batteries with numerous cells or hybrid vehicles with multiple fuel cells on board. The DC power sources may be solar cells, solar panels, electrical fuel cells, electrical batteries, and the like. Further, although the discussion below relates to combining power from an array of DC power sources into a source of AC voltage, the aspects of the present invention may also apply to combining power from DC sources into another DC voltage.

FIG. 3 illustrates a distributed power harvesting configuration 30, according to an embodiment of the present invention. Configuration 30 enables connection of multiple power sources, for example solar panels 301a-301d, to a single power supply. In one aspect of the invention, the series string of all of the solar panels may be coupled to an inverter 304. In another aspect of the invention, several serially connected strings of solar panels may be connected to a single inverter 304. The inverter 304 may be replaced by other elements, such as, e.g., a charging regulator for charging a battery bank.

In configuration 30, each solar panel 301a-301d is connected to a separate power converter circuit 305a-305d. One solar panel together with its associated power converter circuit forms a module, e.g., module 320. Each converter 305a-305d adapts optimally to the power characteristics of the connected solar panel 301a-301d and transfers the power efficiently from converter input to converter output. The converters 305a-305d can be buck converters, boost converters, buck/boost converters, flyback or forward converters, etc. The converters 305a-305d may also contain a number of component converters, for example a serial connection of a buck and a boost converter. Each converter 305a-305d includes a control loop 323i that receives a feedback signal, not from the converter's output current or voltage, but rather

from the converter's input coming from the solar panel **301**. An example of such a control loop is a maximum power point tracking (MPPT) loop. The MPPT loop in the converter locks the input voltage and current from each solar panel **301a-301d** to its optimal power point.

Conventional DC-to-DC converters may have a wide input voltage range at their input and an output voltage that is predetermined and fixed. In these conventional DC-to-DC voltage converters, a controller within the converter monitors the current or voltage at the input, and the voltage at the output. The controller determines the appropriate pulse width modulation (PWM) duty cycle to fix the output voltage to the predetermined value by increasing the duty cycle if the output voltage drops. Accordingly, the conventional converter includes a feedback loop that closes on the output voltage and uses the output voltage to further adjust and fine tune the output voltage from the converter. As a result of changing the output voltage, the current extracted from the input is also varied.

In the converters **305a-305d**, according to aspects of the present invention, a controller within the converter **405** monitors the voltage and current at the converter input and determines the PWM in such a way that maximum power is extracted from the attached panel **301a-301d**. The controller of the converter **405** dynamically tracks the maximum power point at the converter input. In the aspects of the present invention, the feedback loop is closed on the input power in order to track maximum input power rather than closing the feedback loop on the output voltage as performed by conventional DC-to-DC voltage converters.

As a result of having a separate MPPT circuit in each converter **305a-305d**, and consequently for each solar panel **301a-301d**, each string **303** in the embodiment shown in FIG. **3** may have a different number or different brand of panels **301a-301d** connected in series. The circuit of FIG. **3** continuously performs MPPT on the output of each solar panel **301a-301d** to react to changes in temperature, solar radiance, shading or other performance factors that impact that particular solar panel **301a-301d**. As a result, the MPPT circuit within the converters **305a-305d** harvests the maximum possible power from each panel **301a-301d** and transfers this power as output regardless of the parameters impacting the other solar panels.

As such, the aspects of the invention shown in FIG. **3** continuously track and maintain the input current and the input voltage to each converter at the maximum power point of the DC power source providing the input current and the input voltage to the converter. The maximum power of the DC power source that is input to the converter is also output from the converter. The converter output power may be at a current and voltage different from the converter input current and voltage. The output current and voltage from the converter are responsive to requirements of the series connected portion of the circuit.

In one aspect of the invention, the outputs of converters **305a-305d** are series connected into a single DC output that forms the input to the load or power supplier, in this example, inverter **304**. The inverter **304** converts the series connected DC output of the converters into an AC power supply. The load, in this case inverter **304**, regulates the voltage at the load's input. That is, in this example, an independent control loop **321** holds the input voltage at a set value, say 400 volts. Consequently, the inverter's input current is dictated by the available power, and this is the current that flows through all serially connected DC sources. On the other hand, while the output of the DC-DC converters must be at the inverter's

current input, the current and voltage input to the converter is independently controlled using the MPPT.

In the conventional art, the input voltage to the load was allowed to vary according to the available power. For example, when a lot of sunshine is available in a solar installation, the voltage input to the inverter can vary even up to 1000 volts. Consequently, as sunshine illumination varies, the voltage varies with it, and the electrical components in the inverter (or other power supplier or load) are exposed to varying voltage. This tends to degrade the performance of the components and ultimately causes them to fail. On the other hand, by fixing the voltage or current to the input of the load or power supplier, here the inverter, the electrical components are always exposed to the same voltage or current and therefore would have extended service life. For example, the components of the load (e.g., capacitors, switches and coil of the inverter) may be selected so that at the fixed input voltage or current they operate at, say, 60% of their rating. This would improve the reliability and prolong the service life of the component, which is critical for avoiding loss of service in applications such as solar power systems.

FIGS. **4A** and **4B** illustrate the operation of the system of FIG. **3** under different conditions, according to aspects of the invention. The exemplary configuration **40** is similar to configuration **30** of FIG. **3**. In the example shown, ten DC power sources **401/1** through **401/10** are connected to ten power converters **405/1** through **405/10**, respectively. The modules formed by the DC power sources and their corresponding converters are coupled together in series to form a string **403**. In one aspect of the invention, the series-connected converters **405** are coupled to a DC-to-AC inverter **404**.

The DC power sources may be solar panels and the example is discussed with respect to solar panels as one illustrative case. Each solar panel **401** may have a different power output due to manufacturing tolerances, shading, or other factors. For the purpose of the present example, an ideal case is illustrated in FIG. **4A**, where efficiency of the DC-to-DC conversion is assumed to be 100% and the panels **501** are assumed to be identical. In some aspects of the invention, efficiencies of the converters may be quite high and range at about 95%-99%. So, the assumption of 100% efficiency is not unreasonable for illustration purposes. Moreover, according to embodiments of the subject invention, each of the DC-DC converters are constructed as a power converter, i.e., it transfers to its output the entire power it receives in its input with very low losses.

Power output of each solar panel **401** is maintained at the maximum power point for the panel by a control loop within the corresponding power converter **405**. In the example shown in FIG. **4A**, all of the panels are exposed to full sun illumination and each solar panel **401** provides 200 W of power. Consequently, the MPPT loop will draw current and voltage level that will transfer the entire 200 W from the panel to its associated converter. That is, the current and voltage dictated by the MPPT form the input current I_{in} and input voltage V_{in} to the converter. The output voltage is dictated by the constant voltage set at the inverter **404**, as will be explained below. The output current I_{out} would then be the total power, i.e., 200 W, divided by the output voltage V_{out} .

As noted above, according to a feature of the invention, the input voltage to inverter **404** is controlled by the inverter (in this example, kept constant), by way of control loop **421**. For the purpose of this example, assume the input voltage is kept as 400V (ideal value for inverting to 220VAC). Since we assume that there are ten serially connected power converters, each providing 200 W, we can see that the input current to the inverter **404** is $2000 \text{ W}/400\text{V}=5 \text{ A}$. Thus, the current flowing

through each of the converters **401/1-401/10** must be 5 A. This means that in this idealized example each of the converters provides an output voltage of 200 W/5 A=40V. Now, assume that the MPPT for each panel (assuming perfect matching panels) dictates $V_{MPP}=32V$. This means that the input voltage to the inverter would be 32V, and the input current would be 200 W/32V=6.25 A. We now turn to another example, wherein the system is still maintained at an ideal mode (i.e., perfectly matching DC sources and entire power is transferred to the inverter), but the environmental conditions are not ideal. For example, one DC source is overheating, is malfunctioning, or, as in the example of FIG. 4B, the ninth solar panel **401/9** is shaded and consequently produces only 40 W of power. Since we keep all other conditions as in the example of FIG. 4A, the other nine solar panels **401** are unshaded and still produce 200 W of power. The power converter **405/9** includes MPPT to maintain the solar panel **501/9** operating at the maximum power point, which is now lowered due to the shading. The total power available from the string is now $9 \times 200 \text{ W} + 40 \text{ W} = 1840 \text{ W}$. Since the input to the inverter is still maintained at 400V, the input current to the inverter will now be $1840 \text{ W} / 40V = 4.6 \text{ A}$. This means that the output of all of the power converters **405/1-405/10** in the string must be at 4.6 A. Therefore, for the nine unshaded panels, the converters will output $200 \text{ W} / 4.6 \text{ A} = 43.5V$. On the other hand, the converter **405/9** attached to the shaded panel **401/9** will output $40 \text{ W} / 4.6 \text{ A} = 8.7V$. Checking the math, the input to the inverter can be obtained by adding nine converters providing 43.5V and one converter providing 8.7V, i.e., $(9 \times 43.5V) + 8.7V = 400V$.

The output of the nine non-shaded panels would still be controlled by the MPPT as in FIG. 4A, thereby standing at 32V and 6.25 A. On the other hand, since the ninth panel **401/9** is shaded, let's assume its MPPT dropped to 28V. Consequently, the output current of the ninth panel is $40 \text{ W} / 28V = 1.43 \text{ A}$. As can be seen by this example, all of the panels are operated at their maximum power point, regardless of operating conditions. As shown by the example of FIG. 4B, even if the output of one DC source drops dramatically, the system still maintains relatively high power output by fixing the voltage input to the inverter, and controlling the input to the converters independently so as to draw power from the DC source at the MPP.

As can be appreciated, the benefit of the topology illustrated in FIGS. 4A and 4B are numerous. For example, the output characteristics of the serially connected DC sources, such as solar panels, need not match. Consequently, the serial string may utilize panels from different manufacturers or panels installed on different parts of the roofs (i.e., at different spatial orientation). Moreover, if several strings are connected in parallel, it is not necessary that the strings match; rather each string may have different panels or different number of panels. This topology also enhances reliability by alleviating the hot spot problem. That is, as shown in FIG. 4A the output of the shaded panel **401/9** is 1.43 A, while the current at the output of the unshaded panels is 6.25 A. This discrepancy in current when the components are series connected causes a large current being forced through the shaded panel that may cause overheating and malfunction at this component. However, by the inventive topology wherein the input voltage is set independently, and the power draw from each panel to its converter is set independently according to the panels MPP at each point in time, the current at each panel is independent on the current draw from the serially connected converters.

It is easily realized that since the power is optimized independently for each panel, panels could be installed in differ-

ent facets and directions in BIPV installations. Thus, the problem of low power utilization in building-integrated installations is solved, and more installations may now be profitable.

The described system could also easily solve the problem of energy harvesting in low light conditions. Even small amounts of light are enough to make the converters **405** operational, and they then start transferring power to the inverter. If small amounts of power are available, there will be a low current flow—but the voltage will be high enough for the inverter to function, and the power will indeed be harvested.

According to aspects of the invention, the inverter **404** includes a control loop **421** to maintain an optimal voltage at the input of inverter **404**. In the example of FIG. 4B, the input voltage to inverter **404** is maintained at 400V by the control loop **421**. The converters **405** are transferring substantially all of the available power from the solar panels to the input of the inverter **404**. As a result, the input current to the inverter **404** is dependent only on the power provided by the solar panels and the regulated set, i.e., constant, voltage at the inverter input.

The conventional inverter **104**, shown in FIG. 1 and FIG. 3, is required to have a very wide input voltage to accommodate for changing conditions, for example a change in luminance, temperature and aging of the solar array. This is in contrast to the inverter **404** that is designed according to aspects of the present invention. The inverter **404** does not require a wide input voltage and is therefore simpler to design and more reliable. This higher reliability is achieved, among other factors, by the fact that there are no voltage spikes at the input to the inverter and thus the components of the inverter experience lower electrical stress and may last longer.

When the inverter **404** is a part of the circuit, the power from the panels is transferred to a load that may be connected to the inverter. To enable the inverter **404** to work at its optimal input voltage, any excess power produced by the solar array, and not used by the load, is dissipated. Excess power may be handled by selling the excess power to the utility company if such an option is available. For off-grid solar arrays, the excess power may be stored in batteries. Yet another option is to connect a number of adjacent houses together to form a micro-grid and to allow load-balancing of power between the houses. If the excess power available from the solar array is not stored or sold, then another mechanism may be provided to dissipate excess power.

The features and benefits explained with respect to FIGS. 4A and 4B stem, at least partially, from having the inverter dictate the voltage provided at its input. Conversely, a design can be implemented wherein the inverter dictates the current at its input. Such an arrangement is illustrated in FIG. 4C. FIG. 4C illustrates an embodiment of the invention wherein the inverter controls the input current. Power output of each solar panel **401** is maintained at the maximum power point for the panel by a control loop within the corresponding power converter **405**. In the example shown in FIG. 4C, all of the panels are exposed to full sun illumination and each solar panel **401** provides 200 W of power. Consequently, the MPPT loop will draw current and voltage level that will transfer the entire 200 W from the panel to its associated converter. That is, the current and voltage dictated by the MPPT form the input current I_{in} and input voltage V_{in} to the converter. The output voltage is dictated by the constant current set at the inverter **404**, as will be explained below. The output voltage V_{out} would then be the total power, i.e., 200 W, divided by the output current I_{out} .

As noted above, according to a feature of the invention, the input current to inverter **404** is dictated by the inverter by way of control loop **421**. For the purpose of this example, assume the input current is kept as 5 A. Since we assume that there are ten serially connected power converters, each providing 200 W, we can see that the input voltage to the inverter **404** is $2000 \text{ W}/5 \text{ A}=400\text{V}$. Thus, the current flowing through each of the converters **401/1-401/10** must be 5 A. This means that in this idealized example each of the converters provides an output voltage of $200 \text{ W}/5 \text{ A}=40\text{V}$. Now, assume that the MPPT for each panel (assuming perfect matching panels) dictates $V_{MPPT}=32\text{V}$. This means that the input voltage to the inverter would be 32V, and the input current would be $200 \text{ W}/32\text{V}=6.25 \text{ A}$.

Consequently, similar advantages have been achieved by having the inverter control the current, rather than the voltage. However, unlike the conventional art, changes in the output of the panels will not cause in changes in the current flowing to the inverter, as that is dictated by the inverter itself. Therefore, if the inverter is designed to keep the current or the voltage constant, then regardless of the operation of the panels, the current or voltage to the inverter will remain constant.

FIG. 5 illustrates a distributed power harvesting system, according to other aspects of the invention, using DC power sources. FIG. 5 illustrates multiple strings **503** coupled together in parallel. Each of the strings is a series connection of multiple modules and each of the modules includes a DC power source **501** that is coupled to a converter **505**. The DC power source may be a solar panel. The output of the parallel connection of the strings **503** is connected, again in parallel, to a shunt regulator **506** and a load controller **504**. The load controller **504** may be an inverter as with the embodiments of FIGS. 4A and 4B. Shunt regulators automatically maintain a constant voltage across its terminals. The shunt regulator **506** is configured to dissipate excess power to maintain the input voltage at the input to the inverter **504** at a regulated level and prevent the inverter input voltage from increasing. The current which flows through shunt regulator **506** complements the current drawn by inverter **504** in order to ensure that the input voltage of the inverter is maintained at a constant level, for example at 400V.

By fixing the inverter input voltage, the inverter input current is varied according to the available power draw. This current is divided between the strings **503** of the series connected converters. When each converter includes a controller loop maintaining the converter input voltage at the maximum power point of the associated DC power source, the output power of the converter is determined. The converter power and the converter output current together determine the converter output voltage. The converter output voltage is used by a power conversion circuit in the converter for stepping up or stepping down the converter input voltage to obtain the converter output voltage from the input voltage as determined by the MPPT.

FIG. 6 illustrates an exemplary DC-to-DC converter **605** according to aspects of the invention. DC-to-DC converters are conventionally used to either step down or step up a varied or constant DC voltage input to a higher or a lower constant voltage output, depending on the requirements of the circuit. However, in the embodiment of FIG. 6 the DC-DC converter is used as a power converter, i.e., transferring the input power to output power, the input voltage varying according to the MPPT, while the output current being dictated by the constant input voltage to the inverter. That is, the input voltage and current may vary at any time and the output voltage and current may vary at any time, depending on the operating condition of the DC power sources.

The converter **605** is connected to a corresponding DC power source **601** at input terminals **614** and **616**. The converted power of the DC power source **601** is output to the circuit through output terminals **610**, **612**. Between the input terminals **614**, **616** and the output terminals **610**, **612**, the remainder of the converter circuit is located that includes input and output capacitors **620**, **640**, back flow prevention diodes **622**, **642** and a power conversion circuit including a controller **606** and an inductor **608**.

The inputs **616** and **614** are separated by a capacitor **620** which acts as an open to a DC voltage. The outputs **610** and **612** are also separated by a capacitor **640** that also acts an open to DC output voltage. These capacitors are DC-blocking or AC-coupling capacitors that short when faced with alternating current of a frequency for which they are selected. Capacitor **640** coupled between the outputs **610**, **612** and also operates as a part of the power conversion circuit discussed below.

Diode **642** is coupled between the outputs **610** and **612** with a polarity such that current may not backflow into the converter **605** from the positive lead of the output **612**. Diode **622** is coupled between the positive output lead **612** through inductor **608** which acts a short for DC current and the negative input lead **614** with such polarity to prevent a current from the output **612** to backflow into the solar panel **601**.

The DC power sources **601** may be solar panels. A potential difference exists between the wires **614** and **616** due to the electron-hole pairs produced in the solar cells of panel **601**. The converter **605** maintains maximum power output by extracting current from the solar panel **601** at its peak power point by continuously monitoring the current and voltage provided by the panel and using a maximum power point tracking algorithm. The controller **606** includes an MPPT circuit or algorithm for performing the peak power tracking. Peak power tracking and pulse width modulation, PWM, are performed together to achieve the desired input voltage and current. The MPPT in the controller **606** may be any conventional MPPT, such as, e.g., perturb and observe (P&O), incremental conductance, etc. However, notably the MPPT is performed on the panel directly, i.e., at the input to the converter, rather than at the output of the converter. The generated power is then transferred to the output terminals **610** and **612**. The outputs of multiple converters **605** may be connected in series, such that the positive lead **612** of one converter **605** is connected to the negative lead **610** of the next converter **605**.

In FIG. 6, the converter **605** is shown as a buck plus boost converter. The term "buck plus boost" as used herein is a buck converter directly followed by a boost converter as shown in FIG. 6, which may also appear in the literature as "cascaded buck-boost converter". If the voltage is to be lowered, the boost portion is substantially shorted. If the voltage is to be raised, the buck portion is substantially shorted. The term "buck plus boost" differs from buck/boost topology which is a classic topology that may be used when voltage is to be raised or lowered. The efficiency of "buck/boost" topology is inherently lower than a buck or a boost. Additionally, for given requirements, a buck-boost converter will need bigger passive components than a buck plus boost converter in order to function. Therefore, the buck plus boost topology of FIG. 6 has a higher efficiency than the buck/boost topology. However, the circuit of FIG. 6 continuously decides whether it is bucking or boosting. In some situations when the desired output voltage is similar to the input voltage, then both the buck and boost portions may be operational.

The controller **606** may include a pulse width modulator, PWM, or a digital pulse width modulator, DPWM, to be used with the buck and boost converter circuits. The controller **606**

controls both the buck converter and the boost converter and determines whether a buck or a boost operation is to be performed. In some circumstances both the buck and boost portions may operate together. That is, as explained with respect to the embodiments of FIGS. 4A and 4B, the input voltage and current are selected independently of the selection of output current and voltage. Moreover, the selection of either input or output values may change at any given moment depending on the operation of the DC power sources. Therefore, in the embodiment of FIG. 6 the converter is constructed so that at any given time a selected value of input voltage and current may be up converted or down converted depending on the output requirement.

In one implementation, an integrated circuit (IC) 604 may be used that incorporates some of the functionality of converter 605. IC 604 is optionally a single ASIC able to withstand harsh temperature extremes present in outdoor solar installations. ASIC 604 may be designed for a high mean time between failures (MTBF) of more than 25 years. However, a discrete solution using multiple integrated circuits may also be used in a similar manner. In the exemplary embodiment shown in FIG. 6, the buck plus boost portion of the converter 605 is implemented as the IC 604. Practical considerations may lead to other segmentations of the system. For example, in one aspect of the invention, the IC 604 may include two ICs, one analog IC which handles the high currents and voltages in the system, and one simple low-voltage digital IC which includes the control logic. The analog IC may be implemented using power FETs which may alternatively be implemented in discrete components, FET drivers, A/Ds, and the like. The digital IC may form the controller 606.

In the exemplary circuit shown, the buck converter includes the input capacitor 620, transistors 628 and 630 a diode 622 positioned in parallel to transistor 628, and an inductor 608. The transistors 628, 630 each have a parasitic body diode 624, 626. In the exemplary circuit shown, the boost converter includes the inductor 608, which is shared with the buck converter, transistors 648 and 650 a diode 642 positioned in parallel to transistor 650, and the output capacitor 640. The transistors 648, 650 each have a parasitic body diode 644, 646.

As shown in FIG. 1, adding electronic elements in the series arrangement may reduce the reliability of the system, because if one electrical component breaks it may affect the entire system. Specifically, if a failure in one of the serially connected elements causes an open circuit in the failed element, current ceases to flow through the entire series, thereby causing the entire system to stop function. Aspects of the present invention provide a converter circuit where electrical elements of the circuit have one or more bypass routes associated with them that carry the current in case of the electrical element fails. For example, each switching transistor of either the buck or the boost portion of the converter has its own bypass. Upon failure of any of the switching transistors, that element of the circuit is bypassed. Also, upon inductor failure, the current bypasses the failed inductor through the parasitic diodes of the transistor used in the boost converter.

FIG. 7 illustrates a power converter, according to aspects of the invention. FIG. 7 highlights, among others, a monitoring and control functionality of a DC-to-DC converter 705, according to embodiments of the present invention. A DC voltage source 701 is also shown in the figure. Portions of a simplified buck and boost converter circuit are shown for the converter 705. The portions shown include the switching transistors 728, 730, 748 and 750 and the common inductor 708. Each of the switching transistors is controlled by a power conversion controller 706.

The power conversion controller 706 includes the pulse-width modulation (PWM) circuit 733, and a digital control machine 730 including a protection portion 737. The power conversion controller 706 is coupled to microcontroller 790, which includes an MPPT module 719, and may also optionally include a communication module 709, a monitoring and logging module 711, and a protection module 735.

A current sensor 703 may be coupled between the DC power source 701 and the converter 705, and output of the current sensor 703 may be provided to the digital control machine 730 through an associated analog to digital converter 723. A voltage sensor 704 may be coupled between the DC power source 701 and the converter 705 and output of the voltage sensor 704 may be provided to the digital control machine 730 through an associated analog to digital converter 724. The current sensor 703 and the voltage sensor 704 are used to monitor current and voltage output from the DC power source, e.g., the solar panel 701. The measured current and voltage are provided to the digital control machine 730 and are used to maintain the converter input power at the maximum power point.

The PWM circuit 733 controls the switching transistors of the buck and boost portions of the converter circuit. The PWM circuit may be a digital pulse-width modulation (DPWM) circuit. Outputs of the converter 705 taken at the inductor 708 and at the switching transistor 750 are provided to the digital control machine 730 through analog to digital converters 741, 742, so as to control the PWM circuit 733.

A random access memory (RAM) module 715 and a non-volatile random access memory (NVRAM) module 713 may be located outside the microcontroller 790 but coupled to the microcontroller 790. A temperature sensor 779 and one or more external sensor interfaces 707 may be coupled to the microcontroller 790. The temperature sensor 779 may be used to measure the temperature of the DC power source 701. A physical interface 717 may be coupled to the microcontroller 790 and used to convert data from the microcontroller into a standard communication protocol and physical layer. An internal power supply unit 739 may be included in the converter 705.

In various aspects of the invention, the current sensor 703 may be implemented by various techniques used to measure current. In one aspect of the invention, the current measurement module 703 is implemented using a very low value resistor. The voltage across the resistor will be proportional to the current flowing through the resistor. In another aspect of the invention, the current measurement module 703 is implemented using current probes which use the Hall Effect to measure the current through a conductor without adding a series resistor. After translating the current to voltage, the data may be passed through a low pass filter and then digitized. The analog to digital converter associated with the current sensor 703 is shown as the A/D converter 723 in FIG. 7. Aliasing effect in the resulting digital data may be avoided by selecting an appropriate resolution and sample rate for the analog to digital converter. If the current sensing technique does not require a series connection, then the current sensor 703 may be connected to the DC power source 701 in parallel.

In one aspect of the invention, the voltage sensor 704 uses simple parallel voltage measurement techniques in order to measure the voltage output of the solar panel. The analog voltage is passed through a low pass filter in order to minimize aliasing. The data is then digitized using an analog to digital converter. The analog to digital converter associated with the voltage sensor 704 are shown as the A/D converter 724 in FIG. 7. The A/D converter 724 has sufficient resolution to

generate an adequately sampled digital signal from the analog voltage measured at the DC power source **701** that may be a solar panel.

The current and voltage data collected for tracking the maximum power point at the converter input may be used for monitoring purposes also. An analog to digital converter with sufficient resolution may correctly evaluate the panel voltage and current. However, to evaluate the state of the panel, even low sample rates may be sufficient. A low-pass filter makes it possible for low sample rates to be sufficient for evaluating the state of the panel. The current and voltage data may be provided to the monitoring and logging module **711** for analysis.

The temperature sensor **779** enables the system to use temperature data in the analysis process. The temperature is indicative of some types of failures and problems. Furthermore, in the case that the power source is a solar panel, the panel temperature is a factor in power output production.

The one or more optional external sensor interfaces **707** enable connecting various external sensors to the converter **705**. External sensors are optionally used to enhance analysis of the state of the solar panel **701**, or a string or an array formed by connecting the solar panels **701**. Examples of external sensors include ambient temperature sensors, solar radiance sensors, and sensors from neighboring panels. External sensors may be integrated into the converter **705** instead of being attached externally.

In one aspect of the invention, the information acquired from the current and voltage sensors **703**, **704** and the optional temperature and external sensors **705**, **707** may be transmitted to a central analysis station for monitoring, control, and analysis using the communications interface **709**. The central analysis station is not shown in the figure. The communication interface **709** connects a microcontroller **790** to a communication bus. The communication bus can be implemented in several ways. In one aspect of the invention, the communication bus is implemented using an off-the-shelf communication bus such as Ethernet or RS422. Other methods such as wireless communications or power line communications, which could be implemented on the power line connecting the panels, may also be used. If bidirectional communication is used, the central analysis station may request the data collected by the microcontroller **790**. Alternatively or in addition, the information acquired from sensors **703**, **704**, **705**, **707** is logged locally using the monitoring and logging module **711** in local memory such as the RAM **715** or the NVRAM **713**.

Analysis of the information from sensors **703**, **704**, **705**, **707** enables detection and location of many types of failures associated with power loss in solar arrays. Smart analysis can also be used to suggest corrective measures such as cleaning or replacing a specific portion of the solar array. Analysis of sensor information can also detect power losses caused by environmental conditions or installation mistakes and prevent costly and difficult solar array testing.

Consequently, in one aspect of the invention, the microcontroller **790** simultaneously maintains the maximum power point of input power to the converter **705** from the attached DC power source or solar panel **701** based on the MPPT algorithm in the MPPT module **719** and manages the process of gathering the information from sensors **703**, **704**, **705**, **707**. The collected information may be stored in the local memory **713**, **715** and transmitted to an external central analysis station. In one aspect of the invention, the microcontroller **790** uses previously defined parameters stored in the NVRAM **713** in order to operate. The information stored in the NVRAM **713** may include information about the converter

705 such as serial number, the type of communication bus used, the status update rate and the ID of the central analysis station. This information may be added to the parameters collected by the sensors before transmission.

The converters **705** may be installed during the installation of the solar array or retrofitted to existing installations. In both cases, the converters **705** may be connected to a panel junction connection box or to cables connecting the panels **701**. Each converter **705** may be provided with the connectors and cabling to enable easy installation and connection to solar panels **701** and panel cables.

In one aspect of the invention, the physical interface **717** is used to convert to a standard communication protocol and physical layer so that during installation and maintenance, the converter **705** may be connected to one of various data terminals, such as a computer or PDA. Analysis may then be implemented as software which will be run on a standard computer, an embedded platform or a proprietary device.

The installation process of the converters **705** includes connecting each converter **705** to a solar panel **701**. One or more of the sensors **703**, **704**, **705**, **707** may be used to ensure that the solar panel **701** and the converter **705** are properly coupled together. During installation, parameters such as serial number, physical location and the array connection topology may be stored in the NVRAM **713**. These parameters may be used by analysis software to detect future problems in solar panels **701** and arrays.

When the DC power sources **701** are solar panels, one of the problems facing installers of photovoltaic solar panel arrays is safety. The solar panels **701** are connected in series during the day when there is sunlight. Therefore, at the final stages of installation, when several solar panels **701** are connected in series, the voltage across a string of panels may reach dangerous levels. Voltages as high as 600V are common in domestic installations. Thus, the installer faces a danger of electrocution. The converters **705** that are connected to the panels **701** may use built-in functionality to prevent such a danger. For example, the converters **705** may include circuitry or hardware of software safety module that limits the output voltage to a safe level until a predetermined minimum load is detected. Only after detecting this predetermined load, the microcontroller **790** ramps up the output voltage from the converter **705**.

Another method of providing a safety mechanism is to use communications between the converters **705** and the associated inverter for the string or array of panels. This communication, that may be for example a power line communication, may provide a handshake before any significant or potentially dangerous power level is made available. Thus, the converters **705** would wait for an analog or digital release signal from the inverter in the associated array before transferring power to inverter.

The above methodology for monitoring, control and analysis of the DC power sources **701** may be implemented on solar panels or on strings or arrays of solar panels or for other power sources such as batteries and fuel cells.

Use of Battery as DC Power Source/sink

A typical rechargeable battery may be made with serially connected secondary cells and in some cases, several parallel strings of serially connected cells. Serially connected secondary cells are used to build a battery voltage high enough to fit a specific application voltage. A typical generic charging application applied to a rechargeable battery, may include a bulk power source which provides raw DC power to the rechargeable battery and a regulator which regulates current and/or voltage applied to the rechargeable battery. For less-expensive chargers, the regulator is usually a power transistor

or other linear-pass element that dissipates power as heat. The regulator may also be a buck switching supply that includes a standard freewheeling diode for average efficiency or a synchronous rectifier for highest efficiency. The typical generic charging application may further include a current-control loop which limits the maximum current delivered to the battery, and a voltage loop which maintains a constant voltage on the battery. (Note that Li+ cells typically require a high level of precision in the applied charging voltage.) Also the current-voltage (I-V) characteristic may be fully programmable, or may be programmable in current only, with a voltage limit (or vice versa). Cell temperature of the battery may be measured, and charge termination can be based either on the level or the slope of this measurement. Charging time may be measured, usually as a calculation in an intelligence block such as micro-processor with memory for example. The intelligence block provides intelligence for the system and typically implements a state machine. The intelligence block using the state machine knows how and when to terminate a charge. Discharge is done, usually, directly from a cell array, via current sensing (in order to keep track of actual battery charge).

A serial connection of battery cells may pose a challenge in managing the charge and discharge of battery cells. All cells typically must be matched in terms of electrical characteristics and initial charge levels. Cells also need to be matched thermally otherwise the same electrical conditions can have different (and catastrophic) results for different cells. Usually several temperature sensors are used to meet the needed safety requirements but the typical outcome is that the entire battery charge performance is limited by the weakest cell. Adding several parallel strings of cells may be an additional challenge, since impedance of all cells are low, any small impedance difference may result in a large variance in current between strings. The large variance in current between strings may be difficult to manage without some separate circuit hardware per string.

Reference is now made to FIG. 3a which show system 30a according to an embodiment of the present invention. System 30a includes converters 305a-305d with terminals connected in series to form a string 3003, the same as shown in configuration 30 (FIG. 3). The other terminals of converters 305a-305d are connected to re-chargeable cells 6001a-6001d respectively to form a module 320a. Each module 320a includes a control loop 323i that receives a feedback signal, from the connection between a converter 305 and a cell 6001. Loop 323i typically determines the voltage across the connection between converter 305 and cell 6001 and/or the current between converter 305 and cell 6001. String 3003 is connected to a terminal of power controller 3004a. Several strings 3003 may be further connected to the terminal of power controller 3004a by connecting strings 3003 in parallel. The other terminal 330 of power controller 3004 may be connected to a power supply or a load. The power supply may be an AC supply such as a grid voltage or a DC supply. The load may be an AC load or a DC load. System 30a typically operates in two modes. One mode is the discharge of cells 6001 to supply the load or the power supply connected to power controller 3004a. The other mode is to charge cells 6001 via power controller 3004a when controller 3004a is connected to the power supply. During charging of cells 6001, controller 3004a typically operates as a parallel charger. Controller 3004a acts as a voltage source that supplies any amount of power up to the total power available by the power source. The voltage source can be fixed to almost any voltage and can be optimized depending on the amount of modules 320a. Power controller 3004a may be DC to AC inverter or a DC to DC converter the same as a converter 305 for example.

According to a feature of the present invention an independent control loop 321a of controller 3004a typically holds the voltage of string 3003 at a set value.

Reference is now made to FIG. 3b which shows system 30b according to an embodiment of the present invention. System 30a includes converters 305a-305d with terminals connected in series to form a string 3003, the same as show in configuration 30a (shown in FIG. 3a). The other terminals of converters 305a-305d are connected to re-chargeable cells 6001a-6001d respectively to form a module 320a. Each module 320a includes two control loops 323i and 323o. Converter 305 may independently choose which loop 323i or 323o to use for operation of converter 305. Converter 305 may also operate control loops 323i and 323o simultaneously, such that loop 323i determines the voltage and current of battery 6001 and hence the power (P) of battery 6001. Whilst at the same time, loop 323o determines the voltage and current of converter 305 and therefore power in string 3003. The voltages and currents on either side of converter 305 change respectively in order to preserve maximum power through converter 305. Converter 3004a typically may be another DC-DC converter 305 without loops 323i and 323o or may be a DC-AC inverter. Loop 323i provides a feedback signal to converter 305, from the connection between converter 305 and cell 6001. Loop 323i typically determines the voltage across the connection between converter 305 and cell 6001 and/or the direction of current (i.e. charging or discharging) between converter 305 and cell 6001. Loop 323o provides a feedback signal to converter 305 from string 3003. Loop 323o typically determines the voltage contribution of converter 305 to string 3003 and/or the direction of current to converter 305.

String 3003 is connected to converter 3004a. Several strings 3003 may be further connected to converter 3004a by connecting strings 3003 in parallel. The other side 330 of converter 3004 may be connected to a power supply or a load. The power supply may be an AC supply such as a grid voltage or a DC supply. The load may be an AC load or a DC load. System 30b typically operates in two modes. One mode is the discharge of cells 6001 to supply the load or the power supply connected to converter 3004a. The other mode is to charge cells 6001 via converter 3004a connected to the power supply. During charging of cells 6001, converter 3004a typically operates as a simplified parallel charger. Converter 3004a acts as a voltage source that supplies any amount of power up to the total power available by the power source. The voltage source can be fixed to almost any voltage and can be optimized depending on the number of modules 320a.

Reference is now made to FIG. 3c which show system 30c according to an embodiment of the present invention. System 30c includes converters 305a-305d with terminals connected in series to form a string 3003, the same as show in configuration 30a (shown in FIG. 3a). The other terminals of converters 305a-305d are connected to re-chargeable cells 6001a-6001d respectively to form a module 320a. Each module 320a includes battery 6001, converter 305, and control loop 323i. Serial string of modules 320a is connected in parallel with a second serial string 303 of modules 320 including photovoltaic panel 301, and converter 305 each with control loop 323i. The two serial strings are connected to power converter 3004a which may be a grid connected DC-AC inverter or DC-DC converter on connection 330 for instance. Power converter 3004a is shown with a control loop 321a which sets the voltage or current in the parallel-connected serial strings at a previously determined value generally dependent on the direction of current flow, i.e. charging or discharging. System 30c may be used for grid-connected or off grid applications. In particular, photovoltaic module

string **303** may be used to charge batteries of battery string **3003**. The energy stored in battery string **3003** may be sold to the grid at a later time for instance when the electricity price tariffs are higher.

During charging a converter **305** acts as an optimized charger for a battery **6001**. Charging a battery **6001** is preferably performed by controlling the current (I)/voltage (V) characteristics of a charge profile for a converter **305**, to feed into a battery **6001** the most favorable charge power needed at any given time. Converter **305** may also act as a current source, perform voltage regulation or trickle charge depending on need. One side of each converter **305** may draw a different power from controller **3004a**, depending on power needed by a battery **6001** connected to the other side of converter **305**. By sharing the same battery string **3003** current, the voltage of each converter **305** in battery string **3003** will typically be different for each converter **305**. The total voltage provided by string **3003** will typically be the voltage set by controller **3004a**. If a battery is fully charged, converter **305** will enter a bypass mode in which it is not taking power from controller **3004a**. Controller **3004a** may also turn ON or OFF any number of converters **305** in case controller **3004a** does not have enough power to charge all batteries **6001**. In an optimal way, controller **3004a** can shut OFF some of converters **305** leaving only some of batteries **6001** to be charged. Once batteries **6001** are fully charged converters **305** will shut OFF and other batteries **6001** can be charged. By charging some batteries **6001** and not other batteries **6001** means batteries **6001** are always charged in the most efficient way independent of the amount of power available for charging. Controller **3004a** communicates with converters **305** via power line communication so additional wires are not needed for charge control of batteries **6001**.

Discharge of batteries **6001** is very similar to harvesting power from different rated photovoltaic modules (PV) modules **301** and/or PV strings **303**. Controller **3004a** regulates the string **3003** voltage to a fixed voltage. Each converter **305** will discharge the power in battery **6001**. Controller **3004a** may increase or decrease the total amount of power drawn via communication with converters **305** so that the total power supplied is equal to the load needed. Each converter **305** will supply the energy available from its battery **6001**. By sharing the same string **3003** current, the voltage of each converter **305** on the side connected to controller **3004a** will be different for each converter **305**. The total voltage across string **3004a** is typically set by controller **3004a**.

Reference is now made to FIG. **6a** which shows a slightly modified DC-DC converter **305** based on the DC-DC converter **605** shown in FIG. **6**, according to an embodiment of the present invention. Converter **305** additionally includes high frequency transducer **62** and low frequency transducer **63** placed in negative power line **614**. Transducers **62** and **63** typically include analogue to digital converters and means for power line communication or wireless communication. Transducer **62** (operatively attached to controller **606**) typically senses current in the higher frequency portion of converter **305** where switches **628**, **626**, **648**, and **646** are typically switching at a high frequency. The sensed current of transducer **62** is typically conveyed by transducer to controller **606** by wireless communication or power line communication. Transducer **63** (operatively attached to controller **606**) typically includes monitoring of current, temperature of battery **6001**. The sensed current, temperature of battery **6001** are also conveyed to controller **606** using wireless communication or power line communication. Controller **606** typically includes a microprocessor with memory. Converter **305** connects to battery **6001** with positive node **616** and negative

node **614**. The other end of converter **305** has lines **614** and **612**. Multiple lines **614** and **612** of multiple converters **305** are typically joined to together in series, by connecting a line **614** of one converter with a line **612** of another converter **305** to form a battery string **3003**. A typical bypass route between power lines **612** and **610** of a converter **305** may be to have switches **650** and **644** ON and switches **630** and **628** OFF. Converter **305** is a Buck-Boost topology power converter that has the ability to control its transferred I-V curve. The topology of the converter **305** is basically symmetrical thus enabling converter **305** to convert power in either direction.

The definite articles “a”, “an” is used herein, such as “a power converter”, “a control loop” have the meaning of “one or more” that is “one or more power converters” or “one or more control loops”.

Although selected embodiments of the present invention have been shown and described, it is to be understood the present invention is not limited to the described embodiments. Instead, it is to be appreciated that changes may be made to these embodiments without departing from the principles and spirit of the invention, the scope of which is defined by the claims and the equivalents thereof.

We claim:

1. A distributed power system comprising:
 - a plurality of DC power sources, each DC power source with positive and negative poles;
 - a plurality of power converters coupled respectively to the DC power sources, each power converter including a first terminal, a second terminal, a third terminal and a fourth terminal, wherein said first terminal is adapted for coupling to said positive pole and said second terminal is adapted for coupling to said negative pole;
 - wherein each said power converter includes:
 - (i) a control loop adapted for setting the voltage between or current through said first and second terminals, and
 - (ii) a power conversion portion adapted to perform at least one of: converting power from said first and second terminals to said third and fourth terminals to discharge said power source connected thereto, or converting power from said third and fourth terminals to said first and second terminals to charge said power source connected thereto;
 - wherein each of said power converters is adapted for serial connection to at least one other power converter by connecting respectively said third and fourth terminals, thereby forming a serial string; and
 - a power controller adapted for coupling to said serial string, the power controller including a control part adapted to maintain current through or voltage across said serial string at a predetermined value.
2. The distributed power system of claim 1, wherein the control part maintains voltage across said serial string at a predetermined value.
3. The distributed power system of claim 1, wherein the control part maintains current through said serial string at a predetermined value.
4. The distributed power system of claim 1, wherein the power controller includes a bi-directional DC/AC inverter.
5. The distributed power system of claim 1, wherein the power controller includes a bi-directional DC/DC converter.
6. The distributed power system of claim 1, wherein said power converters have a function selected from the group consisting of: current source, voltage regulation or trickle charge.
7. The distributed power system according to claim 1, wherein the DC power sources comprise DC batteries.

21

8. The distributed power system according to claim 7, further comprising:

- a plurality of photovoltaic panels;
- a plurality of DC-to-DC converters, each of the DC-to-DC converters including:
 - one or more input terminals coupled to one or more of the photovoltaic panels;
 - one or more output terminals coupled in series to one or more of the other DC-to-DC converters, thereby forming a second serial string;
 - a control loop adapted to set the voltage and current at the input terminals of the DC-to-DC converter according to predetermined criteria; and,
 - a power conversion portion adapted to convert the power received at the input terminals to an output power at the output terminals;

wherein said serial string and said second serial string are connectible in parallel to form parallel-connected strings.

9. The distributed power system according to claim 8, wherein the power controller is further adapted for coupling in parallel to said parallel-connected strings, wherein the control part of the power controller is further adapted to maintain current through or voltage across said parallel connected strings at a predetermined value.

10. The distributed power system according to claim 8, wherein said power controller is selectably either off-grid or connected to grid.

11. The distributed power system according to claim 8, wherein said photovoltaic panels provide electrical power for charging said DC power sources.

12. The distributed power system according to claim 1, wherein the DC power sources comprise solar panels.

13. A distributed power system comprising:
- a plurality of DC power sources, each DC power source with positive and negative poles;
 - a plurality of power converters coupled respectively to the DC power sources, each power converter including a first terminal, a second terminal, a third terminal and a fourth terminal, wherein said first terminal is adapted for coupling to said positive pole and said second terminal is adapted for coupling to said negative pole;

wherein each said power converter includes:

- (i) a first control loop configured to set either current through or voltage between said first and second terminals,
- (ii) a second control loop configured set either current through or voltage between said third and fourth terminals; and
- (iii) a power conversion portion adapted to perform at least one of: converting power from said first and second terminals to said third and fourth terminals to discharge said power source connected thereto, or converting power from said third and fourth terminals to said first and second terminals to charge said power source connected thereto;

wherein each of said power converters is adapted for serial connection to at least one other power converter by connecting respectively said third and fourth terminals, thereby forming a serial string.

22

14. The distributed power system according to claim 13, wherein the DC power sources comprise DC batteries.

15. The distributed power system according to claim 14, further comprising:

- a plurality of photovoltaic panels;
- a plurality of DC-to-DC converters, each of the DC-to-DC converters including:
 - one or more input terminals coupled to one or more of the DC photovoltaic panels;
 - one or more output terminals coupled in series to one or more of the other DC-to-DC converters, thereby forming a second serial string;
 - a control loop adapted to set the voltage and current at the input terminals of the DC-to-DC converter according to predetermined criteria; and,
 - a power conversion portion adapted to convert the power received at the input terminals to an output power at the output terminals;

wherein said serial string and said second serial string are connectible in parallel.

16. The distributed power system according to claim 15, further comprising a power controller, wherein said power controller is selectably either off-grid or connected to grid.

17. The distributed power system according to claim 15, wherein said photovoltaic panels provide electrical power for charging said power sources.

18. The distributed power system according to claim 15, further comprising a communications interface between said power converters and a power controller for controlling charging and discharging of said power sources.

19. The distributed power system according to claim 13, wherein the DC power sources comprise solar panels.

20. A method, comprising:

- coupling a plurality of DC power sources to a plurality of power converters, wherein each said DC power source includes a positive and a negative pole, wherein each said power converter includes a first terminal, a second terminal, a third terminal and a fourth terminal, wherein said first terminal is adapted for coupling to said positive pole and said second terminal is adapted for coupling to said negative pole, and wherein each said power converter further includes:

- (i) a control loop adapted for setting the voltage between or current through said first and second terminals, and
- (ii) a power conversion portion adapted to perform at least one of: converting power from said first and second terminals to said third and fourth terminals to discharge said power source connected thereto, or converting power from said third and fourth terminals to said first and second terminals to charge said power source connected thereto;

connecting in serial each of said power converters to at least one other power converter by connecting respectively said third and fourth terminals, thereby forming a serial string; and

coupling a power controller to said serial string, the power controller including a control part adapted to maintain current through or voltage across said serial string at a predetermined value.

* * * * *

UNITED STATES PATENT AND TRADEMARK OFFICE
CERTIFICATE OF CORRECTION

PATENT NO. : 8,618,692 B2
APPLICATION NO. : 12/911153
DATED : December 31, 2013
INVENTOR(S) : Meir Adest et al.

Page 1 of 1

It is certified that error appears in the above-identified patent and that said Letters Patent is hereby corrected as shown below:

On the Title Page:

The first or sole Notice should read --

Subject to any disclaimer, the term of this patent is extended or adjusted under 35 U.S.C. 154(b)
by 498 days.

Signed and Sealed this
Eleventh Day of August, 2015



Michelle K. Lee
Director of the United States Patent and Trademark Office