



US008588535B2

(12) **United States Patent**
Segall

(10) **Patent No.:** **US 8,588,535 B2**
(45) **Date of Patent:** **Nov. 19, 2013**

(54) **METHODS AND SYSTEMS FOR ESTIMATION OF COMPRESSION NOISE**

(75) Inventor: **Christopher A. Segall**, Camas, WA (US)

(73) Assignee: **Sharp Laboratories of America, Inc.**, Camas, WA (US)

(*) Notice: Subject to any disclaimer, the term of this patent is extended or adjusted under 35 U.S.C. 154(b) by 607 days.

(21) Appl. No.: **12/882,763**

(22) Filed: **Sep. 15, 2010**

(65) **Prior Publication Data**
US 2012/0063694 A1 Mar. 15, 2012

(51) **Int. Cl.**
G06K 9/36 (2006.01)
G06K 9/46 (2006.01)

(52) **U.S. Cl.**
USPC **382/232**

(58) **Field of Classification Search**
USPC 382/232
See application file for complete search history.

(56) **References Cited**
U.S. PATENT DOCUMENTS

4,463,381 A	7/1984	Powell et al.
5,021,891 A	6/1991	Lee
5,081,692 A	1/1992	Kwon et al.
5,224,062 A	6/1993	McMillan, Jr. et al.
5,282,030 A	1/1994	Nishimura et al.
5,802,481 A	9/1998	Prieto
5,822,011 A	10/1998	Rumreich
5,825,936 A	10/1998	Clarke et al.
5,847,714 A	12/1998	Naqvi et al.
5,974,181 A	10/1999	Prieto
6,055,340 A	4/2000	Nagao
6,289,133 B1	9/2001	Oshino

6,342,925 B1	1/2002	Akhavan et al.
6,343,158 B1	1/2002	Shiohara
6,466,624 B1	10/2002	Fogg
6,636,645 B1	10/2003	Yu et al.
6,810,086 B1	10/2004	Puri et al.
6,944,321 B2	9/2005	Hamid

(Continued)

FOREIGN PATENT DOCUMENTS

EP	2216988 A1	8/2010
JP	10/243238 A	9/1998

(Continued)

OTHER PUBLICATIONS

USPTO Notice of Allowance—U.S. Appl. No. 12/892,816—Mailing Date Dec. 29, 2011.

(Continued)

Primary Examiner — Bernard Krasnic

(74) *Attorney, Agent, or Firm* — Kristine Elizabeth Matthews; David C. Ripma

(57) **ABSTRACT**

Systems and methods for determining the compression noise present in an image or frame in a video sequence are provided. Horizontal and vertical pixel value differences are computed. A plurality of horizontal standard deviation values associated with a plurality of horizontal offsets are computed, and a plurality of vertical standard deviation values associated with a plurality of vertical offsets are computed. Two horizontal statistics are computed using the plurality of horizontal standard deviation values, and two vertical statistics are computed using the plurality of vertical standard deviation values. The two horizontal statistics are combined to form an estimate of horizontal compression noise, and the two vertical statistics are combined to form an estimate of vertical compression noise. The estimate of horizontal compression noise is combined with the estimate of vertical compression noise to form a compression noise estimate.

25 Claims, 17 Drawing Sheets

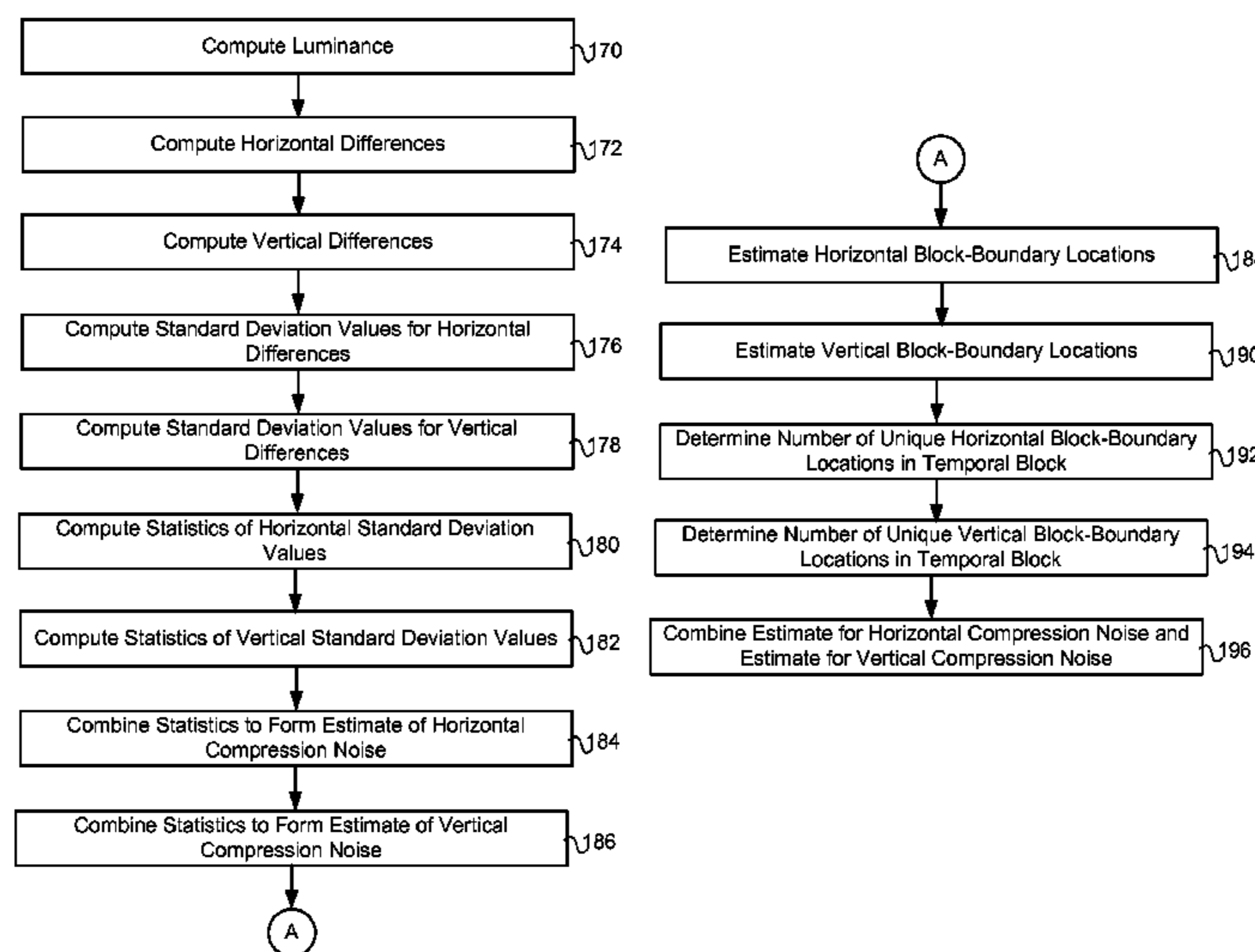

(56)

References Cited

U.S. PATENT DOCUMENTS

6,957,147	B2	10/2005	Baliguet et al.
6,990,252	B2	1/2006	Shekter
7,046,307	B1	5/2006	Hui
7,119,852	B1	10/2006	Vandeginste
7,139,035	B2	11/2006	Kempf
7,206,459	B2	4/2007	Berkner et al.
7,266,246	B2	9/2007	Shaked et al.
7,454,053	B2	11/2008	Bryll et al.
7,570,831	B2	8/2009	Shaked et al.
7,599,570	B2	10/2009	Berkner
7,899,263	B2	3/2011	Li et al.
8,144,253	B2	3/2012	Su et al.
2001/0038716	A1	11/2001	Tsuchiya et al.
2002/0034337	A1	3/2002	Shekter
2003/0086623	A1	5/2003	Berkner et al.
2003/0223597	A1	12/2003	Puria et al.
2004/0013310	A1	1/2004	Suino et al.
2004/0037466	A1	2/2004	Gewaltig et al.
2004/0169873	A1	9/2004	Nagarajan
2005/0244061	A1	11/2005	Shaked et al.
2005/0276515	A1	12/2005	Shekter
2006/0093205	A1	5/2006	Bryll et al.
2006/0103892	A1	5/2006	Schulze et al.
2006/0140268	A1	6/2006	Ha et al.
2006/0171466	A1*	8/2006	Schoner et al. 375/240.24
2006/0171473	A1	8/2006	Schoner
2007/0160304	A1	7/2007	Berkner et al.
2007/0201759	A1	8/2007	Lee et al.
2007/0223835	A1	9/2007	Yamada et al.
2007/0237241	A1	10/2007	Ha et al.
2007/0242896	A1	10/2007	Okumichi et al.
2007/0280552	A1	12/2007	Lee et al.
2008/0013847	A1	1/2008	Li
2008/0037044	A1	2/2008	Tse et al.
2008/0095466	A1	4/2008	Kinrot et al.
2008/0174699	A1	7/2008	Suzuki et al.
2008/0247664	A1	10/2008	Lee et al.
2009/0079855	A1	3/2009	Ito et al.
2009/0214133	A1	8/2009	Aoyama
2009/0245679	A1	10/2009	Ohwaki et al.
2009/0324066	A1	12/2009	Saito et al.
2010/0074548	A1	3/2010	Pan et al.
2010/0202262	A1	8/2010	Adams et al.
2010/0220222	A1	9/2010	Naito
2012/0062797	A1	3/2012	Segall
2012/0281758	A1	11/2012	Orlick et al.

FOREIGN PATENT DOCUMENTS

JP	2001-094832	A	4/2001
JP	2002/033941	A	1/2002
JP	2002/077914	A	3/2002
JP	2003/209716	A	7/2003
JP	2003/348379	A	12/2003
JP	2004/140759	A	5/2004
JP	04/266757	A	9/2004
JP	2006/094420	A	4/2006
JP	2006-128744	A	5/2006
JP	2006/180268	A	7/2006

JP	06/317406	A	11/2006
JP	07/317109	A	12/2007
JP	08/042407	A	2/2008
JP	08/123349	A	5/2008
JP	2008-107893	A	5/2008
JP	08/141658	A	6/2008
JP	2009-266233	A	11/2009
JP	2010-273168	A	12/2010

OTHER PUBLICATIONS

USPTO Office Action—U.S. Appl. No. 13/434,717—Notification Date Jan. 24, 2013.

USPTO Office Action—U.S. Appl. No. 12/882,865—Notification Date Jan. 30, 2013.

International Search Report—International Application No. PCT/JP2013/000210—Mailing Date Feb. 26, 2013.

USPTO Notice of Allowance—U.S. Appl. No. 12/892,803—Date Mailed: Mar. 26, 2013.

Yuki Ishii, “Fresh Eyes—Introduction of Video Research Laboratory,” The Journal of Institute of Image Information and Television Engineers, Jan. 1, 2008, pp. 52-54, vol. 62, No. 1.

C. Tomasi and R. Manduchi, “Bilateral Filtering for Gray and Color Images,” Proceedings of the 1998 IEEE International Conference on Computer Vision, Jan. 1998, pp. 839-846.

Pietro Perona and Jitendra Malik, “Scale-Space and Edge Detection Using Anisotropic Diffusion,” IEEE Transactions on Pattern Analysis and Machine Intelligence, Jul. 1990, pp. 629-639, vol. 12, No. 7.

International Search Report—Patent Application No. PCT/JP2011/055567—Mailing Date Jun. 7, 2011.

Choi and Kim, “Blocking-Artifact Reduction in Block-Coded Images Using Wavelet-Based Subband Decomposition,” IEEE Transaction on Circuits and Systems for Video Technology, vol. 10, No. 5, Aug. 2000.

Sezan et al., Temporally Adaptive Filtering of Noisy Image Sequences Using a Robust Motion Estimation Algorithm, in Proceedings of the International Conference on Acoustics, Speech, Signal Processing, vol. 91, 1991, pp. 2429-2432.

Purushothaman et al., “Compression Block Artifact Reduction in Low Bit Rate Images and Videos,” European Journal of Scientific Research, ISSN 1450-216X, vol. 64, No. 2, 2011, pp. 244-253.

Ozkan et al., “Adaptive Motion-Compensated Filtering of Noisy Image Sequences,” IEEE transactions on Circuits and Systems for Video Technology, vol. 3, No. 4, Aug. 1993.

USPTO Office Action—U.S. Appl. No. 12/892,803—Mailing Date Oct. 12, 2012.

International Search Report—International Application No. PCT/JP2011/054679—Mailing Date Apr. 12, 2011.

International Search Report—International Application No. PCT/JP2011/055870—Mailing Date Jun. 6, 2011.

USPTO Notice of Allowance—U.S. Appl. No. 12/892,816—Mailing Date Oct. 5, 2011.

International Search Report—International Application No. PCT/JP2011/071167—Mailing Date Dec. 6, 2011.

USPTO Office Action—U.S. Appl. No. 12/882,865—Notification Date: May 13, 2013.

USPTO Notice of Allowance—U.S. Appl. No. 13/434,717—Date Mailed: May 14, 2013.

* cited by examiner

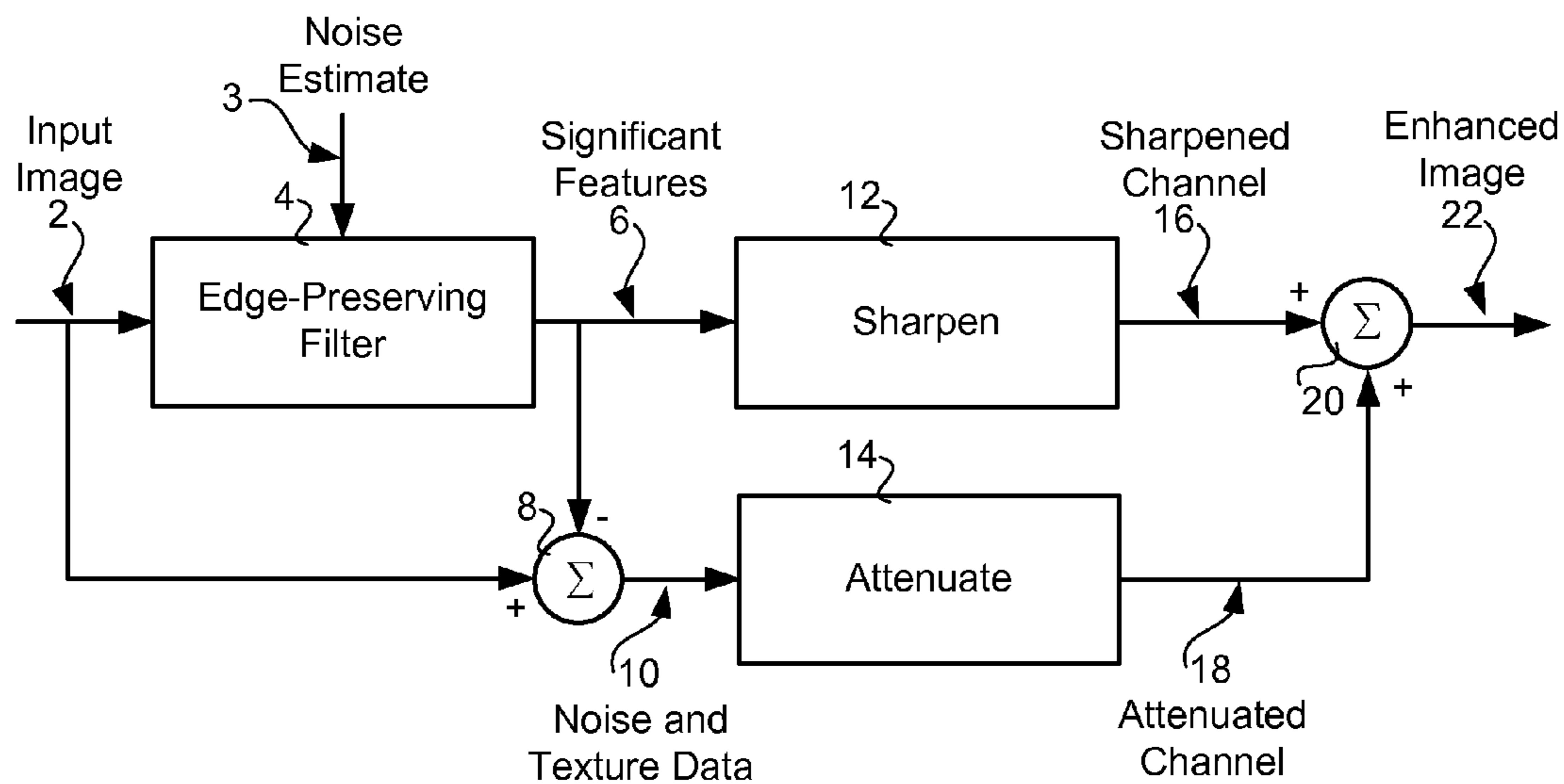

FIG. 1

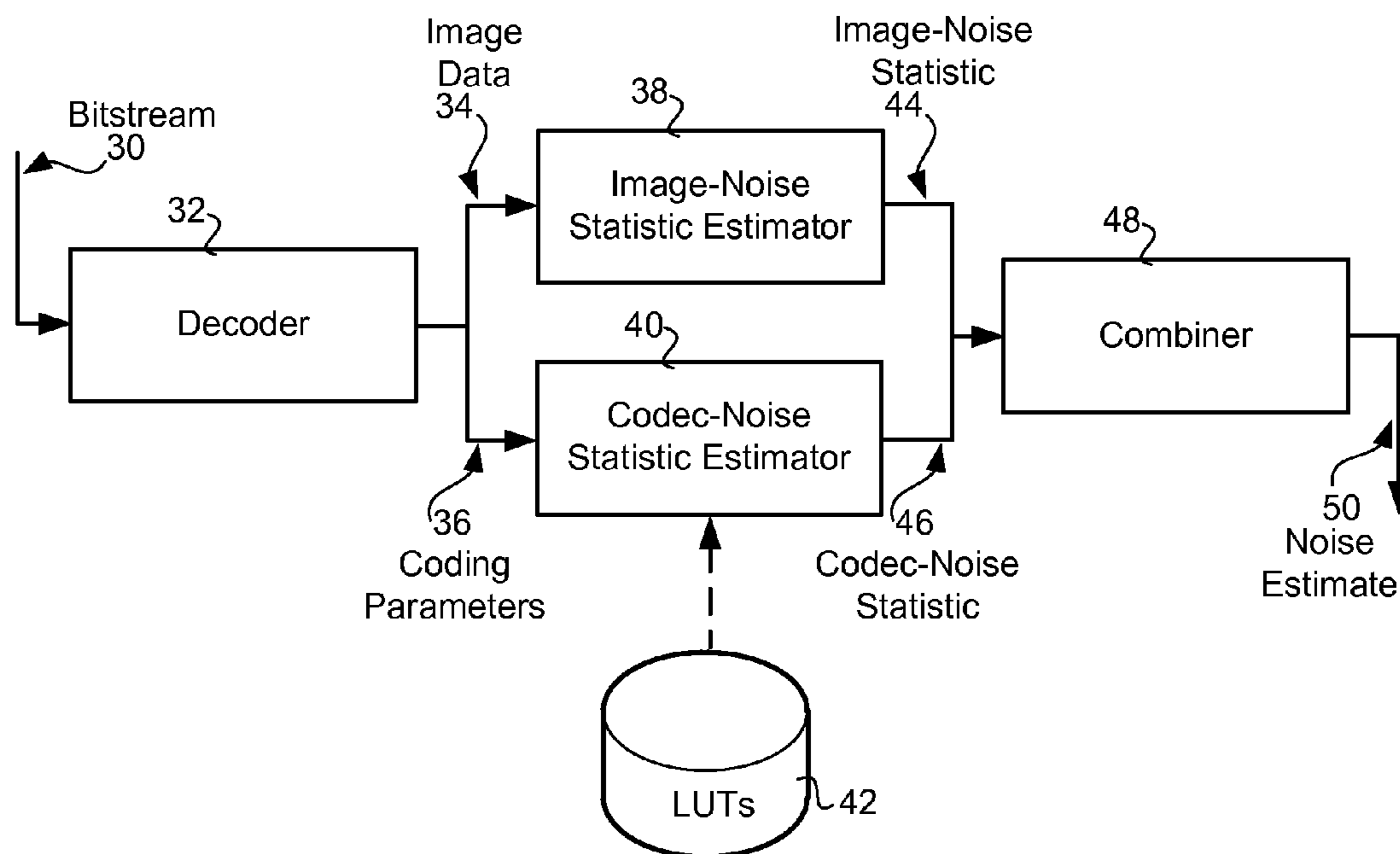

FIG. 2

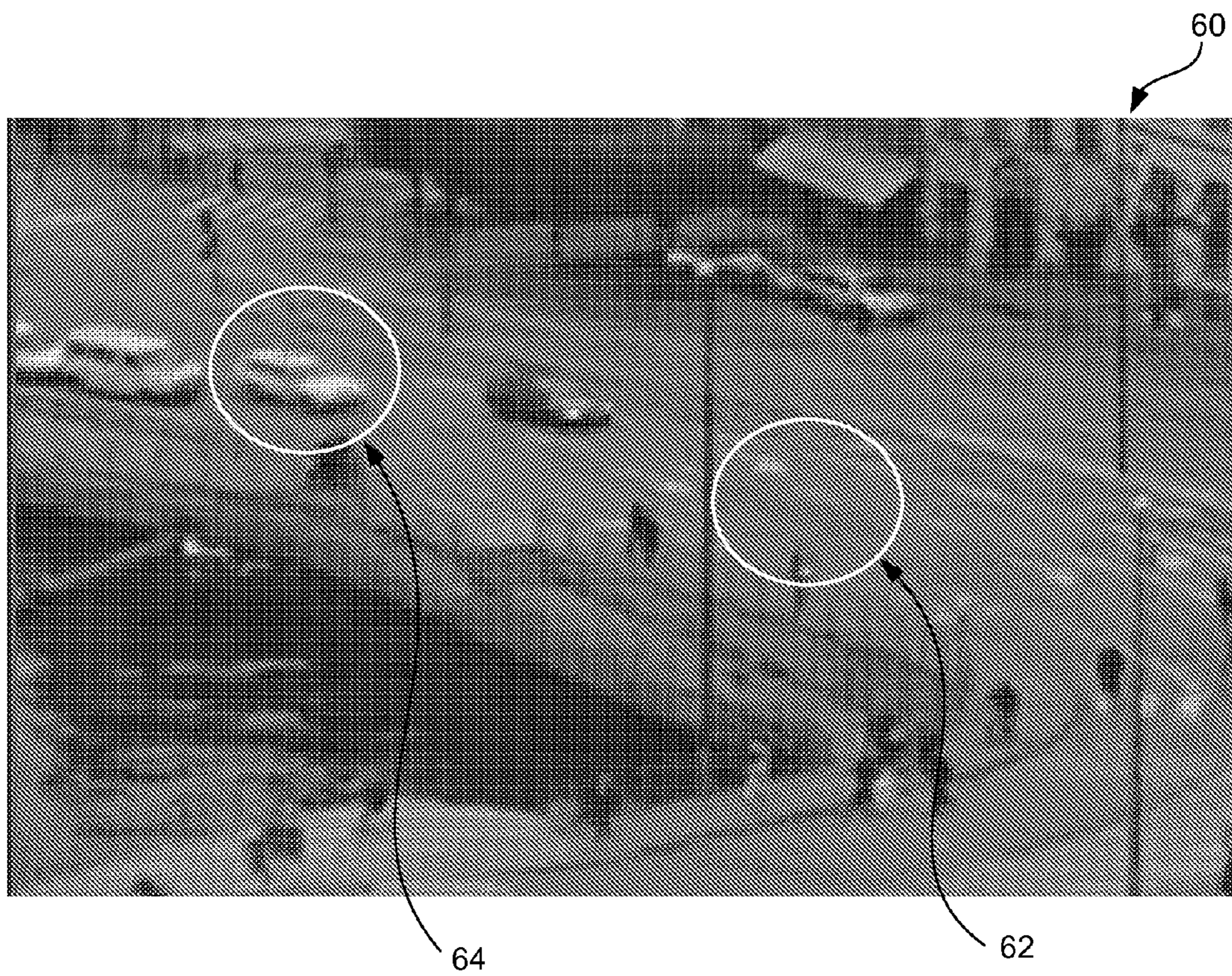

FIG. 3

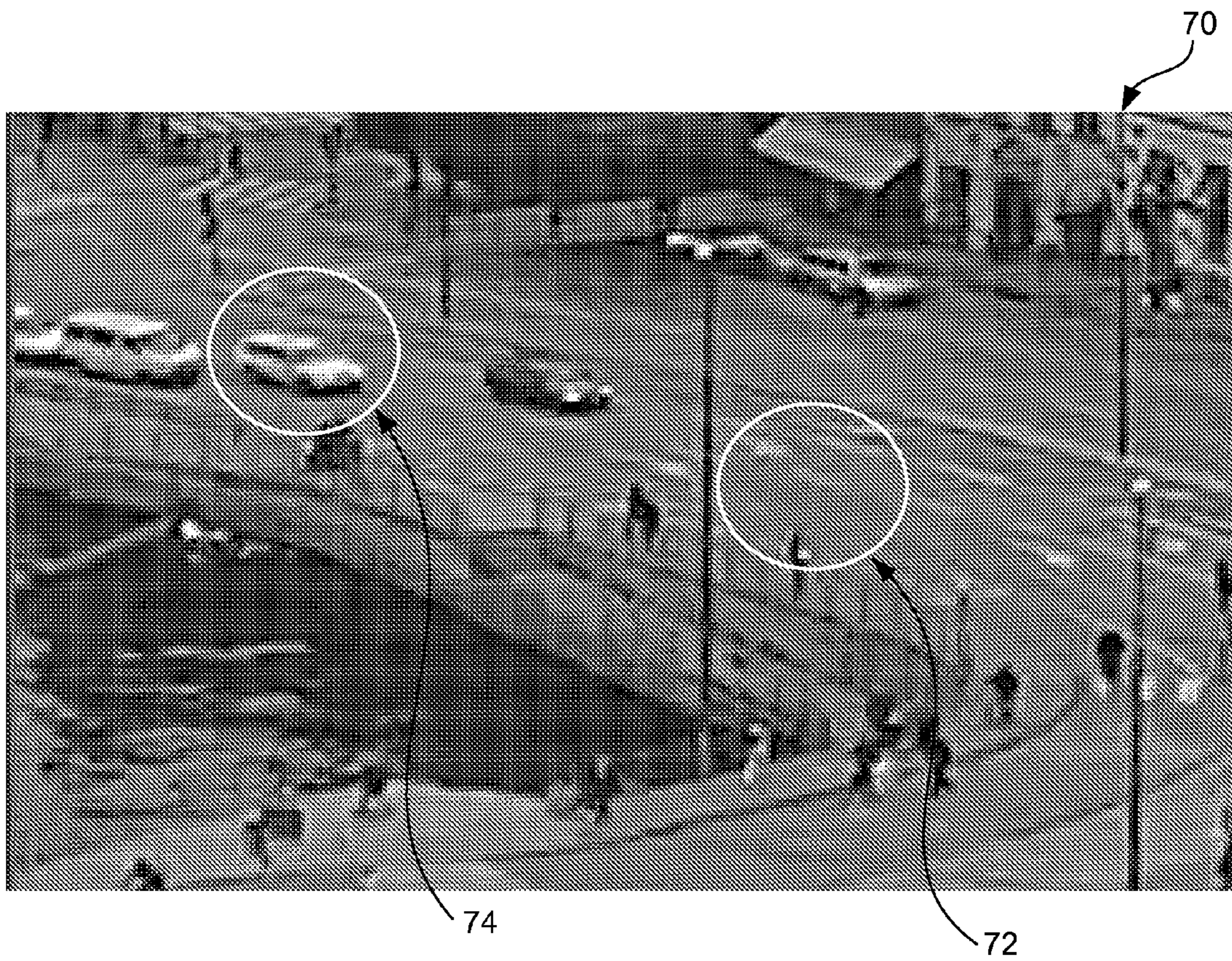

FIG. 4

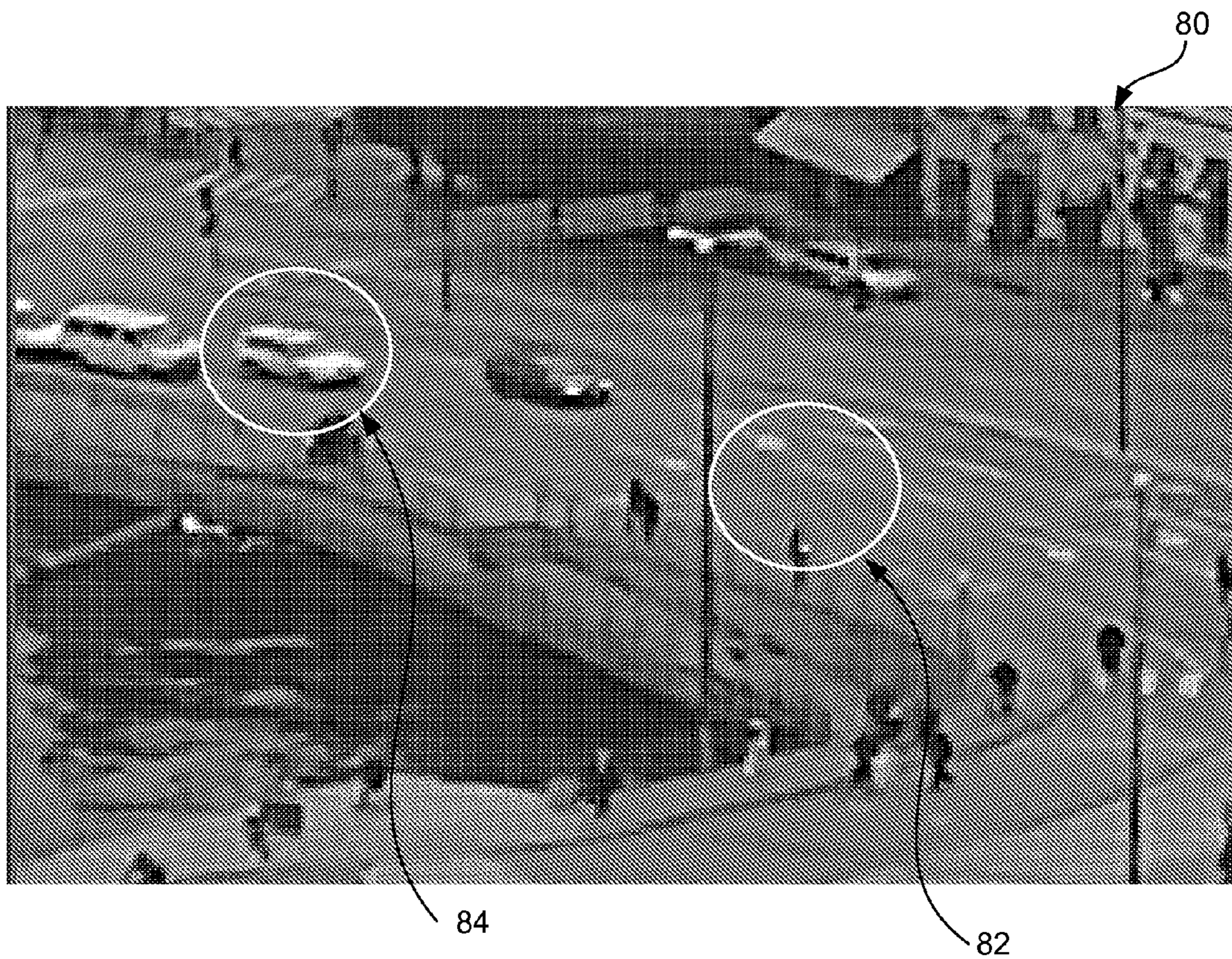

FIG. 5



FIG. 6



FIG. 7



FIG. 8

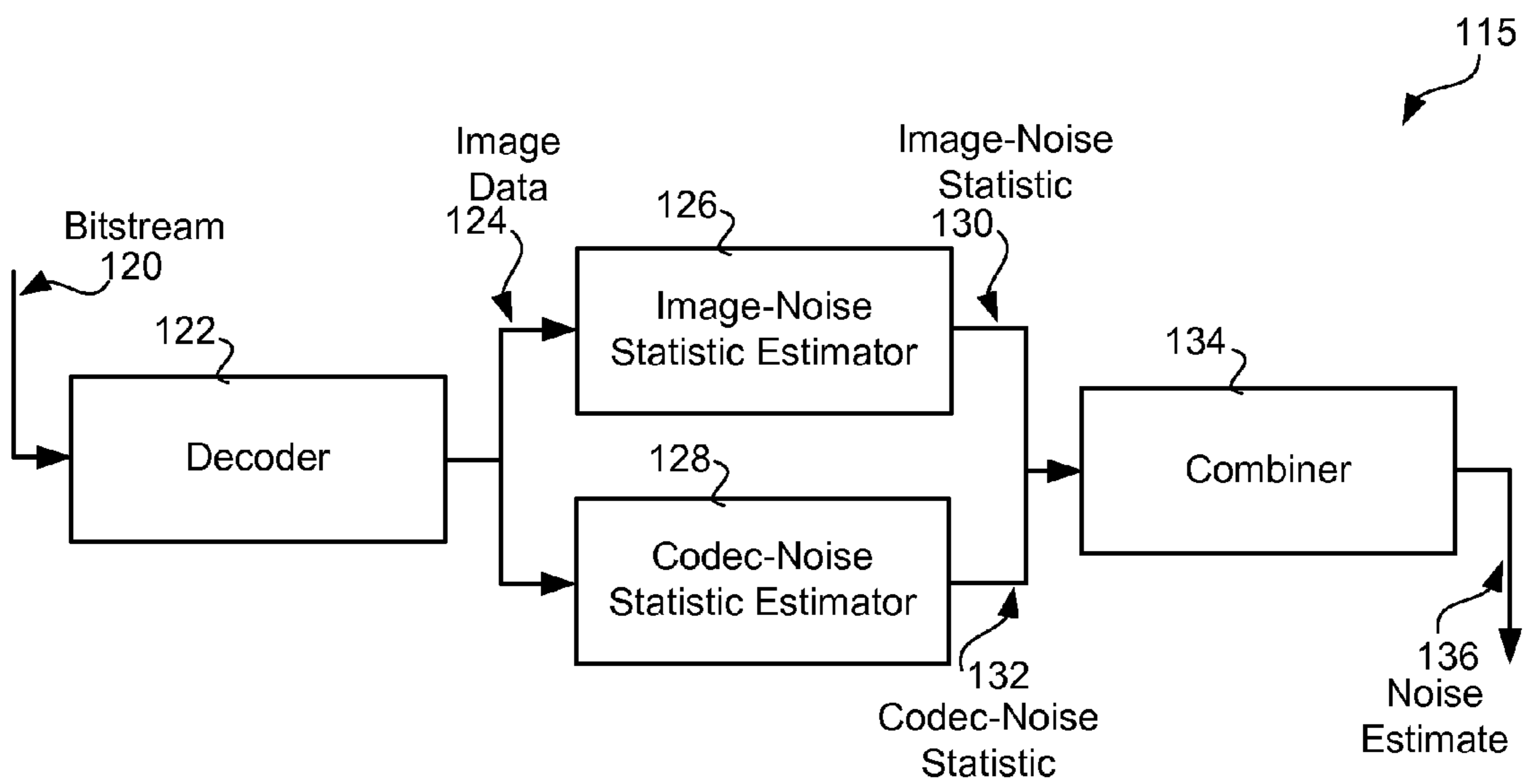

FIG. 9

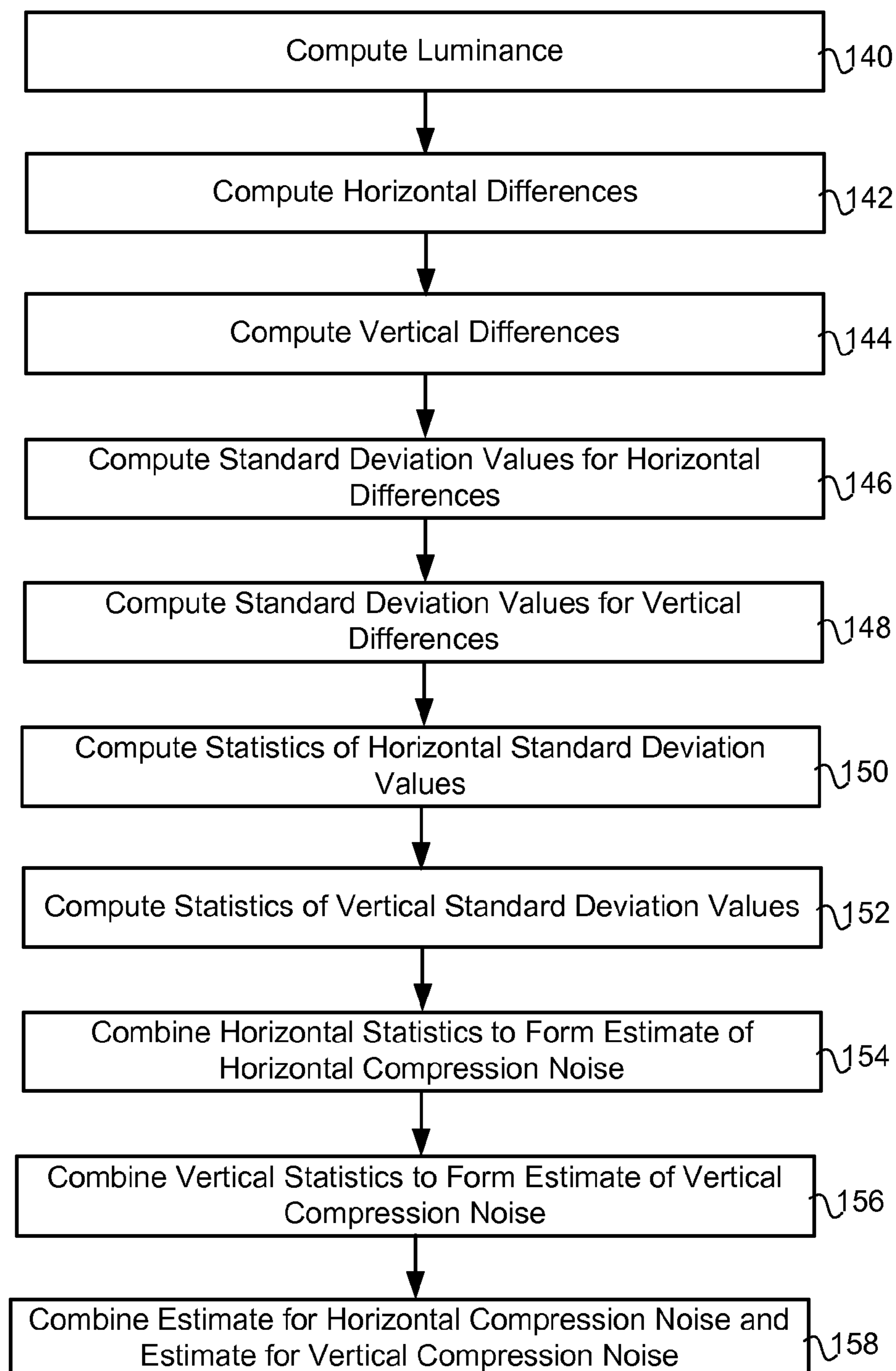

FIG. 10

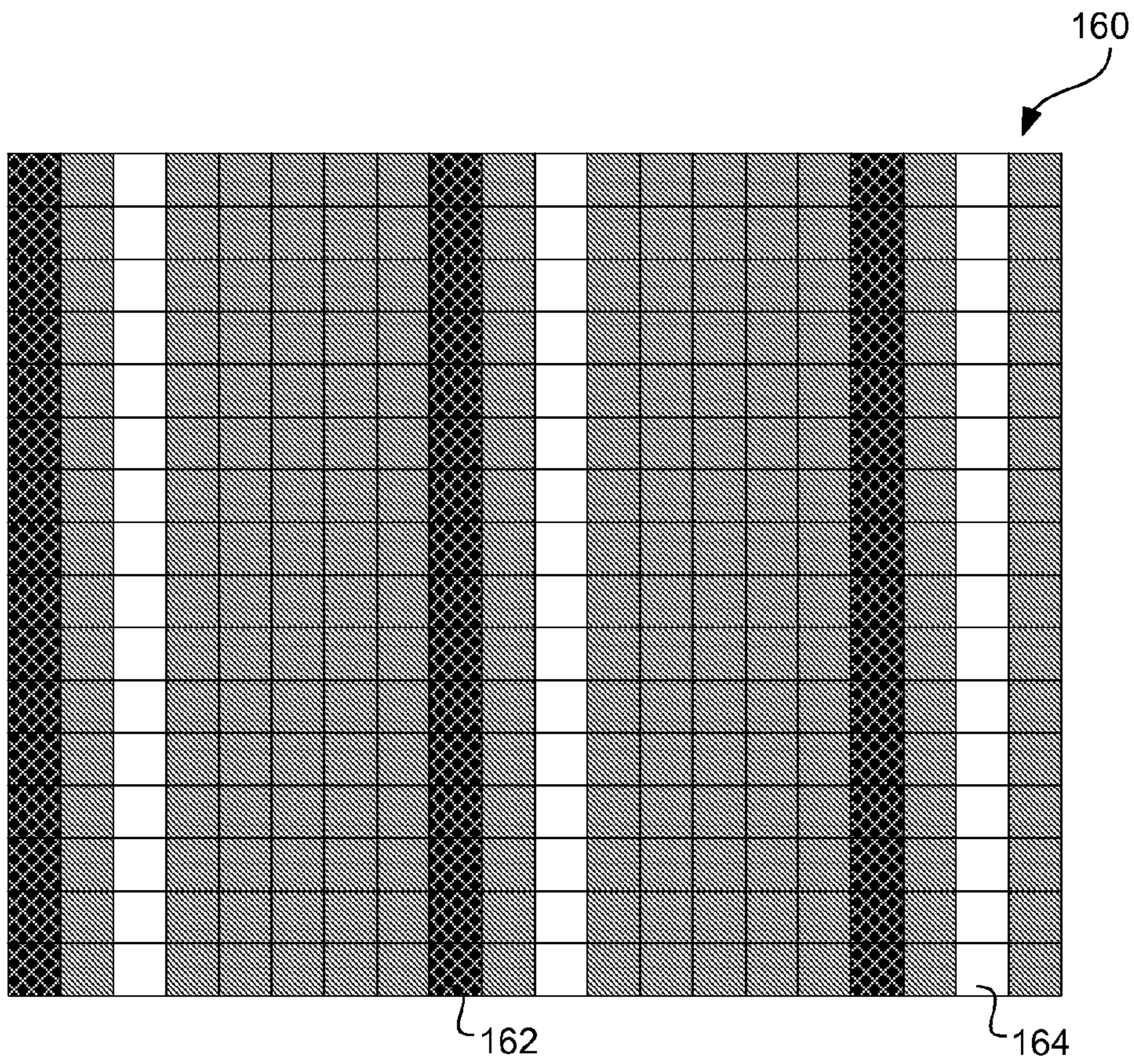

FIG. 11

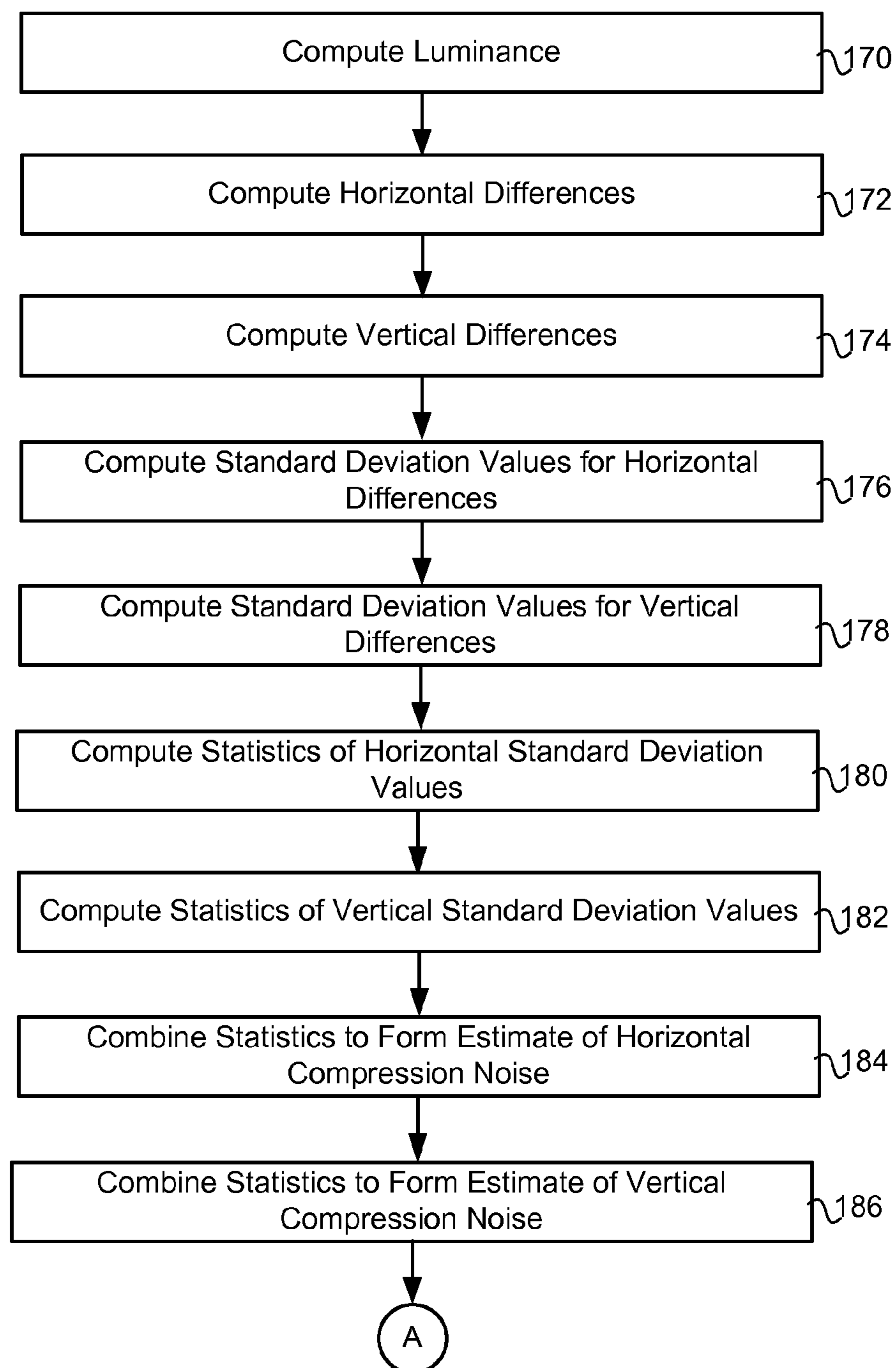

FIG. 12

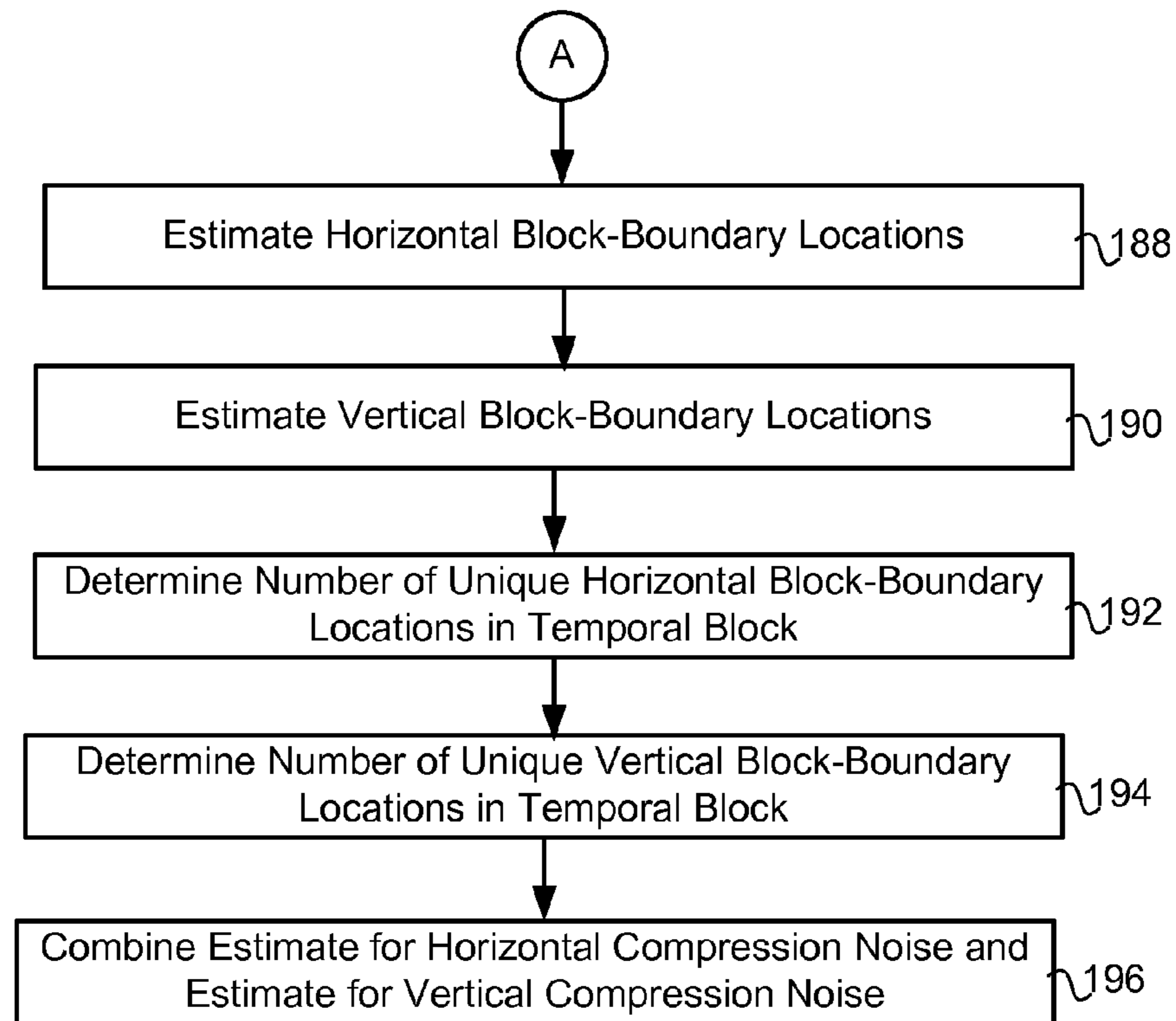

FIG. 12 CONTINUED

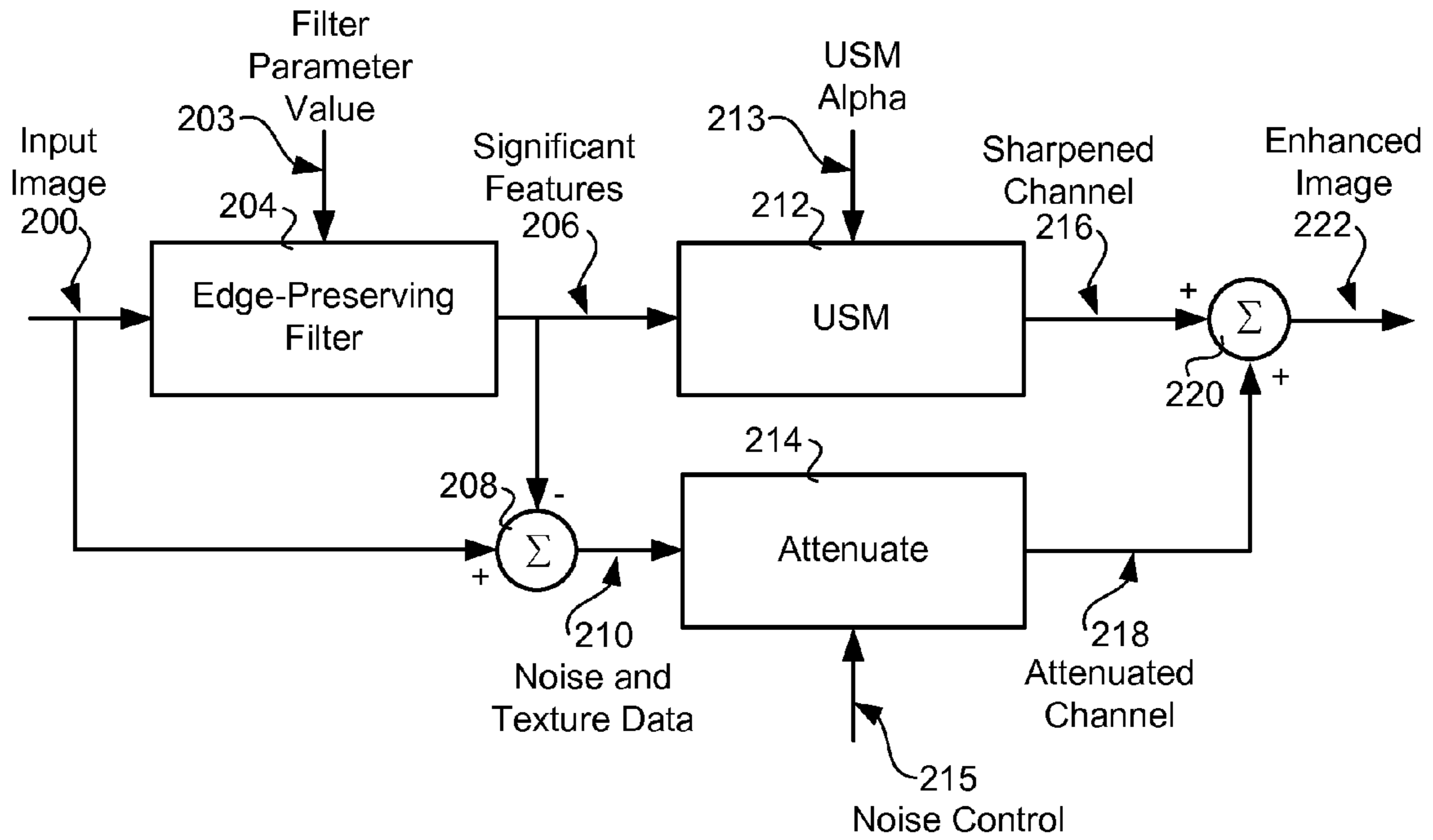

FIG. 13

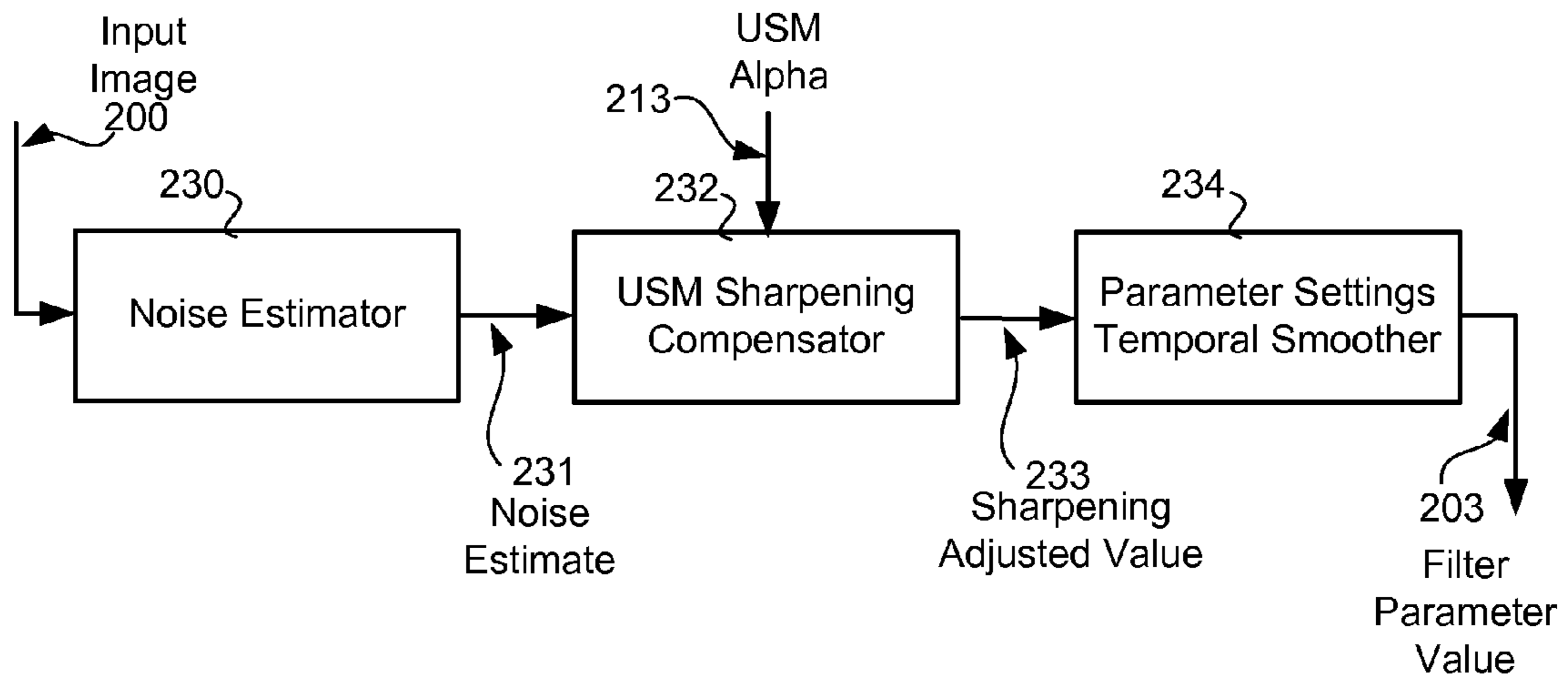

FIG. 14

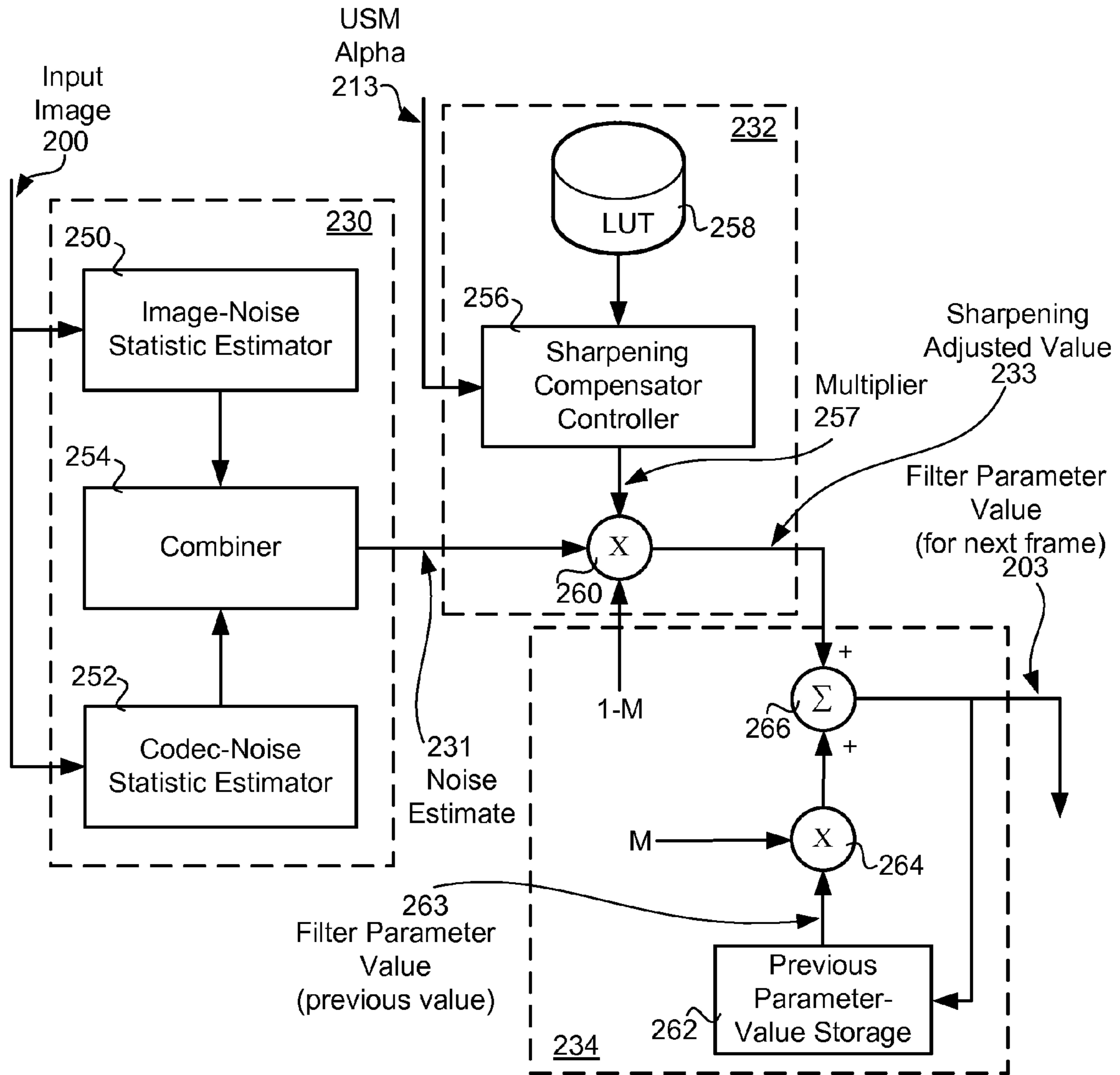

FIG. 15

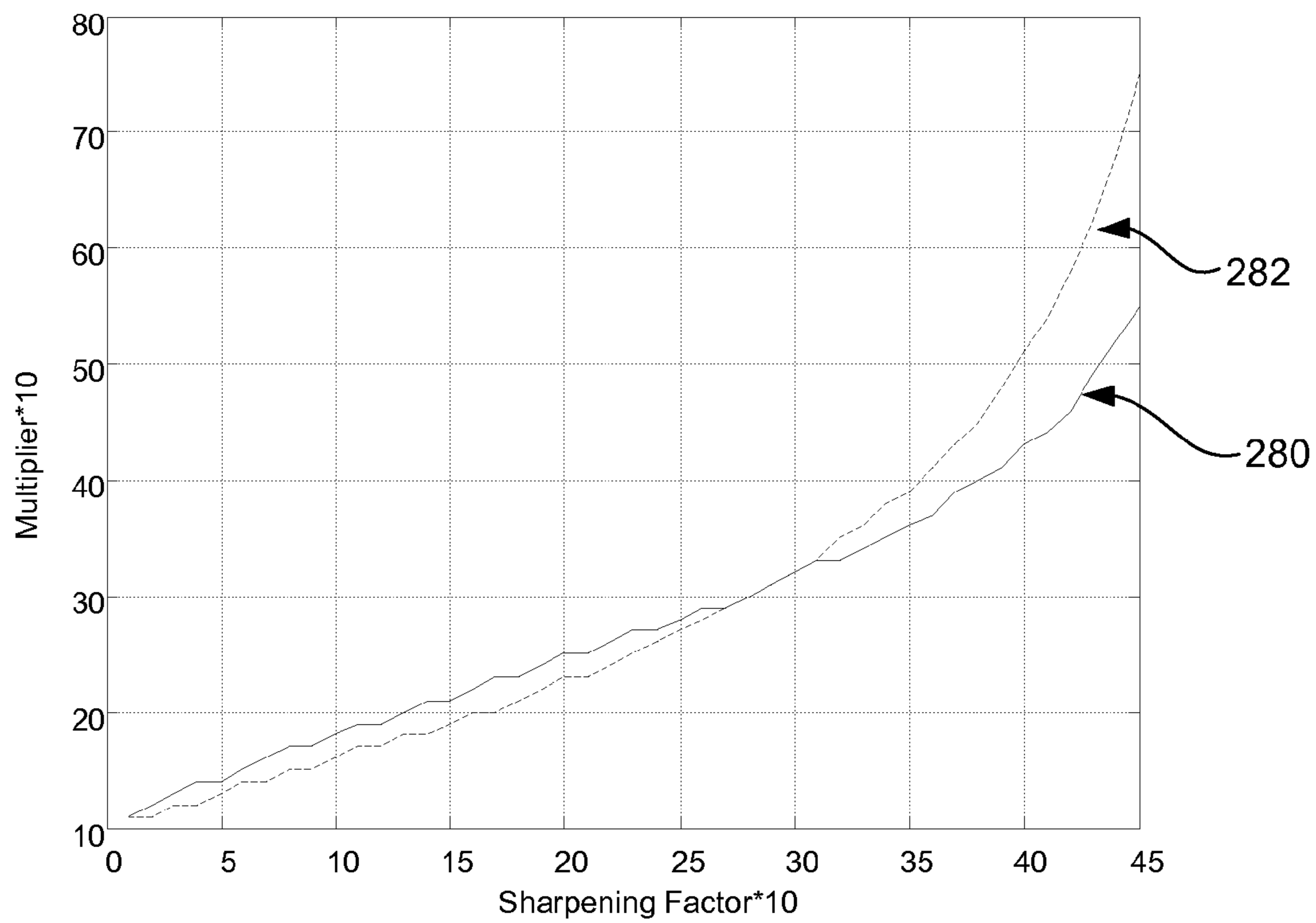

FIG. 16

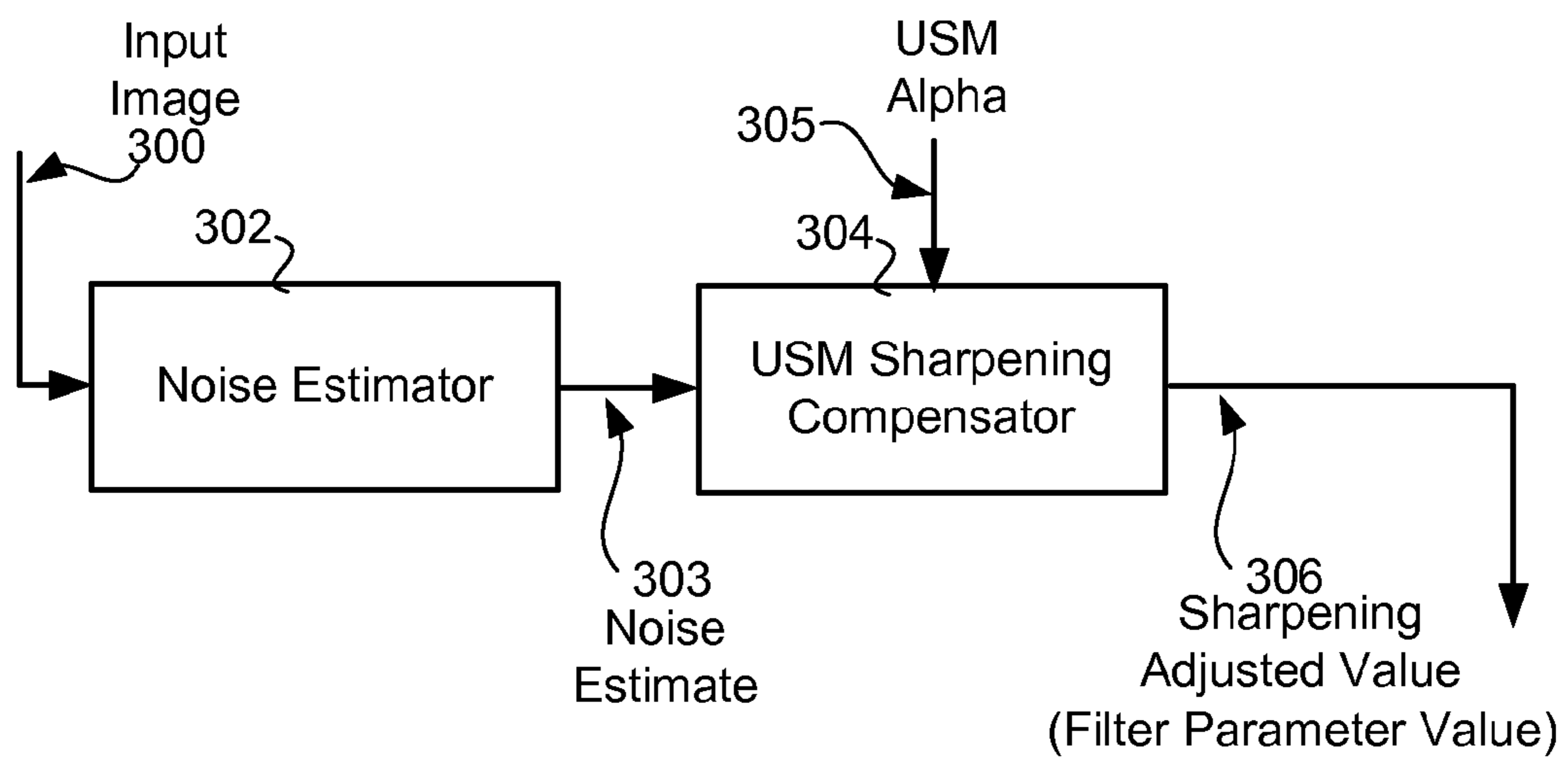

FIG. 17

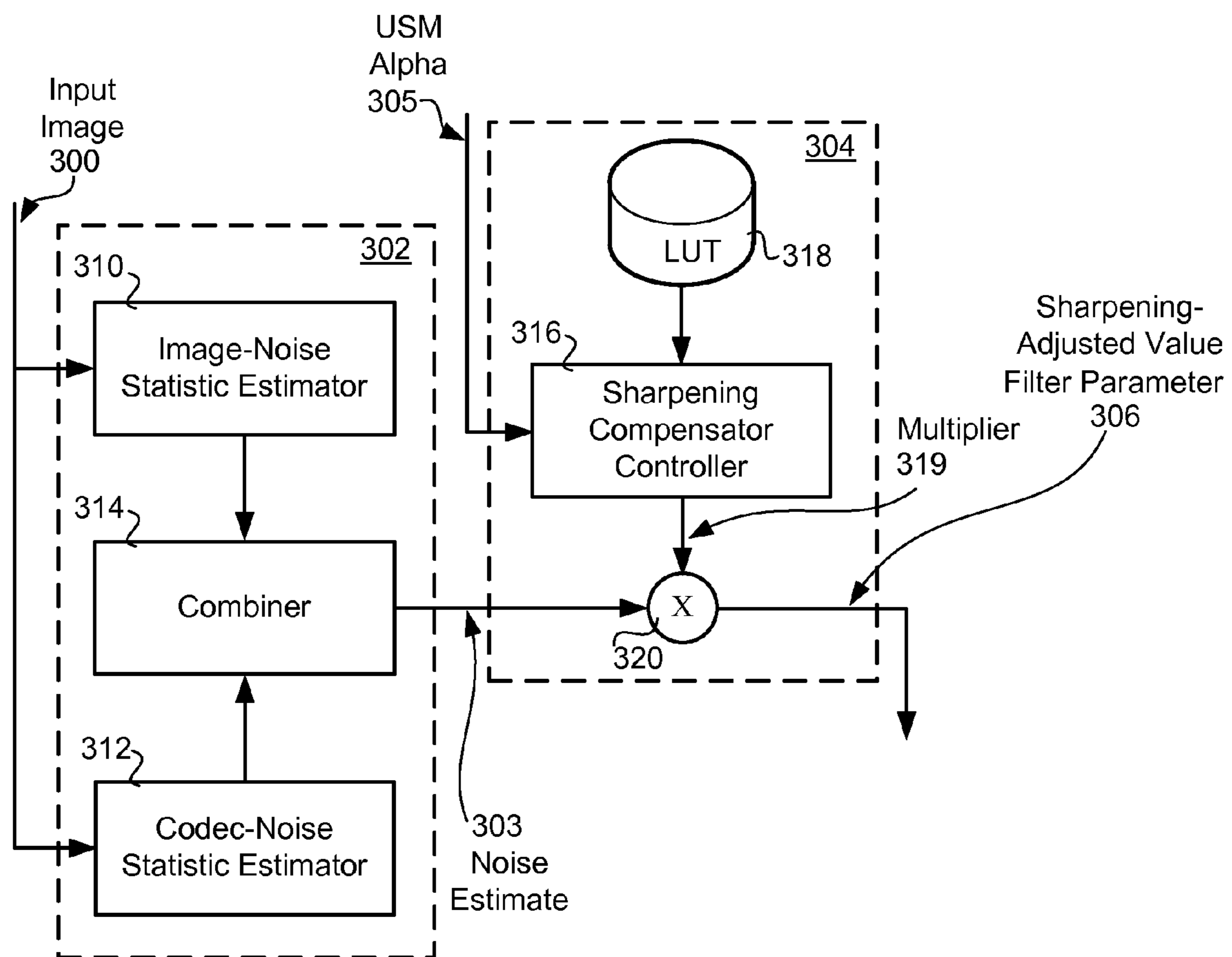

FIG. 18

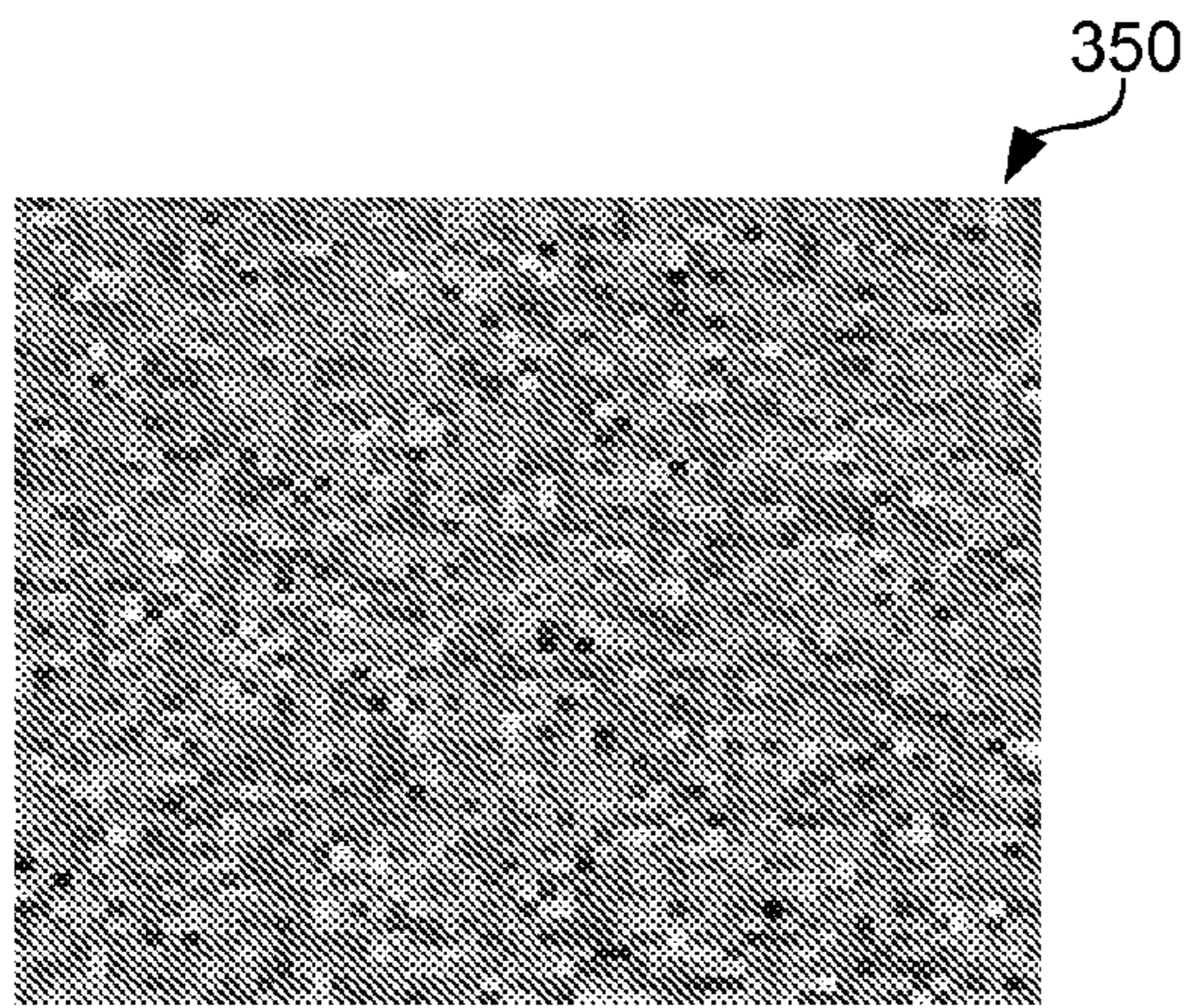

FIG. 19

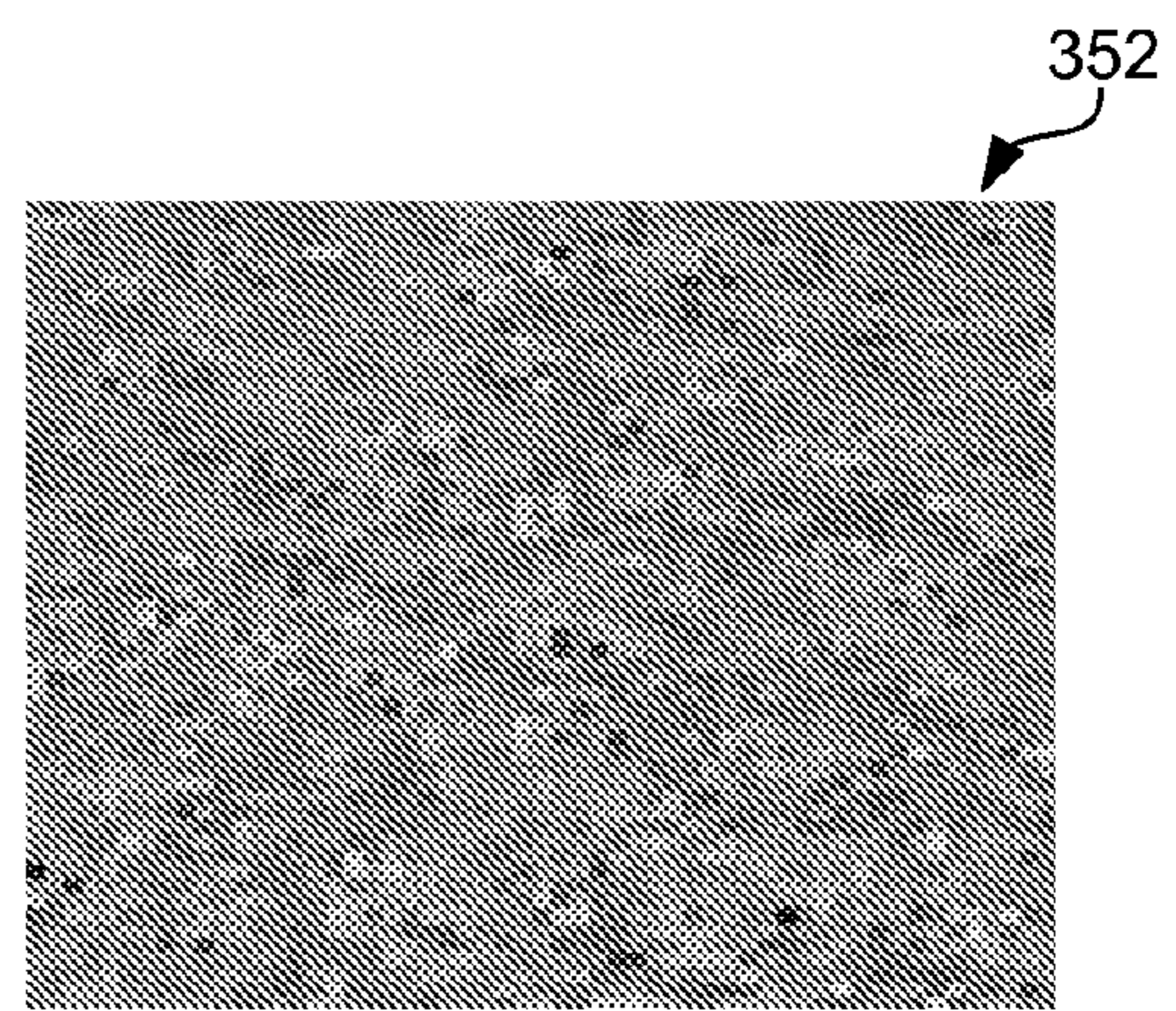

FIG. 20

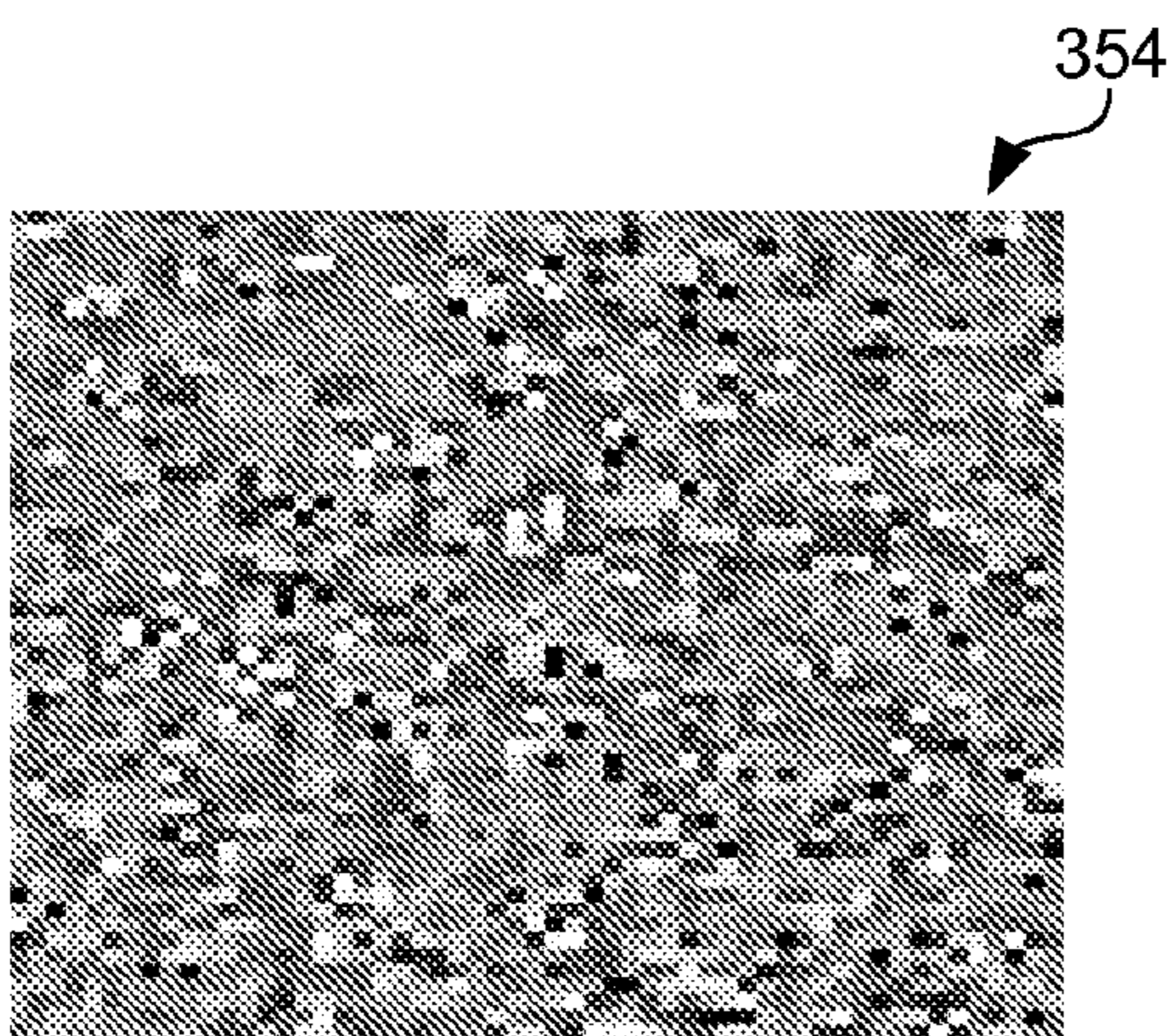

FIG. 21

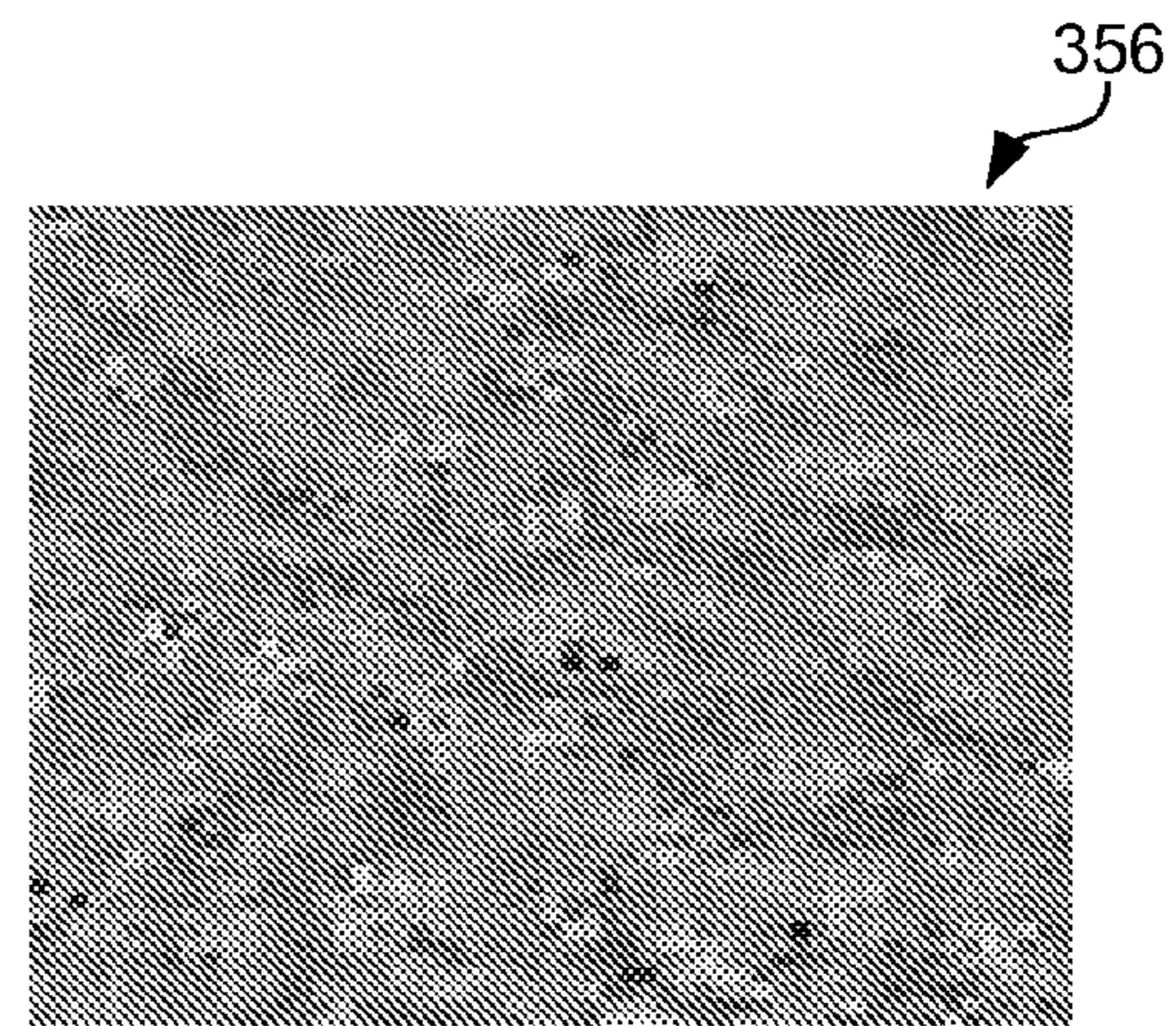
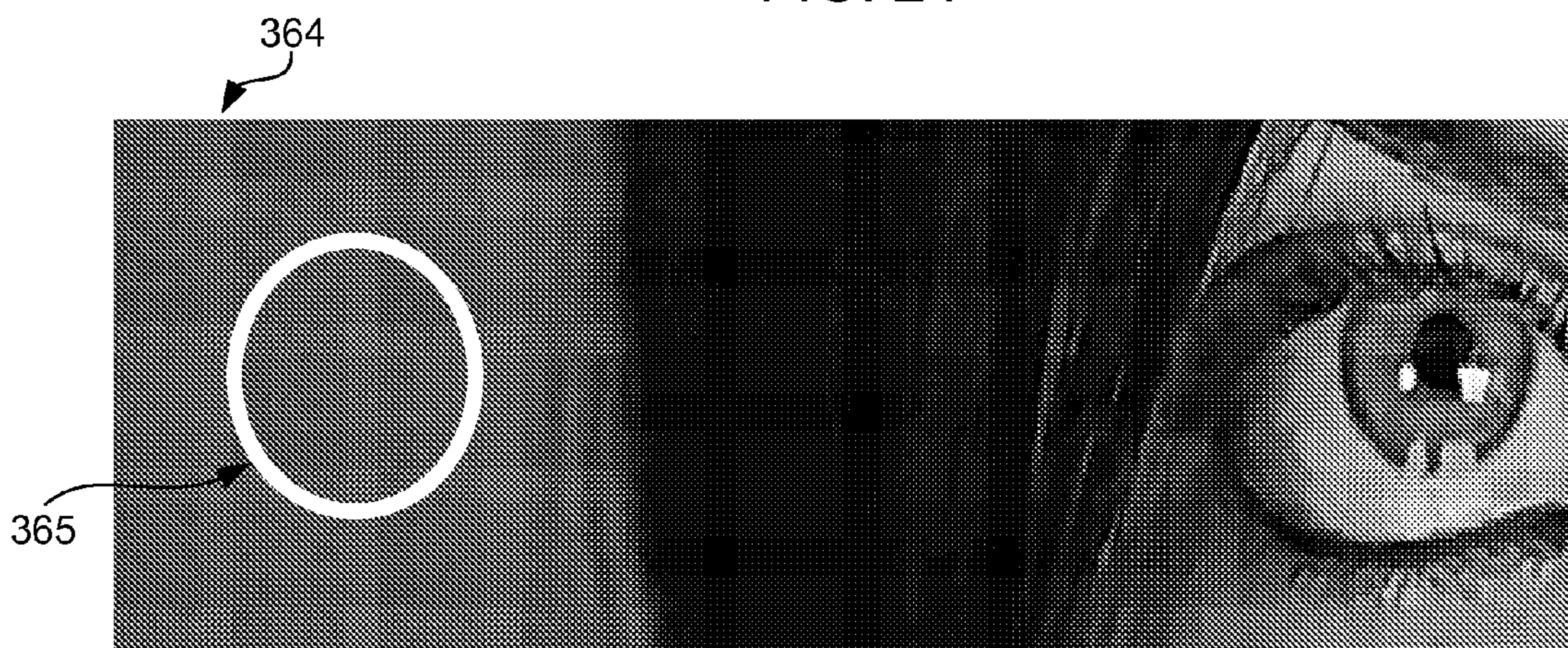

FIG. 22



1**METHODS AND SYSTEMS FOR
ESTIMATION OF COMPRESSION NOISE**

FIELD OF THE INVENTION

The present invention relates to image and video processing and, in particular, to methods and systems for estimating compression noise in an image or in a video sequence.

BACKGROUND

The quality of a video sequence or of an image may vary widely depending on the source. For example, computer-generated content may be of the highest quality, packaged media content, for example, Blu-ray media, may be of relatively high quality, over-the-air high-definition (HD) broadcast content may be of relatively intermediate quality, while content distributed via cable and satellite, may be of a relatively lower quality and Internet protocol television (IPTV) and streamed content may be of relatively low quality. Methods and systems for video and image enhancement that automatically adapt to image- or video-content quality may be desirable.

SUMMARY

Some embodiments of the present invention comprise methods and systems for estimating compression noise in an image or a video sequence.

According to a first aspect of the present invention, statistics based on standard deviations of horizontal differences and statistics based on standard deviations of vertical differences may be used to estimate horizontal compression noise and vertical compression noise, respectively. The estimated horizontal compression noise and the estimated vertical compression noise may be combined to form a compression noise estimate.

According to a second aspect of the present invention, statistics based on standard deviations of horizontal differences and statistics based on standard deviations of vertical differences may be used to estimate horizontal compression noise and vertical compression noise, respectively. Horizontal block-boundaries and vertical block-boundaries may be detected and examined for a plurality of video frames. The horizontal compression noise estimate may be set to zero based on the horizontal block boundaries, and the vertical compression noise estimate may be set to zero based on the vertical block boundaries.

According to a third aspect of the present invention, an edge-preserving filter may be controlled based on the estimated compression noise estimate.

According to a fourth aspect of the present invention, a bi-lateral filter may be controlled based on the estimated compression noise estimate.

The foregoing and other objectives, features, and advantages of the invention will be more readily understood upon consideration of the following detailed description of the invention taken in conjunction with the accompanying drawings.

BRIEF DESCRIPTION OF THE SEVERAL
DRAWINGS

FIG. 1 is a chart showing exemplary embodiments of the present invention comprising controlling the image separation effectuated by an edge-preserving filter using an estimate of the noise in the input image;

2

FIG. 2 is a chart showing exemplary embodiments of the present invention comprising estimation of compression noise by accessing a look-up table;

FIG. 3 is an exemplary, original, decoded image frame;

FIG. 4 is an enhanced image resulting from processing, according to embodiments of the present invention, of the exemplary, original, decoded image frame shown in FIG. 3, wherein the noise estimate used to control the bi-lateral filter parameter value was based only on sensor, thermal and grain noise;

FIG. 5 is an enhanced image resulting from processing, according to embodiments of the present invention, of the exemplary, original, decoded image frame shown in FIG. 3, wherein the noise estimate used to control the bi-lateral filter parameter value was based on sensor, thermal and grain noise and compression noise;

FIG. 6 is an exemplary, original, decoded image frame associated with a lightly compressed image;

FIG. 7 is an enhanced image resulting from processing, according to embodiments of the present invention, of the exemplary, original decoded image frame shown in FIG. 6, wherein the noise estimate used to control the bi-lateral filter parameter value was based only on compression noise;

FIG. 8 is an enhanced image resulting from processing, according to embodiments of the present invention, of the exemplary, original decoded image frame shown in FIG. 6, wherein the noise estimate used to control the bi-lateral filter parameter value was based on noise due to sensor, thermal and grain noise and compression noise;

FIG. 9 is a chart showing exemplary embodiments of the present invention comprising estimation of compression noise directly from image data;

FIG. 10 is a chart showing exemplary embodiments of the present invention comprising estimation of compression noise directly from image data for a still image or a single frame in a video sequence;

FIG. 11 is a picture illustrating exemplary pixel locations for determination of horizontal differences according to embodiments of the present invention;

FIG. 12 is a chart showing exemplary embodiments of the present invention comprising estimation of compression noise directly from image data for a frame in a video sequence;

FIG. 13 is chart showing exemplary embodiments of the present invention comprising un-sharp masking;

FIG. 14 is a chart showing exemplary embodiments of the present invention comprising edge-preserving filter parameter value determination based on the level of sharpening associated with the un-sharp masking;

FIG. 15 is a chart showing exemplary embodiments of the present invention comprising edge-preserving filter parameter value determination based on the level of sharpening associated with the un-sharp masking and based on temporal smoothing;

FIG. 16 is a plot showing two exemplary look-up tables for associating a sharpening factor with a multiplier;

FIG. 17 is a chart showing exemplary embodiments of the present invention comprising edge-preserving filter parameter value determination based on the level of sharpening associated with the un-sharp masking;

FIG. 18 is a chart showing an exemplary embodiment of the present invention comprising edge-preserving filter parameter value determination based on the level of sharpening associated with the un-sharp masking;

FIG. 19 is an exemplary, original noise image;

FIG. 20 shows a result of bi-lateral filtering, using a sigma range parameter value equal to the standard deviation of the noise, of the original noise image shown in FIG. 19;

FIG. 21 shows a result of bi-lateral filtering, according to embodiments of the present invention, of the original noise image shown in FIG. 19, where the bi-lateral filter parameter value was set based on the noise in the original noise image;

FIG. 22 shows a result of bi-lateral filtering, according to embodiments of the present invention, of the original noise image shown in FIG. 19, where the bi-lateral filter parameter value was set based on the noise in the original noise image and the level of sharpening;

FIG. 23 shows an exemplary, original image;

FIG. 24 shows a result of bi-lateral filtering, according to embodiments of the present invention, of the original image shown in FIG. 23, where the bi-lateral filter parameter value was set based on noise estimated from the original image; and

FIG. 25 shows a result of bi-lateral filtering, according to embodiments of the present invention, of the original image shown in FIG. 23, where the bi-lateral filter parameter value was set based on noise estimated from the original image and the level of sharpening.

DETAILED DESCRIPTION OF EXEMPLARY EMBODIMENTS

Embodiments of the present invention will be best understood by reference to the drawings, wherein like parts are designated by like numerals throughout. The figures listed above are expressly incorporated as part of this detailed description.

It will be readily understood that the components of the present invention, as generally described and illustrated in the figures herein, could be arranged and designed in a wide variety of different configurations. Thus, the following more detailed description of the embodiments of the methods and systems of the present invention is not intended to limit the scope of the invention but it is merely representative of the presently preferred embodiments of the invention.

Elements of embodiments of the present invention may be embodied in hardware, firmware and/or software. While exemplary embodiments revealed herein may only describe one of these forms, it is to be understood that one skilled in the art would be able to effectuate these elements in any of these forms while resting within the scope of the present invention.

The quality of a video sequence or of an image may vary widely depending on the source. For example, computer-generated content may be of the highest quality, packaged media content, for example, Blu-ray media, may be of relatively high quality, over-the-air high-definition (HD) broadcast content may be of relatively intermediate quality, while content distributed via cable and satellite, may be of a relatively lower quality and Internet protocol television (IPTV) and streamed content may be of relatively low quality. Methods and systems for video and image enhancement that automatically adapt to image- or video-content quality may be desirable.

When there is little, or no, noise in an image, either a still image or a frame in a video sequence, the image may be sharpened aggressively, and small details in the image may not be attenuated. However, selective image sharpening may be required in the presence of noise. Stronger and larger-scale features, as defined relative to the degree of noise, may be identified and enhanced, while less significant and smaller-scale features may be unprocessed, or potentially attenuated to mitigate the noise present in the image.

U.S. patent application Ser. No. 12/228,774, entitled "Image Sharpening Technique," filed Aug. 15, 2008, which is hereby incorporated by reference herein in its entirety, describes a technique for image sharpening wherein two image channels are generated from an image: a first channel which may include primarily texture information and a second channel which may include primarily edge and flat-region information. The first channel may be filtered to attenuate higher frequency content of the image in the first channel, and the second channel may be filtered to sharpen the image in the second channel. The filtered first channel and the filtered second channel may be combined to form an enhanced image associated with the input image.

In some embodiments of the present invention, an edge-preserving filter may be used to separate an input image into two channels: a first channel which may comprise image content to be sharpened; and a second channel which may comprise image content to attenuate. In some embodiments of the present invention, the edge-preserving filter may comprise a bi-lateral filter. In alternative embodiments, another edge-preserving filter may be used to perform the separation. In some embodiments, the assignment of the input-image content to the first channel and the second channel may be controlled by a parameter of the edge-preserving filter. For example, a range sigma parameter of a bi-lateral filter may control the assignment of input-image content to the first channel and the second channel in embodiments wherein the edge-preserving filter comprises a bi-lateral filter. In some embodiments, in order to maximize the amount of sharpening, the filter parameter value, for example, the range sigma parameter value in a bi-lateral filter, may be set based on noise statistics associated with the input image.

Some embodiments of the present invention may be understood in relation to FIG. 1. An input image 2 and a noise estimate 3 associated with the input image 2 may be made available to an edge-preserving filter 4. In some embodiments of the present invention, the edge-preserving filter may comprise a bi-lateral filter. In alternative embodiments, another edge-preserving filter may be used to perform the separation. The edge-preserving filter 4 may be used to divide the input image 2 into two channels 6, 10. A first channel 6 may correspond to significant features in the input image 2, and the second channel 10, formed by removing 8 the first channel 6 from the input image 2, may contain the residual difference between the first channel 6 and the input image 2. The residual difference may comprise noise and texture data. The first channel 6 may be sharpened 12, and the second channel 10 may be attenuated 14. The sharpened channel 16 and the attenuated channel 18 may be combined 20 to form an enhanced image 22. The value of the filter parameter of the edge-preserving filter 4 may control the assignment of input-image content to the first channel 6 and the second channel 10. The value of the filter parameter of the edge-preserving filter 4 may be based on the noise estimate 3. In some embodiments of the present invention, the value of the filter parameter may be proportional to the noise estimate 3. However, the value of the filter parameter may not be equal to zero. In some embodiments, when the noise estimate 3 indicates that the filter parameter should be set to zero, a small, pre-determined value may be assigned to the filter parameter. In alternative embodiments, when the noise estimate 3 indicates that the filter parameter should be set to zero, the edge-preserving filter 4 may pass the input image 2 directly through as the first channel 6, thereby effectuating only sharpened data. In some embodiments of the present invention (not shown), the enhanced image 22 may be up-sampled to a resolution greater than that of the input image 2.

Multiple noise processes may appear in an image or video sequence. At one extreme, an original image may be of very high quality, for example, computer generated imagery. However, other images, or video sequences, may be of lower quality, for example, a sequence or image may be corrupted, during the acquisition process by thermal, sensor, or other noise. In some situations, film grain, or other analog noise, may corrupt an image or video sequence. Furthermore, compression artifacts may corrupt an image or video sequence. The degree of compression artifacts may be related to the bit-rate associated with a video sequence or image. Exemplary bit-rates and quality levels may be high quality Blu-ray discs compressed at approximately 40 Mbps (Mega bits per second), lower quality over-the-air transmissions compressed at approximately 20 Mbps, further lower quality trans-coded cable transmissions compressed at approximately 12 Mbps and lowest quality satellite and IPTV services compressed at less than 10 Mbps.

In some embodiments of the present invention described in relation to FIG. 2, an input bitstream 30, associated with a still image or a video sequence, may be decoded by an appropriate decoder 32. The image data 34 may be made available, to an image-noise statistic estimator 38, from the decoder 32, and the decoded coding parameters 36 may be made available, to a codec (coder/decoder)-noise statistic estimator 40, from the decoder 32. In alternative embodiments, the coding parameters 36 may be made available to the codec-noise statistic estimator 40 through meta-data or other external means.

The image-noise statistic estimator 38 may analyze the image data 34 to determine the amount of thermal, sensor, grain, or other image noise present in the image data 34. Many existing methods are known in the art for estimating the image noise present in image data. In an exemplary embodiment of the present invention, the image-noise statistic estimator 38 may identify one, or more, substantially smooth regions in the image data 34 and may calculate the standard deviation of the pixel values within each region. The maximum standard deviation value may be associated with the image-noise statistic 44.

The codec-noise statistic estimator 40 may receive coding parameters 36 associated with the input bitstream 30. In some embodiments, the coding parameters 36 may comprise the quantization interval used for coding the current slice or frame in a video sequence. In alternative embodiments, the coding parameters 36 may comprise the number of bits used to represent the source data. The coding parameters 36 may be used in a look-up operation to determine the amount of noise due to compression. In some embodiments of the present invention, the codec type may be used to select a look-up table from multiple, pre-computed look-up tables 42. The coding parameters 36 may be used as an index into the selected table, and the output may be a measure of the image noise due to compression 46. The measurement provided by the look-up tables 42 may be normalized, either at the time the look-up tables 42 are created or in a post-processing operation (not shown) to have the same units of measurement as the noise estimate 44 provided by the image-noise statistic estimator 38.

In some embodiments of the present invention, a look-up table 42 may be constructed by selecting multiple images and video sequences that are representative of input data. The images and videos sequences may be compressed using a variety of codecs and codec settings, and each result may be subsequently decoded. The decoded results may be compared to the original data, and the noise due to the compression system may be computed, for example, the standard deviation of the error. This computation may be performed over all

images and video sequences that are compressed using the same codec and parameter settings, and the result may be stored in the look-up table as the noise statistic for the combination of codec and codec parameter settings. In some embodiments, if additional values are needed, the test image and video sequence data may be compressed with the desired configuration settings. In alternative embodiments, noise statistics may be interpolated from values with a similar compression configuration.

The image-noise statistic 44 and the codec-noise statistic 46 may be combined by a combiner 48 to produce a final noise estimate 50, which may be made available to the edge-preserving filter to control the filter parameter. In one embodiment of the present invention, the maximum of the image-noise statistic 44 and the codec-noise statistic 46 may be assigned to the noise estimate 50. Alternative fusion methods for combining 48 the image-noise statistic 44 and the codec-noise statistic 46 may be used to produce a final noise estimate 50 which may be made available to the edge-preserving filter, and the value of the filter parameter of the edge-preserving filter may be based on the noise estimate. In some embodiments of the present invention, the value of the filter parameter may be proportional to the noise estimate.

The effectiveness of some embodiments of the present invention may be illustrated in FIGS. 3-8. FIG. 3 depicts an exemplary, original, decoded image 60 with two regions 62, 64 that exhibit coding artifacts shown inside two white circles superimposed on the image 60. One region 62 is along the road, and another region 64 is around a car. FIG. 4 shows an enhancement 70 of the decoded image 60 shown in FIG. 3. The enhanced image 70 was generated using a bi-lateral filter using only an estimate of the image noise to select the range sigma parameter value of the bi-lateral filter. The coding artifacts are visibly enhanced, for example, the regions 72, 74 that are shown in the two superimposed, white circles. However, the enhanced image 80 shown in FIG. 5, by contrast, was enhanced according to embodiments of the present invention wherein a noise estimate accounting for both the image noise, for example, sensor, thermal, grain and other image noise, and the compression noise in the image frame was used to select the range sigma parameter value of the bi-lateral filter. Using this noise estimate produces an enhanced image 80, but without amplifying the coding artifacts, for example, again examine the regions 82, 84 inside the superimposed, white circles.

A second exemplary, original, decoded image 90 is depicted in FIG. 6. Here, the image 90 is the result of light compression. Inspection of FIG. 6 shows a significant amount of grain noise, which may become much more visible if enhanced. Shown in FIG. 7 is an enhanced image 100 wherein the noise estimate controlling the parameter selection in the bi-lateral filter considered only the coding noise. As can be seen in FIG. 7, the enhanced image 100 contains amplified grain noise. However, the enhanced image 110 shown in FIG. 8 resulting from image enhancement according to embodiments of the present invention wherein the noise estimate used to select the range sigma parameter for the bi-lateral filter accounted for both the image noise, for example, sensor, thermal, grain and other noise, and the compression noise in an image frame. As can be seen from FIG. 8, the resulting image is enhanced but without amplifying grain noise artifacts.

Embodiments of the present invention described in relation to FIG. 2 comprise codec-noise statistic estimation from the coding parameters. In alternative embodiments described in relation to FIG. 9, the compression noise may be estimated from the decoded image data.

In some embodiments of the present invention, described in relation to FIG. 9, comprising a noise-estimation system **115**, an input bitstream **120**, associated with a still image or a video sequence, may be decoded by a decoder **122**. The image data **124** may be made available, from the decoder **122**, to an image-noise statistic estimator **126** and to a codec-noise statistic estimator **128**. The image-noise statistic estimator **126** may estimate an image-noise statistic **130** associated with the amount of image noise present in the image data **124**, and the codec-noise statistic estimator **128** may estimate a codec-noise statistic **132** associated with the compression noise. The image-noise statistic **130** and the codec-noise statistic **132** may be combined by a combiner **134** to produce a final noise estimate **136** associated with the image data. In one embodiment of the present invention, the maximum value of the image-noise statistic **130** and the codec-noise statistic **132** may be assigned to the noise estimate **136**. Alternative fusion methods for combining **134** the image-noise statistic **130** and the codec-noise statistic **132** may be used to produce a final noise estimate **136**.

The image-noise statistic estimator **126** may analyze the image data **124** to determine the amount of thermal, sensor, grain and other image noise present in the image data **124**. Many existing methods are known in the art for estimating the image noise. In an exemplary embodiment of the present invention, the image-noise statistic estimator **126** may identify one, or more, substantially smooth regions in the image data **124** and may calculate the standard deviation of the pixel values within each region. The maximum standard-deviation value may be associated with the image-noise statistic **130**.

In some embodiments of the present invention, the codec-noise statistic estimator **128** may calculate an estimate for the codec noise **132** according to FIG. 10. In these embodiments, a luminance image may be computed **140** from an input RGB (Red Green Blue), or other color space, image. The luminance may be denoted $I(x,y)$, where x and y may denote the horizontal and vertical indices, respectively. A horizontal difference value at each point may be computed **142**, thereby producing a plurality of horizontal difference values, and a vertical difference value at each point may be computed **144**, thereby producing a plurality of vertical difference values, according to:

$$D_H(x,y)=I(x+1,y)-I(x,y)$$

and

$$D_V(x,y)=I(x,y+1)-I(x,y),$$

respectively, where $D_H(x,y)$ may denote a horizontal difference value at pixel location (x,y) and $D_V(x,y)$ may denote a vertical difference value at pixel location (x,y) .

The standard deviation of the horizontal differences at a plurality of horizontal offsets may be computed **146**, and the standard deviation of the vertical differences at a plurality of vertical offsets may be computed **148**. In some embodiments of the present invention, a standard deviation value may be calculated for each offset within a coding block, thereby producing a plurality of horizontal standard deviation values and a plurality of vertical standard deviation values. The number of offsets may be determined by the structure of the image, or video, codec and any processing or scaling of the decoded data that may be performed prior to estimating the compression noise. In an exemplary embodiment comprising the use of eight offsets, the standard deviation values of the horizontal differences may be calculated **146** according to:

$$\text{Mean}_H[i] = \sum_{x=0}^{\text{Height}} \sum_{y=0}^{\frac{\text{Width}}{8}} \frac{D_H(x, 8 \cdot y + i)}{\text{Height} \cdot (\text{Width}/8)}, i = 0 \dots 7$$

$$\text{Mean2}_H[i] = \sum_{x=0}^{\text{Height}} \sum_{y=0}^{\frac{\text{Width}}{8}} \frac{D_H(x, 8 \cdot y + i)^2}{\text{Height} \cdot (\text{Width}/8)}, i = 0 \dots 7$$

$$\text{STD}_H[i] = \text{sqrt}(\text{Mean2}_H[i] - \text{Mean}_H[i]^2), i = 0 \dots 7.$$

FIG. 11 depicts an exemplary portion of an image **160** with pixel locations shown as squares. The pixel locations shown in cross hatch, for example **162**, may be the locations used for computing the horizontal standard deviation associated with an offset of zero, $\text{STD}_V[0]$, and the pixel locations shown in white, for example **164**, may be the locations used for computing the horizontal standard deviation associated with an offset of two, $\text{STD}_V[2]$. The standard deviation values of the vertical differences may be similarly calculated **148** according to:

$$\text{Mean}_V[i] = \sum_{x=0}^{\frac{\text{Height}}{8}} \sum_{y=0}^{\text{Width}} \frac{D_V(8 \cdot x + i, y)}{(\text{Height}/8) \cdot \text{Width}}, i = 0 \dots 7$$

$$\text{Mean2}_V[i] = \sum_{x=0}^{\frac{\text{Height}}{8}} \sum_{y=0}^{\text{Width}} \frac{D_V(8 \cdot x + i, y)^2}{(\text{Height}/8) \cdot \text{Width}}, i = 0 \dots 7$$

$$\text{STD}_V[i] = \text{sqrt}(\text{Mean2}_V[i] - \text{Mean}_V[i]^2), i = 0 \dots 7.$$

Referring again to FIG. 10, statistics may be computed **150** for the horizontal standard deviation values, and statistics may be computed **152** for the vertical standard deviation values. The statistics computed **150** for the horizontal standard deviation values may be referred to as horizontal statistics and the statistics computed **152** for the vertical standard deviation values may be referred to as vertical statistics. In some embodiments of the present invention, the average of the horizontal standard deviation values and the maximum horizontal standard deviation value may be computed **150**, and the average of the vertical standard deviation values and the maximum vertical standard deviation value may be computed **152**. These values may be computed according to:

$$\text{STD}_{H_MEAN} = \sum_{i=0}^7 \frac{\text{STD}_H[i]}{8}$$

$$\text{STD}_{H_MAX} = \max(\text{STD}_H[i]), i = 0 \dots 7$$

$$\text{STD}_{V_MEAN} = \sum_{i=0}^7 \frac{\text{STD}_V[i]}{8}$$

$$\text{STD}_{V_MAX} = \max(\text{STD}_V[i]), i = 0 \dots 7,$$

respectively. In alternative embodiments, other statistical values may be calculated, for example, the median, the skew, the kurtosis and other statistical measures.

The computed statistics associated with the horizontal standard deviation values may be combined **154** to form an estimate of the horizontal compression noise. The computed statistics associated with the vertical standard deviation values may be combined **156** to form an estimate of the vertical

compression noise. In an exemplary embodiment of the present invention, an estimate of the horizontal compression noise may be calculated according to a weighted average given by:

$$\text{Noise}_{\text{Compression}_H} = 4.64 \cdot \text{STD}_{H_MAX} - 4.26 \cdot \text{STD}_{H_MEAN} + 0.58,$$

and an estimate of the vertical compression noise may be calculated according to a weighted average given by:

$$\text{Noise}_{\text{Compression}_V} = 4.64 \cdot \text{STD}_{V_MAX} - 4.26 \cdot \text{STD}_{V_MEAN} + 0.58,$$

where the values 4.64, 4.26 and 0.58 are exemplary weighting parameters. In alternative embodiments, other weighting values may be used.

The estimate for the horizontal compression noise and the estimate for the vertical compression noise may be combined **158** to form a single compression noise estimate. Any data fusion method known in the art may be used to combine the estimate for the horizontal compression noise and the estimate for the vertical compression noise. In some embodiments of the present invention, the compression-noise estimate may be determined according to:

$$\text{Noise}_{\text{Compression}} = \max(\text{Noise}_{\text{Compression}_H}, \text{Noise}_{\text{Compression}_V}).$$

In alternative embodiments of the present invention, the codec-noise statistic estimator **128** may calculate an estimate for the codec noise **132** according to FIG. **12**. In these embodiments, the input image may be a frame in a video sequence, and past frames may be considered in determining the noise estimate. In these embodiments, a luminance image may be computed **170** from an input RGB, or other color space, image, and the luminance may be denoted $I(x,y)$, where x and y may denote the horizontal and vertical indices, respectively. A horizontal difference value at each point may be computed **172**, thereby producing a plurality of horizontal difference values, and a vertical difference value at each point may be computed **174**, thereby producing a plurality of vertical difference values, according to:

$$D_H(x,y) = I(x+1,y) - I(x,y)$$

and

$$D_V(x,y) = I(x,y+1) - I(x,y),$$

respectively, where $D_H(x,y)$ may denote a horizontal difference value at pixel location (x,y) and $D_V(x,y)$ may denote a vertical difference value at pixel location (x,y) .

The standard deviation of the horizontal differences at a plurality of horizontal offsets may be computed **176**, and the standard deviation of the vertical differences at a plurality of vertical offsets may be computed **178**. In some embodiments of the present invention, a standard deviation value may be calculated for each offset within a coding block, thereby producing a plurality of horizontal standard deviation values and a plurality of vertical standard deviation values. The number of offsets may be determined by the structure of the video codec and any processing or scaling of the decoded data that may be performed prior to estimating the compression noise. In an exemplary embodiment comprising the use of eight offsets, the standard deviation values of the horizontal differences may be calculated **176** according to:

$$\text{Mean}_H[i] = \sum_{x=0}^{\text{Height}} \sum_{y=0}^{\frac{\text{Width}}{8}} \frac{D_H(x, 8 \cdot y + i)}{\text{Height} \cdot (\text{Width}/8)}, i = 0 \dots 7$$

$$\text{Mean2}_H[i] = \sum_{x=0}^{\text{Height}} \sum_{y=0}^{\frac{\text{Width}}{8}} \frac{D_H(x, 8 \cdot y + i)^2}{\text{Height} \cdot (\text{Width}/8)}, i = 0 \dots 7$$

$$\text{STD}_H[i] = \sqrt{\text{Mean2}_H[i] - \text{Mean}_H[i]^2}, i = 0 \dots 7.$$

The standard deviation values of the vertical differences may be similarly calculated **178** according to:

$$\text{Mean}_V[i] = \sum_{x=0}^{\frac{\text{Height}}{8}} \sum_{y=0}^{\text{Width}} \frac{D_V(8 \cdot x + i, y)}{(\text{Height}/8) \cdot \text{Width}}, i = 0 \dots 7$$

$$\text{Mean2}_V[i] = \sum_{x=0}^{\frac{\text{Height}}{8}} \sum_{y=0}^{\text{Width}} \frac{D_V(8 \cdot x + i, y)^2}{(\text{Height}/8) \cdot \text{Width}}, i = 0 \dots 7$$

$$\text{STD}_V[i] = \sqrt{\text{Mean2}_V[i] - \text{Mean}_V[i]^2}, i = 0 \dots 7.$$

Statistics may be computed **180** for the horizontal standard deviation values, and statistics may be computed **182** for the vertical standard deviation values. In some embodiments of the present invention, the average of the horizontal standard deviation values and the maximum horizontal standard deviation value may be computed **180**, and the average of the vertical standard deviation values and the maximum vertical standard deviation value may be computed **182**. These values may be computed according to:

$$\text{STD}_{H_MEAN} = \sum_{i=0}^7 \frac{\text{STD}_H[i]}{8}$$

$$\text{STD}_{H_MAX} = \max(\text{STD}_H[i]), i = 0 \dots 7$$

$$\text{STD}_{V_MEAN} = \sum_{i=0}^7 \frac{\text{STD}_V[i]}{8}$$

$$\text{STD}_{V_MAX} = \max(\text{STD}_V[i]), i = 0 \dots 7,$$

respectively. In alternative embodiments, other statistical values may be calculated, for example, the median, the skew, the kurtosis and other statistical measures.

The computed statistics associated with the horizontal standard deviation values may be combined **184** to form an estimate of the horizontal compression noise. The computed statistics associated with the vertical standard deviation values may be combined **186** to form an estimate of the vertical compression noise. In an exemplary embodiment of the present invention, an estimate of the horizontal compression noise may be calculated according to a weighted average given by:

$$\text{Noise}_{\text{Compression}_H} = 4.64 \cdot \text{STD}_{H_MAX} - 4.26 \cdot \text{STD}_{H_MEAN} + 0.58,$$

and an estimate of the vertical compression noise may be calculated according to a weighted average given by:

$$\text{Noise}_{\text{Compression}_V} = 4.64 \cdot \text{STD}_{V_MAX} - 4.26 \cdot \text{STD}_{V_MEAN} + 0.58,$$

11

where the values 4.64, 4.26 and 0.58 are exemplary weighting parameters. In alternative embodiments, other weighting values may be used.

The location of block boundaries in the current image frame may be estimated **188, 190** using the statistics previously computed. In an exemplary embodiment, a horizontal-block boundary location may be estimated **188** using the maximum horizontal standard deviation value according to:

$$\text{Block}_H[\text{frame_num}] = i, \text{ where } \text{STD}_{H_MAX} = \text{STD}_H[i],$$

where frame_num may denote a time index associated with the current frame. A vertical block-boundary location may be estimated **190** by the maximum vertical standard deviation value according to:

$$\text{Block}_V[\text{frame_num}] = i, \text{ where } \text{STD}_{V_MAX} = \text{STD}_V[i],$$

where frame_num may denote a time index associated with the current frame.

The number of unique horizontal block-boundary locations and the number of unique vertical block-boundary locations in a temporal block may be determined **192, 194** by counting the number of unique values for $\text{Block}_H[i]$ and $\text{Block}_V[i]$, respectively, where i is an index with values from frame_num to frame_num-N and N is a constant. If the number of unique values for the horizontal direction is above a threshold, then the estimate for the horizontal compression noise may be set equal to zero, and if the number of unique values for the vertical direction is above a threshold, then the estimate for the vertical compression noise may be set equal to zero.

The estimate for the horizontal compression noise and the estimate for the vertical compression noise may be combined **196** to form a single compression noise estimate. Any data fusion method known in the art may be used to combine the estimate for the horizontal compression noise and the estimate for the vertical compression noise. In some embodiments of the present invention, the compression-noise estimate may be determined according to:

$$\text{Noise}_{\text{Compression}} = \max(\text{Noise}_{\text{Compression}_H}, \text{Noise}_{\text{Compression}_V}).$$

In some embodiments of the present invention, the parameters of an edge-preserving filter may be adjusted based on a sharpening value used in a sharpening filter. In some exemplary embodiments, the edge-preserving filter may comprise a bi-lateral filter. In exemplary embodiments of the present invention shown in FIG. 13 and FIG. 14, an edge-preserving filter **204** may be used to separate an input image **200** into two channels: a first channel **206** which may comprise image content to be sharpened by un-sharp masking (USM) **212**; and a second channel **210** which may comprise image content to attenuate. The level of sharpening associated with the un-sharp masking **212** may be controlled by the value of the USM alpha **213** set for the USM filter **212**. In these embodiments, a filter parameter value **203** of the edge-preserving filter **204** may control the assignment of input-image content to the first channel **206** and the second channel **210**. In some embodiments of the present invention wherein the edge-preserving filter comprises a bi-lateral filter, the filter parameter value may be the range sigma parameter value associated with the bi-lateral filter.

In some embodiments, in order to maximize the amount of sharpening, the filter parameter **203** may be set based on the noise statistics associated with the input image **200**, and additionally, in order to mitigate noise amplification due to sharpening, the filter parameter **203** may be set based on the sharpening value **213** used in the sharpening filter **212**.

12

An input image **200** and a filter parameter value **203** associated with the input image may be made available to an edge-preserving filter **204**. The edge-preserving filter **204** may be used to divide the input image **200** into two channels **206, 210**. The first channel **206** may correspond to significant features in the input image **200**, and the second channel **210**, formed by removing **208** the first channel **206** from the input image **200**, may contain the residual difference between the first channel **206** and the input image **200**. The residual difference **210** may comprise noise and texture data. The first channel **206** may be sharpened using un-sharp masking **212**, and the second channel **210** may be attenuated **214** in accordance with noise **125**. The sharpened channel **216** and the attenuated channel **218** may be combined **220** to form an enhanced image **222**. The filter parameter value **203** of the edge-preserving filter **204** may control the assignment of input-image content to the first channel **206** and the second channel **210**. In some embodiments of the present invention (not shown), the enhanced image **222** may be up-sampled to a resolution greater than that of the input image **200**.

Referring to FIG. 14, the input image **200** may be received by a noise estimator **230** which may generate a noise estimate **231** based on an estimate of the image noise and the codec noise present in the input image **200**. The noise estimate **231** may be determined according to the previously described embodiments of the present invention. The noise estimate **231** may be adjusted by a USM sharpening compensator **232** to account for the sharpening value, and the resulting sharpening-adjusted value **233** may be temporally filtered **234** to reduce noise in the control process. The output of the temporal filter **234** may be the filter parameter value **203** provided to the edge-preserving filter **204**.

In some embodiments of the present invention described in relation to FIG. 14 and FIG. 15, the noise estimator **230** may comprise an image-noise statistic estimator **250** and a codec-noise statistic estimator **252** for estimating image noise and codec noise associated with an input image **200**, respectively. The noise estimator **230** may comprise a combiner **254** for combining the image noise estimated by the image-noise statistic estimator **250** and the codec noise codec-noise statistic estimator **252**. The noise estimate **231** may be provided to the USM sharpening compensator **232**. In some embodiments, the noise estimate **231** may be converted to a standard deviation value in the noise estimator **230**. In alternative embodiments, the noise estimate may be converted to a standard deviation value in the USM sharpening compensator **232**.

The USM sharpening compensator **232** may adjust the noise estimate **231** by a value associated with the level of sharpening **213**. In some embodiments of the present invention, a sharpening compensator controller **256** may use the USM alpha value **213** as an index into a look-up table **258** to determine a multiplier **257** which may be used to multiplicatively adjust **260** the standard-deviation-value noise estimate **231**. FIG. 16 depicts two plots **280, 282** each associated with an exemplary look-up table derived to maintain a constant noise level with increasing sharpening factor.

In addition to adjusting the noise estimate **231** by the value **257** associated with the level of sharpening **213**, the noise estimate **231** may be multiplicatively **260** adjusted by a value associated with control parameter, which may be denoted M , that controls how quickly the estimated parameter values may change as a function of time. In some embodiments the multiplicative adjustment **260** may be $1-M$. In some embodiments of the present invention, a smaller value for M may correspond to a faster change, while a larger value for M may correspond to a slower change. In some embodiments of the

present invention, M may be set to 0.5. A filter parameter value **263** associated with a previous frame may be retrieved from storage **262** and multiplied **264** by the control parameter M. The results of the two multiplications **260**, **264** may be added **266** to form the edge-preserving filter parameter **203** for the next frame.

In alternative embodiments described in relation to FIG. **17**, an edge-preserving filter parameter may be determined for filtering of a still image, or a video frame. An input image **300** may be received by a noise estimator **302** which may generate a noise estimate **303** based on an estimate of the image noise and the codec noise present in the input image **300**. The noise estimate **303** may be determined according to the previously described embodiments of the present invention. The noise estimate **303** may be adjusted by a USM sharpening compensator **304** to account for the sharpening value **305**, and the resulting sharpening-adjusted value **306** may be the filter parameter value **306** provided to the edge-preserving filter **204**.

In some embodiments of the present invention described in relation to FIG. **17** and FIG. **18**, the noise estimator **302** may comprise an image-noise statistic estimator **310** and a codec-noise statistic estimator **312** for estimating image noise and codec noise associated with an input image **300**, respectively. The noise estimator **302** may comprise a combiner **314** for combining the image noise estimated by the image-noise statistic estimator **310** and the codec noise codec-noise statistic estimator **312**. The noise estimate **303** may be provided to the USM sharpening compensator **304**. In some embodiments, the noise estimate **303** may be converted to a standard deviation value in the noise estimator **302**. In alternative embodiments, the noise estimate **303** may be converted to a standard deviation value in the USM sharpening compensator **304**.

The USM sharpening compensator **304** may adjust the noise estimate **303** by a value associated with the level of sharpening **305**. In some embodiments of the present invention, a sharpening compensator controller **316** may use the USM alpha value **305** as an index into a look-up table **318** to determine a multiplier **319** which may be used to multiplicatively adjust **320** the standard-deviation-value noise estimate **303** to produce a sharpening-adjusted edge-preserving filter parameter value **306**. FIG. **16** depicts two plots **280**, **282** each associated with an exemplary look-up table derived to maintain a constant noise level with increasing sharpening factor.

The effectiveness of embodiments of the present invention may be illustrated in FIGS. **19-25**. FIG. **19** depicts an exemplary, original, synthetic noise target **350**. FIG. **20** shows the result **352** of bi-lateral filtering, using a sigma range parameter value equal to the standard deviation of the noise, of the original image **250** shown in FIG. **19**. An enhanced image **354** is shown in FIG. **21**. This enhanced image **354** exhibits significant amplification of the image noise. FIG. **22** depicts an enhanced image **356** enhanced according to embodiments of the present invention in which the bi-lateral filter sigma range parameter is set according to the noise statistics of the image in addition to accounting for the sharpening strength of the sharpening filter. The noise in FIG. **22** is similar to the noise in FIG. **20**, but the degree of enhancement is different.

A second exemplary, original image **360** is depicted in FIG. **23**. A superimposed, white circle **361** is shown on the image **360** in a region wherein the noise in the image **360** is visible. FIG. **24** depicts an image **362** which results from bi-lateral filtering according to embodiments of the present invention with a range sigma parameter that has been set accounting for the noise, but not the sharpening process. Inspection of the region inside the overlaid white circle **363** shows that the

noise is amplified relative to the input image **360**. FIG. **25** depicts an image **364** which results from bi-lateral filtering according to embodiments of the present invention with a range sigma parameter that has been set accounting for both noise and the sharpening process. Inspection of the region inside the overlaid white circle **365** shows that the noise is not amplified relative to the original image **360**, but the desired increase in sharpening of image content is visible.

Some embodiments of the present invention described herein comprise an edge-preserving filter. In some embodiments, the edge-preserving filter may comprise a bi-lateral filter. A person of ordinary skill in the art will recognize the existence of many edge-preserving filters and many forms of bi-lateral filters.

Although the charts and diagrams in FIGS. **1**, **2**, **9**, **10**, **12-15**, **17** and **18** may show a specific order of execution, it is understood that the order of execution may differ from that which is depicted. For example, the order of execution of the blocks may be changed relative to the shown order. Also, as a further example, two or more blocks shown in succession in the figure may be executed concurrently, or with partial concurrence. It is understood by those with ordinary skill in the art that software, hardware and/or firmware may be created by one of ordinary skill in the art to carry out the various logical functions described herein.

Some embodiments of the present invention may comprise a computer program product comprising a computer-readable storage medium having instructions stored thereon/in which may be used to program a computing system to perform any of the features and methods described herein. Exemplary computer-readable storage media may include, but are not limited to, flash memory devices, disk storage media, for example, floppy disks, optical disks, magneto-optical disks, Digital Versatile Discs (DVDs), Compact Discs (CDs), micro-drives and other disk storage media, Read-Only Memory (ROMs), Programmable Read-Only Memory (PROMs), Erasable Programmable Read-Only Memory (EPROMs), Electrically Erasable Programmable Read-Only Memory (EEPROMs), Random-Access Memory (RAMs), Video Random-Access Memory (VRAMs), Dynamic Random-Access Memory (DRAMs) and any type of media or device suitable for storing instructions and/or data.

The terms and expressions which have been employed in the foregoing specification are used therein as terms of description and not of limitation, and there is no intention in the use of such terms and expressions of excluding equivalence of the features shown and described or portions thereof, it being recognized that the scope of the invention is defined and limited only by the claims which follow.

What is claimed is:

1. A method for estimating compression noise in an image, said method comprising:

- a) receiving an image in a noise-estimation system;
- b) computing a horizontal difference value for each pixel in a first plurality of pixels in said image, thereby producing a plurality of horizontal difference values;
- c) computing a vertical difference value for each pixel in a second plurality of pixels in said image, thereby producing a plurality of vertical difference values;
- d) computing a plurality of horizontal standard deviation values, wherein each of said horizontal standard deviation values in said plurality of horizontal standard deviation values is associated with a horizontal offset within said image;
- e) computing a plurality of vertical standard deviation values, wherein each of said vertical standard deviation

15

- values in said plurality of vertical standard deviation values is associated with a vertical offset within said image;
- f) computing a first horizontal statistic using said plurality of horizontal standard deviation values;
- g) computing a second horizontal statistic using said plurality of horizontal standard deviation values;
- h) computing a first vertical statistic using said plurality of vertical standard deviation values;
- i) computing a second vertical statistic using said plurality of vertical standard deviation values;
- j) combining said first horizontal statistic and said second horizontal statistic to form an estimate of horizontal compression noise;
- k) combining said first vertical statistic and said second vertical statistic to form an estimate of vertical compression noise; and
- l) combining said estimate of horizontal compression noise and said estimate of vertical compression noise to form a compression noise estimate.
2. The method as described in claim 1, wherein said horizontal offset and said vertical offset are related to a coding block offset associated with a codec associated with said image.
3. The method as described in claim 1, wherein:
said first horizontal statistic is a mean of said horizontal standard deviation values; and
said first vertical statistic is a mean of said vertical standard deviation values.
4. The method as described in claim 1, wherein:
said second horizontal statistic is a maximum of said horizontal standard deviation values; and
said second vertical statistic is a maximum of said vertical standard deviation values.
5. The method as described in claim 4, wherein:
said first horizontal statistic is a mean of said horizontal standard deviation values; and
said first vertical statistic is a mean of said vertical standard deviation values.
6. The method as described in claim 1, wherein said combining said first horizontal statistic and said second horizontal statistic comprises computing a weighted average of said first horizontal statistic and said second horizontal statistic.
7. The method as described in claim 1, wherein said combining said first vertical statistic and said second vertical statistic comprises computing a weighted average of said first vertical statistic and said second vertical statistic.
8. The method as described in claim 1, wherein said combining said estimate of horizontal compression noise and said estimate of vertical compression noise comprises determining the maximum value of said estimate of horizontal compression noise and said estimate of vertical compression noise.
9. The method as described in claim 1, wherein said image is a first frame in a video sequence and further comprising:
estimating a horizontal block-boundary location associated with each frame in a plurality of frames in said video sequence, wherein said first frame is in said plurality of frames, thereby producing a plurality of horizontal block-boundary locations;
estimating a vertical block-boundary location associated with each frame in said plurality of frames in said video sequence, thereby producing a plurality of vertical block-boundary locations;
determining a number of unique horizontal block-boundary locations in said plurality of horizontal block-boundary locations;

16

- determining a number of unique vertical block-boundary locations in said plurality of vertical block-boundary locations;
- comparing said number of unique horizontal block-boundary locations in said plurality of horizontal block-boundary locations to a horizontal threshold;
- comparing said number of unique vertical block-boundary locations in said plurality of vertical block-boundary locations to a vertical threshold;
- setting said estimate of horizontal compression noise to zero when said number of unique horizontal block-boundary locations in said plurality of horizontal block-boundary locations and said horizontal threshold meet a horizontal criterion; and
- setting said estimate of vertical compression noise to zero when said number of unique vertical block-boundary locations in said plurality of vertical block-boundary locations and said vertical threshold meet a vertical criterion.
10. The method as described in claim 1, wherein said receiving said image comprises:
receiving a bitstream associated with said image; and
decoding said bitstream.
11. The method as described in claim 1 further comprising making said compression noise estimate available to an edge-preserving filter, wherein a parameter value associated with said edge-preserving filter is based on said compression noise estimate.
12. The method as described in claim 11, wherein:
said edge-preserving filter is a bi-lateral filter; and
said parameter value is a value for a range sigma parameter associated with said bi-lateral filter.
13. The method as described in claim 1 further comprising combining said compression noise estimate with a second noise estimate associated with said image.
14. The method as described in claim 13, wherein said combining said compression noise estimate with said second noise estimate comprises determining the maximum value of said compression noise estimate and said second noise estimate.
15. The method as described in claim 13 further comprising making said combined noise estimate available to an edge-preserving filter, wherein a parameter value associated with said edge-preserving filter is based on said combined noise estimate.
16. The method as described in claim 15, wherein:
said edge-preserving filter is a bi-lateral filter; and
said parameter value is a value for a range sigma parameter associated with said bi-lateral filter.
17. The method as described in claim 15, wherein said parameter value associated with said edge-preserving filter is proportional to said combined noise estimate.
18. The method as described in claim 1 further comprising compensating said compression noise estimate based on a level of sharpening associated with an image enhancement system.
19. The method as described in claim 18 further comprising making said compensated compression noise estimate available to an edge-preserving filter, wherein a parameter value associated with said edge-preserving filter is based on said compensated compression noise estimate.
20. The method as described in claim 19, wherein said edge-preserving filter is a bi-lateral filter.
21. The method as described in claim 18 further comprising temporally filtering said compensated compression noise estimate.

17

22. The method as described in claim 21 further comprising making said temporally filtered compensated compression noise estimate available to an edge-preserving filter, wherein a parameter value associated with said edge-preserving filter is based on said temporally filtered compensated compression noise estimate. 5

23. The method as described in claim 22, wherein: said edge-preserving filter is a bi-lateral filter; and said parameter value is a value for a range sigma parameter associated with said bi-lateral filter. 10

24. An apparatus for estimating compression noise in an image, said apparatus comprising:

- a) an image receiver for receiving an image in a noise-estimation system;
- b) a horizontal-difference calculator for computing a horizontal difference value for each pixel in a first plurality of pixels in said image, thereby producing a plurality of horizontal difference values; 15
- c) a vertical-difference calculator for computing a vertical difference value for each pixel in a second plurality of pixels in said image, thereby producing a plurality of vertical difference values; 20
- d) a horizontal-standard-deviation calculator for computing a plurality of horizontal standard deviation values, wherein each of said horizontal standard deviation values in said plurality of horizontal standard deviation values is associated with a horizontal offset within said image; 25
- e) a vertical-standard-deviation calculator for computing a plurality of vertical standard deviation values, wherein each of said vertical standard deviation values in said plurality of vertical standard deviation values is associated with a vertical offset within said image; 30
- f) a first horizontal-statistic calculator for computing a first horizontal statistic using said plurality of horizontal standard deviation values; 35
- g) a second horizontal-statistic calculator for computing a second horizontal statistic using said plurality of horizontal standard deviation values;
- h) a first vertical-statistic calculator for computing a first vertical statistic using said plurality of vertical standard deviation values; 40
- i) a second vertical-statistic calculator for computing a second vertical statistic using said plurality of vertical standard deviation values; 45
- j) a horizontal-statistics combiner for combining said first horizontal statistic and said second horizontal statistic to form an estimate of horizontal compression noise;

18

k) a vertical-statistics combiner for combining said first vertical statistic and said second vertical statistic to form an estimate of vertical compression noise; and

l) a compression-noise combiner for combining said estimate of horizontal compression noise and said estimate of vertical compression noise to form a compression noise estimate.

25. The apparatus as described in claim 24, wherein said image is a first frame in a video sequence and further comprising:

a horizontal-block-boundary estimator for estimating a horizontal block-boundary location associated with each frame in a plurality of frames in said video sequence, wherein said first frame is in said plurality of frames, thereby producing a plurality of horizontal block-boundary locations;

a vertical-block-boundary estimator for estimating a vertical block-boundary location associated with each frame in said plurality of frames in said video sequence, thereby producing a plurality of vertical block-boundary locations;

a horizontal-block-boundary locator for determining a number of unique horizontal block-boundary locations in said plurality of horizontal block-boundary locations;

a vertical-block-boundary locator for determining a number of unique vertical block-boundary locations in said plurality of vertical block-boundary locations;

a first comparator for comparing said number of unique horizontal block-boundary locations in said plurality of horizontal block-boundary locations to a horizontal threshold;

a second comparator for comparing said number of unique vertical block-boundary locations in said plurality of vertical block-boundary locations to a vertical threshold;

a horizontal-noise-selector for setting said estimate of horizontal compression noise to zero when said number of unique horizontal block-boundary locations in said plurality of horizontal block-boundary locations and said horizontal threshold meet a horizontal criterion; and

a vertical-noise-selector for setting said estimate of vertical compression noise to zero when said number of unique vertical block-boundary locations in said plurality of vertical block-boundary locations and said vertical threshold meet a vertical criterion.

* * * * *