

US008576147B2

(12) **United States Patent**
Koyama et al.

(10) **Patent No.:** **US 8,576,147 B2**
(45) **Date of Patent:** **Nov. 5, 2013**

(54) **DISPLAY DEVICE AND ELECTRONIC DEVICE**

5,247,190 A 9/1993 Friend et al.
5,325,108 A 6/1994 Salam
5,399,502 A 3/1995 Friend et al.
5,594,463 A 1/1997 Sakamoto
5,597,223 A 1/1997 Watanabe et al.

(75) Inventors: **Jun Koyama**, Kanagawa (JP); **Shunpei Yamazaki**, Tokyo (JP)

(Continued)

(73) Assignee: **Semiconductor Energy Laboratory Co., Ltd.**, Atsugi-shi, Kanagawa-ken (JP)

FOREIGN PATENT DOCUMENTS

CN 1329368 A 1/2002
EP 0923067 A1 6/1999

(*) Notice: Subject to any disclaimer, the term of this patent is extended or adjusted under 35 U.S.C. 154(b) by 0 days.

(Continued)

OTHER PUBLICATIONS

(21) Appl. No.: **13/484,489**

Hermann Schenk et al.; "Polymers for Light Emitting Diodes"; EuroDisplay '99; pp. 33-37; 1999.

(22) Filed: **May 31, 2012**

(65) **Prior Publication Data**

US 2012/0306728 A1 Dec. 6, 2012

(Continued)

Related U.S. Application Data

(63) Continuation of application No. 11/201,375, filed on Aug. 11, 2005, now Pat. No. 8,194,006.

Primary Examiner — Rodney Amadiz

(74) Attorney, Agent, or Firm — Fish & Richardson P.C.

(30) **Foreign Application Priority Data**

Aug. 23, 2004 (JP) 2004-242820

(57) **ABSTRACT**

(51) **Int. Cl.**
G09G 3/30 (2006.01)

(52) **U.S. Cl.**
USPC **345/76**

(58) **Field of Classification Search**
USPC 345/76-86, 204, 212, 690;
315/168-169.3, 307; 324/760.01
See application file for complete search history.

A display device suppresses the influence of variations of a current value supplied to a light emitting element caused by a temperature change. In particular, luminance variations caused by a temperature gradient in a pixel portion due to a heat generated from a source signal line driver circuit are suppressed. In a display device including a gate signal line provided in a row direction, a source signal line provided in a column direction, and a light emitting element in a pixel portion arranged in matrix corresponding to the gate signal line and the source signal line, a column of monitor elements is provided beside the pixel portion, a constant current is supplied to each row of the monitor elements, and a voltage generated at the monitor element for each row of pixels is applied to light emitting elements of the corresponding row.

(56) **References Cited**

U.S. PATENT DOCUMENTS

4,308,556 A 12/1981 Osaka
5,033,023 A 7/1991 Hsia et al.

12 Claims, 26 Drawing Sheets

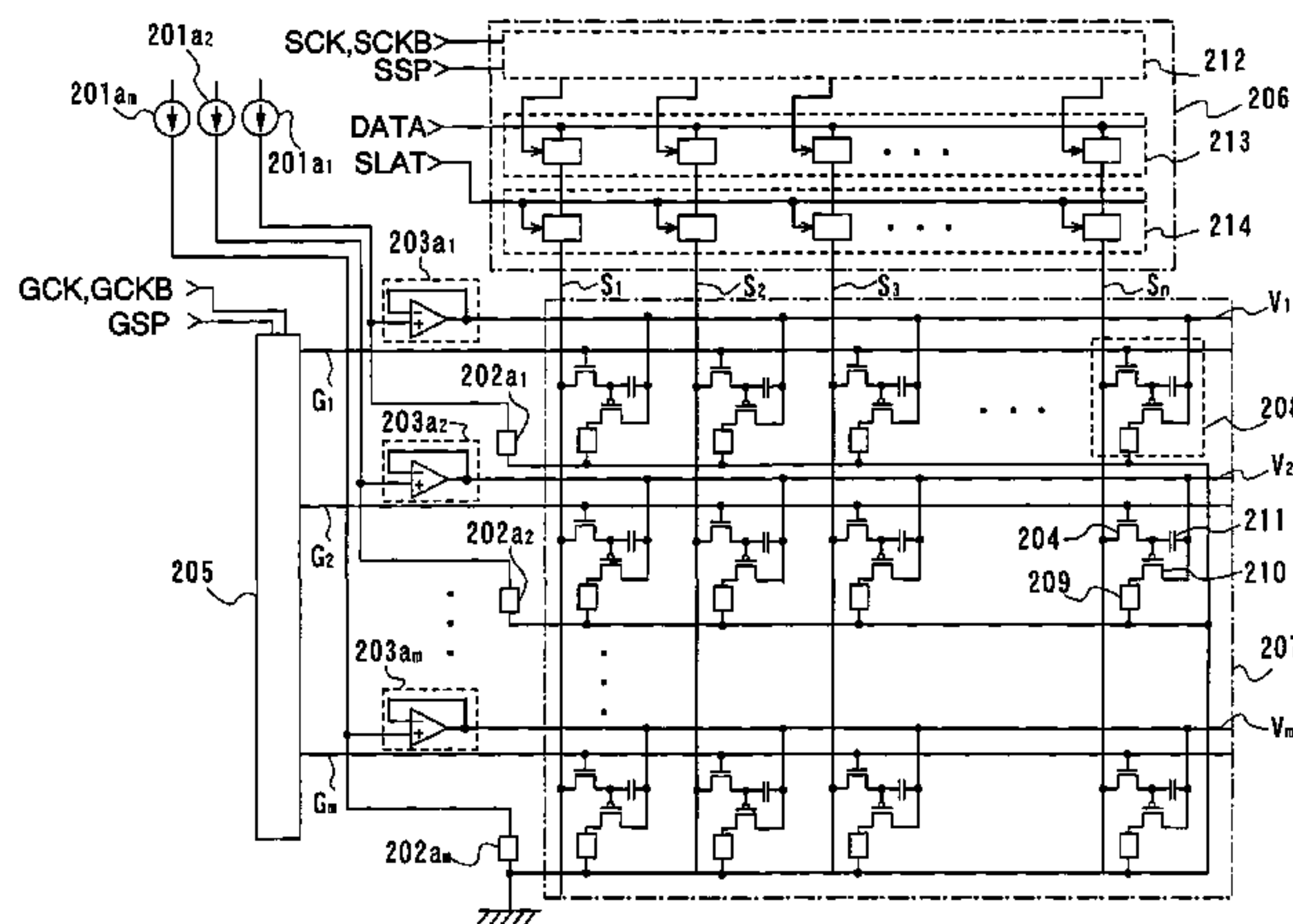

(56)

References Cited

U.S. PATENT DOCUMENTS

5,745,085 A 4/1998 Tomio et al.
 5,844,535 A 12/1998 Itoh et al.
 5,882,761 A 3/1999 Kawami et al.
 5,886,474 A 3/1999 Asai et al.
 5,893,730 A 4/1999 Yamazaki et al.
 5,990,629 A 11/1999 Yamada et al.
 6,005,350 A 12/1999 Hachiya et al.
 6,049,321 A 4/2000 Sasaki
 6,054,976 A 4/2000 Kubota et al.
 6,069,676 A 5/2000 Yuyama
 6,072,448 A 6/2000 Kojima et al.
 6,097,302 A 8/2000 Zinzell
 6,147,451 A 11/2000 Shibata et al.
 6,219,113 B1 4/2001 Takahara
 6,320,325 B1 11/2001 Cok et al.
 6,335,713 B1 1/2002 Imai
 6,373,459 B1 4/2002 Jeong
 6,376,994 B1 4/2002 Ochi et al.
 6,380,558 B1 4/2002 Yamazaki et al.
 6,392,617 B1 5/2002 Gleason
 6,396,468 B2 5/2002 Matsushima et al.
 6,396,508 B1 5/2002 Noecker
 6,404,137 B1 6/2002 Shodo
 6,411,306 B1 6/2002 Miller et al.
 6,414,443 B2 7/2002 Tsuruoka et al.
 6,414,661 B1 7/2002 Shen et al.
 6,417,824 B1 7/2002 Tokunaga et al.
 6,424,326 B2 7/2002 Yamazaki et al.
 6,452,576 B1 9/2002 Van et al.
 6,486,862 B1 11/2002 Jacobsen et al.
 6,496,218 B2 12/2002 Takigawa et al.
 6,518,941 B1 2/2003 Kimura
 6,518,962 B2 2/2003 Kimura et al.
 6,525,704 B1 2/2003 Kondo et al.
 6,528,951 B2 3/2003 Yamazaki et al.
 6,534,925 B2 3/2003 Kawashima
 6,552,736 B2 4/2003 Honda et al.
 6,680,577 B1 1/2004 Inukai et al.
 6,788,003 B2 9/2004 Inukai et al.
 6,816,144 B2 11/2004 Tsuchi
 6,828,950 B2 12/2004 Koyama
 7,061,186 B2 6/2006 Inukai et al.
 7,180,515 B2 2/2007 Miyagawa et al.
 7,215,307 B2 5/2007 Ochi et al.
 7,218,297 B2 5/2007 Inukai et al.
 7,245,297 B2 7/2007 Kimura et al.
 7,298,347 B2 11/2007 Yamazaki et al.
 7,453,453 B2 11/2008 Miyagawa et al.
 7,589,698 B2 9/2009 Osame et al.
 7,609,236 B2 10/2009 Koyama
 7,635,863 B2 12/2009 Yamazaki et al.
 7,773,082 B2 8/2010 Miyagawa et al.
 7,999,769 B2 8/2011 Miyagawa et al.
 8,284,127 B2 10/2012 Koyama
 2001/0017618 A1 8/2001 Azami
 2001/0026257 A1 10/2001 Kimura
 2001/0033252 A1 10/2001 Yamazaki et al.
 2002/0005696 A1 1/2002 Yamazaki et al.
 2002/0053884 A1 5/2002 Kimura
 2002/0145602 A1 10/2002 Matsueda
 2002/0154151 A1 10/2002 Koyama

2002/0167381 A1 11/2002 Ide et al.
 2002/0180672 A1 12/2002 Yamazaki et al.
 2002/0180721 A1 12/2002 Kimura et al.
 2003/0063081 A1 4/2003 Kimura et al.
 2003/0132716 A1 7/2003 Yamazaki et al.
 2003/0209989 A1 11/2003 Anzai et al.
 2004/0051684 A1* 3/2004 Ishizuka 345/76
 2004/0130545 A1* 7/2004 Ishizuka 345/212
 2005/0012731 A1 1/2005 Yamazaki et al.
 2005/0017933 A1 1/2005 Koyama
 2005/0017963 A1 1/2005 Yamazaki et al.
 2005/0017964 A1 1/2005 Yamazaki et al.
 2005/0219167 A1 10/2005 Hattori et al.
 2006/0038804 A1 2/2006 Hayakawa et al.
 2006/0139254 A1 6/2006 Hayakawa et al.
 2007/0182675 A1 8/2007 Yamazaki et al.

FOREIGN PATENT DOCUMENTS

EP 1103947 A2 5/2001
 EP 1168291 A2 1/2002
 EP 1227467 A2 7/2002
 EP 1 355 289 A2 10/2003
 EP 2256718 A2 12/2010
 JP 05-094151 A 4/1993
 JP 07-036410 A 2/1995
 JP 09-148066 A 6/1997
 JP 10-092576 A 4/1998
 JP 10-214060 A 8/1998
 JP 10-232649 A 9/1998
 JP 11-272223 A 10/1999
 JP 11-273856 A 10/1999
 JP 2001-109433 A 4/2001
 JP 2001-222240 A 8/2001
 JP 2001-223074 A 8/2001
 JP 2001-236040 A 8/2001
 JP 2002-072964 A 3/2002
 JP 2002-123219 A 4/2002
 JP 2002-175046 A 6/2002
 JP 2002-304155 A 10/2002
 JP 2002-351403 A 12/2002
 JP 2003-323159 A 11/2003
 JP 2004-004759 A 1/2004
 JP 2004-170943 A 6/2004
 JP 2004-205704 A 7/2004
 JP 2004-226737 A 8/2004
 JP 2004-279824 A 10/2004
 TW 250560 A 7/1995
 WO WO 90/13148 A1 11/1990
 WO WO 98/40871 A1 9/1998
 WO WO 01/27910 A1 4/2001
 WO WO 2004/040541 A1 5/2004

OTHER PUBLICATIONS

Mayumi Mizukami et al.; "6-Bit Digital VGA OLED"; SID 00 Digest; pp. 912-915; 2000.
 R.M.A. Dawson et al.; "Design of an Improved Pixel for a Polysilicon Active-Matrix Organic LED Display"; SID 98 Digest; pp. 11-14; 1998.
 Office Action (U.S. Appl. No. 09/833,673) dated Dec. 1, 2004.
 Chinese Office Action for Application No. 200510092492.2; dated Mar. 6, 2009 with English translation, 22 pages.

* cited by examiner

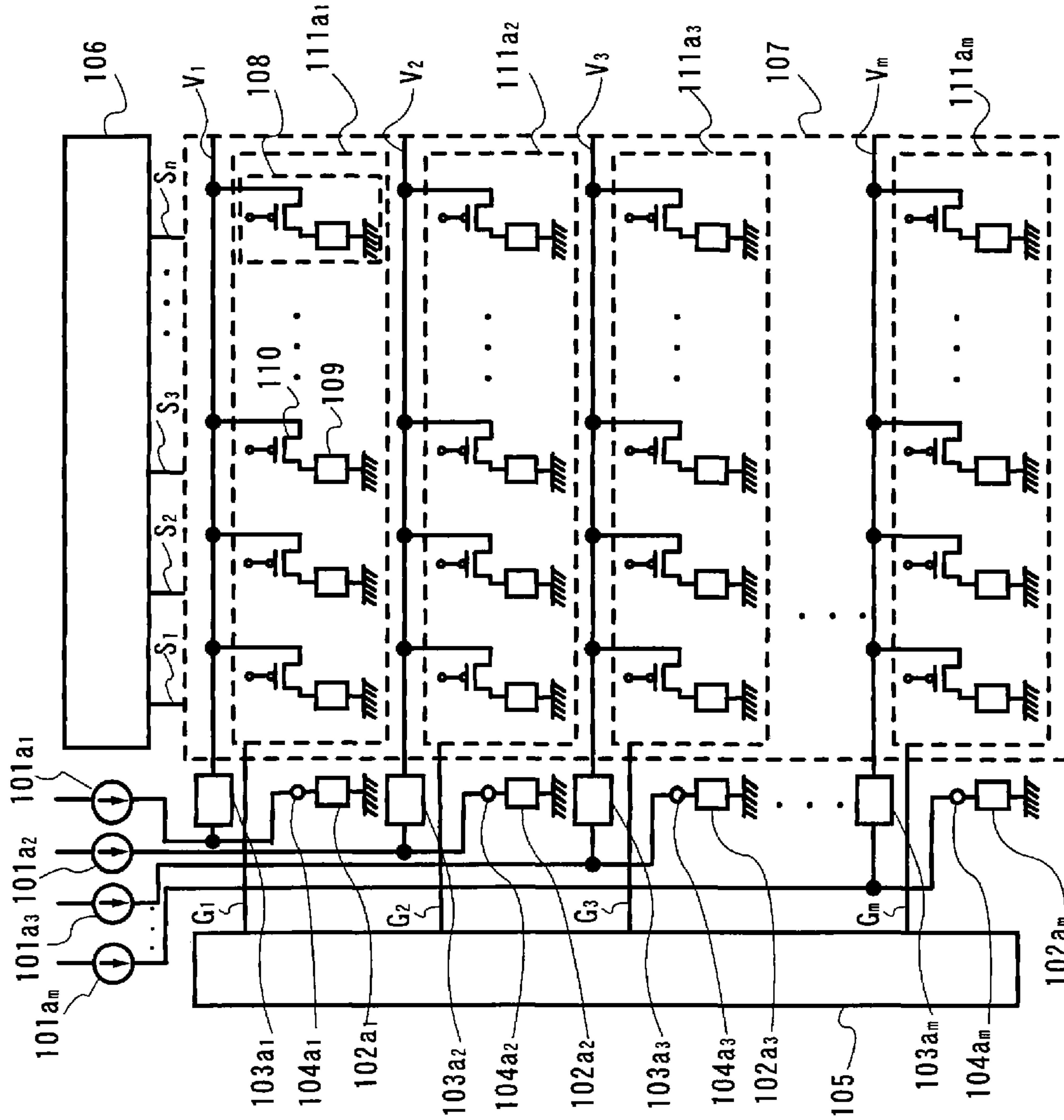

FIG. 1

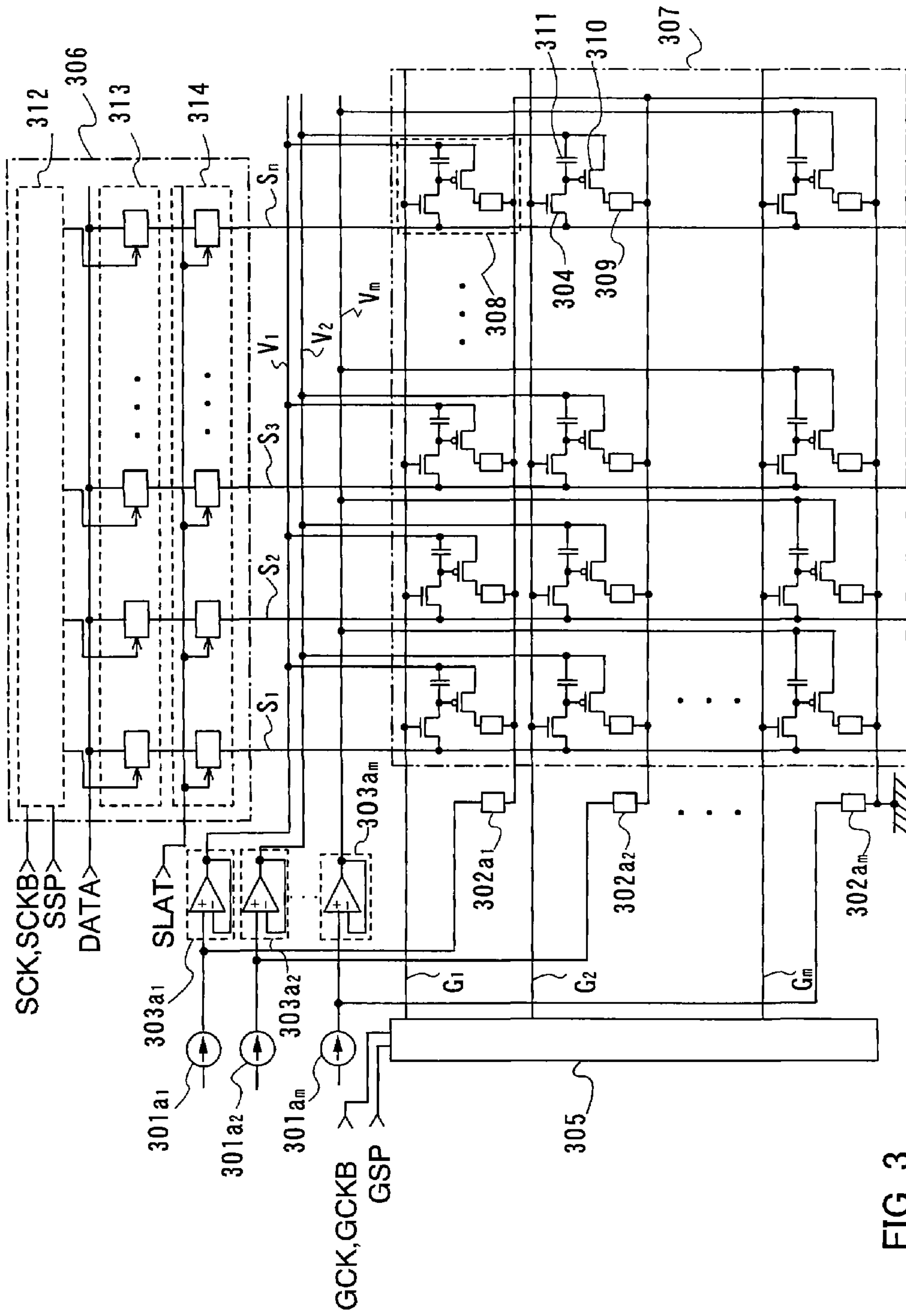

FIG. 3

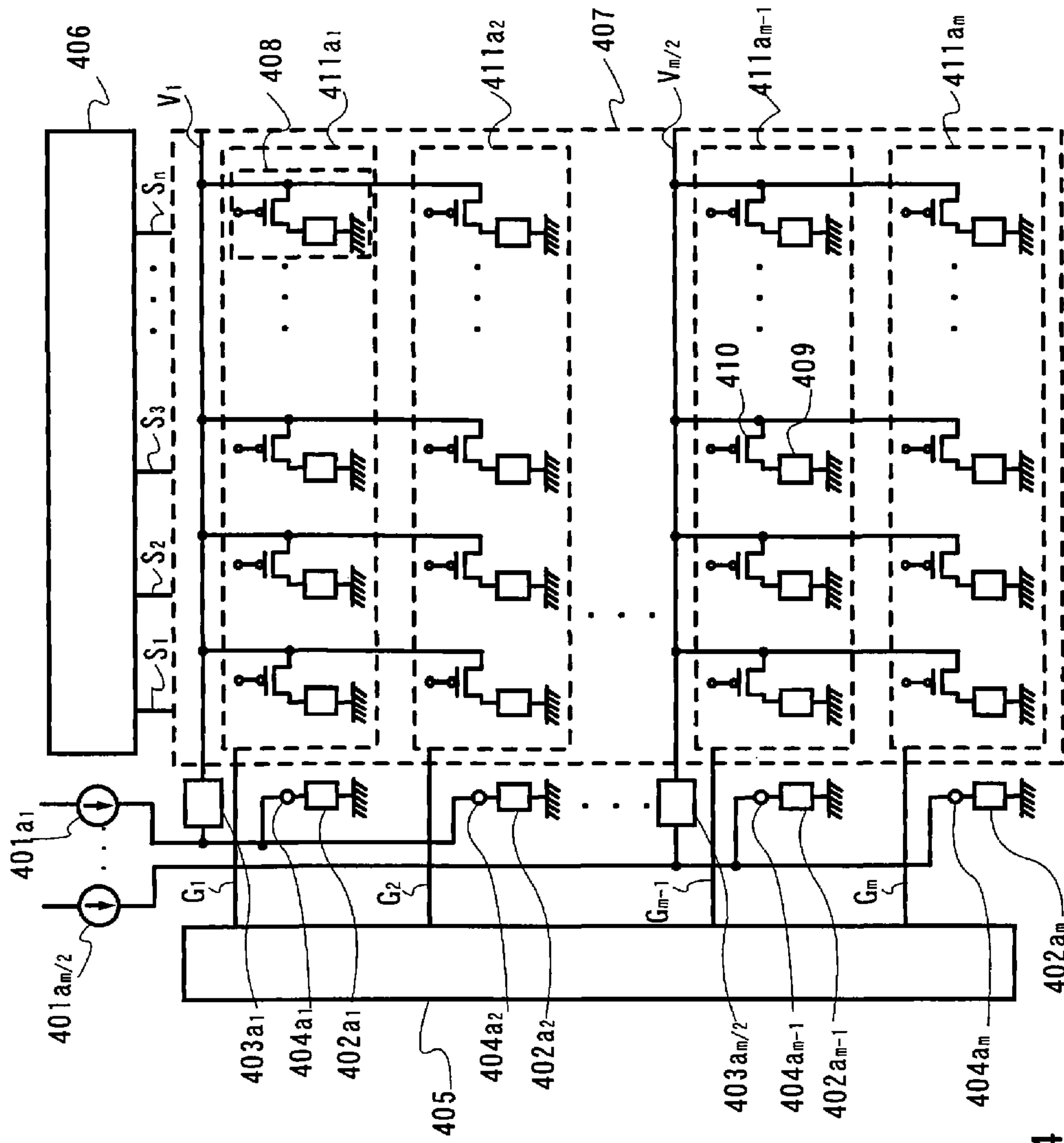

FIG. 4

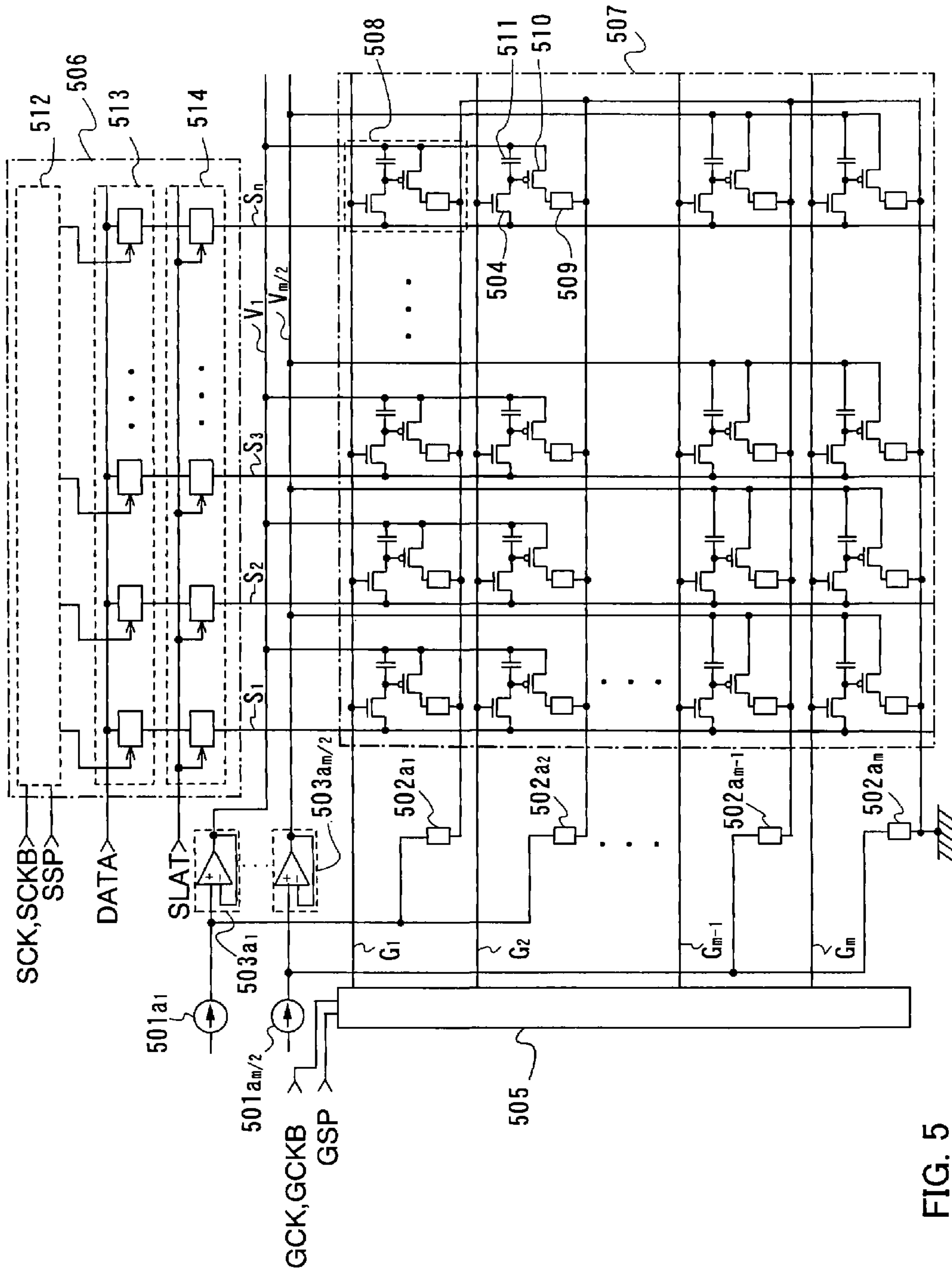

FIG. 5

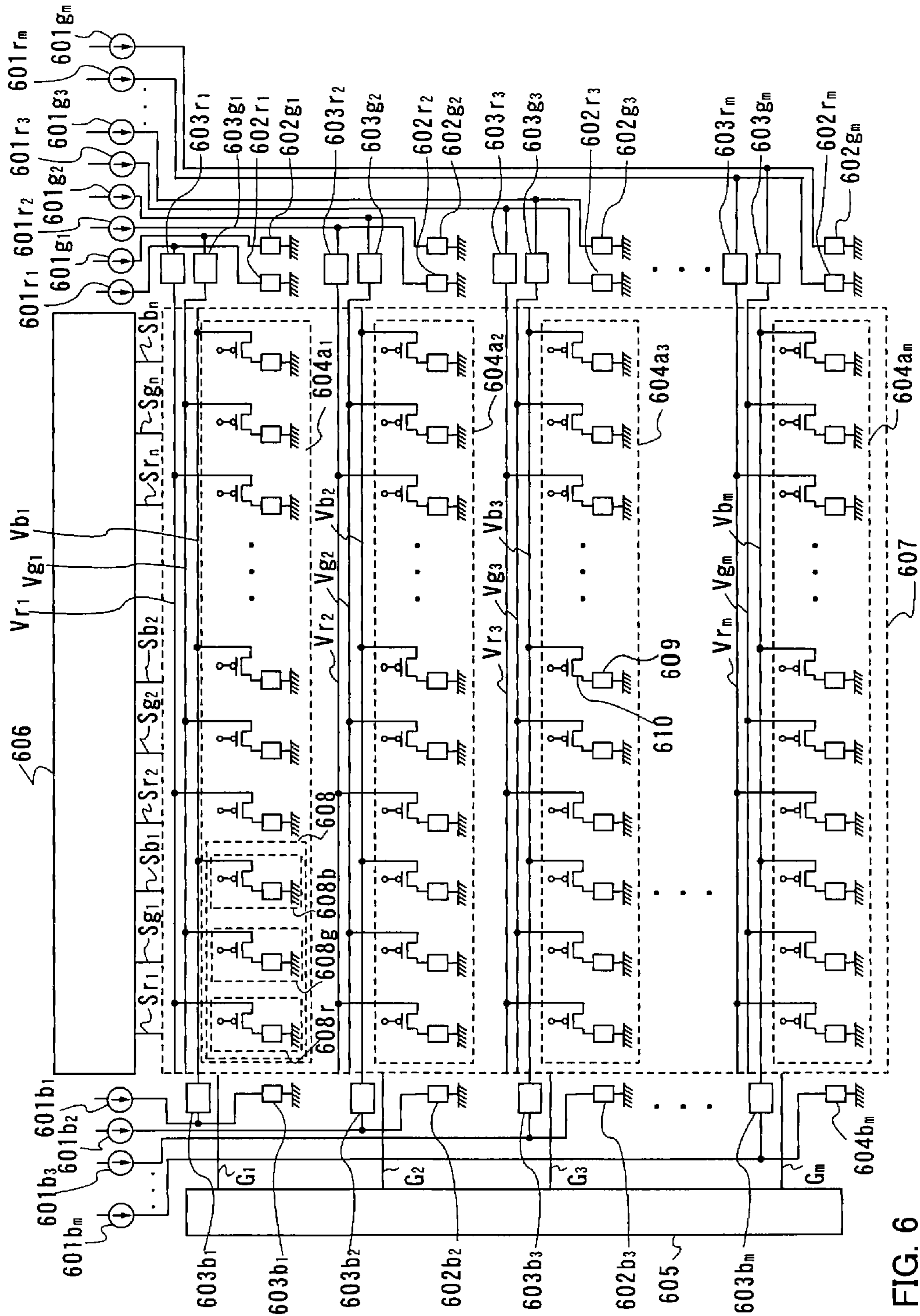

FIG. 6

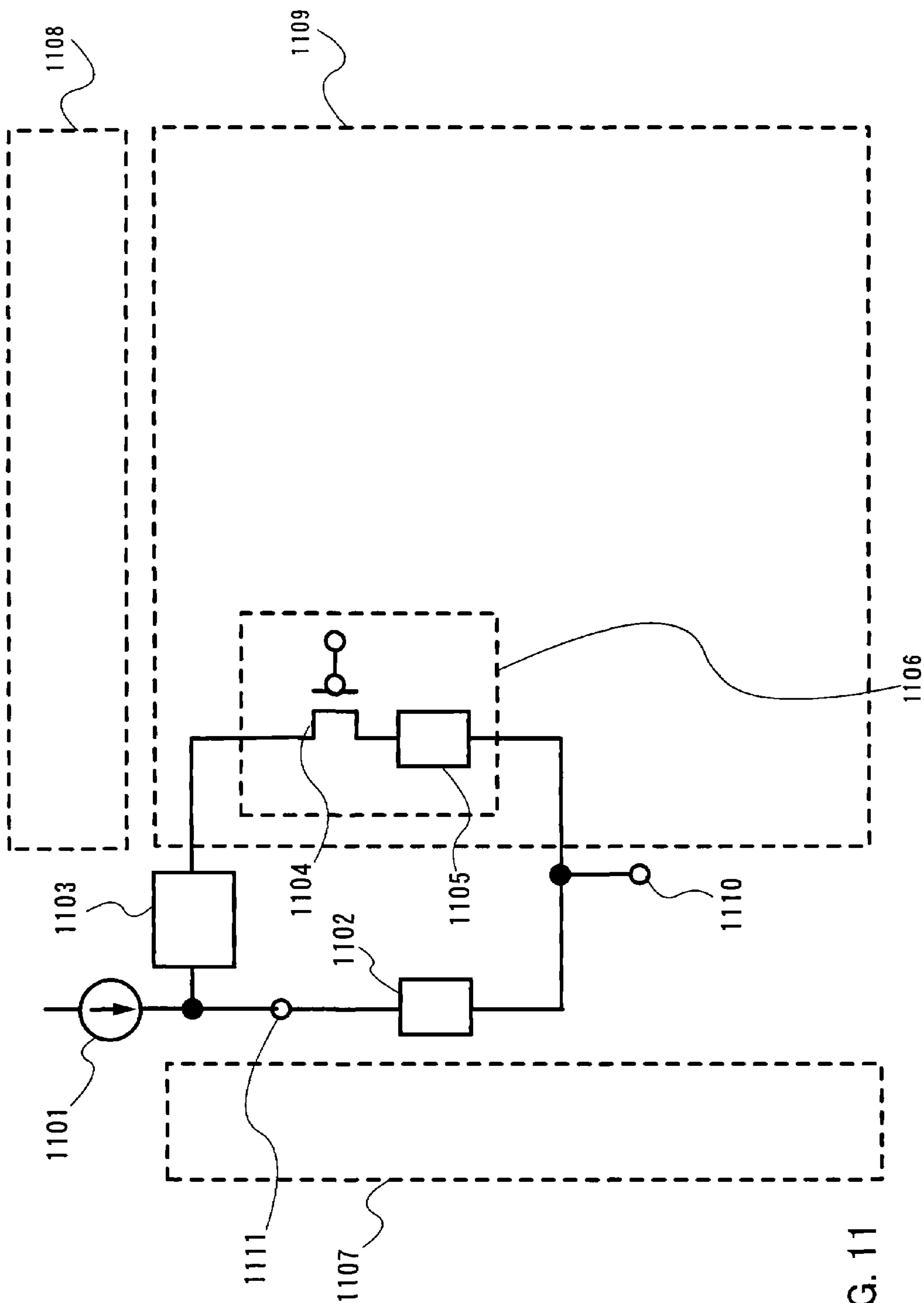

FIG. 11

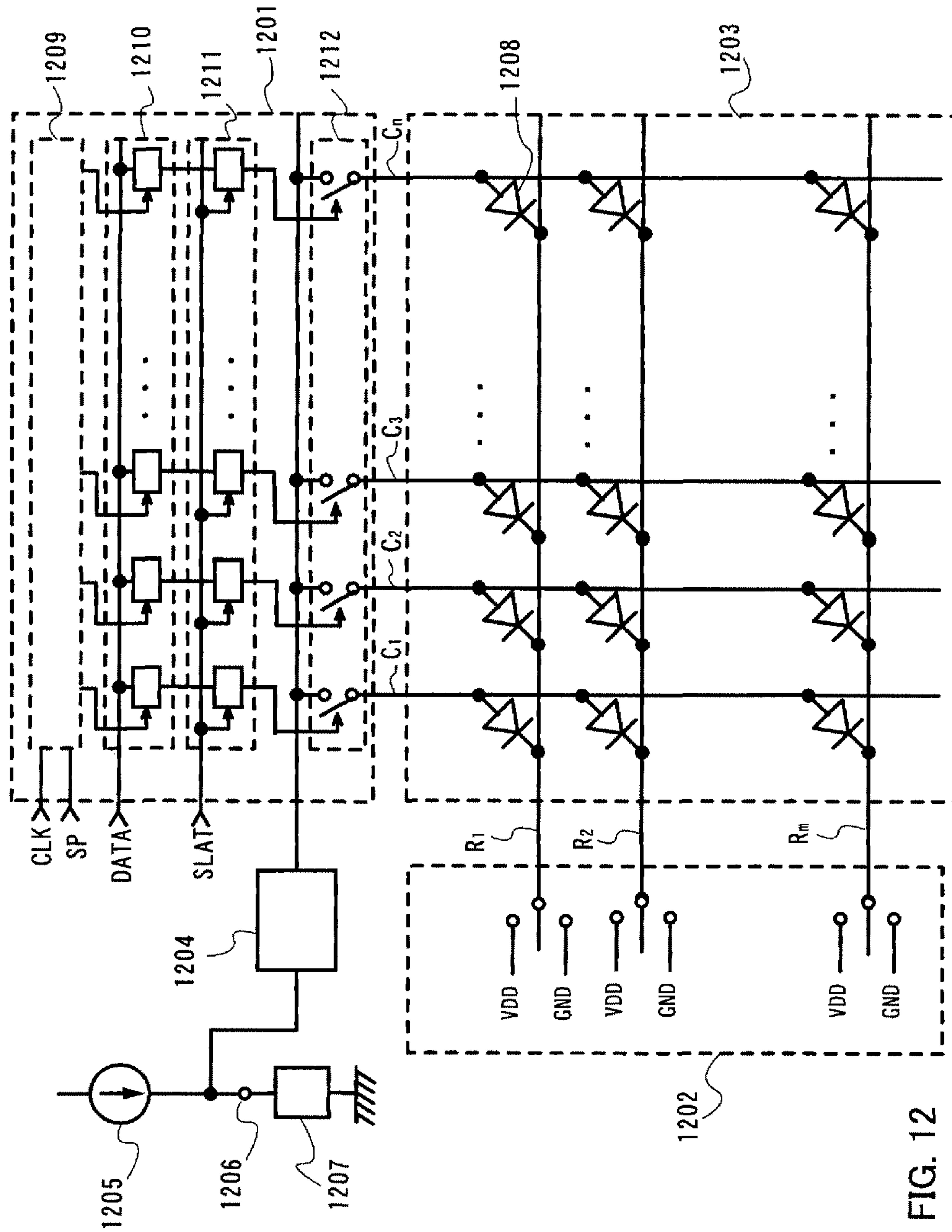

FIG. 12

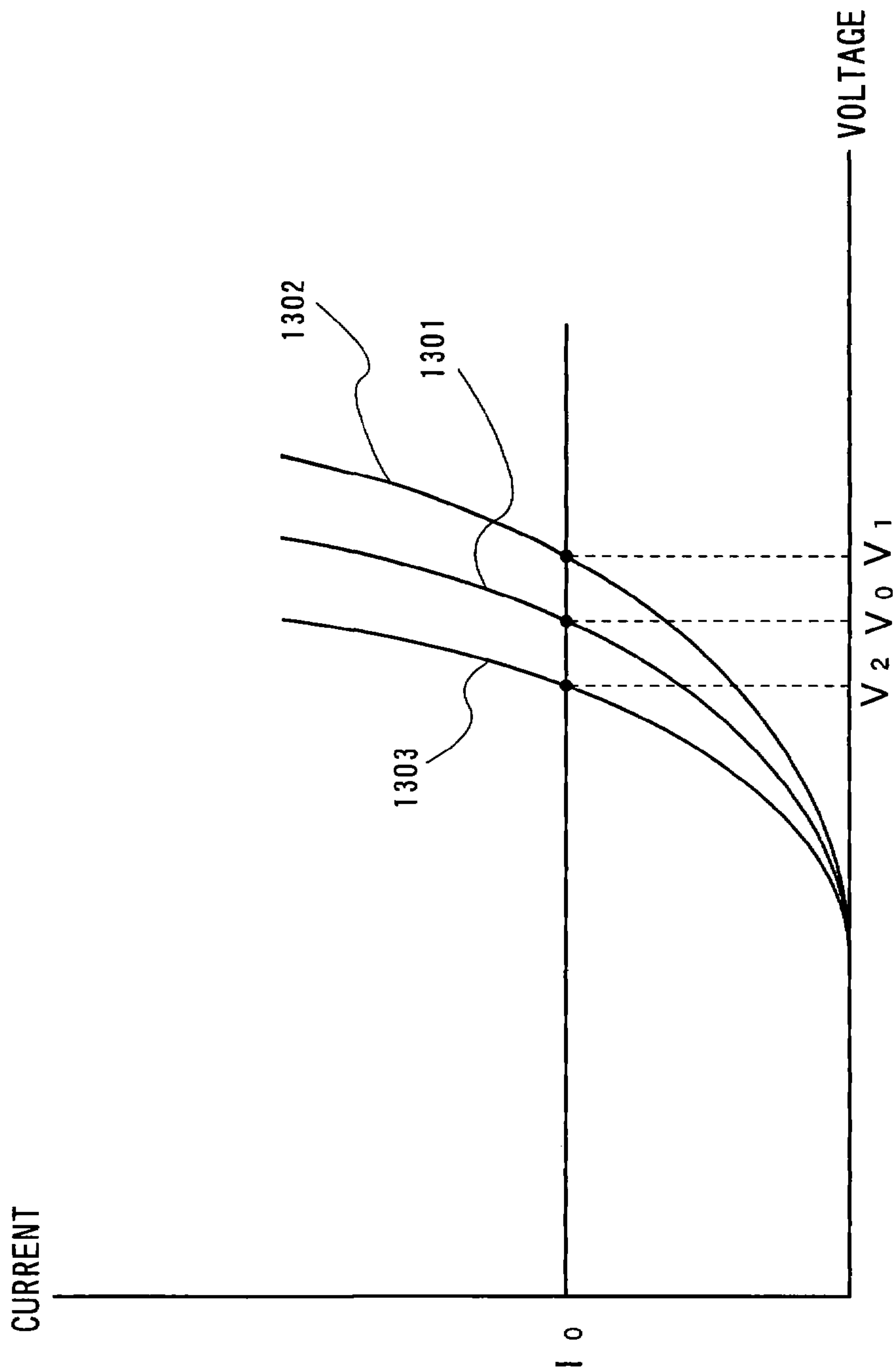

FIG. 13

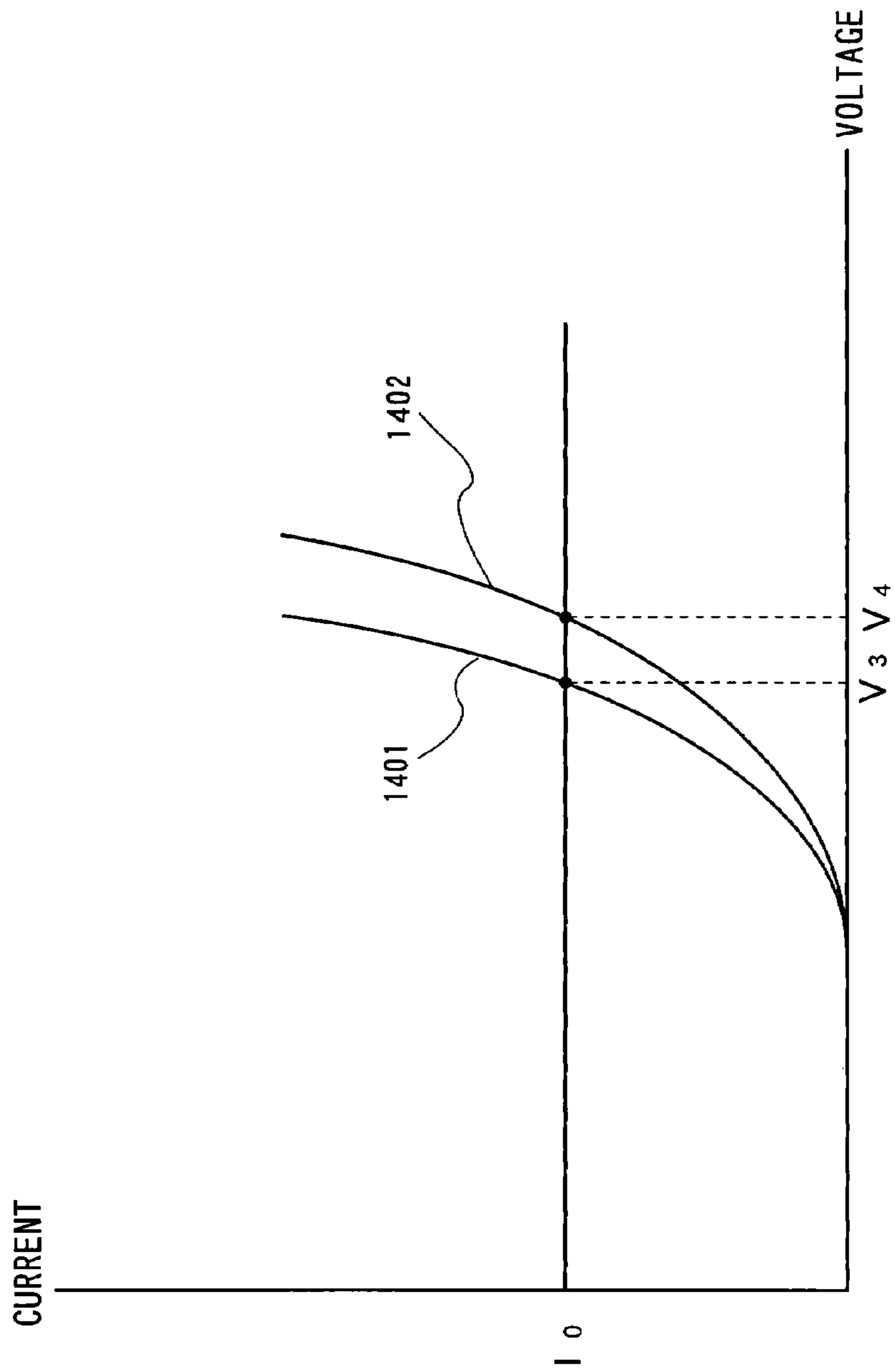

FIG. 14

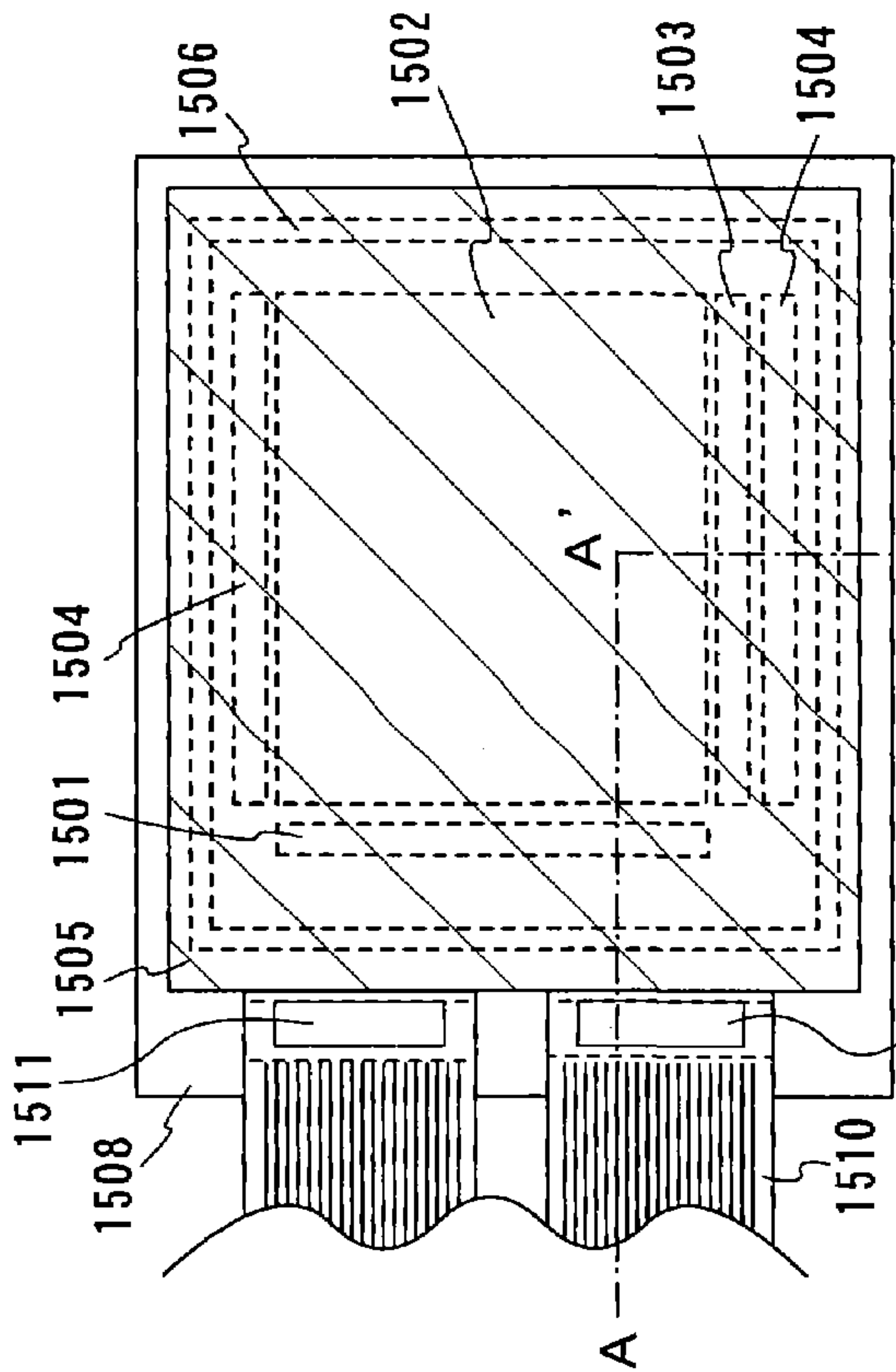

FIG. 15A

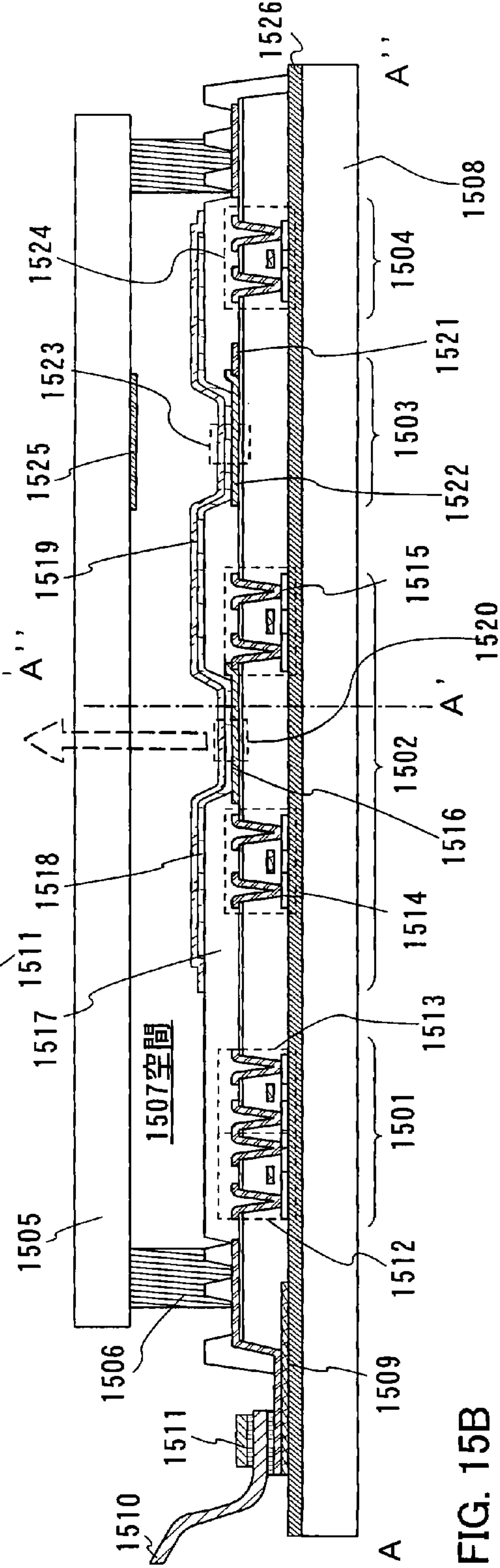

FIG. 15B

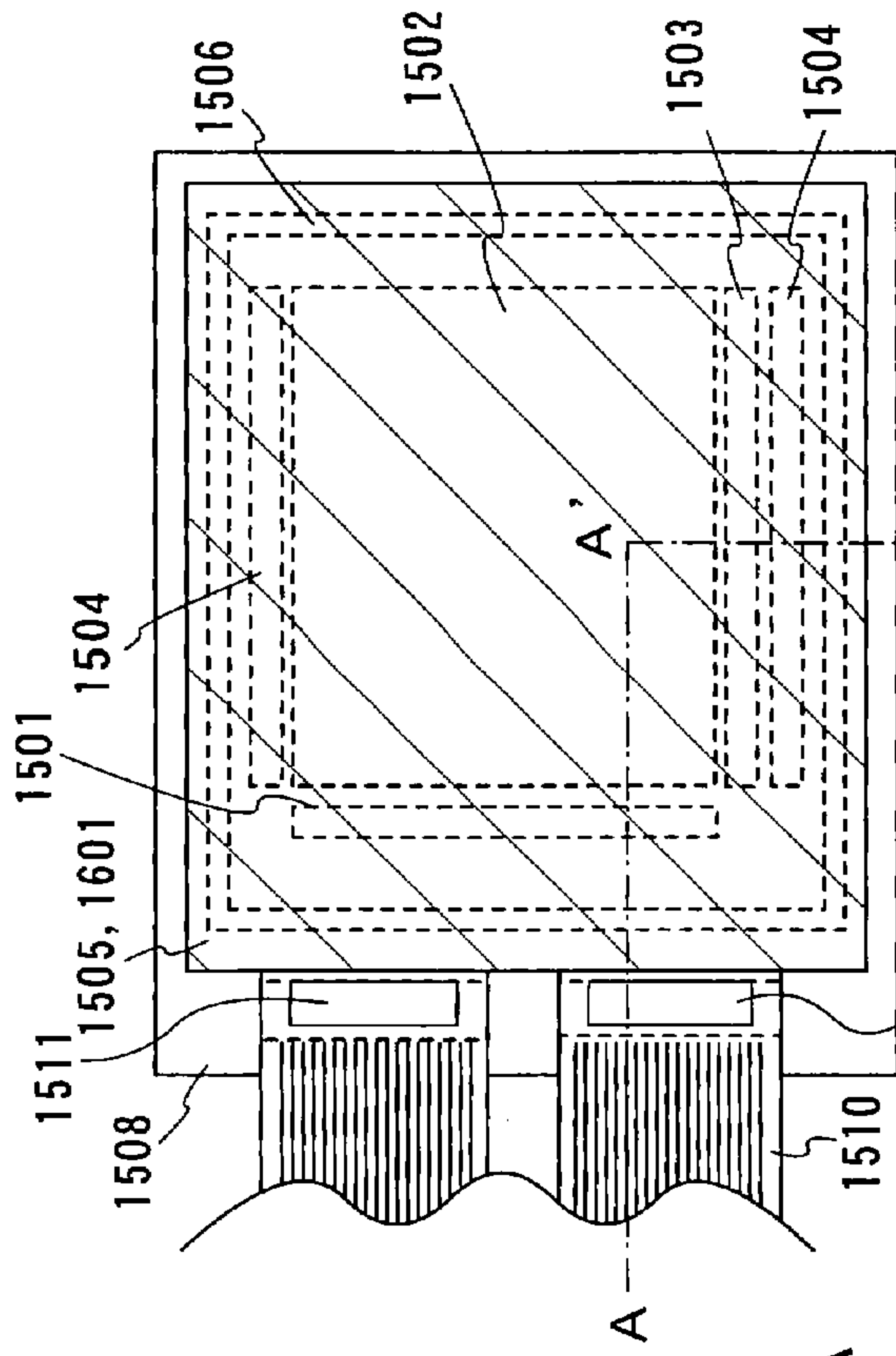

FIG. 16A

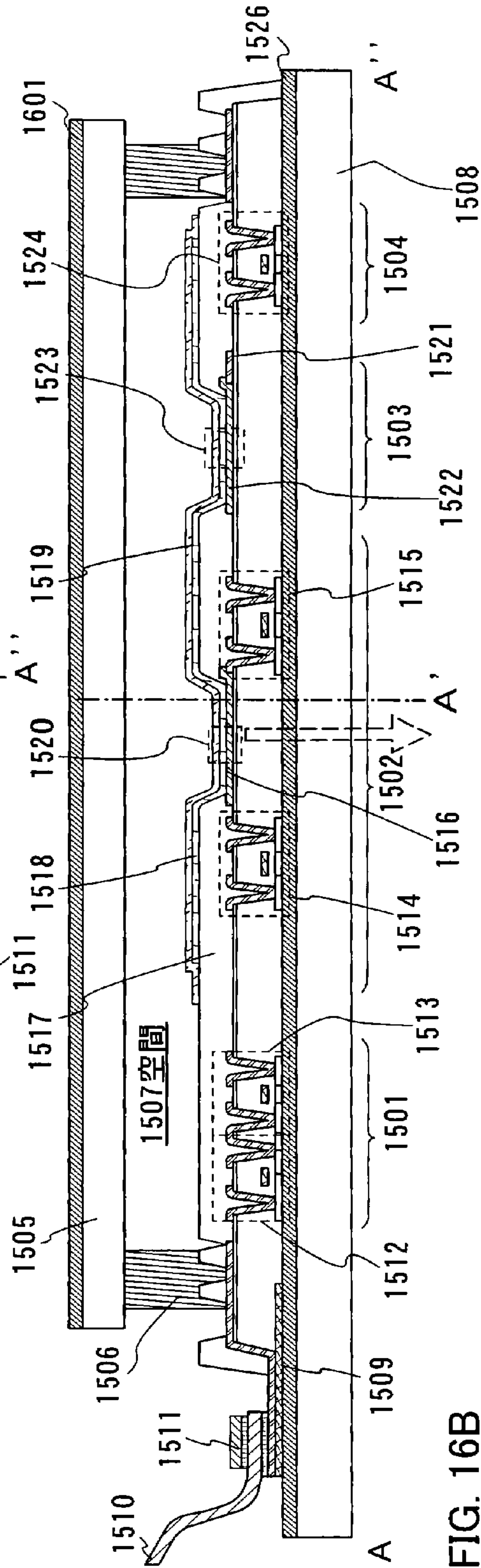

FIG. 16B

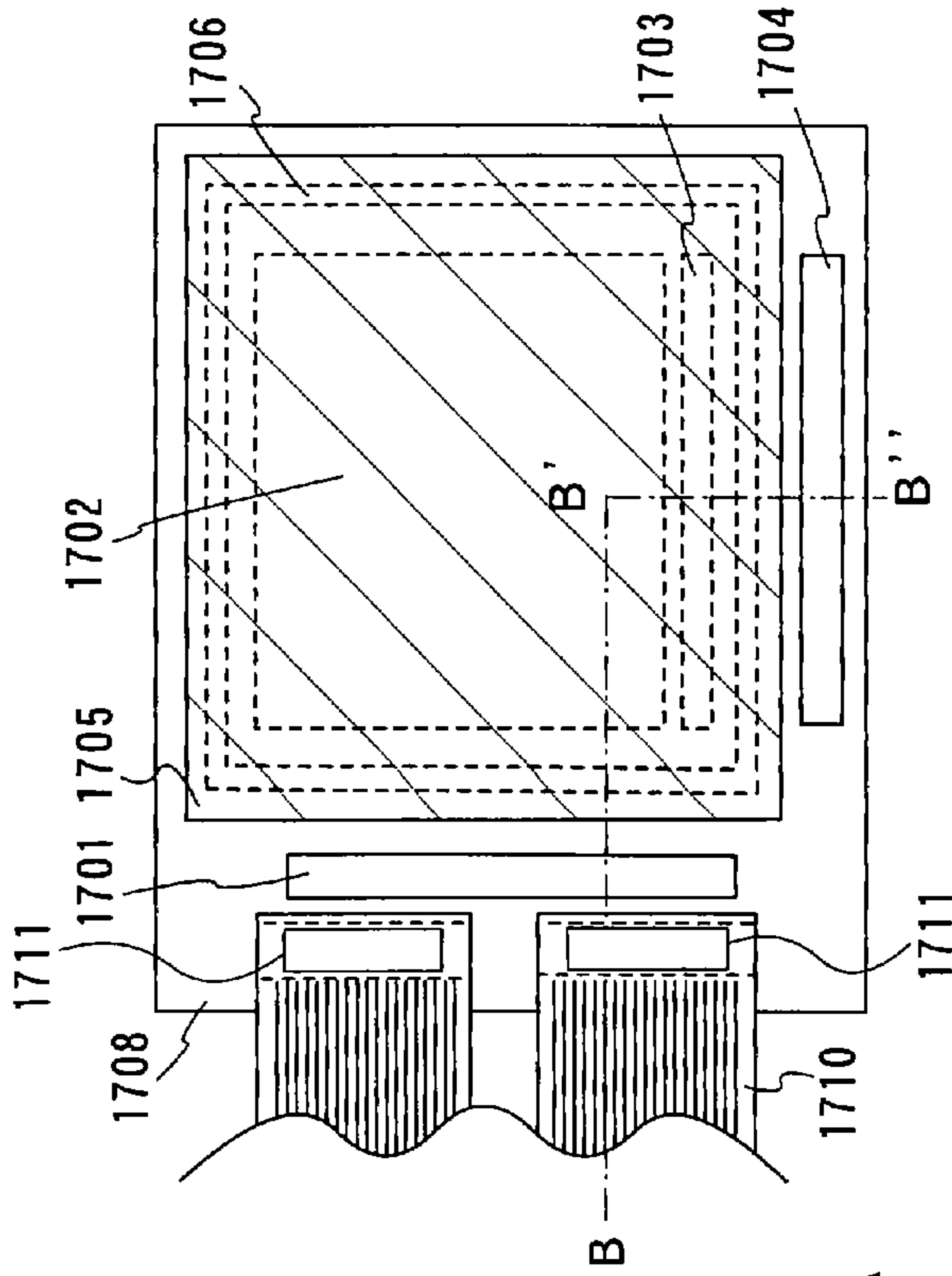

FIG. 17A

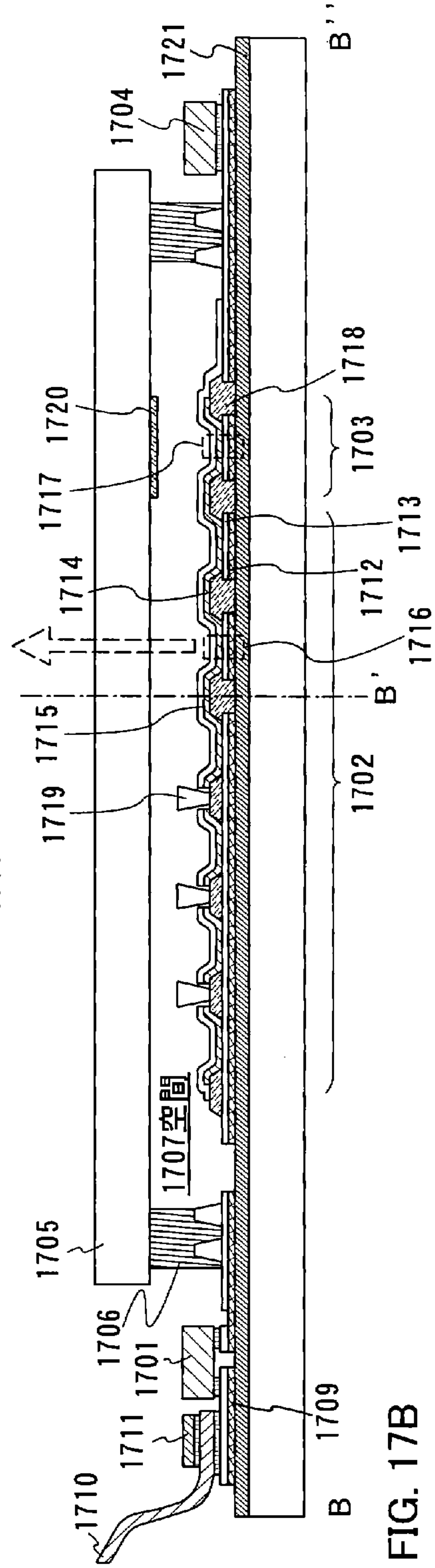

FIG. 17B

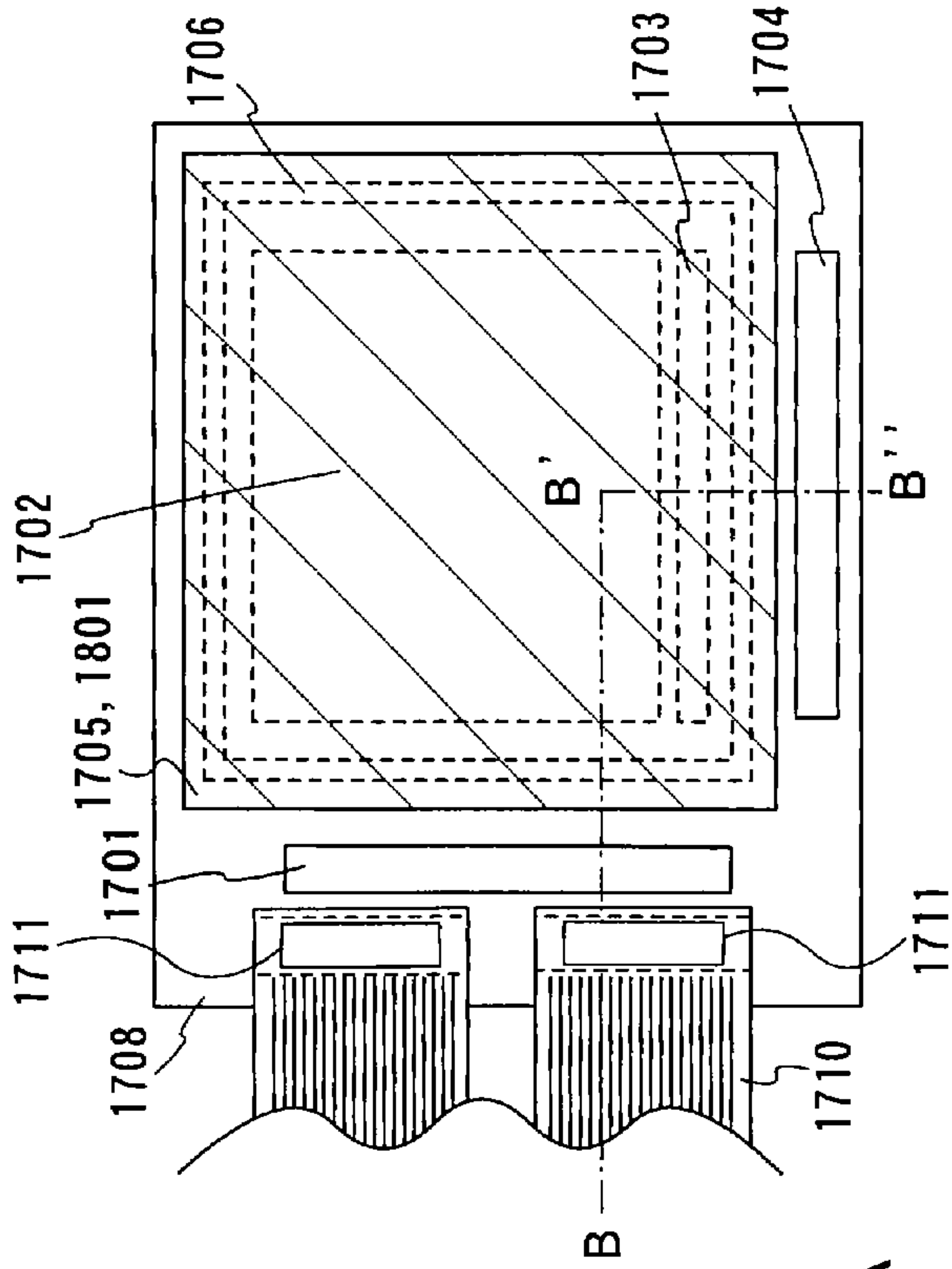

FIG. 18A

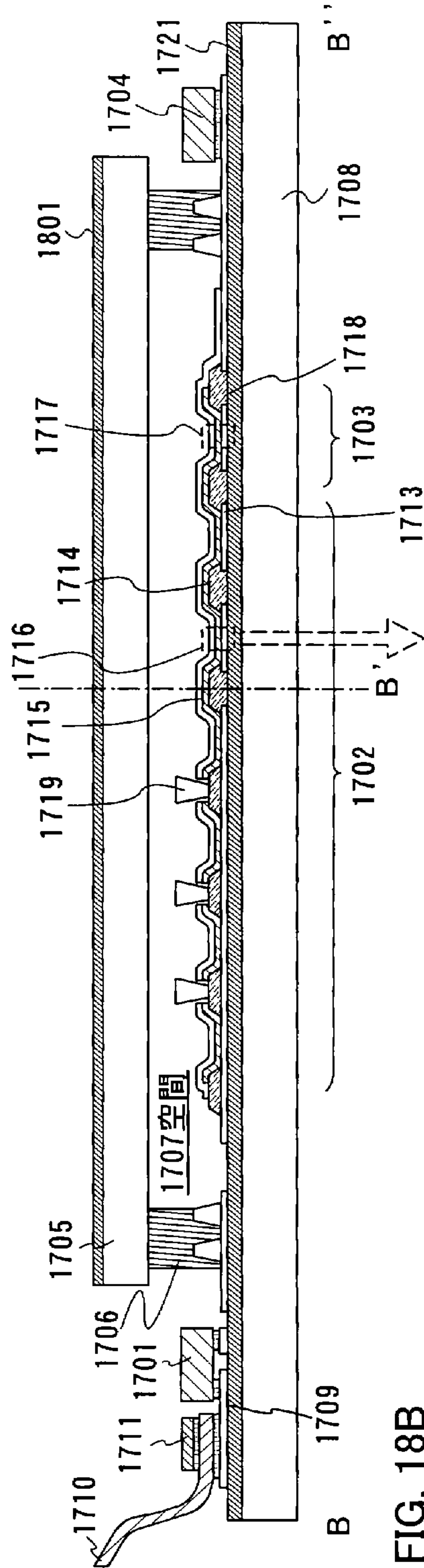

FIG. 18B

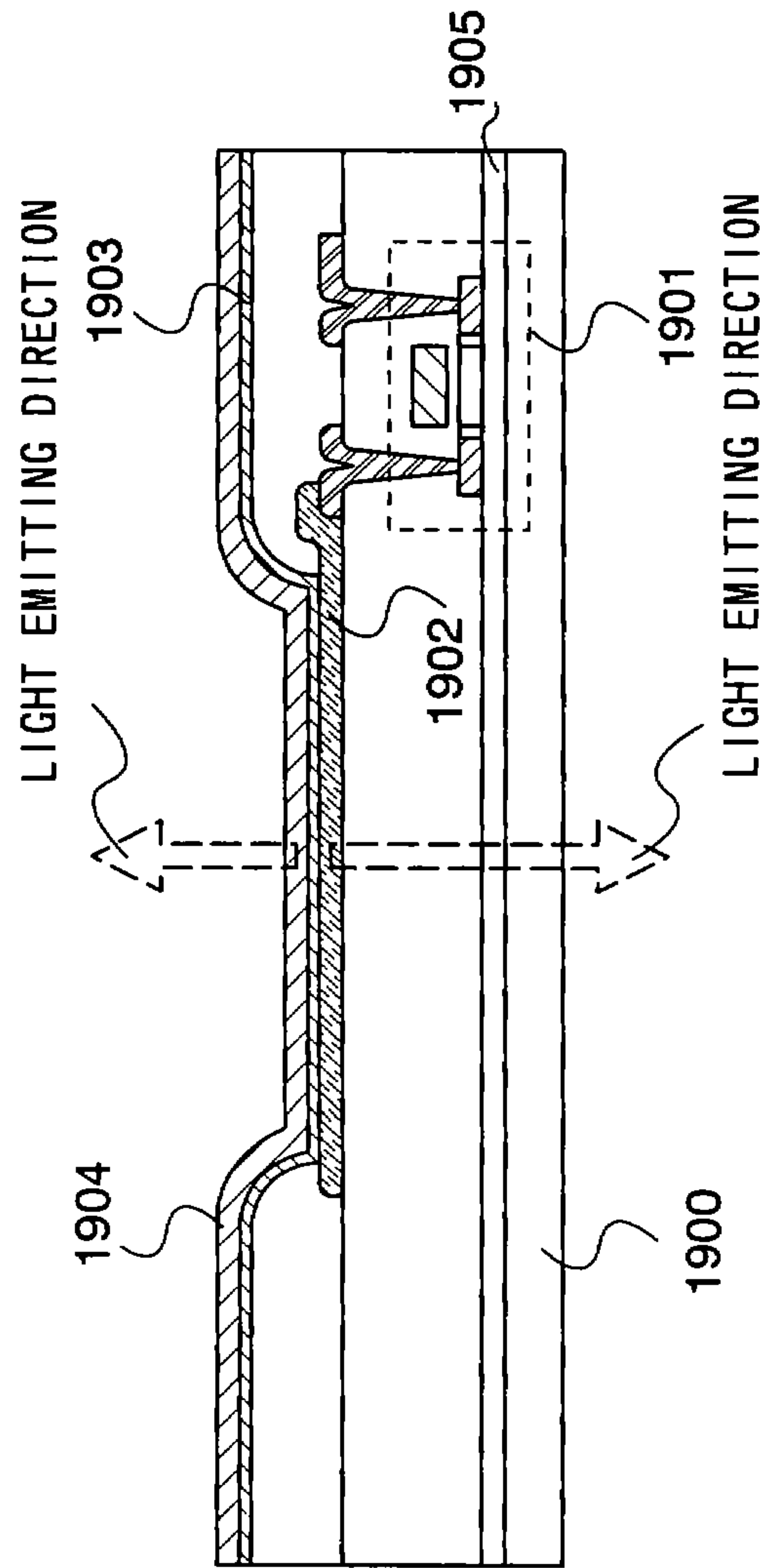

FIG. 19

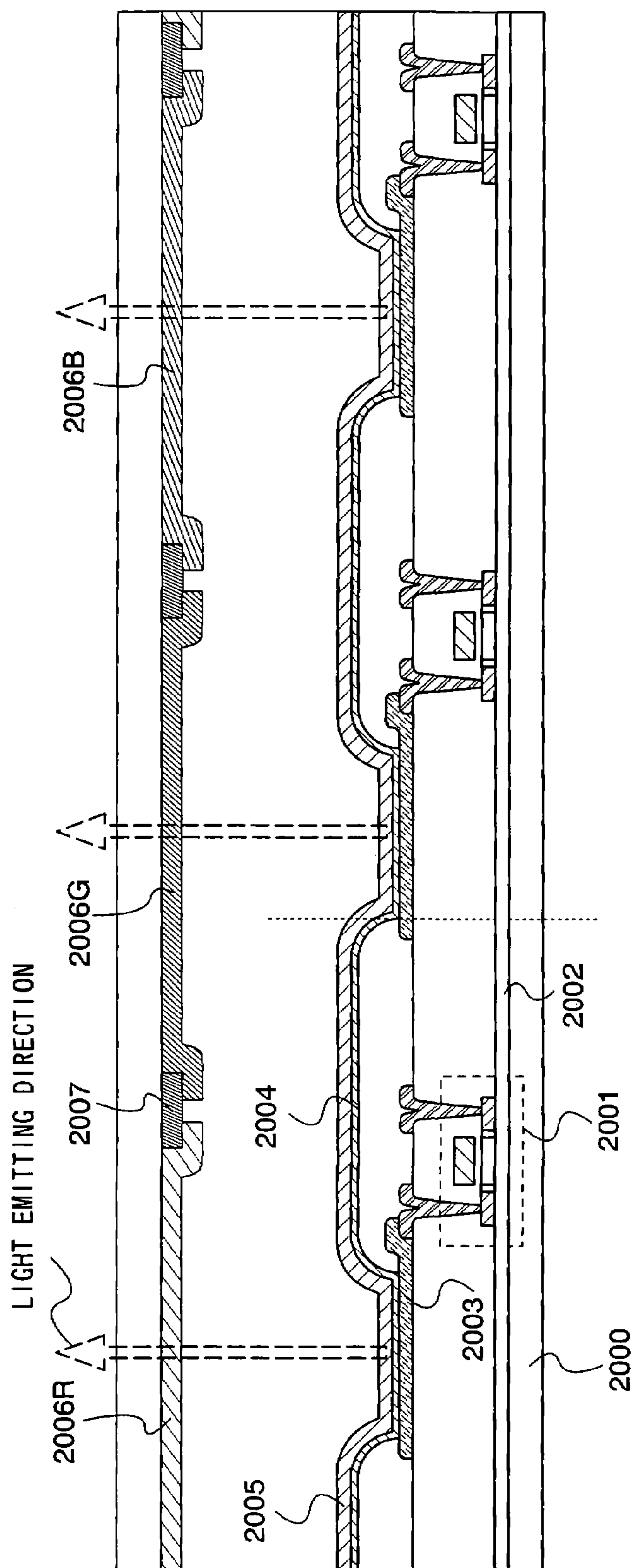

FIG. 20

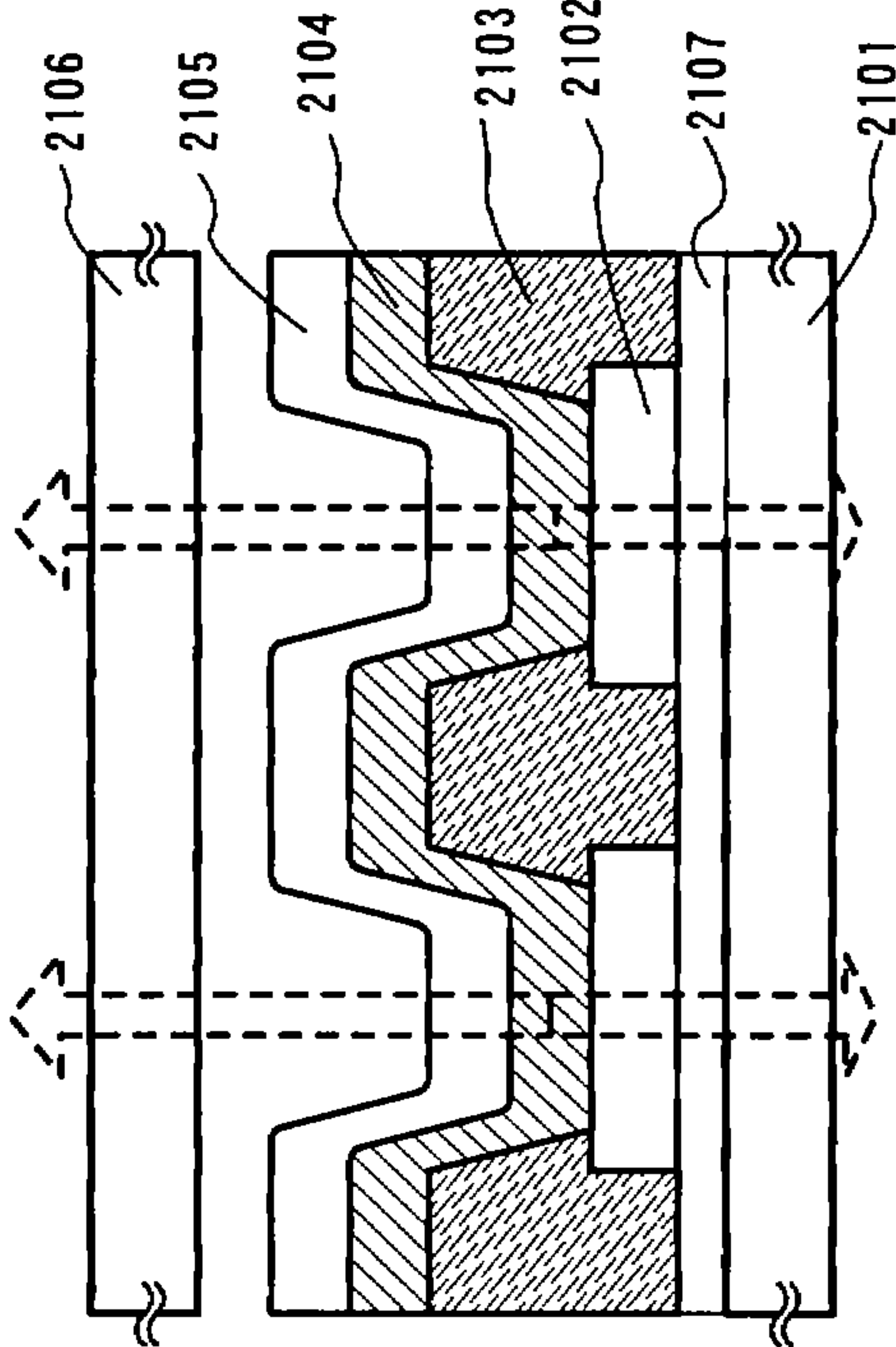

FIG. 21

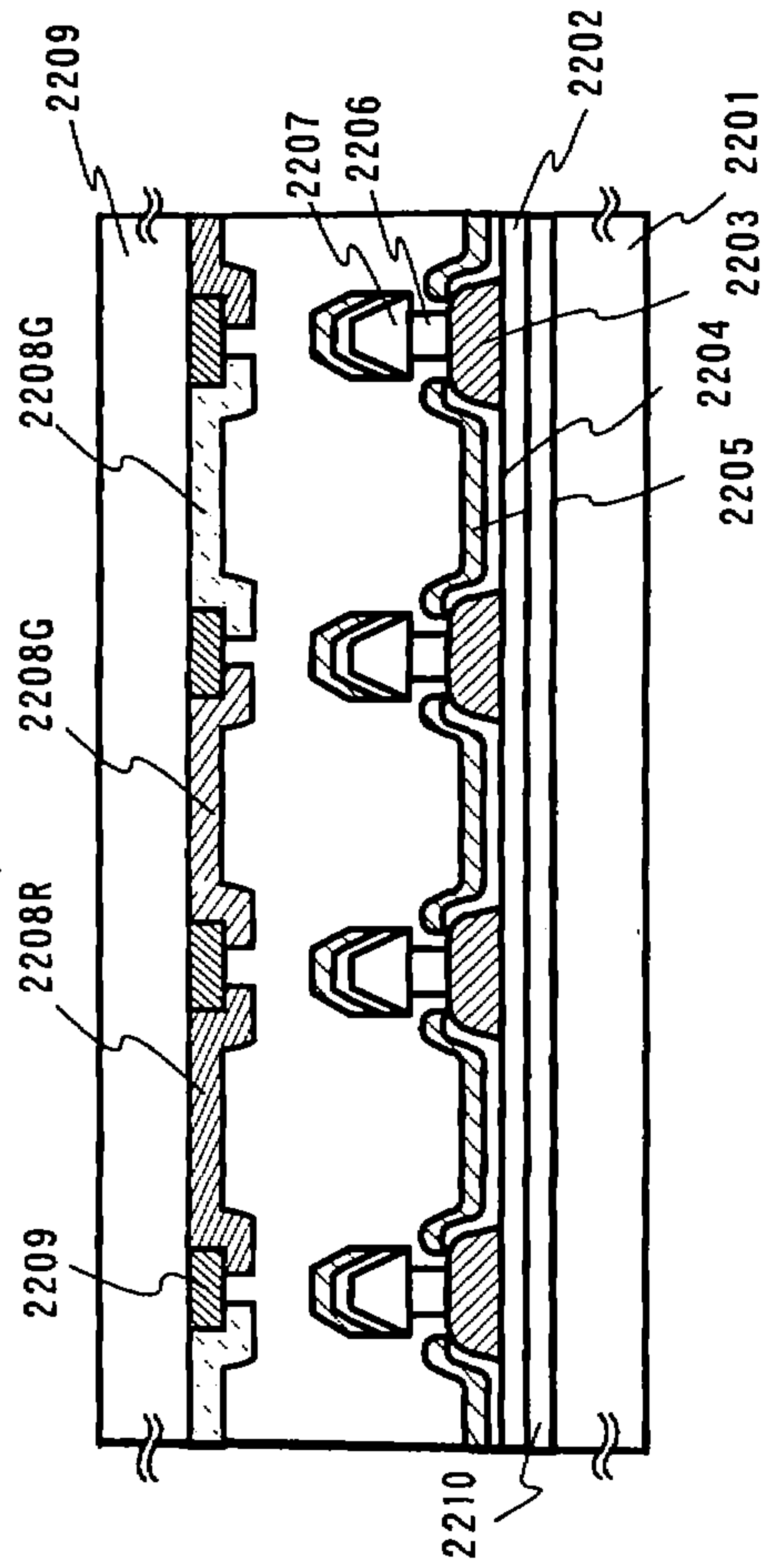

FIG. 22

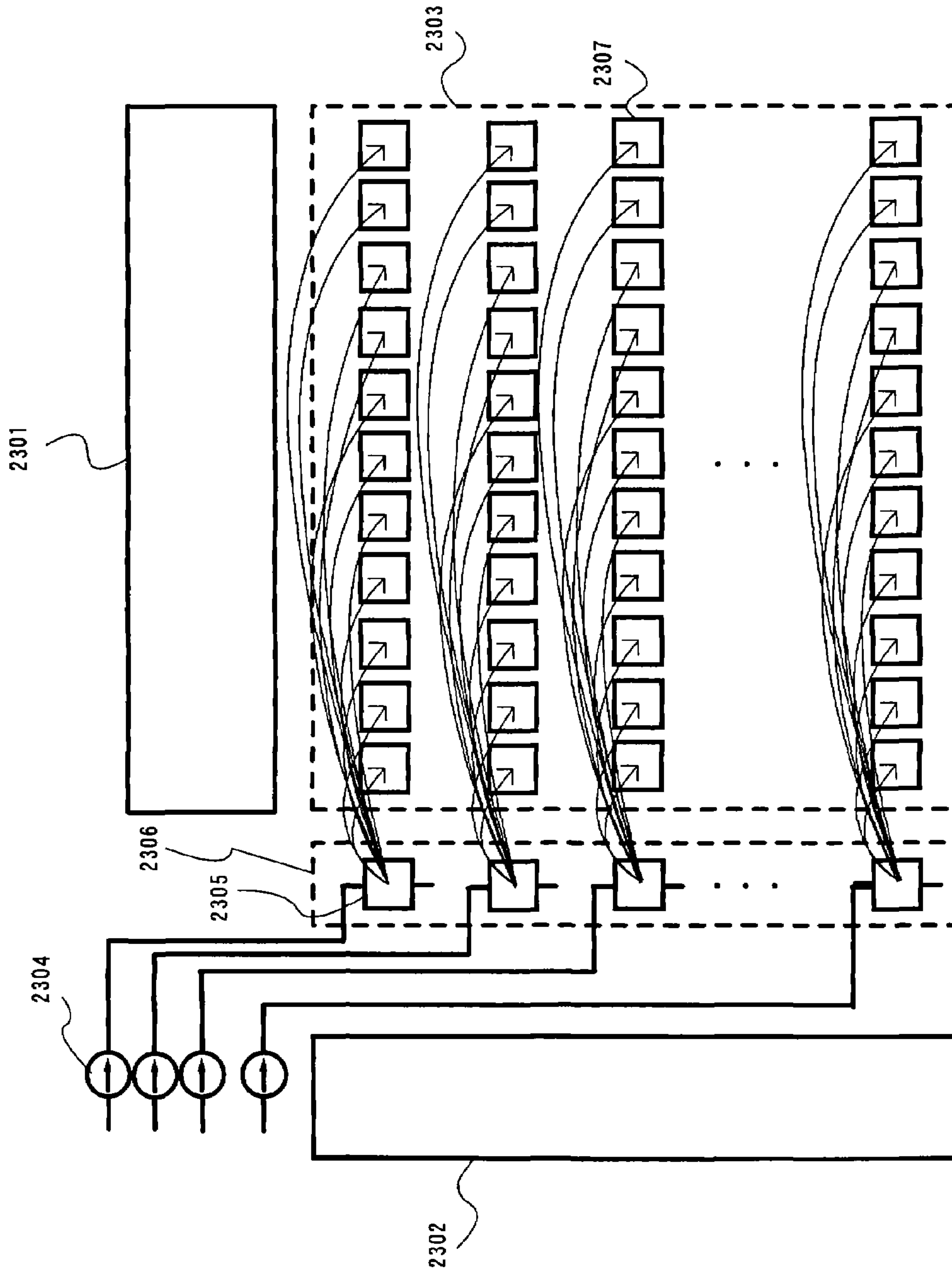

FIG. 23

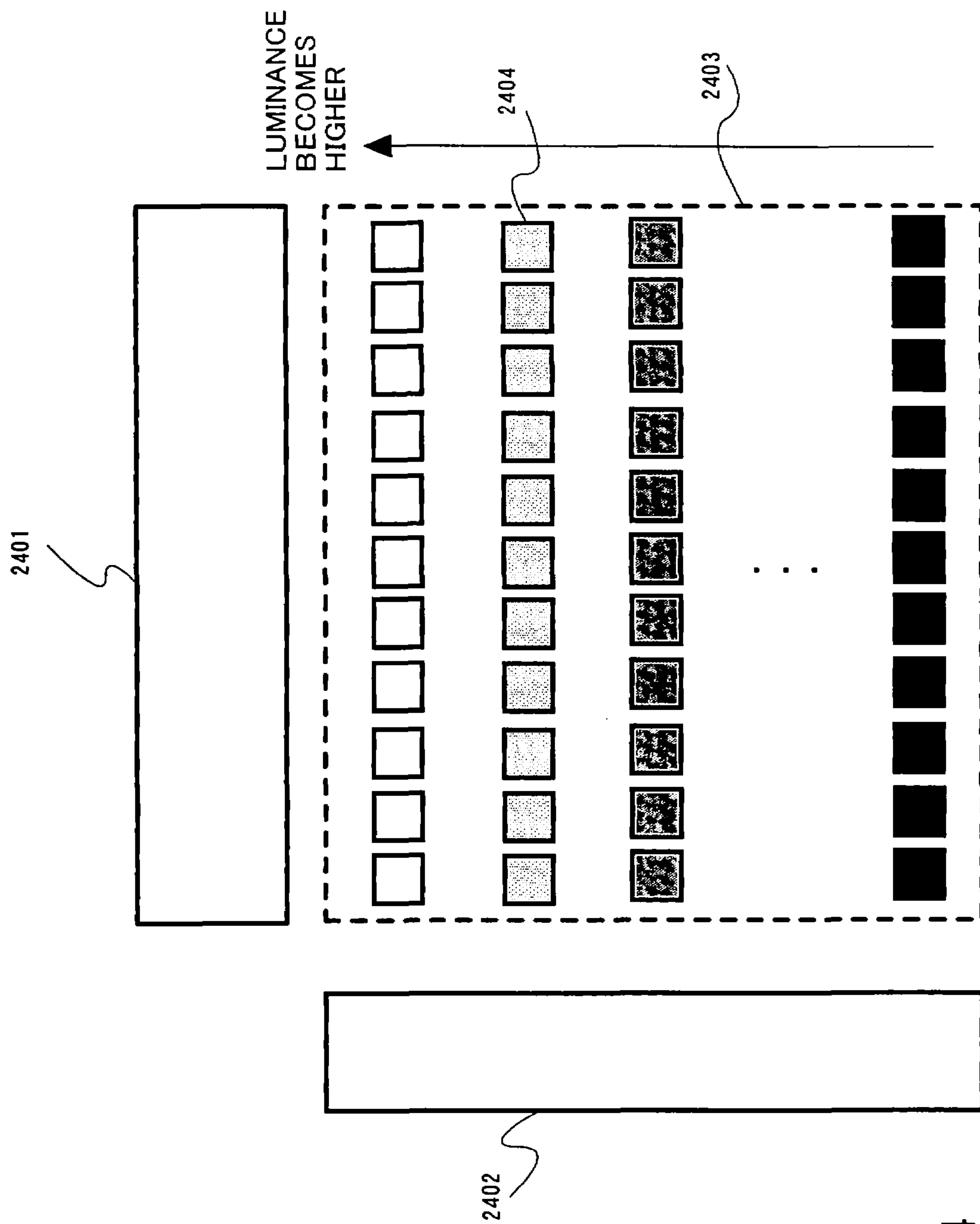

FIG. 24

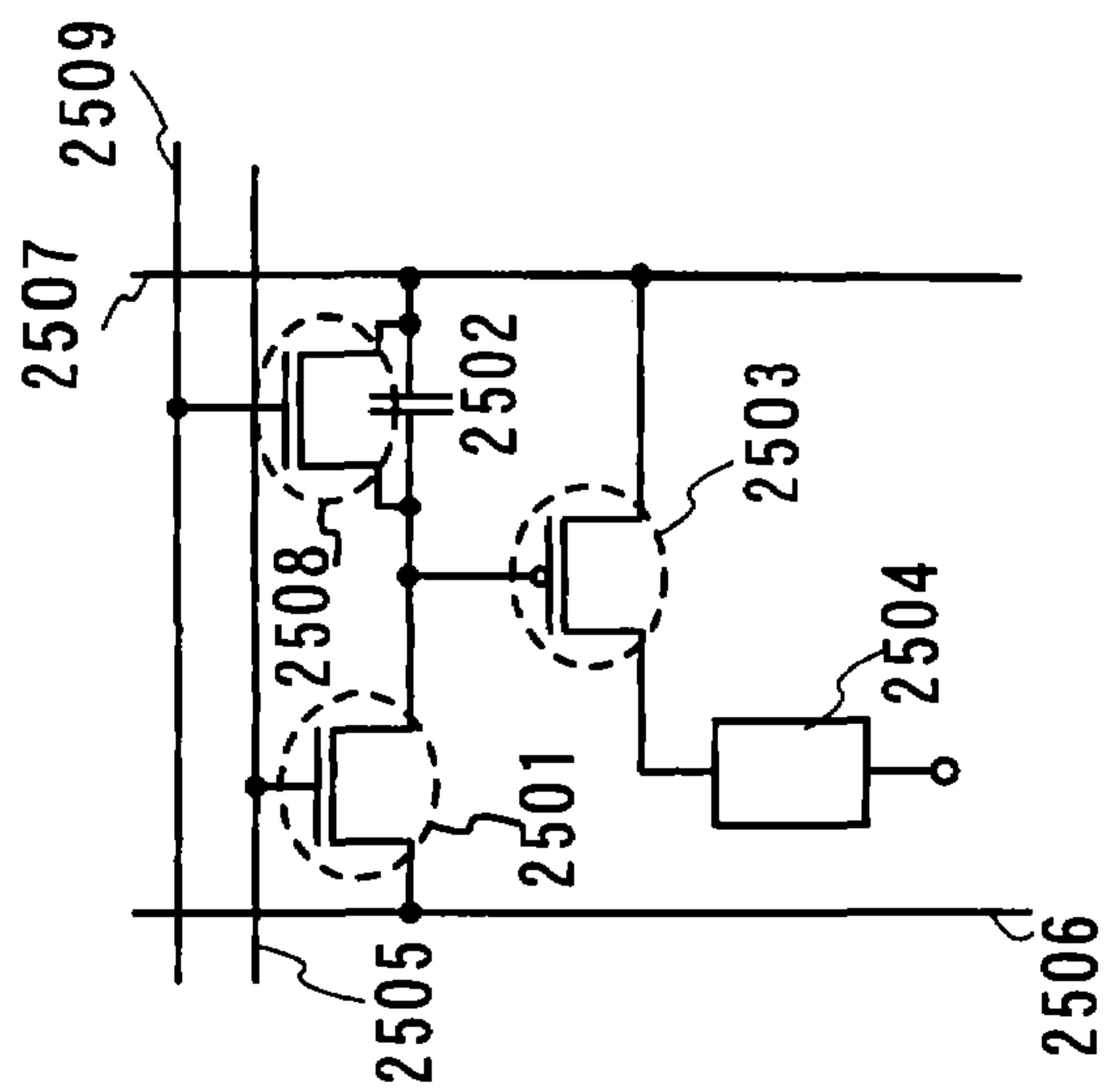

FIG. 25B

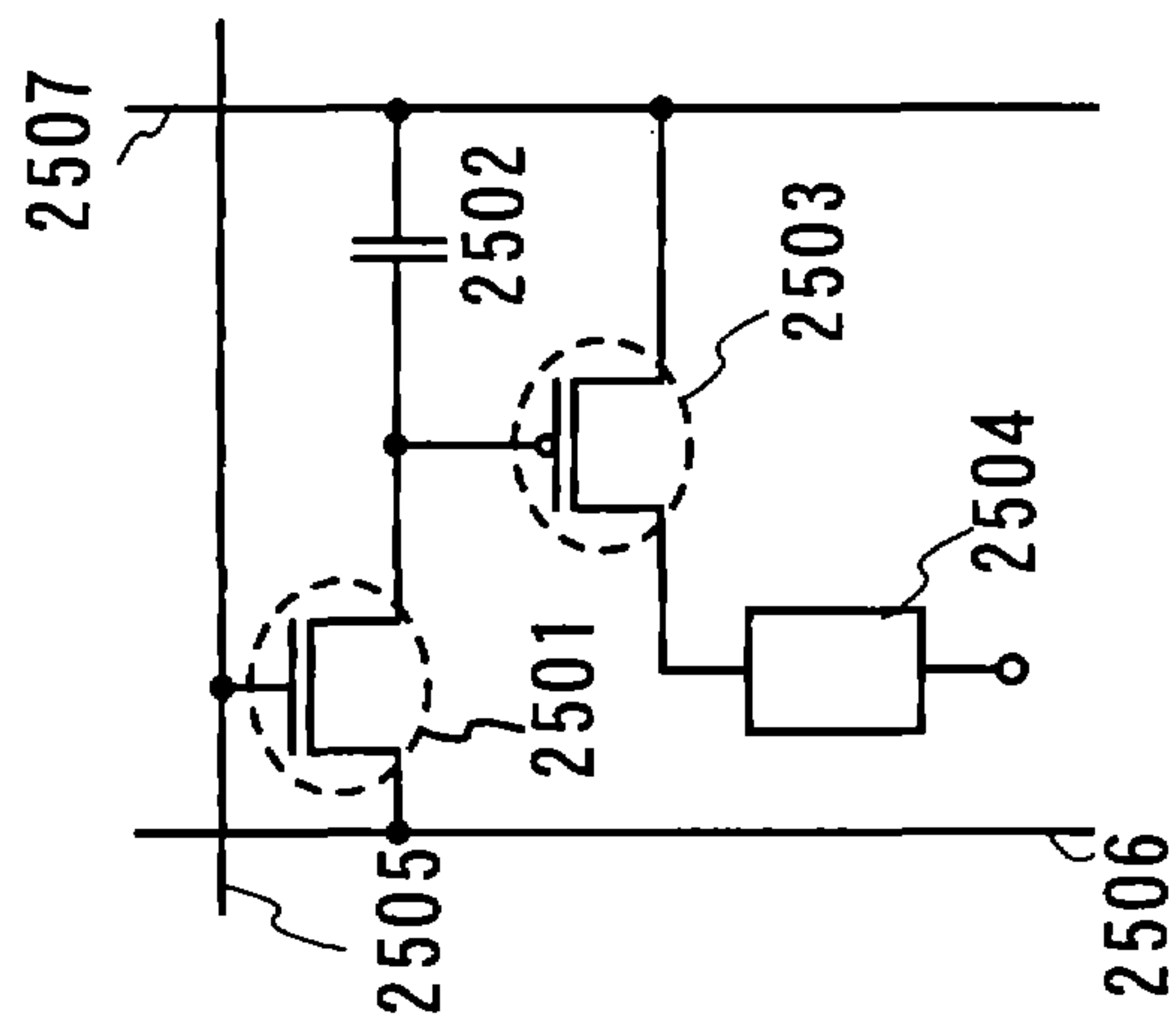

FIG. 25A

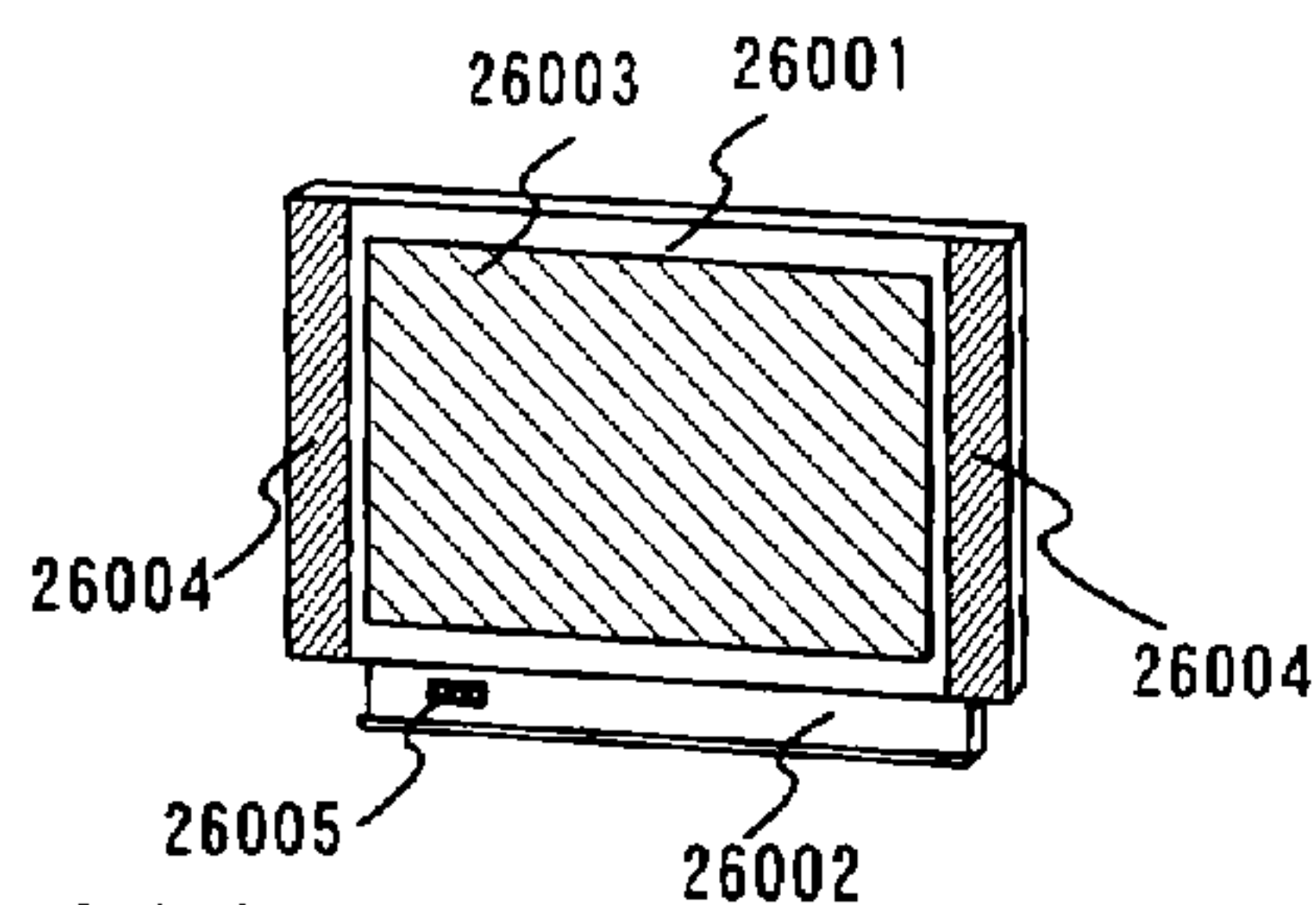

FIG. 26A

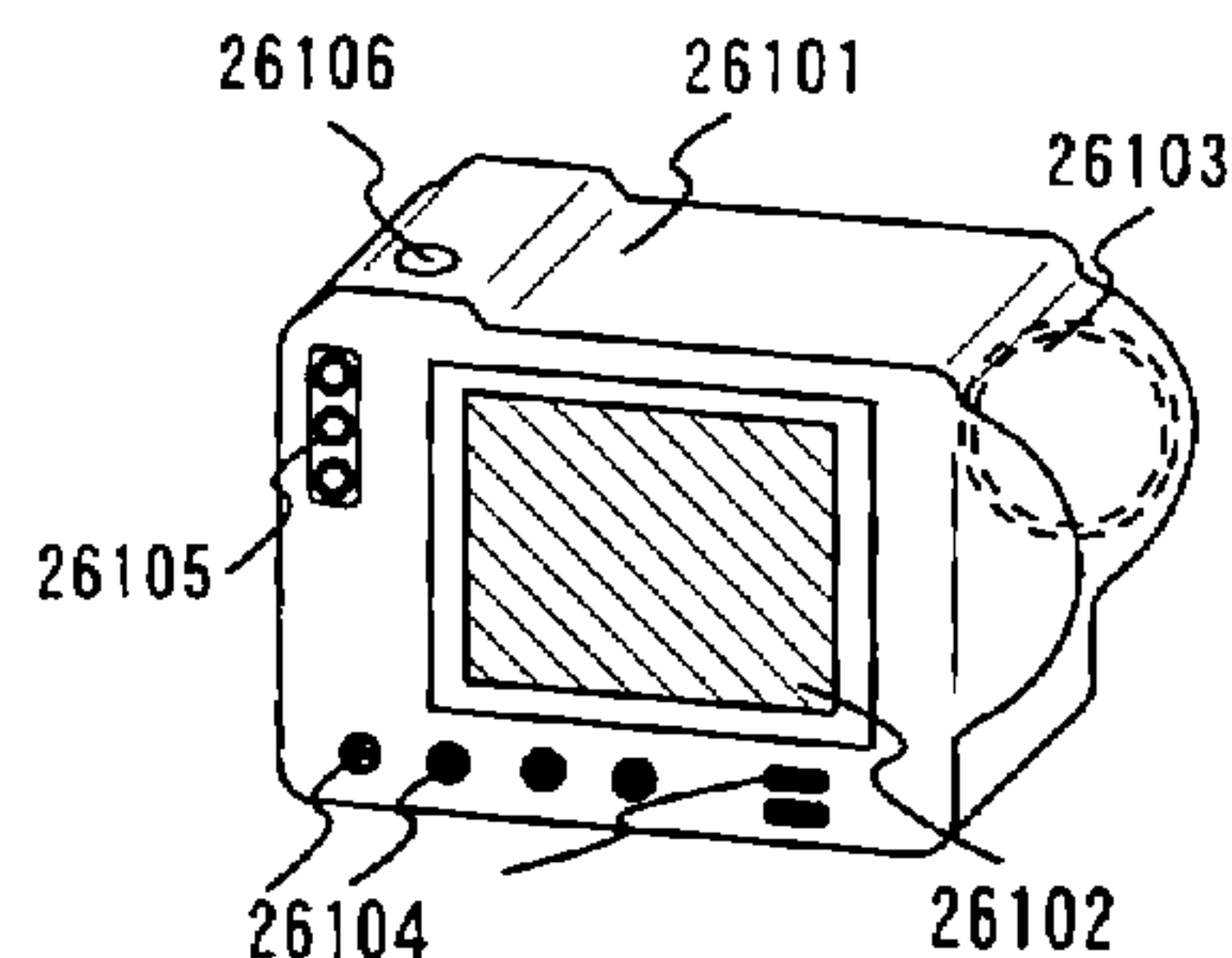

FIG. 26B

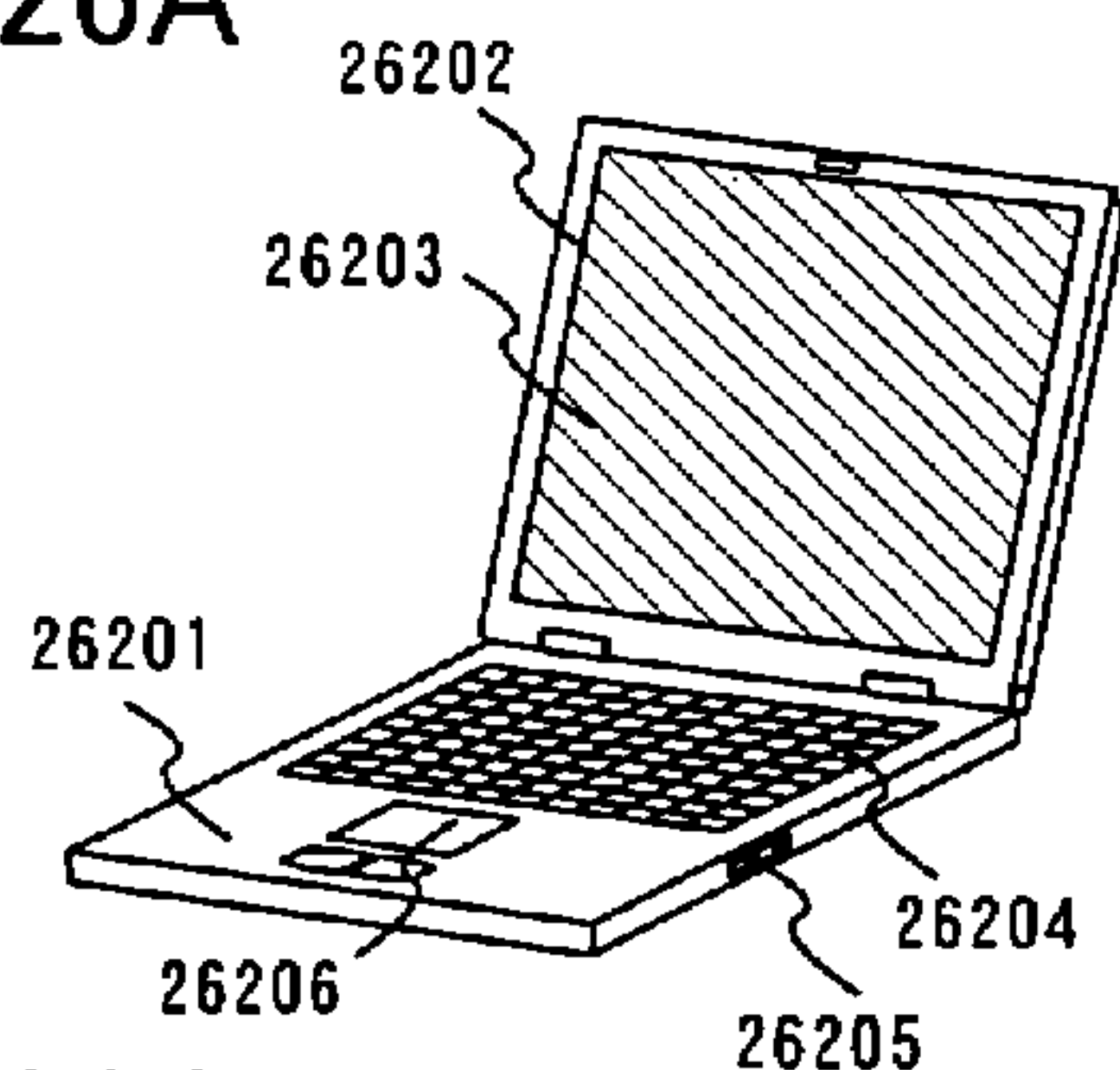

FIG. 26C

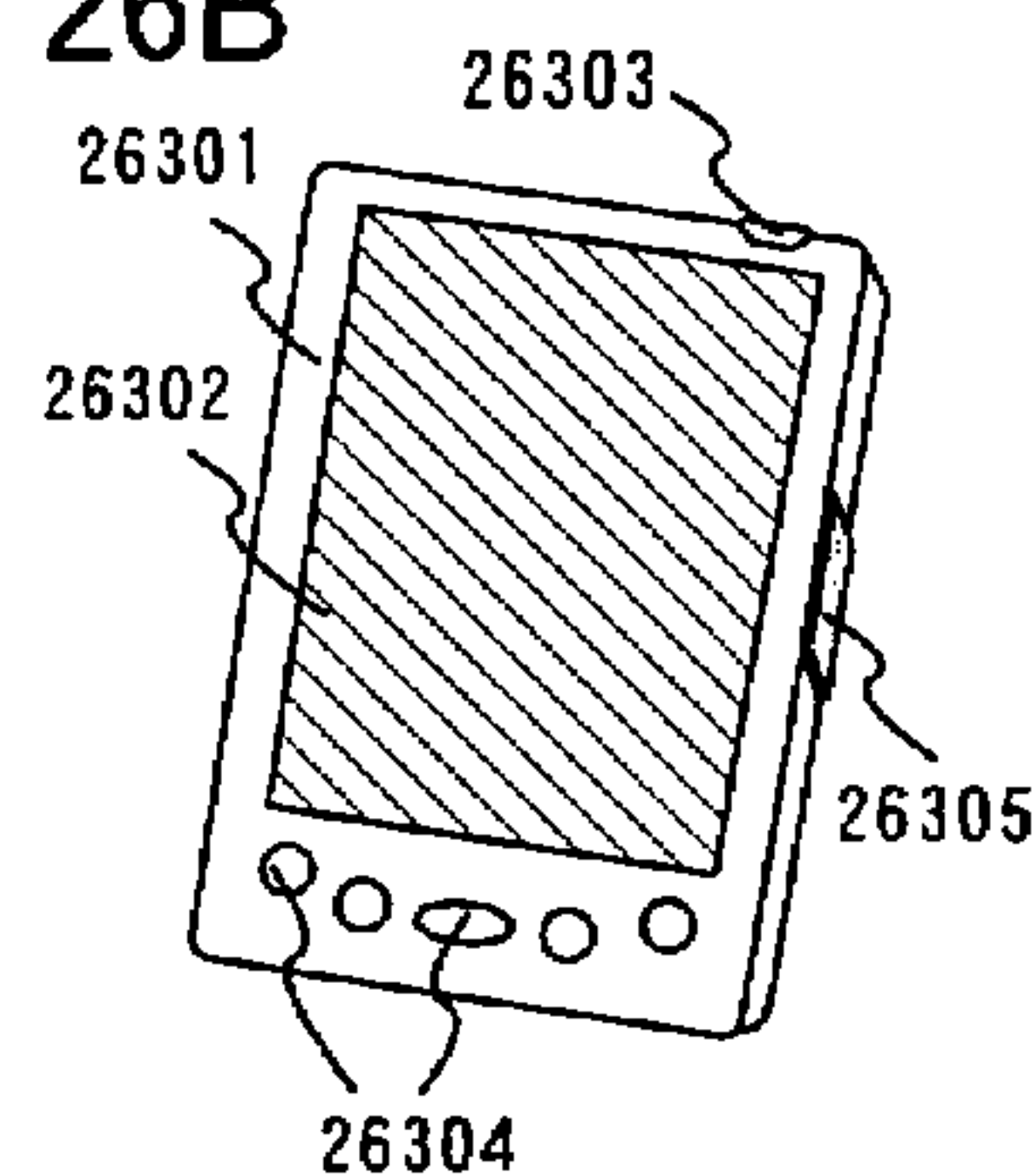

FIG. 26D

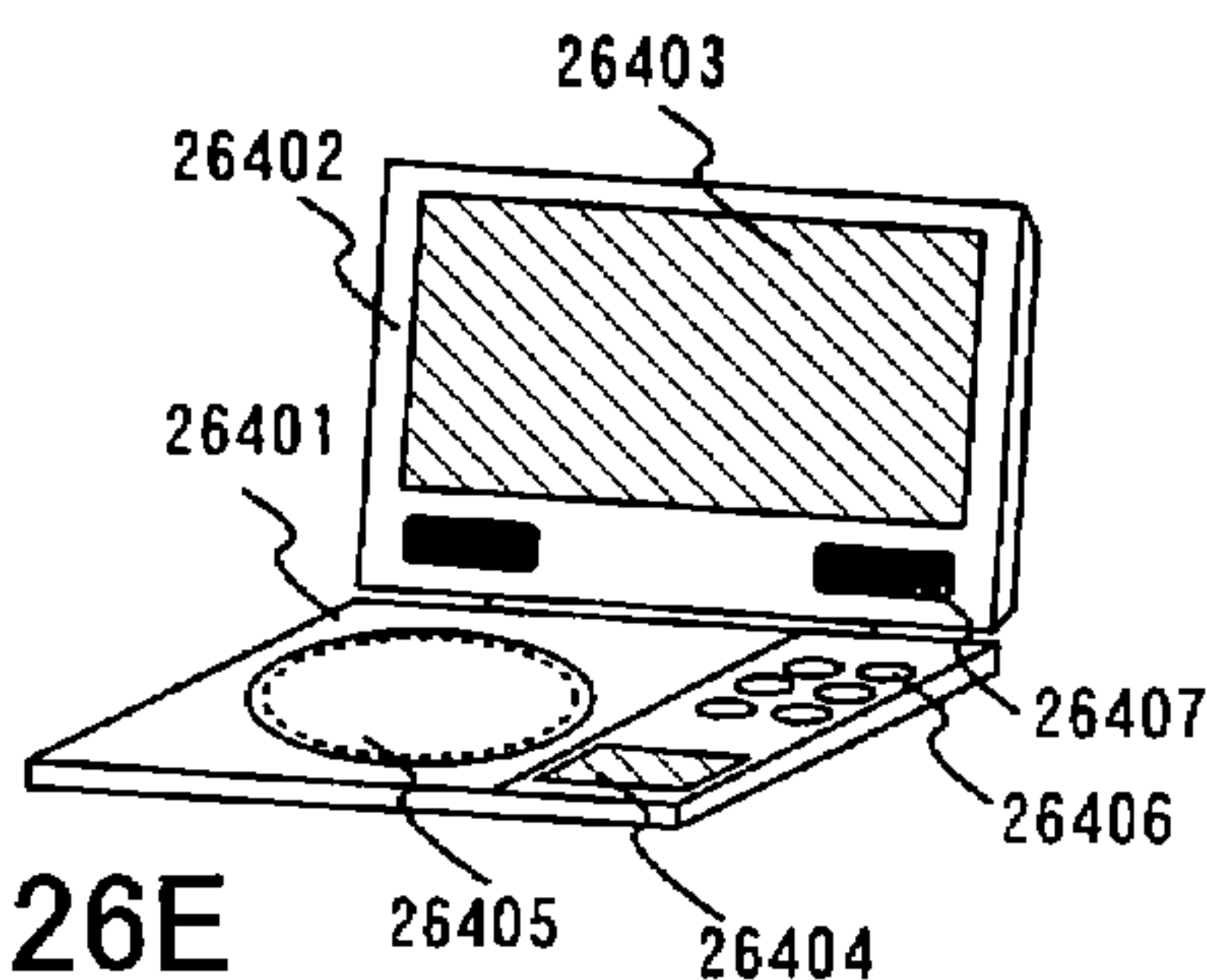

FIG. 26E

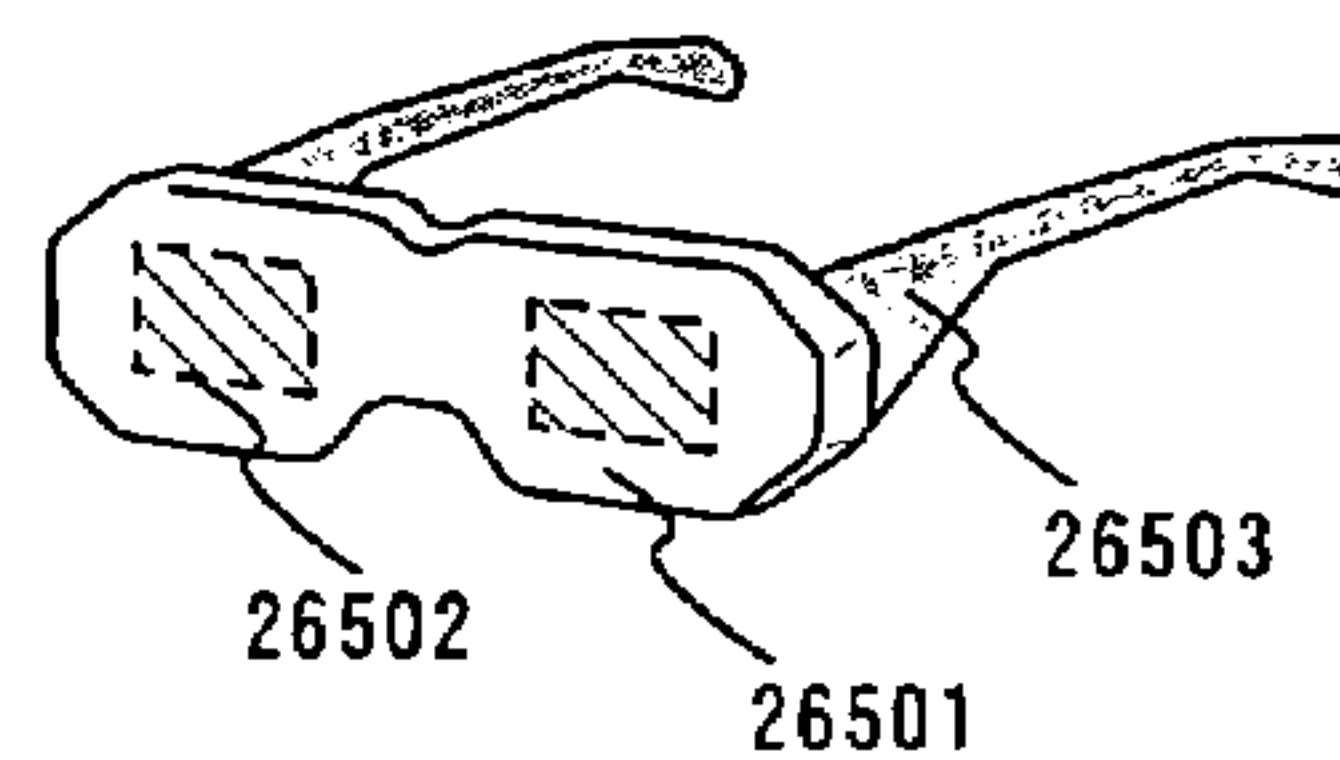

FIG. 26F

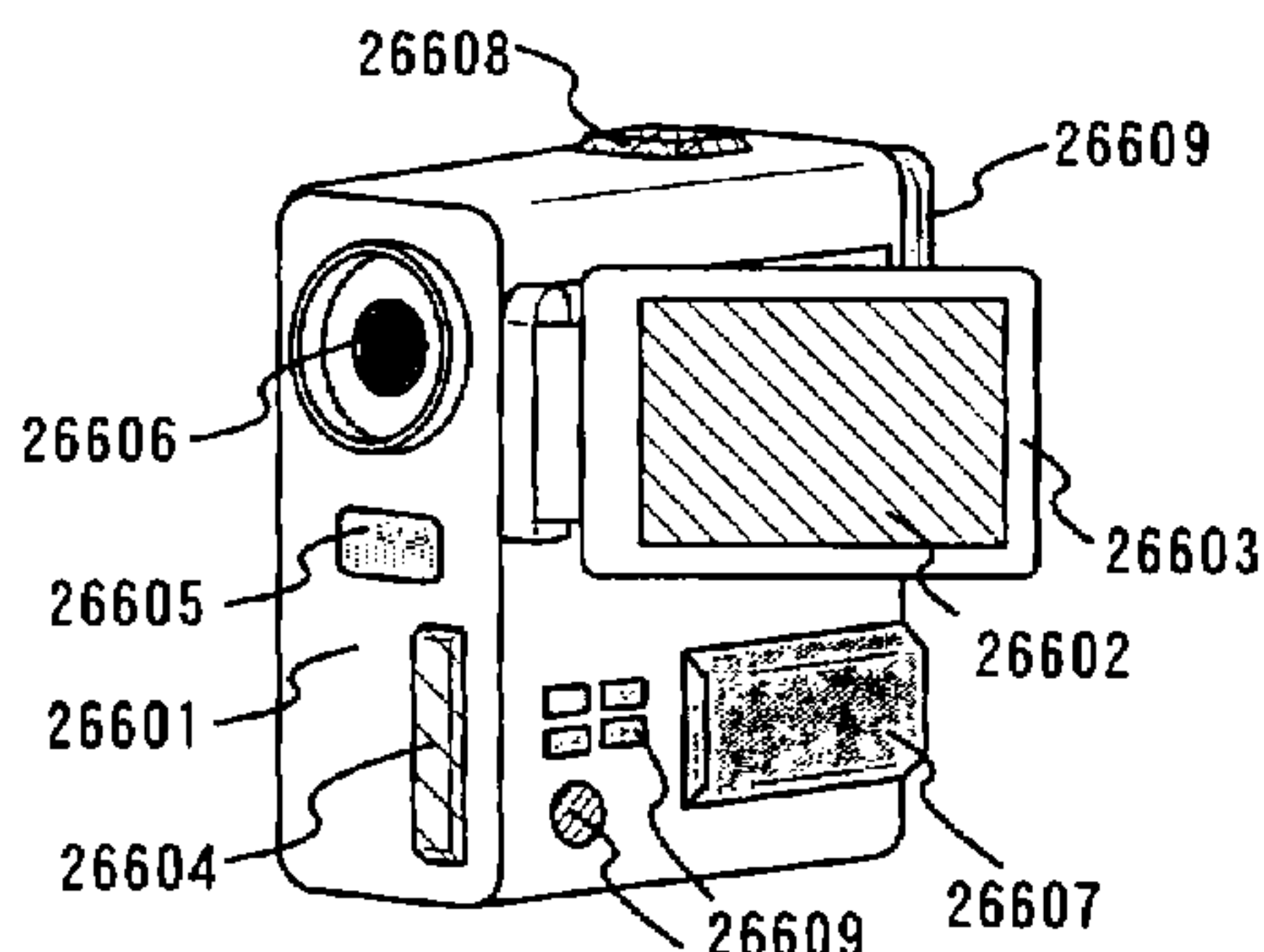

FIG. 26G

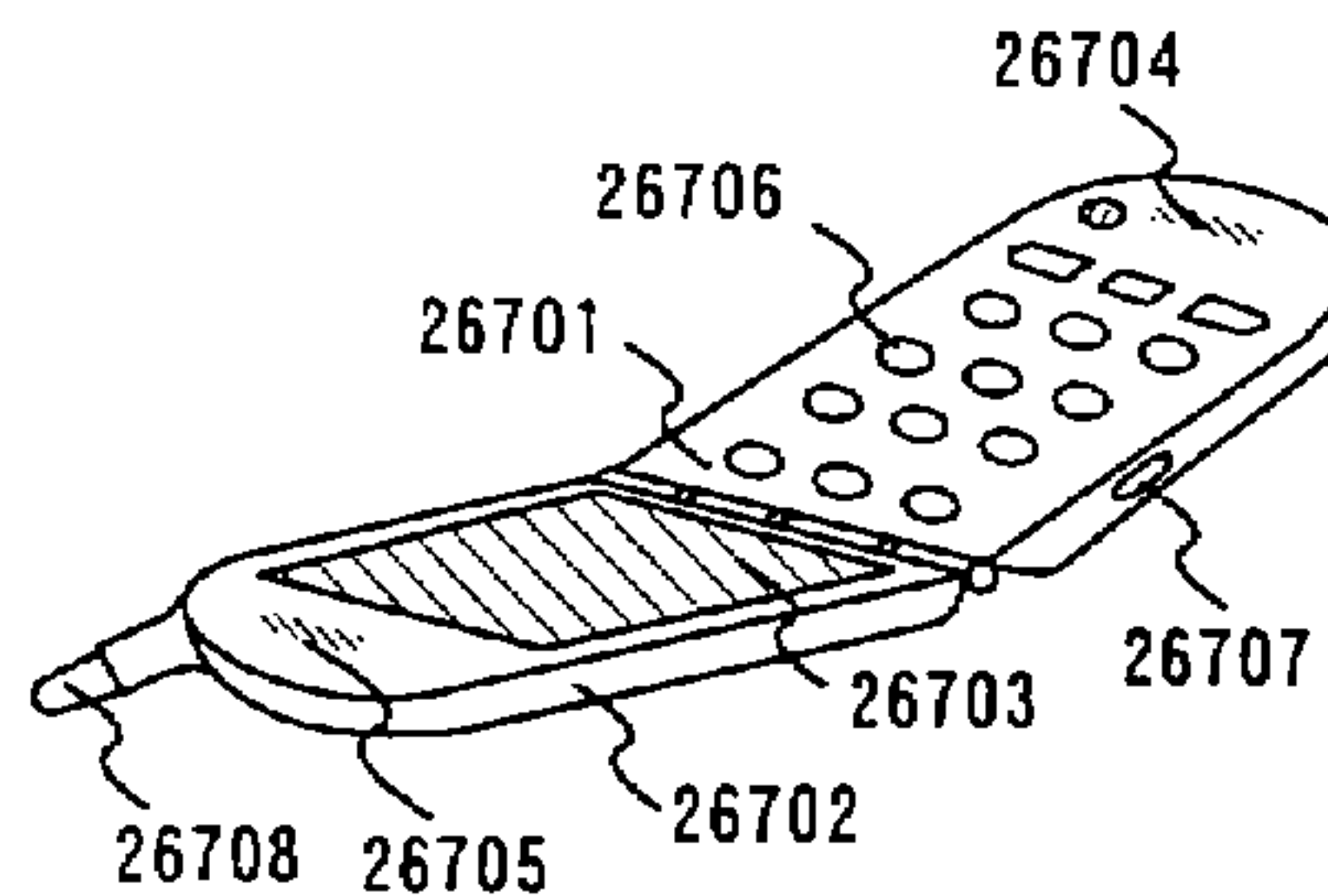

FIG. 26H

DISPLAY DEVICE AND ELECTRONIC DEVICE

CROSS-REFERENCE TO RELATED APPLICATIONS

This application is a continuation of U.S. application Ser. No. 11/201,375, filed Aug. 11, 2005, now allowed, which claims the benefit of a foreign priority application filed in Japan as Serial No. 2004-242820 on Aug. 23, 2004, both of which are incorporated by reference.

BACKGROUND OF THE INVENTION

1. Field of the Invention

The present invention relates to a semiconductor device provided with a function to control by a transistor a current supplied to a load. More particularly, the invention relates to a display device including a pixel formed of a current drive type light emitting element of which luminance changes according to a current, a signal line driver circuit thereof, and a driving method thereof. Further, the invention relates to an electronic device including the display device in a display portion.

2. Description of the Related Art

In recent years, so-called a self-luminous type display device of which pixels are formed of light emitting elements such as light emitting diodes (LEDs) is attracting attention. As a light emitting element used for such a self-luminous type display device, an organic light emitting diode (OLED), an organic EL element, and an electroluminescence (EL) element are attracting attention and becoming to be used for an organic EL display and the like.

A light emitting element such as an OLED which emits light by itself is advantageous in that visibility of pixels is higher as compared to a liquid crystal display, a backlight is not required, and response is fast. The luminance of a light emitting element is controlled by a current value supplied to the light emitting element. Therefore, a constant current drive in which a constant amount of current is supplied to the light emitting element is suggested for accurately displaying gray scales (see Patent Document 1).

[Patent Document 1]

Japanese Patent Laid-Open No. 2003-323159

A light emitting element has a property that resistance (internal resistance) changes in accordance with the temperature. In specific, when the temperature becomes higher than the normal temperature, the resistance decreases while the resistance increases when the temperature becomes lower than the normal temperature. Accordingly, when the temperature rises, a luminance higher than desired is obtained as a current value increases and the current value decreases when the temperature falls, even though a constant voltage is applied by a constant voltage drive.

Due to the aforementioned properties of a light emitting element, luminance thereof varies when the temperature changes. In view of the aforementioned, the invention provides a display device which suppresses the influence of luminance variations of a light emitting element due to a temperature change.

SUMMARY OF THE INVENTION

A display device of the invention includes a pixel portion including a plurality of light emitting elements of which resistance changes by a temperature change, and a voltage source for supplying a voltage to the light emitting elements.

In the case where there is a temperature gradient in a pixel portion and a difference in temperature generates among the light emitting elements, the voltage source has a unit for supplying a lower voltage to a light emitting element of a high temperature and a higher voltage to a light emitting element of a low temperature.

Further, a display device of the invention includes a first signal line driver circuit which outputs a signal to a plurality of first signal lines provided in a column direction, a second signal line driver circuit which outputs a signal to a plurality of second signal lines provided in a row direction, and a pixel portion in which pixels are arranged in matrix corresponding to a column direction of the first signal line and a row direction of the second signal line. The pixel includes a light emitting element. The display device further includes a monitor element provided beside the light emitting elements in a periphery of the pixel portion for each row of the pixels, a current source which supplies a current to the monitor element, and an amplifier for applying approximately the same voltage as a voltage generated in the monitor element to the light emitting element provided beside the monitor element.

A display device of the invention includes a first signal line driver circuit which outputs a signal to a plurality of first signal lines provided in a column direction, a second signal line driver circuit which outputs a signal to a plurality of second signal lines provided in a row direction, and a pixel portion in which pixels are arranged in matrix corresponding to the column direction of the first signal line and the row direction of the second signal line. The pixel includes a light emitting element. The display device further includes a monitor element provided beside the light emitting elements for each row of the pixels in a periphery of the pixel portion, a current source which supplies a current to the monitor element, and an amplifier for inputting approximately the same potential as a potential of an anode of the monitor element to an anode of the light emitting elements provided beside the monitor element.

A display device of the invention includes a first signal line driver circuit which outputs a signal to a plurality of first signal lines provided in a column direction, a second signal line driver circuit which outputs a signal to a plurality of second signal lines provided in a row direction, and a pixel portion in which pixels are arranged in matrix corresponding to the column direction of the first signal line and the row direction of the second signal line. The pixel includes a light emitting element. The display device further includes a monitor element provided beside the light emitting elements for each row of the pixels in a periphery of the pixel portion, a current source which supplies a current to a plurality of monitor elements provided in a plurality of rows of the pixels, and an amplifier for applying approximately the same voltage as a voltage in the plurality of monitor elements to a plurality of rows of light emitting elements provided beside the plurality of monitor elements. Among the plurality of monitor elements provided for rows of the pixels, a plurality of monitor elements provided beside the plurality of light emitting elements to which the amplifier applies a voltage are connected in parallel.

According to a display device of the invention having the aforementioned structure, the amplifier is a voltage follower circuit.

According to a display device of the invention having the aforementioned structure, the pixel portion is formed of pixels with a plurality of color components, and the monitor element and the amplifier are provided for each color component.

According to a display device of the invention having the aforementioned structure, the monitor elements and the light emitting elements are EL elements.

According to a display device of the invention having the aforementioned structure, the monitor elements and the light emitting elements are formed of the same material.

According to an electronic device of the invention, the aforementioned display device is provided in a display portion.

An active matrix display device of the invention includes a source signal line driver circuit which outputs a signal to a plurality of source signal lines provided in a column direction, a gate signal line driver circuit which outputs a signal to a plurality of gate signal lines provided in a row direction, and a pixel portion in which pixels are arranged in matrix corresponding to the column direction of the source signal lines and the row direction of the gate signal lines. The pixel includes a light emitting element and a transistor which drives the light emitting element. The active matrix display device further includes a monitor element provided beside the light emitting elements for each row of the pixels in a periphery of the pixel portion, a current source which supplies a current to the monitor element, and an amplifier which inputs approximately the same potential as a potential of an anode of the monitor element to a source terminal of the transistor which drives the light emitting element provided beside the monitor element are provided.

Further, an active matrix display device of the invention includes a source signal line driver circuit which outputs a signal to a plurality of source signal lines provided in a column direction, a gate signal line driver circuit which outputs a signal to a plurality of gate signal lines provided in a row direction, and a pixel portion in which pixels are arranged in matrix corresponding to the column direction of the source signal lines and the row direction of the gate signal lines. The pixel includes a light emitting element and a transistor which drives the light emitting element. The active matrix display device further includes a monitor element provided beside the light emitting elements for each row of the pixels at the next to the pixel portion, a current source which supplies a current to a plurality of monitor elements provided in a plurality of rows of the pixels, and an amplifier which inputs approximately the same potential as a potential of an anode of the monitor element(s) to a source terminal of the transistor which drives the light emitting element provided beside the monitor element. Among the plurality of monitor elements provided for each row of the pixels, a plurality of monitor elements provided beside the plurality of rows of light emitting elements to which the amplifier applies a voltage are connected in parallel.

Further, according to an active matrix display device of the invention having the aforementioned structure, the amplifier is a voltage follower circuit.

According to an active matrix display device of the invention having the aforementioned structure, the pixel portion is formed of pixels with a plurality of color components, and the monitor element and the amplifier are provided for each color component.

According to an active matrix display device of the invention having the aforementioned structure, the monitor element and the light emitting element are EL elements.

According to an active matrix display device of the invention having the aforementioned structure, the monitor element and the light emitting element are formed of the same material.

According to an electronic device of the invention, the aforementioned active matrix display device is provided in a display portion.

A passive matrix display device of the invention includes a column signal line driver circuit which outputs a signal to a plurality of column signal lines provided in a column direction, a row signal line driver circuit which outputs a signal to a plurality of row signal lines provided in a row direction, and a pixel portion in which pixels are arranged in matrix corresponding to the column direction of the column signal line and the row direction of the row signal line. The pixel includes a light emitting element in which a layer containing an organic compound is sandwiched by a first electrode formed of a part of the column signal line and a second electrode formed of a part of the row signal line. The passive matrix display device further includes a monitor element provided beside the light emitting elements for each for of the pixels in a periphery of the pixel portion and in which a layer containing an organic compound is sandwiched by a first electrode formed of a part of the column signal line and a second electrode formed of a part of the row signal line, a current source which supplies a current to the monitor element, and an amplifier which inputs approximately the same potential as a potential of an anode of the monitor element to the column signal lines.

According to a passive matrix display device of the invention having the aforementioned structure, the amplifier is a voltage follower circuit.

According to a passive matrix display device of the invention having the aforementioned structure, the pixel is formed of a pixel with a plurality of color components, and the monitor element and the amplifier provided in a periphery of the pixel portion are provided for each pixel of the color component.

According to a passive matrix display device of the invention having the aforementioned structure, the monitor element and the light emitting element are EL elements.

According to a passive matrix display device of the invention having the aforementioned structure, the monitor element and the light emitting element are formed of the same material.

According to an electronic device of the invention, a passive matrix display device having the aforementioned structure is provided in a display portion thereof.

A display device of the invention includes a first heat dissipation layer over a first substrate, a pixel portion having a light emitting element of which resistance changes by a temperature change over the first heat dissipation layer, and a driver circuit provided in the periphery of the pixel portion. The pixel portion is sandwiched by the first substrate and a second substrate.

A display device of the invention includes a first heat dissipation layer over a first substrate, a pixel portion having a light emitting element of which resistance changes by a temperature change over the first heat dissipation layer, and a driver circuit formed of a thin film transistor provided in the periphery of the pixel portion. The pixel portion is sandwiched by the first substrate and a second substrate.

According to a display device of the invention having the aforementioned structure, the first heat dissipation layer has heat conductivity of 10 to 300 W/mK.

According to a display device of the invention having the aforementioned structure, the first heat dissipation layer contains aluminum nitride (AlN) or aluminum nitride oxide.

According to a display device of the invention having the aforementioned structure, the first heat dissipation layer contains aluminum nitride oxide (AlN_xO_y).

5

According to a display device of the invention having the aforementioned structure, aluminum nitride oxide contains 0.1 to 30 atomic % of oxygen (O).

According to a display device of the invention having the aforementioned structure, a second heat dissipation layer is formed over an external surface of the second substrate.

According to a display device of the invention, the second heat dissipation film is a metal film.

According to a display device of the invention having the aforementioned structure, the metal film is formed of a film containing copper.

According to an electronic device of the invention, a display device having the aforementioned structure is provided in a display portion.

A driving method of a display device of the invention including a pixel portion formed of a plurality of light emitting elements of which resistance changes by a temperature change is that when a temperature gradient occurs in the pixel portion, a low voltage is applied to a light emitting element of a high temperature while a high voltage is applied to a light emitting element of a low temperature.

The invention provides a display device having a light emitting element of which luminance variations due to a temperature change are reduced.

BRIEF DESCRIPTION OF THE DRAWINGS

FIG. 1 is a diagram showing an active matrix display device of the invention.

FIG. 2 is a diagram showing a specific configuration example of an active matrix display device of the invention.

FIG. 3 is a diagram showing a specific configuration example of an active matrix display device of the invention.

FIG. 4 is a diagram showing an active matrix display device of the invention.

FIG. 5 is a diagram showing a specific configuration example of an active matrix display device of the invention.

FIG. 6 is a diagram showing an active matrix display device of the invention.

FIG. 7 is a diagram showing an active matrix display device of the invention.

FIG. 8 is a diagram showing a specific configuration example of an active matrix display device of the invention.

FIG. 9 is a diagram showing a passive matrix display device of the invention.

FIG. 10 is a diagram showing a specific configuration example of a passive matrix display device of the invention.

FIG. 11 is a diagram showing a compensation function of an active matrix display device of the invention.

FIG. 12 is a diagram showing a compensation function of a passive matrix display device of the invention.

FIG. 13 is a diagram showing a temperature dependency of V-I characteristics of a light emitting element.

FIG. 14 is a diagram showing a change of V-I characteristics of a light emitting element with time.

FIGS. 15A and 15B are diagrams showing panel configurations of an active matrix display device of the invention.

FIGS. 16A and 16B are diagrams showing panel configurations of an active matrix display device of the invention.

FIGS. 17A and 17B are diagrams showing panel configurations of a passive matrix display device of the invention.

FIGS. 18A and 18B are diagrams showing panel configurations of a passive matrix display device of the invention.

FIG. 19 is a diagram showing a configuration of a light emitting element which can be applied to an active matrix display device of the invention.

6

FIG. 20 is a diagram showing a configuration of a light emitting element which can be applied to an active matrix display device of the invention.

FIG. 21 is a diagram showing a configuration of a light emitting element which can be applied to a passive matrix display device of the invention.

FIG. 22 is a diagram showing a configuration of a light emitting element which can be applied to a passive matrix display device of the invention.

FIG. 23 is a diagram showing a basic principle of a display device of the invention.

FIG. 24 is a diagram showing a temperature gradient in a pixel portion of a display device.

FIGS. 25A and 25B are examples of a pixel configuration which can be applied to an active matrix display device of the invention.

FIGS. 26A to 26H are views of electronic devices having display portions to which a display device of the invention can be applied.

DETAILED DESCRIPTION OF THE INVENTION

Although the invention will be fully described by way of Embodiment Modes with reference to the accompanying drawings, it is to be understood that various changes and modifications will be apparent to those skilled in the art. Therefore, unless otherwise such changes and modifications depart from the scope of the invention, they should be construed as being included therein.

FIG. 23 shows a schematic diagram of a display device of the invention. A display device of the invention includes a first signal line driver circuit 2301, a second signal line driver circuit 2302, and a pixel portion 2303. A plurality of light emitting elements 2307 are arranged in matrix in the pixel portion 2303. Here, the light emitting element 2307 has a characteristic that resistance decreases as a temperature rises. In this display device, the first signal line driver circuit 2301 operates at a higher frequency than the second signal line driver circuit 2302.

In the periphery of the pixel portion 2303, a monitor element group 2306 in which monitor elements 2305 are arranged in a column direction is provided. That is, the monitor elements 2305 are provided in a row direction of the light emitting elements 2307 of the pixel portion 2303. Further, a reference current source 2304 which supplies a constant current to each monitor element 2305 is provided.

An operation principle of a display device of the invention is briefly described. The reference current source 2304 supplies a constant current to the monitor element 2305. That is, a constant current drive is performed. As shown by an arrow in FIG. 23, a voltage generated in the monitor element 2305 is applied to a plurality of light emitting elements provided in a row direction of the monitor elements 2305. That is, a constant voltage drive is performed for the light emitting element 2307.

In this manner, a higher voltage can be applied to the light emitting element 2307 arranged further from the first signal line driver circuit 2301 which is a heat source due to a high frequency operation. In other words, a lower voltage can be applied to the light emitting element 2307 arranged nearer to the first signal line driver circuit 2301. Accordingly, luminance variations due to a temperature gradient in the pixel portion 2303 can be reduced.

Here, FIG. 24 shows a schematic diagram of a display device in the case of supplying a common voltage to light emitting elements in the display. The display device shown in FIG. 24 includes a first signal line driver circuit 2401, a

second signal line driver circuit **2402**, and a pixel portion **2403**. A plurality of light emitting elements **2404** are arranged in matrix in the pixel portion **2403**. Here, the light emitting element **2404** has a characteristic that resistance decreases as a temperature rises. In this display device, the first signal line driver circuit **2401** operates at a higher frequency than the second signal line driver circuit **2402**.

Here, as the first signal line driver circuit **2401** operates at a high frequency, a higher temperature is generated than the second signal line driver circuit **2402**. Then, a portion in the pixel portion **2403** near the first signal line driver circuit **2401** is brought to a high temperature while an effect of the heat generation becomes smaller at a further portion from the first signal line driver circuit **2401**. Then, the light emitting element **2404** in the pixel portion near the first signal line driver circuit **2401** is also brought to a high temperature, thereby resistance is decreased. On the other hand, in a pixel further from the first signal line driver circuit **2401**, resistance does not change much as an effect of the heat generation of the first signal line driver circuit **2401** is small.

At this time, by applying a common voltage to the light emitting elements **2404** of the pixel portion **2403**, the light emitting element **2404** in the pixel portion **2303** becomes brighter near the first signal line driver circuit **2401**. That is, a luminance becomes higher.

According to a display device of the invention, however, this display variation is reduced.

It is to be noted that the first signal line driver circuits **2301** and **2401** are the heat sources in FIGS. **23** and **24**, however, the invention is not limited to this. In the case where a connecting portion of an FPC to connect a panel of the display device and a module is a heat source, a higher voltage is applied to a light emitting element at a further place from the FPC connecting portion as the heat source.

[Embodiment Mode 1]

In this embodiment mode, the case of applying the invention to an active matrix display device is described. First, a basic principle of a temperature and deterioration compensation circuit (hereinafter simply referred to as a compensation circuit) included in the display device of the invention is described with reference to FIG. **11**.

FIG. **11** schematically shows an active display device. The display device includes a gate signal line driver circuit (also referred to as a gate driver) **1107**, a source signal line driver circuit (also referred to as a source driver) **1108**, and a pixel portion **1109**. The pixel portion **1109** is formed of a plurality of pixels **1106** each of which includes a driving transistor **1104** and a light emitting element **1105**. Further, the display device includes a reference current source **1101**, a monitor element **1102**, and an amplifier **1103**. The reference current source **1101** supplies a constant current to the monitor element **1102**. That is, the monitor element **1102** is driven by a constant current. Accordingly, a current value supplied to the monitor element **1102** is always constant. When a peripheral temperature (hereinafter referred to as an environment temperature) changes in this state, resistance of the monitor element **1102** changes. When the resistance of the monitor element **1102** changes, a potential difference between opposite electrodes of the monitor element **1102** changes as a current value supplied to the monitor element **1102** is constant. By detecting the potential difference between the opposite electrodes of the monitor element **1102**, a temperature change is detected. More specifically, a potential at an electrode of the monitor element **1102**, of which potential is maintained constant, namely a potential of a cathode **1110** in FIG. **1** does not

change, thus a potential change of an electrode connected to the current source **1101**, namely an anode **1111** in FIG. **1** is detected.

Here, an environment temperature dependency of V-I characteristics of the monitor element **1102** is described with reference to FIG. **13**. The V-I characteristics of the monitor element **1102** at a room temperature (for example, 25° C.), a low temperature (for example, -20° C.), and a high temperature (for example, 70° C.) are shown by lines **1301**, **1302**, and **1303** respectively. When a current value supplied from the reference current source **1101** to the monitor element **1102** is I_0 , a voltage V_0 is generated at the monitor element at a normal temperature. At a low temperature, a voltage of V_1 is generated while a voltage of V_2 is generated at a high temperature. That is, a voltage drop at the monitor element **1102** becomes V_0 when a current of the current value I_0 is supplied to the monitor element **1102** at a normal temperature, while a voltage drop at the monitor element of a low temperature becomes V_1 and a voltage drop at the monitor element of a high temperature becomes V_2 . Accordingly, temperature compensation can be performed by applying a voltage V_1 to the light emitting element **1105** when the temperature is low while applying a voltage V_2 thereto when the temperature is high.

FIG. **14** is a diagram showing a change of V-I characteristics of the monitor element **1102** with time. A line **1401** shows initial characteristics of the monitor element **1102** while a line **1402** shows characteristics after deterioration. It is to be noted that the initial characteristics and the characteristics after the deterioration are measured with the same temperature condition (normal temperature). When a current I_0 is supplied to the monitor element **1102** in the state of initial characteristics, a voltage of V_0 generates at the monitor element **1102** while a voltage of V_3 generates at the monitor element **1102** after deterioration. That is, in the case of applying a constant voltage to a light emitting element, a current value decreases with time. In other words, resistance of a light emitting element to which a current continues to be supplied becomes high as compared to the initial state that a current started to be supplied to the light emitting element. Accordingly, a current value supplied to the light emitting element decreases with time even though a constant voltage is applied thereto. Therefore, by applying a voltage V_3 to the light emitting element **1102** which is deteriorated similarly, an apparent deterioration of the light emitting element **1105** can be reduced.

Accordingly, a voltage set in consideration of data of these temperature change and change with time is applied to the light emitting element **1105**. That is, a voltage value is set according to a change in resistance of the light emitting element **1105** caused by the temperature change and change with time. In this manner, luminance variations of the light emitting element **1105** due to the temperature change and change with time are suppressed.

Here, the temperature of each light emitting element **1105** also differs depending on a place where the pixel **1106** is arranged in the pixel portion **1109**. For example, the source signal line driver circuit **1108** which operates at a high frequency is brought to a high temperature by generating heat. Accordingly, the light emitting element **1105** in the pixel **1106** arranged on the source signal line driver circuit **1108** side is brought to a high temperature as well. Therefore, a temperature gradient occurs in the pixel portion **1109** from the light emitting element **1105** arranged near the source signal line driver circuit **1108** to the light emitting element **1105** arranged far from it. When a common voltage is applied to the light emitting elements **1105** of all the pixels **1106** which form the pixel portion **1109**, luminance variations

occur. That is, a luminance of the light emitting element **1105** nearer to the source signal line driver circuit **1108** becomes higher while that of the light emitting element **1105** further from the source signal line driver circuit **1108** becomes lower.

In view of the aforementioned, according to the invention, a voltage suitable for the arrangement of the pixels in the pixel portion is applied to the light emitting elements for reducing luminance variations due to the temperature change of the light emitting element caused by the arrangement of the pixels. More preferably, in a display device including a plurality of pixels arranged in matrix corresponding to a plurality of source signal lines provided in a column direction and a plurality of gate signal lines provided in a row direction, a voltage to be applied is set for each row of light emitting elements in the pixel. The voltage is set by compensating an environment temperature and changes with time of each row of pixels.

A description is made with reference to FIG. 1 on a configuration example of an active display device in which a voltage which compensated the environment temperature and change with time of each row of pixels is set.

A display device includes a gate signal line driver circuit **105** which outputs a signal to gate signal lines G_1 to G_m provided in a row direction, a source signal line driver circuit **106** which outputs a signal to source signal lines S_1 to S_n provided in a column direction, and a pixel portion **107** in which a plurality of pixels **108** are arranged in matrix corresponding to the row direction and column direction. The pixel **108** includes a driving transistor **110** and a light emitting element **109** of which cathode is connected to GND. The driving transistor **110** is controlled to be turned on/off by a signal inputted from the source signal lines S_1 to S_n in a gate selection period. The light emitting element **109** emits light in the pixel **108** of which driving transistor **110** is on. It is to be noted that a row of pixels selected by the gate signal line G_1 is shown as a pixel group $111a_1$, a row of pixels selected by the gate signal line G_2 is shown as a pixel group $111a_2$, and a row of pixels selected by the gate signal line G_m is shown as a pixel group $111a_m$.

Further, a display device includes reference current sources $101a_1$ to $101a_m$, monitor elements $102a_1$ to $102a_m$, and amplifiers $103a_1$ to $103a_m$. Each of the monitor elements $102a_1$ to $102a_m$ has a cathode connected to GND similarly to the cathode of the light emitting element **109**. The reference current source $101a_1$ supplies a constant current to the monitor element $102a_1$, thereby a voltage generates at the monitor element $102a_1$. That is, a potential difference generates between opposite electrodes of the monitor element $102a_1$. A potential of an anode $104a_1$ of the monitor element $102a_1$ is detected by the amplifier $103a_1$ and then approximately the same voltage is outputted to a power source line V_1 . In this manner, the potential outputted from the amplifier $103a_1$ is inputted to an anode of the light emitting element **109** in the pixel **108** of which driving transistor **110** is on in the pixel group $111a_1$ which includes switching transistors of which gate electrodes are connected to the gate signal line G_1 . Accordingly, a current is supplied to the light emitting element **109** and it emits light. Similarly, the reference current sources $101a_2$ to $101a_m$ supplies a constant current to the monitor elements $102a_2$ to $102a_m$ respectively, the amplifiers $103a_2$ to $103a_m$ detects a potential of the anodes $104a_2$ to $104a_m$ of the monitor elements $102a_2$ to $102a_m$ and outputs approximately the same potential as the detected potential to the power source lines V_2 to V_m respectively. In this manner, a voltage can be set for each row of pixels such as the pixel groups $111a_1$, $111a_2$, $111a_3$, . . . , and $111a_m$, to be supplied to the light emitting elements **109** therein. It is to be noted that

approximately the same potential here may have a margin of error to the extent that luminance variations of the monitor element and the light emitting element cannot be recognized when a potential of the monitor element detected in each row is outputted to each power source line and applied to the light emitting elements of each row, with the monitor element and the light emitting element having the same V-I characteristics. Accordingly, approximately the same potential has a certain degree of margin.

It is to be noted that a voltage follower circuit using an operational amplifier can be applied to the amplifiers $103a_1$ to $103a_m$. A non-inverting input terminal of the voltage follower circuit is high in input impedance while an output terminal thereof is low in output impedance. Therefore, the output terminal of the voltage follower circuit can supply a current with a non-inverting input terminal thereof being supplied almost no current from the reference current sources $101a_2$ to $101a_m$. Then, the output terminal of the voltage follower circuit can output the same potential as a potential inputted to the non-inverting input terminal. That is, an impedance conversion can be carried out. Therefore, it is needless to say that any circuit which has such a function can be used as well as a voltage follower circuit. Further, an impedance conversion is not necessarily carried out when using an amplifier which outputs from an output terminal approximately the same voltage as a potential inputted to an input terminal. Accordingly, a voltage feedback amplifier and a current feedback amplifier can be appropriately used for the amplifiers $103a_1$ to $103a_m$.

Further, a cathode of the light emitting element **109** of each of the pixel **108** and the monitor elements $102a_1$ to $102a_m$ is connected to GND, however, the invention is not limited to this. For example, a cathode of each of the light emitting element **109** and the monitor elements $102a_1$ to $102a_m$ may be connected to another wiring having a specific potential. Further, cathodes of the monitor elements $102a_1$ to $102a_m$ and each light emitting element **109** may be connected to different wirings, or each cathode of the monitor elements $102a_1$ to $102a_m$ may be connected to different wirings or the same wiring. However, it is preferable that the cathodes of the monitor elements $102a_1$ to $102a_m$ and the light emitting element **109** of each pixel **108** be connected to a wiring of the same potential.

The monitor element $102a_1$ is provided beside the light emitting element **109** of the pixel group $111a_1$ in the periphery of the pixel portion while the monitor elements $102a_2$ to $102a_m$ are provided beside the light emitting elements **109** of the pixel groups $111a_2$ to $111a_m$ respectively in the periphery of the pixel portion. Accordingly, a voltage generated at a monitor element of which distance from the source signal line driver circuit **106** is approximately equal, that is a monitor element of which resistance change by the temperature change is approximately equal is applied to the light emitting element **109**. Accordingly, luminance variations caused by a temperature gradient in the pixel portion **107** due to heat generation of the source signal line driver circuit **106** can be reduced. It is to be noted that luminance variations caused by the environment temperature change and change with time can be reduced as well.

It is preferable to form the monitor element and the light emitting element using the same material over the same substrate at the same time. Accordingly, variations in V-I characteristics of the monitor element and the light emitting element can be reduced.

It is to be noted that one monitor element is provided for each row of the pixel portion in the configuration of FIG. 1, however, a plurality of monitor elements may be provided as

11

well. By providing a plurality of monitor elements for each row in parallel, variations in characteristics of the monitor element can be averaged.

[Embodiment Mode 2]

In this embodiment mode, a specific configuration example of an active display device described with reference to FIG. 1 is described with reference to FIG. 2.

A display device includes a gate signal line driver circuit **205** which outputs a signal to the gate signal lines G_1 to G_m provided in a row direction, a source signal line driver circuit **206** which outputs a signal to the source signal lines S_1 to S_n in a column direction, and a pixel portion **207** in which a plurality of pixels **208** are arranged in matrix corresponding to the gate signal lines G_1 to G_m and the source signal lines S_1 to S_n . The pixel **208** includes a switching transistor **204**, a driving transistor **210**, a capacitor **211**, and a light emitting element **209**.

Here, a DATA signal is inputted to the source signal line driver circuit **206** in serial. A SCK signal, a SCKB signal, and a SSP signal are inputted to a pulse output circuit **212** and signals are sequentially outputted to each column of a first latch circuit **213**. In accordance with the signals outputted from the pulse output circuit **212**, a DATA signal is stored in parallel in the first latch circuit **213**. When a SLAT signal is inputted to a second latch circuit **214**, the DATA signal stored in the first latch circuit **213** is transferred to the second latch circuit **214**. The DATA signal stored in the second latch circuit **214** is outputted from the source signal line driver circuit **206**. Further, a GCK signal, a GCKB signal, and a GSP signal are inputted to the gate signal line driver circuit **205**, which sequentially selects the gate signal lines G_1 to G_m . The switching transistor **204** is turned on, of which gate electrode is connected to the selected gate signal line. In a gate selection period. Then, the signal outputted from the source signal line driver circuit **206** is written to the capacitor **211** of the pixel **208** of the selected row through the source signal lines S_1 to S_n . In this manner, a charge of the signal from the source signal lines S_1 to S_n is accumulated in the capacitor **211**. The driving transistor **210** is controlled to be turned on/off by the accumulated charge. Then, the light emitting element **209** emits light in the pixel **208** of which driving transistor **210** is on.

Further, a display device includes reference current sources $201a_1$ to $201a_m$, monitor elements $202a_1$ to $202a_m$, and voltage follower circuits $203a_1$ to $203a_m$. Each of the monitor elements $202a_1$ to $202a_m$ and the light emitting element **209** has a cathode connected to GND. The reference current source $201a_1$ supplies a constant current to the monitor element $202a_1$, thereby a voltage generates at the monitor element $202a_1$. That is, a potential difference generates between opposite electrodes of the monitor element $202a_1$. A potential of an anode of the monitor element $202a_1$ is detected by the voltage follower circuit $203a_1$ and approximately the same potential is outputted to the power source line V_1 . In this manner, a signal is inputted from the source signal lines S_1 to S_n to a row of pixels which include switching transistors of which gate electrodes are connected to the gate signal line G_1 when the gate signal line G_1 is selected. Then, a potential outputted from the voltage follower circuit $203a_1$ is inputted to the light emitting element **209** of the pixel **208** of which driving transistor **210** is on. Accordingly, a current is supplied to the light emitting element **209** and it emits light. Similarly, the reference current sources $201a_2$ to $201a_m$ supplies a constant current to the monitor elements $202a_2$ to $202a_m$ respectively, the voltage follower circuits $203a_2$ to $203a_m$ detects a potential of the anodes of the monitor elements $202a_2$ to $202a_m$ and outputs approximately the same potential as the

12

detected potential to the power source lines V_2 to V_m respectively. In this manner, a voltage can be set for each row of pixels, to be supplied to the light emitting elements **209** therein. It is to be noted that approximately the same potential here may have a margin of error to the extent that luminance variations of the monitor element and the light emitting element cannot be recognized when a potential of the monitor element detected in each row is outputted to each power source line and applied to the light emitting elements of each row, with the monitor element and the light emitting element having the same V-I characteristics. Accordingly, approximately the same potential has a certain degree of margin.

Further, the monitor element $202a_1$ is provided in the periphery of the pixel portion beside the light emitting element **209** of the pixel **208** including a switching transistor **204**, of which gate electrode is connected to the gate signal line G_1 . Similarly, the monitor elements $202a_2$ to $202a_m$ are provided in the periphery of the pixel portion beside the light emitting element **209** of the pixel **208** including a switching transistor **204** of which gate electrode is connected to the gate signal lines G_2 to G_m respectively. Accordingly, approximately the same voltage as a voltage generated at a monitor element of which distance from the source signal line driver circuit **206** is approximately equal to the light emitting element, that is a monitor element of which resistance change by the temperature change is approximately equal is applied to the light emitting element **209**. Accordingly, luminance variations caused by a temperature gradient in the pixel portion **207** due to heat generation of the source signal line driver circuit **206** can be reduced. It is to be noted that luminance variations caused by the environment temperature change and change with time can be reduced as well.

Although the voltage follower circuits $203a_1$ to $203a_m$ are used in the configuration of FIG. 2, any circuit which has a function to output from an output terminal approximately the same potential as a potential inputted to an input terminal can be used as well as a voltage follower circuit. Accordingly, a voltage feedback amplifier and a current feedback amplifier can be appropriately used.

Although the cathodes of the monitor elements $202a_1$ to $202a_m$ and the light emitting element **209** of the each pixel **208** are connected to GND, the invention is not limited to this. For example, a cathode of each of the light emitting element **209** and the monitor elements $202a_1$ to $202a_m$ may be connected to another wiring having a specific potential. Further, cathodes of the monitor elements $202a_1$ to $202a_m$ and each light emitting element **209** may be connected to different wirings, or each cathode of the monitor elements $202a_1$ to $202a_m$ may be connected to different wirings or the same wiring. However, it is preferable that the cathodes of the monitor elements $202a_1$ to $202a_m$ and the light emitting element **209** of each pixel **208** be connected to a wiring of the same potential.

Further, the invention is not limited to this configuration, and can be applied to a pixel configuration in which polarity of a transistor in the pixel is changed, a connection is changed, or a new transistor is additionally provided.

Further, a monitor element may be provided on the opposite side to the gate signal line driver circuit with the pixel portion interposed therebetween. The arrangement of the monitor element can be appropriately selected for achieving an effective function of temperature compensation.

FIG. 3 shows a different configuration than that of the display device of FIG. 2. In the configuration of FIG. 3, the power source lines V_1 to V_m , can be provided outside the pixel portion.

A display device shown in FIG. 3 includes a gate signal line driver circuit 305 which outputs a signal to the gate signal lines G_1 to G_m provided in a row direction, a source signal line driver circuit 306 which outputs a signal to the source signal lines S_1 to S_n provided in a column direction, and a pixel portion 307 in which a plurality of pixels 308 are arranged in matrix corresponding to the row direction and the column direction. The pixel 308 includes a switching transistor 304, a driving transistor 310, a capacitor 311, and a light emitting element 309. Further, the display device shown in FIG. 3 includes reference current sources $301a_1$ to $301a_m$, monitor elements $302a_1$ to $302a_m$, and voltage follower circuits $303a_1$ to $303a_m$. Here, in the display device shown in FIG. 3, the reference current sources $301a_1$ to $301a_m$, the monitor elements $302a_1$ to $302a_m$, the voltage follower circuits $303a_1$ to $303a_m$, the gate signal line driver circuit 305, the source signal line driver circuit 306, and the pixel portion 307 correspond to the reference current sources $201a_1$ to $201a_m$, the monitor elements $202a_1$ to $202a_m$, the voltage follower circuits $203a_1$ to $203a_m$, the gate signal line driver circuit 205, the source signal line driver circuit 206, and the pixel portion 207 in the display device shown in FIG. 2. The operation thereof is similar to that of FIG. 2, therefore, the description thereof is omitted here.

It is to be noted that a potential is outputted from the voltage follower circuits $303a_1$ to $303a_m$, therefore, when a voltage drop occurs due to wiring resistance of a wiring between output terminals of the voltage follower circuits $303a_1$ to $303a_m$ and each pixel 308, a voltage value applied to the light emitting element 309 in each pixel 308 varies. Then, luminance of a pixel varies. In view of this, it is preferable to lower wiring resistance of wirings between output terminals of the voltage follower circuits $303a_1$ to $303a_m$ to each pixel 308. Accordingly, luminance variations of each pixel 308 can be reduced by providing the power source lines V_1 to V_m outside the pixel portion and forming the power source lines V_1 to V_m using a low resistant material as in this configuration. However, when there are more pixel rows, lead wirings between the driving transistor 310 and the power source lines V_1 to V_m are increased, which leads to lower the aperture ratio of the pixels. Therefore, it is preferable to use the configurations shown in FIGS. 2 and 3 appropriately. Further, for example, the configuration shown in FIG. 3 may be employed for upper rows and lower rows of the pixel portion 307 while the configuration shown in FIG. 2 is employed for the other part.

Although the voltage follower circuits $303a_1$ to $303a_m$ are used in the configuration of FIG. 3, it is needless to say that the invention is not limited to the voltage follower circuit as long as a function to output from an output terminal approximately the same potential as a potential inputted to an input terminal is provided. Accordingly, a voltage feedback amplifier and a current feedback amplifier can be appropriately used for the voltage follower circuits $303a_1$ to $303a_m$.

Although the cathodes of the monitor elements $302a_1$ to $302a_m$ and the light emitting element 309 of the each pixel 308 are connected to GND, the invention is not limited to this. For example, a cathode of each of the light emitting element 309 and the monitor elements $302a_1$ to $302a_m$ may be connected to another wiring having a specific potential. Further, cathodes of the monitor elements $302a_1$ to $302a_m$ and each light emitting element 309 may be connected to different wirings, or each cathode of the monitor elements $302a_1$ to $302a_m$ may be connected to different wirings or the same wiring. However, it is preferable that the cathodes of the monitor elements $302a_1$ to $302a_m$ and the light emitting element 309 be connected to a wiring of the same potential.

Further, the invention is not limited to this configuration, and can be applied to a pixel configuration in which polarity of a transistor in the pixel is changed, a connection is changed, or a new transistor is additionally provided.

Further, a monitor element may be provided on the opposite side to the gate signal line driver circuit with the pixel portion interposed therebetween. The arrangement of the monitor element can be appropriately selected for achieving an effective function of temperature compensation.

[Embodiment Mode 3]

In this embodiment mode, a configuration of a display device is described including a gate signal line driver circuit 405 which outputs a signal to the gate signal lines G_1 to G_m provided in a row direction, a source signal line driver circuit 406 which outputs a signal to the source signal line driver circuits S_1 to S_n provided in a column direction, and a pixel portion 407 in which a plurality of pixels 408 are arranged in matrix corresponding to the gate signal lines G_1 to G_m and the source signal lines S_1 to S_n . In the display device, a voltage value applied to the light emitting element 409 is set per group of a plurality of rows of the pixels. That is, a voltage value is set per row of the pixels in the configuration of FIG. 1, however, a voltage value is set by two rows of pixels in the configuration of FIG. 4.

A display device shown in FIG. 4 includes a gate signal line driver circuit 405 which outputs a signal to the gate signal lines G_1 to G_m provided in a row direction, a source signal line driver circuit 406 which outputs a signal to the source signal lines S_1 to S_n provided in a column direction, and a pixel portion 407 in which a plurality of pixels 408 are arranged in matrix corresponding to the row direction and the column direction. The pixel 408 includes a driving transistor 410 and a light emitting element 409 of which cathode is connected to GND. The driving transistor 410 is controlled to be turned on/off by a signal inputted from the source signal lines in a gate selection period. The light emitting element 409 emits light in the pixel 408 of which driving transistor 410 is on. It is to be noted that a row of pixels selected by the gate signal line G_1 is denoted as a pixel group $411a_1$, a row of pixels selected by the gate signal line G_2 is denoted as a pixel group $411a_2$, and a row of pixels selected by the signal line G_m is denoted as a pixel group $411a_m$.

The display device further includes reference current sources $401a_1$ to $401a_{m/2}$, monitor elements $402a_1$ to $402a_m$, and amplifiers $403a_1$ to $403a_{m/2}$. The cathodes of the monitor elements $402a_1$ to $402a_m$ are connected to GND similarly to the cathode of the light emitting element 409. The reference current source $401a_1$ supplies a constant current to the monitor elements $402a_1$ and $402a_2$, thereby a voltage is generated at the monitor elements $402a_1$ and $402a_2$. That is, a potential difference generates between opposite electrodes of the monitor elements $402a_1$ and $402a_2$. Potentials at anodes $404a_1$ and $404a_2$ of the monitor elements $402a_1$ and $402a_2$ are detected by the amplifier $403a_1$ and approximately the same potential is outputted to the power source line V_1 . In this manner, a potential outputted from the amplifier $403a_1$ is inputted to the light emitting element 409 in the pixel 408 of which driving transistor 410 is on among the pixel group $411a_1$ having switching transistors of which gate electrodes are connected to the gate signal line G_1 or the pixel group $411a_2$ having switching transistors of which gate electrodes are connected to the gate signal line G_2 . Accordingly, a current is supplied to the light emitting element 409 and it emits light. Similarly, each of the reference current sources $401a_2$ to $401a_{m/2}$ supplies a constant current to the monitor elements $402a_3$, $402a_4$ to $402a_{m-1}$ and $402a_m$, each of the amplifiers $403a_2$ to $403a_{m/2}$ detects a potential of anodes $404a_3$, $404a_4$ to

404a_{m-1}, and 404a_m of the monitor elements 402a₃, 402a₄ to 402a_{m-1} and 402a_m respectively, and approximately the same potentials are outputted to the power source lines V₂ to V_{m/2}. In this manner, a voltage applied to the light emitting element 409 can be set by two rows of pixel groups, such as the pixel groups 411a₁ and 411a₂, 411a₃ and 411a₄, 411a_{m-1} and 411a_m. That is, a voltage value corresponding to an averaged value of resistances of two monitor elements is detected and applied to the light emitting element. Further, as a power source line is shared for two rows of pixels, the number of power source lines and lead wirings of the driving transistor 410 can be reduced. Accordingly, variations in characteristics of the monitor element can be averaged and the aperture ratio of a pixel can be improved. It is to be noted that approximately the same potential here may have a margin of error to the extent that luminance variations of the monitor element and the light emitting element cannot be recognized when a potential of the monitor element detected in each row is outputted to each power source line and applied to the light emitting elements of each row, with the monitor element and the light emitting element having the same V-I characteristics. Accordingly, approximately the same potential has a certain degree of margin.

In the configuration of FIG. 4, a power source line is shared for two rows of pixels, however, the invention is not limited to this. The power source line can be appropriately controlled so as to reduce the luminance variations due to a temperature gradient of the pixel portion. For example, two power source lines may be provided by dividing the pixel portion into the upper portion and the lower portion at a half of the pixel rows. A power source line may be additionally provided for a pixel row which is particularly easily affected by heat generation of the source signal line driver circuit 406, that is a few rows of pixels near the source signal line driver circuit 406.

It is to be noted that a voltage follower circuit using an operational amplifier can be applied to the amplifiers 403a₁ to 403a_{m/2}. A non-inverting input terminal of the voltage follower circuit is high in input impedance while an output terminal thereof is low in output impedance. Therefore, the output terminal of the voltage follower circuit can supply a current with a non-inverting input terminal thereof being supplied almost no current from the reference current sources 401a₂ to 401a_{m/2}. Then, the output terminal of the voltage follower circuit can output the same potential as a potential inputted to the non-inverting input terminal. That is, an impedance conversion can be carried out. Therefore, it is needless to say that any circuit which has such a function can be used as well as a voltage follower circuit. Further, an impedance conversion is not necessarily carried out when using an amplifier which outputs from an output terminal approximately the same voltage as a potential inputted to an input terminal. Accordingly, a voltage feedback amplifier and a current feedback amplifier can be appropriately used for the amplifiers 403a₁ to 403a_{m/2}.

Further, a cathode of the light emitting element 409 of each of the pixel 408 and the monitor elements 402a₁ to 402a_m is connected to GND, however, the invention is not limited to this. For example, a cathode of each of the light emitting element 409 and the monitor elements 402a₁ to 402a_m may be connected to another wiring having a specific potential. Further, cathodes of the monitor elements 402a₁ to 402a_m, and each light emitting element 409 may be connected to different wirings, or each cathode of the monitor elements 402a₁ to 402a_m may be connected to different wirings or the same wiring. However, it is preferable that the cathodes of the

monitor elements 402a₁ to 402a_m and the light emitting element 409 of each pixel 408 be connected to a wiring of the same potential.

In the configuration of FIG. 4, a power source wiring is shared for a plurality of rows of pixels of the display device having a configuration shown in FIG. 1, however, the invention can be applied to a configuration in which a power source line is provided outside the pixel portion as shown in the configuration of FIG. 3. A specific example of a configuration of such a display device is shown in FIG. 5.

A display device includes a gate signal line driver circuit 505 which outputs a signal to the gate signal lines G₁ to G_m provided in a row direction, a source signal line driver circuit 506 which outputs a signal to the source signal lines S₁ to S_n provided in a column direction, and a pixel portion 507 in which a plurality of pixels 508 are arranged in matrix corresponding to the gate signal lines G₁ to G_m and the source signal lines S₁ to S_n. The pixel 508 includes a driving transistor 510 and a light emitting element 509 of which cathode is connected to GND. Further, the source signal line driver circuit 505 includes a pulse output circuit 512, a first latch circuit 513, and a second latch circuit 514. The driving transistor 510 is controlled to be turned on/off by a signal inputted from the source signal line in a gate selection period. The light emitting element 509 emits light in the pixel 508 of which driving transistor 510 is on.

Further, the display device includes reference current sources 501a₁ to 501a_{m/2}, monitor elements 502a₁ to 502a_m, and amplifiers 503a₁ to 503a_{m/2}. The cathodes of the monitor elements 502a₁ to 502a_m are connected to GND similarly to the cathode of the light emitting element 509. In this configuration, the reference current source 501a₁ supplies a current to the monitor elements 502a₁ and 502a₂. The amplifier 503a₁ detects potentials of anodes of these monitor elements, thereby a potential is set at the power source line V₁.

In this configuration, the power source lines V₁ to V_{m/2} are provided outside the display portion 507, and the number of lead wirings of source electrodes of the driving transistors 510 can be reduced, which can improve the aperture ratio of a pixel.

Although the voltage follower circuits 503a₁ to 503a_{m/2} are used in the configuration of FIG. 5, it is needless to say that the invention is not limited to the voltage follower circuit as long as a function to output from an output terminal approximately the same potential as a potential inputted to an input terminal is provided. Accordingly, a voltage feedback amplifier and a current feedback amplifier can be appropriately used for the voltage follower circuits 503a₁ to 503a_{m/2}.

Although the cathodes of the monitor elements 502a₁ to 502a_m and the light emitting element 509 of the each pixel 508 are connected to GND, the invention is not limited to this. For example, a cathode of each of the light emitting element 509 and the monitor elements 502a₁ to 502a_m may be connected to another wiring having a specific potential. Further, cathodes of the monitor elements 502a₁ to 502a_m, and each light emitting element 509 may be connected to different wirings, or each cathode of the monitor elements 502a₁ to 502a_m may be connected to different wirings or the same wiring. However, it is preferable that the cathodes of the monitor elements 502a₁ to 502a_m, and the light emitting element 509 be connected to a wiring of the same potential.

Further, the invention is not limited to this configuration, and can be applied to a pixel configuration in which polarity of a transistor in the pixel is changed, a connection is changed, or a new transistor is additionally provided.

Further, a monitor element may be provided on the opposite side to the gate signal line driver circuit with the pixel

portion interposed therebetween. The arrangement of the monitor element can be appropriately selected for achieving an effective function of temperature compensation.

[Embodiment Mode 4]

In this embodiment mode, a display device which includes a plurality of color components and has a compensation function for each pixel of the color component is described. For example, a display device which has a compensation function for each pixel of RGB is described with reference to FIG. 6. It is to be noted that color components of R (red), G (green), and B (blue) which form one pixel are referred to as a pixel of R, a pixel of G, and a pixel of B respectively.

The display device includes a gate signal line driver circuit **605** which outputs a signal to the gate signal lines G_1 to G_m provided in a row direction, a source signal line driver circuit **606** which outputs a signal to source signal lines Sr_1, Sg_1, Sb_1 to Sr_m, Sg_m, Sb_m provided in a column direction, and a pixel portion **607** in which a plurality of pixels **608** formed of a pixel of R **608r**, a pixel of G **608g**, and a pixel of B **608b** are arranged in matrix corresponding to the gate signal lines G_1 to G_m and the source signal lines S_1 to S_m . Each of the pixel of R **608r**, the pixel of G **608g**, and the pixel of B **608b** includes a driving transistor **610** and a light emitting element **609** of which cathode is connected to GND. The driving transistor **610** is controlled to be turned on/off by a signal inputted from the source signal lines Sr_1, Sg_1, Sb_1 to Sr_m, Sg_m, Sb_m in a gate selection period. The light emitting element **609** emits light in the pixel **608** of which driving transistor **610** is turned on. It is to be noted that a row of pixels selected by the gate signal line G_1 is denoted as a pixel group **604a₁**, a row of pixels selected by the gate signal line G_2 is denoted as a pixel group **604a₂**, a row of pixels selected by the signal line G_3 is denoted as a pixel group **604a₃**, and a row of pixels selected by the signal line G_m is denoted as a pixel group **604a_m**.

The display device further includes reference current sources **601r₁** to **601r_m**, reference current sources **601g₁** to **601g_m**, reference current sources **601b₁** to **601b_m**, monitor elements **602r₁** to **602r_m**, monitor elements **602g₁** to **602g_m**, monitor elements **602b₁** to **602b_m**, amplifiers **603r₁** to **603r_m**, amplifiers **603g₁** to **603g_m**, and amplifiers **603b₁** to **603b_m**. The cathodes of the monitor elements **602r₁** to **602r_m**, **602g₁** to **602g_m**, and **602b₁** to **602b_m** are connected to GND similarly to the cathode of the light emitting element **609**. The reference current source **601r₁** supplies a constant current to the monitor element **602r₁**, thereby a voltage generates at the monitor element **602r₁**. That is, a potential difference generates between opposite electrodes of the monitor element **602r₁**. A potential of an anode of the monitor element **602r₁** at this time is detected by the amplifier **603r₁** and approximately the same potential is outputted to a power source line Vr_1 . Similarly, the reference current sources **601r₂** to **601r_m**, the reference current sources **601g₂** to **601g_m**, and the reference current sources **601b₂** to **601b_m**, supply a constant current to the monitor elements **602r₂** to **602r_m**, **602g₂** to **602g_m**, and **602b₂** to **602b_m** respectively. The amplifiers **603r₂** to **603r_m** detect potentials of anodes of the monitor elements **602r₂** to **602r_m**, the amplifiers **603g₂** to **603g_m** detect potentials of anodes of the monitor elements **602g₂** to **602g_m**, and the amplifiers **603b₂** to **603b_m**, detect potentials of anodes of the monitor elements **602b₂** to **602b_m** respectively, thereby approximately the same potentials are outputted to power source lines Vr_2 to Vr_m, Vg_2 to Vg_m, Vb_2 to Vb_m respectively. It is to be noted that approximately the same potential here may have a margin of error to the extent that luminance variations of the monitor element and the light emitting element cannot be recognized when a potential of the monitor element detected in each row is outputted to each power source line and applied to the light

emitting elements of each row, with the monitor element and the light emitting element having the same V-I characteristics. Accordingly, approximately the same potential has a certain degree of margin.

In the pixel group **604a₁**, the power source line Vr_1 supplies a voltage to a light emitting element in the pixel of R, the power source line Vg_1 supplies a voltage to a light emitting element in the pixel of G, and the power source line Vb_1 supplies a voltage to a light emitting element in the pixel of B. Similarly, in the pixel groups **604a₂** to **604a_m**, the power source lines Vr_2 to Vr_m supply a voltage to the light emitting element in the pixel of R, the power source lines Vg_2 to Vg_m supply a voltage to the light emitting element in the pixel of G, and the power source lines Vb_2 to Vb_m supply a voltage to the light emitting element in the pixel of B, respectively.

In this manner, a voltage generated at a monitor element arranged for each row of pixels is detected and applied to a light emitting element in the row of pixels, thereby luminance variations due to a temperature gradient in the pixel portion caused by heat generation of the source signal line driver circuit **606** can be reduced.

As a temperature change and a change with time are compensated by providing a monitor element for each pixel of RGB in a row of pixels, a voltage value can be set for a light emitting element according to the characteristics of each of RGB. That is, luminance variations among pixels of RGB can be compensated.

It is to be noted that the invention can be applied to a display device in which pixels of RGB are provided in a delta configuration. With a pixel in delta configuration, a high quality display device can be provided.

A voltage follower circuit using an operational amplifier can be applied to amplifiers **603r₁** to **604r_m**, **603g₁** to **603g_m**, and **603b₁** to **603b_m**. A non-inverting input terminal of the voltage follower circuit is high in input impedance while an output terminal thereof is low in output impedance. Therefore, the output terminal of the voltage follower circuit can supply a current with a non-inverting input terminal thereof being supplied almost no current from the reference current sources **601a₂** to **601a_m**. Then, the output terminal of the voltage follower circuit can output the same potential as a potential inputted to the non-inverting input terminal. That is, an impedance conversion can be carried out. Therefore, it is needless to say that any circuit which has such a function can be used as well as a voltage follower circuit. Further, an impedance conversion is not necessarily carried out when using an amplifier which outputs from an output terminal approximately the same voltage as a potential inputted to an input terminal. Accordingly, a voltage feedback amplifier and a current feedback amplifier can be appropriately used for the amplifiers **603r₁** to **603r_m**, **603g₁** to **603g_m**, and **603b₁** to **603b_m**.

Further, a cathode of the light emitting element **609** of each of the pixel **608** and the monitor elements **602r₁** to **602r_m**, **602g₁** to **602g_m**, and **602b₁** to **602b_m** is connected to GND, however, the invention is not limited to this. For example, a cathode of each of the light emitting element **609** and the monitor elements **602r₁** to **602r_m**, **602g₁** to **602g_m**, and **602b₁** to **602b_m** may be connected to another wiring having a specific potential. Further, cathodes of the monitor elements **602a₁** to **602a_m** and each light emitting element **609** may be connected to different wirings, or each cathode of the monitor elements **602r₁** to **602r_m**, **602g₁** to **602g_m**, and **602b₁** to **602b_m** may be connected to different wirings or the same wiring. However, it is preferable that the cathodes of the monitor elements **602r₁** to **602r_m**, **602g₁** to **602g_m**, and **602b₁** to **602b_m**

and the light emitting element **609** of each pixel **608** be connected to a wiring of the same potential.

[Embodiment Mode 5]

In this embodiment mode, description is made on a configuration of FIG. 7 in which the number of reference current sources which supply a current to a monitor element in the configuration of FIG. 1 is reduced.

A display device includes a gate signal line driver circuit **705** which outputs a signal to the gate signal lines G_1 to G_m provided in a row direction, a source signal line driver circuit **706** which outputs a signal to the source signal lines S_1 to S_n provided in a column direction, and a pixel portion **707** in which a plurality of pixels **708** are arranged in matrix corresponding to the gate signal lines G_1 to G_m and the source signal lines S_1 to S_n . The pixel **708** includes a driving transistor **710** and a light emitting element **709** of which cathode is connected to GND. The driving transistor **710** is controlled to be turned on/off by a signal inputted from the source signal lines in a gate selection period. The light emitting element **709** emits light in the pixel **708** of which driving transistor **710** is on. It is to be noted that a row of pixels selected by the gate signal line G_1 is denoted as a pixel group $711a_1$, a row of pixels selected by the gate signal line G_2 is denoted as a pixel group $711a_2$, and a row of pixels selected by the signal line G_m is denoted as a pixel group $711a_m$.

The display device further includes a reference current source **701**, monitor elements $702a_1$ to $702a_m$, and amplifiers $703a_1$ to $703a_m$. The cathodes of the monitor elements $702a_1$ to $702a_m$ are connected to GND similarly to the cathode of the light emitting element **709**. That is, an amplifier which supplies a voltage to the power source lines V_1 to V_m for each row of pixels connected to the gate signal lines G_1 to G_m is provided. Each of the amplifiers detects a potential of an anode $704a_1$ of the monitor element arranged for each row of pixels, thereby approximately the same potential is set at a power source line. It is to be noted that approximately the same potential here may have a margin of error to the extent that luminance variations of the monitor element and the light emitting element cannot be recognized when a potential of the monitor element detected in each row is outputted to each power source line and applied to the light emitting elements of each row, with the monitor element and the light emitting element having the same V-I characteristics. Accordingly, approximately the same potential has a certain degree of margin.

Here, a principle is described that one reference current source **701** is used for supplying the same value of current to each of the monitor elements $702a_1$ to $702a_m$ provided in each of the pixel groups $711a_1$ to $711a_m$ and a voltage generated at each monitor element is detected by the amplifiers $703a_1$ to $703a_m$ provided for each row of pixels.

First, switches $713a_1$ and $714a_1$ are turned on for setting a potential at the power source line V_1 of the pixel group $711a_1$ selected by the gate signal line G_1 . Then, a current from the reference current source **701** flows to a capacitor $712a_1$ and the monitor element $702a_1$. A charge corresponding to a voltage generated at the monitor element $702a_1$ is accumulated in the capacitor $712a_1$, thus a current stops flowing to the capacitor $712a_1$. Then, a potential of an anode of the capacitor $712a_1$ is detected by the amplifier $703a_1$. Here, a potential of the anode of the capacitor $712a_1$ is set at the same potential as that of the cathode of the monitor element, therefore, a voltage generated at the monitor element $702a_1$ can be detected by detecting a potential of an anode of the capacitor $712a_1$ having the same potential as that of an anode $714a_1$ of the monitor element $702a_1$.

Note that when the switches $713a_1$ and $714a_1$ are turned on, the switches $713a_2$ to $713a_m$ and $714a_2$ to $714a_m$ are turned off. When the switches $713a_2$ and $714a_2$ are turned on, the switches $713a_1$, $713a_3$ to $713a_m$, $714a_1$, and $714a_3$ to $714a_m$ are turned off. Accordingly, a current can be sequentially supplied from the reference current source **701** to the monitor elements $702a_1$ to $702a_m$ provided beside each row $711a_1$ to $711a_m$ of pixels. Further, in the case where a current is not supplied to the corresponding monitor element, a capacitor which accumulates a charge corresponding to a voltage of each monitor element can hold a voltage generated when a current is supplied thereto.

A voltage follower circuit using an operational amplifier can be applied to amplifiers $703a_1$ to $703a_m$. A non-inverting input terminal of the voltage follower circuit is high in input impedance while an output terminal thereof is low in output impedance. Therefore, the output terminal of the voltage follower circuit can supply a current with a non-inverting input terminal thereof being supplied almost no current from the reference current sources $701a_2$ to $701a_m$. Then, the output terminal of the voltage follower circuit can output the same potential as a potential inputted to the non-inverting input terminal. That is, an impedance conversion can be carried out. Therefore, it is needless to say that any circuit which has such a function can be used as well as a voltage follower circuit. Further, an impedance conversion is not necessarily carried out when using an amplifier which outputs from an output terminal approximately the same voltage as a potential inputted to an input terminal. Accordingly, a voltage feedback amplifier and a current feedback amplifier can be appropriately used for the amplifiers $703a_1$ to $703a_m$.

Further, a cathode of the light emitting element **709** of each of the pixel **708** and the monitor elements $702a_1$ to $702a_m$, and one electrode of each of the capacitors $712a_1$ to $712a_m$ is connected to GND, however, the invention is not limited to this. For example, a cathode of each of the light emitting element **709** and the monitor elements $702a_1$ to $702a_m$ and one electrode of each of the capacitors $712a_1$ to $712a_m$ may be connected to another wiring having a specific potential. Further, cathodes of the monitor elements $702a_1$ to $702a_m$ and each light emitting element **709** and one electrode of each of the capacitors $712a_1$ to $712a_m$ may be connected to different wirings, or each cathode of the monitor elements $702a_1$ to $702a_m$ may be connected to different wirings or the same wiring. However, it is preferable that the cathodes of the monitor elements $702a_1$ to $702a_m$ and the light emitting element **709** of each pixel **708** and the one electrode of each of the capacitors $712a_1$ to $712a_m$ be connected to a wiring of the same potential.

Next, a specific configuration example of the display device shown in FIG. 7 is described with reference to FIG. 8.

A display device includes a gate signal line driver circuit **805** which outputs a signal to gate signal lines G_1 to G_m provided in a row direction, a source signal line driver circuit **806** which outputs a signal to source signal lines S_1 to S_n provided in a column direction, and a pixel portion **807** in which a plurality of pixels **808** are arranged in matrix corresponding to the gate signal lines G_1 to G_m and the source signal lines S_1 to S_n . The pixel **808** includes a switching transistor **804**, a capacitor **811**, a driving transistor **810**, and a light emitting element **809** of which cathode is connected to GND.

The display device further includes a reference current source **801**, a monitor element **802** corresponding to each row of pixels, a voltage follower circuit **803**, a capacitor **812**, a first transistor **813** and a second transistor **814**. The gate electrodes of the first transistor **813** and the second transistor **814** are

connected to a gate signal line. Therefore, at a timing that the switching transistor **804** of which gate electrode is connected to a gate signal line selected by the gate signal line driver circuit **805** is turned on, the first and second transistors **813** and **814** provided corresponding to a row of pixels including the switching transistor are turned on. That is, the first and second transistors **813** and **814** provided corresponding to a row of pixels in a state (in a gate selection period) where a signal from the source signal lines S_1 to S_m can be written to the driving transistor **810**. Accordingly, the first and second transistors **813** and **814** corresponding to each row of pixels are sequentially turned on according to a signal from the gate signal lines G_1 to G_m .

When the first and second transistors **813** and **814** are turned on, a current from the reference current source **801** flows to the capacitor **812** and the monitor element **802**. A charge corresponding to a voltage generated at the monitor element **802** is accumulated in the capacitor **812**, thus a current stops flowing to the capacitor **812** and only flows to the monitor element **802**. At this time, a potential of an anode of the monitor element **802** is inputted to a non-inverting input terminal of the voltage follower circuit **803** and an output terminal thereof outputs approximately the same potential to a power source line of a corresponding row of pixels. It is to be noted that approximately the same potential here may have a margin of error to the extent that luminance variations of the monitor element and the light emitting element cannot be recognized when a potential of the monitor element detected in each row is outputted to each power source line and applied to the light emitting elements of each row, with the monitor element and the light emitting element having the same V-I characteristics. Accordingly, approximately the same potential has a certain degree of margin.

When a gate selection period of a certain row of pixels is terminated and a gate selection period of a next row of pixels starts, the first transistor **813** and the second transistor **814** are turned off which correspond to the row of pixels of which gate selection period is terminated, and then a voltage generated at the monitor element **802** at that time is held in the capacitor **812**. By each capacitor **812** sequentially holding a voltage generated at the monitor element **802** corresponding to each row of pixels, a potential of an anode of the corresponding monitor element **802** can be inputted to a non-inverting input terminal of the voltage follower circuit **803** corresponding to each row of pixels. Accordingly, approximately the same potential as a potential of an anode of each monitor element **802** for each row of pixels is set at each power source line. When a gate selection period starts again in each row, the capacitor **812** accumulates a charge corresponding to a voltage generated by a change in resistance of the monitor element **802** caused by an environment temperature change and a change with time, and holds a voltage of the monitor element **802** at a moment when the gate selection period is terminated.

In this manner, in the display device having the configuration of FIG. 8, luminance variations of a light emitting element caused by a temperature change and a change with time can be compensated according to a gate selection period.

Further, luminance variations of the light emitting element **809** caused by a temperature gradient due to heat generation of the source signal line driver circuit **806** can be compensated by setting a potential of a power source line for each row of pixels.

Moreover, only one current source is required to be provided because of a simple configuration. Thus, a circuit configuration can be simplified and cost reduction can be realized.

Although the voltage follower circuit **803** is used in the configuration of FIG. 8, it is needless to say that the invention is not limited to the voltage follower circuit as long as a function to output from an output terminal approximately the same potential as a potential inputted to an input terminal is provided. Accordingly, a voltage feedback amplifier and a current feedback amplifier can be appropriately used for the voltage follower circuit.

Although the cathodes of the monitor element **802** and the light emitting element **809** of each pixel **808** are connected to GND, the invention is not limited to this. For example, a cathode of each of the light emitting element **809** and the monitor elements **802** may be connected to another wiring having a specific potential. Further, cathodes of the monitor elements **802** and each light emitting element **809** may be connected to different wirings, or each cathode of the monitor elements **802** may be connected to different wirings or the same wiring. However, it is preferable that the cathodes of the monitor elements **802** and the light emitting elements **809** be connected to a wiring of the same potential. Further, the invention is not limited to this configuration, and can be applied to a pixel configuration in which polarity of a transistor in the pixel is changed, a connection is changed, or a new transistor is additionally provided.

Further, a monitor element may be provided on the opposite side to the gate signal line driver circuit with the pixel portion interposed therebetween. The arrangement of the monitor element can be appropriately selected for achieving an effective function of temperature compensation.

[Embodiment Mode 6]

An active matrix display device (also referred to as an active display device) is described in Embodiment Modes 1 to 5, however, the invention can be applied to a passive matrix display device (also referred to as a passive display device) as well. In this embodiment mode, the case of applying a compensation circuit of the invention to a passive matrix display device is described.

A basic principle of a temperature and deterioration compensation circuit (hereinafter simply referred to as a compensation circuit) included in a passive display device and a driving method of the display device are briefly described with reference to FIG. 12.

A display device shown in FIG. 12 includes a row signal line driver circuit **1202** which outputs a signal to row signal lines R_1 to R_m provided in a row direction, a column signal line driver circuit **1201** which outputs a signal to column signal lines C_1 to C_n provided in a column direction, and a pixel portion **1203** in which light emitting elements **1208** are arranged in matrix corresponding to the row signal lines R_1 to R_m and the column signal lines C_1 to C_n . The row signal line driver circuit **1202** selects one row signal line among the row signal lines R_1 to R_m (here, a row signal line is connected to GND). That is, one row signal line is selected so that a current is supplied to the light emitting element **1208** by a potential difference between a potential set at the column signal lines C_1 to C_n . Thus, a potential difference between a potential at the selected row signal line and a potential set at the column signal line is applied to the light emitting element **1208** sandwiched by the row signal line and the column signal line. Then, a current flows and the light emitting element **1208** emits light. At this time, a potential at the column signal lines C_1 to C_n is set similarly at each column signal line, however, a period in which a potential is set differs. In this manner, a time gray scale display can be performed.

The display device further includes a reference current source **1205**, a monitor element **1207**, and an amplifier **1204**. The reference current source **1205** supplies a constant current

to the monitor element **1207**. That is, the monitor element **1207** performs a constant current drive. The amplifier **1204** detects a potential on an anode **1206** side of the monitor element **1207**, thereby a potential outputted to the column signal lines C_1 to C_n is set. It is to be noted that a voltage follower circuit, for example, can be used as the amplifier **1204**.

The column signal line driver circuit **1201** includes a pulse output circuit **1209**, a first latch circuit **1210**, a second latch circuit **1211**, and a switch group **1212**. A pulse is outputted from the pulse output circuit **1209**, based on which a DATA signal is sequentially stored in the first latch circuit **1210**. The data stored in the first latch circuit **1210** is transferred to the second latch circuit **1211** at a timing of a SLAT signal. Then, the data stored in the second latch circuit **1211** controls a period in which each switch in the switch group **1212** is turned on, thereby a period in which a potential is supplied to the column signal lines C_1 to C_n is set. That is, a period in which a potential is applied to the light emitting element is determined. In this manner, a time gray scale display can be performed.

It is to be noted in actuality that, in the case of a 3-bit gray scale display, for example, to each of the first latch circuit **1210** and the second latch circuit **1211** includes three latch circuits per switch which controls a power supply of each column signal line. The 3-bit data per each column signal line outputted from the second latch circuit **1211** is converted to have a pulse width for displaying an 8-level gray scale so that each switch of the switch group **1212** is turned on in a period corresponding to the pulse width. In this manner, the 8-level gray scale can be displayed.

Here, the display device of the invention includes a monitor element arranged in the periphery of the pixel portion beside the light emitting element provided in a row direction. A unit for supplying a constant current to each monitor element, detecting a voltage generated at the monitor element, and applying the voltage to the light emitting element provided in the row direction is provided. An example of such a passive display device is described with reference to FIG. 9.

A display device shown in FIG. 9 includes a row signal line driver circuit **902** which outputs a signal to the row signal lines (also referred to as scan lines) R_1 to R_m provided in a row direction, a column signal line driver circuit **901** which outputs a signal to the column signal lines C_1 to C_n provided in a column direction, and a pixel portion **903** in which light emitting elements **908** are arranged in matrix corresponding to the row signal lines R_1 to R_m and the column signal lines C_1 to C_n . It is to be noted that a row of light emitting elements of which cathodes are connected to the row signal line R_1 is denoted as a light emitting element group **906a₁**, a row of light emitting elements of which cathodes are connected to the row signal line R_2 is denoted as a light emitting element group **906a₂**, and a row of light emitting elements of which cathodes are connected to the row signal line R_m is denoted as a light emitting element group **906a_m**.

The display device shown in FIG. 9 includes a reference current source **905**, an amplifier **904**, and monitor elements **907a₁** to **907a_m**. The reference current source **905** supplies a constant current to any of the monitor elements **907a₁** to **907a_m**. In this configuration, a cathode of each monitor element corresponding to a light emitting group provided in a row direction is connected to a row signal line similarly to a cathode of the light emitting element **908**, therefore, a current only flows to a monitor element corresponding to a light emitting element group in a scan line selection period. That is,

a current flows to the light emitting element **908** and the monitor element in a row of which row signal line is connected to GND.

A voltage generated at a monitor element to which a current is supplied is detected by the amplifier **904**, thus the voltage is inputted to the column signal line driver circuit **901**. Then, the column signal line driver circuit **901** sets a period in which a voltage inputted from the amplifier **904** is supplied to each of the column signal lines C_1 to C_n is set. That is, a period in which a voltage is supplied is set for each column of a certain row of light emitting element group. Then, a voltage applied to each column of light emitting elements is the same voltage as a voltage supplied by the amplifier **904**.

In this manner, a constant current is supplied to a monitor element provided for each row of light emitting elements, and a generated voltage is applied to the light emitting element **908** of the same row. That is, a constant current is supplied from the reference current source **905** to the monitor element **907a₁**, a generated voltage is applied to the light emitting element group **906a₁**, a constant current is supplied from the reference current source **905** to the monitor element **907a₂**, a generated voltage is applied to the light emitting element group **906a₂**, a constant current is supplied from the reference current source **905** to the monitor element **907a_m**, and a generated voltage is applied to the light emitting element group **906a_m**.

In this manner, a voltage generated at a monitor element provided beside each row of light emitting elements is detected, and the detected voltage is applied to the light emitting element of that row, thereby luminance variations due to a temperature gradient in the pixel portion caused by heat generation of the column signal line driver circuit **901** can be reduced.

A voltage can be set in accordance with a resistance of the light emitting element **908** which changes due to an environment temperature change and a change with time. Therefore, the environment temperature change and change with time can be compensated as well.

It is to be noted that a voltage follower circuit using an operational amplifier can be applied to the amplifier **904**. A non-inverting input terminal of the voltage follower circuit is high in input impedance while an output terminal thereof is low in output impedance. Therefore, the output terminal of the voltage follower circuit can supply a current with a non-inverting input terminal thereof being supplied almost no current from the reference current source **905**. Then, the output terminal of the voltage follower circuit can output the same potential as a potential inputted to the non-inverting input terminal. That is, an impedance conversion can be carried out. Therefore, it is needless to say that any circuit which has such a function can be used as well as a voltage follower circuit. Further, an impedance conversion is not necessarily carried out when using an amplifier which outputs from an output terminal approximately the same voltage as a potential inputted to an input terminal. Accordingly, a voltage feedback amplifier and a current feedback amplifier can be appropriately used for the amplifier **904**.

Further, a potential at a row signal line when selected is GND, however, the invention is not limited to this. Therefore, the wiring may have a specific potential other than GND.

Next, a specific configuration example in which a monitor element is provided for each light emitting element of RGB for setting a voltage for each light emitting element of RGB is described with reference to FIG. 10.

A display device shown in FIG. 10 includes a row signal line driver circuit **1002** which outputs a signal to row signal lines (also referred to as scan lines) R_1 to R_m provided in a row

direction, a column signal line driver circuit **1001** which outputs a signal to the column signal lines C_1 to C_n provided in a column direction, and a pixel portion **1003** in which light emitting elements are arranged in matrix corresponding to the row signal lines R_1 to R_m and the column signal lines C_1 to C_n .

A light emitting element **1008r** of an R component, a light emitting element **1008g** of a G component, and a light emitting element **1008b** of a B component are arranged in the order of RGB in a column direction corresponding to column signal lines. In the periphery of the pixel portion **1003**, a monitor element group **1006r** of an R component, a monitor element group **1006g** of a G component, and a monitor element group **1006b** of a B component are provided beside the column of light emitting elements of RGB. The monitor elements which form these monitor element groups are provided beside the light emitting elements provided in a row direction corresponding to the row signal lines R_1 to R_m .

The display device further includes a reference current source **1005r** which supplies a current to monitor elements which form the monitor element group **1006r**, a reference current source **1005g** which supplies a current to a monitor element which forms the monitor element group **1006g**, a reference current source **1005b** which supplies a current to monitor elements which form the monitor element group **1006b**, an amplifier **1004r** which detects a potential of an anode of monitor elements which form the monitor element group **1006r** and sets at a power source line Vr approximately the same potential as the detected potential, an amplifier **1004g** which detects a potential of an anode of a monitor element which forms the monitor element group **1006g** and sets at a power source line Vg approximately the same potential as the detected potential, and an amplifier **1004b** which detects a potential of an anode of the monitor elements which form the monitor element group **1006b** and sets at a power source line Vb approximately the same potential as the detected potential. It is to be noted that approximately the same potential here may have a margin of error to the extent that luminance variations of the monitor element and the light emitting element cannot be recognized when a potential of the monitor element detected in each row is outputted to each power source line and applied to the light emitting elements of each row, with the monitor element and the light emitting element having the same V-I characteristics. Accordingly, approximately the same potential has a certain degree of margin.

Further, the column signal line driver circuit includes a pulse output circuit **1009**, a first latch circuit **1010**, and a second latch circuit **1011**. It is to be noted that an operation of the column signal line driver circuit **1001** is omitted here as it is similar to that described with reference to FIG. 12.

In this configuration, for example, when the row signal line R_1 is selected, the reference current source **1005r** supplies a current to the monitor element **1008r** of which cathode is connected to a row signal line among monitor elements which form the monitor element group **1006r**. Then, a current flows through the monitor element **1008r**, a potential of an anode of the monitor element **1008r** at which a voltage is generated is detected by the amplifier **1004r**, and approximately the same potential as the detected potential is set at the power source line Vr. The potential set at the power source line Vr is supplied as a voltage through column signal lines Cr_1 to Cr_n to the light emitting element **1008r** of which cathode is connected to the selected signal line R_1 . Similarly, the reference current source **1005g** supplies a current to the monitor element **1008g** of which cathode is connected to a row signal line among monitor elements which form the monitor element group **1006g**. Then, a current flows through the monitor element

1008g, a potential of an anode of the monitor element **1008g** at which a voltage is generated is detected by the amplifier **1004g**, and approximately the same potential as the detected potential is set at the power source line Vg. The potential set at the power source line Vg is supplied as a voltage through column signal lines Cg_1 to Cg_n to the light emitting element **1008g** of which cathode is connected to the selected signal line R_1 . The reference current source **1005b** supplies a current to the monitor element **1008b** of which cathode is connected to a row signal line among monitor elements which form the monitor element group **1006b**. Then, a current flows through the monitor element **1008b**, a potential of an anode of the monitor element **1008b** at which a voltage is generated is detected by the amplifier **1004b**, and approximately the same potential as the detected potential is set at the power source line Vb. The potential set at the power source line Vb is supplied as a voltage through column signal lines Cb_1 to Cb_n to the light emitting element **1008b** of which cathode is connected to the selected signal line R_1 . It is to be noted that approximately the same potential here may have a margin of error to the extent that luminance variations of the monitor element and the light emitting element cannot be recognized when a potential of the monitor element detected in each row is outputted to each power source line and applied to the light emitting elements of each row, with the monitor element and the light emitting element having the same V-I characteristics. Accordingly, approximately the same potential has a certain degree of margin.

In this manner, a voltage can be independently applied to each light emitting element of RGB provided in a row direction corresponding to the row signal line R_1 .

Next, when the row signal lines R_2, R_3, \dots, R_m are selected, a constant current is supplied to each monitor element of RGB corresponding to the selected row, a voltage generated at the monitor element of RGB in each row is detected by an amplifier corresponding to each RGB, and the voltage is supplied to each light emitting element of RGB of the corresponding row.

In this manner, a voltage generated at a monitor element provided beside each row of pixels is detected and applied to light emitting elements of the row of pixels, thereby luminance variations caused by a temperature gradient in a pixel portion due to heat generation of the source signal line driver circuit **606** can be reduced.

As an environment temperature change and a change with time are compensated by providing a monitor element for each pixel of RGB in a row of pixels, a voltage value can be set for a light emitting element according to the characteristics of each of RGB. That is, luminance variations among pixels of RGB can be compensated.

Although the voltage follower circuits **1004r**, **1004g**, and **1004b** are used in the configuration of FIG. 8, it is needless to say that the invention is not limited to the voltage follower circuit as long as a function to output from an output terminal approximately the same potential as a potential inputted to an input terminal is provided. Accordingly, a voltage feedback amplifier and a current feedback amplifier can be appropriately used for the voltage follower circuits **1004r**, **1004g**, and **1004b**.

[Embodiment Mode 7]

In this embodiment mode, description is made on a panel configuration of a display device in which a temperature gradient in a pixel portion caused by heat generation of a signal line driver circuit is reduced.

In this embodiment mode, a heat dissipation layer for reducing a temperature gradient in a pixel portion of a display device is provided.

That is, a display device includes a display portion having a light emitting element of which luminance changes by a temperature change and a driver circuit provided in the periphery of the display portion over a first substrate with a first heat dissipation layer interposed therebetween. The display portion is sandwiched by the first substrate and a second substrate.

First, description is made with reference to FIGS. 15A and 15B on an example of a panel configuration in which a layer having a heat dissipation function is provided as a base film over a substrate surface on which a pixel portion is formed. It is to be noted that FIG. 15A is a top plan view of a display device and FIG. 15B is a cross-sectional view taken along A-A'-A" in FIG. 15A. As shown by dotted lines, the display device includes a driver circuit portion (source signal line driver circuit) 1501, a pixel portion 1502, a monitor element portion 1503, and a driver circuit portion (gate signal line driver circuit) 1504. Further, there is a space 1507 surrounded by a sealing substrate (opposite substrate) 1505 and a sealing material 1506.

It is to be noted that a wiring 1509 is a wiring for transferring a signal to be inputted to the source signal line driver circuit 1501 and the gate signal line driver circuit 1504, and receives a video signal, a clock signal, a start signal, a reset signal and the like from an FPC (Flexible Printed Circuit) 1510 as an external input terminal. An IC chip (semiconductor integrated circuit) 1511 is connected on the FPC by COG (Chip On Glass). It is to be noted that the IC chip may be connected by using TAB (Tape Auto Bonding) or a printed substrate.

The cross-sectional structure is described with reference to FIG. 15B. A base film 1526 having a heat dissipation effect is formed as a heat dissipation layer over the substrate 1508. It is preferable that the base film 1526 having a heat dissipation effect have a heat conductivity of 10 to 300 W/mK, and more preferably 50 to 300 W/mK. Further, the base film can be formed of alumina (Al_2O_3), cubic boron nitride (c-BN), aluminum nitride (AlN), BeO (beryllia), diamond and the like which are high in heat conductivity. In particular, aluminum nitride (AlN) is superior in heat conductivity, insulation performance, and high frequency characteristics, and is favorable as a heat dissipation layer since a thermal expansion coefficient close to that of silicon is obtained. For example, a single layer of MN (aluminum nitride), stacked layers of MN, SiNO (silicon nitride oxide), SiON (silicon oxynitride) and the like are preferably used. It is to be noted that aluminum nitride (AlN) may contain 0.1 to 30 atomic % of oxygen (O). That is, aluminum nitride oxide (AlN_xO_y) may be used as well.

The source signal line driver circuit 1501, the pixel portion 1502, the monitor element portion 1503, and the gate signal line driver circuit 1504 are formed over the base film 1526.

It is to be noted that the source signal line driver circuit 1501 is formed of a CMOS circuit in which an n-channel TFT 1512 and a p-channel TFT 1513 are used in combination. A TFT 1524 corresponds to a TFT which forms the gate signal line driver circuit. Further, a TFT which forms a driver circuit may be formed of a known CMOS circuit, PMOS circuit, or NMOS circuit. In this embodiment mode, a driver-integrated type is shown in which a driver circuit is formed over a substrate, however, the invention is not limited to this and the driver circuit can be formed outside the substrate as well.

The pixel portion 1502 is formed of a plurality of pixels each of which includes a switching TFT 1514 a current controlling TFT 1515 and a first electrode 1516 electrically connected to a drain of the current controlling TFT 1515. It is to be noted that an insulator 1517 is formed so as to cover an

edge portion of the first electrode 1516. Here, the insulator is formed using a positive type, photosensitive acrylic resin film.

In order to obtain a favorable coverage, the insulator 1517 is formed so as to have a curved surface with a curvature at a top portion or a bottom portion thereof. In the case of using a positive type, photosensitive acryl as a material for the insulator 1517, for example, it is preferable that a top portion only has a curved surface with a curvature radius (0.2 to 3 μm). As the insulator 1517, either of a negative type acryl which becomes insoluble to etchant by photosensitive light or a positive type acryl which becomes soluble to etchant by light can be used.

An electroluminescent layer 1518 and a second electrode 1519 are formed over the first electrode 1516. Here, it is preferable to use a material having a high work function for a material of the first electrode 1516 which functions as an anode. For example, a single layer structure of a titanium film, a chromium film, a tungsten film, a Zn film, a Pt film and the like, a stacked-layer structure of titanium nitride and a film containing aluminum as a main component, and a three-layer structure of a titanium nitride film, a film containing aluminum as a main component, and a titanium nitride film can be used. It is to be noted that a stacked-layer structure is low in resistance as a wiring, thus a favorable ohmic contact can be obtained and a function as an anode can be obtained as well.

Further, the electroluminescent layer 1518 is formed by a deposition method using a deposition mask or a ink-jet method. A metal complex which belongs to a group 4 of periodic table of elements is used for a part of the electroluminescent layer 1518. Besides, a low molecular weight material or a high molecular weight material can be used in combination. As a material used for the electroluminescent layer, an organic compound is often used in a single layer or stacked layers, however, an inorganic compound may be used for a part of a film formed of an organic compound in this embodiment mode. Moreover, a known triplet material may be used as well.

As a material of the second electrode 1519 formed over the electroluminescent layer 1518, a material having a low work function (Al, Ag, Li, Ca, or an alloy of these such as MgAg, MgIn, AlLi, CaF_2 , or CaN) may be used. It is to be noted that a top emission type is employed here, therefore, it is preferable to employ an aluminum film with a thickness of 1 to 10 nm, an aluminum film containing a slight amount of Li, or stacked layers of a thin metal film of which thickness is thinned, and a light-transmissive conductive film (ITO (indium oxide tin oxide alloy), indium oxide zinc oxide alloy ($\text{In}_2\text{O}_3\text{—ZnO}$), zinc oxide (ZnO) and the like).

In the pixel portion 1502, a wiring 1521 formed of the same material as the current controlling TFT 1515 and the first electrode 1516 electrically connected to a drain thereof, and a monitor element 1523 with a structure that the electroluminescent layer 1518 is sandwiched by a second electrode 1519 and an anode 1522 connected to the wiring 1521 are formed. It is to be noted that a light shielding film 1524 is formed over the monitor element portion 1503 for shielding light emission of the monitor element.

Further, by attaching the sealing substrate 1505 to the element substrate 1508 with the sealing material 1506, an electroluminescence element 1520 and the monitor element 1523 are provided in the space 1507 surrounded by the element substrate 1508, the sealing substrate 1505, and the sealing material 1506. It is to be noted that the space 1507 may be filled with the sealing material 1506 as well as an inert gas (nitrogen, argon and the like).

It is preferable that the sealing material **1506** be an epoxy based resin. Moreover, it is preferable that this material does not transmit moisture and oxygen as much as possible. As a material for the sealing substrate **1505**, a glass substrate, a quartz substrate, and a plastic substrate formed of FRP (Fiberglass-Reinforced Plastics), PVF (Polyvinyl Fluoride), mylar, polyester, acryl and the like can be used.

In this manner, an active matrix display device in which a temperature gradient in a pixel portion is reduced can be obtained.

Further, as another configuration for reducing a temperature gradient in the display portion, in a display device including a display portion provided with a light emitting element of which luminance changes by a temperature change and a driver circuit provided in the periphery of the display portion formed over a first substrate, in which the display portion is sandwiched by the first substrate and the second substrate, a layer having a heat dissipation effect may be provided over an outer surface of the second substrate.

Here, a configuration of a panel in the case of providing a layer having a heat dissipation effect over a counter substrate is described with reference to FIGS. **16A** and **16B**. It is to be noted that common portions between FIGS. **15** and **16** are denoted by common reference numerals and a description thereon is omitted here.

In this configuration, a film **1601** having a heat dissipation effect is formed over the sealing substrate **1505** to be a counter substrate. For example, a metal film which is superior in heat conductivity is preferably provided. As the metal film, for example, copper formed over a film by spin coating can be used. It is to be noted that a single layer of a layer having a heat dissipation effect or stacked layers of this film and silicon nitride oxide or silicon oxynitride may be used, however, stacked layers of only silicon nitride oxide and silicon oxynitride may be used in the configuration of FIGS. **16A** and **16B**. However, it is preferable for effectively dissipating heat to employ stacked layers of aluminum nitride (AlN) or diamond having a heat transmissivity, silicon nitride oxide, and silicon oxynitride. It is to be noted that aluminum nitride (AlN) may contain 0.1 to 30 atomic % of oxygen (O). That is, aluminum nitride oxide (AlN_xO_y) may be formed as well.

In the configuration of the panel shown in FIGS. **16A** and **16B**, it is preferable to employ a material having a high work function for a material of the first electrode **1516** which functions as an anode. For example, a light transmissive film such as an ITO (indium tin oxide) film and an indium zinc oxide (IZO) film can be used. By using a light transmissive film having a light transmissivity, an anode which can transmit light can be formed.

Further, for a material used for the second electrode **1519** which functions as a cathode, a metal film formed of a material having a low work function (Al, Ag, Li, Ca, or an alloy of these such as MgAg, MgIn, AlLi, CaF₂, or CaN) can be used. In this manner, by using a metal film which reflects light, a cathode which does not transmit light can be formed.

In this manner, light emitted from the light emitting element can be obtained downwards as shown by an arrow in FIG. **16B**.

It is to be noted that a substrate having a light transmissivity is used for the substrate **1508** in the case of using a light emitting element with a bottom emission structure to a display device.

In the case of providing an optical film, it may be provided over the substrate **1508**.

It is to be noted that a panel of a display device with a top emission structure is shown in FIG. **15** and a bottom emission

structure is shown in FIGS. **16A** and **16B**, however, it is needless to say that a dual emission structure may also be employed.

A light emitting element with a dual emission structure which can be applied to a display device of the invention is described with reference to FIG. **19**.

A base film **1905** is formed over a substrate **1900**, and then a current controlling TFT **1901** is formed thereover. Over the aforementioned, a first electrode **1902** is formed in contact with a drain electrode of the current controlling TFT **1901**, then a layer **1903** containing an organic compound and a second electrode **1904** are formed in this order. It is to be noted that a single layer of a layer having a heat dissipation effect or stacked layers of silicon nitride oxide and silicon oxynitride may be used for the base film **1905**. As the film having a heat dissipation effect, aluminum nitride, diamond and the like each having a light transmissivity can be used. It is to be noted that aluminum nitride (AlN) may contain 0.1 to 30 atomic % of oxygen (O). That is, aluminum nitride oxide (AlN_xO_y) may be formed as well.

The first electrode **1902** is an anode of the light emitting element while the second electrode **1904** is a cathode thereof. That is, a portion where the layer **1903** containing an organic compound is sandwiched by the first and second electrodes **1902** and **1904** corresponds to a light emitting element.

Here, it is preferable to use a material having a high work function for a material used for the first electrode **1902** which functions as an anode. For example, a light transmissive conductive film such as an ITO (indium tin oxide) film and an indium zinc oxide (IZO) film can be used. By using a light transmissive conductive film having a light transmissivity, an anode which can transmit light can be formed.

As a material used for the second electrode **1904** which functions as a cathode, it is preferable to use stacked layers of a thin metal film formed of a material having a low work function (Al, Ag, Li, Ca, or an alloy of these such as MgAg, MgIn, AlLi, CaF₂, or CaN), and a light transmissive conductive film (an ITO (indium tin oxide) film, an indium oxide zinc oxide (In₂O₃-ZnO), zinc oxide (ZnO) and the like). In this manner, a cathode which can transmit light can be formed by using a thin metal film and a light transmissive conductive film having a light transmissivity.

In this manner, light from a light emitting element can be extracted from both surfaces as shown by arrows in FIG. **19**. That is, in the case of applying the invention to the panel of the display device shown in FIG. **15**, light is emitted to the substrate **1508** side and the sealing substrate **1505** side. Therefore, in the case of using a dual emission structure light emitting element to a display device, a substrate having a light transmissivity is used for the substrate **1508** and the sealing substrate **1505**. Further, in the case of providing an optical film, the optical film may be provided for both the substrate **1508** and the sealing substrate **1505**.

The invention can also be applied to a display device which performs a full color display by using a light emitting element which emits white light and a color filter.

As shown in FIG. **20**, a base film **2002** is formed over a substrate **2000** and then a current controlling TFT **2001** is formed thereover. Over the aforementioned, a first electrode **2003** is formed in contact with a drain electrode of the current controlling TFT **2001**, and a layer **2004** containing an organic compound and a second electrode **2005** are formed in this order. It is to be noted that the base film **2002** may be formed of a material such as alumina (Al₂O₃), cubic boron nitride (c-BN), aluminum nitride (AlN), BeO (beryllia), diamond and the like which are high in heat conductivity. A single layer of the aforementioned or stacked layers with a silicon nitride

oxide film and a silicon oxynitride film can be used. It is to be noted that aluminum nitride (AlN) may contain 0.1 to 30 atomic % of oxygen (O). That is, aluminum nitride oxide (AlN_xO_y) may be formed as well.

The first electrode **2003** is an anode of the light emitting element while the second electrode **2005** is a cathode thereof. That is, a portion where a layer **2004** containing an organic compound is sandwiched by the first and second electrodes **2003** and **2005** corresponds to a light emitting element. In the configuration of FIG. **20**, the light emitting element emits white light. A red color filter **2006**, a green color filter **2006G**, and a blue color filter **2006B** are provided over the light emitting element, thereby a full color display can be performed. Further, a black matrix (also referred to as a BM) **2007** is provided for separating the color filters.

As only a light emitting element which emits white light is provided in the pixel portion in the configuration of FIG. **20**, a compensation function can be performed more accurately by forming a monitor element using a similar material to that of the light emitting element to obtain similar element characteristics.

Next, an example of a panel configuration of a passive display device is described with reference to FIGS. **17A** and **17B**. FIG. **17A** shows a top plan view of a display device while FIG. **17B** shows a cross-sectional view taken along B-B'-B'' in FIG. **17A**. As shown by dotted lines, the display device includes a driver circuit portion (source signal line driver circuit) **1701**, a pixel portion **1702**, a monitor element portion **1703**, and a driver circuit portion (row signal line driver circuit) **1704**. Further, there is a space **1707** surrounded by a sealing substrate **1705** and a sealing material **1706**.

It is to be noted that a wiring **1709** is a wiring for transferring a signal inputted to the column signal line driver circuit **1701** and the row signal line driver circuit **1704** and receives a video signal, a clock signal, a start signal and the like from an FPC (Flexible Printed Circuit) **1710** to be an external input terminal. Further, an IC chip (semiconductor integrated circuit) **1711** is connected by COG (Chip On Glass) on the FPC. It is to be noted that the IC chip may be connected by TAB (Tape Auto Bonding) and by using a printed substrate.

The cross-sectional structure is described with reference to FIG. **17B**. A base film **1721** having a heat dissipation effect is formed. The base film can be formed of, for example, a single layer of MN (aluminum nitride), or stacked layers of MN, SiNO (silicon nitride oxide), SiON (silicon oxynitride) and the like are preferably used. MN has a high heat conductivity, superior soaking characteristics of a temperature of the display and heat dissipation characteristics.

The pixel portion **1702** and the monitor element portion **1703** are formed over the base film **1721**. Then, the column signal line driver circuit portion **1701** and the row signal line driver circuit portion **1704** are formed in an IC chip which is connected to the substrate **1708** by COG (Chip On Glass).

The base film **1721** is formed over the substrate **1708** and then a column signal line formed of stacked layers is formed thereover. A bottom layer **1712** is a metal film having a reflecting property while a top layer **1713** is a light transmissive conductive oxide film. The top layer **1713** is preferably formed by using a conductive film having a high work function, such as a film formed of a light transmissive conductive material such as indium tin oxide (ITO), IZO (indium zinc oxide) obtained by mixing indium tin oxide containing a Si element (ITSO) and indium oxide with 2 to 20% of zinc oxide (ZnO), or a film containing a compound including these materials in combination. Among the aforementioned, ITSO remains in an amorphous state without being crystallized even when baked while ITO does not. Therefore, ITSO is

suitable for being used as an anode of a light emitting element for it has a higher planarity than ITO and does not have a short-circuit with a cathode even when the layer containing an organic compound is thin.

For the bottom layer **1712**, Ag, Al, or an Al (C+Ni) alloy film is used. In particular, an Al (C+Ni) film (an aluminum alloy film containing carbon and nickel (1 to 20 wt %)) is a preferable material as contact resistance with ITO and ITSO does not vary much even after current application or heat treatment.

A partition **1718** for insulating adjacent column signal lines is formed of a black resin, which functions as a black matrix (BM) which overlaps a boundary or a gap between different colored layers (provided on a sealing substrate side). A region surrounded by a black partition has the same area as a light emitting region.

The layer **1714** containing an organic compound has an HIL (hole injecting layer), an HTL (hole transporting layer), an EML (light emitting layer), an ETL (electron transporting layer), and an EIL (electron injecting layer) stacked in this order from the column signal line (anode) side. It is to be noted that a single layer structure or a mixed-layer structure can be employed as well as a stacked-layer structure for the layer containing an organic compound.

The row signal line (cathode) **1715** is formed so as to cross the column signal line (anode). In this manner, a light emitting element **1716** and a monitor element **1717** are formed in a region where the layer **1715** containing an organic compound is sandwiched by the column signal line and the row signal line. The row signal line (cathode) **1715** is formed of a light transmissive conductive film such as ITO, indium tin oxide containing a Si element (ITSO), and IZO obtained by mixing zinc oxide (ZnO) into indium oxide by 2 to 20%. In the configuration of this embodiment mode employing a top emission type display device in which light emission passes through the sealing substrate **1705** as shown by an arrow, it is important that the row signal line **1715** transmits light. It is to be noted that a partition **1719** for insulating adjacent row signal lines is formed by controlling the level of exposure and development time according to a photolithography method using a positive photosensitive resin with an unexposed portion as a pattern, so that a portion under the pattern is more etched.

Further, in order to protect a light emitting element from a damage from moisture and degasification, a light transmissive protect film covering the row signal line **1715** may be provided. As the light transmissive protect film, a dense inorganic insulating film (SiN, SiNO film and the like) formed by a PCVD method, a dense inorganic insulating film (SiN, SiNO film and the like) formed by a sputtering method, a thin film containing carbon as a main component (a DLC film, a CN film, and an amorphous carbon film), a metal oxide film (WO₂, CaF₂, Al₂O₃, and the like) and the like are preferably used. To be light transmissive means to have 80 to 100% of transmissivity of visible light.

A light shielding film **1720** is provided over the monitor element portion **1703** so that light emitted from the monitor element portion **1703** does not leak outside.

The pixel portion **1702** including a light emitting element is sealed by a sealing material **1706** and a sealing substrate **1705**, thereby a space **1707** which is surrounded is sealed and closed.

As the sealing material **1706**, an ultraviolet curable resin, a thermal curable resin, a silicone resin, an epoxy resin, an acrylic resin, a polyimide resin, a phenol resin, a PVC (polyvinyl chloride), PVB (polyvinyl butyral) or EVA (ethylene

vinyl acetate) can be used. The sealing material may be added a filler (a stick shape or fiber type spacer) or a spherical spacer.

Further, a glass substrate or a plastic substrate is used for the sealing substrate **1705**. As the plastic substrate, polyimide, polyamide, an acrylic resin, an epoxy resin, PES (Polyether Sulfone), PC (polycarbonate), PET (polyethylene terephthalate), or PEN (polyethylene naphthalate) can be used in a board or a film.

On the other hand, a terminal electrode is formed at an edge portion of the substrate **1708**, to which the FPC (Flexible Printed Circuit) **1710** connected to an external circuit is attached. The terminal electrode is formed of stacked layers of the metal film **1713** having reflecting property and the light transmissive conductive oxide film **1714**, however, the invention is not limited to this.

In the periphery of the pixel portion, IC chips **1701**, **1704**, and **1711** in which a driver circuit which transfers each signal to the pixel portion or the like is formed are electrically connected by an anisotropic conductive material **1721**. Further, in order to form the pixel portion corresponding to a color display, 3072 column signal lines and 768 row signal line are required in an XGA display. The column signal lines and row signal lines formed in these numbers are divided at an edge portion of the pixel portion and provided with leading out wirings, thereby the leading out wirings are gathered according to a pitch of output terminals of the IC chips.

The display device described above is a top emission type display device of which black partitions **1718** and **1719** contribute to improve the contrast.

A configuration of a panel in the case of providing a layer having a heat dissipation effect for a counter substrate is described with reference to FIGS. **18A** and **18B**. It is to be noted that common portions between FIGS. **17** and **18** are denoted by common reference numerals and a description thereon is omitted here.

In this configuration, a film **1801** having a heat dissipation effect is provided over the sealing substrate **1705** as a counter substrate. For example, a metal film superior in heat conductivity is preferably used. As the metal film, for example, a copper film formed by spin coating can be used. It is to be noted that a single layer of a layer having a heat dissipation effect or stacked layers of this film, silicon nitride oxide and silicon oxynitride may be used. As the layer having a heat dissipation effect here, aluminum nitride, diamond and the like having a light transmissivity can be used. It is to be noted that aluminum nitride (AlN) may contain 0.1 to 30 atomic % of oxygen (O). That is, aluminum nitride oxide (AlN_xO_y) may be formed as well.

The light emitting element with a bottom emission structure is formed of the column signal line (anode) **1713** formed of a light transmissive conductive oxide film, the layer **1714** containing an organic compound, and the row signal line **1715** formed of a conductive film having a reflecting property. Further, the partition **1718** is formed of a material having a light transmissivity.

The light emitted from the light emitting element is extracted in a direction shown by an arrow in FIG. **18B**, that is a direction to pass through the substrate **1708**. Therefore, the sealing substrate **1705** is not particularly required to have a light transmissivity, but a metal board may be used as well. This structure is preferable because the efficiency of light extraction is not decreased even when a thick protective film is formed for improving reliability of the light emitting element.

In the case of providing an optical film, it may be provided on the first substrate **1708** side.

It is to be noted that a panel of a display device with a top emission structure is shown in FIG. **17** and a bottom emission structure is shown in FIG. **18**, however, a dual emission structure may also be employed, needless to say.

A light emitting element with a dual emission structure is described with reference to FIG. **21**.

The light emitting element with a dual emission structure is formed of a column signal line (anode) **2102** formed of a light transmissive conductive oxide film, a layer **2104** containing an organic compound, and a row signal line **2105** formed of a light transmissive conductive oxide film. A partition **2103** is formed of a material which shields light. The light emitting element is formed over a first substrate **2101** with a base film **2107** interposed therebetween. It is to be noted that the base film **2107** may be formed of a single layer of a layer having a heat dissipation effect or stacked layers of this film and silicon nitride oxide and silicon oxynitride, as described in the panel configuration of FIG. **17**. The layer having a heat dissipation effect may be formed of aluminum nitride (AlN) having a light transmissivity and diamond. It is to be noted that aluminum nitride (AlN) may contain 0.1 to 30 atomic % of oxygen (O). That is, aluminum nitride oxide (AlN_xO_y) may be formed as well.

The light emitted from the light emitting element is extracted in a direction shown by arrows in FIG. **21**, that is a direction to pass through the first substrate **2101** and a direction to pass through a second substrate **2106**. Therefore, the first substrate **2101** and the second substrate **2106** are both formed of a substrate having a light transmissivity.

In the case of providing an optical film, the optical film may be provided for both the first substrate **2101** and the second substrate **2106**.

An example where the partition is not in a reverse tapered shape, but in a forward tapered shape is described with reference to FIG. **22**. It is to be noted that a light emitting element which emits white light and a color filter are used for performing a full color display.

A base film **2210** is formed over a first substrate **2201**, over which a first electrode **2202** in a stripe shape is formed. In this configuration, a partition **2203** having an aperture is provided on the first electrode **2202**, over which a partition is formed of a spacer **2206** and an overhang portion **2207** of which width is wide on the spacer **2206**. It is to be noted that the base film **2210** can be formed of alumina (Al₂O₃), cubic boron nitride (c-BN), aluminum nitride (AlN), BeO (beryllia), diamond and the like which are high in heat conductivity. The base film **2210** can be formed of a single layer of the aforementioned substance or stacked layers of the aforementioned substance and a silicon nitride oxide film and a silicon oxynitride film. It is to be noted that aluminum nitride (AlN) may contain 0.1 to 30 atomic % of oxygen (O). That is, aluminum nitride oxide (AlN_xO_y) may be formed as well.

The spacer **2206** is formed of an organic resin film such as polyimide while the overhang portion **2207** is formed of a photosensitive resin film such as a resist. An organic resin film such as polyimide is formed and then a pattern of a photosensitive resin film such as a resist is left between electrodes to be separated. Then, an exposed organic resin film is etched. At this time, an etching condition is controlled so as to form an undercut beneath the pattern of the photosensitive resin. Through these steps, an element separation structure including an overhang structure, that is a partition can be formed.

In FIG. **22**, the partition **2203** having an aperture, the spacer **2206**, or the overhang portion **2207** is formed of a material which shields light so as to improve the contrast.

By forming a layer containing an organic compound and a light transmissive conductive film after forming the partition,

a layer **2204** containing an organic compound and a second electrode **2205** can be formed.

In FIG. **22**, the layer **2204** containing an organic compound is formed of stacked layers of a green light emission layer in which coumarin 6 is doped to Alq₃ and a yellow light emission layer in which rubrene is doped to TPD, which forms a white light emitting element utilizing the light emission of two layers. In this configuration, a step of depositing materials for each light emission color can be omitted, therefore, the time required for manufacturing a passive matrix light emitting device can be reduced.

A color filter formed only of colored layers **2208R**, **2208G**, and **2208B** is provided over a second substrate **2209** at a counter position of a pixel of the white light emitting element. Moreover, a black matrix (also referred to as a BM) which separates these color filters is provided.

As only a light emitting element which emits white light is provided in the pixel portion in the configuration of FIG. **22**, a compensation function can be performed more accurately by forming a monitor element using a similar material to that of the light emitting element to obtain similar element characteristics.

[Embodiment Mode 8]

In this embodiment mode, a pixel configuration which can be applied to a pixel configuration of the active type display device of the invention is described.

The pixel configuration is not limited to those described in FIGS. **2**, **3**, **5**, and **8**, but another pixel configuration employing a voltage drive type pixel transistor can be used as well. That is, the invention can be applied to a display device having a pixel configuration employing a transistor which operates in a linear region as a driving transistor of a light emitting element.

First, an operation of a pixel configuration of the display device shown in FIG. **2**, **3**, **5**, or **8** is described with reference to FIG. **25A**. The pixel configuration includes a switching transistor **2501**, a capacitor **2502**, a driving transistor **2503**, a light emitting element **2504**, a gate signal line **2505**, a source signal line **2506**, and a power source line **2507**. A gate terminal of the switching transistor **2501** is connected to the gate signal line **2505**. A source terminal of the switching transistor **2501** is connected to the source signal line **2506**, a drain terminal thereof is connected to a gate terminal of the driving transistor **2503**. One terminal of the capacitor **2502** is connected to the gate terminal of the driving transistor **2503** while the other terminal thereof is connected to the power source line **2507**. A source terminal of the driving transistor **2503** is connected to the power source line **2507** and a drain terminal thereof is connected to an anode of the light emitting element **2504**. When the switching transistor **2501** is turned on by a signal inputted from the gate signal line **2505**, a digital video signal is inputted from the source signal line **2505** to the gate terminal of the driving transistor **2503**. A voltage of the inputted digital video signal is held in the capacitor **2502**. By the inputted digital video signal, the driving transistor **2503** is turned on/off, which controls to set a potential by the power source line **2507** at an anode of the light emitting element **2504**. By setting a potential of the power source line **2507** according to the invention, a current value supplied to the light emitting element **2504**, which varies due to a temperature change and a change with time can be corrected. Further, a steady voltage supply can be provided.

Further, the invention can be applied to a display device having a pixel configuration as shown in FIG. **25B**. The configuration shown in FIG. **25B** corresponds to the configuration of FIG. **25A** in which an erasing transistor **2508** and an erasing signal line **2509** are additionally provided. Accord-

ingly, common reference numerals are used for the common portions. In this configuration, when an erasing signal is inputted to the erasing signal line **2509** and the erasing transistor **2508** is turned on, a charge held in the capacitor **2502** is discharged and the driving transistor **2503** is turned off, which makes the light emitting element **2504** emit no light. In this configuration also, according to the invention, a current value supplied to the light emitting element **2504**, which varies due to a temperature change and a change with time can be corrected by setting a potential of the power source line **2507**. Further, a steady voltage supply can be provided.

The invention can be applied to a pixel configuration in which polarity of a transistor in the pixel is appropriately changed, a connection is changed, or a transistor is additionally provided, as well as to the aforementioned configuration. [Embodiment Mode 9]

The invention can be applied to various electronic devices. In specific, the invention can be applied to a display portion of an electronic device. Such electronic devices include a video camera, a digital camera, a goggle type display (head mounted display), a navigation system, an audio reproducing device (car audio, audio component set and the like), a computer, a game machine, a portable information terminal (mobile computer, portable phone, portable game machine, electronic book, or the like), an image reproducing device provided with a recording medium (specifically, a device which reproduces a recording medium such as a DVD (Digital Versatile Disc) and has a display which can display the reproduced image), and the like.

FIG. **26A** illustrates a display including a housing **26001**, a support base **26002**, a display portion **26003**, speaker portions **26004**, a video input terminal **26005** and the like. The display having the display portion **26003** to which the invention is applied can suppress luminance variations caused by a temperature change and reduce the apparent luminance deterioration. It is to be noted that a display includes all display devices for displaying information, such as ones for a personal computer, TV broadcast reception, and advertisement.

FIG. **26B** illustrates a camera including a main body **26101**, a display portion **26102**, an image receiving portion **26103**, operating keys **26104**, an external connecting port **26105**, a shutter **26106** and the like. The camera having the display portion **26102** to which the invention is applied can suppress luminance variations caused by a temperature change and reduce the apparent luminance deterioration.

FIG. **21C** illustrates a computer including a main body **26201**, a housing **26202**, a display portion **26203**, a keyboard **26204**, an external connecting port **26205**, a pointing mouse **26206** and the like. The computer having the display portion **26203** to which the invention is applied can suppress luminance variations caused by a temperature change and reduce the apparent luminance deterioration.

FIG. **26D** illustrates a mobile computer including a main body **26301**, a display portion **26302**, a switch **26303**, operating keys **26304**, an infrared port **26305** and the like. The mobile computer having the display portion **26302** to which the invention is applied can suppress luminance variations caused by a temperature change and reduce the apparent luminance deterioration.

FIG. **26E** illustrates a portable image reproducing device provided with a recording medium (specifically a DVD reproducing device), including a main body **26401**, a housing **26402**, a display portion A **26403**, a display portion B **26404**, a recording medium (such as a DVD) reading portion **26405**, an operating key **26406**, a speaker portion **26407**, and the like. The display portion A **26403** mainly displays image data while the display portion B **26404** mainly displays text data.

37

The image reproducing device having the display portion A **26403** and the display portion B **26404** to which the invention is applied can suppress luminance variations caused by a temperature change and reduce the apparent luminance deterioration.

FIG. **26F** illustrates a goggle type display including a main body **26501**, a display portion **26502**, and an arm portion **26503**. The goggle type display having the display portion **26502** to which the invention is applied can suppress luminance variations caused by a temperature change and reduce the apparent luminance deterioration.

FIG. **26G** illustrates a video camera including a main body **26601**, a display portion **26602**, a housing **26603**, an external connecting port **26604**, a remote control receiving portion **26605**, an image receiving portion **26606**, a battery **26607**, an audio input portion **26608**, operating keys **26609** and the like. The video camera having the display portion **26602** to which the invention is applied can suppress luminance variations caused by a temperature change and reduce the apparent luminance deterioration.

FIG. **26H** illustrates a portable phone including a main body **26701**, a housing **26702**, a display portion **26703**, an audio input portion **26704**, an audio output portion **26705**, an operating key **26706**, an external connecting port **26707**, an antenna **26708** and the like. The portable phone having the display portion **26703** to which the invention is applied can suppress luminance variations caused by a temperature change and reduce the apparent luminance deterioration.

In this manner, the invention can be applied to various electronic devices.

This application is based on Japanese Patent Application serial no. 2004-242820 filed in Japan Patent Office on 23, Aug. 2004, the entire contents of which are hereby incorporated by reference.

What is claimed is:

1. A display device comprising:

a pixel portion comprising:

a first pixel electrically connected to a first source signal line and a first gate signal line;

a second pixel electrically connected to a second source signal line and the first gate signal line;

a third pixel electrically connected to the first source signal line and a second gate signal line; and

a fourth pixel electrically connected to the second source signal line and the second gate signal line;

a first amplifier;

a second amplifier;

a first element; and

a second element,

wherein each of the first pixel, the second pixel, the third pixel and the fourth pixel comprises a first transistor, a second transistor and a light emitting element;

wherein a gate of the first transistor of the first pixel is electrically connected to the first gate signal line,

wherein a gate of the first transistor of the second pixel is electrically connected to the first gate signal line,

wherein a gate of the first transistor of the third pixel is electrically connected to the second gate signal line,

wherein a gate of the first transistor of the fourth pixel is electrically connected to the second gate signal line,

wherein one of a source and a drain of the first transistor of the first pixel is electrically connected to the first source signal line,

wherein one of a source and a drain of the first transistor of the second pixel is electrically connected to the second source signal line,

38

wherein one of a source and a drain of the first transistor of the third pixel is electrically connected to the first source signal line,

wherein one of a source and a drain of the first transistor of the fourth pixel is electrically connected to the second source signal line,

wherein the other of the source and the drain of the first transistor of the first pixel is electrically connected to a gate of the second transistor of the first pixel,

wherein the other of the source and the drain of the first transistor of the second pixel is electrically connected to a gate of the second transistor of the second pixel,

wherein the other of the source and the drain of the first transistor of the third pixel is electrically connected to a gate of the second transistor of the third pixel,

wherein the other of the source and the drain of the first transistor of the fourth pixel is electrically connected to a gate of the second transistor of the fourth pixel,

wherein one of a source and a drain of the second transistor of the first pixel is electrically connected to the light emitting element of the first pixel,

wherein one of a source and a drain of the second transistor of the second pixel is electrically connected to the light emitting element of the second pixel,

wherein one of a source and a drain of the second transistor of the third pixel is electrically connected to the light emitting element of the third pixel,

wherein one of a source and a drain of the second transistor of the fourth pixel is electrically connected to the light emitting element of the fourth pixel,

wherein the other of the source and the drain of the second transistor of the first pixel is electrically connected to a first power source line,

wherein the other of the source and the drain of the second transistor of the second pixel is electrically connected to the first power source line,

wherein the other of the source and the drain of the second transistor of the third pixel is electrically connected to a second power source line,

wherein the other of the source and the drain of the second transistor of the fourth pixel is electrically connected to the second power source line,

wherein the first amplifier is electrically connected to the first power source line,

wherein the second amplifier is electrically connected to the second power source line,

wherein each of the first element and the second element comprises the same materials as the light emitting element,

wherein the light emitting element of the first pixel, the light emitting element of the second pixel and the first element are arranged in a direction parallel to the first gate signal line, and

wherein the light emitting element of the third pixel, the light emitting element of the fourth pixel and the second element are arranged in a direction parallel to the second gate signal line.

2. The display device according to claim 1, wherein each of the first element and the second element is a monitor element.

3. The display device according to claim 1, wherein each of the first amplifier and the second amplifier is a voltage follower circuit.

4. The display device according to claim 1, wherein the light emitting element is an EL element.

5. The display device according to claim 1, wherein the second transistor is formed over a substrate,

39

wherein a first electrode of the light emitting element is formed over the second transistor,
 wherein a layer comprising an organic compound is formed over the first electrode,
 wherein a second electrode of the light emitting element is formed over the layer comprising the organic compound, and
 wherein a color filter is provided over the second electrode.

6. An electronic device comprising the display device according to claim 1 in a display portion.

7. A display device comprising:
 a pixel portion comprising:
 a first pixel electrically connected to a first line and a second line; and
 a second pixel electrically connected to a third line and the second line;
 a third pixel electrically connected to the first line and a fourth line; and
 a fourth pixel electrically connected to the third line and the fourth line;
 a first amplifier;
 a second amplifier;
 a first element; and
 a second element,
 wherein each of the first pixel, the second pixel, the third pixel and the fourth pixel comprises a first transistor, a second transistor and a light emitting element;
 wherein a gate of the first transistor of the first pixel is electrically connected to the second line,
 wherein a gate of the first transistor of the second pixel is electrically connected to the second line,
 wherein a gate of the first transistor of the third pixel is electrically connected to the fourth line,
 wherein a gate of the first transistor of the fourth pixel is electrically connected to the fourth line,
 wherein one of a source and a drain of the first transistor of the first pixel is electrically connected to the first line,
 wherein one of a source and a drain of the first transistor of the second pixel is electrically connected to the third line,
 wherein one of a source and a drain of the first transistor of the third pixel is electrically connected to the first line,
 wherein one of a source and a drain of the first transistor of the fourth pixel is electrically connected to the third line,
 wherein the other of the source and the drain of the first transistor of the first pixel is electrically connected to a gate of the second transistor of the first pixel,
 wherein the other of the source and the drain of the first transistor of the second pixel is electrically connected to a gate of the second transistor of the second pixel,
 wherein the other of the source and the drain of the first transistor of the third pixel is electrically connected to a gate of the second transistor of the third pixel,
 wherein the other of the source and the drain of the first transistor of the fourth pixel is electrically connected to a gate of the second transistor of the fourth pixel,
 wherein one of a source and a drain of the second transistor of the first pixel is electrically connected to the light emitting element of the first pixel,

40

wherein one of a source and a drain of the second transistor of the second pixel is electrically connected to the light emitting element of the second pixel,
 wherein one of a source and a drain of the second transistor of the third pixel is electrically connected to the light emitting element of the third pixel,
 wherein one of a source and a drain of the second transistor of the fourth pixel is electrically connected to the light emitting element of the fourth pixel,
 wherein the other of the source and the drain of the second transistor of the first pixel is electrically connected to a fifth line,
 wherein the other of the source and the drain of the second transistor of the second pixel is electrically connected to the fifth line,
 wherein the other of the source and the drain of the second transistor of the third pixel is electrically connected to a sixth line,
 wherein the other of the source and the drain of the second transistor of the fourth pixel is electrically connected to the sixth line,
 wherein the first amplifier is electrically connected to the fifth line,
 wherein the second amplifier is electrically connected to the sixth line,
 wherein each of the first element and the second element comprises the same materials as the light emitting element,
 wherein the light emitting element of the first pixel, the light emitting element of the second pixel and the first element are arranged in a direction parallel to the second line, and
 wherein the light emitting element of the third pixel, the light emitting element of the fourth pixel and the second element are arranged in a direction parallel to the fourth line.

8. The display device according to claim 7, wherein each of the first element and the second element is a monitor element.

9. The display device according to claim 7, wherein each of the first amplifier and the second amplifier is a voltage follower circuit.

10. The display device according to claim 7, wherein the light emitting element is an EL element.

11. The display device according to claim 7,
 wherein the second transistor is formed over a substrate,
 wherein a first electrode of the light emitting element is formed over the second transistor,
 wherein a layer comprising an organic compound is formed over the first electrode,
 wherein a second electrode of the light emitting element is formed over the layer comprising the organic compound, and
 wherein a color filter is provided over the second electrode.

12. An electronic device comprising the display device according to claim 7 in a display portion.

* * * * *

UNITED STATES PATENT AND TRADEMARK OFFICE
CERTIFICATE OF CORRECTION

PATENT NO. : 8,576,147 B2
APPLICATION NO. : 13/484489
DATED : November 5, 2013
INVENTOR(S) : Jun Koyama et al.

Page 1 of 1

It is certified that error appears in the above-identified patent and that said Letters Patent is hereby corrected as shown below:

In the Specifications

Column 3, line 58, after “color” delete “is”;

Column 7, line 4, after “resistance” delete “a”;

Column 11, line 46, after “to” replace “202a” with --202a_m--;

Column 12, line 66, after “V_m” delete “,”;

Column 13, line 62, after “connected” delete “to”;

Column 15, line 6, after “411a₄,” insert --...,--;

Column 15, line 63, after “402a_m” delete “,”;

Column 16, line 55, after “502a_m” delete “,”;

Column 16, line 60, after “502a_m” delete “,”;

Column 17, line 53, after “601b_m” delete “,”;

Column 17, line 59, after “603b_m” delete “,”;

Column 22, line 47, replace “_nC” with --C_n--;

Column 23, line 24, before “each” delete “to”;

Column 23, line 50, after “C_n” insert --.--;

Column 27, line 44, replace “MN” with --AIN-- and replace “MN” with --AIN--;

Column 31, line 44, replace “MN” with --AIN-- and replace “MN” with --AIN--;

Column 31, line 46, and replace “MN” with --AIN--.

Signed and Sealed this
Fifteenth Day of April, 2014



Michelle K. Lee
Deputy Director of the United States Patent and Trademark Office