

US008574282B2

(12) **United States Patent**
Andreas et al.

(10) **Patent No.:** **US 8,574,282 B2**
(45) **Date of Patent:** **Nov. 5, 2013**

(54) **APPARATUS AND METHODS FOR DELIVERY OF BRAIDED PROSTHESES**

(75) Inventors: **Bernard Andreas**, Redwood City, CA (US); **Ronald French**, Santa Clara, CA (US); **Mark E. Deem**, Mountain View, CA (US); **Hanson S. Gifford, III**, Woodside, CA (US); **Allan Will**, Atherton, CA (US)

(73) Assignee: **J.W. Medical Systems Ltd.**, Weihai Shangdong (CN)

(*) Notice: Subject to any disclaimer, the term of this patent is extended or adjusted under 35 U.S.C. 154(b) by 115 days.

(21) Appl. No.: **13/078,749**

(22) Filed: **Apr. 1, 2011**

(65) **Prior Publication Data**

US 2011/0178589 A1 Jul. 21, 2011

Related U.S. Application Data

(63) Continuation of application No. 12/040,598, filed on Feb. 29, 2008, now Pat. No. 7,938,852, which is a continuation of application No. 10/966,806, filed on Oct. 14, 2004, now Pat. No. 7,357,812, which is a continuation of application No. 10/306,620, filed on Nov. 27, 2002, now Pat. No. 7,147,656.

(60) Provisional application No. 60/336,607, filed on Dec. 3, 2001.

(51) **Int. Cl.**
A61F 2/06 (2013.01)

(52) **U.S. Cl.**
USPC **623/1.11**

(58) **Field of Classification Search**
USPC 623/1.11-1.16; 606/108
See application file for complete search history.

(56) **References Cited**

U.S. PATENT DOCUMENTS

4,069,825 A	1/1978	Akiyama
4,468,224 A	8/1984	Enzmann et al.
4,512,338 A	4/1985	Balko
4,564,014 A	1/1986	Fogarty et al.
4,580,568 A	4/1986	Gianturco
4,681,110 A	7/1987	Wiktor

(Continued)

FOREIGN PATENT DOCUMENTS

DE	1 953 1659	3/1997
DE	1 963 0469	1/1998

(Continued)

OTHER PUBLICATIONS

Chu et al., "Preparation of Thermo-Responsive Core-Shell Microcapsules with a Porous Membrane and Poly(N-isopropylacrylamide) Gates," J Membrane Sci, Oct. 15, 2001; 192(1-2):27-39.

(Continued)

Primary Examiner — Suzette J Gherbi

(74) *Attorney, Agent, or Firm* — Kilpatrick Townsend & Stockton LLP

(57) **ABSTRACT**

Blood vessels and other body lumens are expanded using an evertible braided prosthesis. The braided prosthesis is delivered to the blood vessel in a radially collapsed configuration. A leading edge of the braided prosthesis is then everted so that it expands as it is advanced through the blood vessel. Optionally, the prosthesis can be provided with a biologically active substance in order to inhibit hyperplasia or have other desired biological effects.

8 Claims, 2 Drawing Sheets

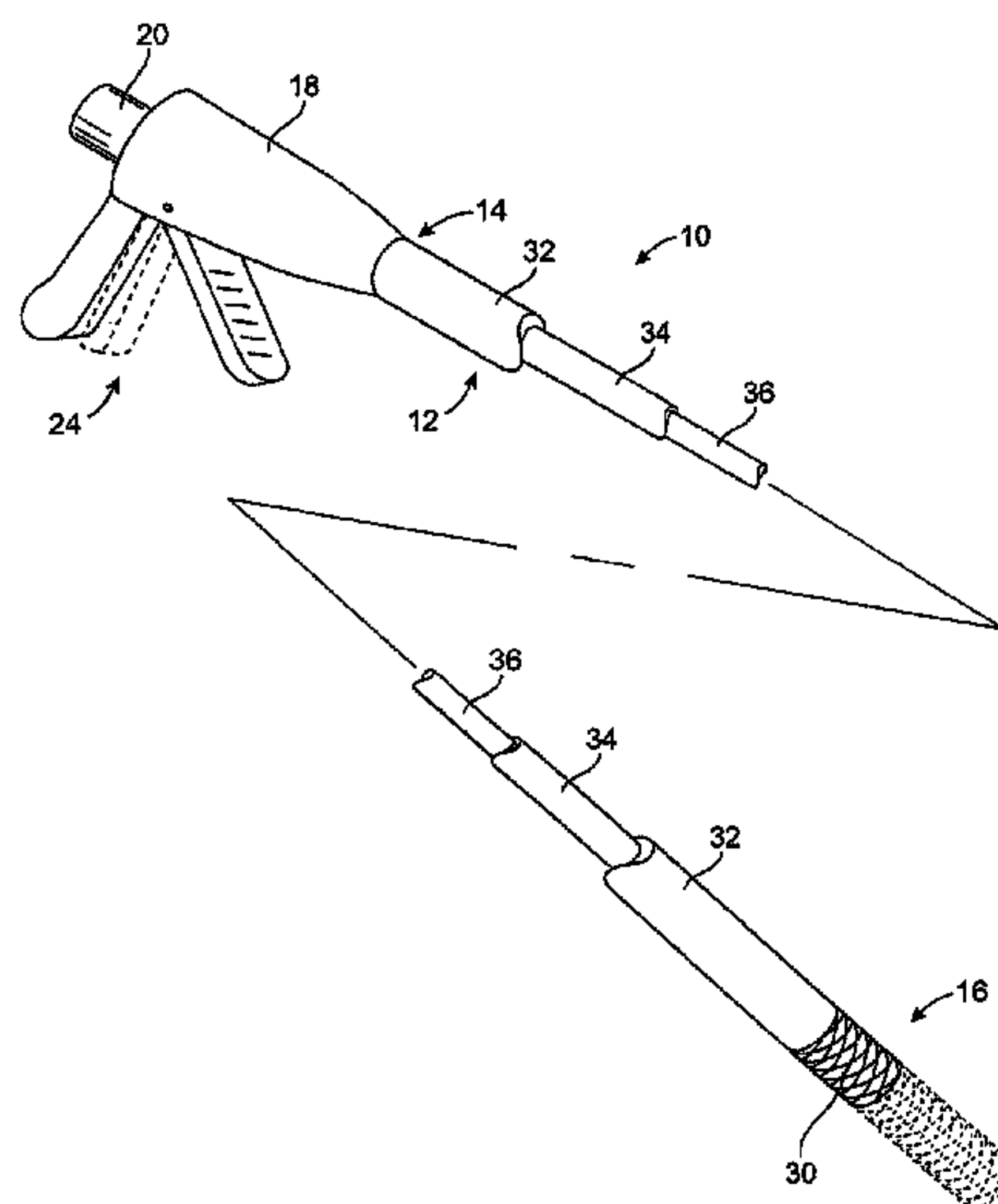

(56)

References Cited

U.S. PATENT DOCUMENTS

4,690,684 A	9/1987	McGreevy et al.	5,662,675 A	9/1997	Polanskyj Stockert et al.
4,733,665 A	3/1988	Palmaz	5,662,703 A *	9/1997	Yurek et al. 623/1.12
4,739,762 A	4/1988	Palmaz	5,670,161 A	9/1997	Healy et al.
4,748,982 A	6/1988	Horzewski et al.	5,676,654 A	10/1997	Ellis et al.
4,762,129 A	8/1988	Bonzel	5,683,451 A	11/1997	Lenker et al.
4,770,176 A	9/1988	McGreevy et al.	5,690,644 A	11/1997	Yurek et al.
4,775,337 A	10/1988	Van Wagener et al.	5,693,085 A	12/1997	Buirge et al.
4,776,337 A	10/1988	Palmaz	5,697,948 A	12/1997	Marin et al.
4,886,062 A	12/1989	Wiktor	5,697,971 A	12/1997	Fischell et al.
4,891,225 A	1/1990	Langer et al.	5,702,418 A	12/1997	Ravenscroft
4,950,227 A	8/1990	Savin et al.	5,702,419 A *	12/1997	Berry et al. 623/1.13
4,988,356 A	1/1991	Crittenden et al.	5,709,701 A	1/1998	Parodi
4,994,066 A	2/1991	Voss	5,716,393 A	2/1998	Lindenberg et al.
4,994,069 A	2/1991	Ritchart et al.	5,722,669 A	3/1998	Shimizu et al.
4,994,298 A	2/1991	Yasuda	5,723,003 A	3/1998	Winston et al.
5,013,318 A	5/1991	Spranza, III	5,735,869 A	4/1998	Fernandez-Aceytuno
5,035,706 A	7/1991	Giantureo et al.	5,741,323 A	4/1998	Pathak et al.
5,040,548 A	8/1991	Yock	5,749,848 A	5/1998	Jang et al.
5,061,273 A	10/1991	Yock	5,749,890 A	5/1998	Shaknovich
5,064,435 A	11/1991	Porter	5,749,921 A	5/1998	Lenker et al.
5,092,877 A	3/1992	Pinchuk	5,755,772 A	5/1998	Evans et al.
5,102,417 A	4/1992	Palmaz	5,755,776 A	5/1998	Al-Saadon
5,104,404 A	4/1992	Wolff	5,755,781 A	5/1998	Jayaraman
5,122,154 A	6/1992	Rhodes	5,769,882 A	6/1998	Fogarty et al.
5,135,535 A	8/1992	Kramer	5,772,669 A	6/1998	Vrba
5,158,548 A	10/1992	Lau et al.	5,776,141 A	7/1998	Klein et al.
5,192,297 A	3/1993	Hull	5,792,144 A	8/1998	Fischell et al.
5,195,984 A	3/1993	Schatz	5,797,951 A	8/1998	Mueller et al.
5,201,757 A	4/1993	Heyn et al.	5,800,519 A	9/1998	Sandock
5,217,495 A	6/1993	Kaplan et al.	5,807,398 A	9/1998	Shaknovich
5,219,355 A	6/1993	Parodi et al.	5,824,040 A	10/1998	Cox et al.
5,226,913 A	7/1993	Pinchuk	5,824,041 A	10/1998	Lenker et al.
5,246,421 A	9/1993	Saab	5,833,694 A	11/1998	Poncet
5,273,536 A	12/1993	Savas	5,836,964 A	11/1998	Richter et al.
5,282,824 A	2/1994	Gianturco	5,843,092 A	12/1998	Heller et al.
5,300,085 A	4/1994	Yock	5,855,563 A	1/1999	Kaplan et al.
5,312,415 A	5/1994	Palermo	5,858,556 A	1/1999	Eckert et al.
5,328,469 A *	7/1994	Coletti 604/103.09	5,870,381 A	2/1999	Kawasaki et al.
5,334,187 A	8/1994	Fischell et al.	5,879,370 A	3/1999	Fischell et al.
5,391,172 A	2/1995	Williams et al.	5,891,190 A	4/1999	Boneau
5,421,955 A	6/1995	Lau et al.	5,895,398 A	4/1999	Wensel et al.
5,443,498 A	8/1995	Fontaine	5,899,935 A	5/1999	Ding
5,445,646 A	8/1995	Euteneuer et al.	5,902,332 A	5/1999	Schatz
5,456,713 A	10/1995	Chuter	5,919,175 A	7/1999	Sirhan
5,458,615 A	10/1995	Klemm et al.	5,921,971 A	7/1999	Agro et al.
5,470,315 A	11/1995	Adams	5,922,020 A	7/1999	Klein et al.
5,478,349 A	12/1995	Nicholas	5,941,869 A	8/1999	Patterson et al.
5,484,444 A	1/1996	Braunschweiler et al.	5,951,585 A	9/1999	Cathcart et al.
5,490,837 A	2/1996	Blaeser et al.	5,961,536 A	10/1999	Mickley et al.
5,496,346 A	3/1996	Horzewski et al.	5,968,069 A	10/1999	Dusbabek et al.
5,501,227 A	3/1996	Yock	5,972,027 A	10/1999	Johnson
5,507,768 A	4/1996	Lau et al.	5,976,107 A	11/1999	Mertens et al.
5,507,771 A	4/1996	Gianturco	5,976,155 A	11/1999	Foreman et al.
5,514,093 A	5/1996	Ellis et al.	5,980,484 A	11/1999	Ressemann et al.
5,514,154 A	5/1996	Lau et al.	5,980,486 A	11/1999	Enger
5,522,882 A	6/1996	Gaterud et al.	5,980,514 A	11/1999	Kupiecki et al.
5,527,354 A	6/1996	Fontaine et al.	5,980,552 A	11/1999	Pinchasik et al.
5,531,735 A	7/1996	Thompson	5,984,957 A	11/1999	Laptewicz, Jr. et al.
5,533,968 A	7/1996	Muni et al.	5,989,280 A	11/1999	Euteneuer et al.
5,534,007 A	7/1996	St. Germain et al.	5,993,484 A	11/1999	Shmulewitz
5,545,209 A	8/1996	Roberts et al.	5,997,563 A	12/1999	Kretzers et al.
5,549,551 A	8/1996	Peacock, III et al.	6,004,328 A	12/1999	Solar
5,549,563 A	8/1996	Kronner	6,007,517 A	12/1999	Anderson
5,549,635 A	8/1996	Solar	6,010,530 A	1/2000	Goicoechea
5,554,181 A	9/1996	Das	6,022,359 A	2/2000	Frantzen
5,562,725 A	10/1996	Schmitt et al.	6,022,374 A	2/2000	Imran
5,571,086 A	11/1996	Kaplan et al.	6,027,519 A	2/2000	Stanford
5,591,195 A	1/1997	Taheri et al.	6,033,434 A	3/2000	Borghi
5,593,412 A	1/1997	Martinez et al.	6,036,725 A	3/2000	Avellanet
5,607,444 A	3/1997	Lam	6,039,721 A	3/2000	Johnson et al.
5,607,463 A	3/1997	Schwartz et al.	6,042,589 A	3/2000	Marianne
5,628,755 A	5/1997	Heller et al.	6,056,722 A	5/2000	Jayaraman
5,628,775 A	5/1997	Jackson et al.	6,063,111 A	5/2000	Hieshima et al.
5,634,928 A	6/1997	Fischell et al.	6,066,155 A	5/2000	Amann et al.
5,639,274 A	6/1997	Fischell et al.	6,068,655 A	5/2000	Seguin et al.
			6,070,589 A	6/2000	Keith et al.
			6,090,063 A	7/2000	Makower et al.
			6,090,136 A	7/2000	McDonald et al.
			6,102,942 A	8/2000	Ahari

(56)

References Cited

U.S. PATENT DOCUMENTS

6,106,530 A	8/2000	Harada	6,555,157 B1	4/2003	Hossainy
RE36,857 E	9/2000	Euteneuer et al.	6,558,415 B2	5/2003	Thompson
6,120,522 A	9/2000	Vrba et al.	6,562,067 B2	5/2003	Mathis
6,123,712 A	9/2000	Di Caprio et al.	6,569,180 B1	5/2003	Sirhan et al.
6,123,723 A	9/2000	Konya et al.	6,575,993 B1	6/2003	Yock
6,126,685 A	10/2000	Lenker et al.	6,579,305 B1	6/2003	Lashinski
6,129,756 A	10/2000	Kugler	6,579,309 B1	6/2003	Loos et al.
6,132,460 A	10/2000	Thompson	6,582,394 B1	6/2003	Reiss et al.
6,139,572 A	10/2000	Campbell et al.	6,582,460 B1	6/2003	Cryer
6,143,016 A	11/2000	Bleam et al.	6,585,756 B1	7/2003	Strecker
6,165,167 A	12/2000	Delaloye	6,589,273 B1	7/2003	McDermott
6,165,210 A	12/2000	Lau et al.	6,592,549 B2	7/2003	Gerdts et al.
6,171,334 B1	1/2001	Cox	6,599,296 B1	7/2003	Gillick et al.
6,179,878 B1	1/2001	Duering	6,599,314 B2	7/2003	Mathis
6,183,509 B1	2/2001	Dibie	6,602,226 B1	8/2003	Smith et al.
6,187,034 B1	2/2001	Frantzen	6,602,282 B1	8/2003	Yan
6,190,402 B1	2/2001	Horton et al.	6,605,062 B1	8/2003	Hurley et al.
6,196,995 B1	3/2001	Fagan	6,605,109 B2	8/2003	Fiedler
6,200,337 B1	3/2001	Moriuchi et al.	6,607,553 B1	8/2003	Healy et al.
6,217,585 B1	4/2001	Houser et al.	6,613,074 B1	9/2003	Mitelberg et al.
6,238,991 B1	5/2001	Suzuki	6,629,992 B2	10/2003	Bigus et al.
6,241,691 B1	6/2001	Ferrera et al.	6,645,517 B2	11/2003	West
6,241,758 B1	6/2001	Cox	6,645,547 B1	11/2003	Shekalim et al.
6,248,122 B1	6/2001	Klumb et al.	6,656,212 B2	12/2003	Ravenscroft et al.
6,251,132 B1	6/2001	Ravenscroft et al.	6,660,031 B2	12/2003	Tran et al.
6,251,134 B1	6/2001	Alt et al.	6,660,381 B2	12/2003	Halas et al.
6,254,612 B1	7/2001	Hieshima	6,663,660 B2	12/2003	Dusbabek et al.
6,254,628 B1	7/2001	Wallace et al.	6,666,883 B1	12/2003	Seguin et al.
6,258,117 B1	7/2001	Camrud et al.	6,676,693 B1	1/2004	Belding et al.
6,264,688 B1	7/2001	Herklotz et al.	6,676,695 B2	1/2004	Solem
6,267,783 B1	7/2001	Letendre et al.	6,679,909 B2	1/2004	McIntosh et al.
6,270,524 B1	8/2001	Kim	6,685,730 B2	2/2004	West et al.
6,273,895 B1	8/2001	Pinchuk et al.	6,692,465 B2	2/2004	Kramer
6,273,911 B1	8/2001	Cox et al.	6,699,280 B2	3/2004	Camrud et al.
6,273,913 B1	8/2001	Wright et al.	6,699,281 B2	3/2004	Vallana et al.
6,287,291 B1	9/2001	Bigus et al.	6,699,724 B1	3/2004	West et al.
6,312,458 B1	11/2001	Golds	6,702,843 B1	3/2004	Brown
6,315,794 B1	11/2001	Richter	6,709,379 B1	3/2004	Brandau et al.
6,319,277 B1	11/2001	Rudnick et al.	6,709,440 B2	3/2004	Callol et al.
6,322,586 B1	11/2001	Monroe et al.	6,712,827 B2	3/2004	Ellis et al.
6,325,823 B1	12/2001	Horzewski et al.	6,712,845 B2	3/2004	Hossainy
6,334,871 B1	1/2002	Dor et al.	6,723,071 B2	4/2004	Gerdts et al.
6,340,366 B2	1/2002	Wijay	6,736,842 B2	5/2004	Healy et al.
6,344,272 B1	2/2002	Oldenburg et al.	6,743,219 B1	6/2004	Dwyer et al.
6,348,065 B1	2/2002	Brown et al.	6,743,251 B1	6/2004	Eder
6,350,252 B2	2/2002	Ray et al.	6,761,734 B2	7/2004	Suhr
6,350,277 B1	2/2002	Kocur	6,776,771 B2	8/2004	van Moorlegem et al.
6,357,104 B1	3/2002	Myers	6,778,316 B2	8/2004	Halas et al.
6,361,558 B1	3/2002	Hieshima et al.	6,790,227 B2	9/2004	Burgermeister
6,375,676 B1	4/2002	Cox	6,800,065 B2	10/2004	Duane et al.
6,379,365 B1	4/2002	Diaz	6,825,203 B2	11/2004	Pasternak et al.
6,383,171 B1	5/2002	Gifford et al.	6,837,901 B2	1/2005	Rabkin et al.
6,394,995 B1	5/2002	Solar et al.	6,849,084 B2	2/2005	Rabkin et al.
6,409,753 B1	6/2002	Brown et al.	6,852,252 B2	2/2005	Halas et al.
6,415,696 B1	7/2002	Erickeson et al.	6,855,125 B2	2/2005	Shanley
6,416,543 B1	7/2002	Hilaire et al.	6,858,034 B1	2/2005	Hijlkema et al.
6,419,693 B1	7/2002	Fariabi	6,878,161 B2	4/2005	Lenker
6,425,898 B1	7/2002	Wilson et al.	6,884,257 B1	4/2005	Cox
6,428,811 B1	8/2002	West et al.	6,893,417 B2	5/2005	Gribbons et al.
6,451,025 B1	9/2002	Jervis	6,896,695 B2	5/2005	Mueller et al.
6,451,050 B1	9/2002	Rudakov et al.	6,899,728 B1 *	5/2005	Phillips et al. 623/1.13
6,464,720 B2	10/2002	Boatman et al.	6,913,619 B2	7/2005	Brown et al.
6,468,298 B1	10/2002	Pelton	6,918,928 B2	7/2005	Wolinsky et al.
6,468,299 B2	10/2002	Stack et al.	6,939,376 B2	9/2005	Shulz et al.
6,485,510 B1	11/2002	Camrud et al.	6,945,989 B1	9/2005	Betelia et al.
6,488,694 B1	12/2002	Lau et al.	6,945,995 B2	9/2005	Nicholas
6,488,702 B1	12/2002	Besselink	6,951,053 B2	10/2005	Padilla et al.
6,511,468 B1	1/2003	Cragg et al.	6,962,603 B1	11/2005	Brown et al.
6,520,986 B2	2/2003	Martin et al.	6,964,676 B1	11/2005	Gerberding et al.
6,520,987 B1	2/2003	Plante	6,991,646 B2	1/2006	Clerc et al.
6,527,789 B1	3/2003	Lau et al.	6,994,721 B2	2/2006	Israel
6,527,799 B2	3/2003	Shanley	7,005,454 B2	2/2006	Brocchini et al.
6,530,944 B2	3/2003	West et al.	7,022,132 B2	4/2006	Kocur
6,540,777 B2	4/2003	Stenzel	7,029,493 B2	4/2006	Majercak et al.
6,551,350 B1	4/2003	Thornton et al.	7,037,327 B2	5/2006	Salmon et al.
			7,090,694 B1	8/2006	Morris et al.
			7,101,840 B2	9/2006	Brocchini et al.
			7,131,993 B2	11/2006	Gregorich
			7,137,993 B2	11/2006	Acosta et al.

(56)

References Cited

U.S. PATENT DOCUMENTS

7,141,063 B2	11/2006	White et al.	2003/0163085 A1	8/2003	Tanner et al.
7,147,655 B2	12/2006	Chermoni	2003/0176909 A1	9/2003	Kusleika
7,147,656 B2 *	12/2006	Andreas et al. 623/1.11	2003/0191516 A1	10/2003	Weldon et al.
7,169,172 B2	1/2007	Levine et al.	2003/0195609 A1	10/2003	Berenstein
7,169,174 B2	1/2007	Fischell et al.	2003/0199821 A1	10/2003	Gerdts et al.
7,172,620 B2	2/2007	Gilson	2003/0204238 A1	10/2003	Tedeschi
7,175,654 B2	2/2007	Bonsignore et al.	2003/0208223 A1	11/2003	Kleiner
7,182,779 B2	2/2007	Acosta et al.	2003/0212447 A1	11/2003	Euteneuer
7,192,440 B2	3/2007	Andreas et al.	2003/0225446 A1	12/2003	Hartley
7,208,001 B2	4/2007	Coyle et al.	2004/0015224 A1	1/2004	Armstrong et al.
7,208,002 B2	4/2007	Shelso	2004/0024450 A1	2/2004	Shulze et al.
7,220,275 B2	5/2007	Davidson et al.	2004/0030380 A1	2/2004	Shulze et al.
7,220,755 B2	5/2007	Betts et al.	2004/0044395 A1	3/2004	Nelson
7,223,283 B2	5/2007	Chouinard	2004/0073290 A1	4/2004	Chouinard
7,238,197 B2	7/2007	Sequin et al.	2004/0088044 A1	5/2004	Brown et al.
7,241,308 B2	7/2007	Andreas et al.	2004/0093061 A1	5/2004	Acosta et al.
7,244,336 B2	7/2007	Fischer et al.	2004/0093067 A1	5/2004	Israel
7,270,668 B2	9/2007	Andreas et al.	2004/0106979 A1	6/2004	Goicoechea
7,294,146 B2	11/2007	Chew et al.	2004/0111145 A1	6/2004	Serino et al.
7,300,456 B2	11/2007	Andreas et al.	2004/0117008 A1	6/2004	Wnendt et al.
7,309,350 B2	12/2007	Landreville et al.	2004/0143322 A1	7/2004	Litvack et al.
7,314,480 B2	1/2008	Eidenschink et al.	2004/0176832 A1	9/2004	Hartley et al.
7,320,702 B2	1/2008	Hammersmark et al.	2004/0181239 A1	9/2004	Dorn et al.
7,323,006 B2	1/2008	Andreas et al.	2004/0186551 A1	9/2004	Kao et al.
7,326,236 B2	2/2008	Andreas et al.	2004/0193245 A1	9/2004	Deem et al.
7,351,255 B2	4/2008	Andreas	2004/0215165 A1	10/2004	Coyle et al.
7,534,449 B2	5/2009	Saltzman et al.	2004/0215312 A1	10/2004	Andreas et al.
7,699,886 B2	4/2010	Sugimoto	2004/0215331 A1	10/2004	Chew et al.
7,918,881 B2	4/2011	Andreas et al.	2004/0230285 A1	11/2004	Gifford, III et al.
7,993,388 B2	8/2011	Lee et al.	2004/0243217 A1	12/2004	Andersen et al.
8,257,427 B2	9/2012	Andersen et al.	2004/0249434 A1	12/2004	Andreas et al.
8,317,850 B2 *	11/2012	Kusleika 623/1.12	2004/0249439 A1	12/2004	Richter et al.
2001/0020154 A1	9/2001	Bigus et al.	2005/0004657 A1	1/2005	Burgermeister
2001/0020173 A1	9/2001	Klumb et al.	2005/0010276 A1	1/2005	Acosta et al.
2001/0020181 A1	9/2001	Layne	2005/0038494 A1	2/2005	Eidenschink
2001/0035902 A1	11/2001	Iddan et al.	2005/0038505 A1	2/2005	Shulze et al.
2001/0044595 A1	11/2001	Reydel et al.	2005/0049673 A1	3/2005	Andreas et al.
2001/0044632 A1	11/2001	Daniel et al.	2005/0080474 A1	4/2005	Andreas et al.
2001/0049547 A1	12/2001	Moore	2005/0080475 A1	4/2005	Andreas et al.
2002/0007212 A1	1/2002	Brown et al.	2005/0085897 A1	4/2005	Bonsignore
2002/0037358 A1	3/2002	Barry et al.	2005/0090846 A1	4/2005	Pedersen et al.
2002/0045914 A1 *	4/2002	Roberts et al. 606/192	2005/0123451 A1	6/2005	Nomura
2002/0052642 A1	5/2002	Cox et al.	2005/0125051 A1	6/2005	Eidenschink et al.
2002/0087186 A1	7/2002	Shelso	2005/0131008 A1	6/2005	Betts et al.
2002/0091439 A1	7/2002	Baker et al.	2005/0137622 A1	6/2005	Griffin
2002/0092536 A1	7/2002	LaFontaine et al.	2005/0143827 A1	6/2005	Globerman et al.
2002/0107560 A1	8/2002	Richter	2005/0149168 A1	7/2005	Gregorich
2002/0111671 A1	8/2002	Stenzel	2005/0165378 A1	7/2005	Heinrich et al.
2002/0123786 A1	9/2002	Gittings et al.	2005/0171568 A1	8/2005	Duffy
2002/0128706 A1	9/2002	Ospyka	2005/0182477 A1	8/2005	White
2002/0138132 A1	9/2002	Brown	2005/0209674 A1	9/2005	Kutscher et al.
2002/0151924 A1	10/2002	Shiber	2005/0209676 A1 *	9/2005	Kusleika 623/1.11
2002/0151955 A1	10/2002	Tran et al.	2005/0209680 A1	9/2005	Gale et al.
2002/0156496 A1	10/2002	Chermoni	2005/0222671 A1	10/2005	Schaeffer et al.
2002/0165599 A1	11/2002	Nasralla	2005/0228477 A1	10/2005	Grainger et al.
2002/0168317 A1	11/2002	Daighighian et al.	2005/0245637 A1	11/2005	Hossainy et al.
2002/0177890 A1	11/2002	Lenker	2005/0249777 A1	11/2005	Michal et al.
2002/0183763 A1	12/2002	Callol et al.	2005/0278011 A1	12/2005	Peckham
2002/0188343 A1	12/2002	Mathis	2005/0288764 A1	12/2005	Snow et al.
2002/0188347 A1	12/2002	Mathis	2005/0288766 A1	12/2005	Plain et al.
2002/0193873 A1	12/2002	Brucker et al.	2006/0069424 A1	3/2006	Acosta et al.
2003/0045923 A1	3/2003	Bashiri et al.	2006/0173529 A1	8/2006	Blank
2003/0093143 A1	5/2003	Zhao et al.	2006/0200223 A1	9/2006	Andreas et al.
2003/0097169 A1	5/2003	Brucker et al.	2006/0206190 A1	9/2006	Chermoni
2003/0114912 A1	6/2003	Sequin et al.	2006/0229700 A1	10/2006	Acosta et al.
2003/0114919 A1	6/2003	McQuiston et al.	2006/0229706 A1	10/2006	Shulze et al.
2003/0114922 A1	6/2003	Iwasaka et al.	2006/0271150 A1	11/2006	Andreas et al.
2003/0125791 A1 *	7/2003	Sequin et al. 623/1.11	2006/0271151 A1	11/2006	McGarry et al.
2003/0125800 A1	7/2003	Shulze et al.	2006/0282147 A1	12/2006	Andreas et al.
2003/0125802 A1	7/2003	Callol et al.	2006/0282149 A1	12/2006	Kao
2003/0135259 A1	7/2003	Simso	2006/0282150 A1	12/2006	Olson et al.
2003/0135266 A1	7/2003	Chew et al.	2006/0287726 A1	12/2006	Segal et al.
2003/0139796 A1	7/2003	Sequin et al.	2007/0010869 A1	1/2007	Sano
2003/0139797 A1	7/2003	Johnson et al.	2007/0027521 A1	2/2007	Andreas et al.
2003/0139798 A1	7/2003	Brown et al.	2007/0043419 A1	2/2007	Nikolchev et al.
			2007/0067012 A1	3/2007	George et al.
			2007/0088368 A1	4/2007	Acosta et al.
			2007/0088420 A1	4/2007	Andreas et al.
			2007/0088422 A1	4/2007	Chew et al.

(56)

References Cited

U.S. PATENT DOCUMENTS

2007/0100423 A1 5/2007 Acosta et al.
 2007/0100424 A1 5/2007 Chew et al.
 2007/0106365 A1 5/2007 Andreas et al.
 2007/0118202 A1 5/2007 Chermoni
 2007/0118203 A1 5/2007 Chermoni
 2007/0118204 A1 5/2007 Chermoni
 2007/0129733 A1 6/2007 Will et al.
 2007/0135906 A1 6/2007 Badylak et al.
 2007/0156225 A1 7/2007 George et al.
 2007/0156226 A1 7/2007 Chew et al.
 2007/0179587 A1 8/2007 Acosta et al.
 2007/0219612 A1 9/2007 Andreas et al.
 2007/0219613 A1 9/2007 Kao et al.
 2007/0265637 A1 11/2007 Andreas et al.
 2007/0270936 A1 11/2007 Andreas et al.
 2007/0276461 A1 11/2007 Andreas et al.
 2007/0281117 A1 12/2007 Kaplan et al.
 2007/0292518 A1 12/2007 Ludwig
 2008/0004690 A1 1/2008 Robaina
 2008/0046067 A1 2/2008 Toyokawa
 2008/0071345 A1 3/2008 Hammersmark et al.
 2008/0077229 A1 3/2008 Andreas et al.
 2008/0091257 A1 4/2008 Andreas et al.
 2008/0097299 A1 4/2008 Andreas et al.
 2008/0097574 A1 4/2008 Andreas et al.
 2008/0125850 A1 5/2008 Andreas et al.
 2008/0132989 A1 6/2008 Snow et al.
 2008/0147162 A1 6/2008 Andreas et al.
 2008/0177369 A1 7/2008 Will et al.
 2008/0199510 A1 8/2008 Ruane et al.
 2008/0208311 A1 8/2008 Kao et al.
 2008/0208318 A1 8/2008 Kao et al.
 2008/0234795 A1 9/2008 Snow et al.
 2008/0234798 A1 9/2008 Chew et al.
 2008/0234799 A1 9/2008 Acosta et al.
 2008/0243225 A1 10/2008 Satasiya et al.
 2008/0249607 A1 10/2008 Webster et al.
 2008/0269865 A1 10/2008 Snow et al.
 2009/0076584 A1 3/2009 Mao et al.
 2009/0105686 A1 4/2009 Snow et al.
 2009/0149863 A1 6/2009 Andreas et al.
 2009/0234428 A1 9/2009 Snow et al.
 2009/0248137 A1 10/2009 Andersen et al.
 2009/0248140 A1 10/2009 Gerberding
 2009/0264979 A1 10/2009 Kao et al.
 2009/0276030 A1* 11/2009 Kusleika 623/1.11
 2010/0004729 A1 1/2010 Chew et al.

FOREIGN PATENT DOCUMENTS

DE 199 50 756 8/2000
 DE 101 03 000 8/2002
 EP 0 203 945 B2 12/1986
 EP 0 274 129 B1 7/1988
 EP 0 282 143 9/1988
 EP 0 364 787 A1 4/1990
 EP 0 505 686 9/1992
 EP 0 533 960 3/1993
 EP 0 596 145 5/1994
 EP 0 696 447 A2 2/1996
 EP 0 714 640 A1 6/1996
 EP 0 797 963 A2 10/1997
 EP 0 947 180 10/1999
 EP 1 254 644 A1 11/2002
 EP 1 258 230 11/2002
 EP 1 266 638 B1 12/2002
 EP 1 277 449 1/2003
 EP 1 290 987 A2 3/2003
 EP 1 318 765 A2 6/2003
 EP 1 470 834 10/2004
 EP 1 523 959 A2 4/2005
 EP 1 523 960 A2 4/2005
 GB 2277875 A 11/1994
 JP 03-133446 6/1991

JP 07-132148 5/1995
 JP 10-503663 4/1998
 JP 10-295823 11/1998
 JP 11-503056 T 3/1999
 JP 2935561 B2 8/1999
 JP 2001-190687 7/2001
 JP 2002-538932 T 11/2002
 JP 2004-121343 A 4/2004
 WO 94/27667 A1 12/1994
 WO 95/26695 A2 10/1995
 WO 95/29647 A2 11/1995
 WO 96/26689 9/1996
 WO 96/33677 10/1996
 WO 96/37167 A1 11/1996
 WO 96/39077 A1 12/1996
 WO 97/10778 3/1997
 WO 97/46174 12/1997
 WO 97/48351 12/1997
 WO 98/20810 5/1998
 WO 98/37833 9/1998
 WO 98/58600 12/1998
 WO 99/01087 A1 1/1999
 WO 99/65421 12/1999
 WO 00/12832 A3 3/2000
 WO 00/15151 A1 3/2000
 WO 00/25841 5/2000
 WO 00/32136 6/2000
 WO 00/41649 7/2000
 WO 00/50116 8/2000
 WO 00/51525 A1 9/2000
 WO 00/56237 A2 9/2000
 WO 00/62708 10/2000
 WO 00/72780 12/2000
 WO 01/26707 4/2001
 WO 01/34063 5/2001
 WO 01/70297 9/2001
 WO 01/91918 A1 12/2001
 WO 02/071975 9/2002
 WO 02/085253 A1 10/2002
 WO 02/098326 A1 12/2002
 WO 03/022178 A1 3/2003
 WO 03/021425 6/2003
 WO 03/047651 6/2003
 WO 03/075797 9/2003
 WO 2004/017865 3/2004
 WO 2004/043299 A1 5/2004
 WO 2004/043301 5/2004
 WO 2004/043510 5/2004
 WO 2004/052237 A2 6/2004
 WO 2004/087006 10/2004
 WO 2004/091441 10/2004
 WO 2005/009295 A1 2/2005
 WO 2005/013853 2/2005
 WO 2005/023153 3/2005
 WO 2006/036939 4/2006
 WO 2006/047520 5/2006
 WO 2007/035805 3/2007
 WO 2007/053187 A2 5/2007
 WO 2007/146411 12/2007
 WO 2008/005111 1/2008

OTHER PUBLICATIONS

Colombo, "The Invatec Bifurcation Stent Solution" Bifurcation Stents: Novel Solutions, TCT 2003, Washington: Sep. 15-19, 2003, 24 pages total.
 Cooley et al., "Applications of Ink-Jet Printing Technology to BioMEMs and Microfluidic Systems," Proceedings, SPIE Conference on Microfluidics and BioMEMs, (Oct. 2001).
 "Drug Delivery Stent With Holes Located on Neutral Axis" Research Disclosure, Kenneth Mason Publications, Hampshire, CB, No. 429, Jan. 2000, p. 13.
 Evans Analytical Group, "Functional Sites on Non-polymeric Materials: Gas Plasma Treatment and Surface Analysis," <http://www.eaglabs.com>.
 Joung et al., "Estrogen Release from Metallic Stent Surface for the Prevention of Restenosis," J Control Release. Sep. 19, 2003;92(1-2):83-91.

(56)

References Cited

OTHER PUBLICATIONS

Lefevre et al. "Approach to Coronary Bifurcation Stenting in 2003," Euro PCR, (May 2003) 28 pages total.

"Stent". Definitions from Dictionary.com. Unabridged 9v1.01). Retrieved Sep. 22, 2006, from Dictionary.com website: <<http://dictionary.reference.com/search?q=stent>>.

Stimpson et al., "Parallel Production of Oligonucleotide Arrays Using Membranes and Reagent Jet Printing," BioTechniques 25:886-890 (Nov. 1998).

Tilley , "Biolimus A9-Eluting Stent Shows Promise," Medscape Medical News, Oct. 5, 2004; retrieved from the internet: <<http://www.medscape.com/viewarticle/490621>>, 2 pages total.

Weir et al., "Degradation of poly-L-lactide. Part 2: increased temperature accelerated degradation," Proc Inst Mech Eng H. 2004;218(5):321-30.

U.S. Appl. No. 60/336,607, filed Dec. 3, 2001, first named inventor: Bernard Andreas.

U.S. Appl. No. 60/336,767, filed Dec. 3, 2001, first named inventor: Bernard Andreas.

U.S. Appl. No. 60/336,967, filed Dec. 3, 2001, first named inventor: Sunmi Chew.

U.S. Appl. No. 60/364,389, filed Mar. 13, 2002, first named inventor: Sunmi Chew.

U.S. Appl. No. 60/440,839, filed Jan. 17, 2003, first named inventor: Bernard Andreas.

U.S. Appl. No. 60/561,041, filed Apr. 9, 2004, first named inventor: Jeffrey Grainger.

U.S. Appl. No. 60/784,309, filed Mar. 20, 2006, first named inventor: Bernard Andreas.

U.S. Appl. No. 60/810,522, filed Jun. 2, 2006, first named inventor: Stephen Kaplan.

U.S. Appl. No. 60/890,703, filed Feb. 20, 2007, first named inventor: Patrick Ruane.

Supplementary European Search Report of EP Patent Application No. 07758831, dated Dec. 14, 2009.

Supplementary European Search Report of EP Patent Application No. 05744136, dated Mar. 26, 2008, 3 pages total.

Supplementary European Search Report of EP Patent Application No. 05727731.1, dated Mar. 25, 2008, 2 pages total.

* cited by examiner

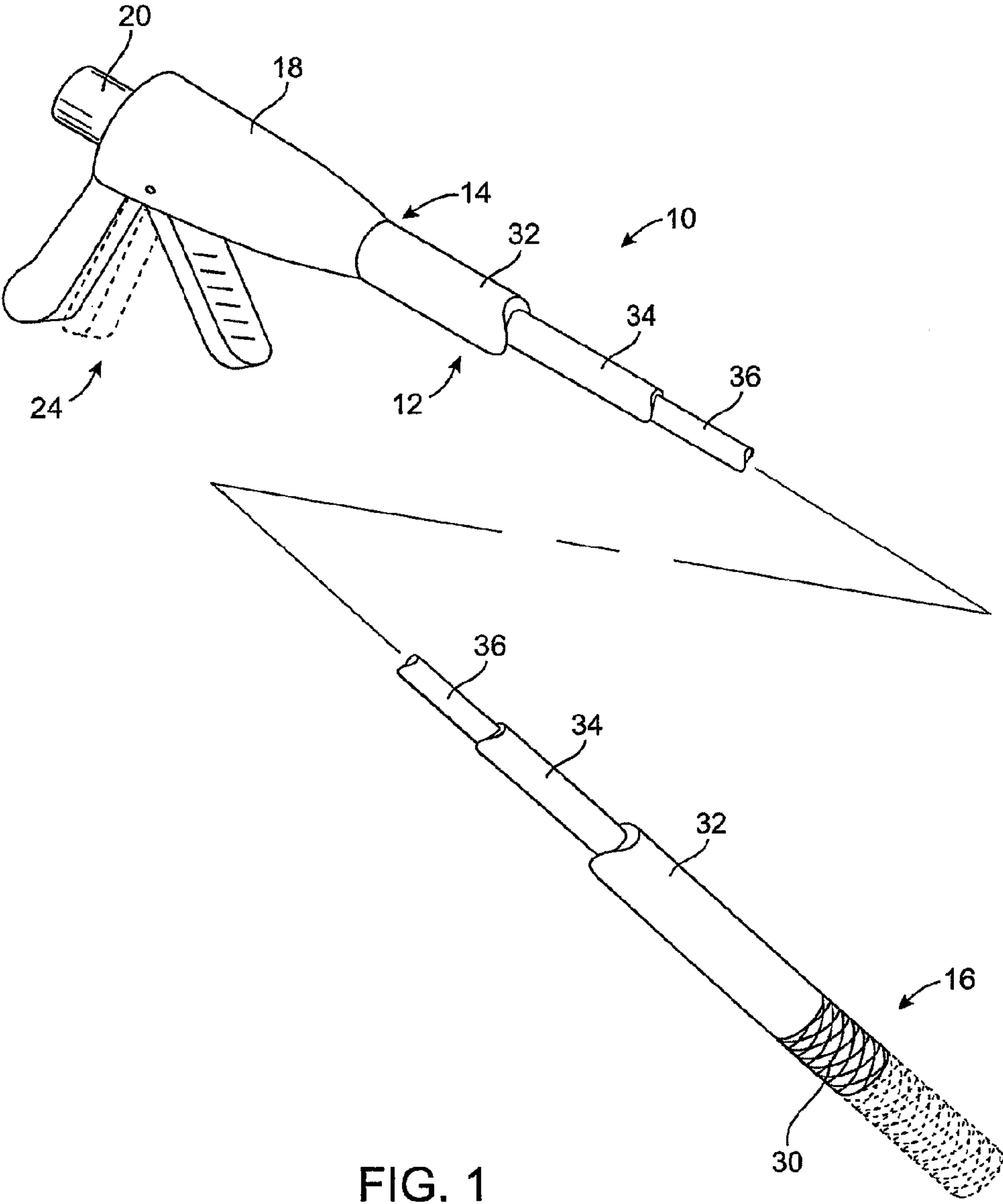
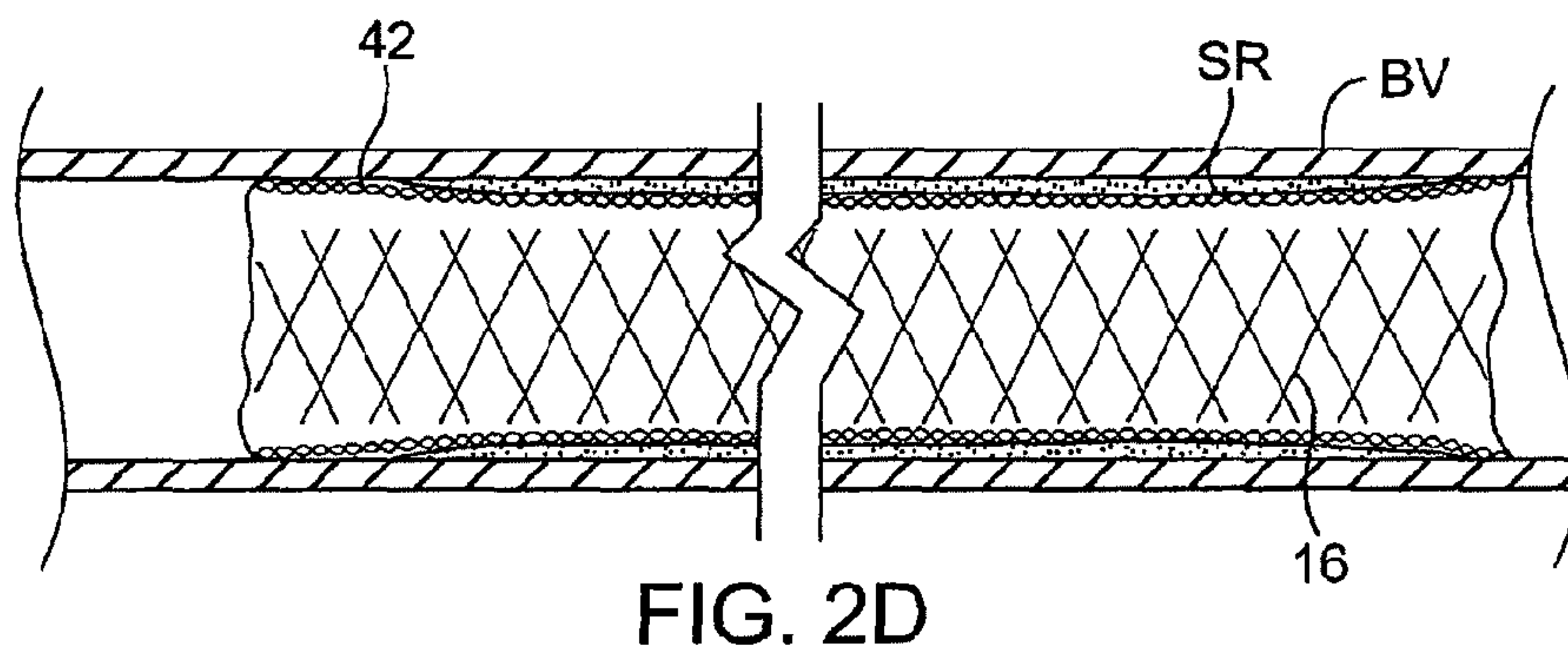
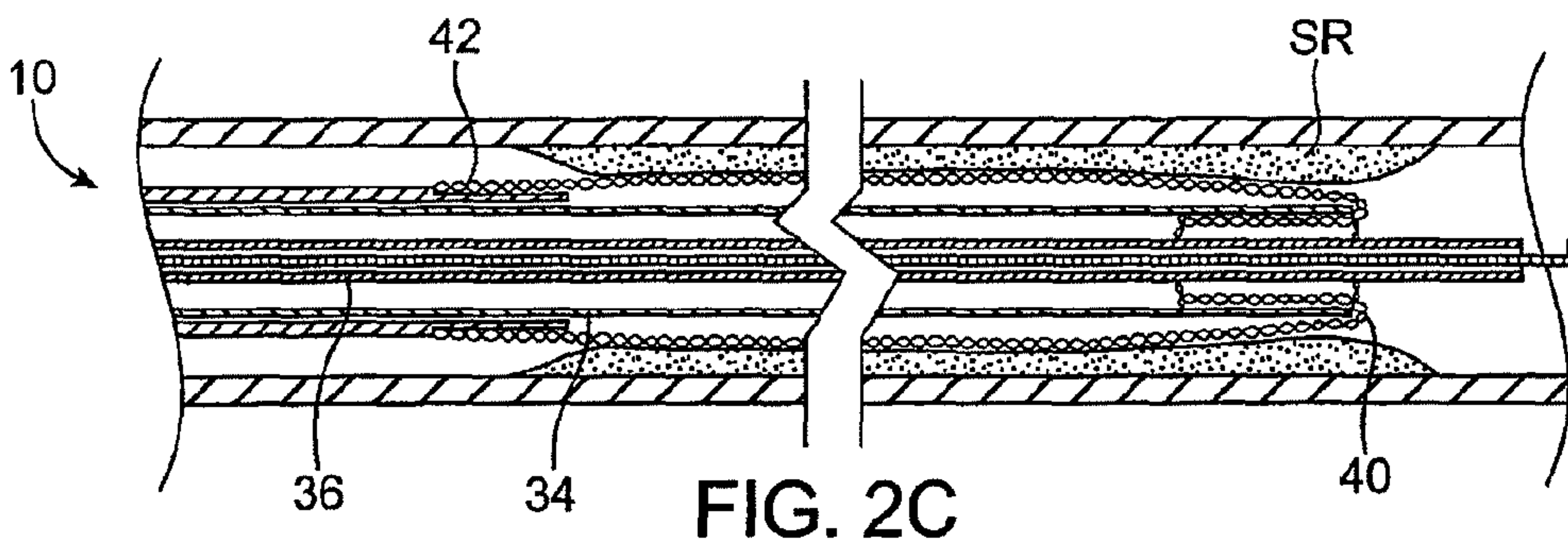
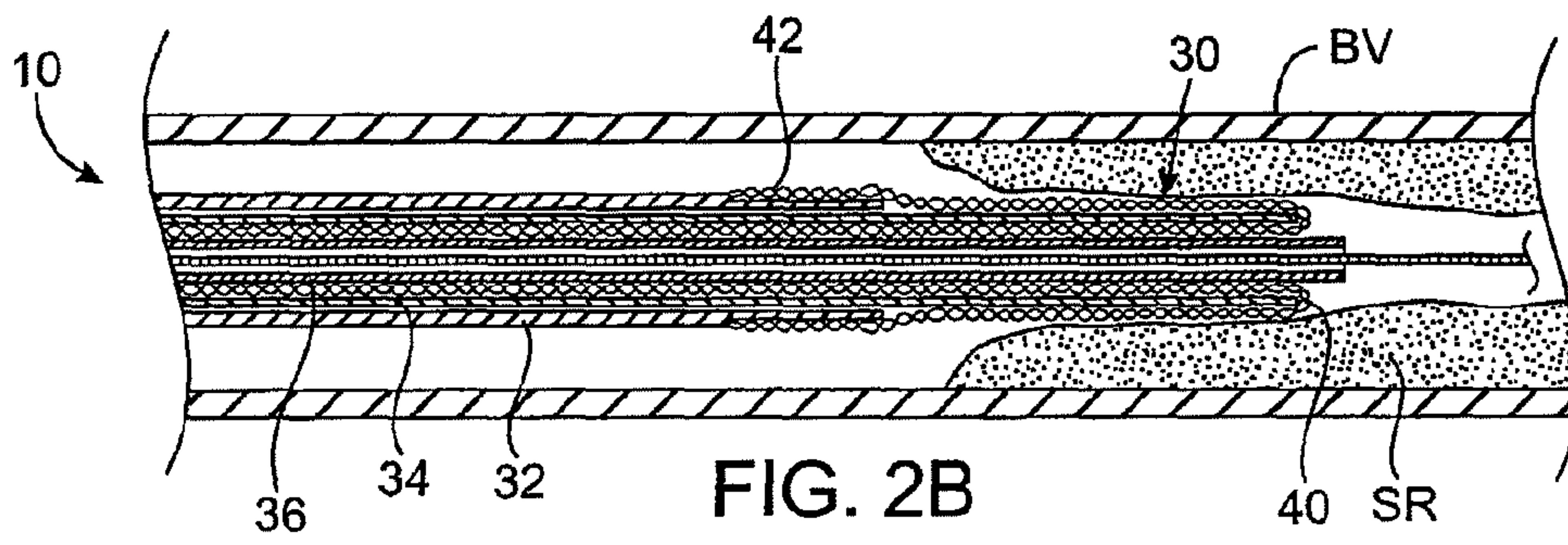
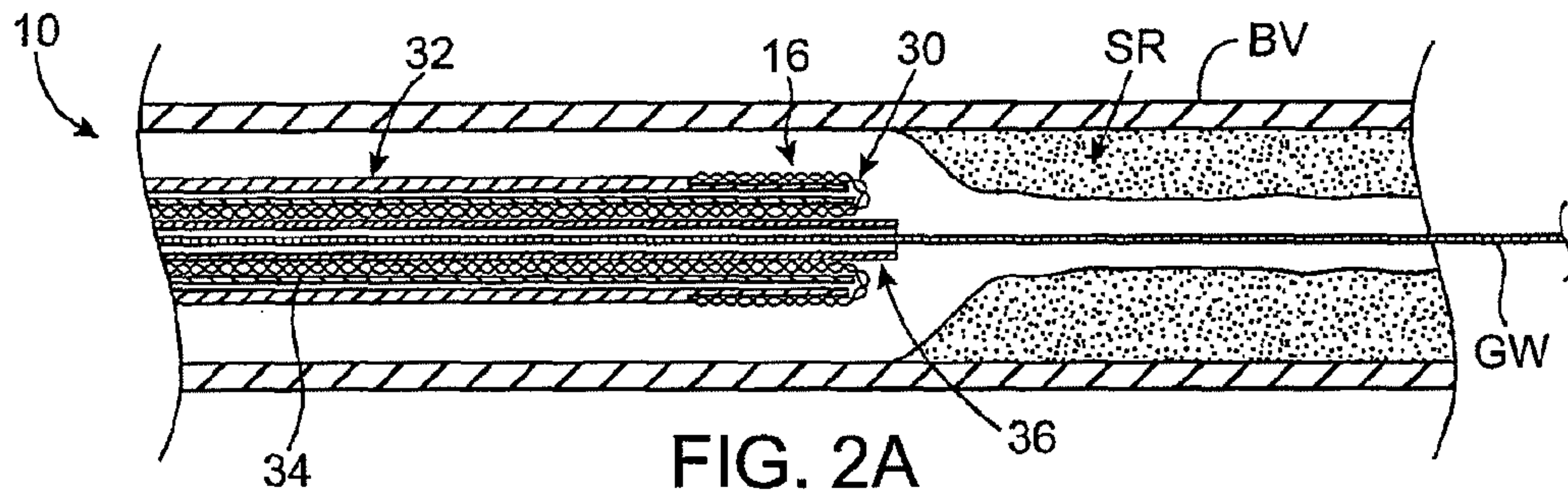

FIG. 1



APPARATUS AND METHODS FOR DELIVERY OF BRAIDED PROSTHESES

CROSS-REFERENCES TO RELATED APPLICATIONS

The present application is a continuation of U.S. patent application Ser. No. 12/040,598, filed Feb. 29, 2008, which is a continuation of U.S. patent application Ser. No. 10/966,806, filed Oct. 14, 2004 (now U.S. Pat. No. 7,357,812 B2), which is a continuation of U.S. patent application Ser. No. 10/306,620, filed Nov. 27, 2002 (now U.S. Pat. No. 7,147,656), which claims priority to U.S. Provisional Patent Application Ser. No. 60/336,607, filed Dec. 3, 2001, the full disclosures of which are incorporated herein by reference.

BACKGROUND OF THE INVENTION

1. Field of the Invention.

The present invention relates generally to medical devices and methods. More particularly, the present invention relates to apparatus and methods for delivering braided and other everting prostheses within a body lumen, such as a blood vessel.

Coronary artery disease is the leading cause of death and morbidity in the United States and Western society. In particular, atherosclerosis in the coronary arteries can cause myocardial infarction, commonly referred to as a heart attack, which can be immediately fatal or even if survived, cause damage to the heart which can incapacitate the patient.

While coronary artery bypass surgery can be an effective treatment for stenosed arteries resulting from atherosclerosis or other causes, it is a highly invasive, costly procedure, which typically requires substantial hospital and recovery time. Percutaneous transluminal coronary angioplasty, commonly referred to as balloon angioplasty, is less invasive, less traumatic, and significantly less expensive than bypass surgery. Heretofore, however, balloon angioplasty has not been considered as effective a treatment as bypass surgery. The effectiveness of balloon angioplasty, however, has improved significantly with the introduction of stenting, which involves the placement of a scaffold structure within the artery which has been treated by balloon angioplasty. The stent inhibits abrupt reclosure of the artery and has some benefit in inhibiting subsequent restenosis resulting from hyperplasia.

Recently, experimental trials have demonstrated that coating stents with anti-proliferative drugs, such as paclitaxel, can significantly reduce the occurrence of hyperplasia in angioplasty treated coronary arteries which have been stented with the coated stents.

While the combination of balloon angioplasty with drug-coated stents holds great promise, significant challenges still remain. Of particular interest to the present invention, the treatment of extended or disseminated disease within an artery remains problematic. Most stents have a fixed length, typically in the range from 10 mm to 30 mm, and the placement of multiple stents to treat disease over a longer length requires the successive use of multiple balloon stent delivery catheters. Moreover, it can be difficult to stent an angioplasty-treated region of a blood vessel with the optimum stent length.

For these reasons, it would be desirable to provide improved stents, stent delivery systems, stenting methods, and the like, for the treatment of patients having coronary artery disease, as well as other occlusive diseases of the vasculature and other body lumens. In particular, it would be desirable to provide stents, delivery systems, and methods for the treatment of disseminated and variable length stenotic

regions within the vasculature. For example, it would be desirable to provide a practical method which permits a physician to deliver extended lengths of braided prostheses to blood vessels and other body lumens. At least some of these objectives will be met by the inventions described hereinafter.

2. Description of the Background Art.

U.S. Pat. No. 5,755,772 describes a tubular prosthesis and method for its implantation by positioning the prosthesis at a target site, and everting an end section to lock the stent after expansion has been completed; and U.S. Pat. No. 5,769,882 describes conformable tubular prostheses and their placement in blood vessels.

BRIEF SUMMARY OF THE INVENTION

The present invention provides methods and apparatus for the stenting of body lumens, typically blood vessels, and more typically coronary arteries. The methods and systems will also find significant use in the peripheral vasculature, the cerebral vasculature, and in other ducts, such as the biliary duct, the fallopian tubes, and the like. The terms "stent" and "stenting" are defined to include any of the wide variety of expandable scaffolds which are designed to be intraluminally introduced to a treatment site and expanded in situ to apply a radially outward force against the inner wall of the body lumen at that site. Stents commonly comprise an open lattice structure, typically formed from a malleable or elastic metal.

The stents of the present invention will comprise evertable structures which radially expand upon eversion to assume a non-collapsible diameter which remains in place within the body lumen to support the luminal wall. Typically, the evertable stent structures will comprise braided structures, but other structures, such as counterwound helices, will also be capable of eversion. In some instances, laser cut helical and other patterned metal tubes, particularly those formed from nickel titanium and other shape memory alloys, may be used. Thin wall tubes formed from polymeric materials, such as polyethylene terephthalate (PET), expanded polytetrafluoroethylene (e PTFE), may also find use, even without patterning.

The braided and other evertable stent structures of the present invention may be formed from metals, including both malleable metals and elastic metals, such as shape memory metals, as well as from polymeric materials. Usually, the braided structures will comprise individual ribbons of the desired material which are interwoven to form a braid so that the braid may be axially elongated to assume a narrow diameter configuration and thereafter be everted to assume a larger diameter configuration. By "evert" it is meant that a leading edge of the prosthesis is turned outwardly and backwardly relative to the narrow diameter portion thereof. In the preferred methods and apparatus of the present invention, as described in more detail below, such eversion will be achieved by initially holding the prosthesis in its narrow diameter configuration with the leading portion everted and fixed to an outer portion of a catheter. This leading portion is referred to as the "fixed end." The remainder of the prosthesis which remains in its narrow diameter configuration is held within a passage or lumen of a delivery catheter, and means are provided for pushing the "advanceable end" of the prosthesis which is in the lumen forwardly relative to the fixed end. In this way, the leading edge of the prosthesis moves forward continuously relative to the fixed end as it everts radially outwardly.

The use of such braided and other evertable prostheses provides a number of advantages. For example, the braided structure is highly flexible, particularly in its narrow diameter

configuration, allowing the introduction of relatively long stent segments without significantly limiting the ability of the delivery catheter to pass through torturous regions of the vasculature or other body lumens. Additionally, by everting the prosthesis so that its outer portion remains stationary 5 relative to the fixed end (and thus also relative to the delivery catheter), the stent will be able to pass through relatively small body lumens since it advances much like a tractor tread in moving forwardly through the lumen. In the case of vascular treatments, the stents of the present invention will usually be used following other primary interventions, such as angioplasty, atherectomy, aneurysm repair, or the like. It will be possible, however, in certain instances, to deliver the stent without prior intervention because of the ability to advance through tight lesions and to dilate the lesion as it passes therethrough. 15

Usually, the methods and apparatus of the present invention will be used to deliver a single stent having a predetermined length. In other instances, however, it will be possible to provide a means for severing the stent on the catheter itself. In such cases, the methods and apparatus of the present invention will be capable of delivering variable lengths of stent depending on the nature and extent of the disease being treated. That is, the apparatus will be used to deliver the stent under fluoroscopic or other observation, and after a desired length of stent has been deployed, the deployed length can be severed from the length which remains carried within the delivery catheter. 25

In one aspect of the present invention, a method for delivering a prosthesis to a body lumen comprises positioning a metallic tubular prosthesis at a target site within the body lumen. The prosthesis is then everted so that an inside surface is exposed radially outwardly and advanced over a length of the wall of the body lumen. Usually, positioning comprises introducing a delivery catheter having a passage which carries the tubular prosthesis at least partly in a radially collapsed configuration. Everting usually comprises pushing the tubular prosthesis from the catheter so that a leading portion of the prosthesis everts and radially expands as it exits the catheter or passage. This is usually accomplished by forwardly advancing a portion of the catheter to push the prosthesis from the catheter. In a preferred aspect of the present invention, an advanceable segment of the prosthesis is carried in the passage in the radially collapsed configuration. A fixed end of the prosthesis is held stationary relative to the catheter in a partially everted configuration. Everting then comprises pushing a proximal end (i.e., an end or portion of the prosthesis which is radially collapsed within the delivery catheter) to cause a middle portion of the prosthesis to progressively evert and advance distally relative to the fixed end. In the case of braided prostheses, the braided structure will shorten as the radius expands so that the "advanceable" proximal end prosthesis is pushed forward at a rate which is faster than the rate at which the everted prosthesis covers the wall of the body lumen. In preferred embodiments, the prosthesis releases an active substance which inhibits hyperplasia after the prosthesis has been placed in the body lumen. 50

In another aspect of the present invention, a method for delivering a stent to a blood vessel comprises positioning the stent at a target site within the blood vessel and everting the stent so that an inside surface is exposed radially outwardly and advanced over a length of a wall of the blood vessel. The stent, in turn, inhibits restenosis in the blood vessel. 60

In another aspect of the present invention, a method for delivering a prosthesis to a body lumen involves positioning a tubular prosthesis at a target site within the body lumen, the tubular prosthesis having a total length. The tubular prosthe-

sis is then everted so that an inside surface is exposed radially outwardly and a desired length of the tubular prosthesis is advanced over a length of a wall of the body lumen, the desired length being less than the total length. The method then includes severing a portion of the tubular prosthesis having the desired length to allow the portion to remain in the body lumen. 5

In another aspect of the present invention, a method for delivering a prosthesis to a body lumen involves positioning a delivery catheter carrying a tubular prosthesis at a target site within the body lumen, everting the tubular prosthesis so that an inside surface is exposed radially outwardly and advanced over a desired length of a wall of the body lumen, and deploying a portion of the tubular prosthesis having the desired length. A second length of the tubular prosthesis remains carried within the delivery catheter. 10

In another aspect of the present invention, an apparatus for delivering a prosthesis to a body lumen includes a catheter having a passage, a metallic tubular prosthesis carried in the passage at least partially in a radially collapsed configuration, and a slidable member in the catheter for advancing the prosthesis from the passage so that the prosthesis everts and radially expands as it is advanced. In some embodiments, the metallic tubular prosthesis is a shape memory metal. In some 25 embodiments, the metallic tubular prosthesis comprises a braided metal structure. Alternatively, the metallic tubular prosthesis may comprise an open lattice structure.

In yet another embodiment of the present invention, an apparatus for delivering a prosthesis to a blood vessel includes a catheter having a passage, a stent carried in the passage at least partially in a radially collapsed configuration, and a slidable member in the catheter for advancing the prosthesis from the passage so that said prosthesis everts and radially expands as it is advanced. The stent is configured to inhibit restenosis in the blood vessel. 30

In another aspect of the invention, an apparatus for delivering a prosthesis to a body lumen includes a catheter having a passage, a tubular prosthesis carried in the passage at least partially in a radially collapsed configuration, a slidable member in the catheter for advancing the prosthesis from the passage so that said prosthesis everts and radially expands as it is advanced, and a severing member in the catheter for severing a portion of the prosthesis to allow the portion to remain in the body lumen while a second portion of the prosthesis remains carried in the catheter. 40

These and other aspects and embodiments of the present invention will be described in further detail below, with reference to the attached drawing figures. 45

BRIEF DESCRIPTION OF THE DRAWINGS

FIG. 1 is a perspective view illustrating a stent delivery catheter constructed in accordance with the principles of the present invention. 55

FIGS. 2A-2D illustrate use of the catheter in FIG. 1 for deploying a braided stent within a stenosed region in a blood vessel.

DETAILED DESCRIPTION OF THE INVENTION

Referring now to FIG. 1, the stent delivery catheter 10 comprises a catheter body 12 having a proximal end 14 and a distal end 16. The catheter body 12 is formed from a conventional catheter material, such as a natural or synthetic polymer, such as silicone rubber, polyethylene, polyvinylchloride, polyurethane, polyester, polytetrafluoroethylene, nylon, and the like. The body may be formed as a composite having 65

5

one or more reinforcement layers incorporated within a polymeric shell in order to enhance strength, flexibility, and toughness. For intravascular use, the catheter body will typically have a length in the range from 40 cm to 150 cm, usually being between 40 cm and 120 cm for peripheral blood vessels and between 110 cm and 150 cm for coronary arteries. The outer diameter of the catheter body may vary depending on the intended use, typically being between 3 French and 15 French, usually from 5 French to 9 French (one French=0.33 mm).

Catheter **10** further comprises a handle **18** at its proximal end **14**. The handle has a guidewire port **20** at its distal end as well as a handle grip **24** which is actuatable to extend and release evertible prosthesis **30** from the distal end **16**. The catheter body **12** comprises an outer tube **32**, a middle tube **34** which is coaxially and slidably mounted within a lumen of the outer tube **32**, and an inner tube **36** which is slidably and coaxially mounted within a lumen of the middle tube **34**. Inner tube **36** has a central lumen for receiving a guidewire, as described in detail below.

Referring now to FIGS. 2A-2D, delivery of the prosthesis **30** within a stenosed region SR of a blood vessel BV is described. The distal end **16** of the catheter **10** is introduced over a guidewire GW to the stenosed region SR as shown in FIG. 2A.

At that point, the prosthesis **30** is advanced forwardly or distally into the stenosed region SR of the blood vessel BV, as shown in FIG. 2B. In particular, both the inner tube **36** and the middle tube **34** are advanced forwardly or distally relative to the outer tube **32**. This causes the leading edge **40** of the prosthesis **30** to advance into the stenosed region SR, engaging and partially dilating the lumen wall within this region.

As the inner tube **36** and middle tube **34** are further advanced, as shown in FIG. 2C, the leading edge **40** of the prosthesis advances out through the other end of the stenosed region SR. During this entire deployment, fixed end **42** of the prosthesis has remained on the distal end of the outer tube **32** of the delivery catheter **10**.

Once the prosthesis **30** is fully deployed, the outer tube **32** would be disengaged from the fixed end **42** of the prosthesis, e.g., by rotating or otherwise separating the catheter from the prosthesis, leaving the prosthesis **30** in place, as shown in FIG. 2D. As can be seen in FIG. 2D, the deployment of the prosthesis **30** has dilated the stenotic region. At this point, if the dilation is insufficient, or further anchoring of the prosthesis **30** is desired, a balloon or other expandable member may be expanded within the prosthesis **30** in a conventional manner. In one embodiment, for example, a balloon may be coupled with the outer tube **32** in such a way as to allow the balloon to be inflated to further anchor the prosthesis **30** in place.

It will be appreciated that the lengths, pitches, adjacent spacings, and the like, of the braided and other elements deployed according to the methods of the present invention

6

can be controlled at the discretion of the treating physician. Thus, the methods and apparatus of the present invention provide useful flexibility for the treating physician to treat extended and disseminated disease in the vasculature and other body lumens.

Although the foregoing invention has been described in some detail by way of illustration and example, for purposes of clarity of understanding, it will be obvious that certain changes and modifications may be practiced within the scope of the appended claims.

What is claimed is:

1. A method for delivering a prosthesis to a body lumen, said method comprising:

positioning a delivery catheter at a target site, the tubular catheter comprising:

an outer tube having a passage;

a tubular prosthesis carried in the passage of the outer tube at least partially in a radially collapsed configuration; and

an inner tube slidably disposed within the passage of the outer tube, the inner tube having a lumen for receiving a guidewire; and

advancing the inner tube distally relative to the outer tube to evert the tubular prosthesis so that an inside surface is exposed radially outwardly and advanced over a length of a wall of the body lumen.

2. The method of claim **1**, further comprising radially expanding the tubular prosthesis with an expandable member of the delivery catheter so that the tubular prosthesis applies a radially outward force against inner wall.

3. The method of claim **1**, further comprising severing the tubular prosthesis with a separation element so that a first portion of the tubular prosthesis is deployed at the target site while another portion of the tubular prosthesis remains carried in the passage.

4. The method of claim **1**, further comprising operating a handle at a proximal end of the delivery catheter to advance the inner tube to evert the tubular prosthesis.

5. The method of claim **1**, further comprising inflating a balloon so as to anchor the tubular prosthesis to the body lumen.

6. The method of claim **1**, wherein the delivery catheter further comprises a middle tube slidably disposed within the passage of the outer tube and slidably disposed over the inner tube, and wherein the method further comprises advancing the middle tube with the inner tube to evert the tubular prosthesis.

7. The method of claim **1**, further comprising releasing a therapeutic agent from the tubular prosthesis after deployment thereof.

8. The method of claim **7**, wherein the therapeutic agent inhibits restenosis.

* * * * *