

US008568174B2

(12) **United States Patent**
Liu

(10) **Patent No.:** **US 8,568,174 B2**
(45) **Date of Patent:** **Oct. 29, 2013**

(54) **CARD CONNECTOR**

7,556,534 B1 * 7/2009 Ho 439/630
8,038,477 B2 * 10/2011 Zhang 439/630
8,337,252 B2 * 12/2012 Mambakkam et al. 439/630

(75) Inventor: **Zhu-Rui Liu**, Guang-Dong (CN)

* cited by examiner

(73) Assignee: **Cheng UEI Precision Industry Co., Ltd.**, New Taipei (TW)

Primary Examiner — Phuong Dinh

(*) Notice: Subject to any disclaimer, the term of this patent is extended or adjusted under 35 U.S.C. 154(b) by 0 days.

(74) *Attorney, Agent, or Firm* — Cheng-Ju Chiang

(21) Appl. No.: **13/405,231**

(22) Filed: **Feb. 24, 2012**

(65) **Prior Publication Data**

US 2013/0225003 A1 Aug. 29, 2013

(51) **Int. Cl.**
H01R 24/00 (2011.01)

(52) **U.S. Cl.**
USPC **439/630**

(58) **Field of Classification Search**
USPC 439/630, 188, 159, 540.1
See application file for complete search history.

(56) **References Cited**

U.S. PATENT DOCUMENTS

6,056,601 A * 5/2000 Pollock et al. 439/630
7,238,051 B2 * 7/2007 Miyawaki et al. 439/630

(57) **ABSTRACT**

A card connector for receiving a micro-SIM card and a micro-SD card therein includes an insulating housing, a plurality of signal terminals and conductive terminals, and a supporting tray. The insulating housing defines an accommodating chamber. The signal terminals are disposed in the insulating housing with contact portions thereof projecting into the accommodating chamber. The conductive terminals are disposed in the insulating housing with touching portions thereof projecting into the accommodating chamber. The supporting tray defines a first receiving space and a second receiving space for receiving the micro-SIM card and the micro-SD card therein respectively. The supporting tray together with the micro-SIM card and the micro-SD card is inserted into the accommodating chamber. Bottoms of the first receiving space and second receiving space are opened freely to make the micro-SIM card electrically contact with the contact portions and the micro-SD card electrically contact with the touching portions.

5 Claims, 5 Drawing Sheets

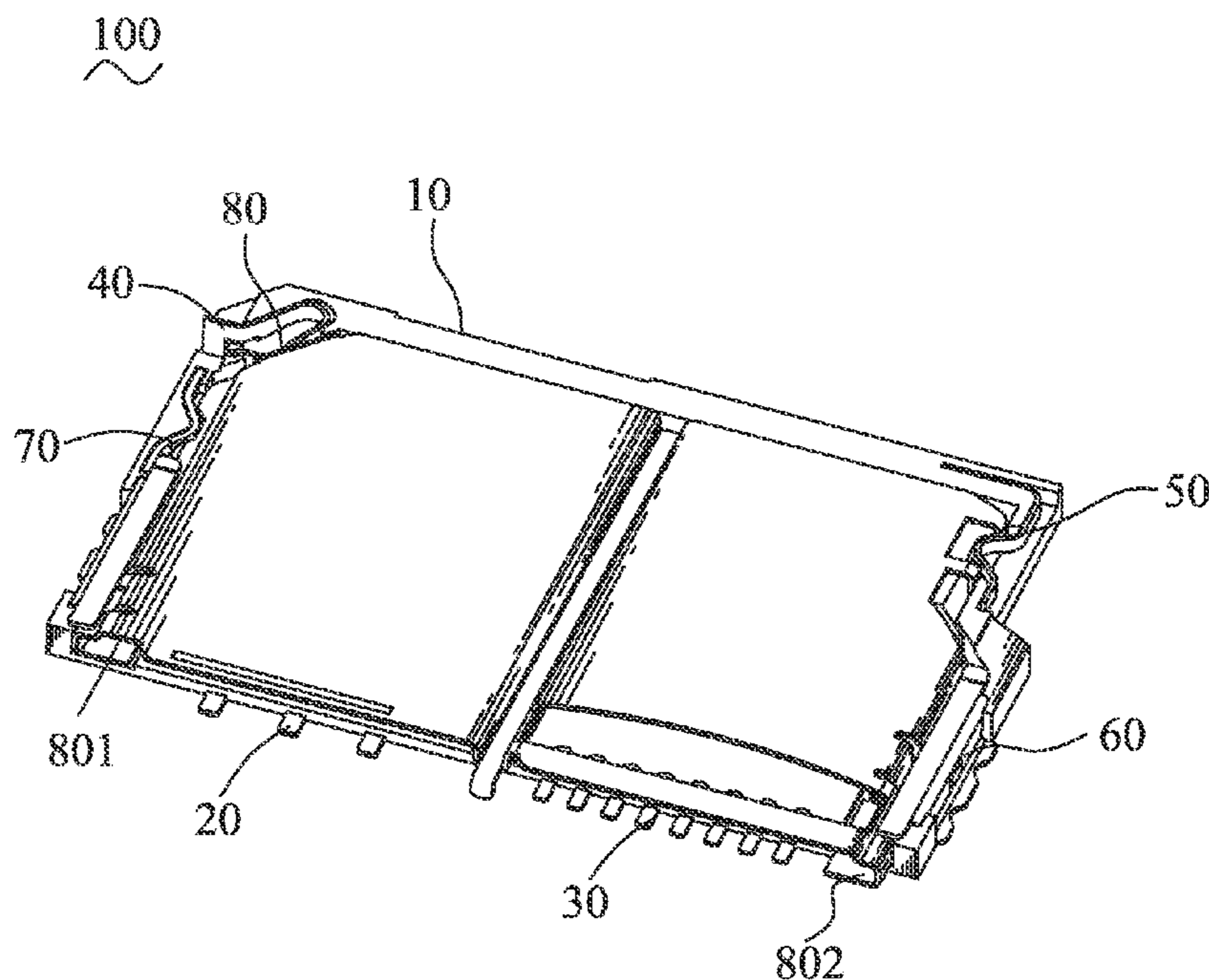

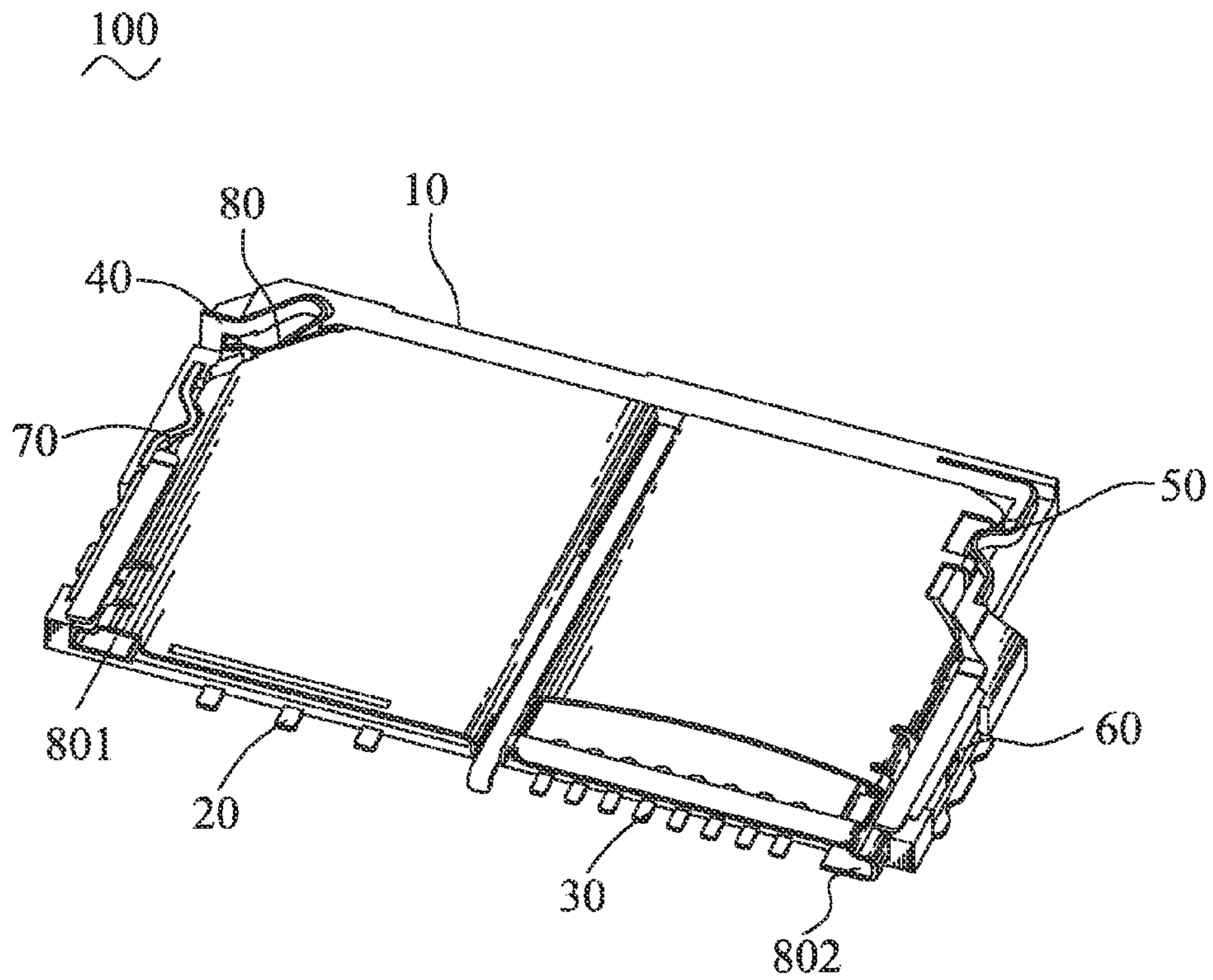

FIG. 1

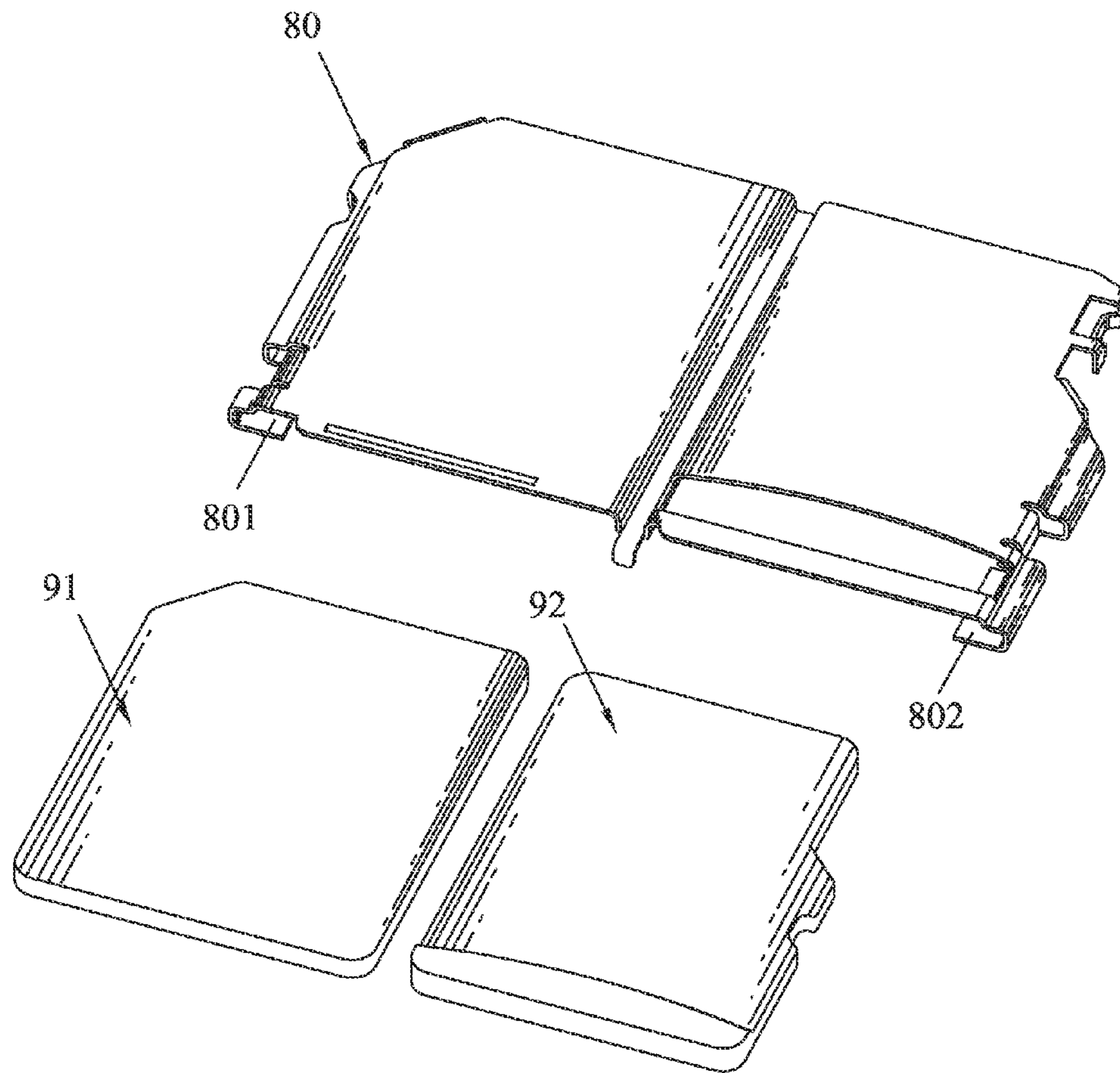

FIG. 3

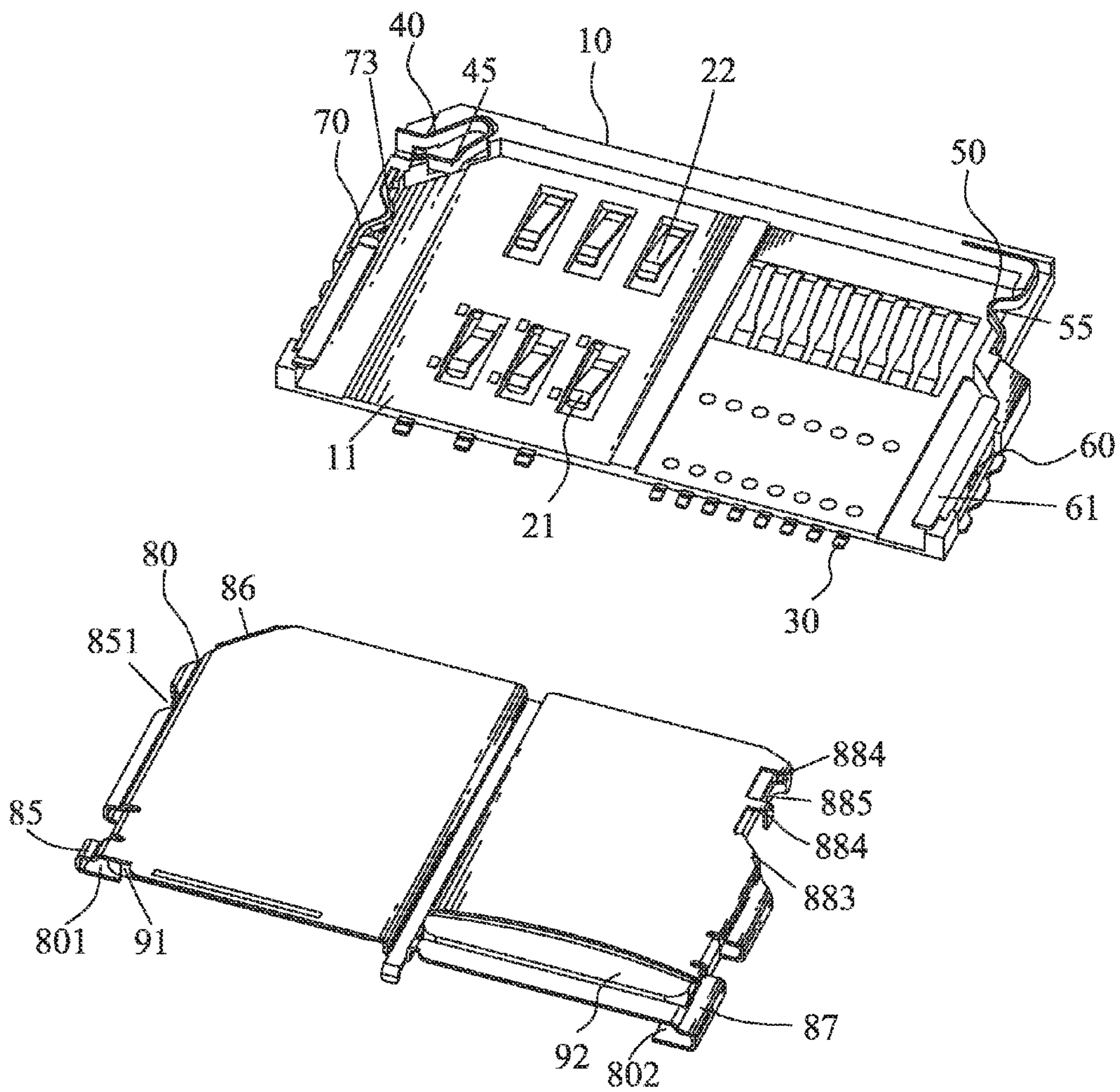

FIG. 4

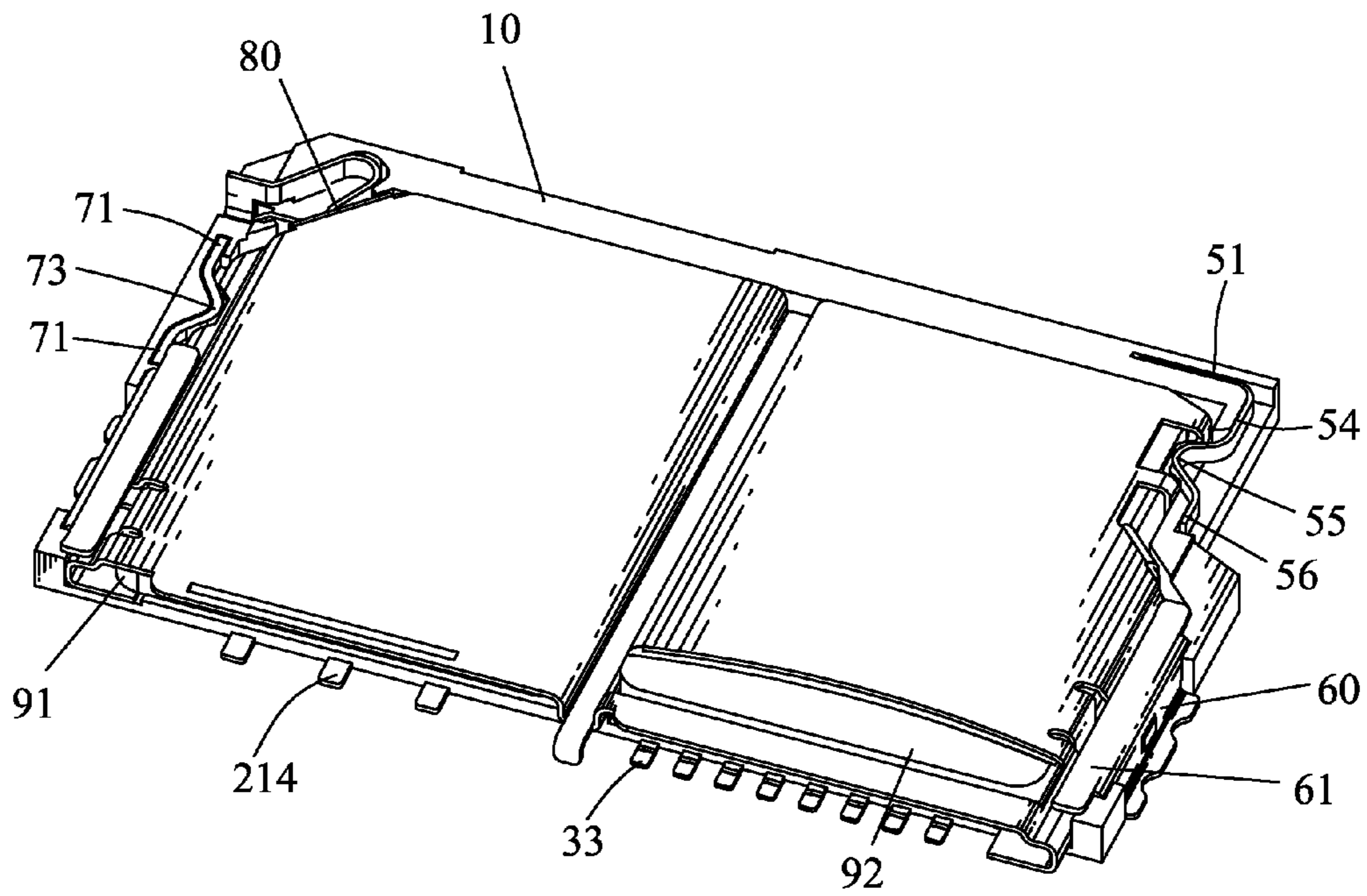

FIG. 5

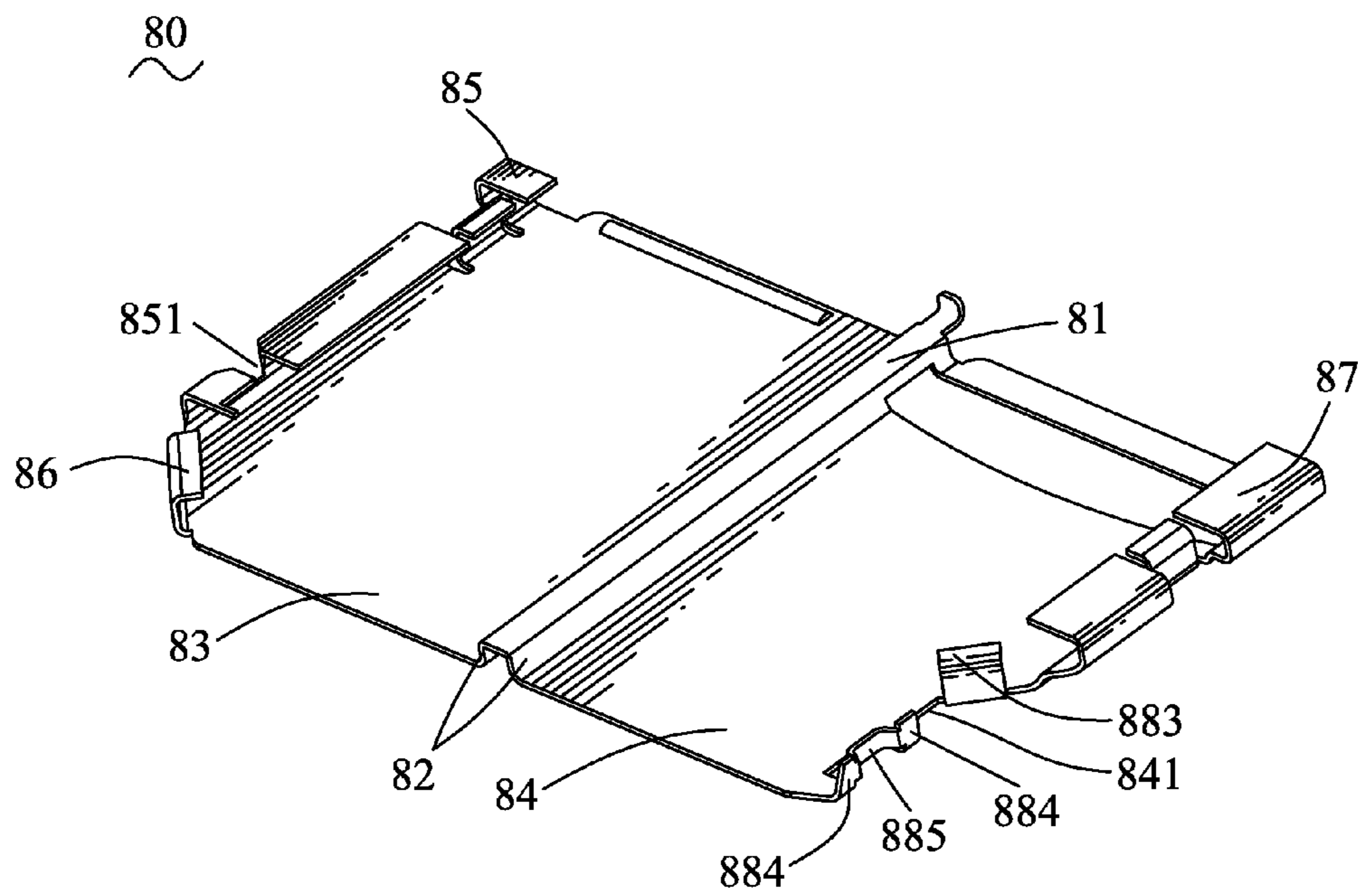

FIG. 6

1

CARD CONNECTOR

BACKGROUND OF THE INVENTION

1. Field of the Invention

The present invention generally relates to a card connector, and more particularly to a card connector capable of receiving a micro-SIM (Subscriber Identity Module) card and a micro-SD (Secure Digital) card therein simultaneously.

2. The Related Art

A conventional card connector adapted for receiving a micro-SIM card and a micro-SD card therein includes an insulating housing, a plurality of first terminals and second terminals. The insulating housing defines a first accommodating chamber and a second accommodating chamber. The insulating housing further defines a plurality of first terminal grooves communicating with the first accommodating chamber, and a plurality of second terminal grooves communicating with the second accommodating chamber. The first terminals are disposed in the first terminal grooves and further project into the first accommodating chamber. The second terminals are disposed in the second terminal grooves and further project into the second accommodating chamber. When the card connector is in use, the micro-SIM card and the micro-SD card should be inserted into the first accommodating chamber and the second accommodating chamber in sequence that results in an inconvenient insertion of the micro-SIM card and the micro-SD card into the card connector.

SUMMARY OF THE INVENTION

An object of the present invention is to provide a card connector adapted for receiving a micro-SIM card and a micro-SD card therein includes an insulating housing, a plurality of signal terminals, a plurality of conductive terminals and a supporting tray. The insulating housing has a base board, a first side wall and a second side wall protruding upward from two opposite sides of the base board, and a rear wall connecting with rear ends of the first side wall and the second side wall. An accommodating chamber is formed among the base board, the first side wall, the second side wall and the rear wall. One side of the base board defines two rows of openings communicating with one side of the accommodating chamber. A rear of the other side of the base board defines a window communicating with the other side of the accommodating chamber. The signal terminals are disposed in the insulating housing with contact portions thereof projecting into the one side of the accommodating chamber through the openings respectively. The conductive terminals are disposed in the insulating housing with touching portions thereof projecting into the other side of the accommodating chamber through the window. The supporting tray defines a first receiving space and a second receiving space with front ends thereof being opened freely for receiving the micro-SIM card and the micro-SD card therein, respectively. The supporting tray together with the micro-SIM card and the micro-SD card is inserted into the accommodating chamber of the insulating housing. Bottoms of the first receiving space and the second receiving space are further opened freely to make the micro-SIM card electrically contact with the contact portions of the signal terminals and the micro-SD card electrically contact with the touching portions of the conductive terminals.

As described above, the supporting tray together with the micro-SIM card and the micro-SD card is inserted in the accommodating chamber of the insulating housing to make

2

the micro-SIM card and the micro-SD card insert in the card connector simultaneously so as to facilitate the micro-SIM card and the micro-SD card for being assembled in the card connector. Furthermore, the first receiving space and the second receiving space of the supporting tray for receiving the micro-SIM card and the micro-SD card respectively are disposed side by side to lower a thickness of the card connector.

BRIEF DESCRIPTION OF THE DRAWINGS

The present invention will be apparent to those skilled in the art by reading the following description, with reference to the attached drawings, in which:

FIG. 1 is a perspective view of a card connector in accordance with the present invention;

FIG. 2 is an exploded view of the card connector of FIG. 1;

FIG. 3 is a perspective view of a micro-SIM card, a micro-SD card and a supporting tray of the card connector of FIG. 1, wherein the micro-SIM card, the micro-SD card and the supporting tray are apart from one another;

FIG. 4 is a partially exploded view of the card connector of FIG. 1, wherein the supporting tray together with the micro-SIM card and the micro-SD card is disassembled from the card connector;

FIG. 5 is an assembling view of the card connector of FIG. 1, and the micro-SIM card and the micro-SD card; and

FIG. 6 is a perspective view of the supporting tray of the card connector of FIG. 2.

DETAILED DESCRIPTION OF THE PREFERRED EMBODIMENT

With reference to FIGS. 1-3, a card connector **100** in accordance with the present invention is shown. The card connector **100** adapted for receiving a micro-SIM card **91** and a micro-SD card **92** therein includes an insulating housing **10**, a plurality of signal terminals **20**, a plurality of conductive terminals **30**, a first switch terminal **40**, a second switch terminal **50**, two fastening elements **60**, a limiting element **70** and a supporting tray **80**.

Referring to FIG. 2 and FIG. 4, the insulating housing **10** has a base board **11** of a substantial rectangular shape, a first side wall **12** and a second side wall **13** protruding upward from two opposite sides of the base board **11**, and a rear wall **14** protruding upward from a rear of the base board **11** and connecting with rear ends of the first side wall **12** and the second side wall **13**. An accommodating chamber **15** is formed among the base board **11**, the first side wall **12**, the second side wall **13** and the rear wall **14**. A separating block **111** protrudes upward and extends longitudinally from a substantial middle of the base board **11** to divide the accommodating chamber **15** into a first accommodating chamber **151** and a second accommodating chamber **152**. One side of the base board **11** defines two rows of openings **16** located at a front thereof and at a rear thereof respectively, and communicating with the first accommodating chamber **151**. Each row of the openings **16** is arranged along a transverse direction. A rear of the other side of the base board **11** defines a window **17** communicating with the second accommodating chamber **152**.

A corner between the first side wall **12** and the rear wall **14** defines a first switch terminal groove **121** which includes a receiving groove **1211** concaved downward in a top of the corner between the first side wall **12** and the rear wall **14** and communicating with the first accommodating chamber **151**, a notch **1212** being cut off in one side of a bottom sidewall of the receiving groove **1211** adjacent to the first side wall **12** and

passing through the first side wall **12**, and an insertion slot **1213** penetrating through an innermost side of the bottom sidewall of the receiving groove **1211**. The first side wall **12** defines a limiting terminal groove **122** which includes two holding grooves **1221** concaved downward in two portions of a top of the first side wall **12**, and two fastening slots **1222** extending oppositely from two opposite sides of the two holding grooves **1221**. An arc-shaped protrusion **1223** is protruded into the first accommodating chamber **151** from an inner side surface of the first side wall **12** and located between the two holding grooves **1221**. A bottom of each fastening slot **1222** extends downward to form a fastening fillister (not shown).

The first side wall **12** and the second side wall **13** respectively defines a fastening groove **131** which includes a passage **1311** extending vertically to penetrate through an outside of a front of the first side wall **12** or the second side wall **13**, and two clipping slots **1312** extending oppositely from two opposite sides of the passage **1311**. A buckling portion **1313** is protruded outward from an innermost sidewall of each passage **1311**. The insulating housing **10** defines a second switch terminal groove **132** which includes a fastening slit **1321** opened in a top of one end of the rear wall **14** adjacent to the second side wall **13**, an accommodating groove **1322** opened in an outer side of a rear of the second side wall **13** and a connecting groove **1323** connecting with a middle of an inner side of the accommodating groove **1322**. A bottom of the rear wall **14** defines an inserting slot (not shown) communicating with a middle of a bottom of the fastening slit **1321**.

Referring to FIG. 2, the signal terminals **20** include a plurality of first signal terminals **21** and a plurality of second signal terminals **22**. Each of the first signal terminals **21** has an inverted L-shaped first fastening portion **211** from a top view. The fastening portion **211** has a first arm **2111** disposed longitudinally, and a second arm **2112** perpendicular to the first arm **2111**. A front of one side of the first arm **2111** extends sideward to form a second fastening portion **212** located at a same side as that of the second arm **2112**. One side of the second arm **2112** is inclined upward and forward, and then arched upward to form a first contact portion **213**. A front end of the first arm **2111** is inclined downward and forward, and then extends forward to form a first soldering portion **214**. Each of the second signal terminals **22** has a third fastening portion **221**. Two middles of two opposite sides of the third fastening portion **221** are inclined upward and sideward to form two enforcing portions **222**. A front end of the third fastening portion **221** is inclined upward and forward and then arched upward to form a second contact portion **223**. A rear end of the third fastening portion **221** is inclined downward and rearward, and then extends rearward to form a second soldering portion **224**.

Referring to FIG. 2, each of the conductive terminals **30** has an elongated locating portion **31**. A rear end of the locating portion **31** is inclined upward and rearward, and then is arched upward to form a touching portion **32**. A middle of a front end of the locating portion **31** extends forward, then is inclined downward and forward and further extends forward to form a soldering foot **33**.

Referring to FIG. 2, the first switch terminal **40** has a first base arm **41** disposed vertically. One side of a bottom of the first base arm **41** is bent forward to form a first soldering arm **42**. One end of the first base arm **41** away from the first soldering arm **42** is smoothly inclined rearward and sideward to form a first fastening arm **43**. A middle of a bottom of the first fastening arm **43** protrudes downward to form an insertion arm **47**. An obtuse angle is shown between the first

fastening arm **43** and the first base arm **41**. A free end of the first fastening arm **43** is bent sideward and then slantwise extends forward to form a first elastic arm **44** away from the first base arm **41**. A free end of the first elastic arm **44** is arched outward to form a first touching arm **45**. A free end of the first touching arm **45** extends along a same extending direction as that of the free end of the first elastic arm **44** to form a first restraining arm **46**.

Referring to FIG. 2, the second switch terminal **50** has an elongated second base arm **51**. One end of a bottom of the second base arm **51** protrudes downward and bends rearward to form a second soldering arm **52**. A middle of the bottom of the second base arm **51** protrudes downward to form a second fastening arm **53**. One end of the second base arm **51** away from the second soldering arm **52** bends forward to form a second elastic arm **54**. A free end of the second elastic arm **54** is arched sideward to form a second touching arm **55** located in front of the second base arm **51**. A free end of the second touching arm **55** extends forward to form a second restraining arm **56**.

Referring to FIG. 2, each of the fastening elements **60** has an elongated pressing plate **61** at a top thereof. A middle of one side of the pressing plate **61** bends downward to form a T-shaped connecting plate **62** from a side view. The connecting plate **62** defines a buckling hole **621**. A bottom of the connecting plate **62** bends opposite to the pressing plate **61** to form a soldering plate **63**. The limiting element **70** has an arc-shaped resisting portion **73**. Two opposite ends of the resisting portion **73** extend oppositely to form two fastening strips **71**. Two bottoms of the two fastening strips **71** extend downward to form two insertion strips **72**.

Referring to FIG. 2 again, the supporting tray **80** has an elongated base plate **81**. Two opposite sides of the base plate **81** bend upward to form two elongated lateral plates **82**. Two tops of the two lateral plates **82** extend oppositely to form a first top plate **83** and a second top plate **84**. A plurality of first clamping plates **85** of substantial U-shaped from a front view is connected with a free side edge of the first top plate **83** with the mouths thereof facing the corresponding lateral plate **82** at a distance. A notch **851** is formed between two of the first clamping plates **85** and located at a rear of the first top plate **83**. A free corner at the rear of the first top plate **83** is bent downward, and then bent inward to form a blocking tail **86**. A first receiving space **801** is formed among the first top plate **83**, the corresponding lateral plate **82**, the first clamping plates **85** and the blocking tail **86**.

A plurality of second clamping plates **87** of substantial U-shaped from the front view is connected with a free side edge of the second top plate **84** with the mouths thereof facing the corresponding lateral plate **82** at a distance. A rear of the free side of the second top plate **84** is cut off to define a right-angle trapezoid gap **841** passing through the rear end of the free side of the second top plate **84**. The gap **841** has a straight sidewall **881** substantially extending longitudinally, and a tilted sidewall **882** connecting between a front end of the straight sidewall **881** and the free side edge of the second top plate **84**. The tilted sidewall **882** of the gap **841** extends downward, and then bends inward to form a blocking plate **883**. Two portions of the straight sidewall **881** protrude outward and then bend downward to form two propping arms **884**. Two free ends of the two propping arms **884** are inclined towards each other and then extend towards each other to form a resisting arm **885**. A second receiving space **802** is formed among the second top plate **84**, the corresponding lateral plate **82**, the second clamping plates **87**, the blocking

5

plate **883**, the propping arms **884** and the resisting arm **885**. The second receiving space **802** and the first receiving space **801** are disposed side by side.

Referring to FIG. 1, FIG. 2, FIG. 4 and FIG. 6, in assembly, the signal terminals **20** and the conductive terminals **30** are molded integrally with the insulating housing **10**. Specifically, the first fastening portions **211** and the second fastening portions **212** of the first signal terminals **21** are molded in the bottom wall of the first accommodating chamber **151**. The first contact portions **213** of the first signal terminals **21** project into the first accommodating chamber **151** through the openings **16** at the front of the bottom wall of the first accommodating chamber **151**. The first soldering portions **214** of the first signal terminals **21** project out of the bottom wall of the first accommodating chamber **151** from a front end of the bottom wall of the first accommodating chamber **151**. The third fastening portions **221** and the enforcing portions **222** of the second signal terminals **22** are molded in the bottom wall of the first accommodating chamber **151**. The second contact portions **223** of the second signal terminals **22** project into the first accommodating chamber **151** through the openings **16** at the rear of the bottom wall of the first accommodating chamber **151**. The second soldering portions **224** of the second signal terminals **22** project out of the bottom wall of the first accommodating chamber **151** from a rear end of the bottom wall of the first accommodating chamber **151**. The locating portions **31** of the conductive terminals **30** are molded in the bottom wall of the second accommodating chamber **152**. The touching portions **32** of the conductive terminals **30** project into the second accommodating chamber **152** through the window **17**. The soldering feet **33** of the conductive terminals **30** project out of the bottom wall of the second accommodating chamber **152** through a front end of the bottom wall of the second accommodating chamber **152**.

The first switch terminal **40** is disposed in the first switch terminal groove **121**. The first fastening arm **43**, the first elastic arm **44** and the first restraining arm **46** are received in the receiving groove **1211**. The first base arm **41** and the first soldering arm **42** are disposed in the notch **1212**. The insertion arm **47** is inserted into the insertion slot **1213**. The first touching arm **45** projects into the first accommodating chamber **151**. The second switch terminal **50** is disposed in the second switch terminal groove **132**. The second base arm **51** is fastened in the fastening slit **1321**. The second soldering arm **52** projects out of the insulating housing **10** through a rear of the rear wall **14**. The second fastening arm **53** is inserted into the inserting slot. The second elastic arm **54** and the second restraining arm **56** are disposed in the accommodating groove **1322**. The second touching arm **55** projects into the second accommodating chamber **152** through the connecting groove **1323**. Two opposite sides of each connecting plate **62** are clipped in the clipping slots **1312**. Middles of the connecting plates **62** of the fastening elements **60** are located in the passage **1311** with the buckling portion **1313** being buckled in the buckling hole **621**. The pressing plates **61** of the two fastening elements **60** project into the accommodating chamber **15** of the insulating housing **10** and are respectively propped up by tops of insides of the first side wall **12** and the second side wall **13**. The soldering plates **63** of the fastening elements **60** project out of the first side wall **12** and the second side wall **13** from the passages **1311** respectively. The limiting element **70** is disposed in the limiting terminal groove **122**. The fastening strips **71** are fastened in the fastening slots **1222**. The insertion strips **72** are inserted into the fastening fillisters. The protrusion **1223** resists against the resisting

6

portion **73** to make the resisting portion **73** project into the first accommodating chamber **151** of the accommodating chamber **15**.

Referring to FIGS. 1-6, in use, the micro-SIM card **91** is inserted into the first receiving space **801** of the supporting tray **80** and the micro-SD card **92** is inserted into the second receiving space **802** of the supporting tray **80** to dispose the micro-SIM card **91** and the micro-SD card **92** in the supporting tray **80** side by side. Then the supporting tray **80** together with the micro-SIM card **91** and the micro-SD card **92** is inserted in the accommodating chamber **15** of the insulating housing **10** to make the micro-SIM card **91** located in the first accommodating chamber **151** and the micro-SD card **92** located in the second accommodating chamber **152**. The base plate **81** is located on the separating block **111**. The pressing plates **61** of the fastening elements **60** press on the first clamping plates **85** and the second clamping plates **87** of the supporting tray **80** to restrain the supporting tray **80** in the accommodating chamber **15**. The resisting portion **73** of the limiting element **70** is buckled in the notch **851** of the supporting tray **80** to prevent the supporting tray **80** receding from the accommodating chamber **15** of the insulating housing **10**. A middle part of the resisting arm **885** is flat arched inward to restrict the micro-SD card **92** in the second receiving space **802**. At this moment, the supporting tray **80** together with the micro-SIM card **91** and the micro-SD card **92** is fully inserted into the accommodating chamber **15** of the insulating housing **10**. Bottoms of the first receiving space **801** and the second receiving space **802** are further opened freely to make the micro-SIM card **91** electrically contact with first contact portions **213** of the first signal terminals **21** and the second contact portions **223** of the second signal terminals **22**, and the micro-SD card **92** electrically contact with the touching portions **32** of the conductive terminals **30**. The first touching arm **45** of the first switch terminal **40** resists against the blocking tail **86** of the supporting tray **80**, and the second touching arm **55** of the second switch terminal **50** resists against the resisting arm **885** of the supporting tray **80**. The second touching arm **55** of the second switch terminal **50** is blocked between the two propping arms **884** to prevent the supporting tray **80** receding from the accommodating chamber **15** of the insulating housing **10**.

As described above, the supporting tray **80** together with the micro-SIM card **91** and the micro-SD card **92** is inserted in the accommodating chamber **15** of the insulating housing **10** to make the micro-SIM card **91** and the micro-SD card **92** insert in the card connector **100** simultaneously so as to facilitate the micro-SIM card **91** and the micro-SD card **92** for being assembled in the card connector **100**. Furthermore, the first receiving space **801** and the second receiving space **802** of the supporting tray **80** for receiving the micro-SIM card **91** and the micro-SD card **92** respectively are disposed side by side to lower a thickness of the card connector **100**.

What is claimed is:

1. A card connector adapted for receiving a micro-SIM (Subscriber Identity Module) card and a micro-SD (Secure Digital) card therein, comprising:

an insulating housing having a base board, a first side wall and a second side wall protruding upward from two opposite sides of the base board, and a rear wall connecting with rear ends of the first side wall and the second side wall, an accommodating chamber being formed among the base board, the first side wall, the second side wall and the rear wall, one side of the base board defining two rows of openings communicating with one side of the accommodating chamber, a rear of

7

the other side of the base board defining a window communicating with the other side of the accommodating chamber;

a plurality of signal terminals disposed in the insulating housing with contact portions thereof projecting into the one side of the accommodating chamber through the openings respectively;

a plurality of conductive terminals disposed in the insulating housing with touching portions thereof projecting into the other side of the accommodating chamber through the window; and

a supporting tray defining a first receiving space and a second receiving space with front ends thereof being opened freely for receiving the micro-SIM card and the micro-SD card therein, respectively, the supporting tray together with the micro-SIM card and the micro-SD card being inserted into the accommodating chamber of the insulating housing, bottoms of the first receiving space and the second receiving space being further opened freely to make the micro-SIM card electrically contact with the contact portions of the signal terminals and the micro-SD card electrically contact with the touching portions of the conductive terminals;

wherein a separating block protrudes upward from a substantial middle of the base board and extends longitudinally to divide the accommodating chamber into a first accommodating chamber with the contact portions projecting therein and a second accommodating chamber with the touching portions projecting therein, the micro-SIM card is located in the first accommodating chamber, the micro-SD card is located in the second accommodating chamber, the supporting tray has a base plate of which two opposite sides bend upward to form two lateral plates, two tops of the two lateral plates extend oppositely to form a first top plate and a second top plate, a plurality of first clamping plates of substantial U-shape from a front view is connected with a free side edge of the first top plate with the mouths thereof facing the corresponding lateral plate at a distance, a free corner at the rear of the first top plate is bent downward, and then bent inward to form a blocking tail, the first receiving space is formed among the first top plate, the corresponding lateral plate, the first clamping plates and the blocking tail, a plurality of second clamping plates of substantial U-shape from the front view is connected with a free side edge of the second top plate with the mouths thereof facing the corresponding lateral plate at a distance, a rear of the free side of the second top plate is cut off to define a gap which has a straight sidewall substantially extending longitudinally, and a tilted sidewall connecting between a front end of the straight sidewall and the free side edge of the second top plate, the

8

tilted sidewall of the gap extends downward and then bends inward to form a blocking plate, two portions of the straight sidewall protrude outward and then bend downward to form two propping arms of which two free ends are connected by a resisting arm therebetween, the second receiving space is formed among the second top plate, the corresponding lateral plate, the second clamping plates, the blocking plate, the propping arms and the resisting arm, and a middle part of the resisting arm is flat arched inward to restrict the micro-SD card in the second receiving space.

2. The card connector as claimed in claim 1, wherein a notch is formed between two of the first clamping plates and located at the rear of the first top plate, and the card connector further includes a limiting element disposed in the first side wall with a resisting portion thereof projecting into the first accommodating chamber to be buckled in the notch.

3. The card connector as claimed in claim 1, further comprising two fastening elements respectively disposed in the first side wall and the second side wall, each fastening element having a pressing plate at a top thereof and a soldering plate at a bottom thereof, the pressing plates projecting into the accommodating chamber to press on the first clamping plates and the second clamping plates, and the soldering plates projecting out of the first side wall and the second side wall, respectively.

4. The card connector as claimed in claim 1, further comprising a first switch terminal having a first base arm, one end of the first base arm being inclined rearward and sideward to form a first fastening arm, a free end of the first fastening arm being bent sideward and then slantwise extending forward to form a first elastic arm away from the first base arm, a free end of the first elastic arm being arched outward to form a first touching arm, a corner between the first side wall and the rear wall defining a first switch terminal groove, and the first switch terminal being disposed in the first switch terminal groove with the first touching arm projecting into the first accommodating chamber to resist against the blocking tail of the supporting tray.

5. The card connector as claimed in claim 1, further comprising a second switch terminal having a second base arm, one end of the second base arm bending forward to form a second elastic arm, a free end of the second elastic arm being arched sideward to form a second touching arm located in front of the second base arm, the insulating housing defining a second switch terminal groove distributed in the second side wall and the rear wall, and the second switch terminal being disposed in the second switch terminal groove with the second touching arm projecting into the second accommodating chamber to resist against the resisting arm of the supporting tray.

* * * * *