



US008552786B1

(12) **United States Patent**
Sheng et al.

(10) **Patent No.:** **US 8,552,786 B1**
(45) **Date of Patent:** **Oct. 8, 2013**

(54) **SYSTEM AND METHOD OF ADJUSTING CURRENT DRAWN BY AN INTEGRATED CIRCUIT BASED ON FREQUENCIES OF CLOCK SIGNALS**

(58) **Field of Classification Search**
USPC 327/291, 298-299, 393, 398
See application file for complete search history.

(71) Applicant: **Marvell International Ltd.**, Hamilton (BM)

(56) **References Cited**

U.S. PATENT DOCUMENTS

(72) Inventors: **Hongying Sheng**, San Jose, CA (US); **Chen Liu**, Newark, CA (US); **Wei Cao**, San Jose, CA (US)

6,396,324 B1 * 5/2002 Hsu et al. 327/298

* cited by examiner

(73) Assignee: **Marvell International Ltd.**, Hamilton (BM)

Primary Examiner — An Luu

(*) Notice: Subject to any disclaimer, the term of this patent is extended or adjusted under 35 U.S.C. 154(b) by 0 days.

(57) **ABSTRACT**

A system including a first clock module, a second clock module and an adjustment module. The first clock module is configured to generate a first clock signal having a first frequency. The second clock module is configured to, based on the first clock signal, generate a second clock signal for an integrated circuit. An amount of current drawn by the integrated circuit is based on a second frequency of the second clock signal. An adjustment module is configured to receive an enable signal indicating whether the integrated circuit is being powered ON. In response to the enable signal indicating the integrated circuit is being powered ON, the adjustment module (i) determines a predetermined frequency, and (ii) generate a control signal based on the first clock signal. The control signal adjusts the second frequency of the second clock signal to be between the predetermined frequency and the first frequency.

(21) Appl. No.: **13/741,705**

(22) Filed: **Jan. 15, 2013**

Related U.S. Application Data

(63) Continuation of application No. 13/090,600, filed on Apr. 20, 2011, now Pat. No. 8,354,869.

(60) Provisional application No. 61/334,487, filed on May 13, 2010.

(51) **Int. Cl.**
G06F 1/04 (2006.01)

(52) **U.S. Cl.**
USPC 327/291; 327/298

20 Claims, 7 Drawing Sheets

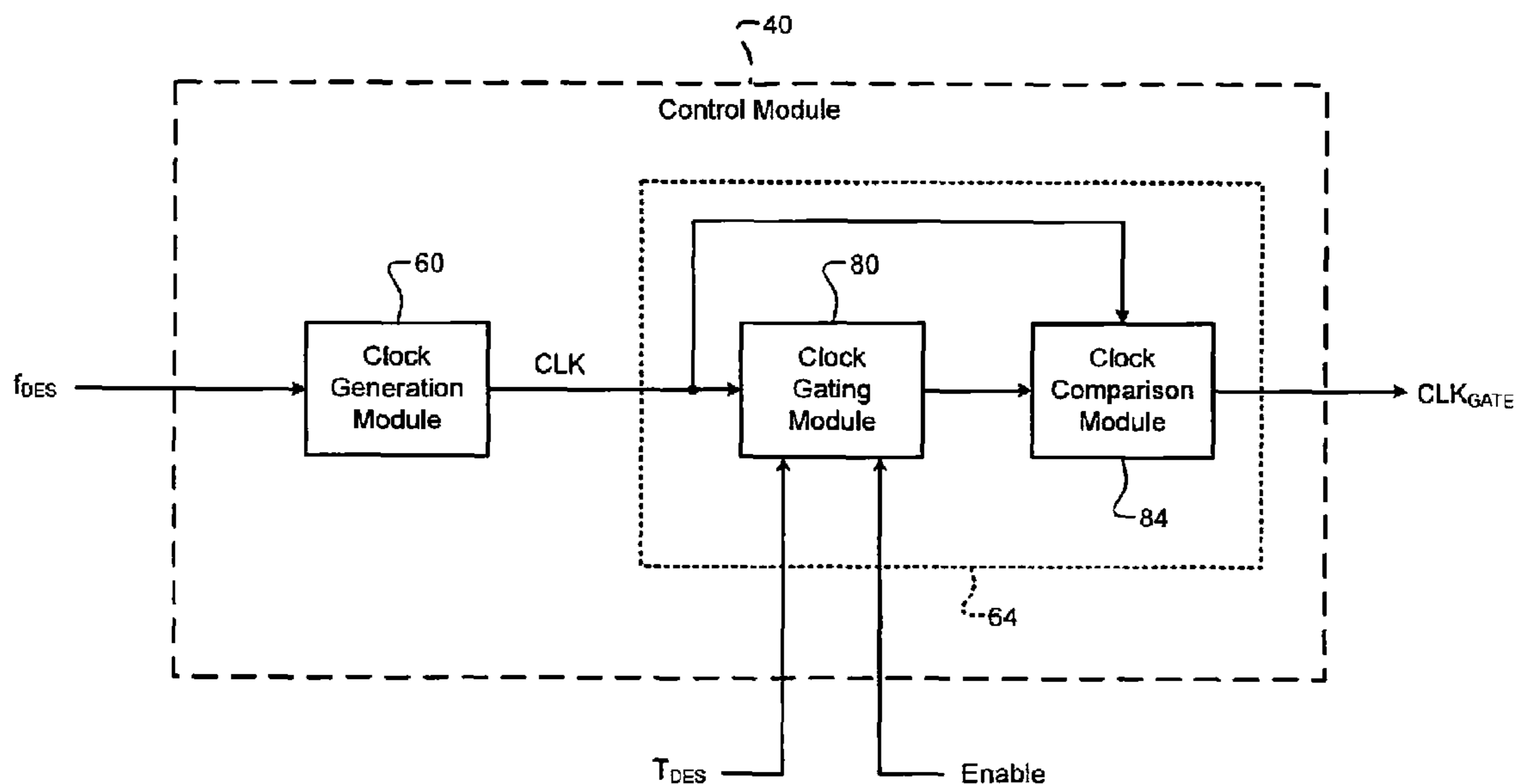

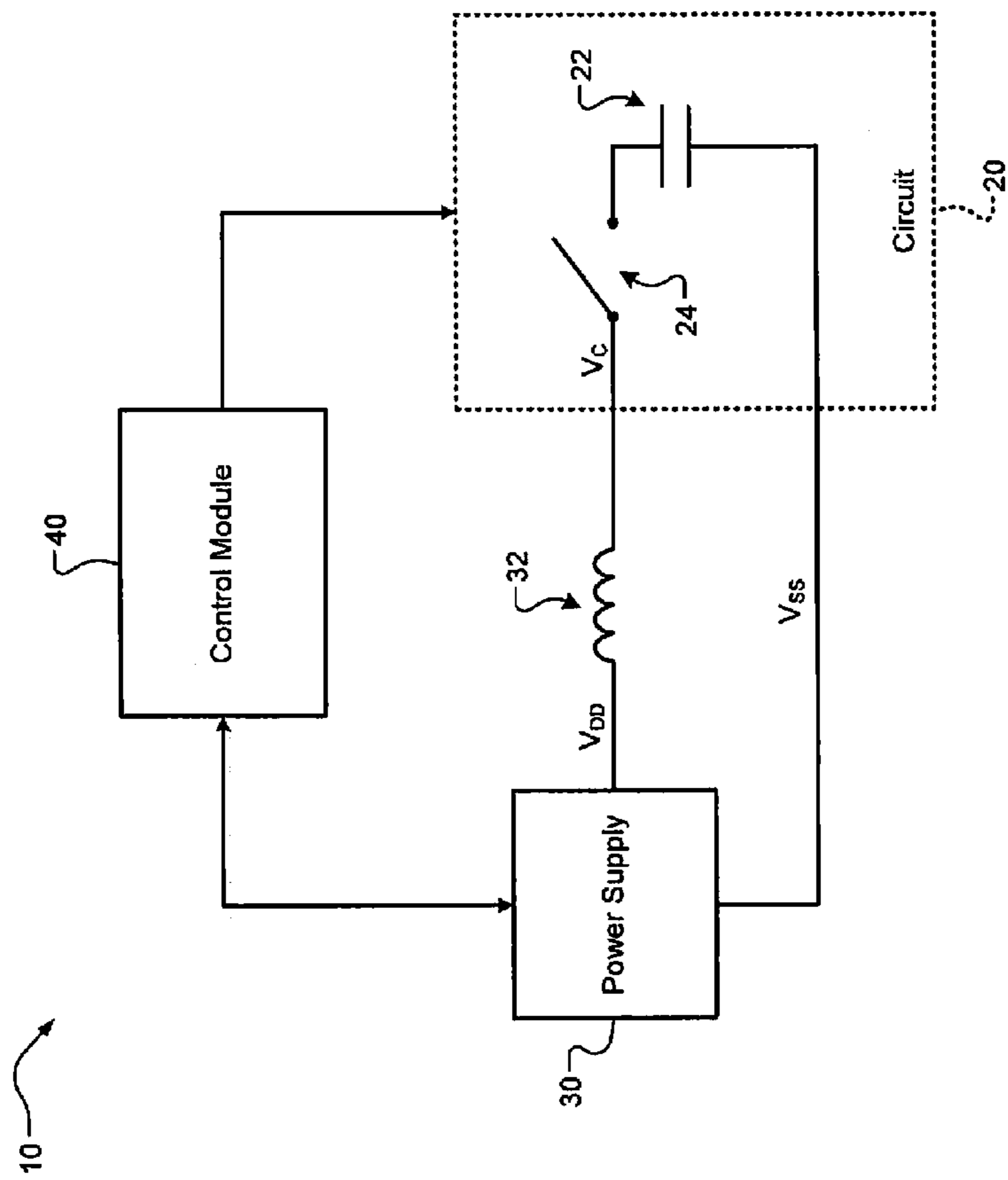

FIG. 1

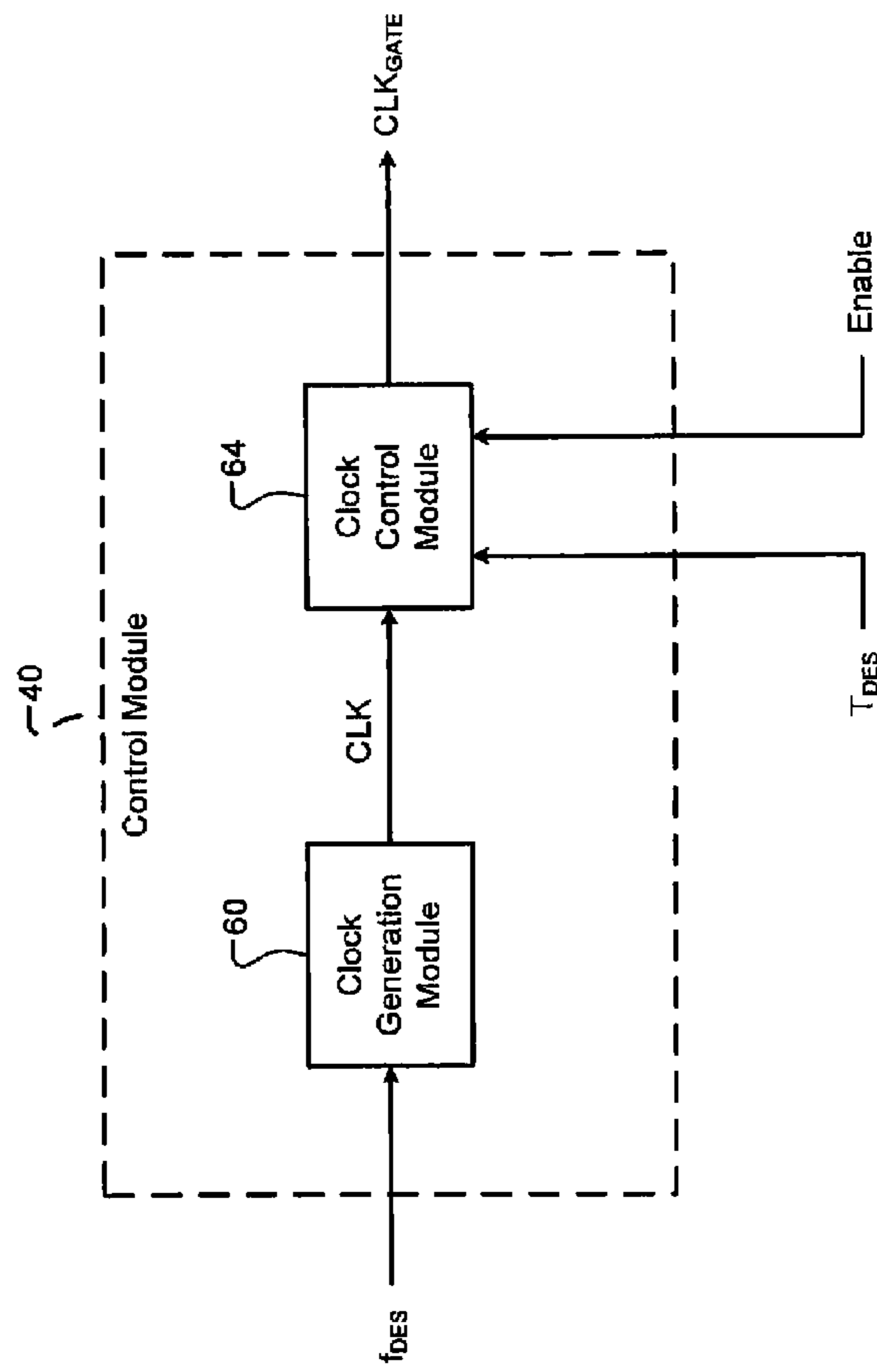

FIG. 2A

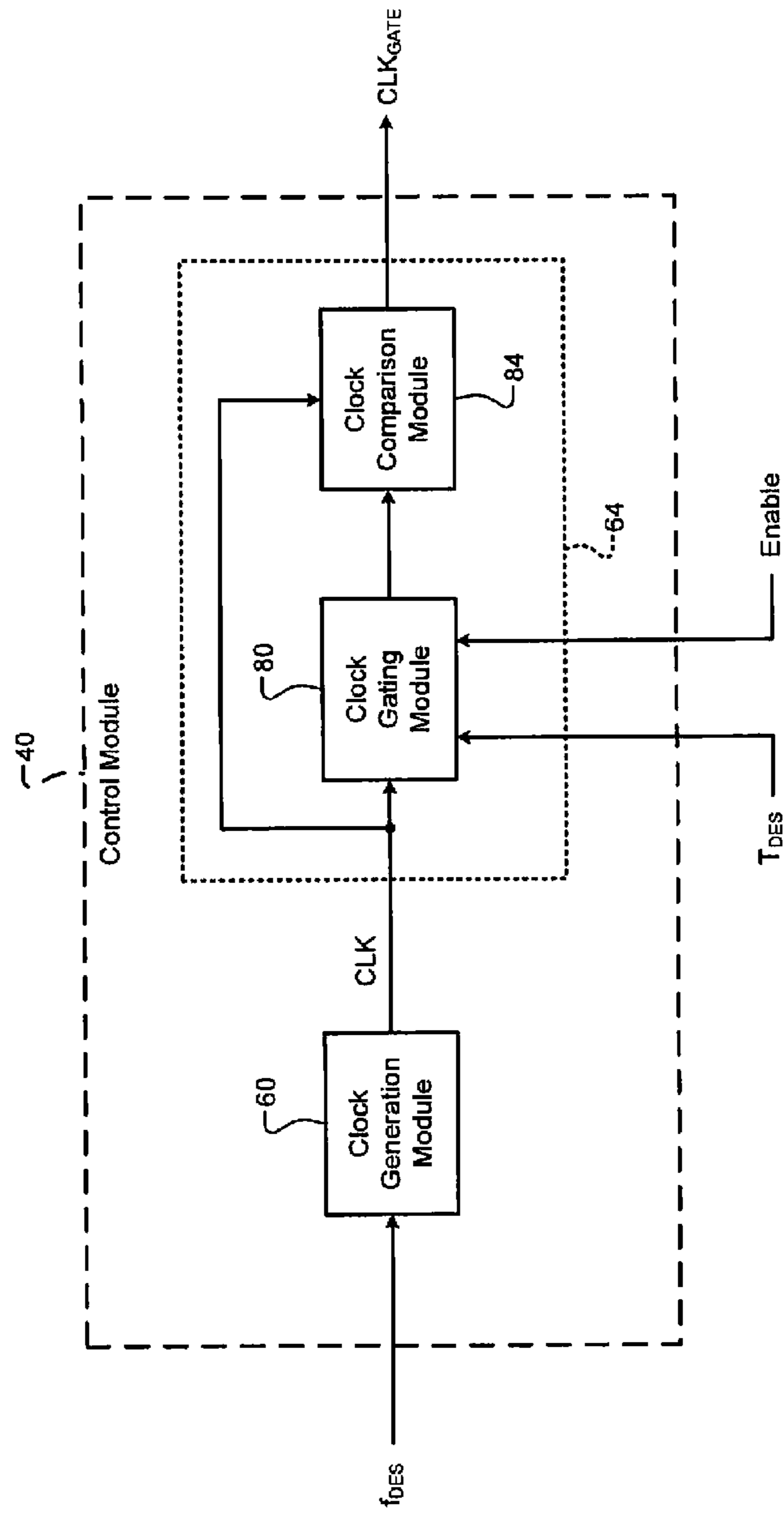
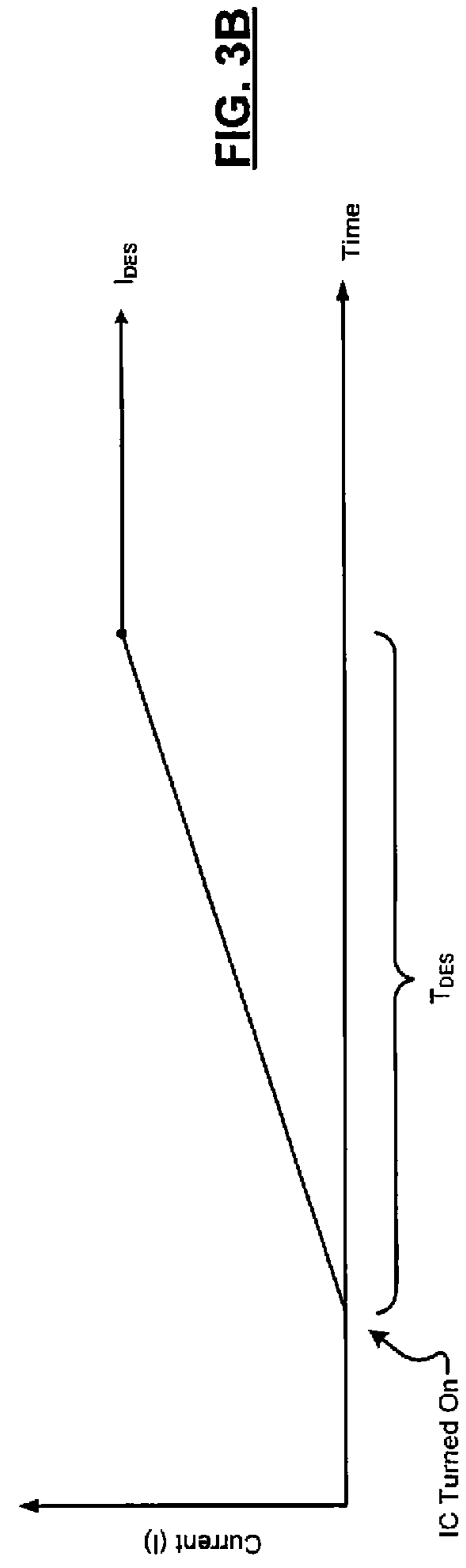
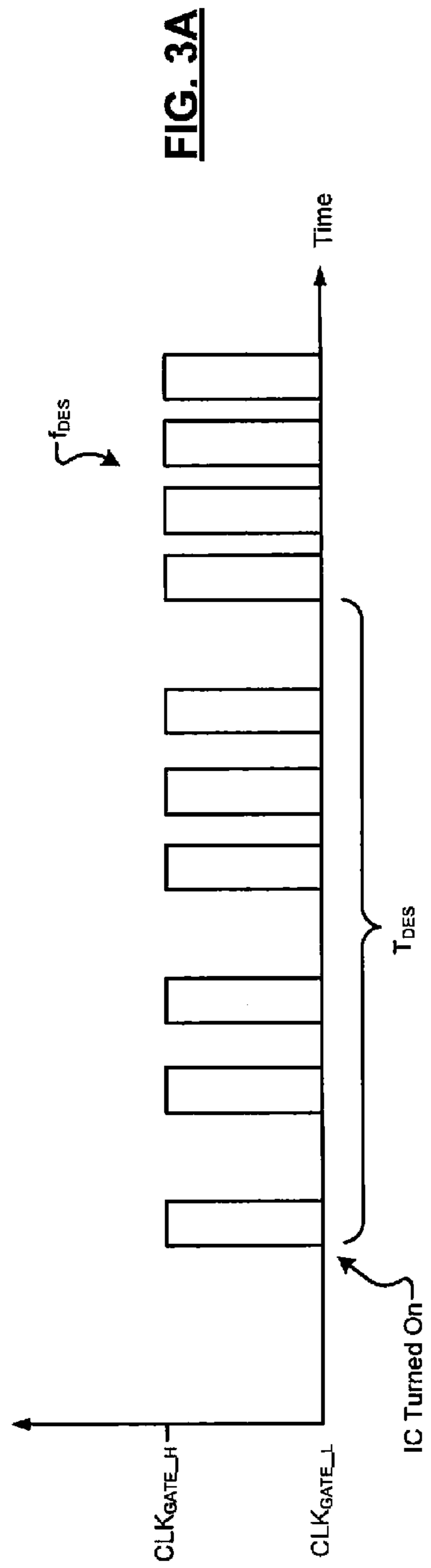

FIG. 2B



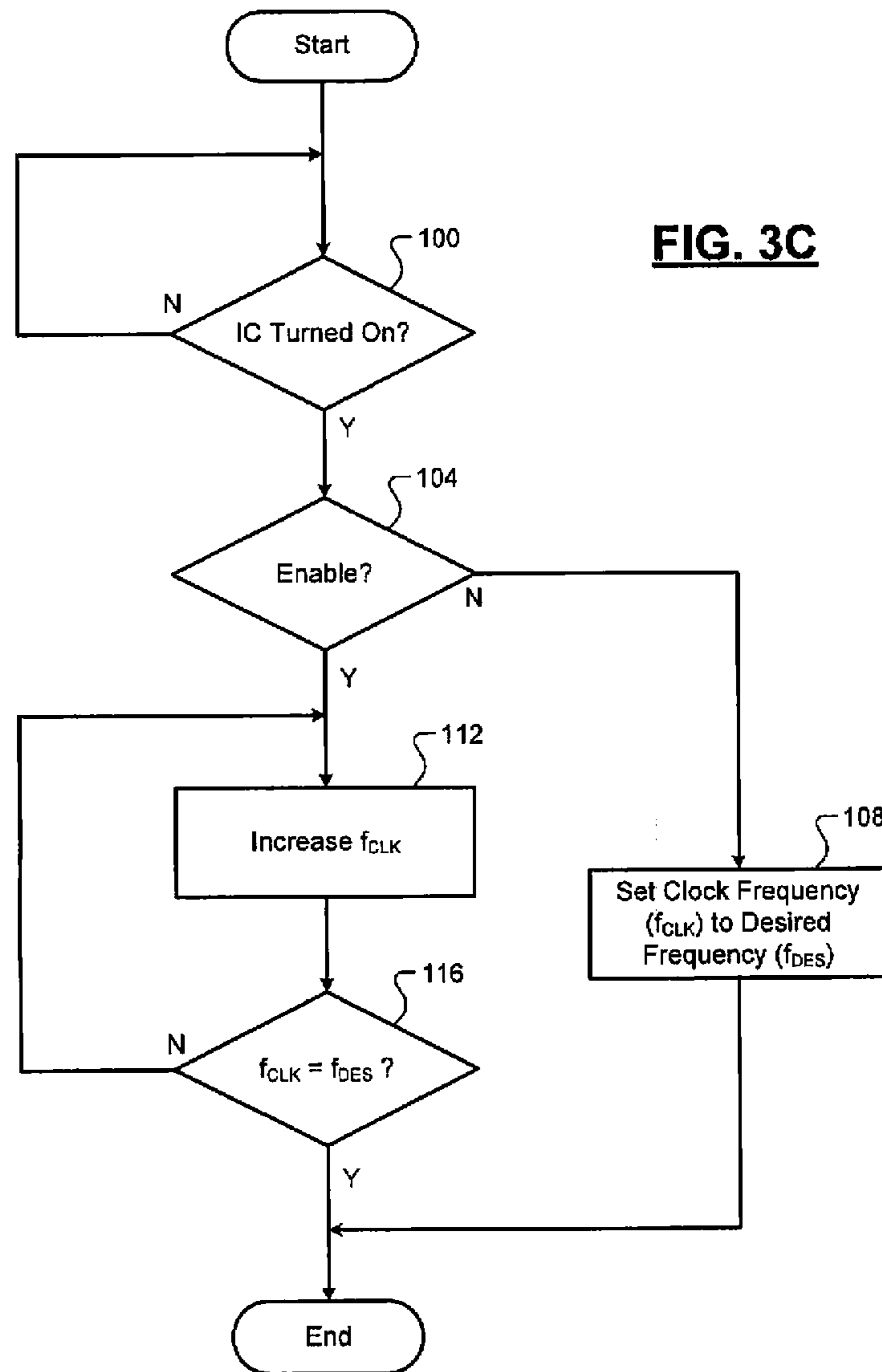

FIG. 4A

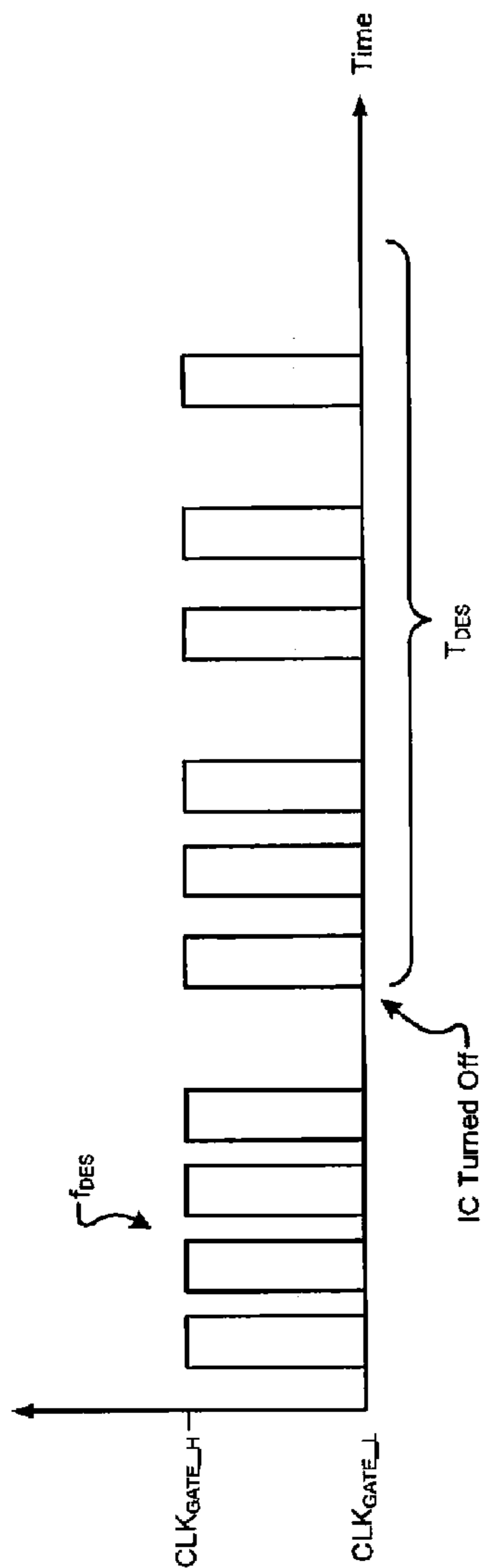
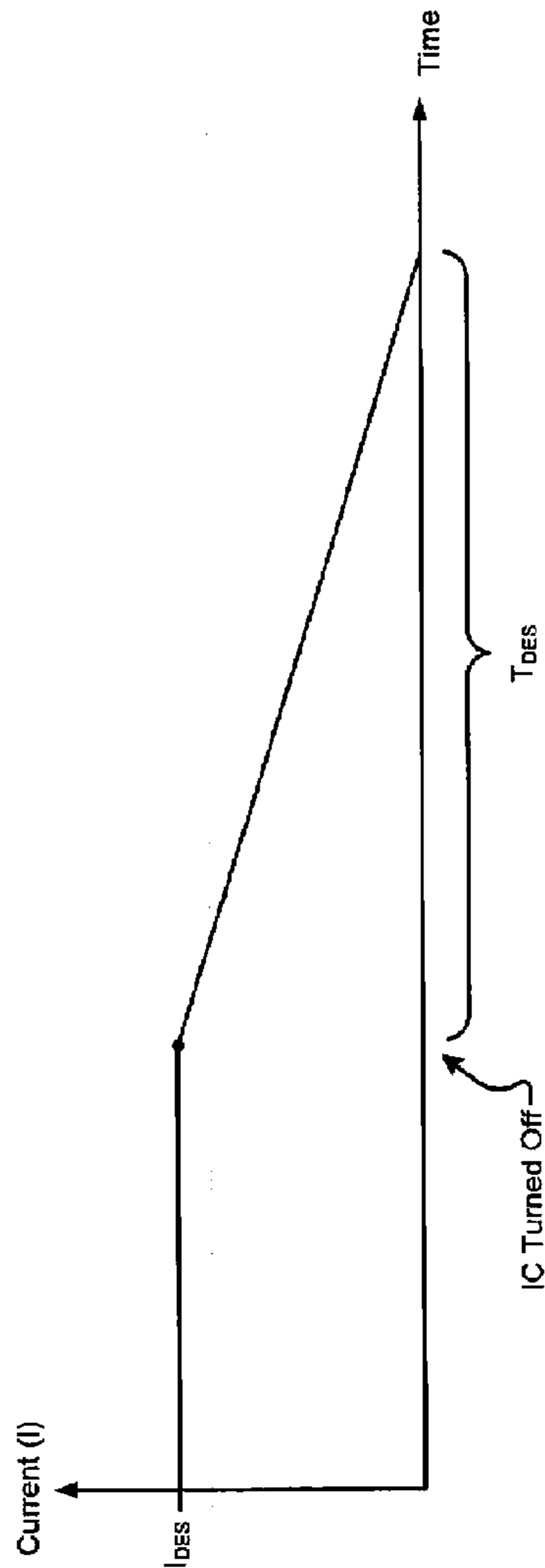
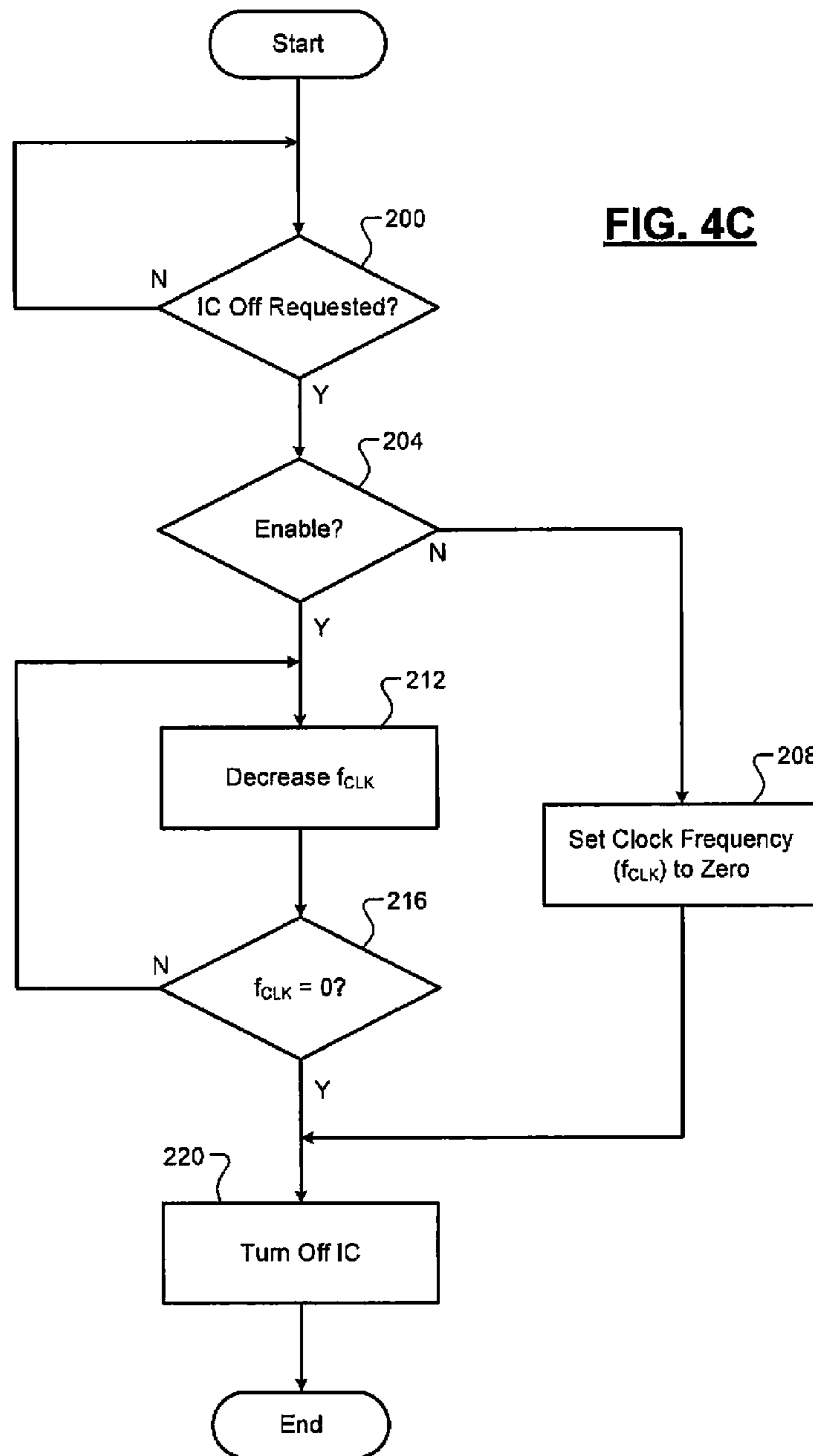

FIG. 4B





1

**SYSTEM AND METHOD OF ADJUSTING
CURRENT DRAWN BY AN INTEGRATED
CIRCUIT BASED ON FREQUENCIES OF
CLOCK SIGNALS**

CROSS-REFERENCE TO RELATED
APPLICATIONS

This application is a continuation of U.S. patent application Ser. No. 13/090,600, filed Apr. 20, 2011 (now U.S. Pat. No. 8,354,869) which claims the benefit of U.S. Provisional Application No. 61/334,487, filed on May 13, 2010. The disclosures of the above applications are incorporated herein by reference in their entirety.

FIELD

The present disclosure relates to power supplies and more particularly to systems and methods for controlling power supply current using clock gating.

BACKGROUND

The background description provided herein is for the purpose of generally presenting the context of the disclosure. Work of the presently named inventors, to the extent the work is described in this background section, as well as aspects of the description that may not otherwise qualify as prior art at the time of filing, are neither expressly nor impliedly admitted as prior art against the present disclosure.

A power supply outputs a voltage that may be used to power one or more components. For example, the voltage may power one or more components of an integrated circuit (IC). Specifically, the IC may draw current from the power supply when the IC is on. For example, the IC may include a switch that selectively connects the power supply to the IC. A magnitude of the current draw is related to the overall capacitance of the IC. A large IC, therefore, may draw a large amount of current from the power supply. The power supply, however, may not be able to supply the requested current. The excessive current request may decrease performance of the IC due to current lag and/or may damage the power supply.

SUMMARY

A system is provided and includes a first clock module, a second clock module and an adjustment module. The first clock module is configured to generate a first clock signal having a first frequency. The second clock module is configured to, based on the first clock signal, generate a second clock signal for an integrated circuit. An amount of current drawn by the integrated circuit is based on a second frequency of the second clock signal. An adjustment module is configured to receive an enable signal indicating whether the integrated circuit is being powered ON. In response to the enable signal indicating the integrated circuit is being powered ON, the adjustment module (i) determines a predetermined frequency, and (ii) generate a control signal based on the first clock signal. The control signal adjusts the second frequency of the second clock signal to be between the predetermined frequency and the first frequency.

In other features, a method is provided and includes generating a first clock signal having a first frequency. Based on the first clock signal, a second clock signal is generated for an integrated circuit. An amount of current drawn by the integrated circuit is based on a second frequency of the second clock signal. An enable signal indicating whether the inte-

2

grated circuit is being powered ON is received. Responsive to the enable signal indicating the integrated circuit is being powered ON, (i) a predetermined frequency is determined, and (ii) a control signal is generated based on the first clock signal. The control signal adjusts the second frequency of the second clock signal to be between the predetermined frequency and the first frequency.

In other features, a control system includes a clock gating module and a clock comparison module. The clock gating module is configured to generate a gating signal based on an enable signal, a given period, and a base clock signal having a given frequency. The clock comparison module is configured to generate a gated clock signal based on the base clock signal and the gating signal.

In other features, the clock gating module is configured to generate the gating signal to increase a frequency of the gated clock signal from zero to the given frequency during the given period. In other features, the frequency of the gated clock signal increases linearly or exponentially during the given period.

In other features, the clock gating module is configured to generate the gating signal to decrease the frequency of the gated clock signal from the given frequency to zero during the given period. In other features, the frequency of the gated clock signal decreases linearly or exponentially during the given period.

In other features, the clock comparison module is configured to generate the gated clock signal based on a comparison of the base clock signal and the gating signal. In other features, the comparison includes performing a logical AND operation of the base clock signal and the gating signal.

In other features, the gating module is configured to generate the gating signal based on the given period and the given frequency when the enable signal is in a first state. In other features, the gating module is configured to generate a gating signal having a constant first state when the enable signal is in a second state.

In other features, the clock comparison module is configured to generate the gated clock signal based on the base clock signal and the gating signal when the enable signal is in a first state, and is configured to generate the gated clock signal based on the base clock signal when the enable signal is in a second state.

A method includes generating a gating signal based on an enable signal, a given period, and a base clock signal having a given frequency, and generating a gated clock signal based on the base clock signal and the gating signal.

In other features, the method includes generating the gating signal to increase a frequency of the gated clock signal from zero to the given frequency during the given period. In other features, the frequency of the gated clock signal increases linearly or exponentially during the given period.

In other features, the method includes generating the gating signal to decrease the frequency of the gated clock signal from the given frequency to zero during the given period. In other features, the frequency of the gated clock signal decreases linearly or exponentially during the given period.

In other features, the method includes generating the gated clock signal based on a comparison of the base clock signal and the gating signal. In other features, the comparison includes performing a logical AND operation of the base clock signal and the gating signal.

In other features, the method includes generating the gating signal based on the given period and the given frequency when the enable signal is in a first state. In other features, the method includes generating a gating signal having a constant first state when the enable signal is in a second state.

In other features, the method includes generating the gated clock signal based on the base clock signal and the gating signal when the enable signal is in a first state, and generating the gated clock signal based on the base clock signal when the enable signal is in a second state.

Further areas of applicability of the present disclosure will become apparent from the detailed description, the claims and the drawings. The detailed description and specific examples are intended for purposes of illustration only and are not intended to limit the scope of the disclosure.

BRIEF DESCRIPTION OF DRAWINGS

The present disclosure will become more fully understood from the detailed description and the accompanying drawings, wherein:

FIG. 1 is a functional block diagram of an example of a system according to one implementation of the present disclosure;

FIG. 2A is a functional block diagram of an example of a control module according to one implementation of the present disclosure;

FIG. 2B is a functional block diagram of an example of a control module according to another implementation of the present disclosure;

FIGS. 3A-3B are examples of timing diagrams illustrating power supply current control using clock gating according to one implementation of the present disclosure;

FIG. 3C is a flow diagram illustrating an example of a method for controlling power supply current using clock gating according to one implementation of the present disclosure;

FIGS. 4A-4B are examples of timing diagrams illustrating power supply current control using clock gating according to another implementation of the present disclosure; and

FIG. 4C is a flow diagram illustrating an example of a method for controlling power supply current using clock gating according to another implementation of the present disclosure.

DESCRIPTION

The following description is merely illustrative in nature and is in no way intended to limit the disclosure, its application, or uses. For purposes of clarity, the same reference numbers will be used in the drawings to identify similar elements. As used herein, the phrase at least one of A, B, and C should be construed to mean a logical (A or B or C), using a non-exclusive logical OR. It should be understood that steps within a method may be executed in different order without altering the principles of the present disclosure.

As used herein, the term module may refer to, be part of, or include an Application Specific Integrated Circuit (ASIC); an electronic circuit; a combinational logic circuit; a field programmable gate array (FPGA); a processor (shared, dedicated, or group) that executes code; other suitable components that provide the described functionality; or a combination of some or all of the above, such as in a system-on-chip. The term module may include memory (shared, dedicated, or group) that stores code executed by the processor.

The term code, as used above, may include software, firmware, and/or microcode, and may refer to programs, routines, functions, classes, and/or objects. The term shared, as used above, means that some or all code from multiple modules may be executed using a single (shared) processor. In addition, some or all code from multiple modules may be stored

by a single (shared) memory. The term group, as used above, means that some or all code from a single module may be executed using a group of processors. In addition, some or all code from a single module may be stored using a group of memories.

The apparatuses and methods described herein may be implemented by one or more computer programs executed by one or more processors. The computer programs include processor-executable instructions that are stored on a non-transitory tangible computer readable medium. The computer programs may also include stored data. Non-limiting examples of the non-transitory tangible computer readable medium are nonvolatile memory, magnetic storage, and optical storage.

Connections between an integrated circuit (IC) and a power supply may have a built-in inductance. For example, leads on a printed circuit board (PCB) have a built-in inductance. The inductance may decrease a rate of change of current flowing from the power supply to the IC. Specifically, the IC may draw a large amount of current when switched on, but the rapid change in current may be slowed by the inductance. Therefore, a voltage at the IC may decrease for a period before reaching steady-state. The power supply may be modified to generate more current. However, producing application-dependent power supplies may be costly.

The magnitude of the current drawn by the IC is a function of the overall capacitance of the IC, the overall inductance of the IC, and a frequency of a clock that controls switching within the IC. The current request, therefore, may be controlled by adjusting the clock frequency. After switching the IC on, the clock frequency may be increased from zero to a desired clock frequency during a desired period. Clock gating is one technique used to save power in an IC. Clock gating includes circuits that enable or disable the clock. For example, the clock may be enabled when the IC is on and may be disabled when the IC is off. Clock gating, therefore, may also be used to control the clock frequency.

Accordingly, systems and methods are presented for controlling current output by a power supply using clock gating. The systems and methods may generate a gating signal when enabled based on a desired period and a base clock signal having a desired frequency. The desired period may be input by a user. The desired frequency may be input by a user or may be predetermined and stored in memory. The systems and methods may then generate a gated clock signal based on the desired period and the desired frequency. For example, the systems or methods may be implemented in a clocking circuit that resides on a PCB, the PCB further including a power supply and a clocked circuit. Specifically, for example only, the systems or methods may be implemented in soft output Viterbi algorithm (SOVA) decoder systems.

When the IC is turned on, the systems and methods may generate the gating signal to increase the frequency of the gated clock signal from zero to the desired frequency during the desired period. Additionally or alternatively, when the IC is to be turned off, the systems and methods may generate the gating signal to decrease the frequency of the gated clock signal from the desired frequency to zero during the desired period, and then the IC may be turned off. For example, the systems and methods may generate the gated clock signal using a logical AND of the base clock signal and the gating signal. In some implementations, the change in the frequency of the gated clock signal may be linear. In other implementations, the change in the frequency of the gated clock signal may be non-linear. For example, the non-linear change in the gated clock frequency may be exponential.

5

Referring now to FIG. 1, an example of a system **10** is shown. The system **10** includes a circuit **20** powered by a power supply **30**. For example, the circuit **20** may be an IC and hereinafter may be referred to as the IC **20**. The IC **20** may be represented as a capacitor **22** connected in series with a switch **24**. The capacitor **22** has a capacitance (C_{IC}) representing a total capacitance of the IC **20**. The total capacitance C_{IC} increases as a size of the IC **20** increases. Actuating the switch **24** turns the IC **20** on or off. Specifically, the switch **24** controls a connection between the power supply **30** and the IC **20**. For example, the switch **24** may include one or more transistors.

The power supply **30** supplies current to the IC **20** based on a current request by the IC **20**. The connection between the power supply **30** and the IC **20** has a built-in inductance (I_{BI}) represented by an inductor **32**. The built-in inductance I_{BI} may decrease the rate of change in current supplied by the power supply **30** to the IC **20**. For example, a rapid change in current requested by the IC **20** may cause a voltage (V_C) at the IC **20** to drop from a voltage (V_{DD}) output by the power supply **30**. The power supply **30** may also supply a steady-state voltage (V_{SS}) to the IC **20**. For example, the steady-state voltage V_{SS} may be zero volts (V).

A control module **40** controls the IC **20** and/or the power supply **30**. Specifically, the control module **40** may control the switch **24** to turn the IC **20** on. The control module **40** may also enable/disable the power supply **30**. In addition, the control module **40** controls switching in the IC **20**. The control module **40** may generate a clock signal and may also perform clock gating. Specifically, the control module **40** may generate a gated clock signal that controls switching in the IC **20**. Therefore, the control module **40** may also implement the system or method of the present disclosure.

Referring now to FIG. 2A, a first example of the control module **40** is shown. The control module includes a clock generation module **60** and a clock control module **64**. The clock generation module **60** receives a desired frequency (f_{DES}) for the clock signal (CLK). For example, the clock generation module **60** may include a pulse width modulator (PWM) that generates a base clock signal having the desired frequency f_{DES} . A value of the desired frequency f_{DES} may be input by a user. The value of the desired frequency f_{DES} , however, may also be predetermined and stored in memory. For example only, the value of the desired frequency may be 2 gigahertz (GHz).

The clock control module **64** receives the clock signal CLK. The clock control module **64** may also receive the desired frequency f_{DES} or alternatively may determine the desired frequency f_{DES} from the clock signal CLK. The clock control module **64** also receives a desired period T_{DES} and an enable signal. The desired period T_{DES} represents a period during which the clock signal is gate-controlled. For example, a value of the desired period T_{DES} may be input by the user. In some implementations, the value of the desired period T_{DES} may also be predetermined and stored in memory.

The clock control module **64** generates a gated clock signal (CLK_{GATE}) based on the clock signal CLK (i.e., the desired frequency f_{DES}), the desired period T_{DES} , and the enable signal. Specifically, a frequency (f_{CLK}) of the gated clock signal CLK_{GATE} may be less than or equal to the desired frequency f_{DES} . The enable signal enables or disables the power supply current control feature of the present disclosure. The enable signal may be input by the user. In other words, when disabled the clock control module **64** may not control the power supply current (i.e., CLK_{GATE}=CLK). Rather, when disabled the power supply **30** may output a fixed current based on the clock CLK.

6

Specifically, the frequency f_{CLK} of the gated clock signal CLK_{GATE} generated by the clock control module **64** may either (i) increase from zero to the desired frequency f_{DES} during the desired period T_{DES} or (ii) decrease from the desired frequency f_{DES} to zero during the desired period T_{DES} . The change in the frequency f_{CLK} may be either linear or non-linear. For example, non-linear change of the frequency f_{CLK} may be exponential.

For example only, the frequency f_{CLK} may be based on a quotient where the desired frequency f_{DES} is periodically divided by a decreasing factor throughout the desired period. This periodic division by a decreasing factor may also be referred to as an exponential increase. For example, the decreasing factors may be 2^8 , 2^7 , 2^6 , . . . , 2^1 , and 2^0 . Therefore, for example only, for a desired frequency f_{DES} of 2 GHz, the frequency f_{CLK} of the gated clock signal CLK_{GATE} may be as follows during the desired period T_{DES} :

$$0, 7.8125, 15.625, 31.25, 62.5, 125, 250, 500, 1000, \frac{2000}{2000} \quad (1),$$

where each number in the sequence is in megahertz (MHz).

Referring now to FIG. 2B, a second example of the control module **40** is shown. The control module **40** includes the clock generation module **60**, a clock gating module **80**, and a clock comparison module **84**. The clock gating module **80** and the clock comparison module **84** may represent sub-modules of the clock control module **64** (see above and FIG. 2A).

The clock gating module **80** receives the base clock signal CLK having the desired frequency f_{DES} from the clock generation module **60**. The clock gating module **80** may also receive the desired frequency f_{DES} or determine the desired frequency f_{DES} from the base clock signal CLK. The clock gating module **80** also receives the desired period T_{DES} and the enable signal. As previously described, for example, the desired period T_{DES} and the enable signal may be input by the user.

The clock gating module **80** generates a gating signal based on the enable signal, the desired period T_{DES} , and the base clock signal CLK having the desired frequency f_{DES} . Specifically, when the enable signal is a first state (i.e., enabled) the clock gating module **80** may generate the gating signal to increase the frequency f_{CLK} of the gated clock signal CLK_{GATE} from zero to the desired frequency f_{CLK} during the desired period T_{DES} . Alternatively, when the enable signal is the first state, the clock gating module may generate the gating signal to decrease the frequency f_{CLK} of the gated clock signal CLK_{GATE} from the desired frequency f_{DES} to zero during the desired period. When the enable signal is a second state (i.e., disabled), the clock gating module **80** may generate the gating signal having a constant first state. Rather, the gating signal having a constant first state may not adjust the frequency f_{CLK} of the gated clock signal CLK_{GATE}.

The clock comparison module **84** receives the gating signal and the base clock signal CLK. The clock comparison module **84** generates the gated clock signal CLK_{GATE} based on the gating signal and the base clock signal CLK. For example, the clock comparison module **84** may perform a logical AND of the gating signal and the base clock signal CLK. Therefore, for example only, when the enable signal is the second state (i.e., disabled) the clock comparison module **84** may generate a gated clock signal CLK_{GATE} equal to the base clock signal CLK. In other words, when disabled the frequency f_{CLK} of the gated clock signal CLK_{GATE} may be set to the desired frequency f_{DES} when the IC **20** is turned on or may be set to zero when the IC **20** is turned off.

Referring now to FIG. 3A-3B, examples of timing diagrams illustrate an increase of the frequency f_{CLK} of the gated clock signal CLK_{GATE} and a corresponding increase in power supply current. FIG. 3A illustrates the increase of the frequency f_{CLK} of the gated clock signal CLK_{GATE} which alternates between a first state (CLK_{GATE_L}) and a second state (CLK_{GATE_H}). Specifically, a linear increase of the frequency f_{CLK} during the desired period T_{DES} is shown. A non-linear increase of the frequency f_{CLK} , however, may also be performed. FIG. 3B, on the other hand, illustrates the change in power supply current (I) in response to the change in frequency f_{CLK} of the gated clock signal CLK_{GATE} . After turning on the IC 20, the frequency f_{CLK} of the gated clock signal CLK_{GATE} is increased from zero to the desired frequency f_{DES} . Accordingly, the current (I) flowing from the power supply 30 to the IC 20 increases from zero to a desired current (I_{DES}).

Referring now to FIG. 3C, an example of a first method for controlling power supply current using clock gating begins at 100. At 100, the control module 40 determines whether IC 20 has turned on. If true, control may proceed to 104. If false, control may return to 100. At 104, the control module 40 determines whether the power supply current control feature is enabled (i.e., enable signal is active). If true, control may proceed to 112. If false, control may proceed to 108. At 108, the control module 40 may set the frequency f_{CLK} of the gated clock signal CLK_{GATE} to the desired clock frequency f_{DES} . Control may then end.

At 112, the control module 40 may increase the frequency f_{CLK} of the gated clock signal CLK_{GATE} . Specifically, the control module 40 may increase the frequency f_{CLK} towards the desired clock frequency f_{DES} . For example, the control module 40 may increase the frequency f_{CLK} by a predetermined amount during each of predetermined intervals of the desired period T_{DES} . At 116, the control module 40 determines whether the frequency f_{CLK} equals the desired clock frequency f_{DES} . If true, control may end. If false, control may return to 112.

Referring now to FIG. 4A-4B, example timing diagrams illustrate a decrease of the frequency f_{CLK} of the gated clock signal CLK_{GATE} and a corresponding decrease in power supply current. FIG. 4A illustrates the decrease of the frequency f_{CLK} of the gated clock signal CLK_{GATE} which alternates between a first state (CLK_{GATE_L}) and a second state (CLK_{GATE_H}). Specifically, a linear decrease of the frequency f_{CLK} during the desired period T_{DES} is shown. A non-linear decrease of the frequency f_{CLK} , however, may also be performed. FIG. 4B, on the other hand, illustrates the change in power supply current (I) in response to the change in frequency f_{CLK} of the gated clock signal CLK_{GATE} . Specifically, prior to turning off the IC 20 the frequency f_{CLK} of the gated clock signal CLK_{GATE} is decreased from the desired frequency f_{DES} to zero. Accordingly, the current (I) flowing from the power supply 30 to the IC 20 decreases from a desired current (I_{DES}) to zero. The IC 20 may then be turned off.

Referring now to FIG. 4C, an example of a second method for controlling power supply current using clock gating begins at 200. At 200, the control module 40 determines whether turning off the IC 20 has been requested. If true, control may proceed to 204. If false, control may return to 200. At 204, the control module 40 determines whether the power supply current control feature is enabled (i.e., enable signal is active). If true, control may proceed to 212. If false, control may proceed to 208. At 208, the control module 40 may set the frequency f_{CLK} of the gated clock signal CLK_{GATE} to zero. Control may then end.

At 212, the control module 40 may decrease the frequency f_{CLK} of the gated clock signal CLK_{GATE} . Specifically, the control module 40 may decrease the frequency f_{CLK} to a frequency less than the desired clock frequency f_{DES} . For example, the control module 40 may decrease the frequency f_{CLK} by a predetermined amount during each of predetermined intervals of the desired period T_{DES} . At 216, the control module 40 determines whether the frequency f_{CLK} equals zero. If true, control may proceed to 220. If false, control may return to 212. At 220, the control module 40 may turn off the IC. Control may then end.

The broad teachings of the disclosure can be implemented in a variety of forms. Therefore, while this disclosure includes particular examples, the true scope of the disclosure should not be so limited since other modifications will become apparent upon a study of the drawings, the specification, and the following claims.

What is claimed is:

1. A system comprising:

- a first clock module configured to generate a first clock signal having a first frequency;
- a second clock module configured to, based on the first clock signal, generate a second clock signal for an integrated circuit, wherein an amount of current drawn by the integrated circuit is based on a second frequency of the second clock signal; and
- an adjustment module configured to
 - receive an enable signal indicating whether the integrated circuit is being powered ON, and
 - in response to the enable signal indicating the integrated circuit is being powered ON,
 - (i) determine a predetermined frequency, and
 - (ii) generate a control signal based on the first clock signal, wherein the control signal adjusts the second frequency of the second clock signal to be between the predetermined frequency and the first frequency.

2. The system of claim 1, wherein the adjustment module is configured to (i) receive a signal indicating a predetermined period, and (ii) during the predetermined period, generate the control signal to adjust the second frequency of the second clock signal to be between the predetermined frequency and the first frequency.

3. The system of claim 2, wherein the adjustment module is configured to, during the predetermined period, generate the control signal to linearly or exponentially increase the second frequency of the second clock signal.

4. The system of claim 2, wherein the adjustment module is configured to generate the control signal to (i) start adjustment of the second frequency of the second clock signal at a beginning of the predetermined period, and (ii) complete adjustment of the second frequency of the second clock signal at an end of the predetermined period.

5. The system of claim 1, wherein the adjustment module is configured to increase the amount of current drawn by the integrated circuit by generating the control signal to adjust the second frequency of the second clock signal from the predetermined frequency to the first frequency.

6. The system of claim 5, wherein the adjustment module is configured to generate the control signal to increase the second frequency of the second clock signal from the predetermined frequency to the first frequency in response to the enable signal indicating the integrated circuit is being powered ON.

7. The system of claim 1, wherein the adjustment module is configured to decrease the amount of current drawn by the integrated circuit by generating the control signal to adjust the

9

second frequency of the second clock signal from the first frequency to the predetermined frequency.

8. The system of claim 7, wherein the adjustment module is configured to generate the control signal to decrease the second frequency of the second clock signal from the first frequency to the predetermined frequency in response to the enable signal indicating the integrated circuit is being powered OFF.

9. The system of claim 1, wherein the second clock module is configured to (i) compare the first clock signal and the control signal, and (ii) generate the second clock signal based on the comparison between the first clock signal and the control signal.

10. The system of claim 1, wherein:

the second clock module comprises an AND gate;

the AND gate comprises a first input, a second input, and an output;

the first input of the AND gate is configured to receive the first clock signal;

the second input of the AND gate is configured to receive the control signal; and

the output of the AND gate is configured to output the second clock signal.

11. The system of claim 1, further comprising the integrated circuit, wherein the integrated circuit comprises a switch, and wherein the integrated circuit is configured to, based on the second clock signal, transition the switch between a plurality of states.

12. A method comprising:

generating a first clock signal having a first frequency;

based on the first clock signal, generating a second clock signal for an integrated circuit, wherein an amount of current drawn by the integrated circuit is based on a second frequency of the second clock signal;

receiving an enable signal indicating whether the integrated circuit is being powered ON; and

responsive to the enable signal indicating the integrated circuit is being powered ON,

(i) determining a predetermined frequency, and

(ii) generating a control signal based on the first clock signal, wherein the control signal adjusts the second frequency of the second clock signal to between the predetermined frequency and the first frequency.

10

13. The method of claim 12, further comprising receiving a signal indicating a predetermined period,

wherein, during the predetermined period, the control signal is generated to adjust the second frequency of the second clock signal to be between the predetermined frequency and the first frequency.

14. The method of claim 13, wherein, during the predetermined period, the control signal is generated to linearly or exponentially increase the second frequency of the second clock signal.

15. The method of claim 13, wherein the control signal is generated to (i) start adjustment of the second frequency of the second clock signal at a beginning of the predetermined period, and (ii) complete adjustment of the second frequency of the second clock signal at an end of the predetermined period.

16. The method of claim 12, wherein the amount of current drawn by the integrated circuit is increased by generating the control signal to adjust the second frequency of the second clock signal from the predetermined frequency to the first frequency.

17. The method of claim 16, wherein the control signal is generated to increase the second frequency of the second clock signal from the predetermined frequency to the first frequency in response to the enable signal indicating the integrated circuit is being powered ON.

18. The method of claim 12, wherein the amount of current drawn by the integrated circuit is decreased by generating the control signal to adjust the second frequency of the second clock signal from the first frequency to the predetermined frequency.

19. The method of claim 18, wherein the control signal is generated to decrease the second frequency of the second clock signal from the first frequency to the predetermined frequency in response to the enable signal indicating the integrated circuit is being powered OFF.

20. The method of claim 12, further comprising comparing the first clock signal and the control signal,

wherein the second clock signal is generated based on the comparison between the first clock signal and the control signal.

* * * * *