

US008548390B2

(12) **United States Patent**  
**Pan**

(10) **Patent No.:** **US 8,548,390 B2**  
(45) **Date of Patent:** **\*Oct. 1, 2013**

(54) **METHOD AND SYSTEM FOR TRANSMITTER OUTPUT POWER COMPENSATION**

(75) Inventor: **Meng-An Pan**, Irvine, CA (US)

(73) Assignee: **Broadcom Corporation**, Irvine, CA (US)

(\*) Notice: Subject to any disclaimer, the term of this patent is extended or adjusted under 35 U.S.C. 154(b) by 58 days.

This patent is subject to a terminal disclaimer.

(21) Appl. No.: **12/751,836**

(22) Filed: **Mar. 31, 2010**

(65) **Prior Publication Data**

US 2010/0189042 A1 Jul. 29, 2010

**Related U.S. Application Data**

(63) Continuation of application No. 11/000,599, filed on Nov. 30, 2004, now Pat. No. 7,693,491.

(51) **Int. Cl.**  
**H04B 1/00** (2006.01)

(52) **U.S. Cl.**  
USPC ..... **455/69**; 455/67.11; 455/115.1; 455/126

(58) **Field of Classification Search**  
USPC ..... 455/69, 67.11, 115.1, 126, 39, 68, 455/13.4, 114.2, 522, 67.1, 63.1, 67.13, 67.14, 455/91, 115.2

See application file for complete search history.

(56) **References Cited**

**U.S. PATENT DOCUMENTS**

3,947,706 A 3/1976 Holmes  
4,122,719 A 10/1978 Carlson et al.

4,319,196 A	3/1982	Kwan	
4,523,155 A	6/1985	Walczak et al.	
4,672,842 A	6/1987	Hasselmann	
4,764,748 A	8/1988	Geen et al.	
4,970,456 A	11/1990	Holcomb et al.	
5,048,662 A	9/1991	Yamashita et al.	
5,054,313 A	10/1991	Fitzgerald et al.	
5,113,336 A	5/1992	Takahashi et al.	
5,287,555 A	2/1994	Wilson et al.	
5,295,746 A	3/1994	Friauf et al.	
5,335,362 A	8/1994	Vaisanen et al.	
5,339,046 A	8/1994	Kornfeld et al.	
5,408,697 A	4/1995	Price et al.	
5,448,770 A *	9/1995	Hietala et al. ....	455/126
5,471,654 A	11/1995	Okazaki et al.	
5,483,676 A	1/1996	Mahany et al.	
5,548,252 A	8/1996	Watanabe et al.	
5,551,067 A	8/1996	Hulkko et al.	
5,619,430 A	4/1997	Nolan et al.	

(Continued)

*Primary Examiner* — Pablo Tran

(74) *Attorney, Agent, or Firm* — Thomas|Horstemeyer, LLP.

(57) **ABSTRACT**

Aspects of compensating for transmitter output power may comprise sampling an on-chip transmitter circuit temperature at various time instants and determining a feedback temperature compensation value. At least one digital-to-analog converter may be adjusted by utilizing the feedback temperature compensation value, which may correspond to the sampled temperature. The digital-to-analog converter may be an I-component digital-to-analog converter and/or a Q-component digital-to-analog converter. At least a portion of the on-chip transmitter circuit may be characterized to determine power output dependence of the on-chip transmitter circuit on temperature variation of the on-chip transmitter circuit. Based on this characterization, a feedback temperature compensation value that may correspond to the sampled temperature may be used to adjust the digital-to-analog converter. The feedback temperature compensation value may be, for example, from a lookup table or an algorithm.

**36 Claims, 7 Drawing Sheets**

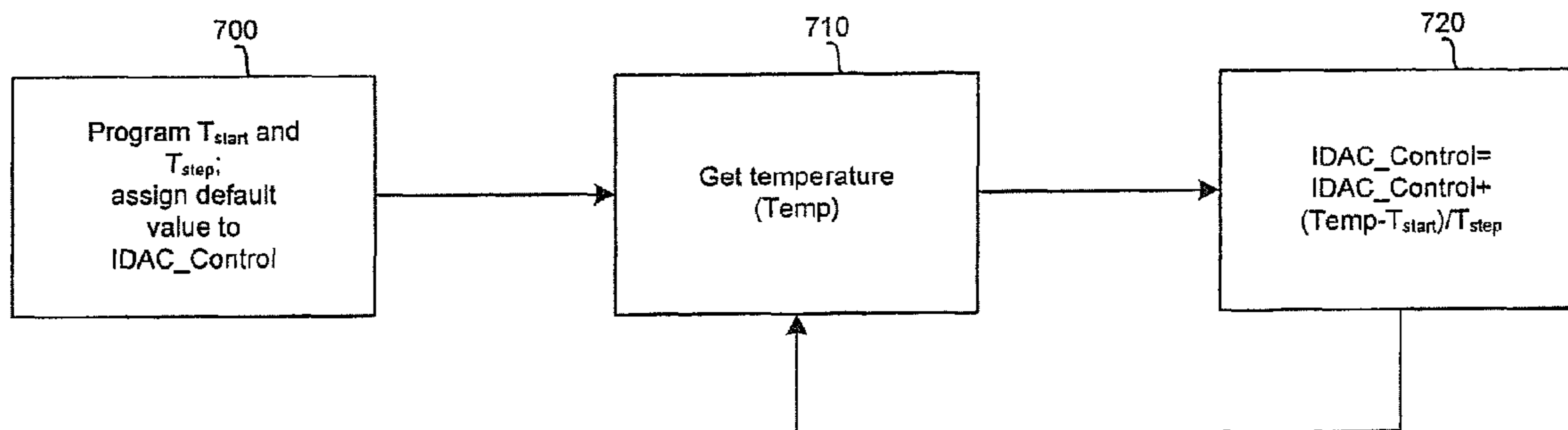

(56)

References Cited

U.S. PATENT DOCUMENTS

5,669,713 A	9/1997	Schwartz et al.	6,907,025 B2	6/2005	Demir et al.
5,678,209 A	10/1997	Strakovsky	6,945,306 B2	9/2005	Duncan et al.
5,722,056 A	2/1998	Horowitz et al.	6,985,751 B2	1/2006	Bartl et al.
5,732,332 A	3/1998	Iida	6,987,954 B2	1/2006	Nielsen
5,801,596 A	9/1998	Sakurai	6,999,737 B2	2/2006	Ishihara
5,832,373 A	11/1998	Nakanishi et al.	7,003,051 B2	2/2006	Francos et al.
5,859,567 A	1/1999	Black	7,026,874 B2	4/2006	Vaara et al.
5,890,057 A	3/1999	Dutkiewicz et al.	7,027,785 B2	4/2006	Summers et al.
5,915,213 A	6/1999	Iwatsuki et al.	7,046,976 B2	5/2006	Le Naour et al.
5,956,627 A	9/1999	Goos	7,050,765 B2	5/2006	Ammar et al.
5,961,215 A	10/1999	Lee et al.	7,061,987 B1	6/2006	Tan et al.
5,994,961 A	11/1999	Lunn et al.	7,068,985 B2	6/2006	Quilisch et al.
6,018,650 A	1/2000	Petsko et al.	7,103,029 B1	9/2006	Minowa
6,055,489 A	4/2000	Beatty et al.	7,120,393 B2	10/2006	Behzad et al.
6,115,441 A	9/2000	Douglass et al.	7,120,401 B2	10/2006	Vaidyanathan et al.
6,115,587 A	9/2000	Kim	7,126,509 B2	10/2006	Sit et al.
6,194,968 B1 *	2/2001	Winslow ..... 330/289	7,139,537 B2	11/2006	Nakayama
6,249,753 B1	6/2001	Mason et al.	7,146,138 B2	12/2006	Anvari
6,252,456 B1	6/2001	Baker et al.	7,725,087 B2 *	5/2010	Nielsen ..... 455/114.3
6,280,081 B1	8/2001	Blau et al.	2001/0001880 A1	5/2001	Watts, Jr.
6,282,247 B1	8/2001	Shen	2002/0074499 A1	6/2002	Butler
6,286,994 B1	9/2001	Boesel et al.	2002/0101937 A1	8/2002	Antonio et al.
6,288,395 B1	9/2001	Kuhnly et al.	2002/0147097 A1	10/2002	Dolecek
6,351,189 B1 *	2/2002	Hirvilampi ..... 330/296	2003/0045249 A1 *	3/2003	Nielsen ..... 455/118
6,356,191 B1	3/2002	Kirkpatrick et al.	2003/0072388 A1	4/2003	Francos et al.
6,405,062 B1	6/2002	Izaki	2003/0073420 A1	4/2003	Vaidyanathan et al.
6,449,534 B1	9/2002	Stewart	2003/0111984 A1	6/2003	Isham
6,465,997 B2	10/2002	Kussener	2003/0176202 A1	9/2003	Bartl et al.
6,473,603 B1	10/2002	Toncich et al.	2003/0166821 A1	8/2004	Varra et al.
6,489,835 B1	12/2002	Yu et al.	2004/0198295 A1	10/2004	Nicholls et al.
6,501,256 B1	12/2002	Jaussi et al.	2004/0203540 A1	10/2004	Anvari et al.
6,515,285 B1	2/2003	Marshall et al.	2004/0235438 A1	11/2004	Quilisch et al.
6,553,213 B1	4/2003	Kikuchi	2004/0266371 A1	12/2004	Summers et al.
6,567,763 B1	5/2003	Javanifard et al.	2005/0024245 A1	2/2005	Sit et al.
6,587,012 B1	7/2003	Farmer et al.	2005/0085198 A1	4/2005	Anvari
6,606,483 B1	8/2003	Baker et al.	2005/0129415 A1	6/2005	Tang
6,628,956 B2	9/2003	Bark et al.	2005/0136859 A1	6/2005	Anvari
6,633,750 B1	10/2003	Dacus et al.	2005/0136865 A1	6/2005	Dupuis
6,654,595 B1	11/2003	Dexter	2005/0227627 A1 *	10/2005	Cyr et al. .... 455/67.11
6,664,852 B2	12/2003	Pratt et al.	2005/0231987 A1	10/2005	Ananias
6,668,162 B1 *	12/2003	Murtojarvi ..... 455/115.1	2005/0249252 A1	11/2005	Sanchez
6,677,823 B2	1/2004	Terosky et al.	2005/0285763 A1	12/2005	Nguyen et al.
6,704,579 B2	3/2004	Woodhead et al.	2005/0288052 A1	12/2005	Carter et al.
6,711,389 B2	3/2004	Medl et al.	2006/0035596 A1	2/2006	Young et al.
6,718,164 B1	4/2004	Korneluk et al.	2006/0063497 A1	3/2006	Nielsen
6,724,176 B1	4/2004	Wong et al.	2006/0090731 A1	5/2006	Hoshino et al.
6,730,909 B2	5/2004	Butler	2006/0116082 A1	6/2006	Pan
6,765,372 B2	7/2004	Isham	2006/0159142 A1	7/2006	Sanchez
6,771,709 B2	8/2004	Huang et al.	2007/0103646 A1	5/2007	Young
6,775,638 B2	8/2004	Gauthier et al.	2007/0217299 A1	9/2007	Wang et al.
6,868,279 B2	3/2005	Sahlman et al.	2008/0001602 A1	1/2008	Schiano et al.
6,904,268 B2	6/2005	Leizerovich	2008/0007226 A1	1/2008	Lu et al.
			2009/0262861 A1	10/2009	Nielsen
			2011/0201287 A1 *	8/2011	Pratt et al. .... 455/126

\* cited by examiner

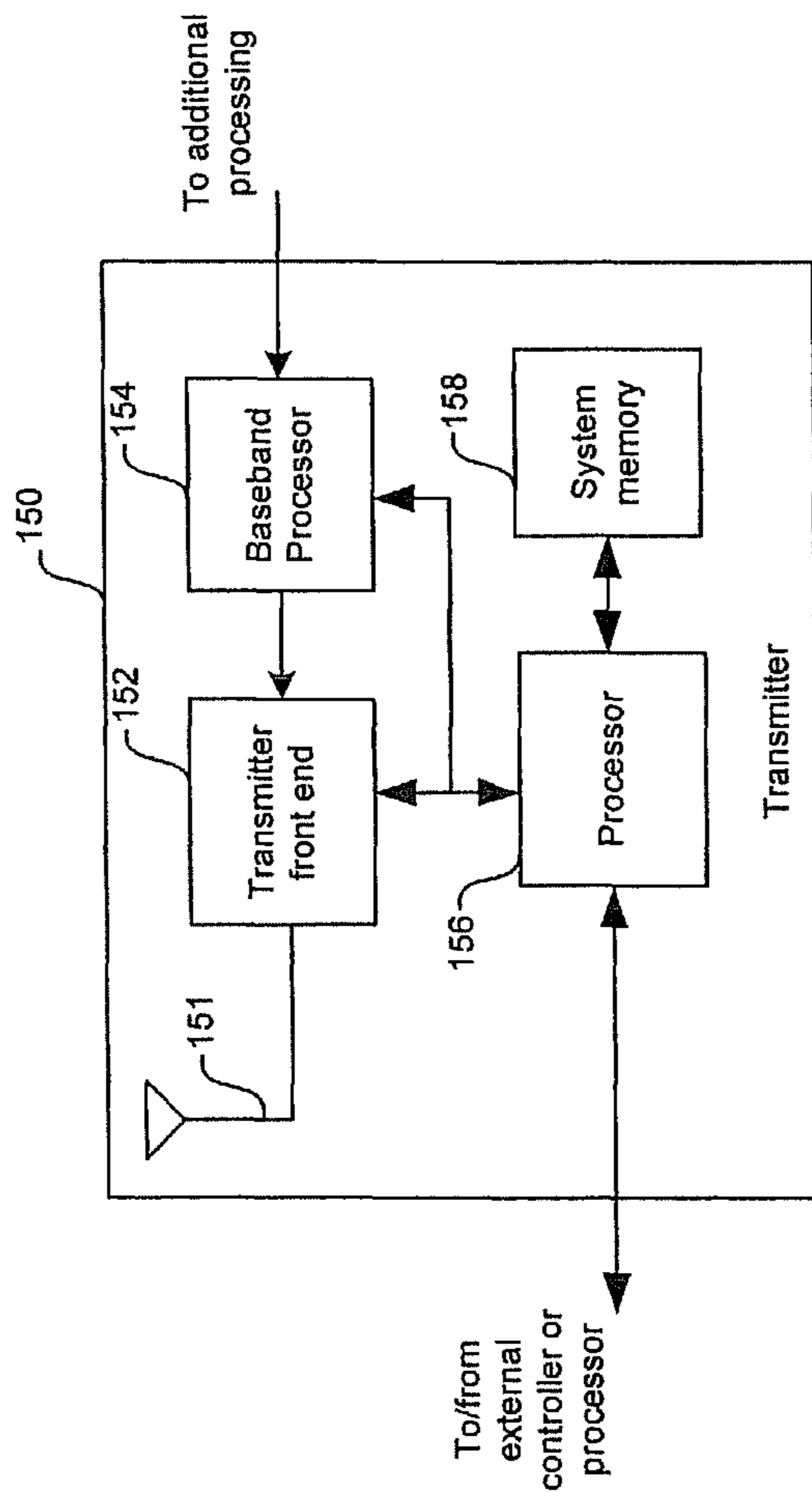

FIG. 1b

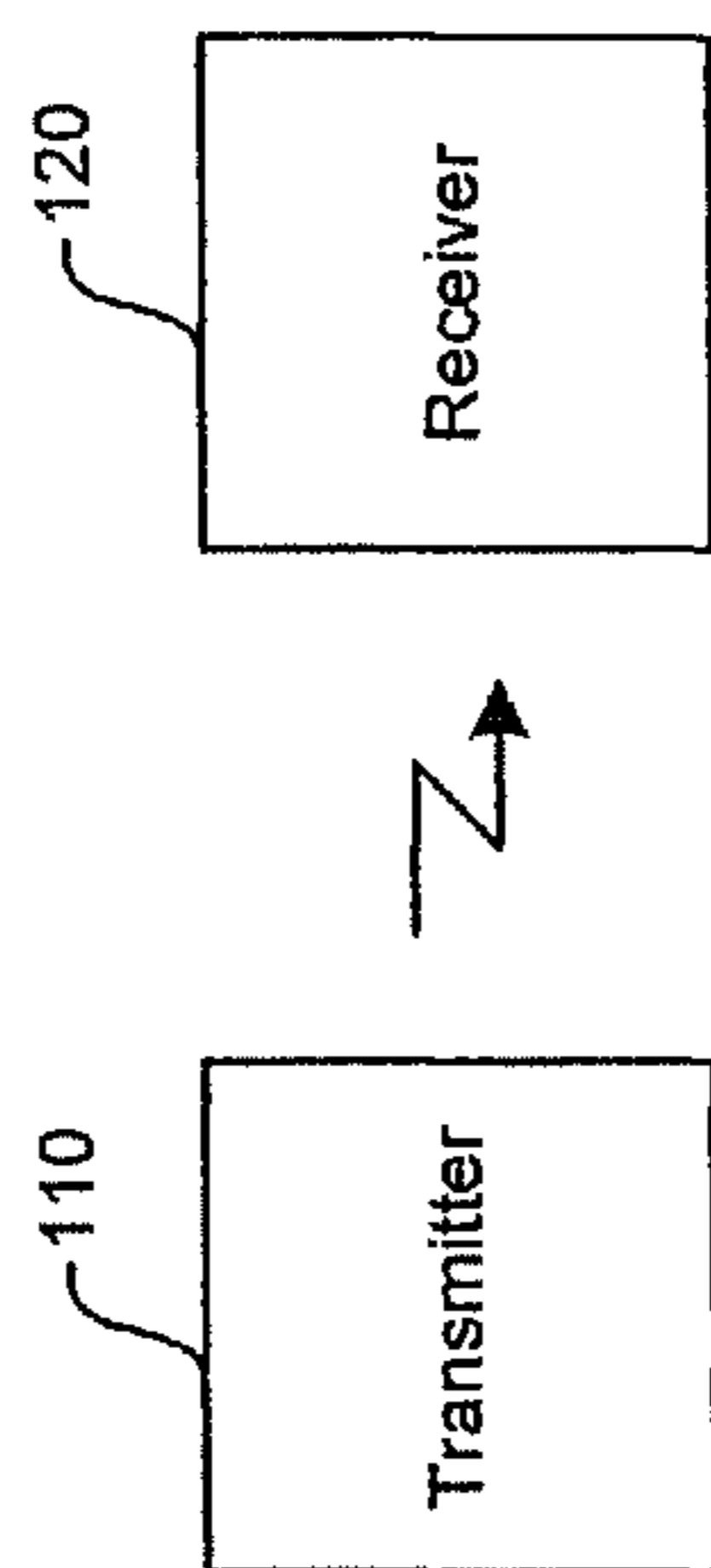

FIG. 1a

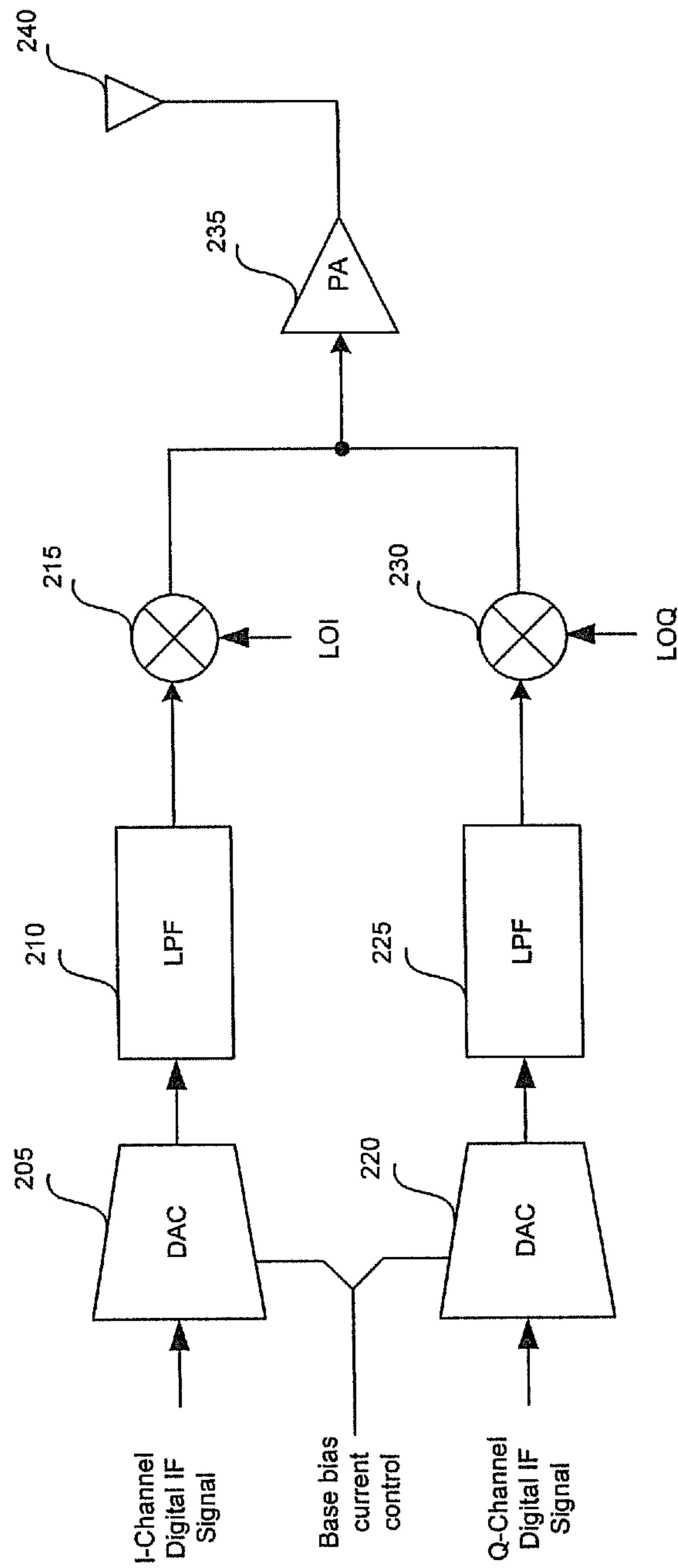

FIG. 2



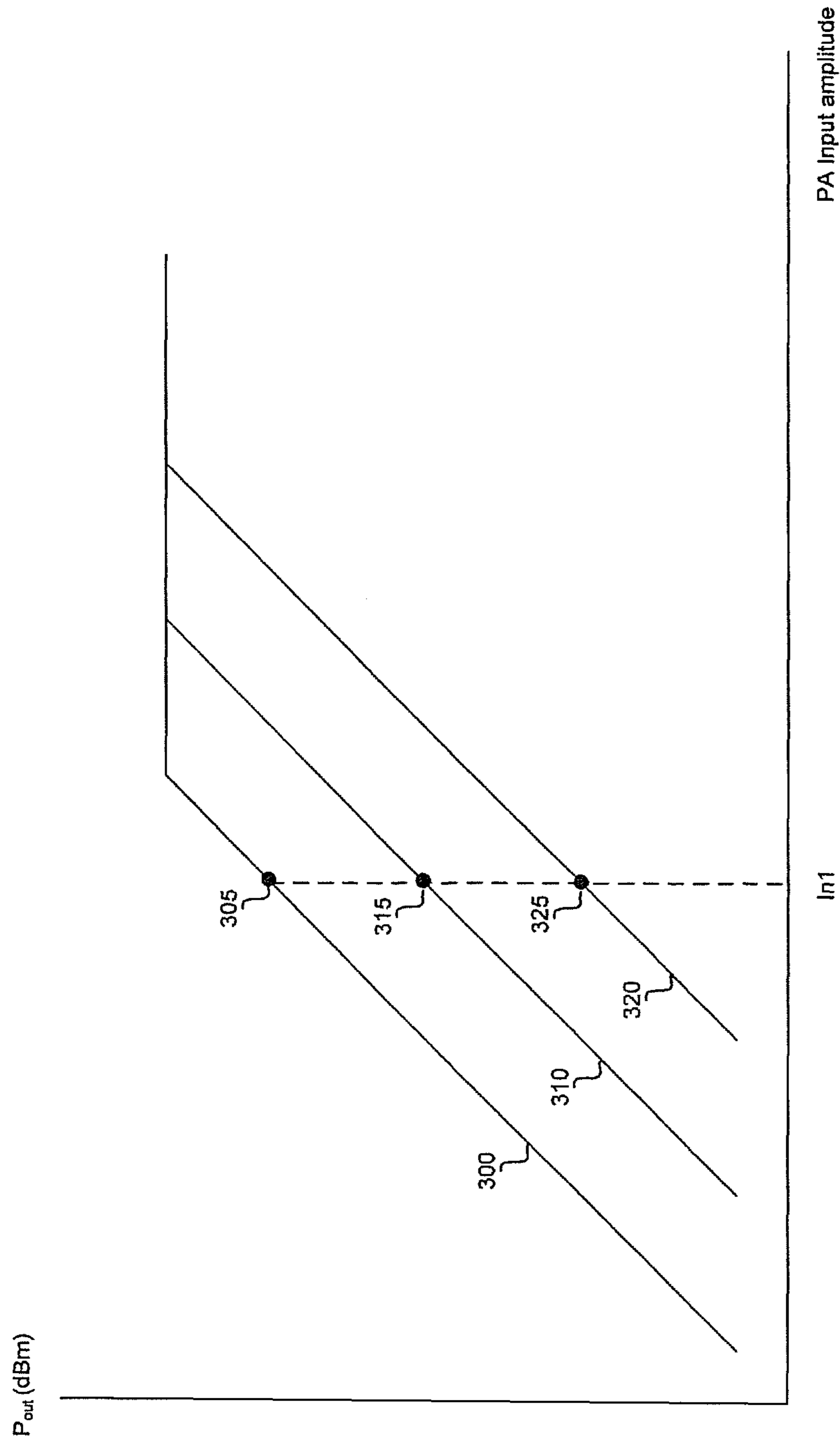

FIG. 3

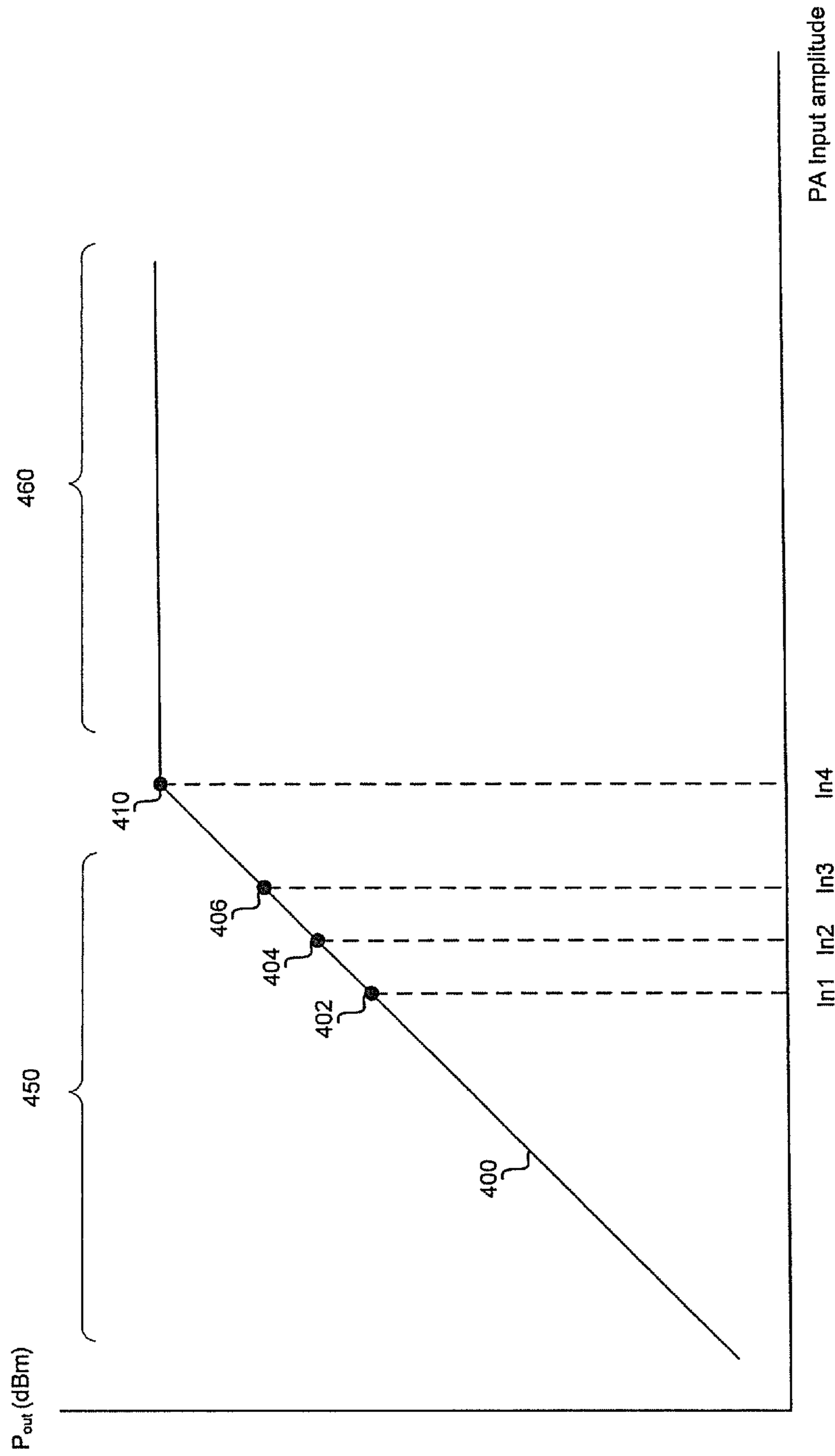

FIG. 4

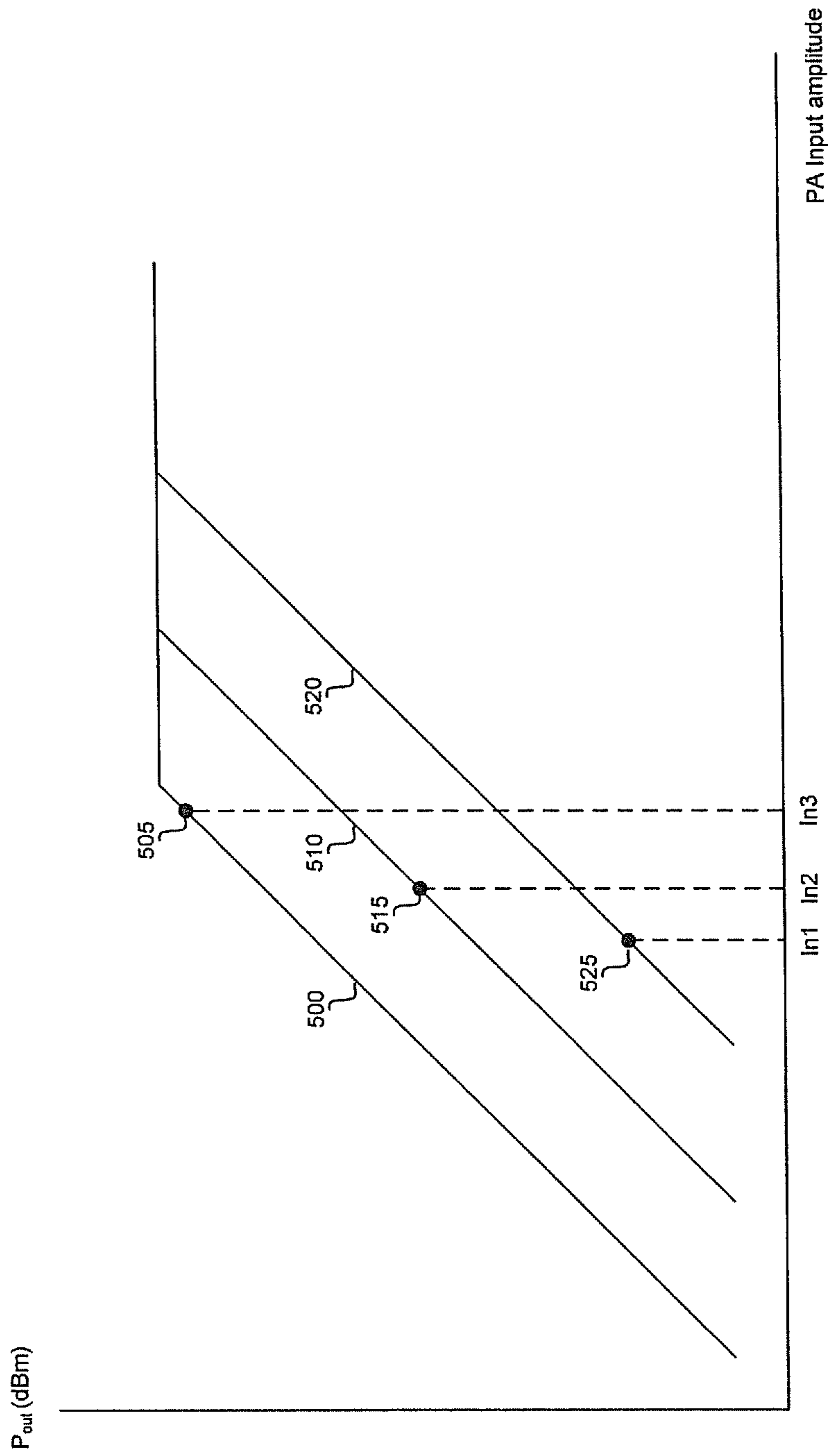

FIG. 5

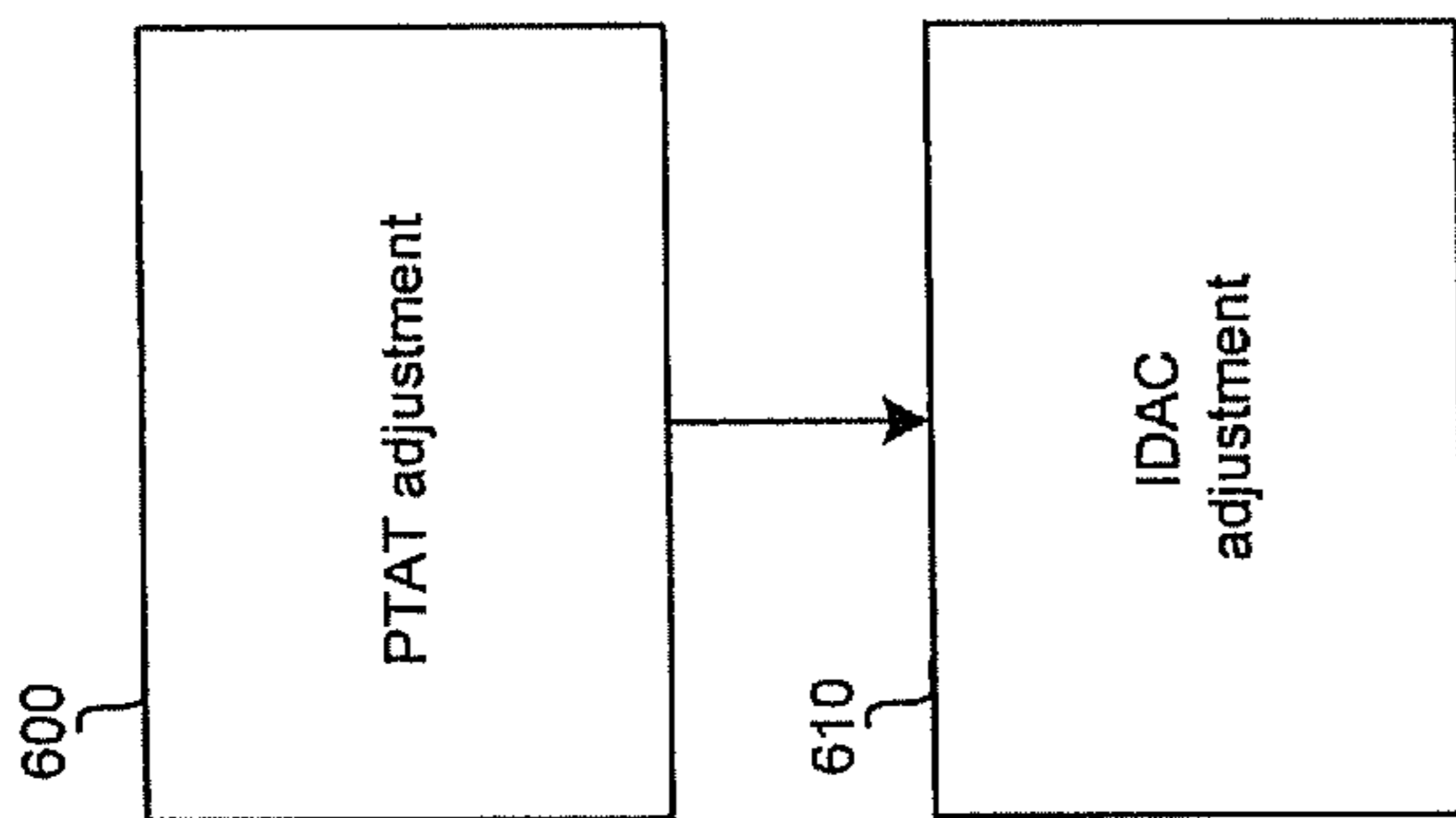

FIG. 6a

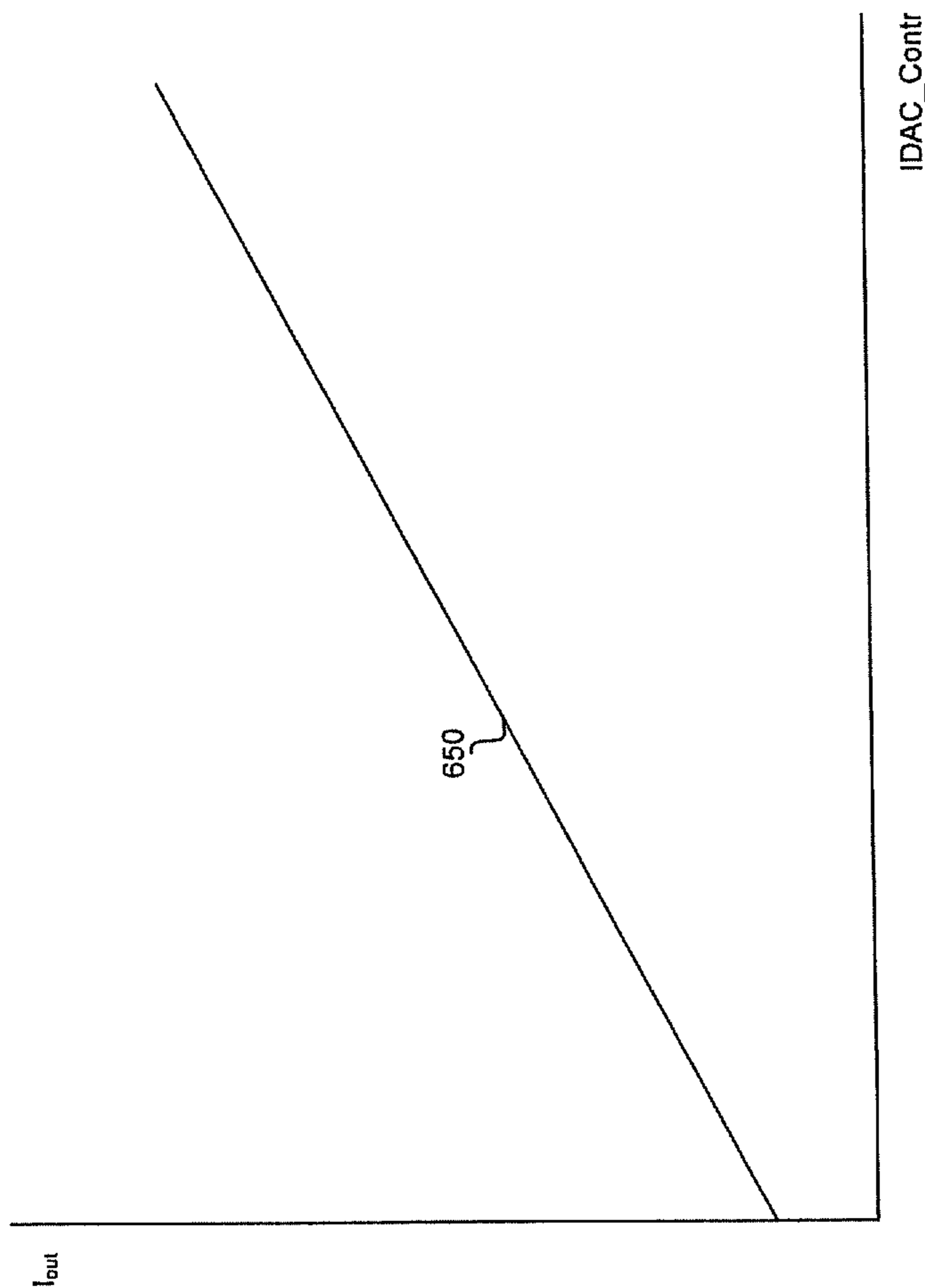

FIG. 6b



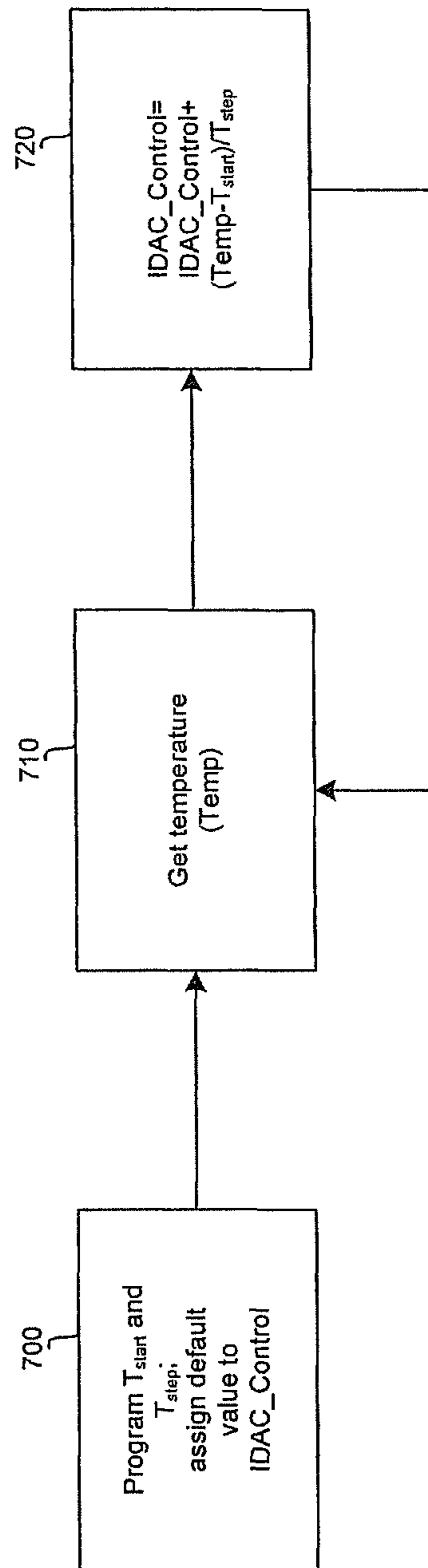

FIG. 7

## METHOD AND SYSTEM FOR TRANSMITTER OUTPUT POWER COMPENSATION

### CROSS-REFERENCE TO RELATED APPLICATIONS/INCORPORATION BY REFERENCE

The present application is a CONTINUATION of U.S. patent application Ser. No. 11/000,599, filed on Nov. 30, 2004, now U.S. Pat. No. 7,693,491.

This application makes reference to:  
U.S. patent application Ser. No. 11/000,622 filed on Nov. 30, 2004, now U.S. Pat. No. 7,119,620; and  
U.S. patent application Ser. No. 11/001,438 filed on Nov. 30, 2004, now U.S. Pat. No. 7,197,421.

The above stated applications are being incorporated herein by reference in their entirety.

### FIELD OF THE INVENTION

Certain embodiments of the invention relate to transmission of RF signals. More specifically, certain embodiments of the invention relate to a method and system for transmitter output power compensation.

### BACKGROUND OF THE INVENTION

In some conventional systems, a transmitter may broadcast radio frequency (RF) signals. Generally, RF signals are generated by upconverting baseband signals to intermediate frequency (IF) signals, and then further upconverting the IF signals to RF signals. The RF signals may be amplified by power amplifiers before being transmitted by a transmit antenna. Due to the proliferation wireless devices such as telephones, walkie-talkies, personal digital assistants (PDAs), and routers in home computer networks, a strong transmitted signal with a particular operating frequency band may cause interference for wireless devices operating within the same frequency band or other neighboring frequency bands.

Frequency reuse may be utilized to minimize the impact of interference between neighboring frequency bands. With frequency re-use, multiple transmitters may be assigned to utilize the same frequency, as long as the transmitters are far enough away from each other that their transmitted signals do not interfere with each other. The most common example of frequency re-use today may be cellular communication networks utilizing time-domain multiple access (TDMA) standard. In this regard, the same frequency is utilized in cells that are not in close proximity with each other so as to minimize the effects of interference. The network operators take much care in ensuring that various frequency bandwidths are spread out among the plurality of cells such that transmitted signal in one cell does not overpower other transmitted signals in other cells, which utilize the same frequency. Other frequency re-use examples are radio stations and television stations. The Federal Communications Commission (FCC) strictly regulates the broadcasting frequencies of the radio and television stations in order to keep neighboring stations from interfering with each other. The FCC also regulates the power output of the transmitting stations in order to keep distant stations from interfering with local stations that may be broadcasting at the same frequency.

In other instances, all transmitters may transmit in the same frequency bandwidth, but, still, care must be taken to ensure that no "rogue" transmitter transmits at too high of a power to "drown out" other transmitted signals. Code division multiple

access (CDMA) system is an example where all transmitters transmit over the same frequency bandwidth. In CDMA, special algorithms are used to code and/or decode a specific signal of interest to a transmitter and/or a receiver. Although all receivers may receive the transmitted signals, when a receiver's specific code is utilized by a receiver, all other signals except the desired signal appears as random noise. However, if a transmitter transmits too much power, then that signal would appear as too much noise to other receivers, and the desired signals at other receivers may be drowned out by the noise. Therefore, a transmitted signal must be transmitted with enough power to be able to be received and decoded by a receiver, and yet must not have too much power that it interferes with other signals.

Generally, controlling output power of a transmitter is extremely important to minimize interference with other transmitted signals while still providing enough transmitted signal strength to be able to be received and processed by a receiver. In addition, a transmitter of limited power source, for example, mobile communication handset with a small battery, may need to accurately control power output in order to maximize battery life. However, a problem is that performance of various electronic devices, for example, resistors or semiconductor devices on integrated circuits may be affected by temperature. As temperature rises, a resistor's resistance may increase, thereby affecting current and voltage, and vice versa as temperature decreases. Similarly, the current that a transistor on a chip may conduct may vary as temperature changes. The change in current and/or voltage may change the transmitter output power.

Further limitations and disadvantages of conventional and traditional approaches will become apparent to one of skill in the art, through comparison of such systems with some aspects of the present invention as set forth in the remainder of the present application with reference to the drawings.

### BRIEF SUMMARY OF THE INVENTION

Certain embodiments of the invention may be found in a method and system for transmitter output power compensation. Aspects of the method may comprise sampling an on-chip transmitter circuit temperature at a plurality of time instants and determining a feedback temperature compensation value at one or more time instants. At least one digital-to-analog converter may be adjusted by utilizing the feedback temperature compensation value, which may correspond to the sampled temperature. The digital-to-analog converter may be an I-component digital-to-analog converter and/or a Q-component digital-to-analog converter.

The method may comprise characterizing at least a portion of the on-chip transmitter circuit to determine power output dependence of the on-chip transmitter circuit on temperature variation of the on-chip transmitter circuit. Based on this characterization, a lookup table may be generated where the feedback temperature compensation values may correspond to the sampled temperatures. The feedback temperature compensation value may then be acquired from the lookup table for use in adjusting the digital-to-analog converter.

An alternate embodiment of the invention may calculate the feedback temperature compensation value via a compensation algorithm, in which the determined feedback temperature compensation value may be equal to:

$$((\text{an initial compensation value}) + ((\text{a present temperature} - \text{an initial temperature}) / (\text{a scale factor})))$$

Based on the characterization of the on-chip transmitter circuit, default values may be assigned to the initial compensa-



tion value, to the initial temperature, and to the scale factor. When these default values are utilized, an output of the digital-to-analog converter may be a desired value when the feedback temperature compensation value is equal to the initial compensation value and the sampled temperature is equal to the initial temperature. The temperature may be sampled at a periodic rate, and that rate may vary. The periodic rate may be varied in response to a changing rate of the sampled temperature.

Aspects of the system may comprise an on-chip temperature sensor circuit that samples temperature in an on-chip transmitter circuit at a plurality of time instants. At least one digital-to-analog converter in the on-chip transmitter circuit may be adjusted via a feedback temperature compensation value at one or more time instants, and the determined feedback temperature compensation value may correspond to the sampled temperature. The digital-to-analog converter may be an I-component digital-to-analog converter and/or a Q-component digital-to-analog converter.

At least a portion of the on-chip transmitter circuit may be characterized to determine the power output dependence of the on-chip transmitter circuit on temperature variation of the on-chip transmitter circuit. The temperature characterization of the on-chip transmitter circuit may lead to generation of a lookup table, in which the lookup table may be populated with feedback temperature compensation values that correspond to temperatures. Circuitry may be utilized to acquire the determined feedback temperature compensation value from the lookup table based on the sampled temperature, and, in this manner, compensate the power output of the transmitter for temperature variation.

Alternatively, the feedback temperature compensation value may be calculated utilizing a compensation algorithm, in which the determined feedback temperature compensation value may be equal to:

$$((\text{an initial compensation value}) + ((\text{a present temperature} - \text{an initial temperature}) / (\text{a scale factor}))).$$

Based on the characterization of the on-chip transmitter circuit, default values may be assigned to the initial compensation value, to the initial temperature, and to the scale factor. When these default values are utilized, the output of the digital-to-analog converter may be a desired value in instances when the feedback temperature compensation value is equal to the initial compensation value and the sampled temperature is equal to the initial temperature. The temperature may be sampled at a periodic rate, and that rate may vary in response to a changing rate of the sampled temperature.

Another embodiment of the invention may provide a machine-readable storage, having stored thereon, a computer program having at least one code section executable by a machine, thereby causing the machine to perform the steps as described above for transmitter output power compensation.

These and other advantages, aspects and novel features of the present invention, as well as details of an illustrated embodiment thereof, will be more fully understood from the following description and drawings.

#### BRIEF DESCRIPTION OF SEVERAL VIEWS OF THE DRAWINGS

FIG. 1a is a block diagram of an exemplary transmitter system and receiver system that may be utilized in connection with an embodiment of the invention.

FIG. 1b is a block diagram of an exemplary transmitter block of FIG. 1a, for example, that may be utilized in connection with an embodiment of the invention.

FIG. 2 is a block diagram illustrating at least a portion of an exemplary transmitter front end of FIG. 1b, for example, in accordance with an embodiment of the invention.

FIG. 3 is a graph illustrating transmitter power amplifier output power with respect to temperature, in accordance with an embodiment of the invention.

FIG. 4 is a graph illustrating transmitter power amplifier output power with respect to variance of power amplifier input, in accordance with an embodiment of the invention.

FIG. 5 is a graph illustrating transmitter power amplifier output power with respect to variances of power amplifier input and temperature, in accordance with an embodiment of the invention.

FIG. 6a is an exemplary flow diagram illustrating a two-stage compensation for transmitter output power, in accordance with an embodiment of the invention.

FIG. 6b is a graph illustrating output current in a digital-to-analog converter with respect to a control signal, in accordance with an embodiment of the invention.

FIG. 7 is an exemplary flow diagram of an algorithm for temperature compensation of transmitter output power, in accordance with an embodiment of the invention.

#### DETAILED DESCRIPTION OF THE INVENTION

Certain embodiments of the invention may be found in a method and system for temperature sensing for transmitter output power compensation. Various aspects of the invention may be utilized in, for example, a chip utilized in a mobile communication handset, which may be adapted to transmit RF signals. Transmit power specifications for the handset may have a very narrow range, for example, 3 decibels-milliwatt (dBm), plus or minus 2 decibels (dBs), and operating temperature variation for the handset may cause the transmit power to drift out of the specified power range. An embodiment of the invention may provide temperature sensing in order that appropriate compensation may be applied to transmitter power fluctuations due to temperature variations.

FIG. 1a is a block diagram of an exemplary transmitter system and receiver system that may be utilized in connection with an embodiment of the invention. Referring to FIG. 1a, there is shown a transmitter block 110 and a receiver block 120. The transmitter block 110 may comprise suitable logic, circuitry, and/or code that may be adapted to filter, modulate, and amplify a baseband signal to an RF signal, and transmit the RF signal. The receiver block 120 may comprise suitable logic, circuitry, and/or code that may be adapted to receive the RF signal and to demodulate the RF signal to the baseband signal.

In operation, the transmitter block 110 may be adapted to transmit RF signals over a wired or wireless medium. The receiver block 120 may be adapted to receive the RF signals and process them to a baseband signal that may be suitable for further processing, for example, as data or voice.

FIG. 1b is a block diagram of an exemplary transmitter system of FIG. 1a, for example, that may be utilized in connection with an embodiment of the invention. Referring to FIG. 1b, the RF transmitter system 150 may comprise a transmitting antenna 151, a transmitter front end 152, a baseband processor 154, a processor 156, and a system memory 158. The transmitter front end (TFE) 152 may comprise suitable logic, circuitry, and/or code that may be adapted to upconvert a baseband signal directly to an RF signal and to transmit the RF signal via a transmitting antenna 151. The



## 5

TFE **152** may also be adapted to upconvert a baseband signal to an IF signal, and/or upconvert the IF signal to an RF signal and then transmit the RF signal via the transmitting antenna **151**. The TFE **152** may be adapted to execute other functions, for example, filtering the baseband signal, and/or amplifying the baseband signal.

The baseband processor **154** may comprise suitable logic, circuitry, and/or code that may be adapted to process baseband signals, for example, convert a digital signal to an analog signal, and/or vice-versa. The processor **156** may be any suitable processor or controller such as a CPU or DSP, or any type of integrated circuit processor. The processor **156** may comprise suitable logic, circuitry, and/or code that may be adapted to control the operations of the TFE **152** and/or the baseband processor **154**. For example, the processor **156** may be utilized to update and/or modify programmable parameters and/or values in a plurality of components, devices, and/or processing elements in the TFE **152** and/or the baseband processor **154**. Control and/or data information, which may include the programmable parameters, may be transferred from at least one controller and/or processor, which may be external to the RF transmitter system **150**, to the processor **156**. Similarly, the processor **156** may be adapted to transfer control and/or data information, which may include the programmable parameters, to at least one controller and/or processor, which may be externally coupled to the RF transmitter block **110**.

The processor **156** may utilize the received control and/or data information, which may comprise the programmable parameters, to determine an operating mode of the TFE **152**. For example, the processor **156** may be utilized to select a specific frequency for a local oscillator, or a specific gain for a variable gain amplifier. Moreover, the specific frequency selected and/or parameters needed to calculate the specific frequency, and/or the specific gain value and/or the parameters needed to calculate the specific gain, may be stored in the system memory **158** via the processor **156**. The information stored in system memory **158** may be transferred to the TFE **152** from the system memory **158** via the processor **156**. The system memory **158** may comprise suitable logic, circuitry, and/or code that may be adapted to store a plurality of control and/or data information, including parameters needed to calculate frequencies and/or gain, and/or the frequency value and/or gain value.

FIG. **2** is a block diagram illustrating at least a portion of the exemplary transmitter front end of FIG. **1b**, for example, in accordance with an embodiment of the invention. Referring to FIG. **2**, there is shown digital-to-analog converters **205** and **220**, low pass filters **210** and **225**, mixers **215** and **230**, a power amplifier **235** and an antenna **240**.

The digital-to-analog converters (DACs) **205** and **220** may comprise logic, circuitry, and/or code that may be adapted to convert a digital input signal to an analog output signal. The digital input signal may be a plurality of bits, and the rate of conversion of the digital input to analog output may be predetermined or under external control, for example, under programmed control by a controller. The controller may be external to the RF transmitter system **150**, or part of the RF transmitter system **150** (FIG. **1b**), for example, the processor **156** (FIG. **1b**).

The DACs **205** and **220** may also comprise at least one input that may control base bias current in each DAC. A base bias current in a DAC may be the output current that may correspond to an input digital value that may represent a value of, for example, one. For any other input digital value that may represent a different value, for example, five, the output current of the DAC may be five times the base bias current.

## 6

The base bias current may be fixed at a pre-determined value, or it may be dynamically changed by a controller, for example, the processor **156** (FIG. **1b**).

The low pass filters **210** and **225** may comprise logic, circuitry, and/or code that may be adapted to selectively pass signals below a pre-determined frequency while attenuating signals greater than that frequency. The mixers **215** and **230** may comprise suitable logic, circuitry, and/or code that may be adapted to have as inputs two signals, and generate an output signal, which may be a difference of the frequencies of the two input signals and/or a sum of the frequencies of the two input signals. The power amplifier **235** may comprise suitable logic, circuitry, and/or code that may be adapted to amplify input signals and output the amplified signals. The antenna **240** may comprise suitable logic, circuitry, and/or code that may be adapted to receive RF signals and transmit the RF signals over a wired or wireless medium.

In operation, input signals for I-channel digital IF and Q-channel digital IF may be received by the DACs **205** and **220**, respectively, and the DACs **205** and **220** may be adapted to convert the digital signals to analog signals. The DACs **205** and **220** may communicate the analog output signals to the low pass filters **210** and **225**, respectively. The low pass filters **210** and **225** may filter the analog signals from the DACs **205** and **220**, and may communicate the filtered signals to mixers **215** and **230**, respectively. The mixers **215** and **230** may utilize local oscillator signals LOI and LOQ, respectively, to upconvert the filtered signals to RF signals. The outputs of the mixers **215** and **230** may be communicated to an input of the power amplifier **235** where the outputs of the mixers **215** and **230** may add together to a single RF signal. The power amplifier **235** may amplify the single RF signal and communicate an amplified RF signal to a transmitting antenna **240**. The transmitting antenna **240** may transmit the amplified RF signal.

FIG. **3** is a graph illustrating transmitter power amplifier output power ( $P_{out}$ ) with respect to temperature, in accordance with an embodiment of the invention. Referring to FIG. **3**, there is shown three plots **300**, **310** and **320**, and a plurality of specific power points **305**, **315** and **325**. The plot **300** may illustrate the output power of the power amplifier **235** (FIG. **2**) at  $-40^{\circ}\text{C}$ . The plot **310** may illustrate the output power of the power amplifier **235** at  $27^{\circ}\text{C}$ ., and the plot **320** may illustrate the output power of the power amplifier **235** at  $105^{\circ}\text{C}$ . The specific power point **315** may be the nominal output power of the power amplifier **235** for an input In1 at a nominal temperature of  $27^{\circ}\text{C}$ . For the same input In1, the specific power point **305** may illustrate that at  $-40^{\circ}\text{C}$ ., the power amplifier **235** may output a higher than nominal output power. Similarly, the specific power point **325** may illustrate the lower than the nominal output power of the power amplifier **235** at  $105^{\circ}\text{C}$ .

FIG. **4** is a graph illustrating transmitter power amplifier output power ( $P_{out}$ ) with respect to variance of a power amplifier (PA) input, in accordance with an embodiment of the invention. Referring to FIG. **4**, there is shown a graph **400** with specific power points **402**, **404** and **406**, and saturation point **410**. The graph **400** may illustrate the output power of the power amplifier **235** (FIG. **2**) as a function of a power amplifier input, at a constant temperature. The output power of the power amplifier **235** may be a linear function of the input up to the saturation point **410**. However, beyond the saturation point **410**, the output power may not increase linearly with respect to the increase in the input amplitude. Therefore, care should be taken that the power amplifier input does not increase beyond In4, as the power amplifier **235** may saturate and generate undesired, non-linear output.



In the linear region **450** to the left of the saturation point **410**, power amplifier inputs of In1, In2 and In3 may correspond to specific power points of **402**, **404** and **406**, in which there is a linear relationship between power amplifier inputs and the output powers of the power amplifier **235**. In the non-linear region **460**, the output of the power amplifier **235** may saturate and may not increase linearly as the input amplitude increases.

FIG. **5** is a graph illustrating transmitter power amplifier output power ( $P_{out}$ ) with respect to variances of power amplifier (PA) input and temperature, in accordance with an embodiment of the invention. Referring to FIG. **5**, there is shown plots **500**, **510** and **520**, and a plurality of specific power points **505**, **515** and **525**. The plot **500** may illustrate the output power of the power amplifier **235** (FIG. **2**) at  $-40^{\circ}$  C. The plot **510** may illustrate the output power of the power amplifier **235** at  $27^{\circ}$  C., and the plot **520** may illustrate the output power of the power amplifier **235** at  $105^{\circ}$  C.

Unlike the specific power points **305**, **315** and **325** in FIG. **3** that have a common power amplifier input In1, the specific power points **505**, **515** and **525** may correspond to three distinct power amplifier inputs In1 In2 and In3. The three distinct power amplifier inputs In1, In2 and In3 may be due to a temperature effect on devices that may generate inputs for the power amplifier **235**, for example, the DACs **205** and **220** (FIG. **2**). The DACs **205** and **220** may generate a constant output current for a specific digital input value. However, as temperature changes, the output current of the DACs **205** and **220** may vary even though the digital input value may remain constant. The outputs of the mixers **215** and **230** (FIG. **2**) may also vary with temperature.

FIG. **6a** is an exemplary flow diagram illustrating a two-stage compensation for transmitter output power, in accordance with an embodiment of the invention. Referring to FIGS. **2** and **6a**, there is shown steps **600** and **610** that may be used to compensate for temperature effects in transmitter output power, which may be an output of the power amplifier **235**. In step **600**, some devices, such as the power amplifier **235** and the DACs **205** and **220**, may utilize proportional to absolute temperature (PTAT) compensation to minimize output variation due to temperature. PTAT compensation may adjust the output of a device as temperature changes in order to attempt to keep the output constant for a constant input. However, even with the PTAT compensation, the output power of the power amplifier **235** may show slight variations with temperature change, even when digital input values to the DACs **205** and **220** (FIG. **2**) may remain constant.

In step **610**, a temperature dependant current compensation may be generated for bias currents in DACs **205** and **220**. The DACs **205** and **220** may have a base bias current that may be generated as an output when the input digital value is equivalent to, for example, one. As the input digital value increases, the output current of the DAC may increase to the same multiple of the base bias current as the input digital value is a multiple of the value one. However, the base bias current may need to be adjusted to a different current value as temperature changes in order to keep the output power of the power amplifier **235** constant at different temperatures for the same digital input value to the DACs **205** and **220**.

FIG. **6b** is a graph illustrating an output current ( $I_{out}$ ) in a digital-to-analog converter with respect to a control signal, in accordance with an embodiment of the invention. Referring to FIG. **6b**, there is shown a graph **650** of the output current of a DAC, for example, the DAC **205** and/or **220** (FIG. **2**). The base bias current of the DAC **205** and/or **220** may be adjusted by an input control signal IDAC\_Control, which may be generated based on a determination of the relationship

between the temperature of a transmitter circuit, for example, the TFE **152** (FIG. **1b**), and the base bias current needed for the DAC **205** and/or **220**. For a constant digital input value, the output current of the DAC **205** and/or **220**, which may depend on the base bias current, may be adjusted by the input control signal IDAC\_Control.

As temperature of the transmitter circuit, for example, the TFE **152**, changes, the input control signal IDAC\_Control to the DAC **205** and/or **220** may be adjusted, utilizing the determination of the relationship between the temperature of the transmitter circuit and the base bias current for the DAC **205** and/or **220**.

FIG. **7** is an exemplary flow diagram of an algorithm for temperature compensation of a transmitter output power, in accordance with an embodiment of the invention. In step **700**, start values for  $T_{start}$  and  $T_{step}$  may be programmed, and IDAC\_Control may be assigned a default value. In step **710**, a temperature of the transmitter circuit may be determined. In step **720**, the new IDAC\_Control value may be calculated.

Referring to FIGS. **1b**, **2** and **7**, there is shown a plurality of steps compensating for variation of transmitter output power due to temperature. In step **700**, the start values  $T_{start}$  and  $T_{step}$  may be programmed into a register or memory location, and IDAC\_Control may be assigned a default value.  $T_{start}$  may be a temperature relating to at least a portion of the transmitter system illustrated in FIG. **2**.  $T_{step}$  may be a conversion factor that may be utilized to determine the base bias current for the DACs **205** and **220**.  $T_{start}$ ,  $T_{step}$  and IDAC\_Control may be utilized by a processor, for example, processor **156**, to calculate a value for the IDAC\_Control. The start values for  $T_{start}$  and  $T_{step}$ , and the default IDAC\_Control value may be determined by measuring various parameters of at least a portion of the transmitter system **150**, for example, the base bias currents for the DACs **205** and **220**, and/or the output currents of the DACs **205** and **220**, and/or the output of the power amplifier **235**.

In step **710**, temperature of at least a portion of the transmitter system **150** may be determined. This temperature may be utilized by a processor, for example processor **156**, to calculate a value for the IDAC\_Control. The temperature may be determined at a plurality of time instants, and the time instants may optionally be periodic. In step **720**, a processor, for example processor **156**, may calculate a value for the IDAC\_Control by utilizing the following equation:

$$IDAC\_Control = IDAC\_Control + ((\text{Determined Temperature}) - T_{start}) / T_{step}$$

The newly calculated value for IDAC\_Control, which may be the same as a previous value for IDAC\_Control, may be communicated to the DACs **205** and **220**.

Although specific embodiments of the invention may have been described, for example, the equation for IDAC\_Control, the invention need not be so limited. Other equations may be utilized for transmitter output power compensation. Additionally, a lookup table may be utilized in place of the equation for IDAC\_Control. In this embodiment, a digital value, which may be a temperature in Kelvin scale, or Celsius scale or Fahrenheit scale, or a value that may correspond to any of the temperature scales, may be utilized as an input to a lookup table. The output of the lookup table may be the IDAC\_Control. Furthermore, the IDAC\_Control may be separately calculated, or looked up, for the two DACs **205** and **220**.

Accordingly, the present invention may be realized in hardware, software, or a combination of hardware and software. The present invention may be realized in a centralized fashion in at least one computer system, or in a distributed fashion where different elements are spread across several intercon-



nected computer systems. Any kind of computer system or other apparatus adapted for carrying out the methods described herein is suited. A typical combination of hardware and software may be a general-purpose computer system with a computer program that, when being loaded and executed, controls the computer system such that it carries out the methods described herein.

The present invention may also be embedded in a computer program product, which comprises all the features enabling the implementation of the methods described herein, and which when loaded in a computer system is able to carry out these methods. Computer program in the present context means any expression, in any language, code or notation, of a set of instructions intended to cause a system having an information processing capability to perform a particular function either directly or after either or both of the following: a) conversion to another language, code or notation; b) reproduction in a different material form.

While the present invention has been described with reference to certain embodiments, it will be understood by those skilled in the art that various changes may be made and equivalents may be substituted without departing from the scope of the present invention. In addition, many modifications may be made to adapt a particular situation or material to the teachings of the present invention without departing from its scope. Therefore, it is intended that the present invention not be limited to the particular embodiment disclosed, but that the present invention will include all embodiments falling within the scope of the appended claims.

What is claimed is:

1. A wireless communication device, comprising:  
a sensor circuit configured to sample a temperature of a wireless transmitter of the wireless communication device at a plurality of time instants; and  
a digital-to-analog converter configured to receive a digital intermediate frequency (IF) signal of the wireless transmitter, wherein a bias current for the digital-to-analog converter is adjusted via a feedback temperature compensation value corresponding to the sampled temperature at a particular time instant of the plurality of time instants.
2. The wireless communication device according to claim 1, wherein the digital-to-analog converter comprises an I-component digital-to-analog converter or a Q-component digital-to-analog converter.
3. The wireless communication device according to claim 1, comprising a lookup table of feedback temperature compensation values that correspond to the sampled temperature.
4. The wireless communication device according to claim 1, wherein the determined feedback temperature compensation value is calculated using a compensation algorithm that uses at least the following: an initial compensation value, a present temperature, an initial temperature and a scaling factor.
5. The wireless communication device according to claim 4, wherein one or more default values are assigned to one or more of the following: the initial compensation value, the present temperature, the initial temperature and the scaling factor.
6. The wireless communication device according to claim 4, wherein an output of the digital-to-analog converter is a desired value when the determined feedback temperature compensation value is equal to the initial compensation value and the sampled temperature is equal to the initial temperature.

7. The wireless communication device according to claim 1, wherein the mobile wireless communication device has a transmit power specification of approximately 3 dBm.

8. The wireless communication device according to claim 1, wherein the wireless transmitter comprises a transmitter front end and a baseband processor, and wherein the sensor circuit samples the temperature of the wireless transmitter at the transmitter front end.

9. The wireless communication device according to claim 1, wherein the wireless communication device is a mobile wireless communication device.

10. The wireless communication device according to claim 9, wherein the mobile wireless communication device comprises a telephone.

11. The wireless communication device according to claim 1, wherein the wireless transmitter is part of one or more of the following: a telephone, a walkie-talkie and a personal digital assistant (PDA).

12. The wireless communication device according to claim 1, wherein the wireless transmitter is part of a router in a home network.

13. The wireless communication device according to claim 1, wherein the wireless communication device is a mobile wireless communication device that participates in a cellular communication network.

14. The wireless communication device according to claim 1, wherein the wireless communication device supports time-domain multiple access (TDMA) communications.

15. The wireless communication device according to claim 1, wherein the wireless communication device supports code division multiple access (CDMA) communications.

16. A method for controlling an output of a wireless transmitter, comprising:

- determining a feedback temperature compensation value at a particular one of a plurality of time instants at which a temperature of at least a portion of the wireless transmitter is sampled, where the determined feedback temperature compensation value corresponds to the sampled temperature; and
- adjusting a bias current for one or more digital-to-analog converters of the wireless transmitter, where the bias current is adjusted using the determined feedback temperature compensation value, wherein the one or more digital-to-analog converters receive one or more digital intermediate frequency (IF) signals.

17. The method according to claim 16, wherein the wireless transmitter comprises a transmitter front end and a baseband processor, and wherein the at least a portion of the wireless transmitter that is temperature sampled is the transmitter front end.

18. The method according to claim 16, wherein the one or more digital-to-analog converters comprise an I-component digital-to-analog converter and a Q-component digital-to-analog converter.

19. The method according to claim 16, comprising acquiring the determined feedback temperature compensation value from a lookup table of feedback temperature compensation values corresponding to the sampled temperature.

20. The method according to claim 16, wherein the determined feedback temperature compensation value is calculated using a compensation algorithm, wherein the calculation of the determined feedback temperature compensation value uses at least an initial compensation value, the sampled temperature, an initial temperature and a scaling factor.

21. The method according to claim 20, comprising assigning a default value to the initial compensation value.



## 11

22. The method according to claim 20, comprising assigning a default value to the initial temperature.

23. The method according to claim 20, comprising assigning a default value to the scaling factor.

24. The method according to claim 20, wherein an output of the one or more of the digital-to-analog converters is a desired value when the determined feedback temperature compensation value is equal to the initial compensation value and the sampled temperature is equal to the initial temperature.

25. The method according to claim 16, wherein the wireless transmitter is part of a mobile wireless communication device.

26. The method according to claim 25, wherein the mobile wireless communication device comprises a telephone.

27. The method according to claim 16, wherein the wireless transmitter is part of one or more of the following: a telephone, a walkie-talkie and a personal digital assistant (PDA).

28. The method according to claim 16, wherein the wireless transmitter is part of a router in a home network.

29. The method according to claim 16, wherein the wireless transmitter is part of a mobile wireless communication device that participates in a cellular communication network.

30. The method according to claim 16, wherein the wireless transmitter is part of a wireless communication device that supports time-domain multiple access (TDMA) communications.

31. The method according to claim 16, wherein the wireless transmitter is part of a wireless communication device that supports code division multiple access (CDMA) communications.

## 12

32. A non-transitory machine-readable storage media having stored thereon a program that, when executed by processing circuitry, causes the processing circuitry to:

determine a feedback temperature compensation value at a particular one of a plurality of time instants based at least in part upon a corresponding sampled temperature of at least a portion of a wireless transmitter; and

adjust a bias current for a digital-to-analog converter of the wireless transmitter in response to the determined feedback temperature compensation value, wherein the digital-to-analog converter is configured to receive a digital intermediate frequency (IF) signal.

33. The non-transitory machine-readable storage media of claim 32, wherein the feedback temperature compensation value is determined from a lookup table of feedback temperature compensation values corresponding to the sampled temperature.

34. The non-transitory machine-readable storage media of claim 32, wherein the feedback temperature compensation value is determined using a compensation algorithm based at least in part upon the sampled temperature.

35. The non-transitory machine-readable storage media of claim 32, wherein the compensation algorithm determines the determined feedback temperature compensation value based upon at least an initial compensation value, the sampled temperature, an initial temperature and a scaling factor.

36. The non-transitory machine-readable storage media of claim 32, wherein the wireless transmitter is part of a wireless communication device.

\* \* \* \* \*