

US008546951B2

(12) **United States Patent**
Oganesian

(10) **Patent No.:** **US 8,546,951 B2**
(45) **Date of Patent:** **Oct. 1, 2013**

(54) **3D INTEGRATION MICROELECTRONIC ASSEMBLY FOR INTEGRATED CIRCUIT DEVICES**

(75) Inventor: **Vage Oganesian**, Sunnyvale, CA (US)

(73) Assignee: **Optiz, Inc.**, Palo Alto, CA (US)

(*) Notice: Subject to any disclaimer, the term of this patent is extended or adjusted under 35 U.S.C. 154(b) by 88 days.

(21) Appl. No.: **13/157,207**

(22) Filed: **Jun. 9, 2011**

(65) **Prior Publication Data**

US 2012/0313255 A1 Dec. 13, 2012

(51) **Int. Cl.**
H01L 23/48 (2006.01)
H01L 23/52 (2006.01)
H01L 29/40 (2006.01)

(52) **U.S. Cl.**
USPC **257/774**; 257/E23.011; 438/125

(58) **Field of Classification Search**
USPC 257/774, E23.011, E21.505; 438/125
See application file for complete search history.

(56) **References Cited**

U.S. PATENT DOCUMENTS

5,208,478	A *	5/1993	Solomon	257/443
8,288,243	B2 *	10/2012	Jacobsen et al.	438/424
2004/0251525	A1	12/2004	Zilber		
2005/0104179	A1	5/2005	Zilber		
2005/0205977	A1	9/2005	Zilber		
2007/0077727	A1*	4/2007	Huang et al.	438/444
2007/0138498	A1	6/2007	Zilber		
2007/0190691	A1	8/2007	Humpston		
2007/0190747	A1	8/2007	Humpston		
2008/0012115	A1	1/2008	Zilber		

2008/0017879	A1	1/2008	Zilber
2008/0083976	A1	4/2008	Haba
2008/0083977	A1	4/2008	Haba
2008/0099900	A1	5/2008	Oganesian
2008/0099907	A1	5/2008	Oganesian
2008/0116544	A1	5/2008	Grinman
2008/0116545	A1	5/2008	Grinman
2008/0150121	A1	6/2008	Oganesian
2008/0246136	A1	10/2008	Haba
2009/0115047	A1	5/2009	Haba
2009/0160065	A1	6/2009	Haba
2009/0212381	A1	8/2009	Crisp
2010/0053407	A1	3/2010	Crisp
2010/0225006	A1	9/2010	Haba
2010/0230812	A1	9/2010	Oganesian
2011/0012259	A1	1/2011	Grinman
2011/0031629	A1	2/2011	Haba

(Continued)

OTHER PUBLICATIONS

U.S. Appl. No. 13/157,193, filed Jun. 9, 2011, Oganesian, Vage.

(Continued)

Primary Examiner — Phuc Dang
(74) *Attorney, Agent, or Firm* — DLA Piper LLP (US)

(57) **ABSTRACT**

A 3D interposer (and method of making same) that includes a crystalline substrate handler having opposing first and second surfaces, with a cavity formed into the first surface. A layer of insulation material is formed on the surface of the handler that defines the cavity. The cavity is filled with a compliant dielectric material. A plurality of electrical interconnects is formed through the interposer. Each electrical interconnect includes a first hole formed through the crystalline substrate handler extending from the second surface to the cavity, a second hole formed through the compliant dielectric material so as to extend from and be aligned with the first hole, a layer of insulation material formed along a sidewall of the first hole, and conductive material extending through the first and second holes.

9 Claims, 6 Drawing Sheets

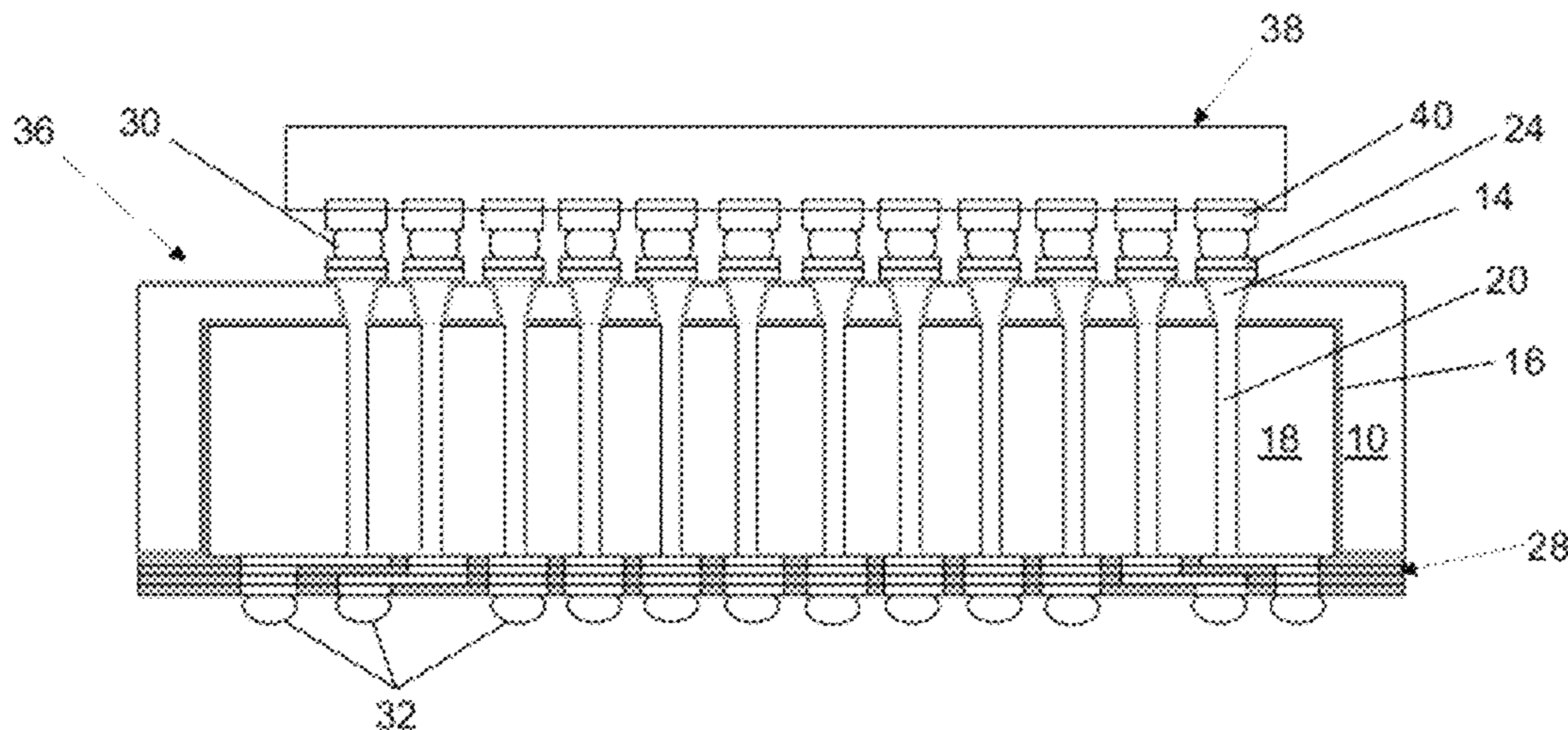

(56)

References Cited

U.S. PATENT DOCUMENTS

2011/0033979	A1	2/2011	Haba
2011/0049696	A1	3/2011	Haba
2011/0187007	A1	8/2011	Haba
2012/0018863	A1	1/2012	Oganesian
2012/0018868	A1	1/2012	Oganesian
2012/0018893	A1	1/2012	Oganesian
2012/0018894	A1	1/2012	Oganesian
2012/0018895	A1	1/2012	Oganesian
2012/0020026	A1	1/2012	Oganesian
2012/0068327	A1	3/2012	Oganesian
2012/0068330	A1	3/2012	Oganesian
2012/0068351	A1	3/2012	Oganesian
2012/0068352	A1	3/2012	Oganesian

OTHER PUBLICATIONS

U.S. Appl. No. 13/157,202, filed Jun. 9, 2011, Oganesian, Vage.
U.S. Appl. No. 13/186,357, filed Jul. 19, 2011 Oganesian, Vage.
U.S. Appl. No. 13/225,092, filed Sep. 2, 2011 Oganesian, Vage.
U.S. Appl. No. 13/301,683, filed Nov. 21, 2011 Oganesian, Vage.
U.S. Appl. No. 13/312,826, filed Dec. 6, 2011 Oganesian, Vage.
U.S. Appl. No. 13/343,682, filed Jan. 4, 2012 Oganesian, Vage.
U.S. Appl. No. 13/427,604, filed Mar. 22, 2012, Oganesian, Vage.
U.S. Appl. No. 13/356,328, filed Jan. 23, 2012, Oganesian, Vage.
U.S. Appl. No. 13/468,632, filed May 10, 2012 Oganesian, Vage.
U.S. Appl. No. 13/559,510, filed Jul. 26, 2012, Oganesian, Vage.
U.S. Appl. No. 13/423,045, filed Mar. 16, 2012, Oganesian, Vage.
U.S. Appl. No. 13/609,002, filed Sep. 10, 2012, Oganesian, Vage.

* cited by examiner

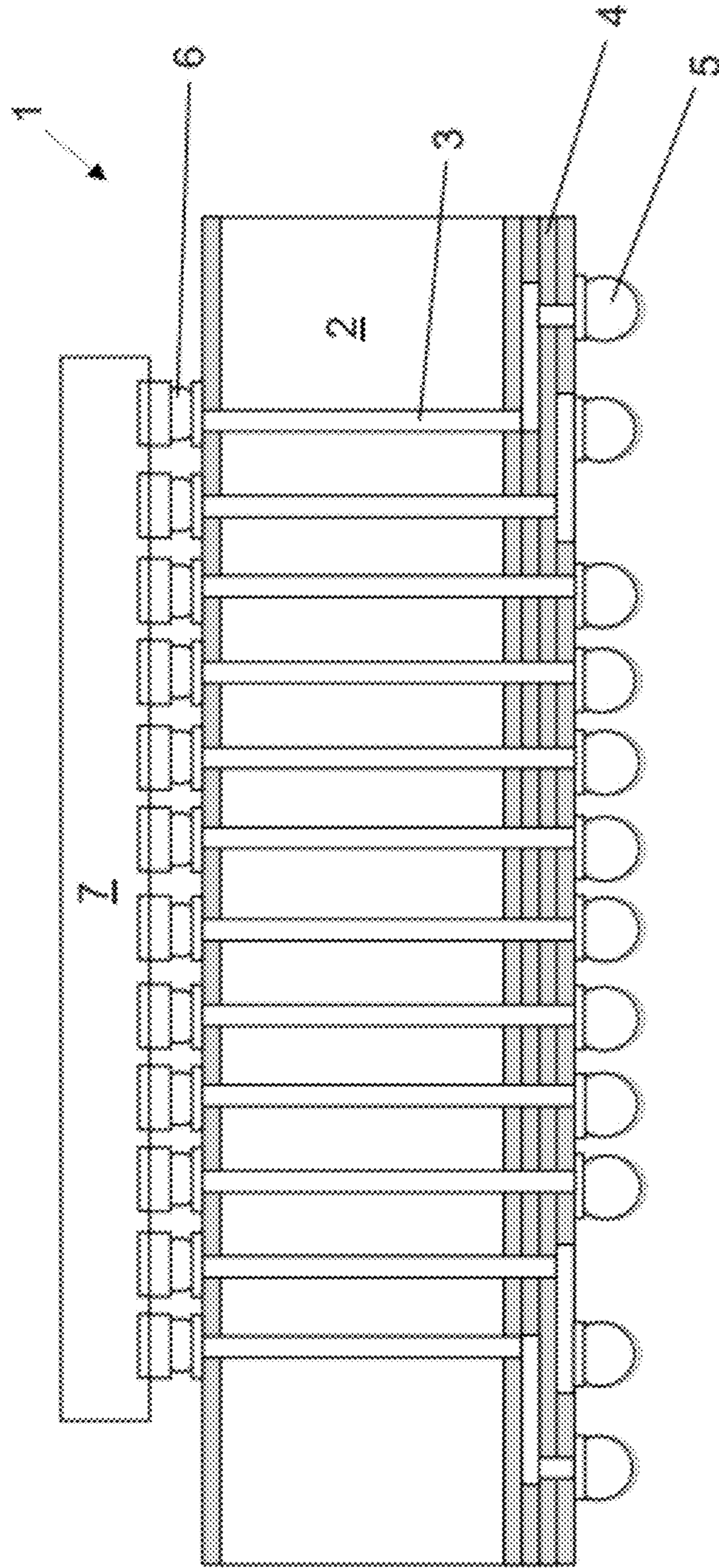

FIG. 1
(Prior Art)

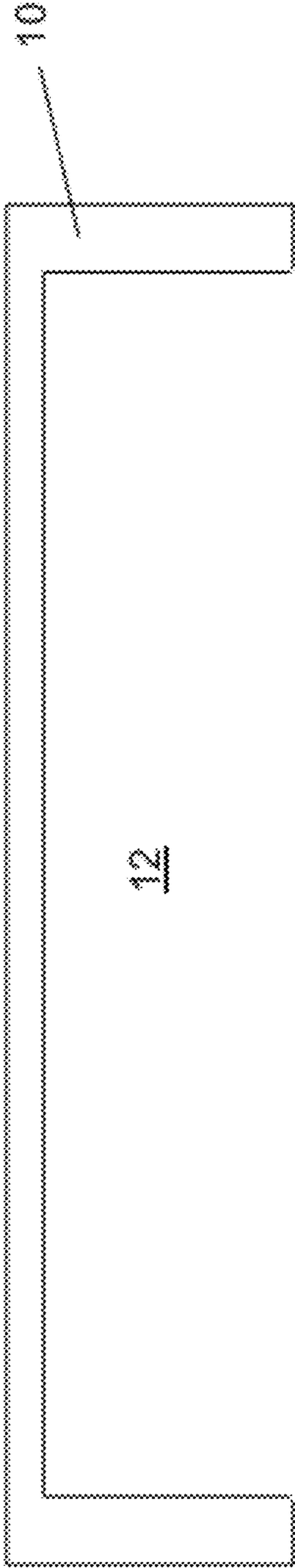

FIG. 2

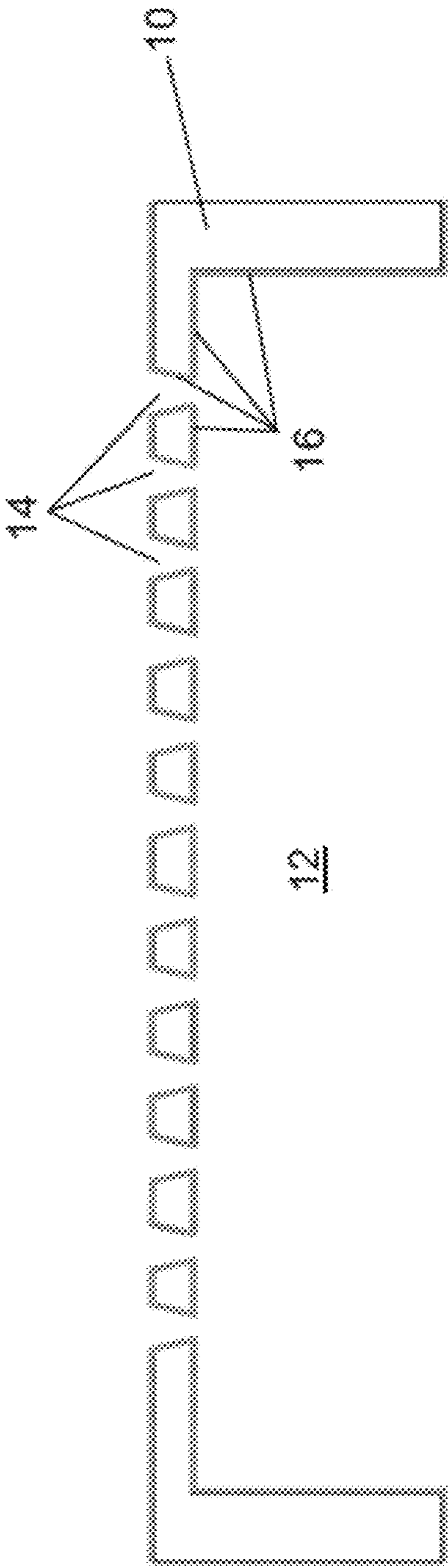

FIG. 3

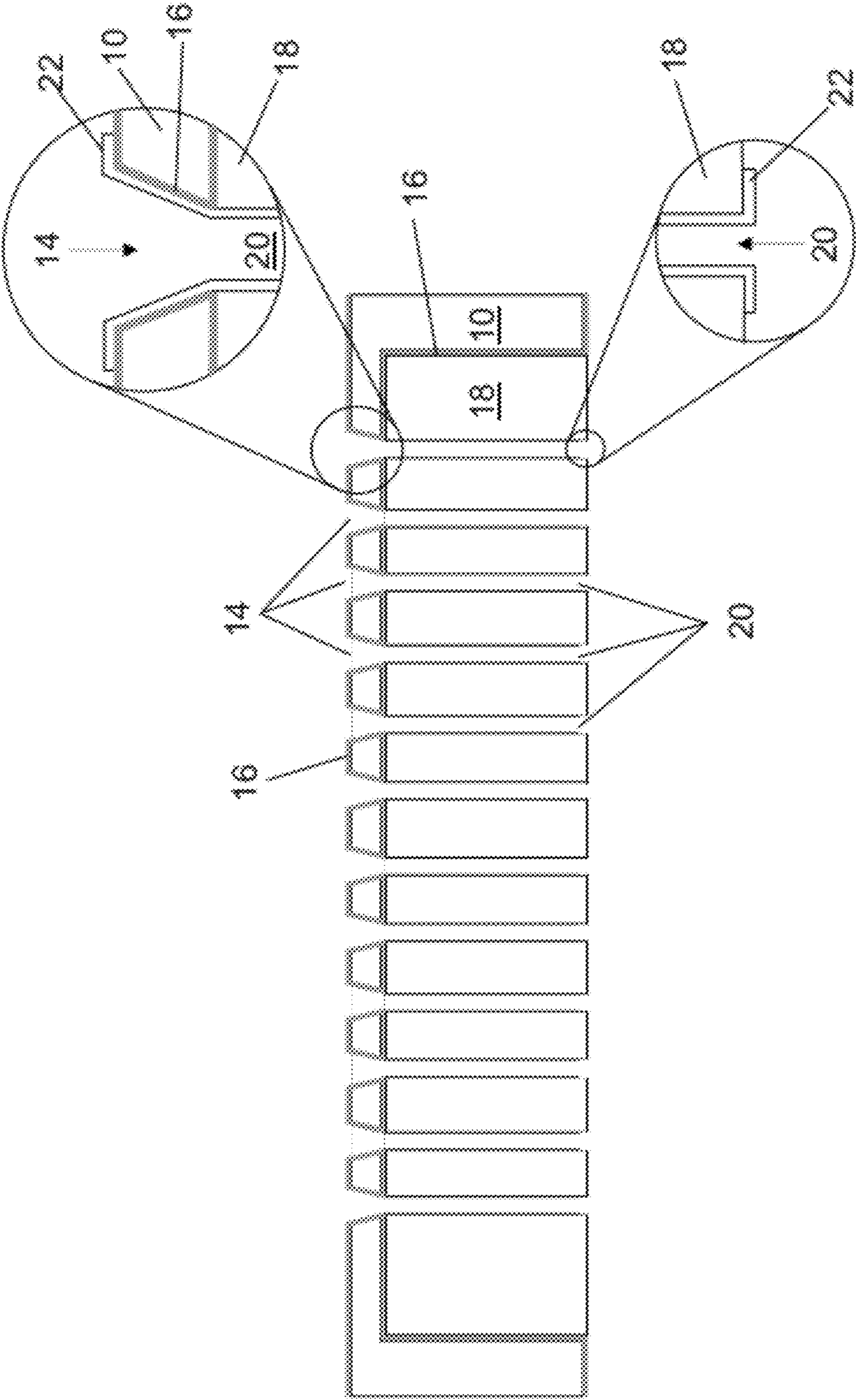
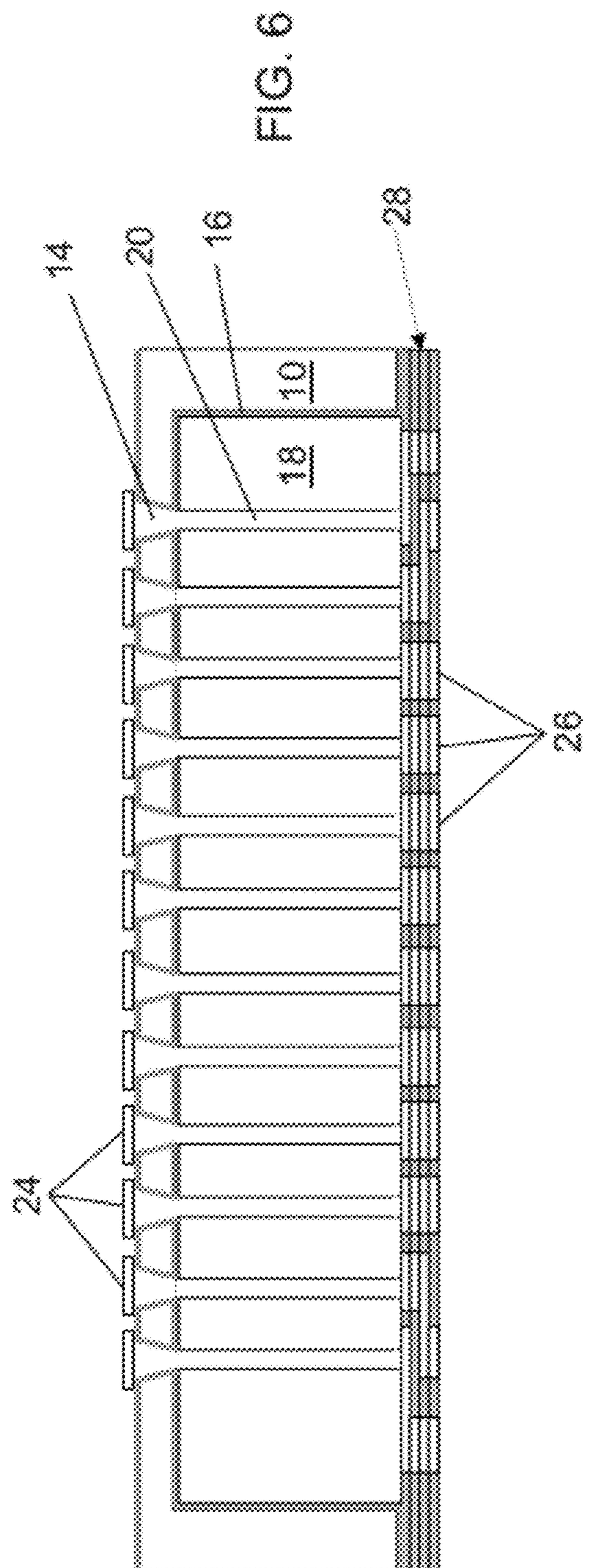
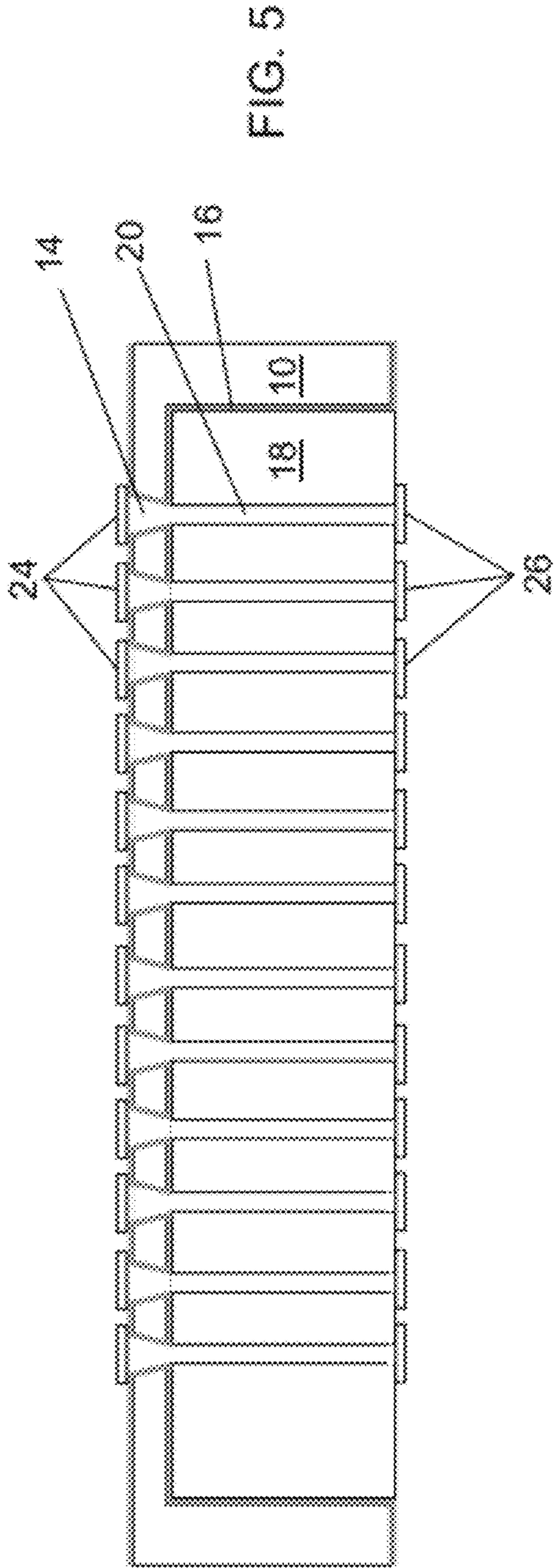

FIG. 4



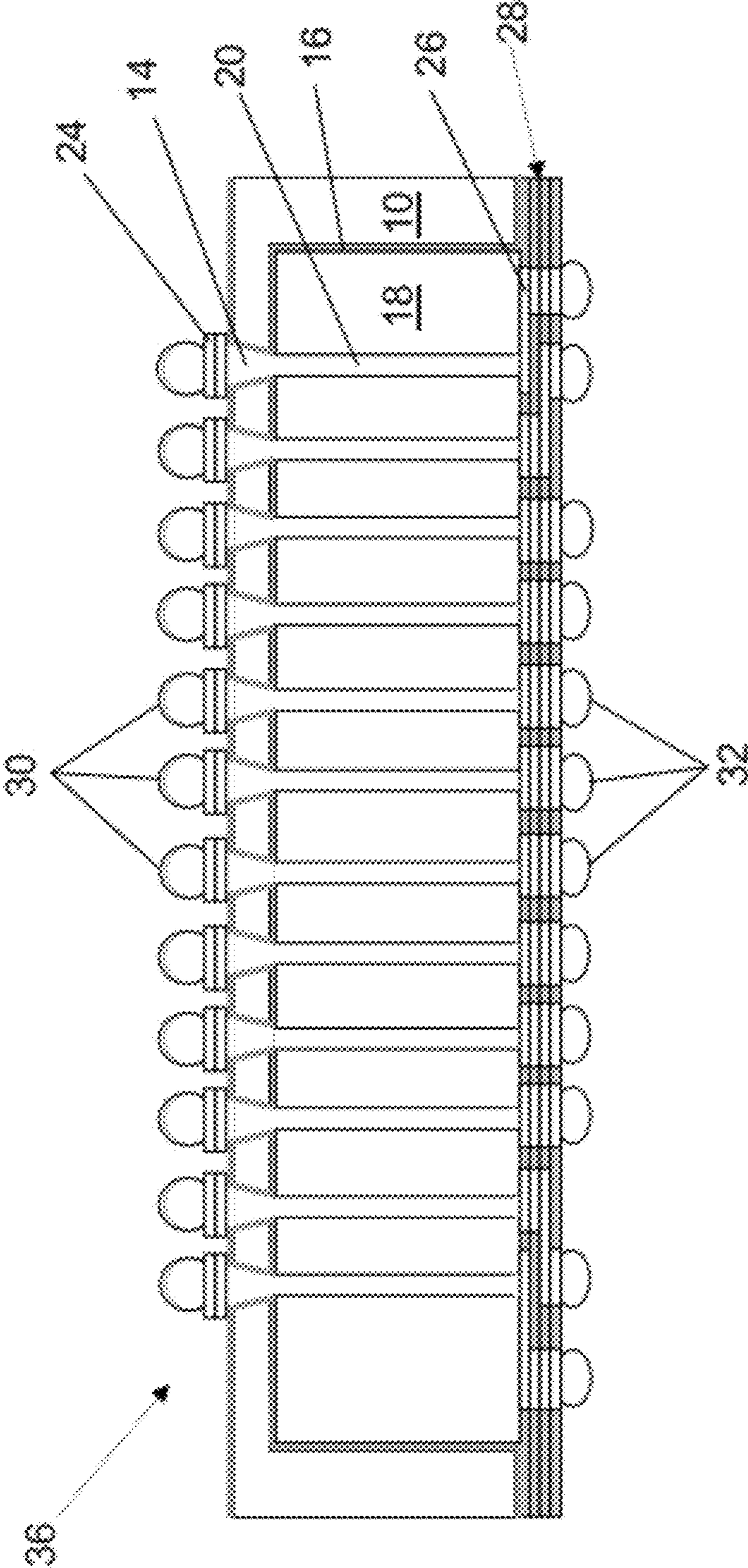

FIG. 7

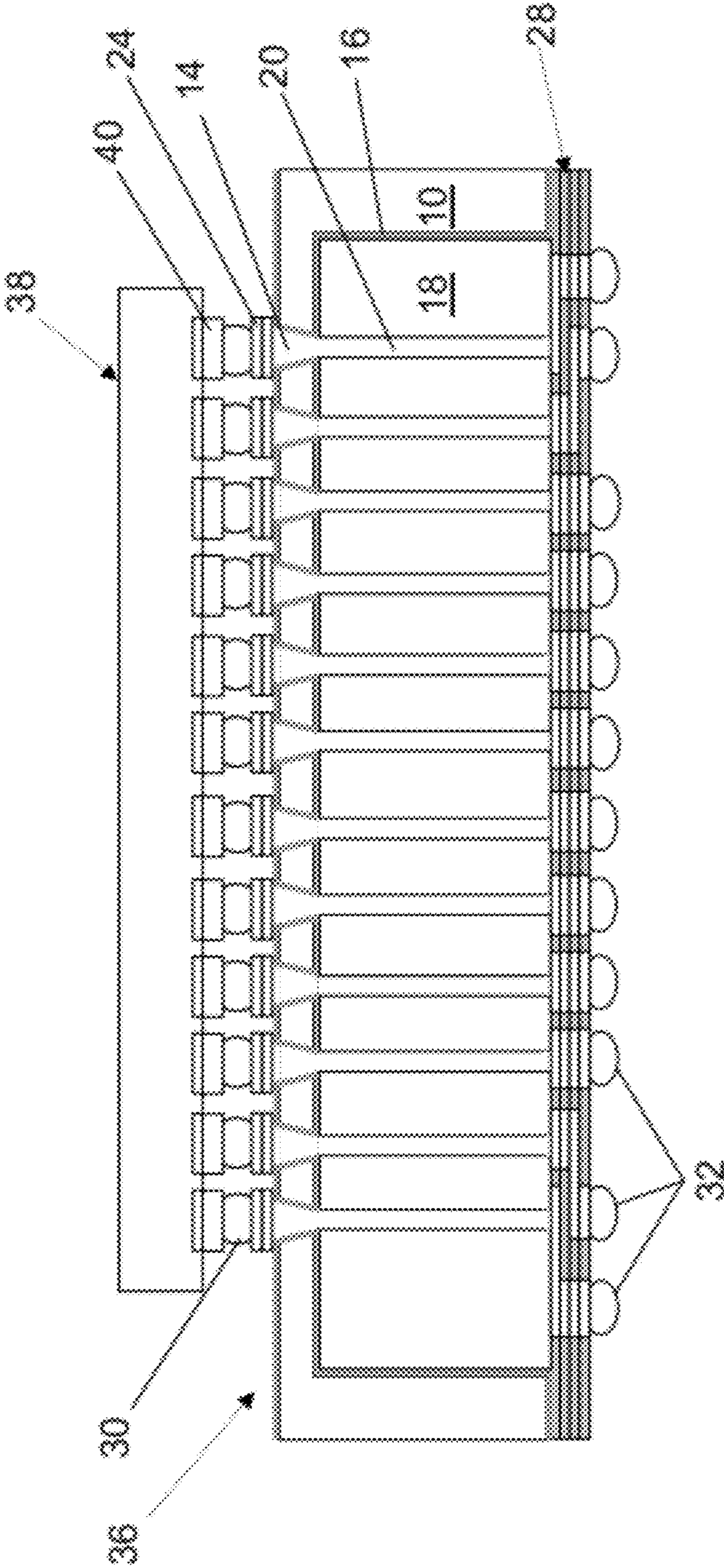

FIG. 8

1**3D INTEGRATION MICROELECTRONIC
ASSEMBLY FOR INTEGRATED CIRCUIT
DEVICES**

FIELD OF THE INVENTION

The present invention relates to semiconductor packaging, and more particularly to a 3D interposer on which a semiconductor device is mounted.

BACKGROUND OF THE INVENTION

The trend for semiconductor devices is smaller integrated circuit devices (IC devices, also referred to as chips), packaged in smaller packages (which protect the chip while providing off chip signaling connectivity). 3D packaging, in which related chips are stacked inside a single package, has recently been developed and refined. 3D packaging can result in increased density and smaller form factor, better electrical performance (because of shorter interconnect length which allows for increased device speed and lower power consumption), better heterogeneous integration (i.e. integrate different functional layers such as an image sensor and its processor), and lower cost. Existing 3D IC packaging techniques used to form through-silicon vias (TSVs), including Via-First, Via-Last and Via-middle processes, utilize semiconductor lithographic processes which are inherently complex and costly. As a result, few companies in the world can afford the billions of dollars in CMOS R&D per year to keep pace.

Another related 3D packaging technology is the interposer. A conventional interposer is an insulation substrate (typically plastic or ceramic) with conductive patterns formed on, in and/or through the substrate to provide an electrical interface for semiconductor devices. Interposers are commonly used for chip assembly techniques employing the flip-chip method of using solder balls to create the electrical connections between the chip and the interposer. The interposer can provide electrical connections having a modified, increased, or decreased connection pattern or density relative to the electrical connection pattern or density on the semiconductor device.

More recently, with the advent of through-silicon vias, 3D silicon and glass interposers have been developed to increase the gap between printed circuit boards and integrated circuits, both in terms of geometries and materials, for use in System-in-Package (SiP), Package-on-package (PoP), flip-chip Ball grid Array (fc-BGA) or more recently fan-out Wafer Level Packaging. 3D interposers combine wafer-level techniques and advantages with 3D routing capabilities (e.g. higher resolution and finer pitches/densities).

A conventional 3D interposer is illustrated in FIG. 1. The interposer **1** includes a silicon substrate **2**, through silicon vias **3** extending through and forming an electrical contact through the substrate **2**, routing layers **4** and SMT compatible contacts **5**, flip chip connectors **6** (on which an IC chip **7** is mounted). One difficulty in manufacturing the interposer **1** involves the vias **3**, which are difficult to fabricate as the width of the substrate **2** increases (e.g. requires expensive semiconductor sputtering tools). Moreover, the SMT contacts **5** between the interposer **1** and the underlying printed circuit board can fail due to thermal stress caused by the different thermal and mechanical characteristics between the interposer and PC board on which the interposer is mounted. A complementary, cost-effective TSV solution is needed to enhance the performance of 3D interposers.

2

BRIEF SUMMARY OF THE INVENTION

The present invention is a 3D interposer and method of making same that addresses the deficiencies of conventional interposers.

The interposer includes a crystalline substrate handler having opposing first and second surfaces wherein a cavity is formed into the first surface, a layer of insulation material disposed on a surface of the handler that defines the cavity, a compliant dielectric material disposed in the cavity, and a plurality of electrical interconnects. Each electrical interconnect includes a first hole formed through the crystalline substrate handler extending from the second surface to the cavity, a second hole formed through the compliant dielectric material so as to extend from and be aligned with the first hole, a layer of insulation material formed along a sidewall of the first hole, and conductive material extending through the first and second holes.

The method of forming the interposer includes forming a cavity in a crystalline substrate handler which has opposing first and second surfaces, wherein the cavity is formed into the first surface of the crystalline substrate handler, forming a plurality of first holes through the crystalline substrate handler extending from the second surface to the cavity, forming a layer of insulation material on a surface of the handler that defines the cavity and on sidewalls of the first holes, forming compliant dielectric material in the cavity, forming second holes through the compliant dielectric material such that each of the second holes extends from and is aligned with one of the first holes, and for each one of the second holes extending from and aligned with one of the first holes, forming conductive material extending through the one first hole and the one second hole.

Other objects and features of the present invention will become apparent by a review of the specification, claims and appended figures.

BRIEF DESCRIPTION OF THE DRAWINGS

FIG. 1 is a cross sectional side view of a conventional interposer.

FIGS. 2-7 are cross sectional side views showing in sequence the steps in the forming the interposer of the present invention.

FIG. 8 is a side cross sectional view of an IC device integrated to the interposer of the present invention.

DETAILED DESCRIPTION OF THE INVENTION

The present invention is 3D interposer, the formation thereof as described below and illustrated in FIGS. 2-7. The formation process begins with a crystalline substrate handler **10** as shown in FIG. 2. A non-limiting example can include a handler of crystalline substrate having a thickness of around 600 μm . A cavity **12** is formed in the handler by the use of a laser, a plasma etching process, a sandblasting process, a mechanical milling process, or any other similar method. Preferably cavity **12** is formed by photo-lithography plasma etching, which includes forming a layer of photo resist on the handler **10**, patterning the photo resist layer to expose a select portion of handler **10**, and then performing a plasma etch process (e.g. using a SF₆ plasma) to remove the exposed portion of the handler **10** to form the cavity **12**. Preferably, the cavity **12** extends no further than $\frac{3}{4}$ of the crystalline substrate thickness, or at least leaves a minimum thickness of around 50 μm . The plasma etch can be anisotropic, tapered, isotropic, or combinations thereof.

Through holes **14** are then formed through the thinned portion of handler **10**, whereby they extend from the cavity **12** to the upper surface, as illustrated in FIG. **3**. Holes **14** can be formed using a laser, a plasma etching process, a combination of plasma and wet etch, a sandblasting process, or any similar method. Preferably, the through holes **14** are formed by plasma etching in a similar manner as the formation of the cavity **12** (except that the holes **14** extend all the way through the thinned portion of the crystalline substrate handler **10**). Plasma silicon etching (e.g. anisotropic, tapered, isotropic, or combinations thereof) allows for various shapes of the hole profile. Preferably, the profile of holes **14** is tapered, with a smaller dimension at the cavity side of the holes **14**, and a larger dimension at the top surface of the handler **10**. Preferably the minimum hole diameter is around 10 μm , and the angles of the walls are between 5° and 45° relative to a direction perpendicular to the surfaces of the crystalline substrate through which the holes **14** are formed, such that the hole has a larger cross-sectional size at its top surface than the surface facing cavity **12**. All exposed surfaces of handler **10** (or at least the surfaces defining cavity **12**, the sidewalls of holes **14** and the top surface of handler **10**) are then coated with a layer **16** of insulation material as shown in FIG. **3** (i.e. applied using a spray process, a PECVD process, an electrochemical deposition process, etc.). In a preferred non-limiting embodiment, insulation material layer **16** can be silicon dioxide (SiO_2), applied using a PECVD process, with a minimum thickness of 100 Angstroms.

The cavity **12** is then filled with a compliant dielectric material **18** as shown in FIG. **4**, using a spin coating process, a spray process, a dispense process, an electrochemical deposition process, a lamination process, or any other similar method. A compliant dielectric is a relatively soft material (e.g. solder mask) that exhibits compliance in all three orthogonal directions, and can accommodate the coefficient of thermal expansion (CTE) mismatch between the crystalline substrate ($\sim 2.6 \text{ ppm}/^\circ \text{C}$) and Cu ($\sim 17 \text{ ppm}/^\circ \text{C}$) interconnect. Compliant dielectric material **18** is preferably a polymer, such as BCB (Benzocyclobutene), solder mask, solder resist, FR4, mold compound, or BT epoxy resin. Through holes **20** are then formed through the dielectric material **18**, and are aligned with holes **14**. Holes **20** can be formed by using a CO_2 laser (e.g. spot size of about 70 μm) for larger sized holes **20**, or a UV laser (e.g. spot size of about 20 μm at a wavelength of 355 nm) for smaller sized holes **20** (e.g. less than 50 μm in diameter). Laser pulse frequencies between 10 and 50 kHz at a pulse length of less than 140 ns can be used. Preferably, through holes **20** have a minimum diameter of 10 μm , and are slanted no more than 15 degrees relative to vertical.

The side walls of the through holes **20** are then metalized (i.e. coated with a metallization layer **22**). The metallization process preferably starts with the desmear process for removing any resin smeared on the interior walls of the through holes **20** (caused by the drilling through dielectric materials such as epoxy, polyimide, cyanate ester resins, etc). The process involves contacting the resin smear with a mixture of gamma-butyrolactone and water to soften the resin smear, followed by treatment with an alkaline permanganate solution to remove the softened resin, and treatment with an aqueous acidic neutralizer to neutralize and remove the permanganate residues. After desmear treatment, the initial conductive metallization layer **22** is formed by electroless copper plating, followed by a photo-lithography etch back so that the metallization layer extends away from the holes **20** along dielectric **18** (at the bottom of holes **20**) and away from the holes **14** along insulation layer **16** (at the top of holes **14**), both

for a short distance (e.g. 25 μm or more). Adhesion is obtained at the plated interface by an anchor effect from the surface roughness. The resulting structure is shown in FIG. **4**.

Metal contacts are then formed at both ends of the hole combinations **14/20** by depositing a layer of metal (e.g. by metal sputtering) over insulation layer **16** (and those portions of metal layers **22** extending from holes **14**), and over dielectric material **18** (and those portions of metal layers **22** extending from holes **20**). The deposition of a photo-imagable resist layer is then performed, followed by a photo lithography step (i.e. UV exposure through a mask and selective resist layer removal), followed by selective metal etching of those portions exposed by the photo resist removal, and photo resist removal. The resulting structure is shown in FIG. **5**, where metal contacts **24** are disposed over holes **14** and in electrical contact with metal layers **22** extending therefrom, and metal contacts **26** are disposed over holes **20** and in electrical contact with metal layers **22** extending therefrom.

The metal contacts **26** can be extended, fanned out, or fanned in by performing a series of alternating insulation and conductive layer formations in combination with photolithography steps to create routing layers **28** that route the electrical contacts **26** to their desired final position on the bottom surface of the interposer, as illustrated in FIG. **6**. These routing layers also encapsulate the compliant dielectric material **18** in cavity **12**. Upon completion of the routing process, the outer metal layer can be plated with Ni and Au. Metal contacts **24** can also be extended upwards with additional metal layers (e.g. copper) formed by metal deposition and lithographic etch. BGA interconnects **30** and **32** are then formed on metal contacts **24** and **26** respectively using a screen printing process of a solder alloy, or by a ball placement process, or by a plating process. BGA (Ball Grid Array) interconnects are rounded conductors for making physical and electrical contact with counterpart conductors, usually formed by soldering or partially melting metallic balls onto bond pads. The resulting structure is the interposer assembly **36** shown in FIG. **7**.

An IC chip **38** can then be integrated (i.e. mechanically attached or mounted) to interposer **36** as illustrated in FIG. **8**, where BGA interconnects **30** contact and make electrical connections with bond pads **40** of the IC chip **38**. Integration can be performed using conventional pick-and-place or die attachment equipment. Preferably this is performed in a heated environment, so that BGA interconnects **30** bond with (and make a secure electrical connection between) both metal contacts **24** and bond pads **40**. With the resulting structure shown in FIG. **8**, each bond pad **40** of the IC chip **38** is electrically connected to at least one of the BGA interconnects **32** on the bottom of the interposer **36** via BGA interconnect **30**, metal contact **24**, metal layer **22** extending through holes **14/20**, and metal contacts **26** (extending through routing layers **28**).

Interposer **36** and the method of its manufacture described above and illustrated in the figures have several advantages. First, holes **14/20** and metal layers **22** therein form electrical interconnects that transfer signals through the interposer, and electrically couple the BGA interconnects **30** to BGA interconnects **32**. Second, forming long holes through the crystalline handler is avoided, instead forming shorter holes **14** through a thinned portion of the handler **10**. Forming longer holes **20** through dielectric **18** is easier and requires less expensive equipment and processing compared to forming longer holes through crystalline silicon which requires expensive silicon etching equipment and processing. Third, the combination of insulation layer **16** and dielectric **18** provides superior electrical insulation. Fourth, mechanical

5

stresses are reduced because the thermal and mechanical characteristics of dielectric material **18** better match that of the PCB to which the interposer **36** will be mounted, as compared to if the interposer was primarily crystalline silicon through its entire thickness. Fifth, dielectric material **18** additionally provides superior mechanical insulation.

It is to be understood that the present invention is not limited to the embodiment(s) described above and illustrated herein, but encompasses any and all variations falling within the scope of the appended claims. For example, references to the present invention herein are not intended to limit the scope of any claim or claim term, but instead merely make reference to one or more features that may be covered by one or more of the claims. Materials, processes and numerical examples described above are exemplary only, and should not be deemed to limit the claims. Further, as is apparent from the claims and specification, not all method steps need be performed in the exact order illustrated or claimed, but rather in any order separately or simultaneously that allows the proper formation of the interposer of the present invention. Single layers of material could be formed as multiple layers of such or similar materials, and vice versa. While the formation of the metal contacts through holes **14/20** is shown and described as a metal layer **22** formed along the sidewalls of holes **14/20**, they can alternately be formed by completely filling the holes **14/20** with metal or other conductive materials. Or, the metal material can be formed along the sidewalls of holes **14** while completely filling holes **20**, or vice versa.

It should be noted that, as used herein, the terms “over” and “on” both inclusively include “directly on” (no intermediate materials, elements or space disposed therebetween) and “indirectly on” (intermediate materials, elements or space disposed therebetween). Likewise, the term “adjacent” includes “directly adjacent” (no intermediate materials, elements or space disposed therebetween) and “indirectly adjacent” (intermediate materials, elements or space disposed there between), “mounted to” includes “directly mounted to” (no intermediate materials, elements or space disposed there between) and “indirectly mounted to” (intermediate materials, elements or spaced disposed there between), and “electrically coupled” includes “directly electrically coupled to” (no intermediate materials or elements there between that electrically connect the elements together) and “indirectly electrically coupled to” (intermediate materials or elements there between that electrically connect the elements together). For example, forming an element “over a substrate” can include forming the element directly on the substrate with no intermediate materials/elements therebetween, as well as forming the element indirectly on the substrate with one or more intermediate materials/elements therebetween.

What is claimed is:

1. An interposer, comprising:

a crystalline substrate handler having opposing first and second surfaces, wherein a cavity is formed into the first surface;

6

a layer of insulation material disposed on a surface of the handler that defines the cavity;
 a compliant dielectric material disposed in the cavity; and
 a plurality of electrical interconnects each comprising:
 a first hole formed through the crystalline substrate handler extending from the second surface to the cavity,
 a second hole formed through the compliant dielectric material so as to extend from and be aligned with the first hole,
 a layer of insulation material formed along a sidewall of the first hole, and
 conductive material extending through the first and second holes.

2. The interposer of claim **1**, wherein the compliant dielectric material includes a polymer.

3. The interposer of claim **1**, wherein for each of the plurality of electrical interconnects, the first hole is tapered such that the first hole has a smaller cross-sectional dimension at the cavity than at the second surface.

4. The interposer of claim **1**, wherein for each of the plurality of electrical interconnects, the sidewall of the first hole extends in a direction between 5° and 45° relative to a direction that is perpendicular to the first and second surfaces.

5. The interposer of claim **1**, wherein the conductive material comprises a layer of metal extending along sidewalls of the first and second holes.

6. The interposer of claim **1**, wherein each of the plurality of electrical interconnects further comprises:

a first metal contact disposed over the first hole, insulated from the second surface, and electrically coupled to the conductive material; and

a second metal contact disposed over the dielectric material and the second hole, and electrically coupled to the conductive material,

wherein the first metal contact is electrically coupled to the second metal contact via the conductive material extending through the first and second holes.

7. The interposer of claim **6**, further comprising:

a first plurality of rounded interconnects each electrically coupled to one of the first metal contacts; and

a second plurality of rounded interconnects each electrically coupled to one of the second metal contacts.

8. The interposer of claim **6**, further comprising:

one or more layers of insulation materials disposed over the first surface and over the compliant dielectric material wherein the one or more layers of insulation materials encapsulates the compliant dielectric material in the cavity, and wherein the second metal contacts extend through the one or more layers of insulation materials.

9. The interposer of claim **6**, further comprising:

an IC device including a plurality of bond pads, wherein the IC device is mounted over the second surface such that the plurality of bond pads are electrically coupled to the first plurality of rounded interconnects.

* * * * *