



US008540525B2

(12) **United States Patent**
Regnier et al.

(10) **Patent No.:** **US 8,540,525 B2**
(45) **Date of Patent:** **Sep. 24, 2013**

(54) **RESONANCE MODIFYING CONNECTOR**

(56) **References Cited**

(75) Inventors: **Kent E. Regnier**, Lombard, IL (US);
Patrick R. Casher, North Aurora, IL (US);
Jerry A. Long, Elgin, IL (US)

(73) Assignee: **Molex Incorporated**, Lisle, IL (US)

(*) Notice: Subject to any disclaimer, the term of this patent is extended or adjusted under 35 U.S.C. 154(b) by 0 days.

(21) Appl. No.: **13/133,436**

(22) PCT Filed: **Dec. 9, 2009**

(86) PCT No.: **PCT/US2009/067333**

§ 371 (c)(1),
(2), (4) Date: **Aug. 26, 2011**

(87) PCT Pub. No.: **WO2010/068671**

PCT Pub. Date: **Jun. 17, 2010**

(65) **Prior Publication Data**

US 2011/0300757 A1 Dec. 8, 2011

Related U.S. Application Data

(60) Provisional application No. 61/122,216, filed on Dec. 12, 2008.

(51) **Int. Cl.**
H01R 12/00 (2006.01)

(52) **U.S. Cl.**
USPC **439/79**

(58) **Field of Classification Search**
USPC 439/626, 79, 680, 76.1, 701, 108,
439/638, 608, 101

See application file for complete search history.

U.S. PATENT DOCUMENTS

2,664,552 A	12/1953	Ericsson et al.
2,849,700 A	8/1958	Perkin
2,858,372 A	10/1958	Kaufman
3,115,379 A	12/1963	McKee
3,286,220 A	11/1966	Marley et al.
3,343,120 A	9/1967	Whiting
3,399,372 A	8/1968	Uberbacher
3,482,201 A	12/1969	Schneck
3,538,486 A	11/1970	Shiesinger
3,587,028 A	6/1971	Uberbacher
3,591,834 A	7/1971	Kolias
3,641,475 A	2/1972	Irish et al.
3,663,925 A	5/1972	Proctor
3,669,054 A	6/1972	Desso et al.

(Continued)

FOREIGN PATENT DOCUMENTS

EP	0 273 683 A2	7/1988
EP	0 635 910 B1	6/2000

(Continued)

OTHER PUBLICATIONS

International Search Report for PCT/US2009/067333.

Primary Examiner — Jean F Duverne

(74) *Attorney, Agent, or Firm* — Stephen L. Sheldon

(57) **ABSTRACT**

A connector assembly is provided that is suitable for modifying the resonant frequency of ground terminals used in conjunction with high data rate signal terminals. Ground terminals may be interconnected with a conductive bridge so as to provide ground terminals with a predetermined maximum effective electrical length. Reducing the effective electrical length of the ground terminal can move the resonance frequencies of the connector outside the operational range of frequencies at which signals will be transmitted.

29 Claims, 41 Drawing Sheets

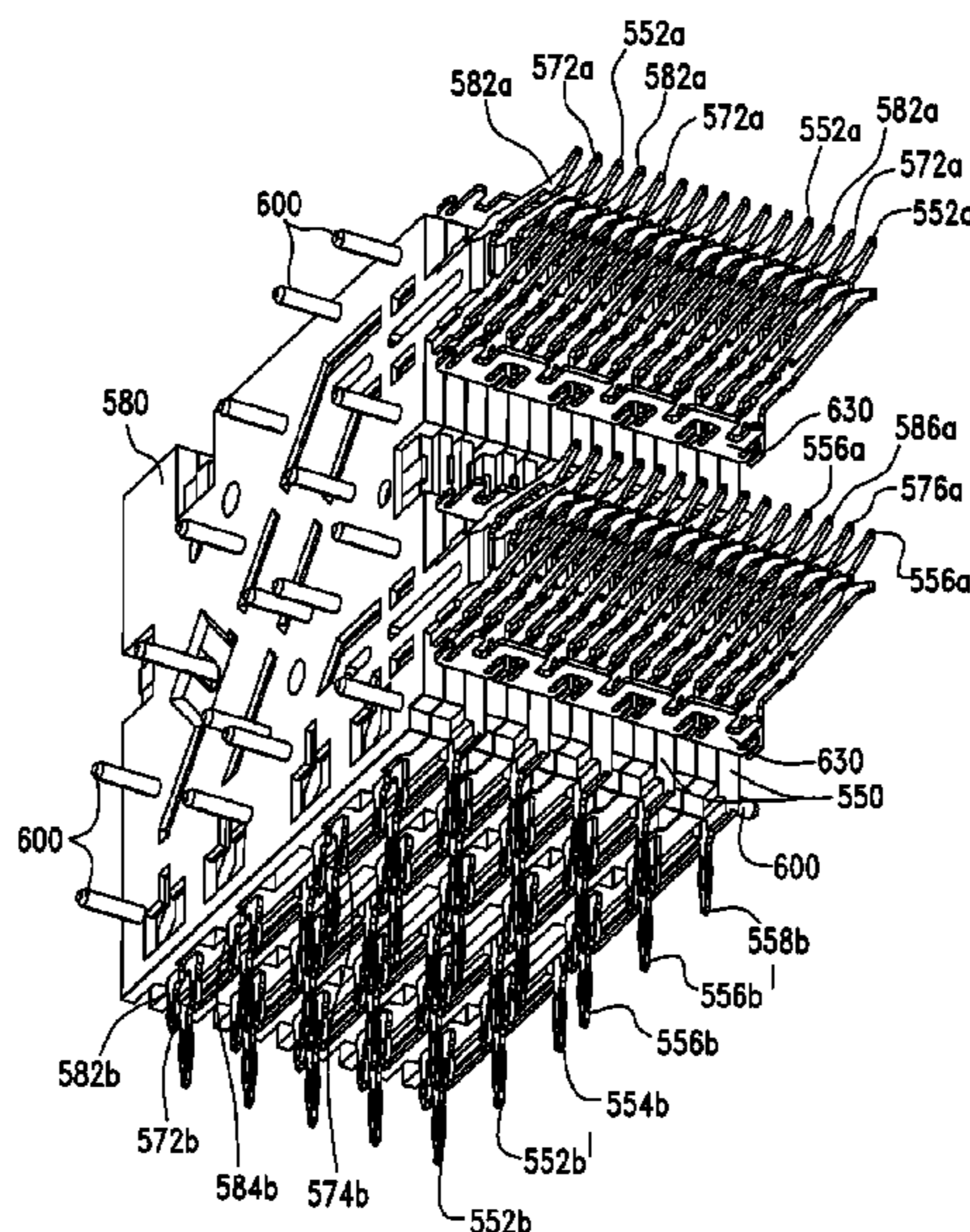

(56)

References Cited

U.S. PATENT DOCUMENTS		
3,701,076	A	10/1972 Irish
3,748,633	A	7/1973 Lundergan
3,827,005	A	7/1974 Friend
3,867,008	A	2/1975 Gartland
4,030,792	A	6/1977 Fuerst
4,076,362	A	2/1978 Ichimura
4,155,059	A	5/1979 Doi
4,157,612	A	6/1979 Rainal
4,159,861	A	7/1979 Anhalt
4,232,924	A	11/1980 Kline et al.
4,260,212	A	4/1981 Ritchie et al.
4,288,139	A	9/1981 Cobaugh et al.
4,383,724	A	5/1983 Verhoeven
4,402,563	A	9/1983 Sinclair
4,407,552	A	10/1983 Watanabe et al.
4,482,937	A	11/1984 Berg
4,523,296	A	6/1985 Healy, Jr.
4,560,222	A	12/1985 Dambach
4,571,014	A	2/1986 Robin et al.
4,664,458	A	5/1987 Worth
4,717,360	A	1/1988 Czaja
4,762,500	A	8/1988 Dola et al.
4,776,803	A	10/1988 Pretchel et al.
4,815,987	A	3/1989 Kawano et al.
4,846,727	A	7/1989 Glover et al.
4,850,887	A	7/1989 Sugawara
4,867,713	A	9/1989 Ozu et al.
4,898,539	A	2/1990 Glover et al.
4,900,271	A	2/1990 Colleran et al.
4,907,990	A	3/1990 Bertho et al.
4,913,664	A	4/1990 Dixon et al.
4,917,616	A	4/1990 Demler, Jr. et al.
4,973,271	A	11/1990 Ishizuka et al.
4,975,066	A	12/1990 Sucheski et al.
4,975,069	A	12/1990 Fedder et al.
4,997,390	A	3/1991 Scholz et al.
5,004,426	A	4/1991 Barnett
5,046,960	A	9/1991 Fedder
5,055,054	A	10/1991 Doutrich
5,065,282	A	11/1991 Polonio
5,066,236	A	11/1991 Broeksteeg
5,077,893	A	1/1992 Mosquera et al.
5,094,623	A	3/1992 Scharf et al.
5,098,311	A	3/1992 Roath et al.
5,127,839	A	7/1992 Korsunsky et al.
5,141,455	A	8/1992 Ponn
5,161,987	A	11/1992 Sinisi
5,163,337	A	11/1992 Herron et al.
5,163,849	A	11/1992 Fogg et al.
5,167,528	A	12/1992 Nishiyama et al.
5,174,770	A	12/1992 Sasaki et al.
5,181,855	A	1/1993 Mosquera et al.
5,228,864	A	7/1993 Fusselman et al.
5,238,414	A	8/1993 Yaegashi et al.
5,254,012	A	10/1993 Wang
5,257,941	A	11/1993 Lwee et al.
5,274,918	A	1/1994 Reed
5,277,624	A	1/1994 Champion et al.
5,286,212	A	2/1994 Broeksteeg
5,288,949	A	2/1994 Crafts
5,302,135	A	4/1994 Lee
5,342,211	A	8/1994 Broeksteeg
5,356,300	A	10/1994 Costello et al.
5,356,301	A	10/1994 Champion et al.
5,357,050	A	10/1994 Baran et al.
5,382,168	A	1/1995 Azuma et al.
5,387,111	A	2/1995 DeSantis et al.
5,395,250	A	3/1995 Englert, Jr. et al.
5,429,520	A	7/1995 Morlion et al.
5,431,578	A	7/1995 Wayne
5,475,922	A	12/1995 Tamura et al.
5,522,727	A	6/1996 Saito et al.
5,558,542	A	9/1996 O'Sullivan et al.
5,575,688	A	11/1996 Crane, Jr.
5,586,908	A	12/1996 Lorrain
5,586,912	A	12/1996 Eslampour et al.
5,586,914	A	12/1996 Foster, Jr. et al.
5,590,463	A	1/1997 Feldman et al.
5,609,502	A	3/1997 Thumma
5,620,340	A	4/1997 Andrews
5,634,821	A	6/1997 Crane, Jr.
5,637,019	A	6/1997 Crane, Jr. et al.
5,672,064	A	9/1997 Provencher et al.
5,697,799	A	12/1997 Consoli et al.
5,713,746	A	2/1998 Olson et al.
5,713,767	A	2/1998 Hanson et al.
5,730,609	A	3/1998 Harwath
5,741,144	A	4/1998 Elco et al.
5,741,161	A	4/1998 Cahaly et al.
5,766,023	A	6/1998 Noschese et al.
5,795,191	A	8/1998 Preputnick et al.
5,817,973	A	10/1998 Elco et al.
5,820,392	A	10/1998 Lin et al.
5,833,475	A	11/1998 Mitra
5,853,797	A	12/1998 Fuchs et al.
5,860,816	A	1/1999 Provencher et al.
5,871,362	A	2/1999 Campbell et al.
5,876,222	A	3/1999 Gardner et al.
5,882,227	A	3/1999 Neidich
5,893,761	A	4/1999 Loungueville
5,902,136	A	5/1999 Lemke et al.
5,904,581	A	5/1999 Pope et al.
5,908,333	A	6/1999 Perino et al.
5,938,479	A	8/1999 Paulson et al.
5,961,355	A	10/1999 Morlion et al.
5,967,844	A	10/1999 Doutrich et al.
5,971,817	A	10/1999 Longueville
5,980,321	A	11/1999 Cohen et al.
5,984,690	A	11/1999 Riechelmann et al.
5,992,953	A	11/1999 Rabinovitz
5,993,259	A	11/1999 Stokoe et al.
6,007,376	A	12/1999 Shimizu
6,022,227	A	2/2000 Huang
6,042,427	A	3/2000 Adriaenssens et al.
6,050,862	A	4/2000 Ishii
6,068,520	A	5/2000 Winings et al.
6,086,386	A	7/2000 Fjelstad et al.
6,116,926	A	9/2000 Ortega et al.
6,116,965	A	9/2000 Arnett et al.
6,123,554	A	9/2000 Ortega et al.
6,125,535	A	10/2000 Chiou et al.
6,129,592	A	10/2000 Mickievicz et al.
6,139,336	A	10/2000 Olson
6,146,157	A	11/2000 Lenoir et al.
6,146,202	A	11/2000 Ramey et al.
6,146,203	A	11/2000 Elco et al.
6,152,747	A	11/2000 McNamara
6,154,742	A	11/2000 Herriot
6,171,115	B1	1/2001 Mickievicz et al.
6,171,149	B1	1/2001 Van Zanten
6,179,663	B1	1/2001 Bradley et al.
6,190,213	B1	2/2001 Reichart et al.
6,212,755	B1	4/2001 Shimada et al.
6,215,076	B1	4/2001 Inagawa et al.
6,219,913	B1	4/2001 Uchiyama
6,220,896	B1	4/2001 Bertoncini et al.
6,227,882	B1	5/2001 Ortega et al.
6,241,535	B1	6/2001 Lemke et al.
6,267,604	B1	7/2001 Mickievicz et al.
6,269,539	B1	8/2001 Takahashi et al.
6,280,209	B1	8/2001 Bassler et al.
6,293,827	B1	9/2001 Stokoe et al.
6,299,483	B1	10/2001 Cohen et al.
6,299,484	B2	10/2001 Van Woensel et al.
6,302,711	B1	10/2001 Ito
6,319,075	B1	11/2001 Clark et al.
6,322,379	B1	11/2001 Ortega et al.
6,322,393	B1	11/2001 Doutrich et al.
6,328,602	B1	12/2001 Yamasaki et al.
6,338,635	B1	1/2002 Lee
6,343,955	B2	2/2002 Billman et al.
6,347,952	B1	2/2002 Hasegawa et al.
6,350,134	B1	2/2002 Fogg et al.
6,354,877	B1	3/2002 Shuey et al.

US 8,540,525 B2

6,358,061 B1	3/2002	Regnier	6,918,776 B2	7/2005	Spink, Jr.
6,361,366 B1	3/2002	Shuey et al.	6,918,789 B2	7/2005	Lang et al.
6,363,607 B1	4/2002	Chen et al.	6,932,649 B1	8/2005	Rothermel et al.
6,364,710 B1	4/2002	Billman et al.	6,939,173 B1	9/2005	Elco et al.
6,371,773 B1	4/2002	Crofoot et al.	6,945,796 B2	9/2005	Bassler et al.
6,375,478 B1	4/2002	Kikuchi	6,951,466 B2	10/2005	Sandoval et al.
6,379,188 B1	4/2002	Cohen et al.	6,953,351 B2	10/2005	Fromm et al.
6,386,914 B1	5/2002	Collins et al.	6,960,103 B2	11/2005	Tokunaga
6,390,826 B1	5/2002	Affolter et al.	6,969,280 B2	11/2005	Chien et al.
6,409,543 B1	6/2002	Astbury, Jr. et al.	6,976,886 B2	12/2005	Winings et al.
6,414,248 B1	7/2002	Sundstrom	6,979,215 B2	12/2005	Avery et al.
6,420,778 B1	7/2002	Sinyansky	6,994,569 B2 *	2/2006	Minich et al. 439/79
6,431,914 B1	8/2002	Billman	7,001,188 B2	2/2006	Kobayashi
6,435,914 B1	8/2002	Billman	7,021,975 B2	4/2006	Lappohn
6,457,983 B1	10/2002	Bassler et al.	7,040,901 B2	5/2006	Benham et al.
6,461,202 B2	10/2002	Kline	7,044,794 B2	5/2006	Consoli et al.
6,464,529 B1	10/2002	Jensen et al.	7,090,501 B1	8/2006	Scherer et al.
6,471,548 B2	10/2002	Bertoncini et al.	7,094,102 B2	8/2006	Cohen et al.
6,482,038 B2	11/2002	Olson	7,097,506 B2	8/2006	Nakada
6,485,330 B1	11/2002	Doutrich	7,101,191 B2	9/2006	Benham
6,494,734 B1	12/2002	Shuey	7,108,556 B2	9/2006	Cohen et al.
6,503,103 B1	1/2003	Cohen et al.	7,114,964 B2	10/2006	Winings et al.
6,506,076 B2	1/2003	Cohen et al.	7,118,391 B2	10/2006	Minich et al.
6,506,081 B2	1/2003	Blanchfield et al.	7,131,870 B2	11/2006	Whiteman et al.
6,520,803 B1	2/2003	Dunn	7,137,832 B2	11/2006	Mongold et al.
6,526,519 B1	2/2003	Cuthbert	7,139,176 B2	11/2006	Taniguchi et al.
6,527,587 B1	3/2003	Ortega et al.	7,153,162 B2	12/2006	Mizumura et al.
6,537,086 B1	3/2003	MacMullin	7,172,461 B2	2/2007	Davis et al.
6,537,087 B2	3/2003	McNamara et al.	7,175,446 B2	2/2007	Bright et al.
6,537,111 B2	3/2003	Brammer et al.	7,179,108 B2	2/2007	Goodman et al.
6,540,522 B2	4/2003	Sipe	7,186,123 B2	3/2007	Lemke et al.
6,540,558 B1	4/2003	Paagman	7,207,807 B2	4/2007	Fogg
6,540,559 B1	4/2003	Kemmick et al.	7,241,168 B2	7/2007	Sakurai et al.
6,547,066 B2	4/2003	Koch	7,278,856 B2	10/2007	Minich
6,551,140 B2	4/2003	Billman et al.	7,281,950 B2	10/2007	Belopolsky
6,554,647 B1	4/2003	Cohen et al.	7,285,018 B2	10/2007	Kenny et al.
6,561,849 B2	5/2003	Naito et al.	7,309,239 B2	12/2007	Shuey et al.
6,565,388 B1	5/2003	Van Woessel et al.	7,310,875 B2	12/2007	Evans
6,572,409 B2	6/2003	Nitta et al.	7,331,802 B2	2/2008	Rothermel et al.
6,572,410 B1	6/2003	Volstorf et al.	7,331,830 B2	2/2008	Minich
6,589,071 B1	7/2003	Lias et al.	7,335,063 B2	2/2008	Cohen et al.
6,592,381 B2	7/2003	Cohen et al.	7,371,117 B2	5/2008	Gailus
6,607,402 B2	8/2003	Cohen et al.	7,396,259 B2	7/2008	Marshall
6,623,310 B1 *	9/2003	Billman et al. 439/701	7,431,616 B2	10/2008	Minich
6,633,490 B2	10/2003	Centola et al.	7,467,955 B2	12/2008	Raistrick et al.
6,638,079 B1 *	10/2003	Billman et al. 439/76.1	7,497,736 B2	3/2009	Minich et al.
6,641,411 B1	11/2003	Stoddard et al.	7,524,209 B2	4/2009	Hull et al.
6,641,825 B2	11/2003	Scholz et al.	7,534,142 B2	5/2009	Avery et al.
6,648,657 B1	11/2003	Korsunsky et al.	7,758,385 B2 *	7/2010	Davis et al. 439/626
6,652,318 B1	11/2003	Winings et al.	7,762,843 B2	7/2010	Minich et al.
6,659,808 B2	12/2003	Billman et al.	7,837,504 B2	11/2010	Hull et al.
6,672,907 B2	1/2004	Azuma	7,862,347 B2 *	1/2011	Amleshi et al. 439/82
6,692,272 B2	2/2004	Lemke et al.	7,972,151 B2	7/2011	He et al.
6,695,627 B2	2/2004	Ortega et al.	8,096,832 B2	1/2012	Minich et al.
6,717,825 B2	4/2004	Volstorf	8,137,127 B2	3/2012	Hunkins et al.
6,736,664 B2	5/2004	Ueda et al.	2003/0181077 A1	9/2003	Rothermel et al.
6,746,278 B2	6/2004	Nelson et al.	2004/0157477 A1	8/2004	Johnson et al.
6,749,439 B1	6/2004	Potter et al.	2004/0224559 A1	11/2004	Nelson et al.
6,762,067 B1	7/2004	Quinones et al.	2005/0170700 A1	8/2005	Shuey et al.
6,764,341 B2	7/2004	Lappoehn	2005/0196987 A1	9/2005	Shuey et al.
6,776,649 B2	8/2004	Pape et al.	2005/0227552 A1	10/2005	Yamashita et al.
6,786,771 B2	9/2004	Gailus	2006/0003628 A1	1/2006	Long et al.
6,805,278 B1	10/2004	Olson et al.	2006/0073709 A1	4/2006	Reid
6,808,399 B2	10/2004	Rothermel et al.	2006/0094292 A1	5/2006	Shindo
6,808,420 B2	10/2004	Whiteman et al.	2006/0189212 A1	8/2006	Avery et al.
6,824,391 B2	11/2004	Mickievicz et al.	2006/0192274 A1	8/2006	Lee et al.
6,835,072 B2	12/2004	Simons et al.	2006/0228912 A1	10/2006	Morlion et al.
6,843,686 B2	1/2005	Ohnishi et al.	2006/0232301 A1	10/2006	Morlion et al.
6,848,944 B2	2/2005	Evans	2008/0026608 A1	1/2008	Sano et al.
6,851,974 B2	2/2005	Doutrich	2008/0096433 A1	4/2008	Bixler et al.
6,851,980 B2	2/2005	Nelson et al.	2008/0233800 A1	9/2008	Cai et al.
6,869,292 B2	3/2005	Johnescu et al.			
6,884,117 B2	4/2005	Korsunsky et al.			
6,890,214 B2	5/2005	Brown et al.			
6,893,300 B2	5/2005	Zhou et al.			
6,893,686 B2	5/2005	Egan			
6,899,566 B2	5/2005	Kline et al.			
6,902,411 B2	6/2005	Kubo			
6,913,490 B2	7/2005	Whiteman et al.			

FOREIGN PATENT DOCUMENTS

EP	0 891 016 B1	10/2002
EP	1 148 587 B1	4/2005
JP	06-236788	8/1994
JP	07-114958	5/1995

US 8,540,525 B2

Page 4

JP	11-185886	7/1999	WO	WO 02/101882 A2	12/2002
JP	2000-003743	1/2000	WO	WO 2004/030158 A2	4/2004
JP	2000-003744	1/2000	WO	WO 2006/031296 A2	3/2006
JP	2000-003745	1/2000	WO	WO 2006/105535 A1	10/2006
JP	2000-003746	1/2000	WO	WO 2009/111283 A2	9/2009
WO	WO 90/16093 A1	12/1990			
WO	WO 01/29931 A1	4/2001			
WO	WO 01/39332 A1	5/2001			

* cited by examiner

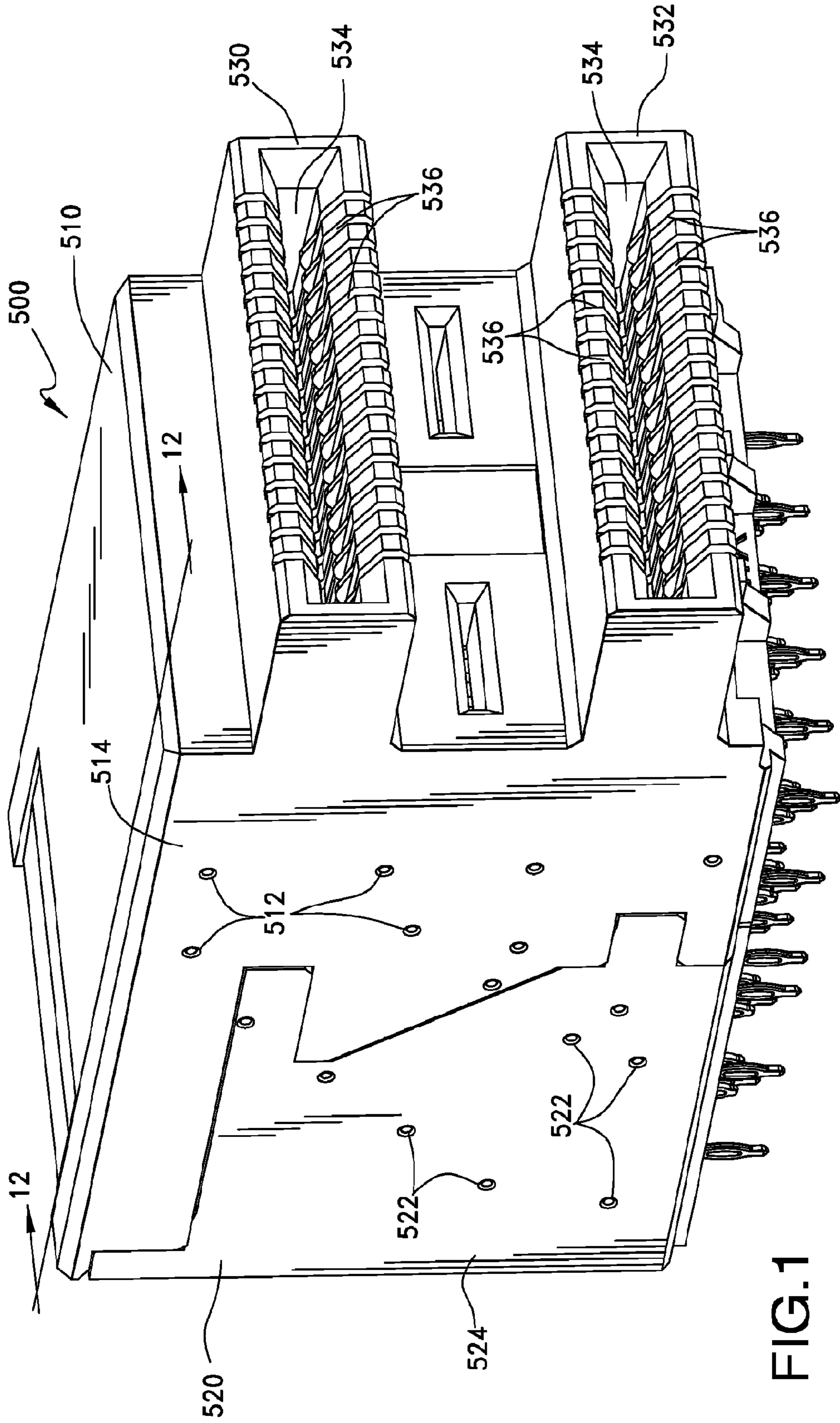

FIG. 1

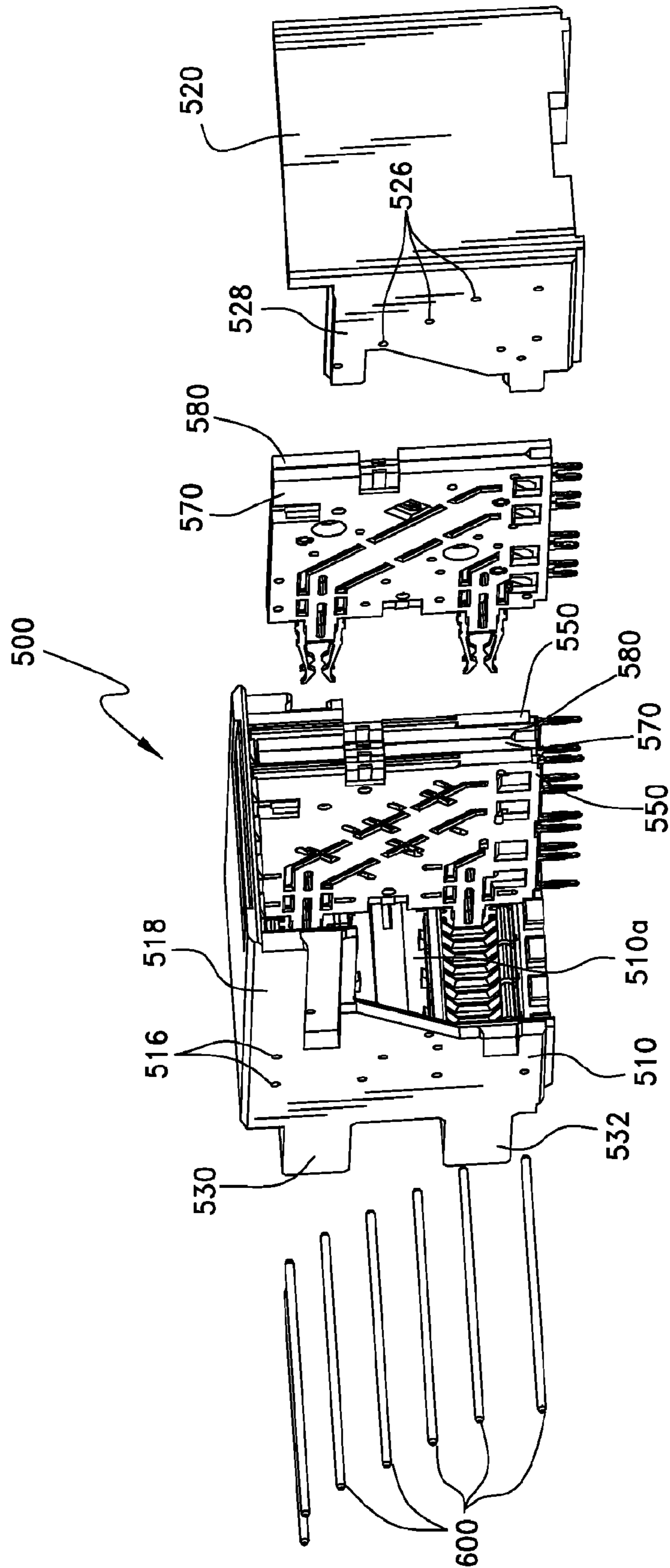

FIG.2

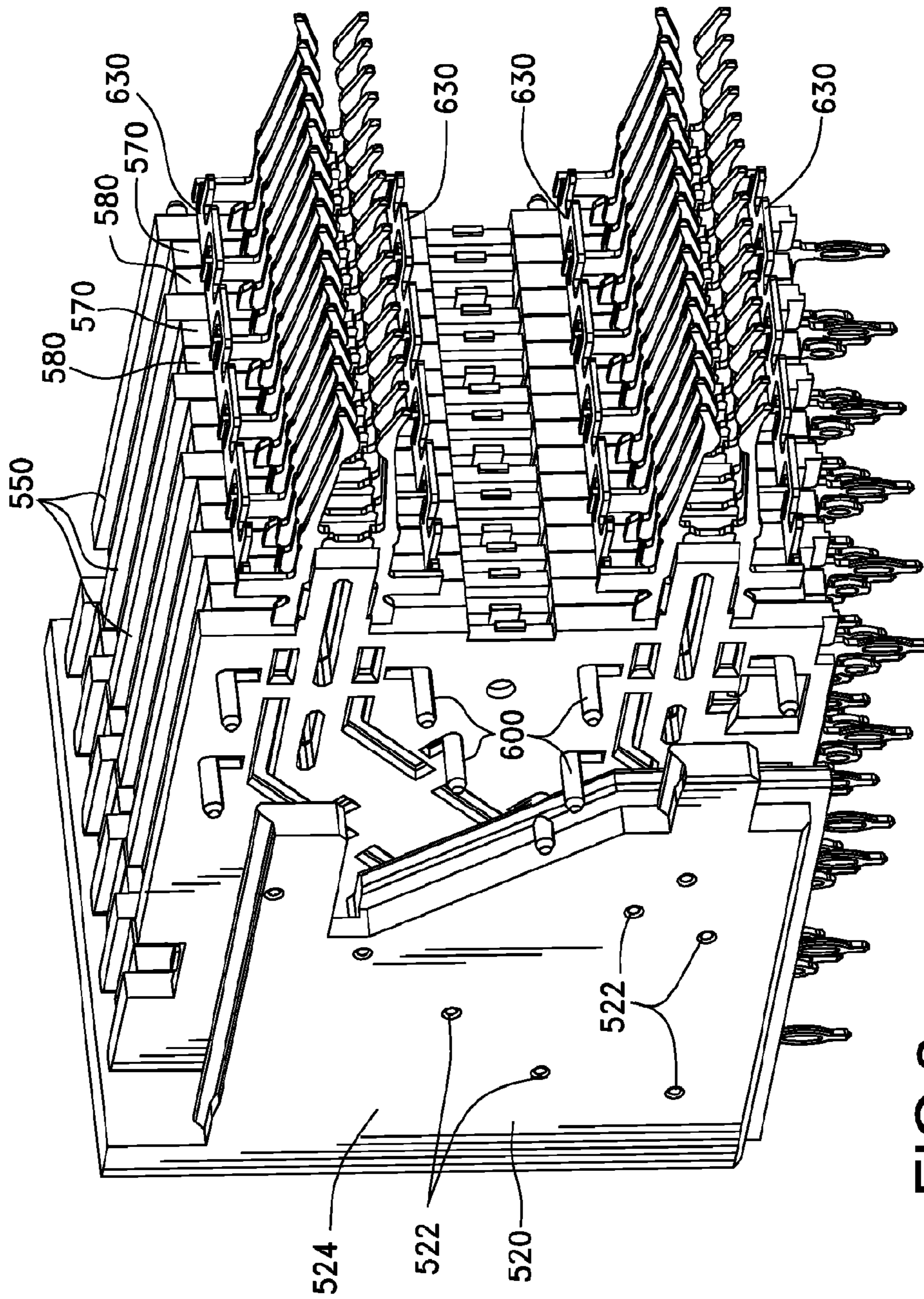

FIG. 3

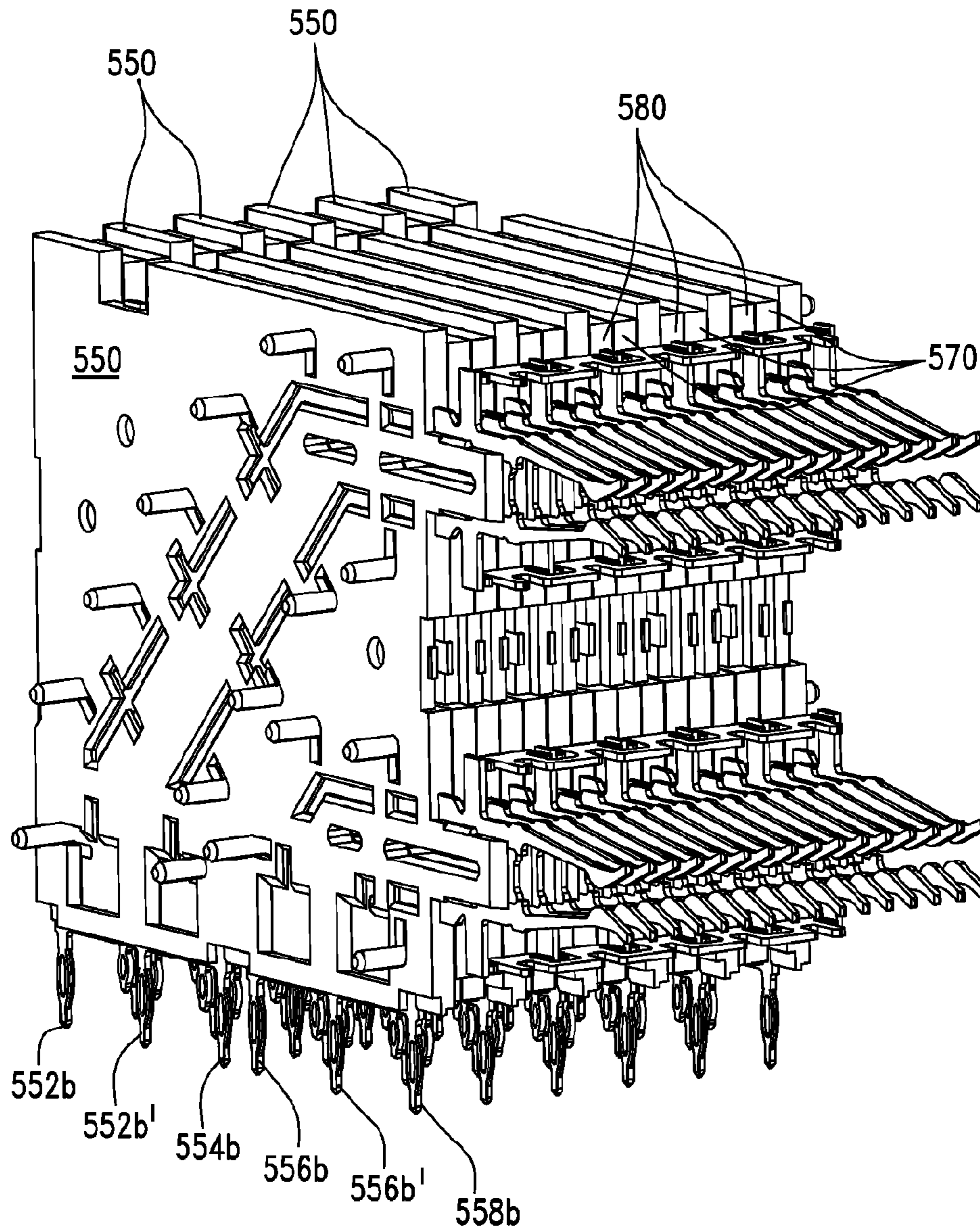

FIG.4

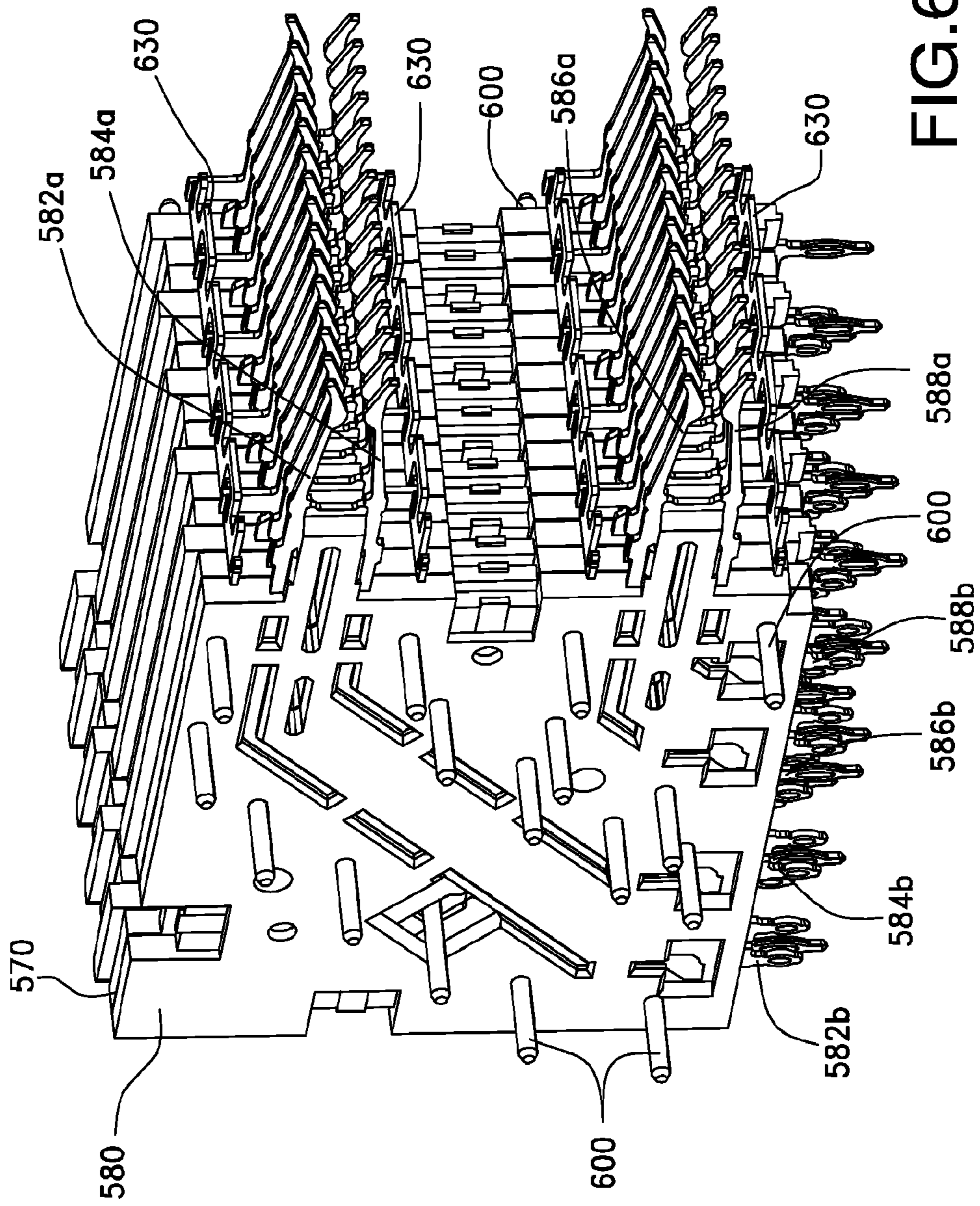

FIG. 6

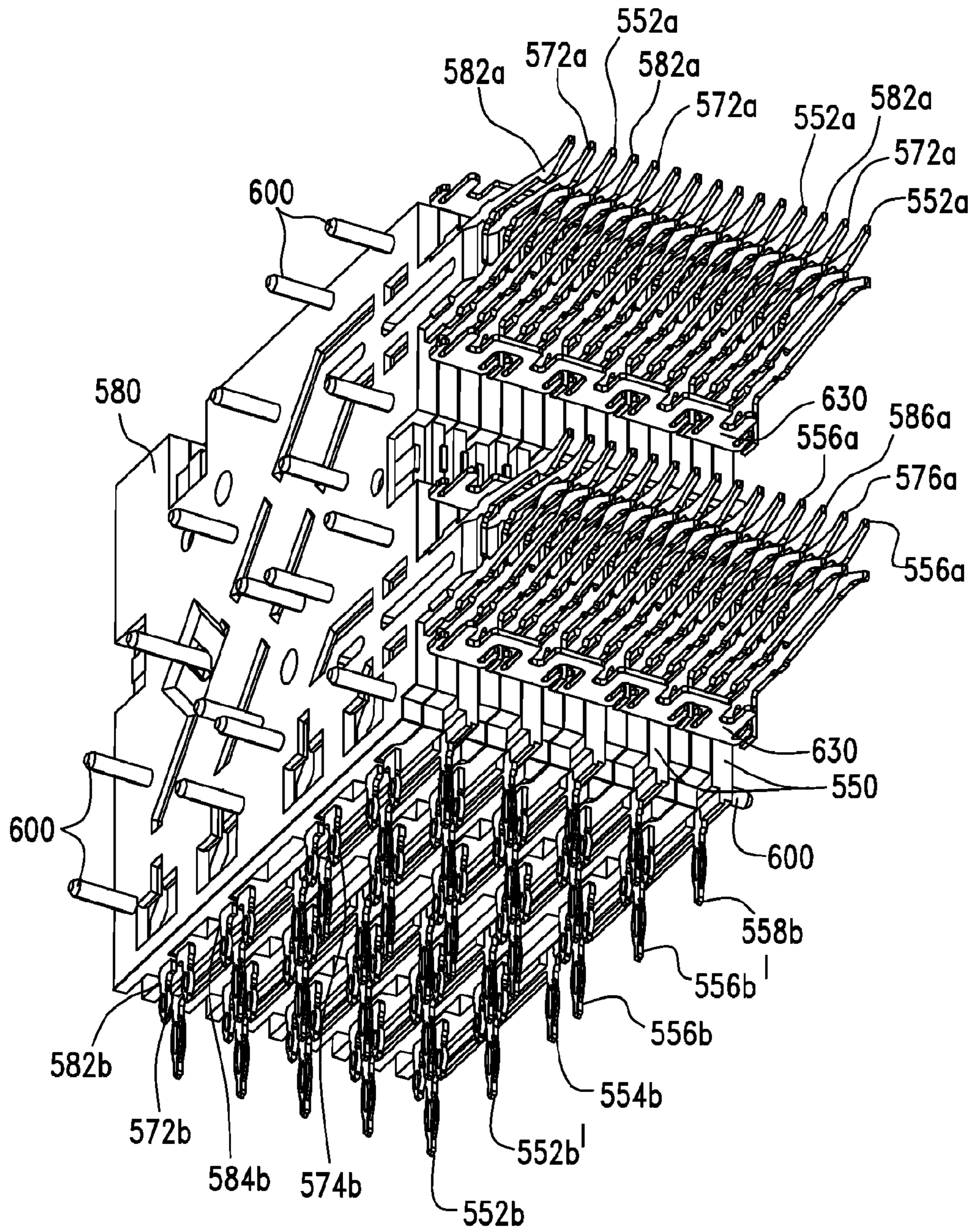

FIG.7

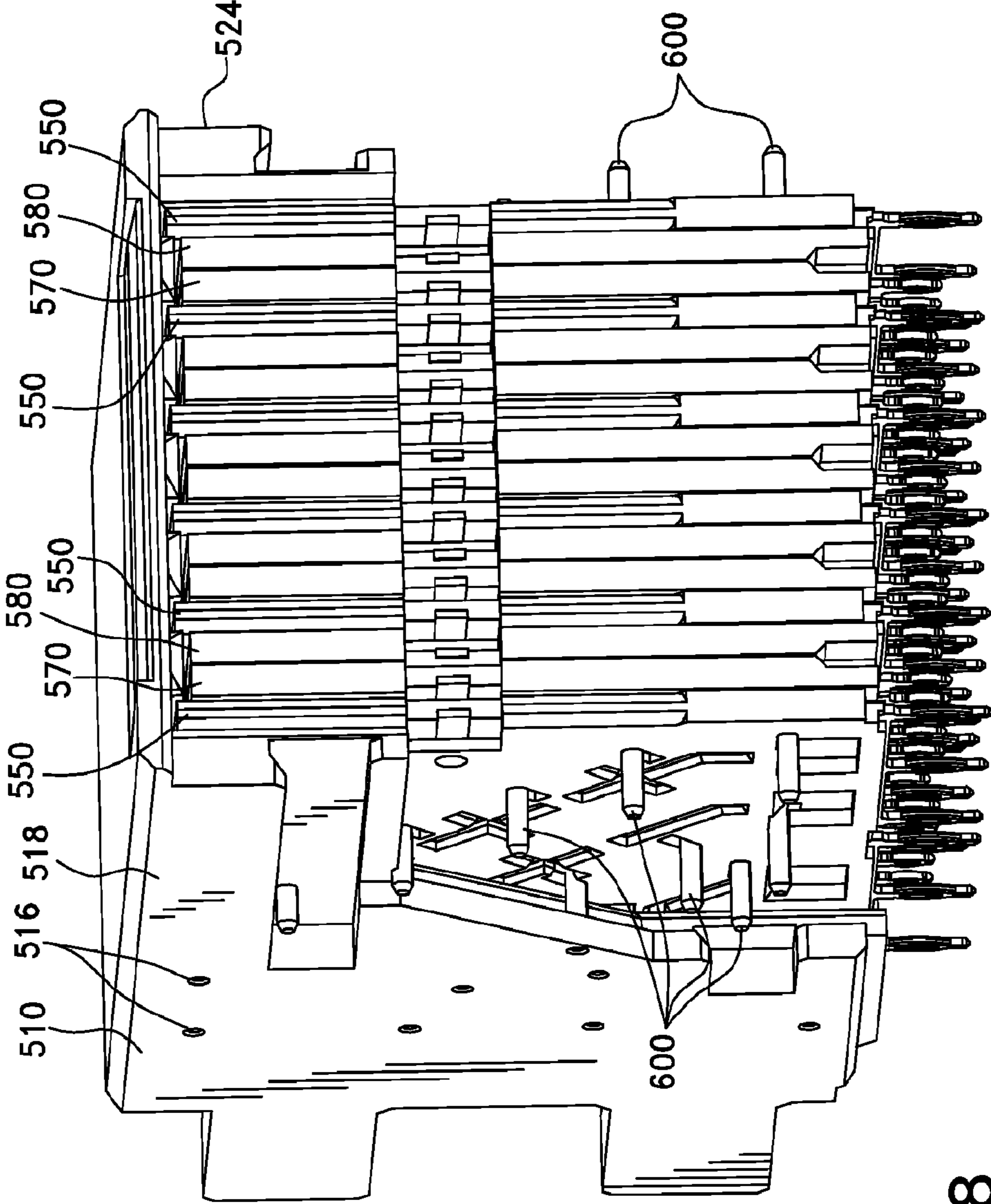

FIG.8

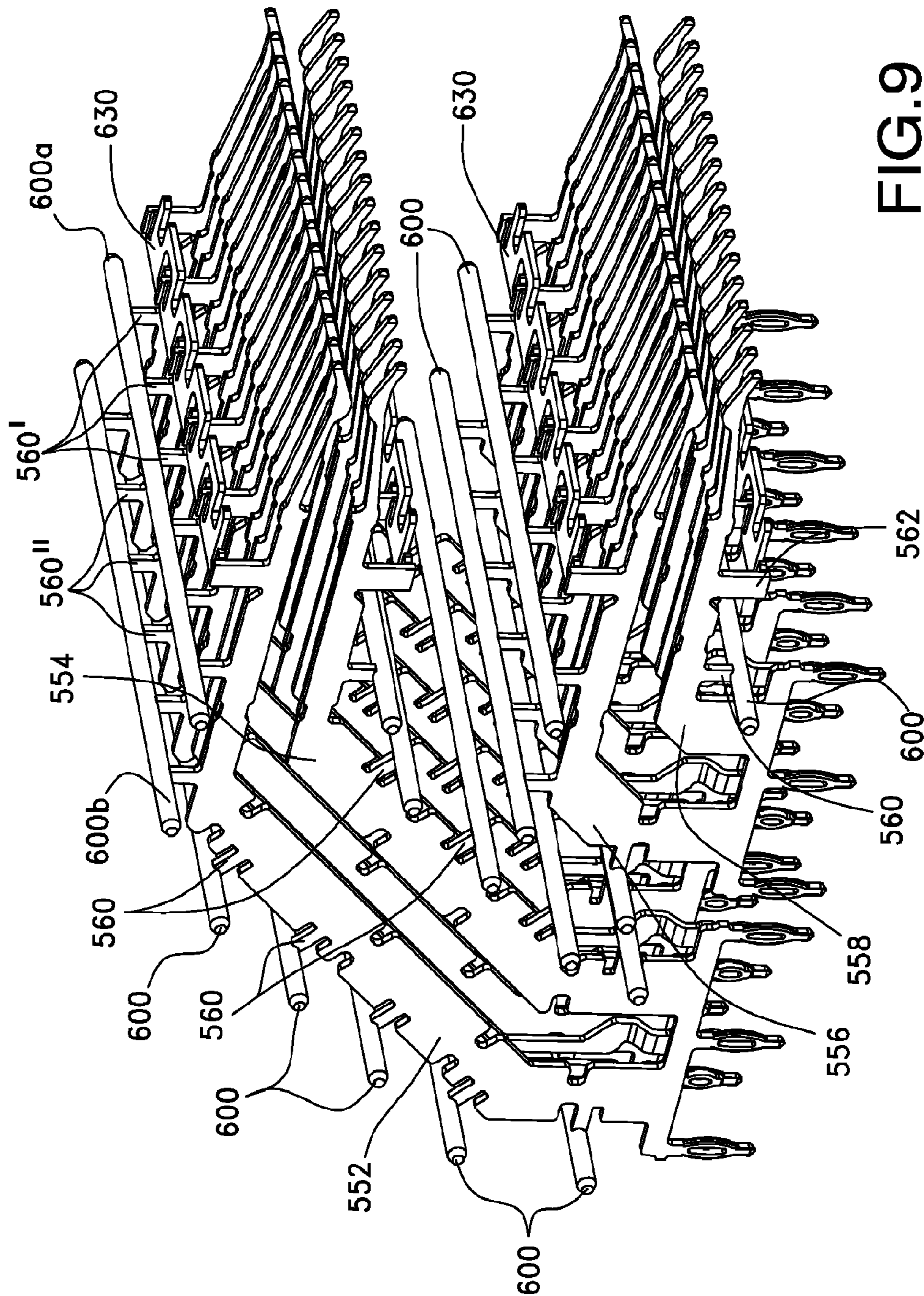

FIG. 9

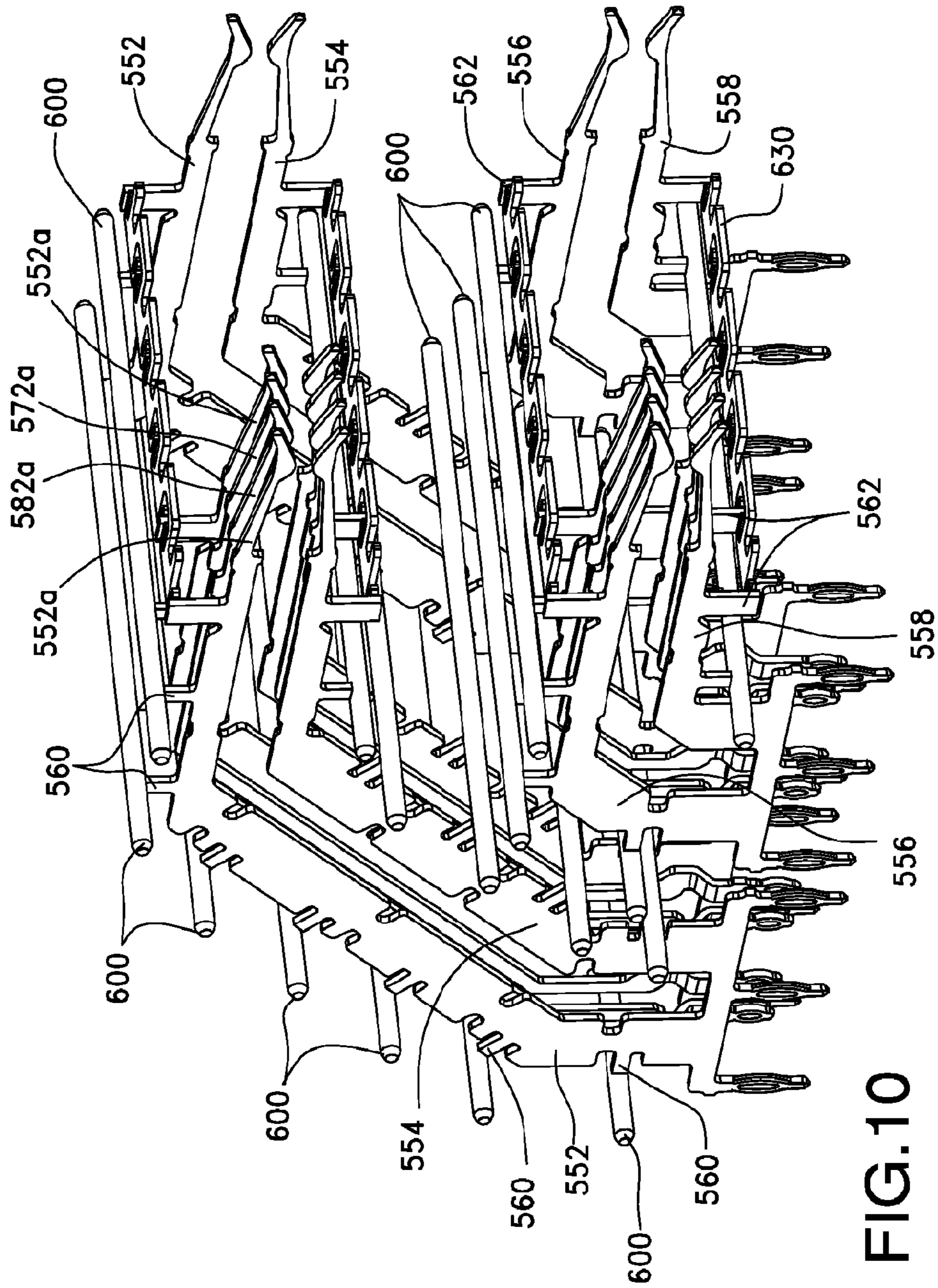

FIG.10

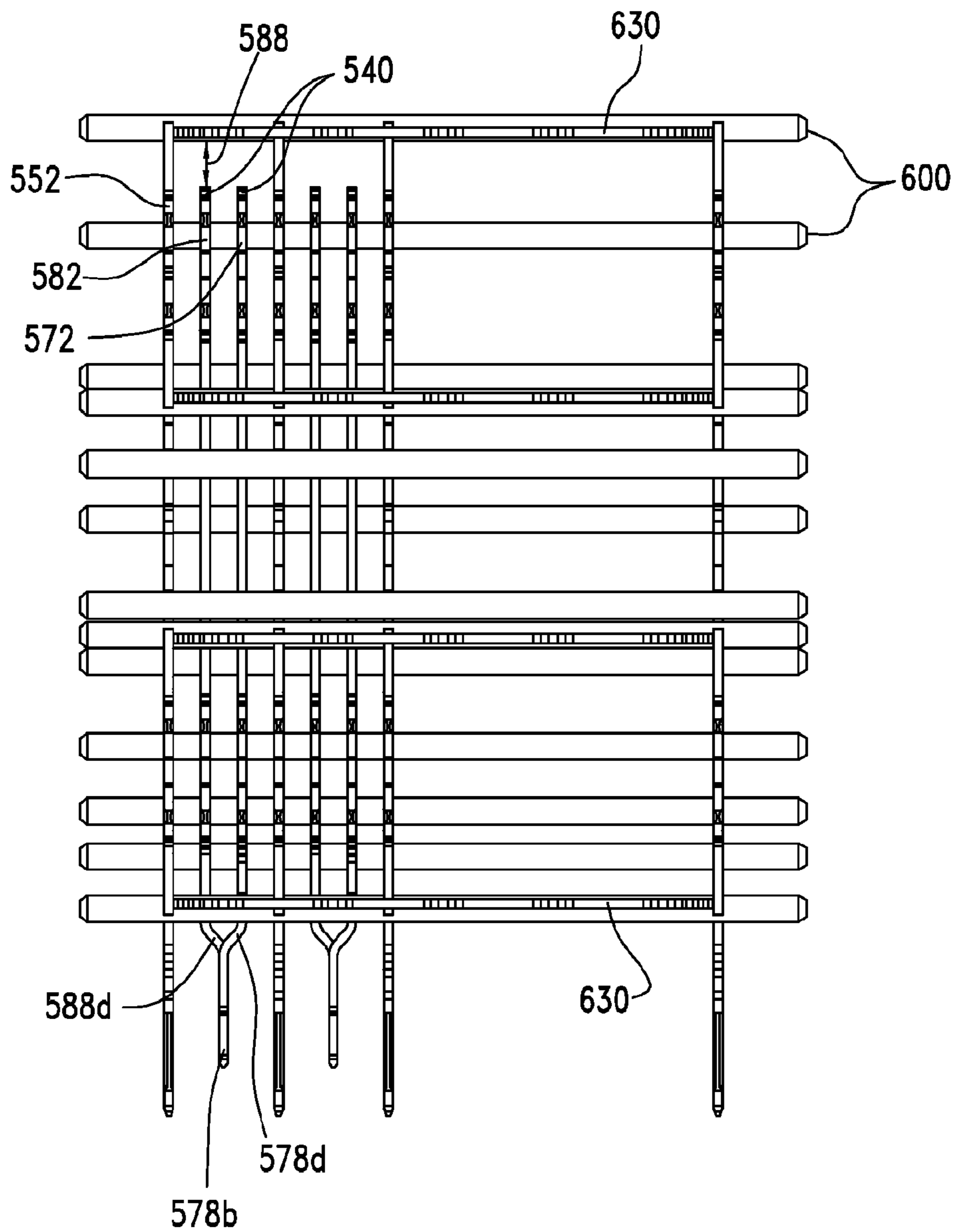

FIG.11

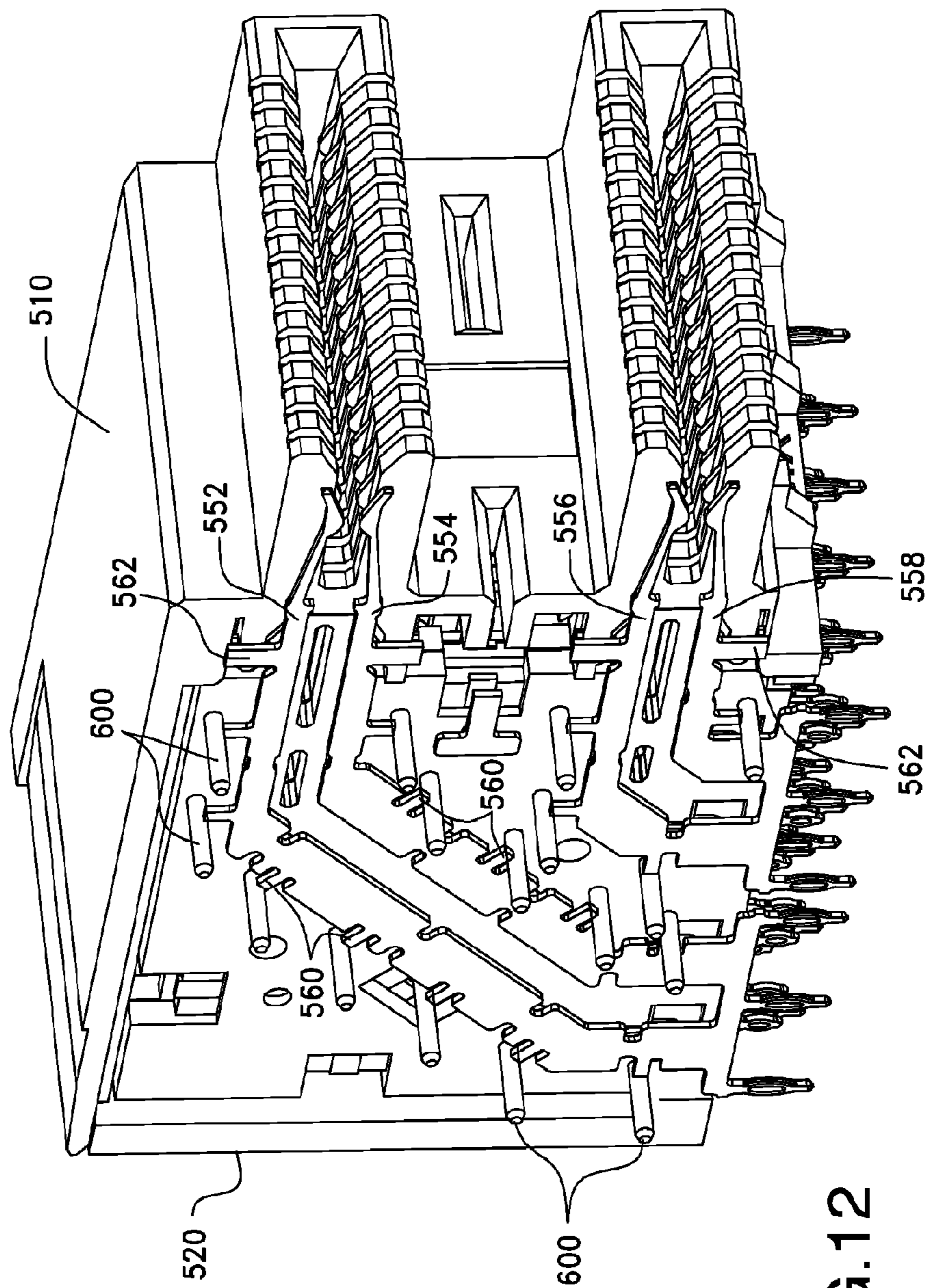

FIG.12

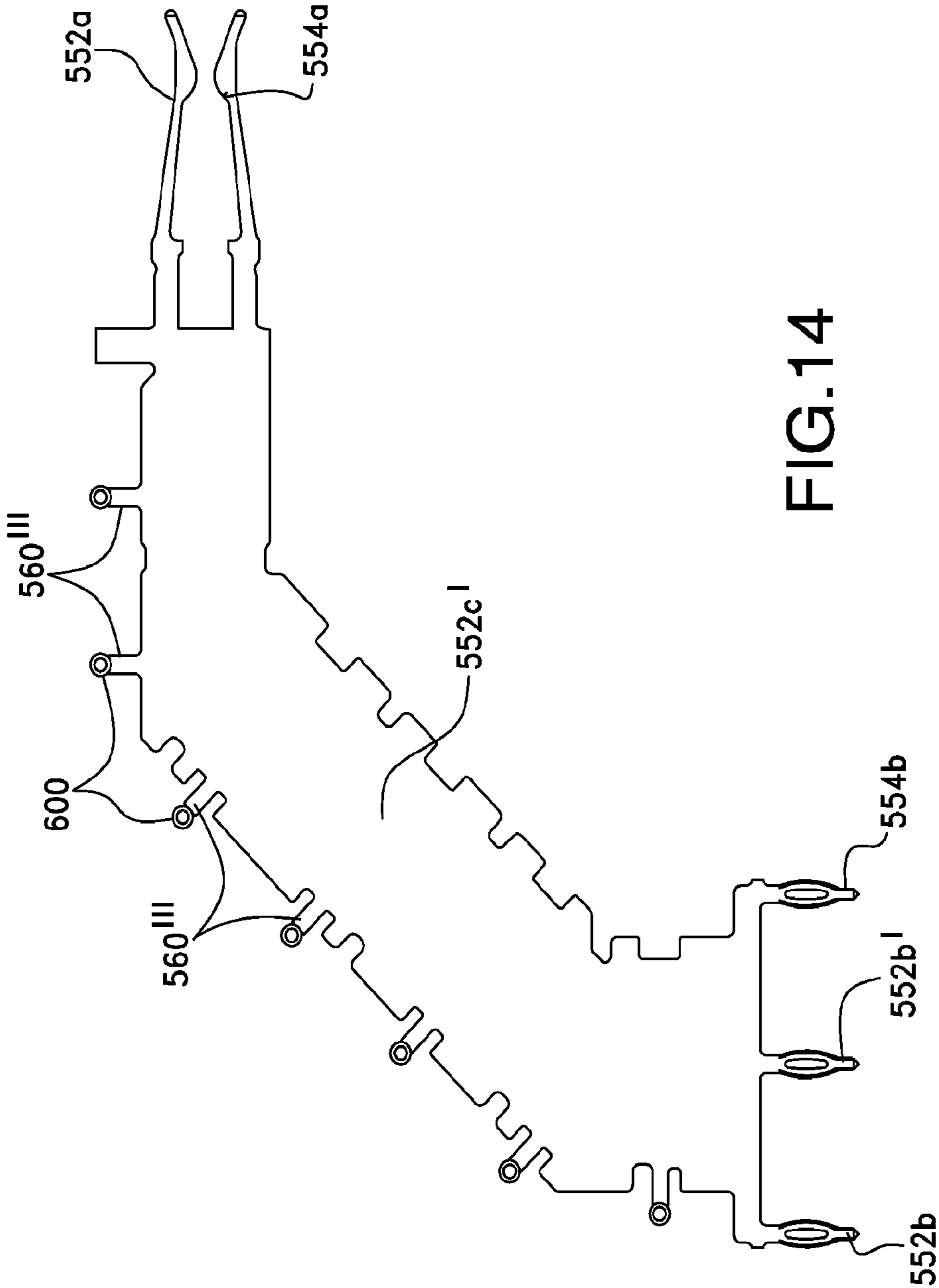

FIG.14

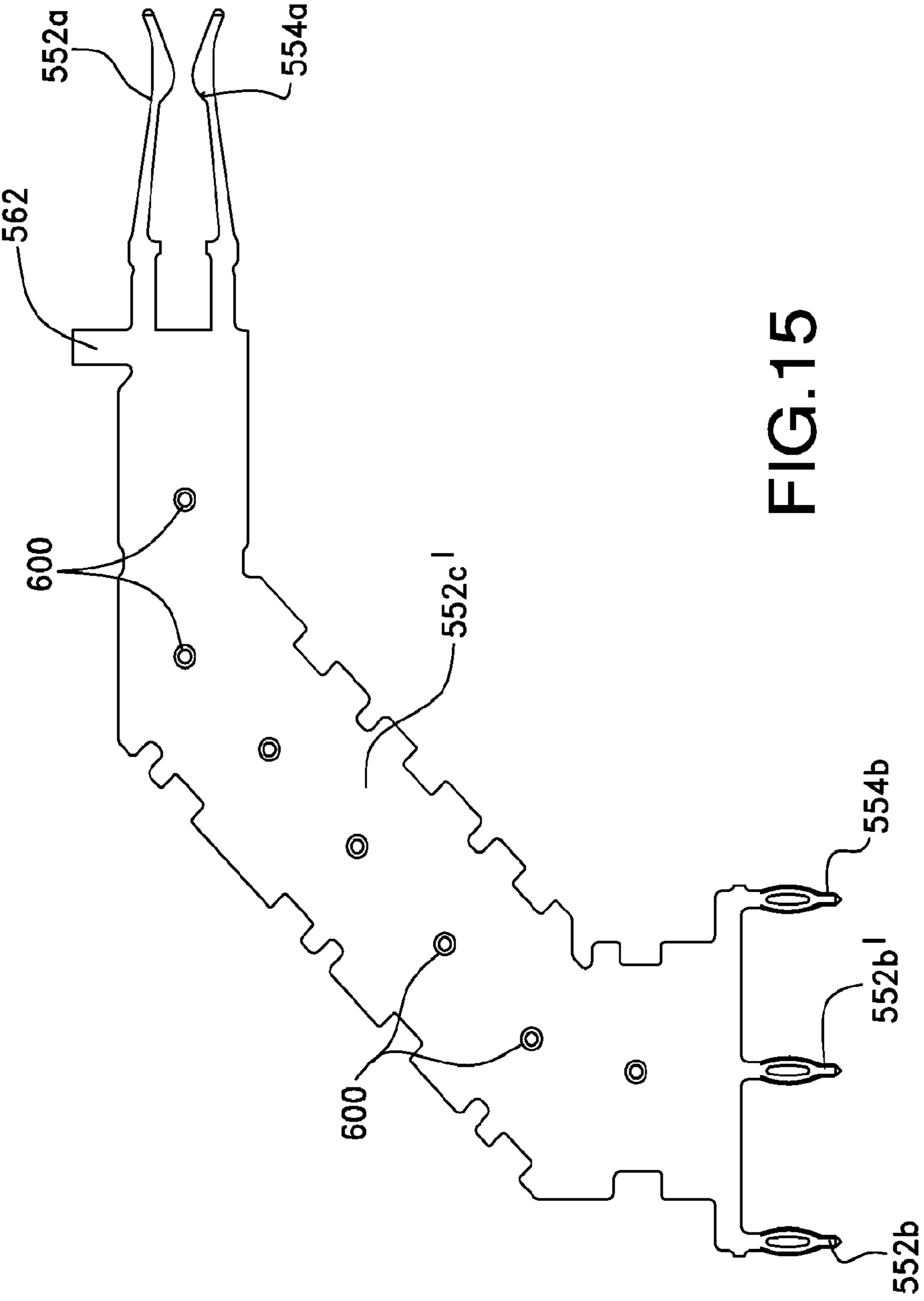

FIG.15

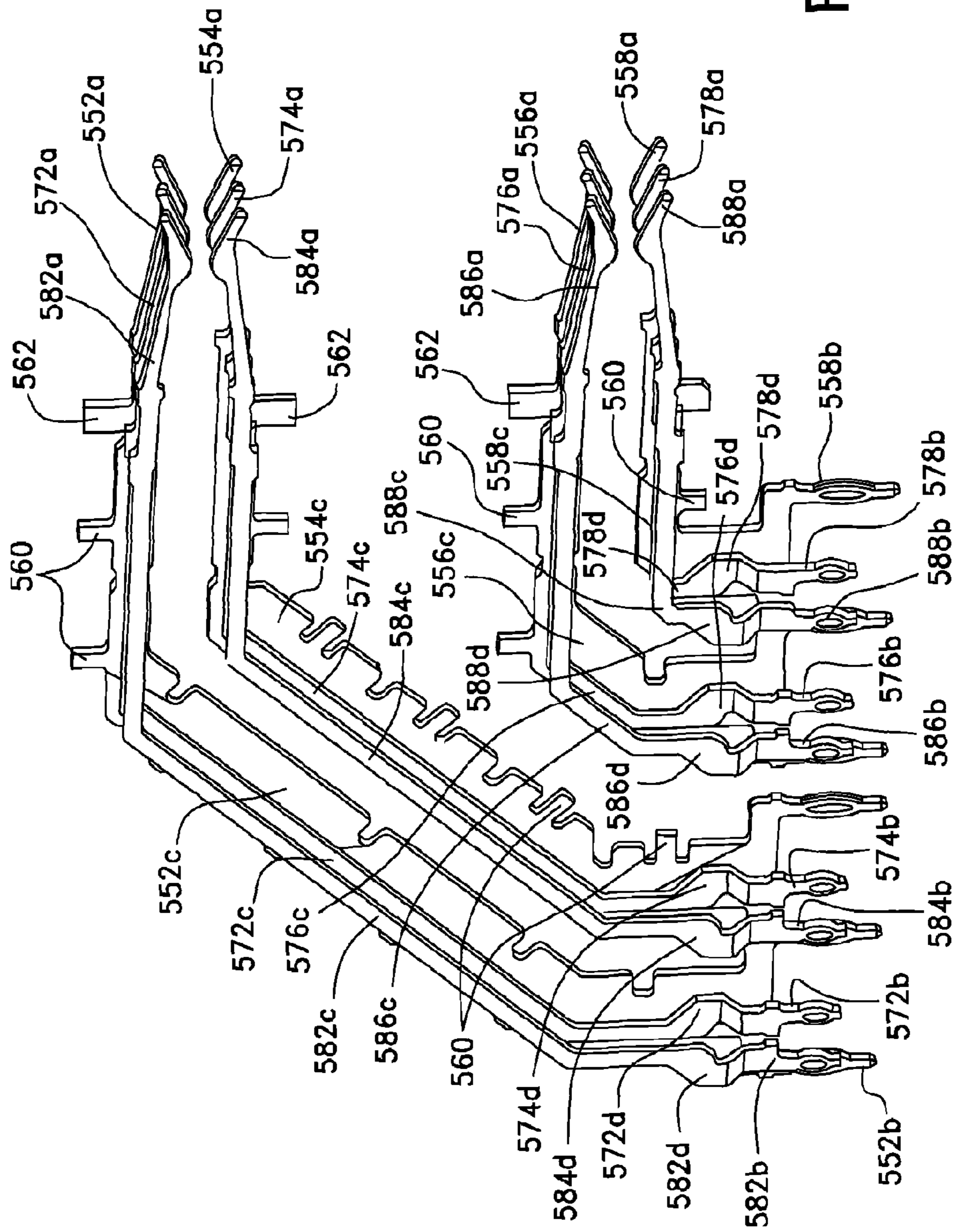

FIG.16

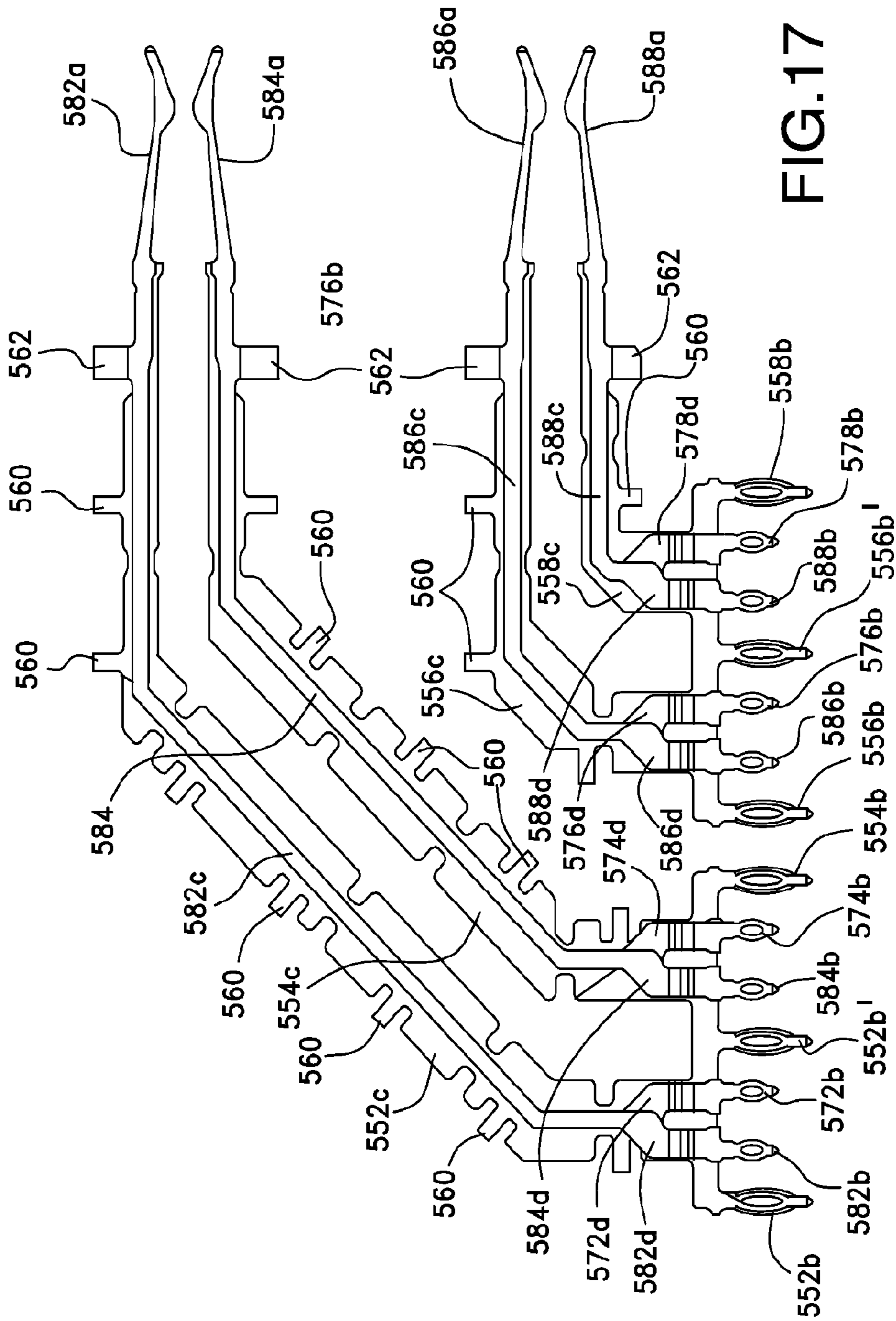

FIG.17

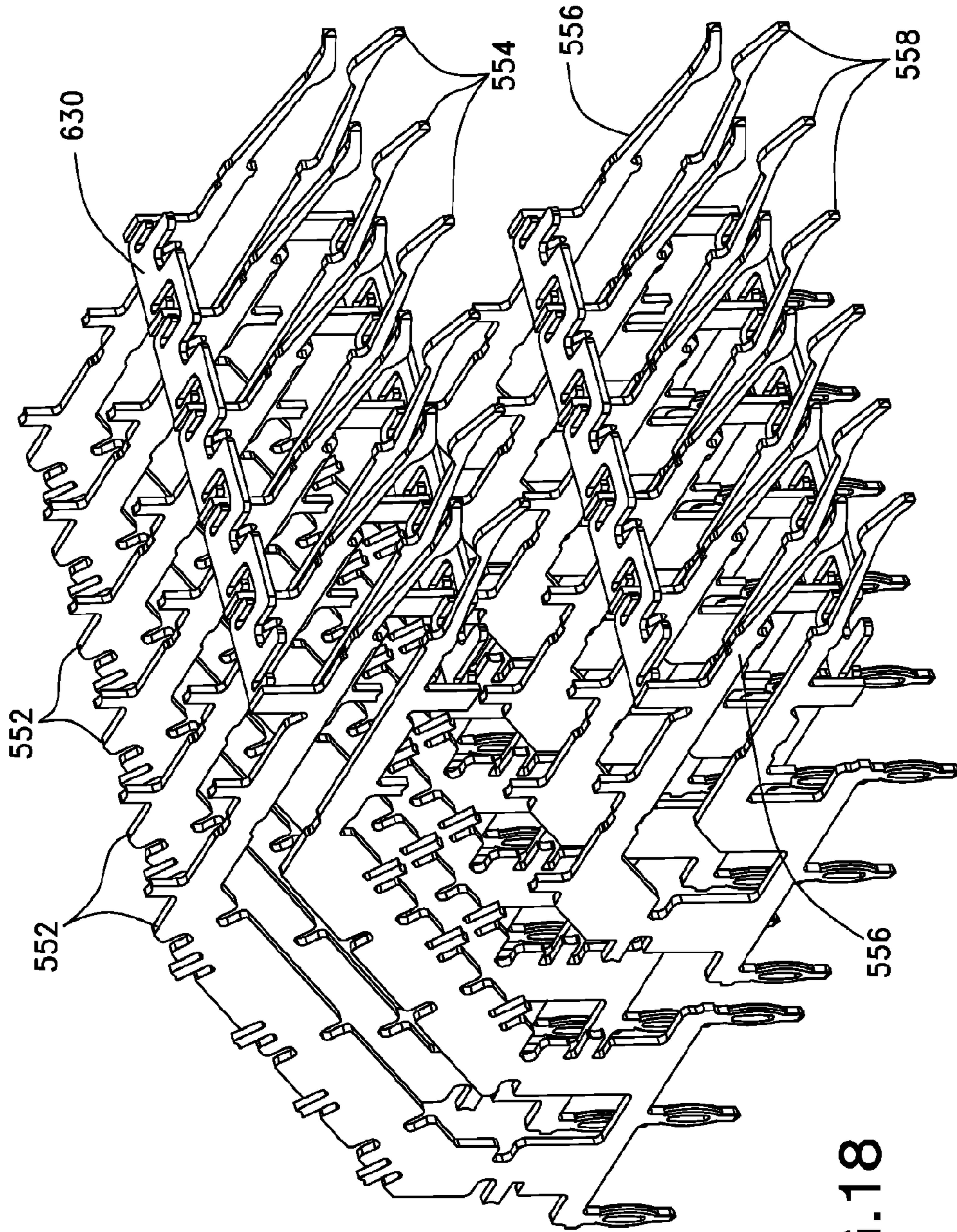

FIG.18

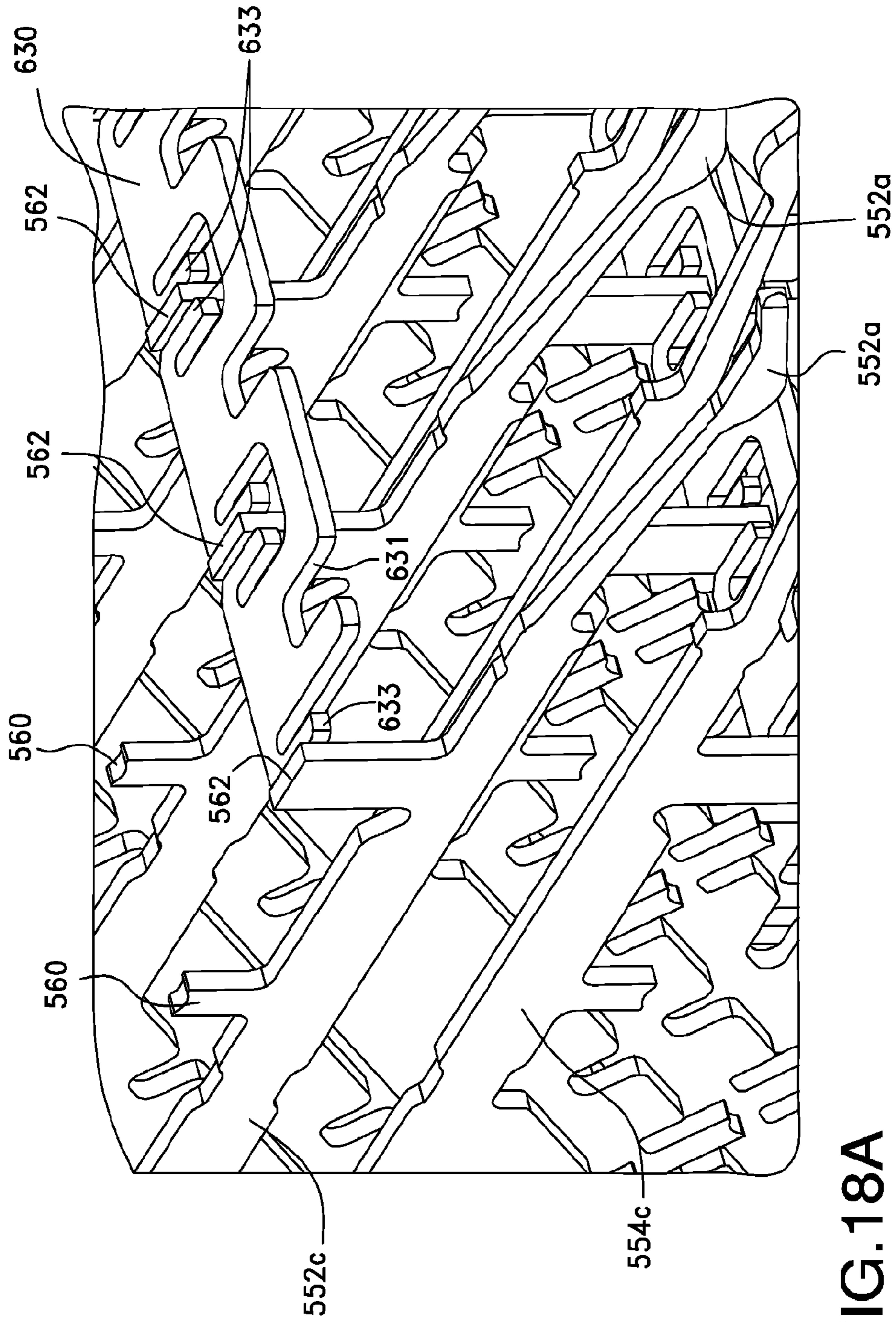

FIG. 18A

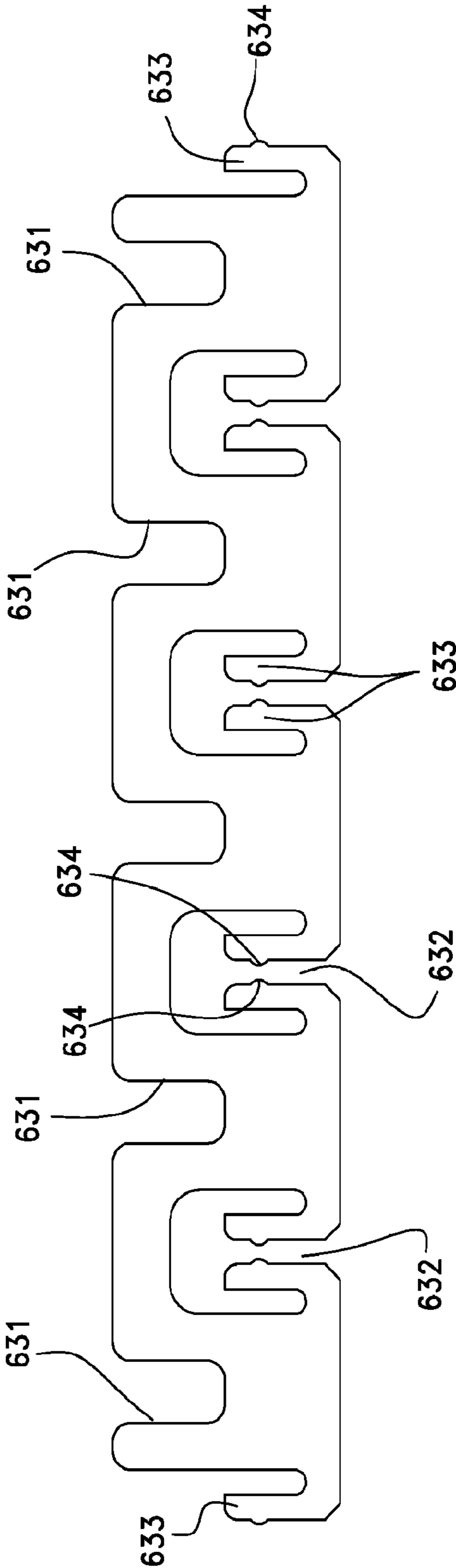

FIG.19

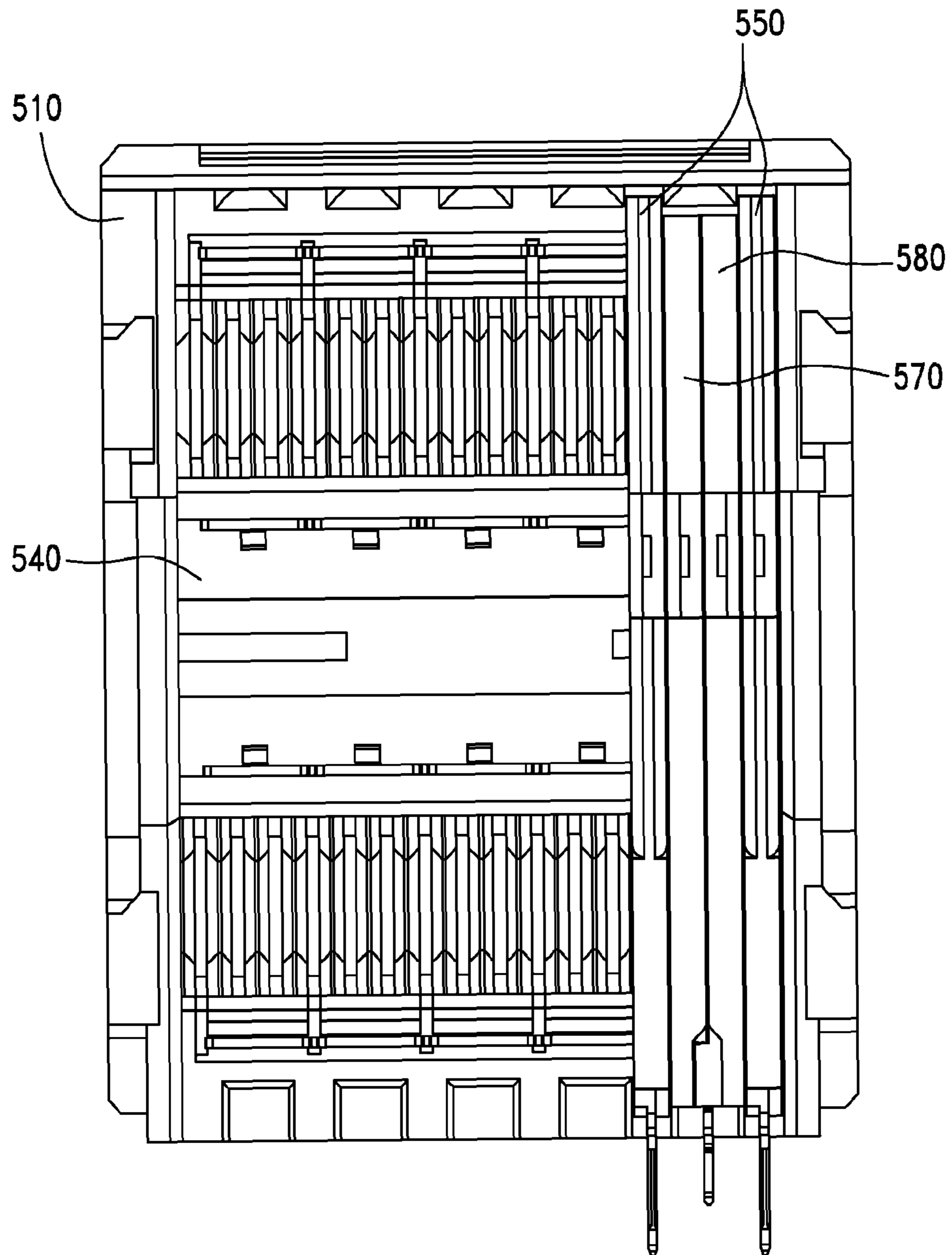

FIG.20

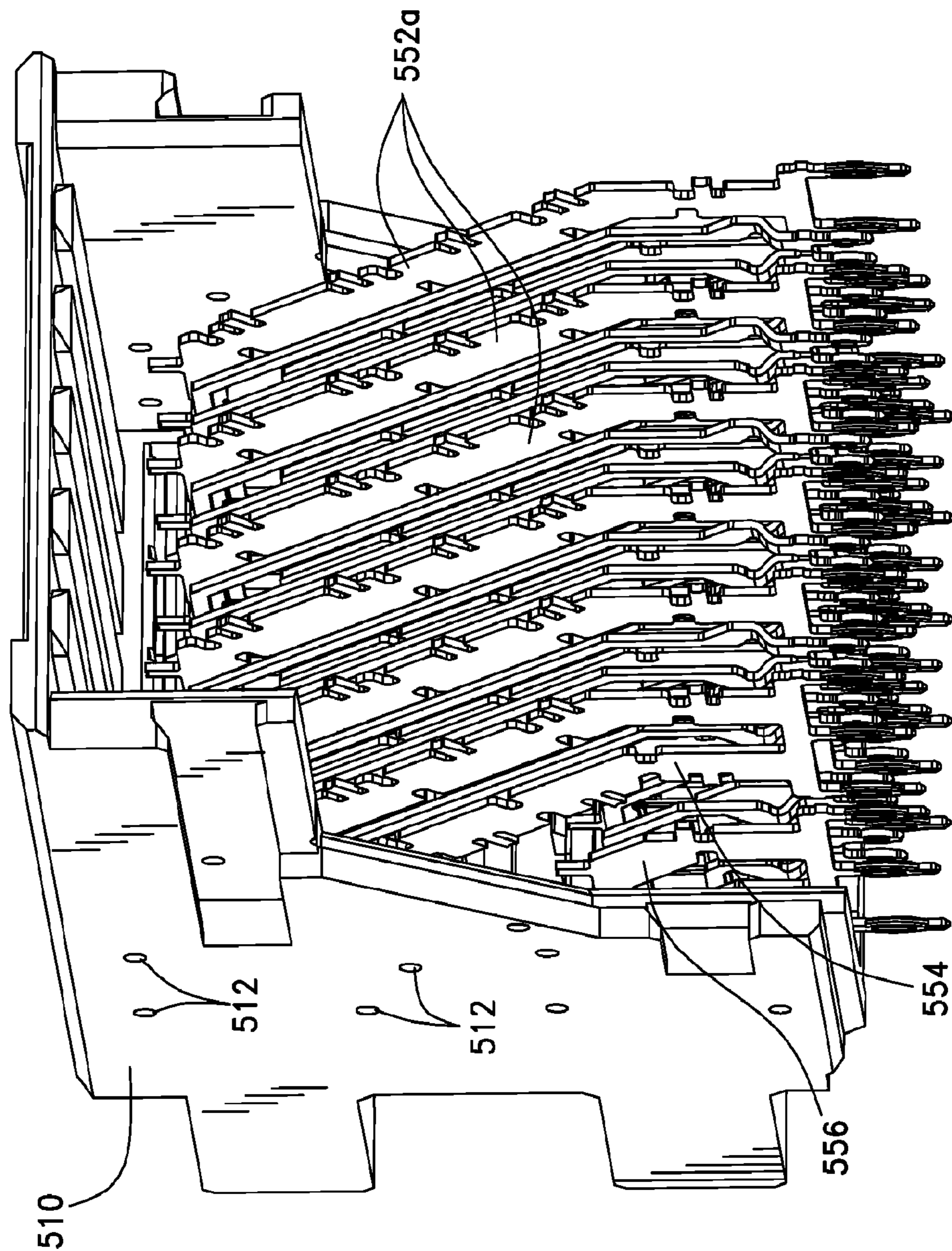

FIG.21

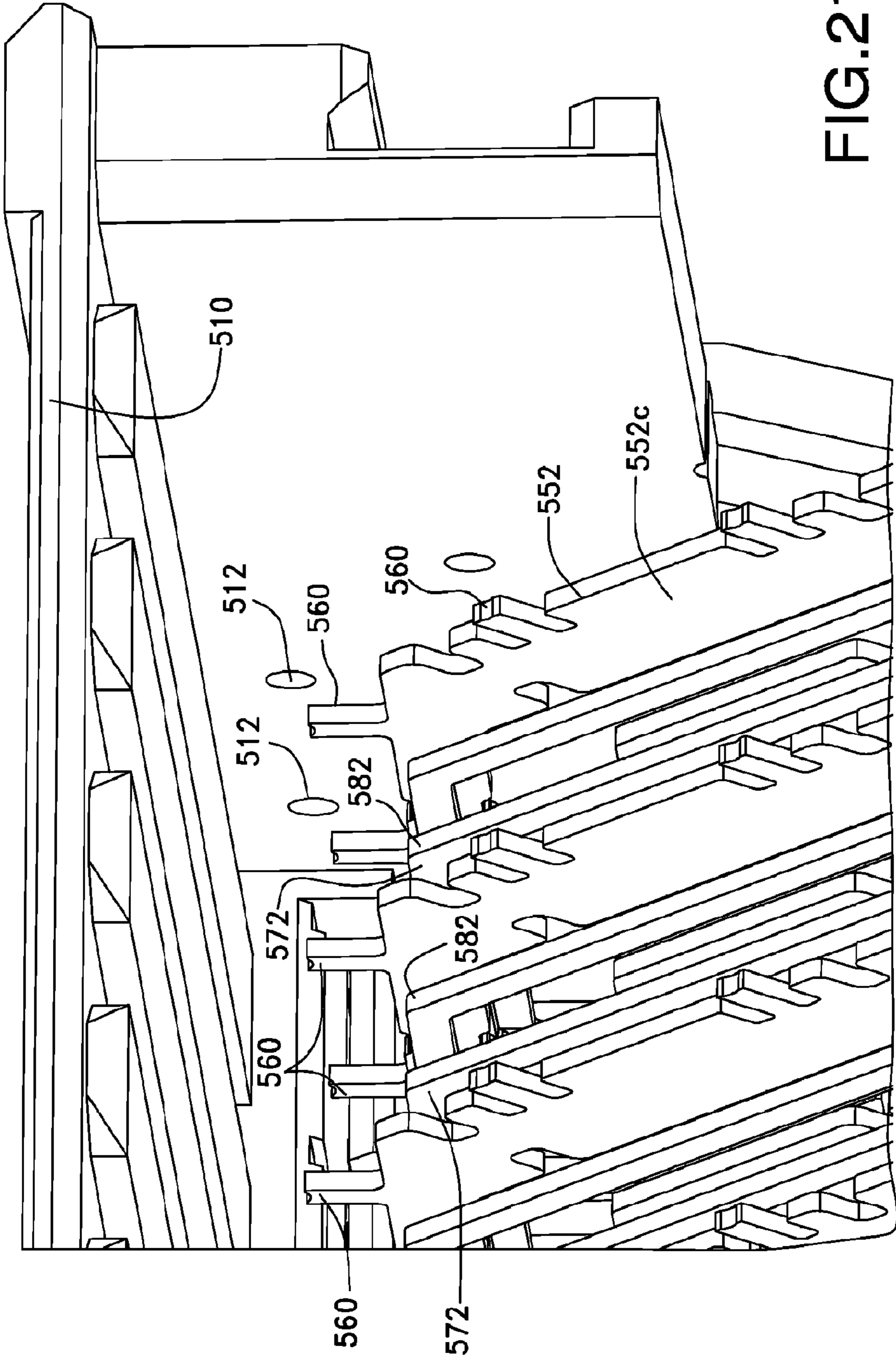

FIG.21A

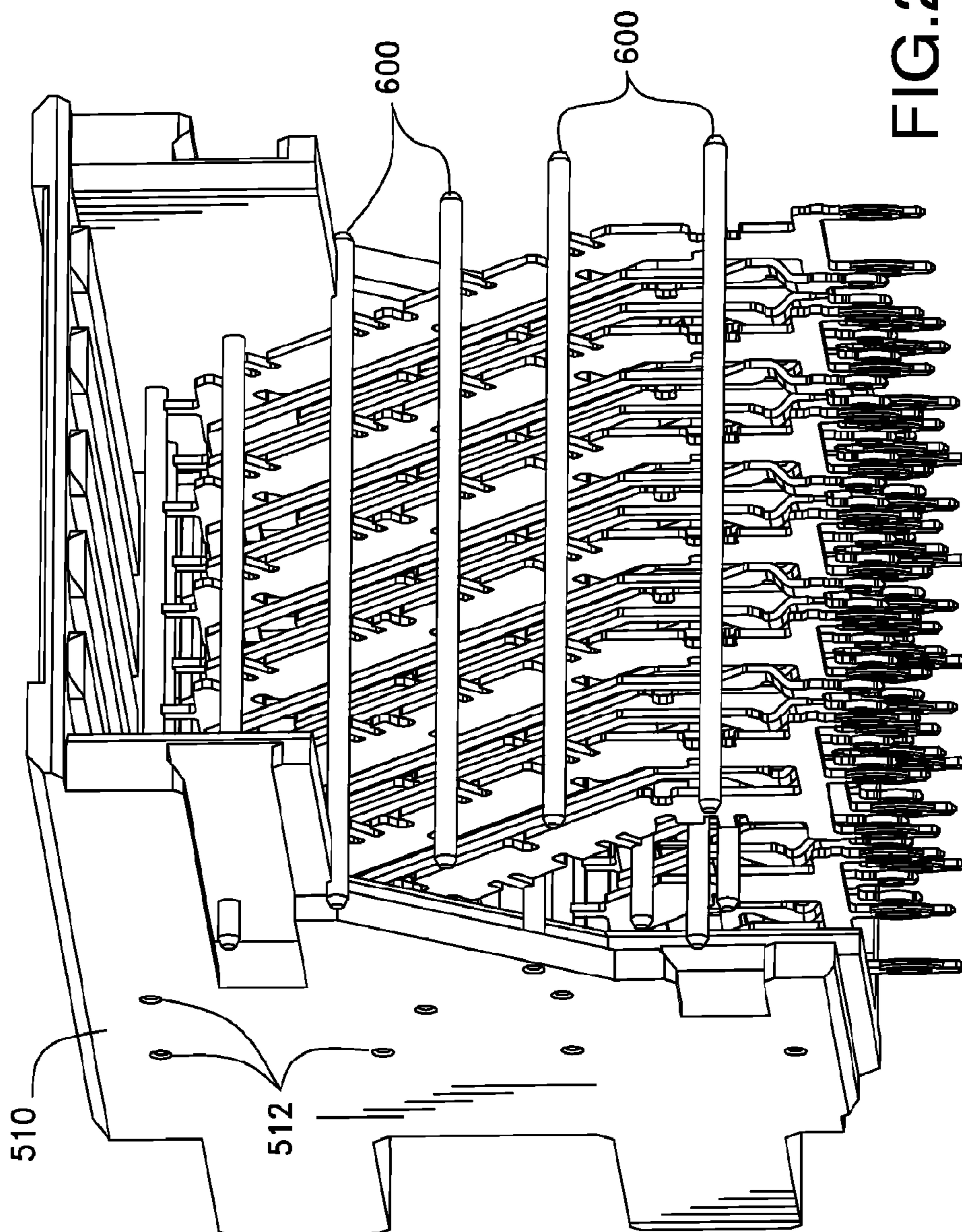
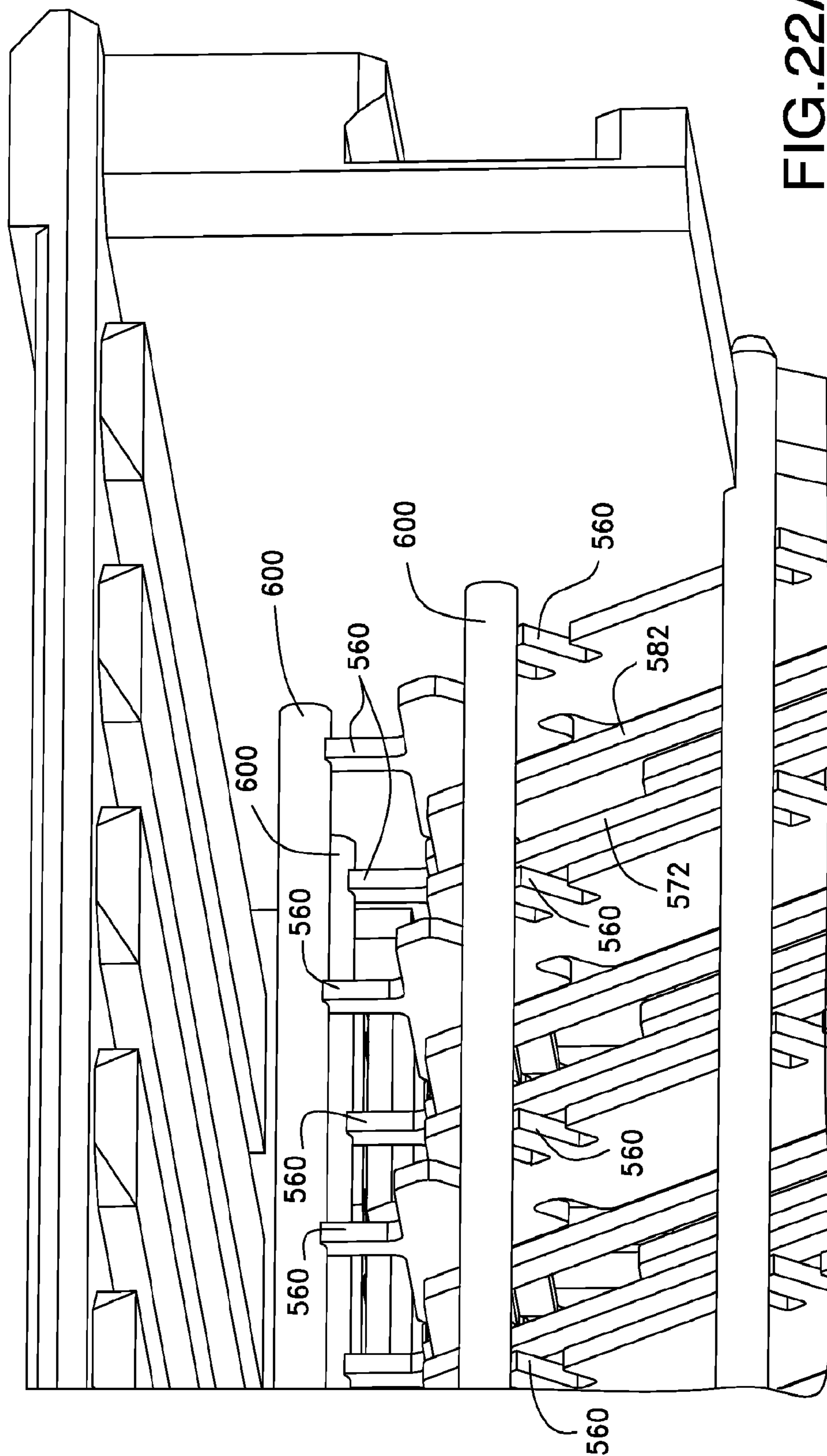

FIG.22



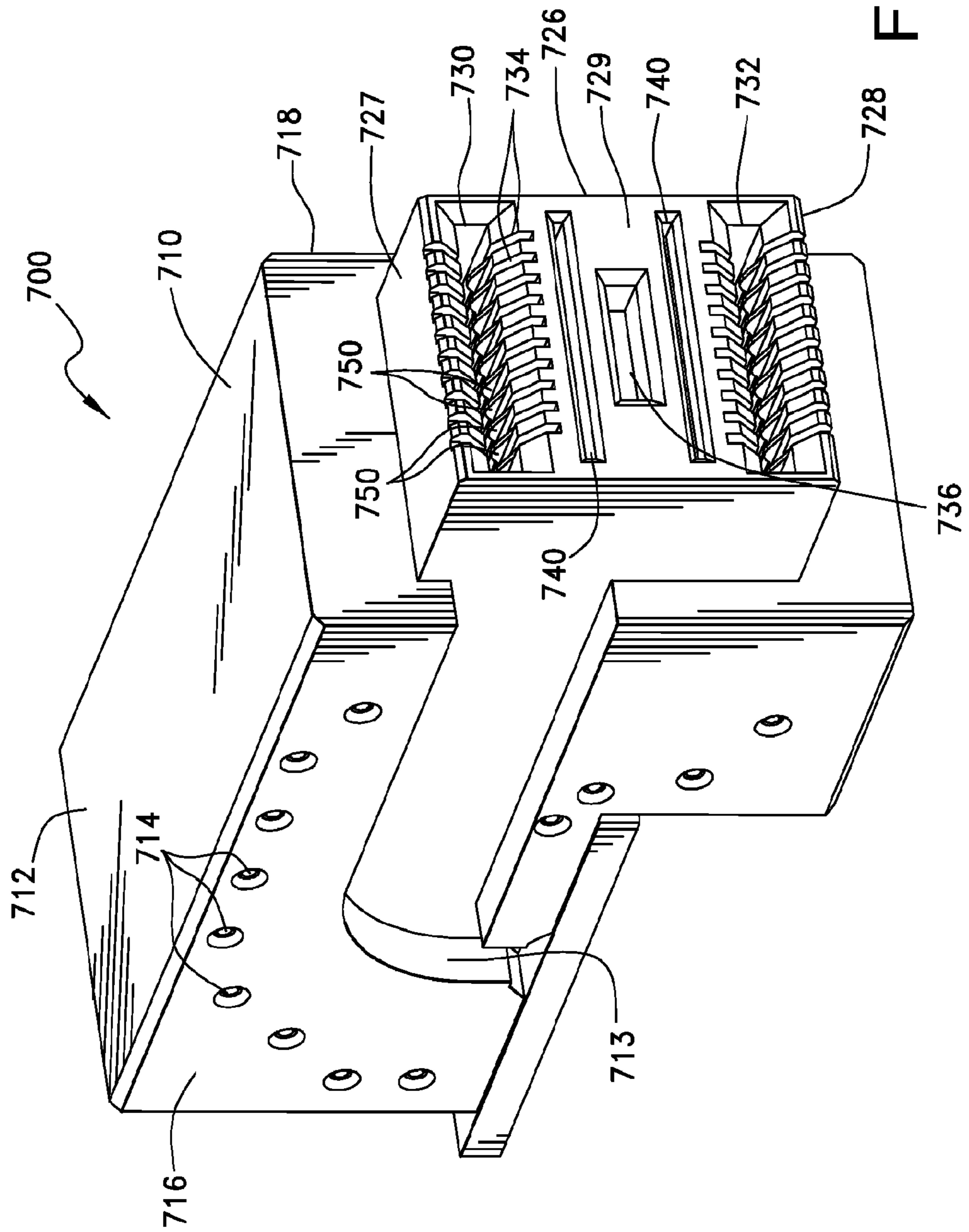

FIG. 23

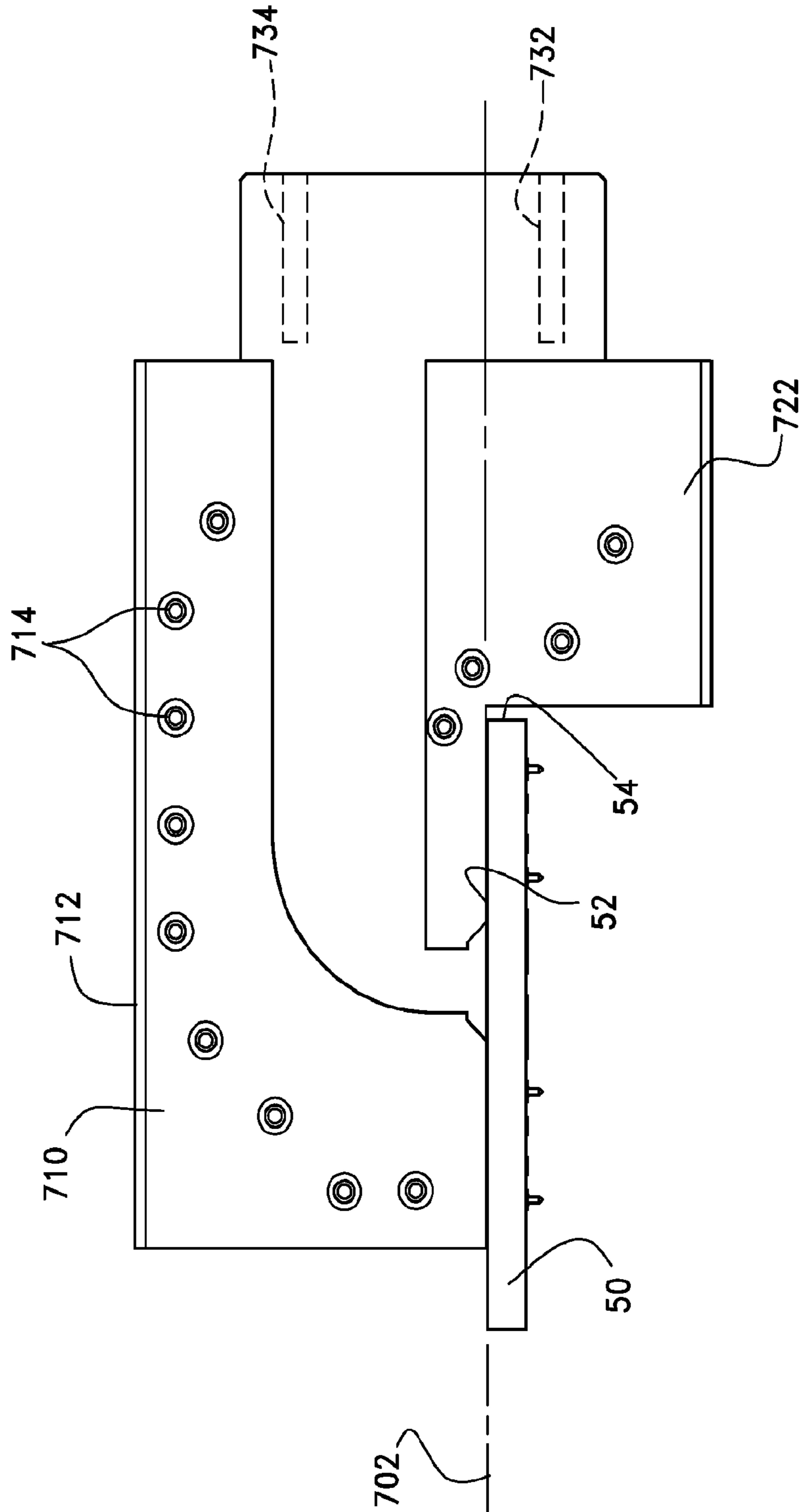

FIG.24

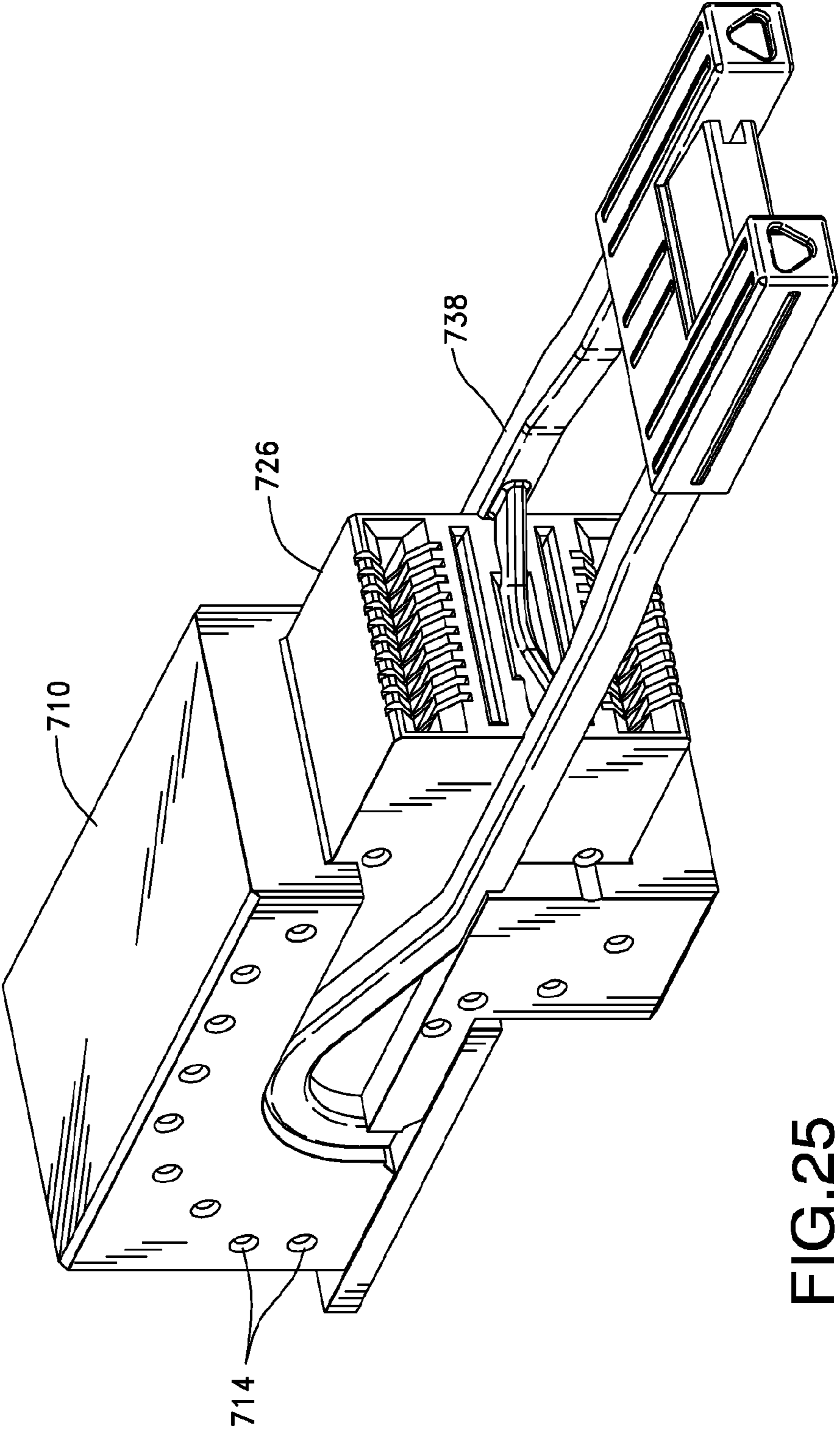

FIG.25

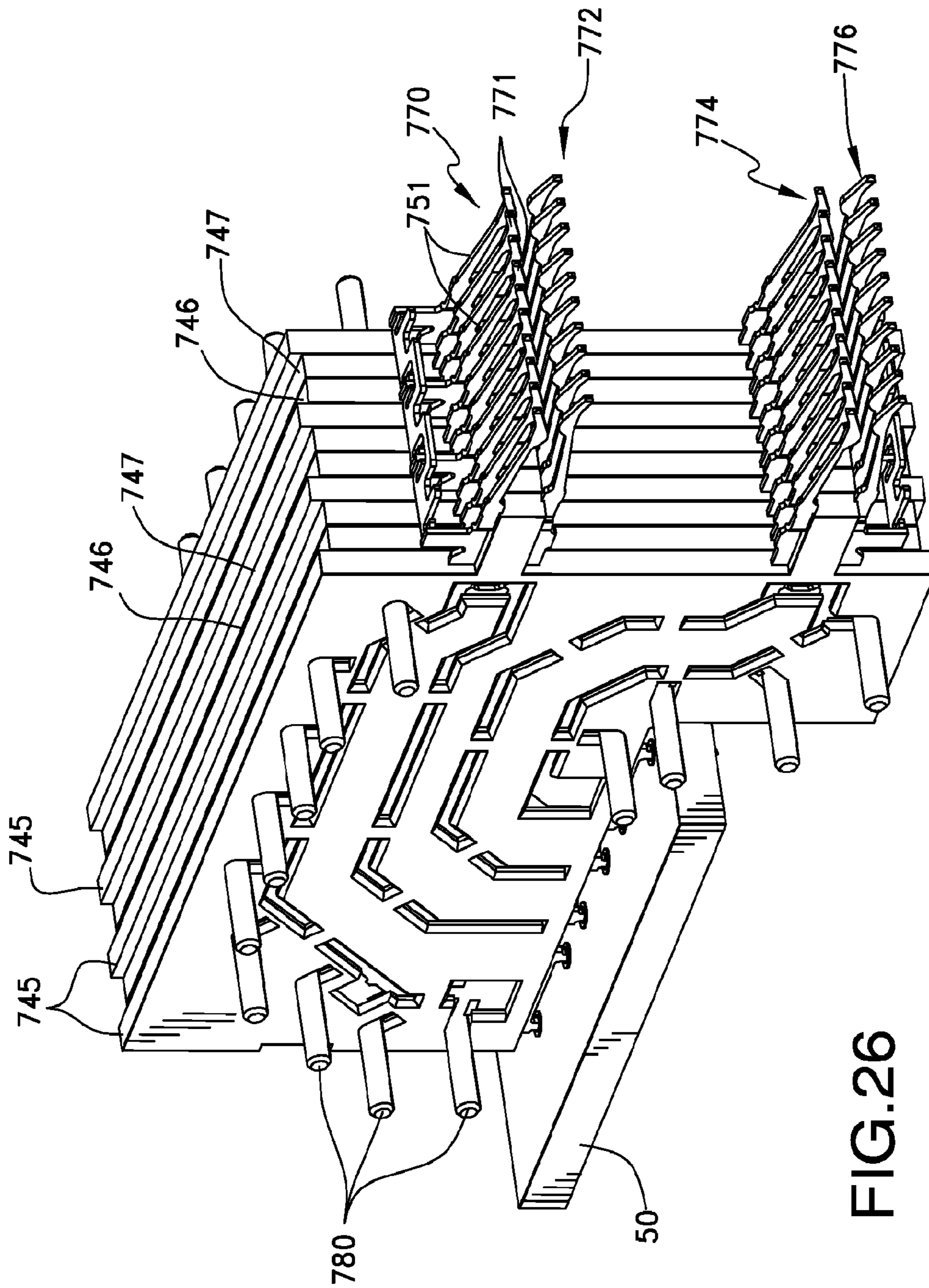

FIG. 26

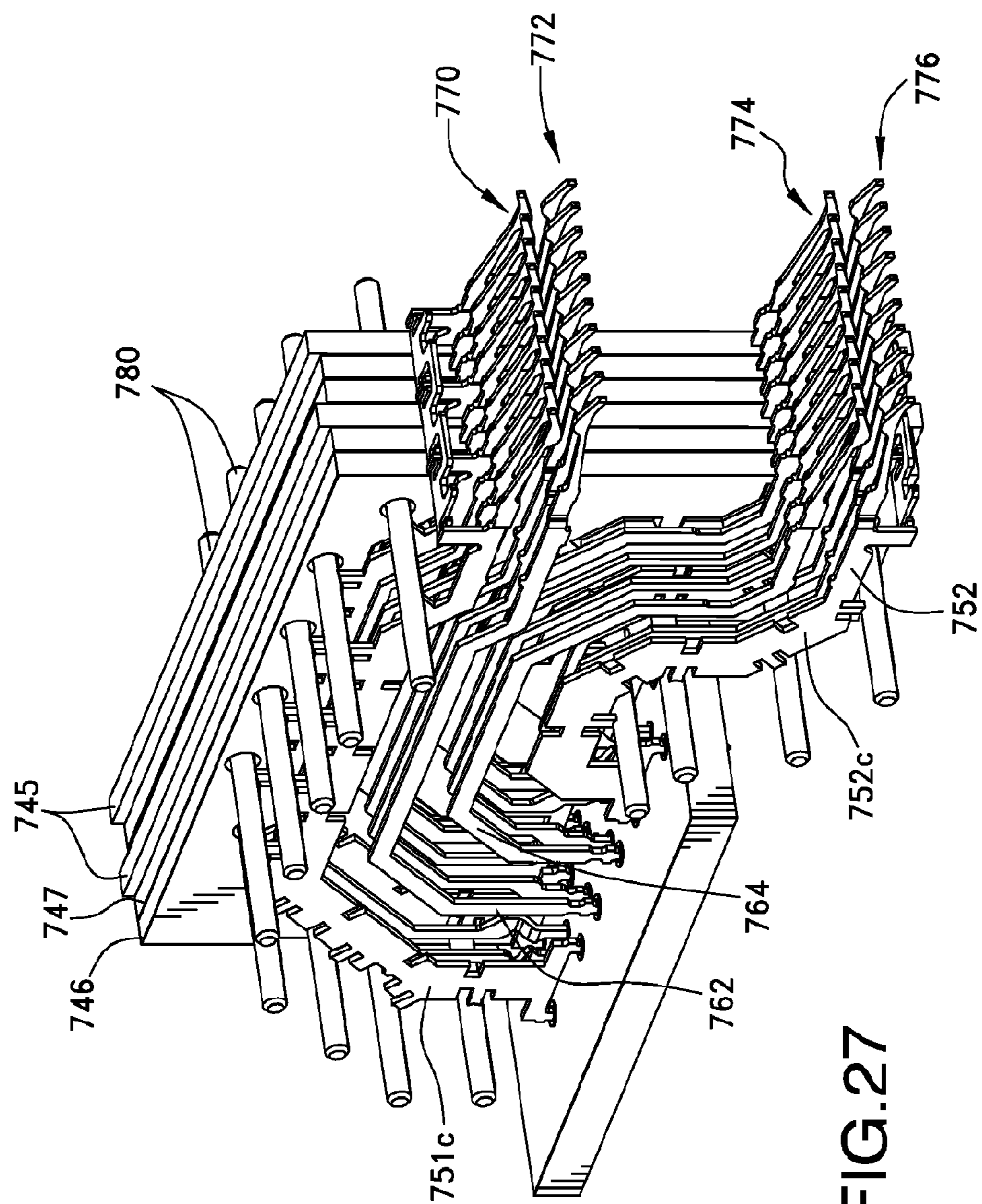

FIG. 27

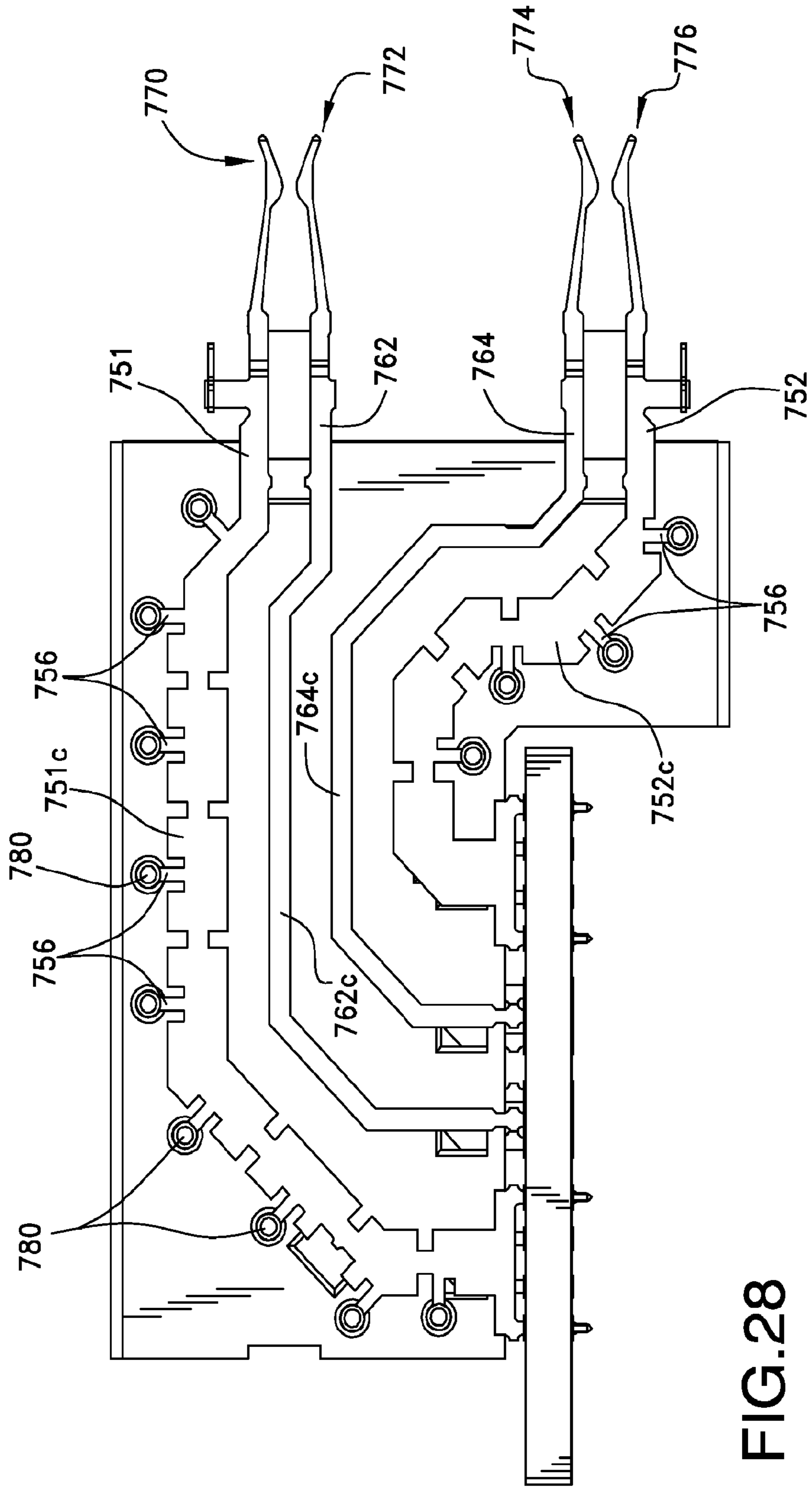

FIG.28

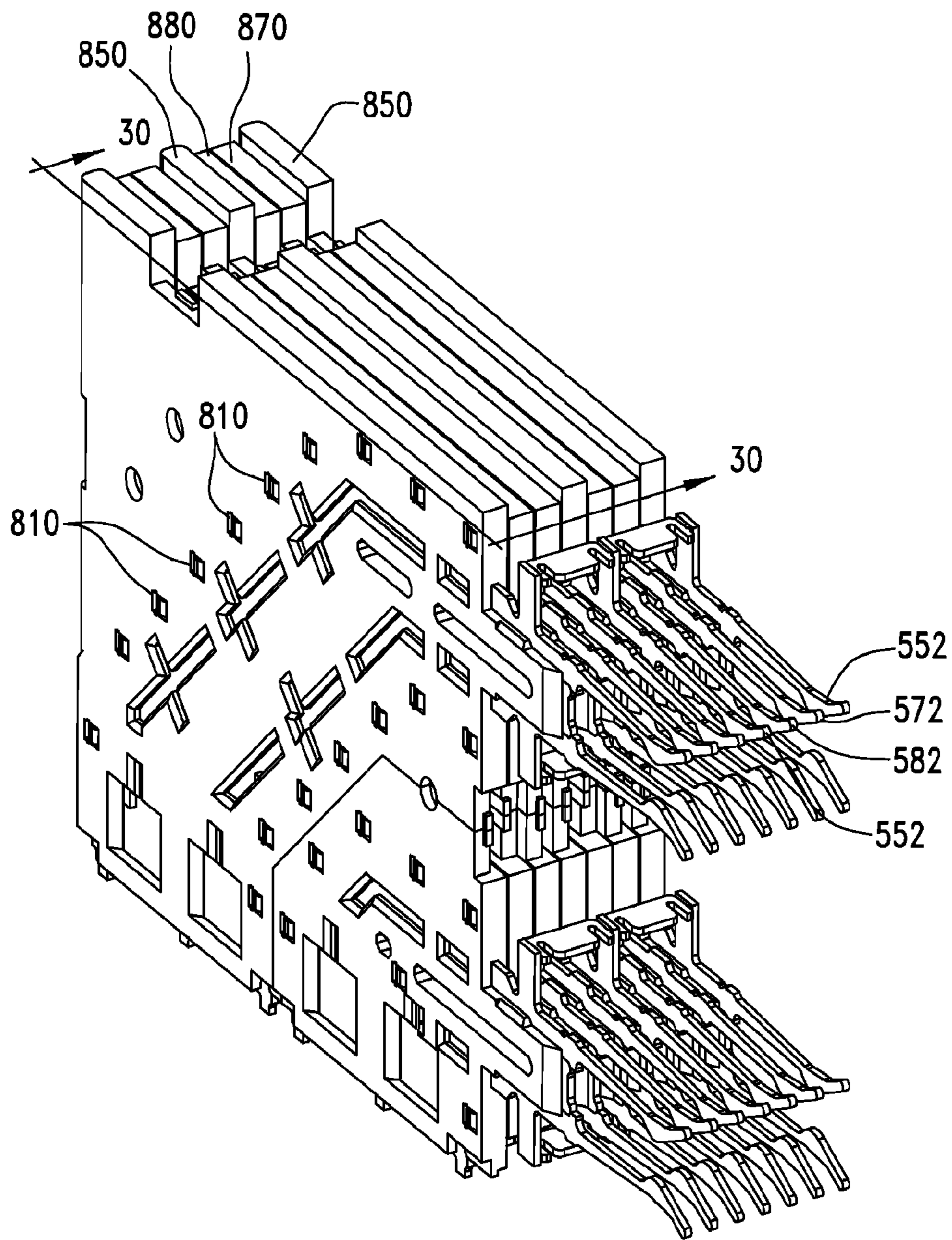

FIG.29

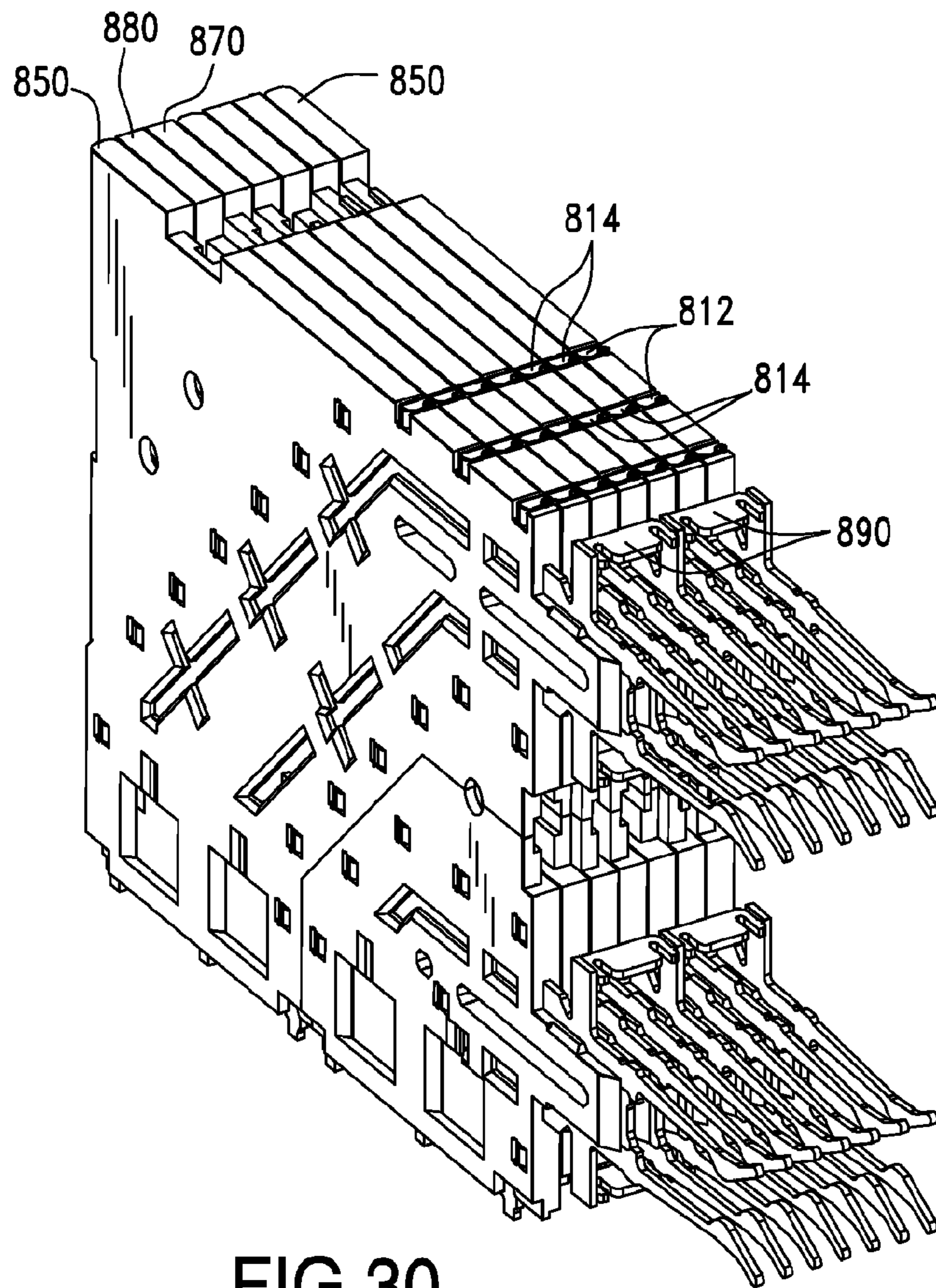

FIG.30

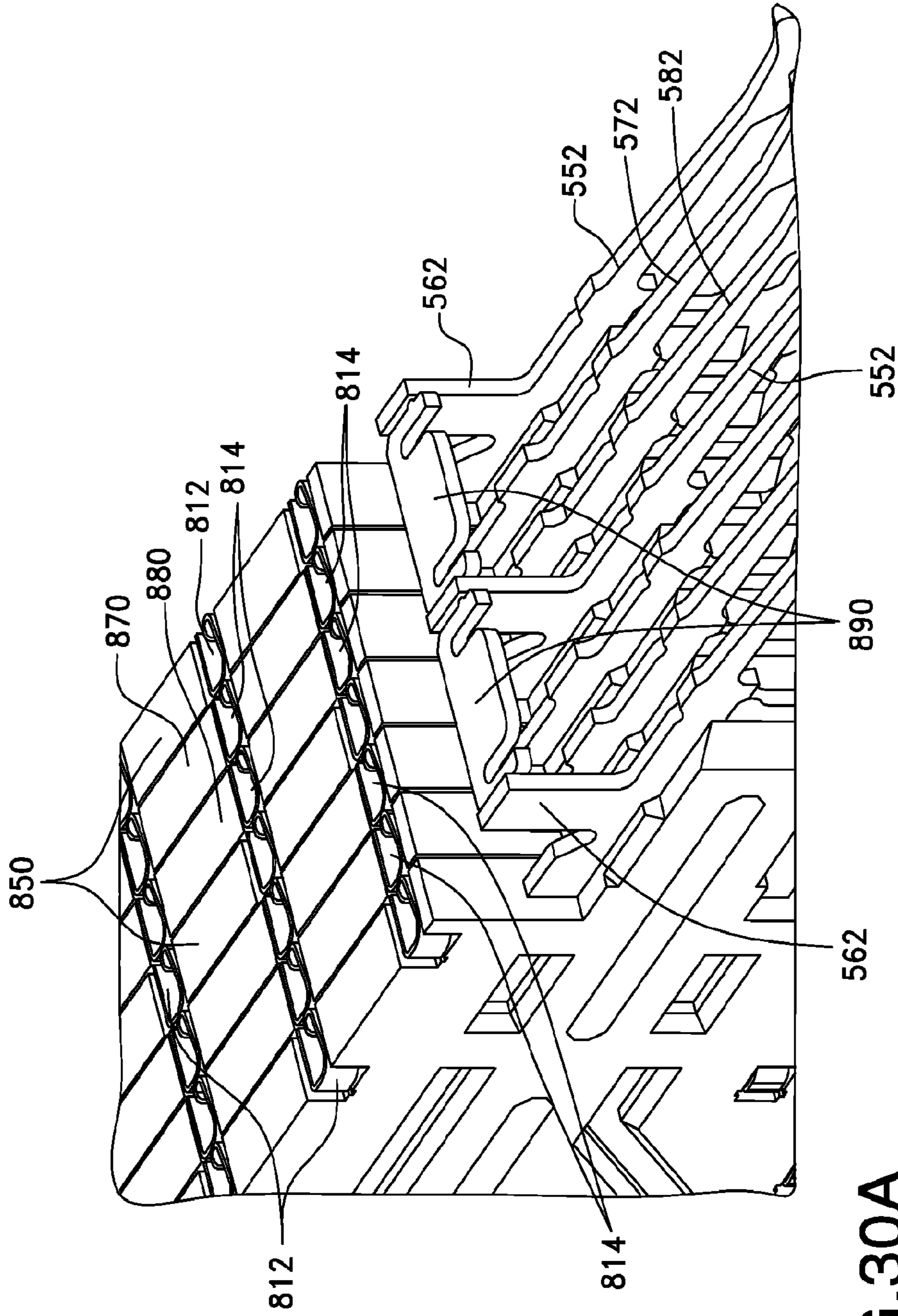

FIG.30A

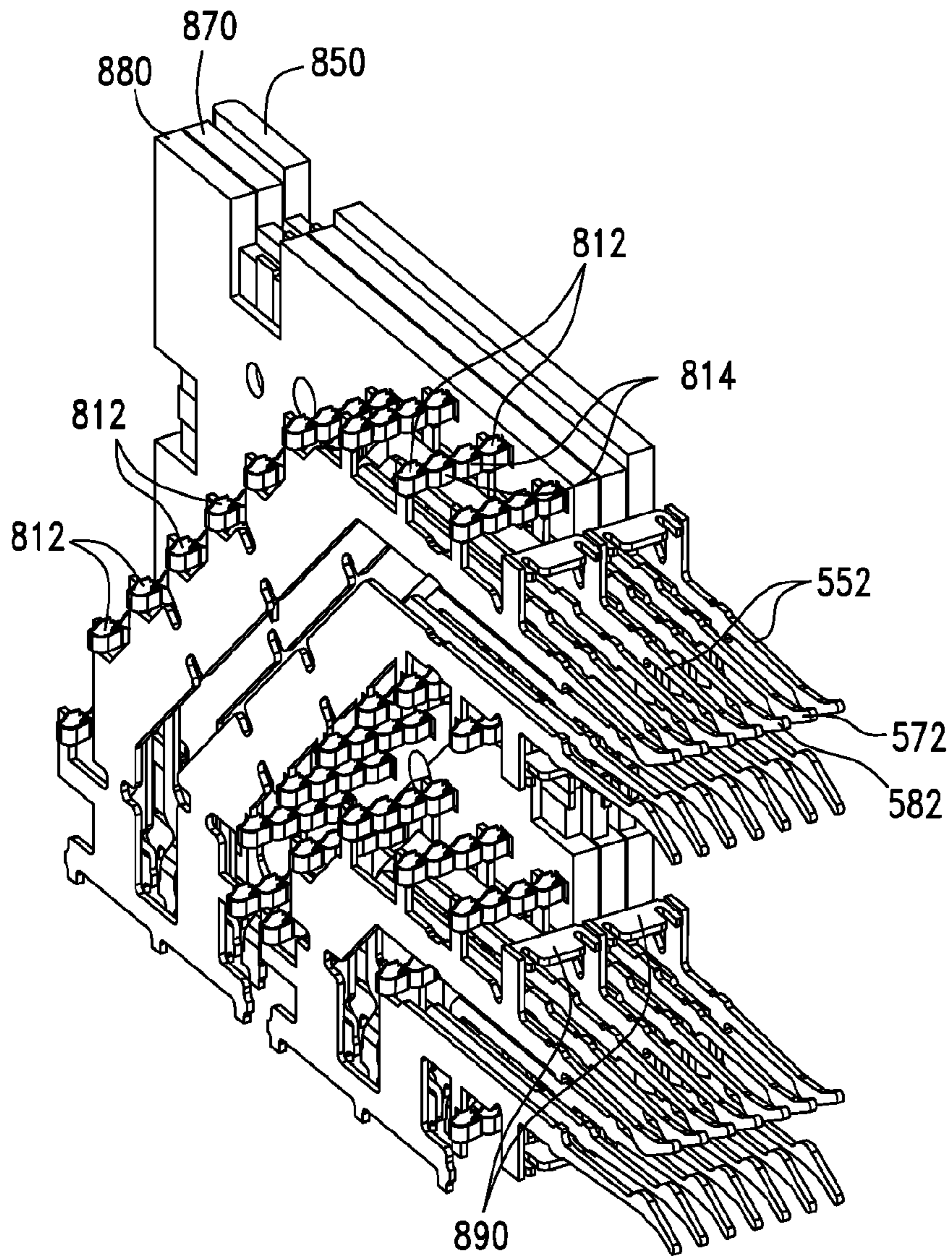
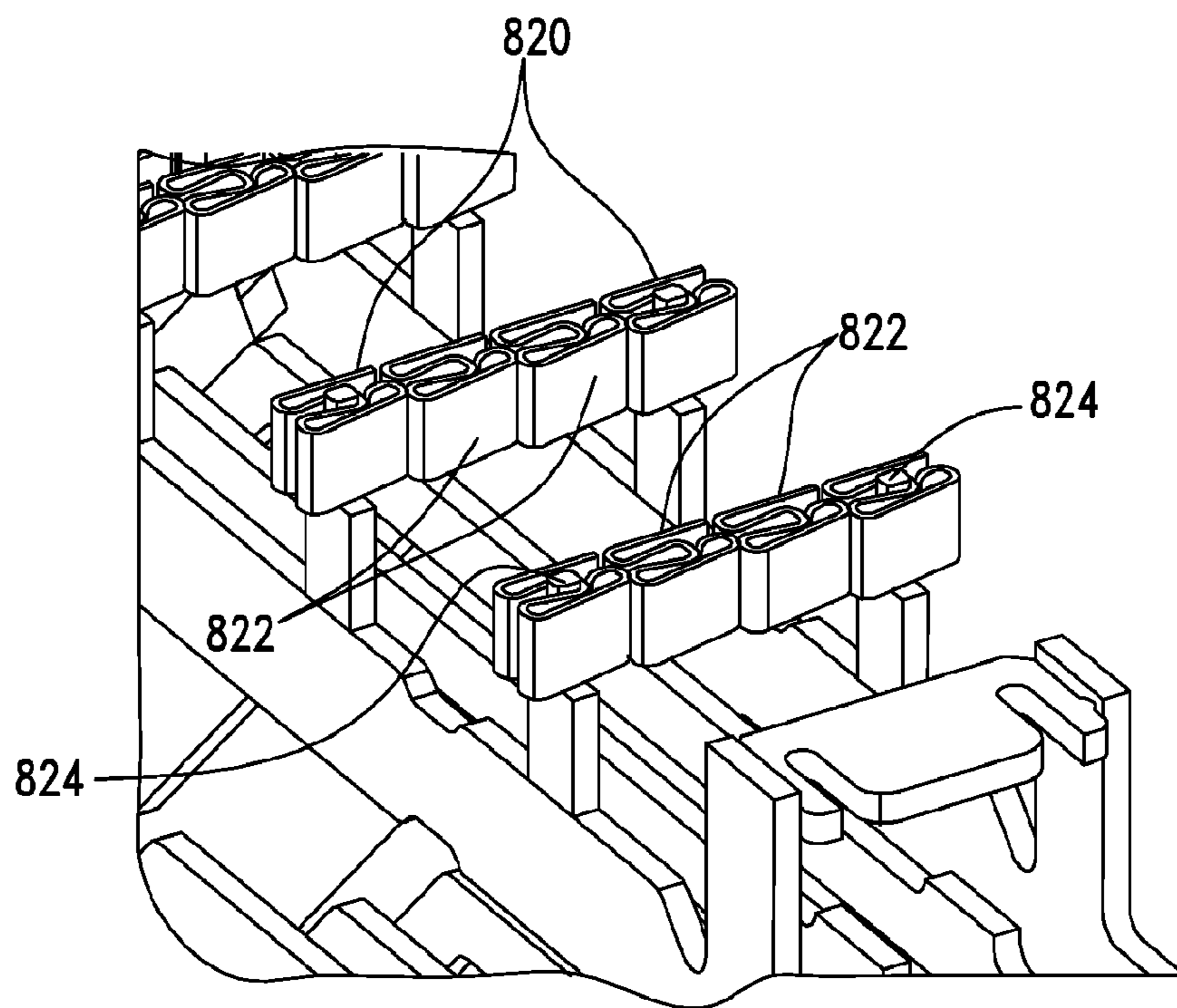
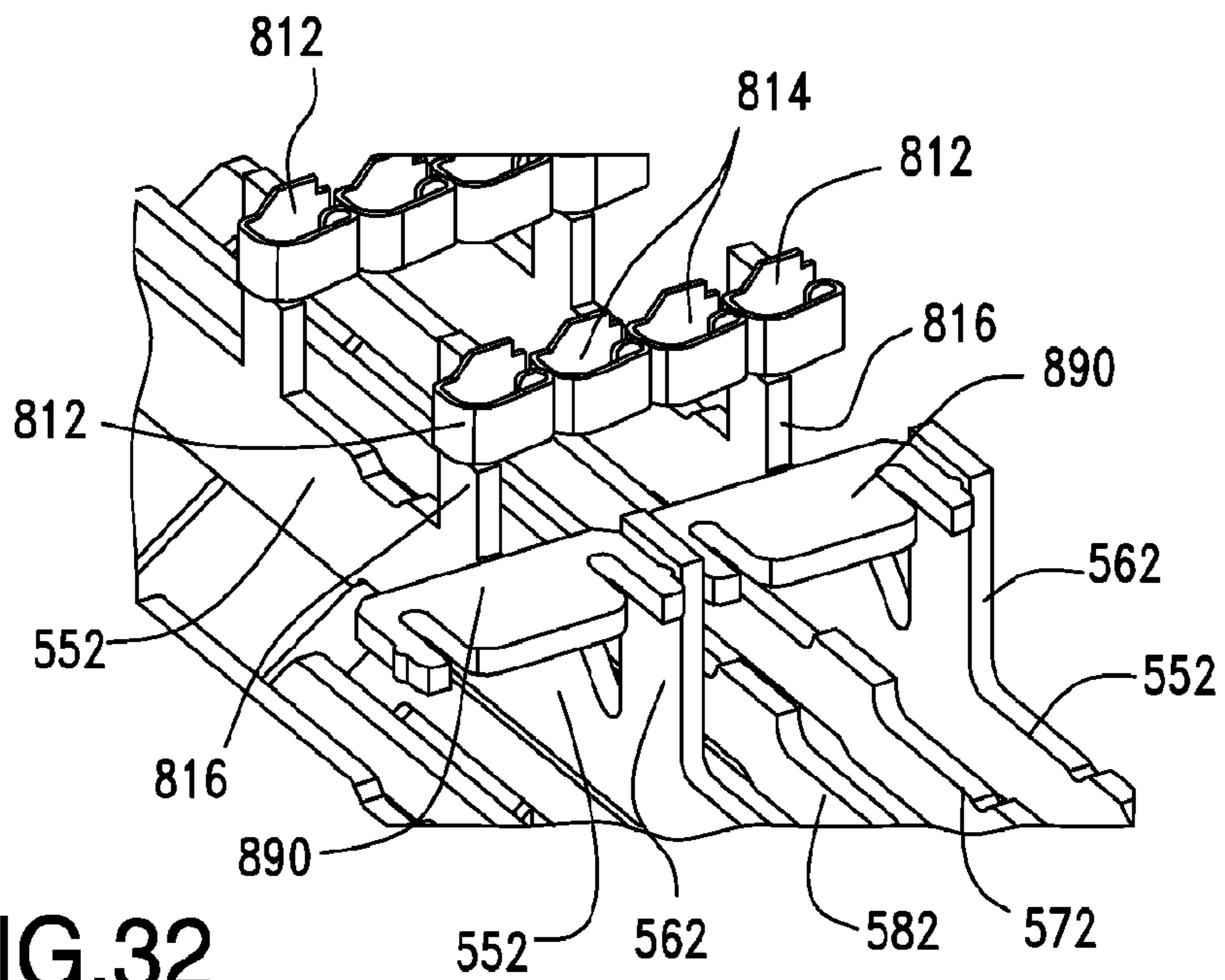

FIG.31



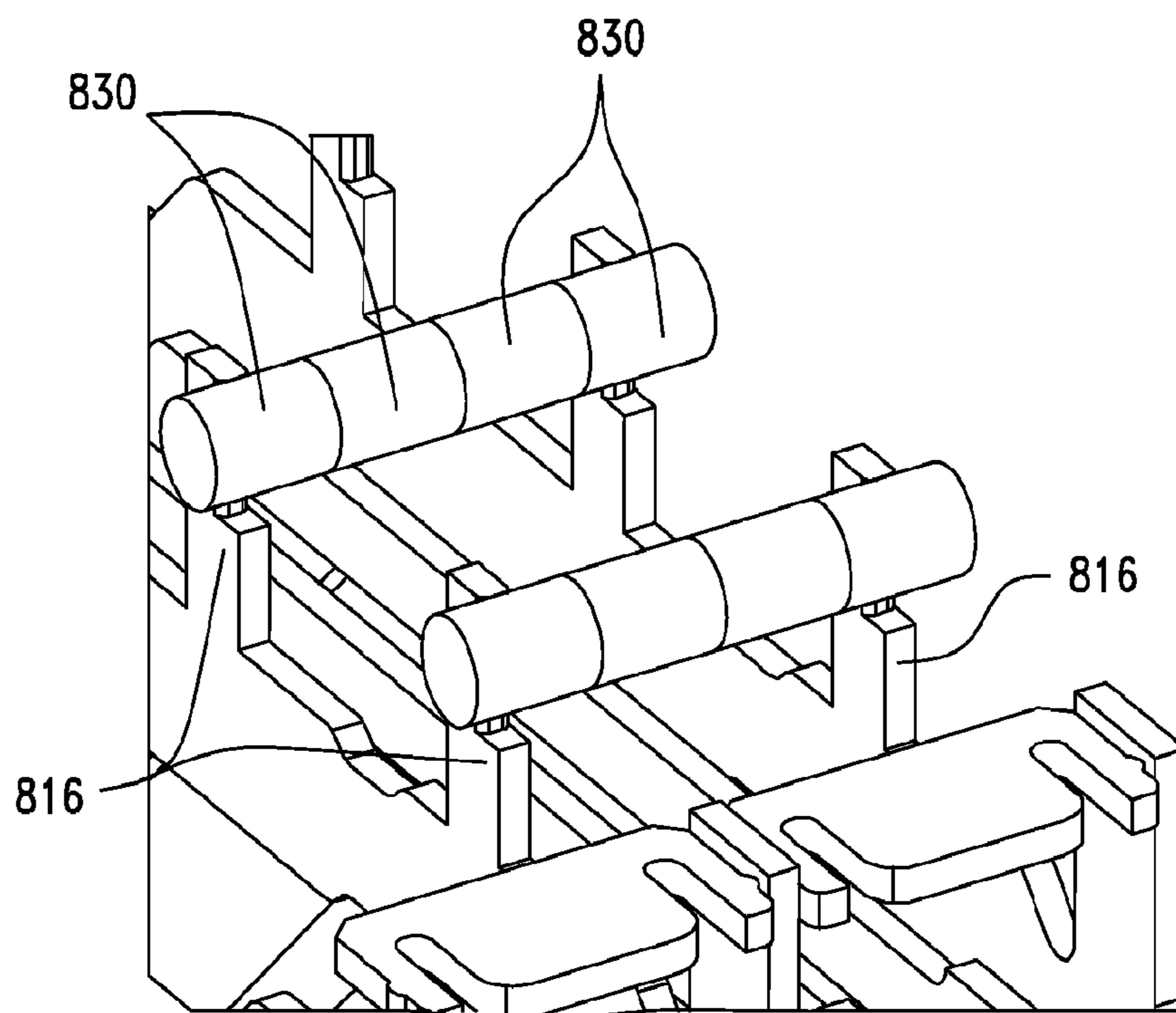

FIG.34

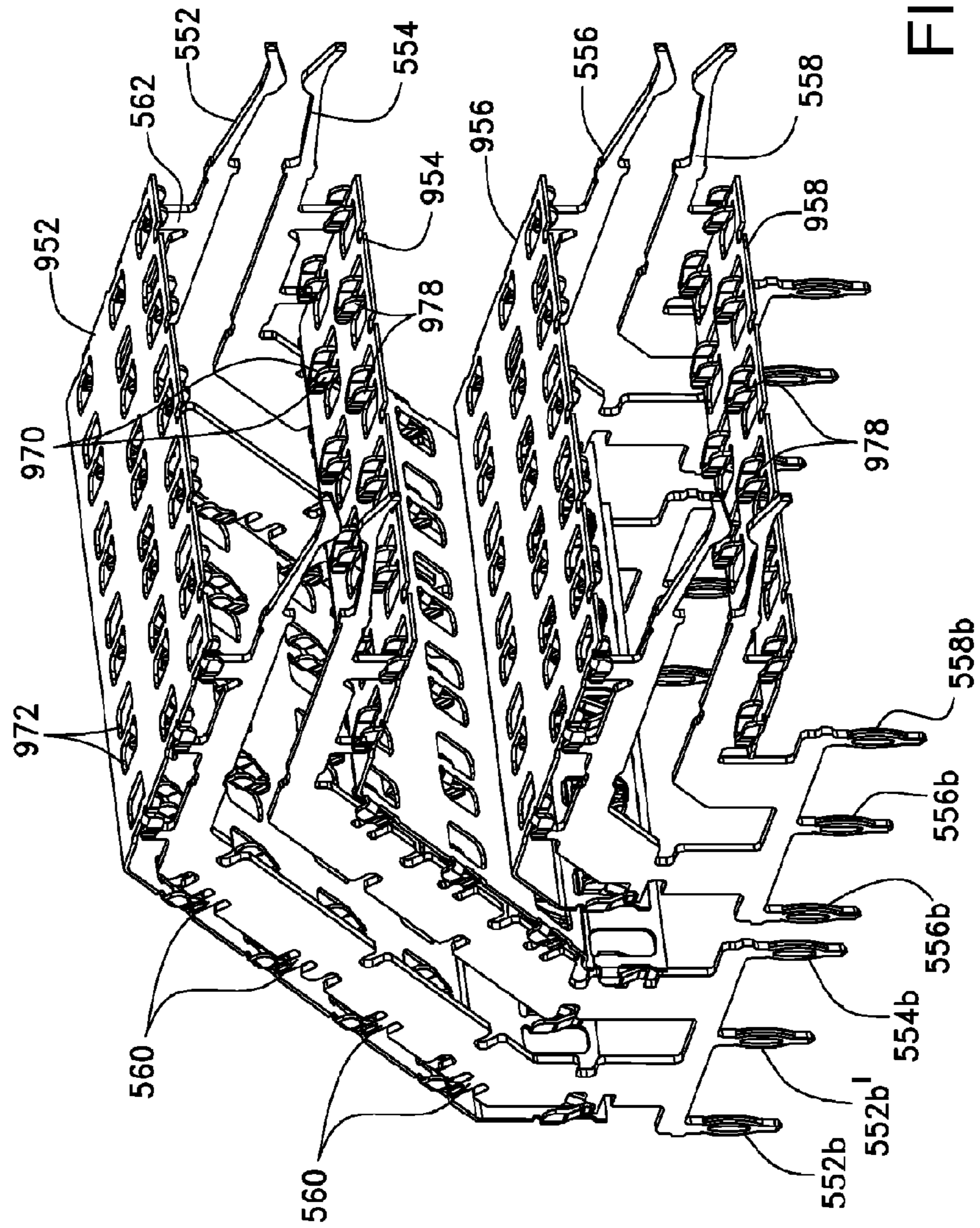

FIG.35

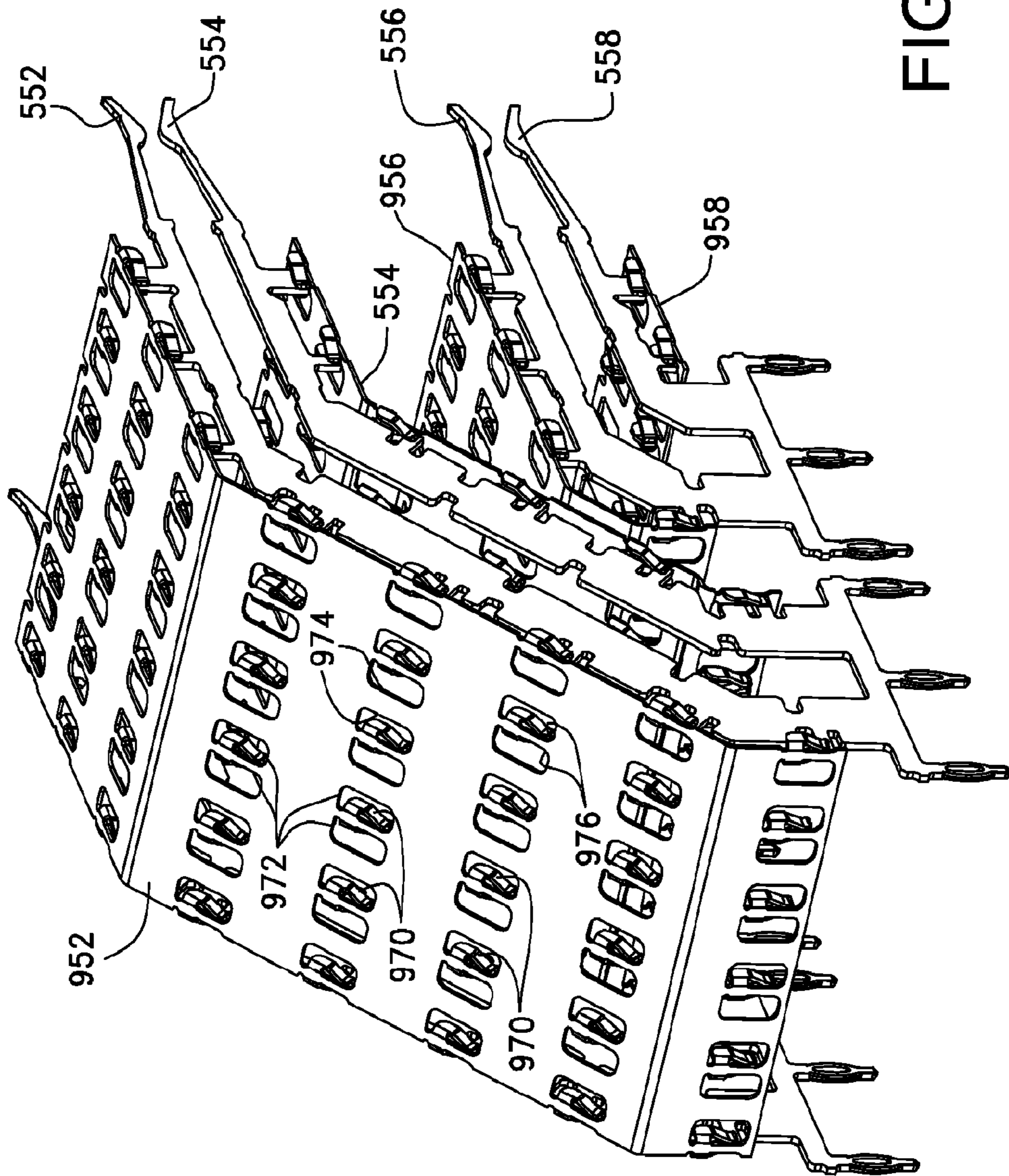

FIG. 36

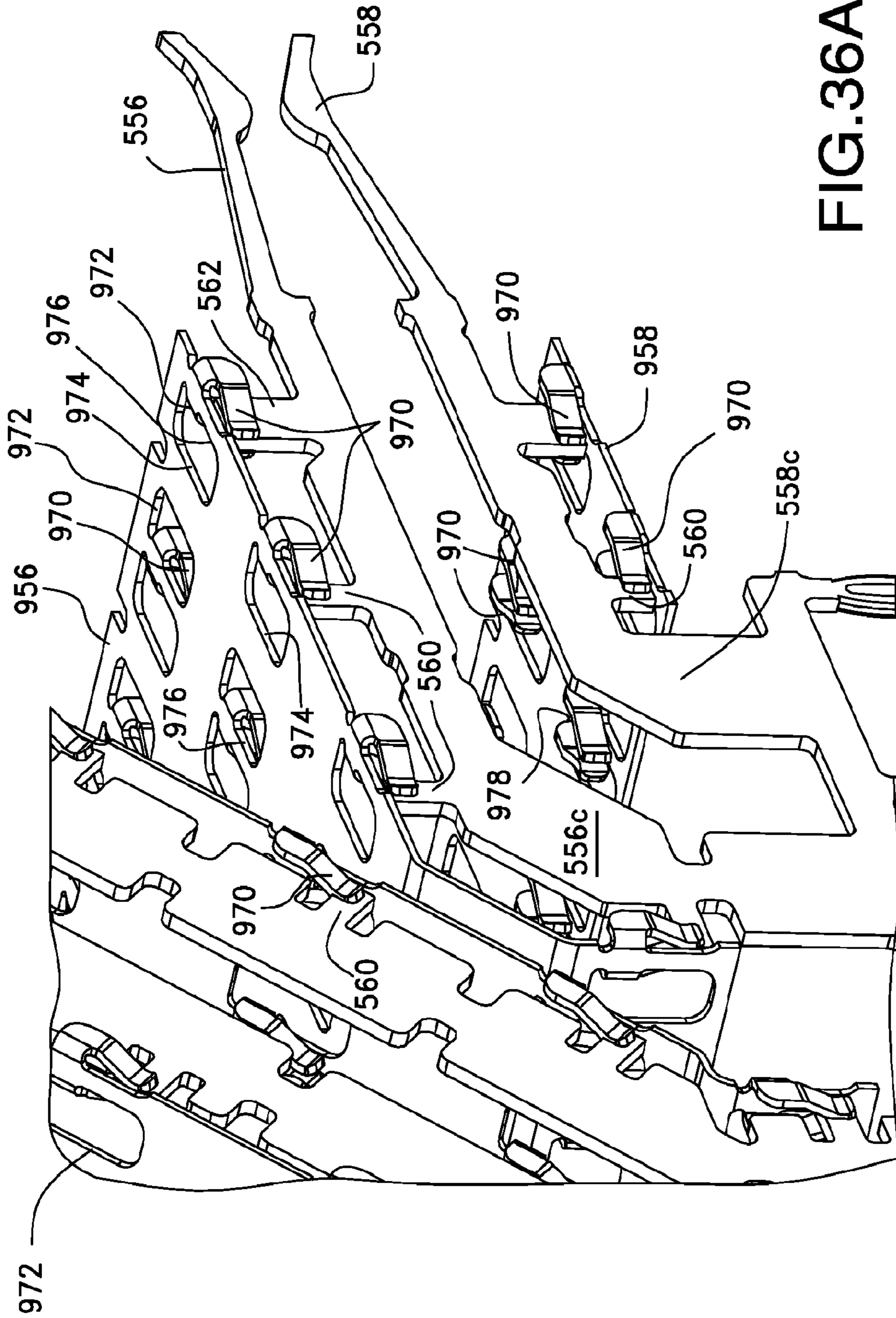

FIG. 36A

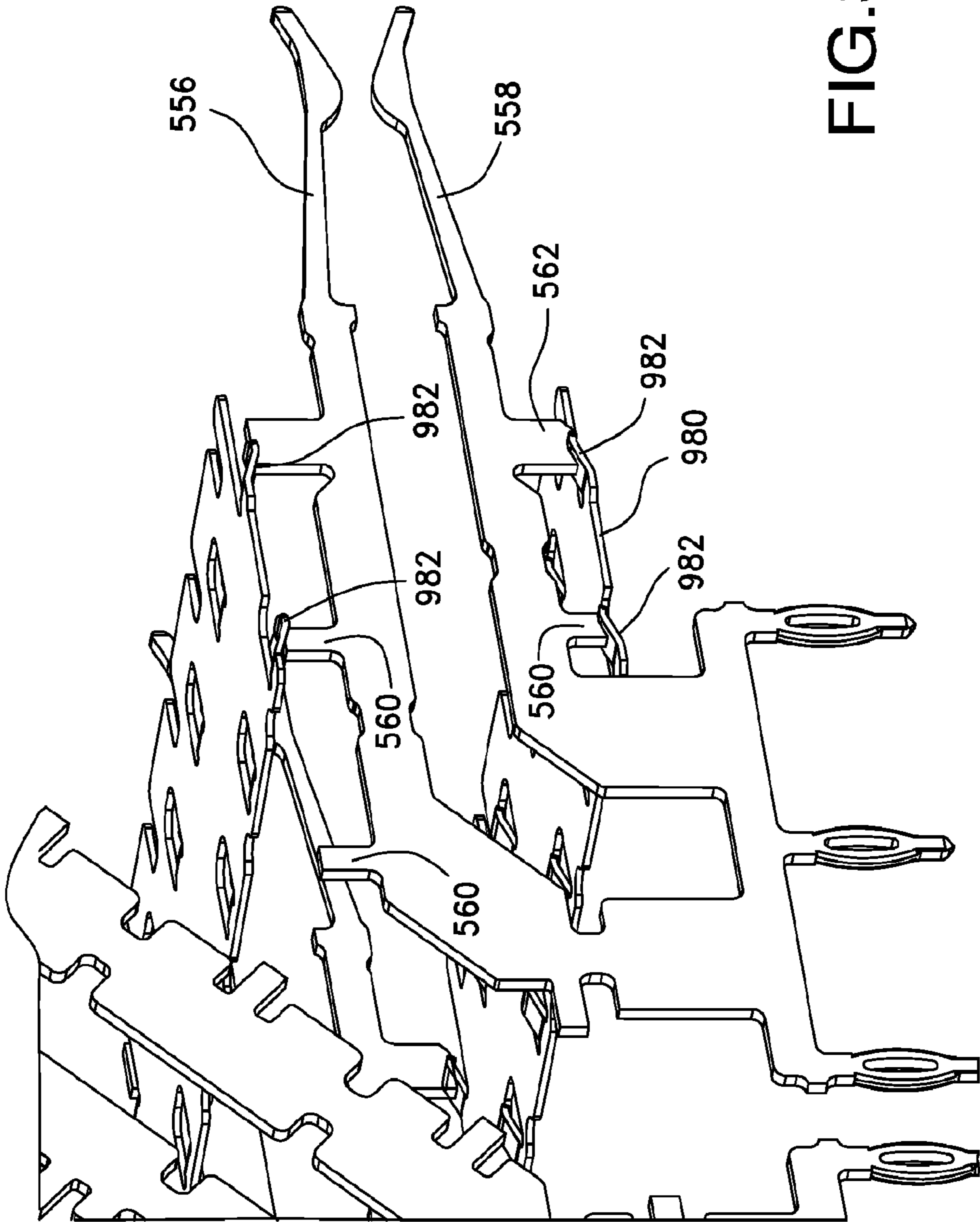

FIG.37

RESONANCE MODIFYING CONNECTOR

RELATED APPLICATIONS

This application is a national phase of PCT Application No. PCT/US09/67333, filed Dec. 9, 2009, which in turn claims priority to U.S. Provisional Appln. Ser. No. 61/122,216, filed Dec. 12, 2008, both of which are incorporated herein by reference in their entirety.

FIELD OF INVENTION

The present invention generally relates to connectors suitable for high data rate communications and, more particularly, to a connector with improved resonance characteristics.

BACKGROUND OF THE INVENTION

While a number of different configurations exist for high data rate connectors, one common configuration is to align a number of terminals in a row so that each terminal is parallel to an adjacent terminal. It is also common for such terminals to be closely spaced together, such as at a 0.8 mm pitch. Thus, high data rate connectors tend to include a number of tightly spaced and similarly aligned terminals.

High data rate communication channels tend to use one of two methods, differential signals or single-ended signals. In general, differential signals have a greater resistance to interference and therefore tend to be more useful at higher frequencies. Therefore, high data rate connectors (e.g., high-frequency capable connectors) such as small form factor pluggable (SFP) style connectors tend to use a differential signal configuration. An increasingly significant issue is that as the frequency of the signals increases (so as to increase the effective data rates), the size of the connector has a greater influence on the performance of the connector. In particular, the electrical length of the terminals in the connector may be such that a resonance condition can occur within the connector if the electrical length of the terminals and the wavelengths of the signals become comparable. Thus, even connector systems configured to use differential signal pairs may experience degradation of performance as operating frequencies increase. Potential resonance conditions in existing connectors tend to make them unsuitable for use in higher speed applications. Accordingly, improvements in the function, design and construction of a high data rate connector assembly is desirable.

SUMMARY OF THE INVENTION

A connector includes a housing that supports a plurality of ground and signal terminals. The terminals can have contact portions, tail portions and body portions extending between the contact and tail portions. The terminals can be positioned in wafers. The signal terminals can be provided as a pair of signal terminals in adjacent wafers that are used as a differential signal pair. A bridge extends between two adjacent ground terminals while extending transversely and not in contact with signal terminals positioned between the ground terminals. If desired, multiple bridges may be used. In one embodiment, the bridge can be a pin that is inserted through multiple wafers and may extend transversely past a plurality of pairs of differential signal pairs. In another embodiment, the bridge can be a series of clips that are positioned in the wafers so as to allow each clip to engage a clip in an adjacent wafer. If the bridge is a pin, the pin can be inserted through a first side of the connector, pass through multiple wafers and

extends to a second side of the connector. While a single bridge can couple three or more ground terminals, in an embodiment a first bridge can be used to couple a first pair of ground terminals and a second bridge can be used to couple a second pair of ground terminals, even if the first and second pair of ground terminals share a terminal. The ground terminals can include translatable arms that are deflected when the bridge engages the ground terminals.

The connector may include a light pipe structure that is supported by the housing. The connector may include a first opening having ground members and signal terminals adjacent thereto so as to provide a first mating plane. The connector may include a second opening having ground members and signal terminals adjacent thereto so as to provide a second mating plane. The housing may be configured to be mounted on a circuit board with the upper surface of the circuit board forming a plane and the plane of the circuit board lying between the first and second mating plane. Alternatively, the connector may be configured so that both mating planes are on the same side of the supporting circuit board.

BRIEF DESCRIPTION OF THE DRAWINGS

Various other objects, features and attendant advantages of the present invention will become more fully appreciated as the same becomes better understood when considered in conjunction with the accompanying drawings, in which like reference characters designate the same or similar parts throughout the several views, wherein:

FIG. 1 is a front perspective view of an embodiment of an electrical connector;

FIG. 2 is an exploded perspective of the connector of FIG. 1 with certain components removed for clarity;

FIG. 3 is a front perspective view of the connector of FIG. 1 with the front housing component removed for clarity;

FIG. 4 is a front perspective view similar to that of FIG. 1 but with both of the front and rear housing components removed in order to show the subassembly of internal wafers;

FIG. 5 is a front perspective view similar to FIG. 4 but with the insulation from around one of the ground wafers removed for clarity;

FIG. 6 is a front perspective view similar to that of FIG. 4 but with the endmost ground wafer removed for clarity;

FIG. 7 is a perspective view similar to FIG. 6 but taken from an orientation somewhat beneath the wafer subassembly;

FIG. 8 is a rear perspective view of the connector of FIG. 1 with the rear housing component removed;

FIG. 9 is a perspective view of the wafer subassembly of FIG. 4 but with all of the insulative components removed for clarity;

FIG. 10 is a view of the subassembly of FIG. 9 but with some of the terminals removed for clarity;

FIG. 11 is a front elevational view of the subassembly of FIG. 10;

FIG. 12 is a sectioned perspective view of FIG. 1 taken generally along line 12-12 of FIG. 1;

FIG. 13 is a side elevational view of a pair of ground terminals of FIG. 12;

FIG. 14 is a side elevational view of an alternate embodiment of the ground terminals depicted in FIG. 13;

FIG. 15 is a side-elevational view of still another alternate embodiment of the ground terminals depicted in FIG. 14;

FIG. 16 is a perspective view of four pairs of signal terminals and one ground terminal associated with each row of signal terminals;

FIG. 17 is a side elevational view of the terminals of FIG. 16 showing the relative widths of the body sections of the signal terminals compared to those of the ground terminals;

FIG. 18 is a perspective view similar to FIG. 9 but showing only the ground terminals and the front bridging structure;

FIG. 18A is an enlarged perspective view of a portion of FIG. 18 showing the interaction between the ground terminals and the front bridging structure;

FIG. 19 is a top plan view of the front bridging structure;

FIG. 20 is a rear elevational view of the electrical connector of FIG. 1 with the rear housing component removed and only two ground and two signal wafers inserted into the front housing component;

FIG. 21 is a rear perspective view of the electrical connector of FIG. 1 but with the rear housing component and insulation around the wafers removed for clarity;

FIG. 21A is an enlarged perspective view of a portion of FIG. 21;

FIG. 22 is a rear perspective view similar to FIG. 21 but with bridging pins inserted;

FIG. 22A is an enlarged perspective view of a portion of FIG. 22;

FIG. 23 is a front perspective view of another embodiment of an electrical connector;

FIG. 24 is a side elevational view of the electrical connector of FIG. 23;

FIG. 25 is a perspective view of the electrical connector of FIG. 23 incorporating a light pipe assembly;

FIG. 26 is a front perspective view of the electrical connector of FIG. 23 but with the front and rear housing components removed in order to show the subassembly of internal wafers;

FIG. 27 is a front perspective view similar to FIG. 26 but with the insulation removed from some of the wafers;

FIG. 28 is a side elevational view of FIG. 27;

FIG. 29 is a perspective view of a subassembly of wafers utilizing an alternate form of grounding clips;

FIG. 30 is a sectioned perspective view of FIG. 29 with the insulation above line 30-30 of FIG. 29 removed for clarity;

FIG. 30A is an enlarged perspective view of a portion of FIG. 30;

FIG. 31 is a perspective view similar to that of FIG. 29 but with the insulation removed from four of the wafers for clarity;

FIG. 32 is a perspective view similar to that of FIG. 30A but depicting only two ground and two signal wafers and with the insulation removed from the wafers for clarity;

FIG. 33 is a perspective view similar to FIG. 32 but of an alternate embodiment of grounding clips;

FIG. 34 is a perspective view similar to FIG. 32 but of another alternate embodiment of ground pins;

FIG. 35 is a front perspective view of an alternate embodiment of a ground terminal bridging structure with only a few ground terminals depicted for clarity;

FIG. 36 is a rear perspective view of the ground bridging structure and ground terminals of FIG. 35;

FIG. 36A is an enlarged perspective view of a portion of FIG. 36; and

FIG. 37 is an enlarged perspective view similar to FIG. 36A but depicting an alternate embodiment of contact arms for the bridging structure.

DETAILED DESCRIPTION OF THE ILLUSTRATED EMBODIMENTS

As required, detailed embodiments are disclosed herein; however, it is to be understood that the disclosed embodi-

ments are merely exemplary and the depicted features may be embodied in various forms. Therefore, specific details disclosed herein are not to be interpreted as limiting, but merely as a basis for the claims and as a representative basis for teaching one skilled in the art to variously employ the disclosed features in virtually any appropriate manner, including employing various features disclosed herein in combinations that might not be explicitly described.

Small form pluggable (SFP) style connectors are often used in systems where an input/output (I/O) data communication channel is desired. A number of variations in SFP-style connectors exist and different connectors are configured to meet different specifications, such as specifications commonly known as SFP, XFP, QSFP, SFP+ and the like. In general, the SFP-style connectors are configured to mate to modules or assemblies having circuit cards therein and include terminals that, at one end, removably mate with pads on the circuit card and, at an opposite end, extend to traces of a circuit board on which the SFP-style connector is mounted.

The details discussed herein, which are based on embodiments of a connector suitable for use with such an SFP-style connector, are not so limited but instead are also broadly applicable to other connector types and configurations as well. For example, without limitation, features of the disclosure may be used for vertical and angled connectors as well as the depicted horizontal connector. In other words, other terminal and housing configurations, unless otherwise noted, may also be used.

In an electrical connector, adjacent terminals, when used to form a high data rate differential pair, electrically couple together to form what can be called a first, or intentional, mode. This mode is used to transmit signals along the terminals that make up the differential pair. However, if other signal terminals are also nearby this differential signal pair, it is possible that one (or both) of the terminals in the differential pair may also electrically couple to one or more of the other terminals (thus forming additional modes). These additional modes are typically undesirable as they can introduce cross-talk that acts as noise relative to the first mode. To prevent such cross-talk, therefore, it is known to shield the differential pair from other signals.

Due to the above-noted tendency to have the terminals located relatively close to each other, pairs of differential signal terminals are often separated from adjacent pairs of differential signal terminals by a ground terminal or a shield. For example, a repeating ground-signal-signal pattern may be used which results in a differential signal pair being surrounded by a ground on each side when the pattern is aligned in a row (e.g., G, S⁺, S⁻, G). A potential issue that arises due to the use of ground terminals as shields is that another mode is created by the coupling between each ground terminal and the pairs of signal terminals. In addition, the difference in voltage between two different grounds can also cause the grounds to couple together as transient signals pass through the connector. These various couplings create additional modes (and resultant electromagnetic fields) and introduce noise from which the first mode must be distinguished if the communication system is going to operate effectively.

The additional modes generally do not cause problems at low data rates as such additional modes tend to operate at higher frequencies and have less power compared to the first mode and thus do not cause a serious noise issue, assuming the connector is otherwise properly designed. However, as the frequency of the data transmission increases, the wavelength of the signal moves closer to the electrical length of the ground terminals. Therefore, at higher frequencies, it is possible that the transmission frequency will be high enough, and

thus the wavelength short enough, to create undesirable resonance in the connector. Such resonance can amplify the secondary modes, which are typically noise, sufficiently to raise the amplitude of the noise as compared to the amplitude of the signal so that it becomes difficult to distinguish between signals and noise. Accordingly, it is desirable for the operating range of a connector to be sufficiently below the resonant frequency of the connector.

As used herein, the term resonant frequency refers to the lowest resonant frequency or fundamental frequency of the connector. Additional resonant frequencies, known as harmonics, exist above the lowest resonant frequency but may generally be ignored since a connector operating within a range below the lowest resonant frequency will also be operating below the harmonics and a connector operating within a range that includes the lowest resonant frequency will likely have issues with respect to noise (absent other steps taken to eliminate or reduce the noise) regardless of whether the operating range also overlaps with any of the harmonics.

The resonant frequency of a connector is a function of the longest effective electrical length between discontinuities or significant changes in impedance along the electrical path which includes the ground terminals. In other words, the resonant frequency depends on the effective electrical length between the points at which two adjacent ground paths are electrically connected. A non-limiting example of such a connection is a ground plane within a circuit board or card to which both of the adjacent ground terminals are connected. It should be noted that the effective electrical length is a function of numerous factors including the physical length of the terminal, the physical characteristics of the terminal (such as its geometry and surrounding dielectric material, both of which affect its impedance) and the physical length and characteristics beyond the terminal (such as within a circuit board) prior to reaching the discontinuity or intersection.

As an example, the physical distance between discontinuities of a pair of ground terminals having tails mounted in a circuit board and contact ends mated to conductive pads on a circuit card would be equal to the physical length of a ground terminal (defined as the distance from the point at which the terminals reach a common ground or reference plane within the circuit board on which they are mounted to the contact ends of the terminals at which they engage the conductive pads of the circuit card) plus the physical length from the conductive pads on the circuit card to a common ground plane within the circuit card. To determine the effective electrical length, which is measured in picoseconds, between discontinuities, one would also need to factor in characteristics that affect the impedance of the circuit path including the physical geometry of the conductors as well as the dielectric medium surrounding the paths.

A connector that can minimize resonance in the relevant frequency range of signaling can provide certain advantages. It has been determined that decreasing the effective electrical length of the ground terminals, which effectively decreases the length between discontinuities, can provide significant benefits in this regard. In particular, decreasing the electrical length of the terminal so that it is not more than one half the electrical length associated with a particular frequency (e.g., the electrical length between discontinuities is about one half the electrical length associated with a wavelength at the $3/2$ Nyquist frequency) has been determined to significantly improve connector performance. It should be noted, however, that in certain embodiments the actual electrical length of the terminal is not the effective electrical length of the connector because there is an additional distance traveled outside the connector before a discontinuity is encountered. For

example, the distance from the edge of the contact of the terminal along a contact pad and through a circuit board until reaching a common ground plane is part of the electrical length between discontinuities. Therefore, a connector with ground terminals that have an electrical length of about 40 picoseconds might, in operation, provide an effective electrical length of about 50 picoseconds between discontinuities once the circuit board and contact pad were taken into account. As can be appreciated, this difference can be significant at higher frequencies as a difference of 10 picoseconds in electrical length could result in a connector suitable for about 20 Gbps performance versus one suitable for about 30 Gbps performance.

As it is often not practicable to shorten or reduce the size of the entire connector, the resonance problem in a differential connector that provides rows of terminals has proven difficult to solve in an economical manner. To address this problem, however, it has been determined that one or a plurality of conductive bridges or commoning members can be used to connect multiple ground terminals so as to shorten the distance between discontinuities, thus reducing the electrical length and raising the resonant frequency. This reduced electrical length permits the establishment of a maximum effective electrical length below a desired level and allows higher frequencies to be transmitted over the connector without encountering resonance within the operating range of the connector. For example, placing a conductive bridge or commoning member so that it couples two ground terminals together at their physical mid-point can reduce the effective electrical length of the ground terminals in the connector approximately in half and therefore raises the resonant frequency by approximately doubling it. In practice, since a bridge has a physical length as it extends between the two ground terminals, placing a bridge at or near the physical midpoint may not reduce the electrical length exactly in half but the reduction can be relatively close to half of the original electrical length.

The features described below thus illustrate embodiment where certain features are used to provide a reduced electrical length. If desired, a connector may be provided having a dielectric housing, a first wafer positioned in the dielectric housing and supporting a first conductive ground terminal and a second wafer positioned in the dielectric housing and supporting a second conductive ground terminal. A pair of signal terminal may be positioned between the first and second ground terminals and at least one conductive bridge may extend between the first ground terminal and the second ground terminal with the conductive bridge electrically connecting the first and second ground terminals and configured so as to provide a reduced maximum effective electrical length of the first and second ground terminals.

If desired, the conductive bridge may be a conductive pin extending through the first and second wafers. Each of the first and second conductive ground terminals may include a contact section at one end for mating with a mating component, a tail at an opposite end for mounting to a circuit member and a generally plate-like body section therebetween. The conductive bridge may be positioned where appropriate and in an embodiment may be positioned so as to electrically connect the first and second ground terminals at a location generally towards a midpoint between the contact ends and the tails of the first and second ground terminals. In one configuration, the reduced maximum effective electrical length of the ground terminals may be less than about 38 picoseconds. In another configuration, the reduced maximum effective electrical length of the ground terminals may be less than about 33 picoseconds. In another configuration, the

reduced maximum effective electrical length of the ground terminals may be less than about 26 picoseconds. The conductive bridge may extend transversely past a plurality of pairs of differentially coupled high data rate signal terminals.

If desired, a method of increasing a resonant frequency of an electrical connector above a desired operational frequency range of the connector may be utilized. Such method includes determining the desired operational frequency range of the connector, and providing first and second spaced apart ground members with the first ground member defining at least part of a first electrical path and the second ground member defining at least part of a second electrical path. A differential signal pair can be provided between the first and second ground members and the approximate maximum effective electrical length between discontinuities along the first and second electrical paths is determined. An initial resonant frequency is determined based on the approximate longest effective length between the discontinuities along the first and second electrical paths and a maximum desired effective electrical length between the discontinuities is determined in order to increase the resonant frequency of the electrical connector above the desired operational frequency range. At least one conductive bridge is connected between the first and second ground terminals to reduce the effective electrical length between discontinuities along the first and second ground members to a length that is less than the maximum desired effective electrical length.

If desired, determining the maximum effective electrical length between discontinuities along the first and second electrical paths may include simulating an electrical system. The simulating step may include analyzing physical characteristics of the ground members including their length, geometry and the dielectric medium surrounding the ground members. The simulating step may include analyzing additional circuit components that define at least part of the first and second electrical paths. Determining the maximum effective electrical length between discontinuities along the first and second electrical paths may include testing the electrical connector.

Referring now to the Figures, FIGS. 1-13 illustrate an embodiment of a connector **500** that includes a first housing component **510** and a second housing component **520**. The first housing component **510** includes a first projection **530** and a second projection **532**, both of which have a card slot **534** configured to receive circuit cards (not shown) that are supported by a corresponding mating module (not shown). As depicted, each card slot **534** includes terminal receiving grooves **536** extending along the top and bottom inner surfaces thereof.

Pin receiving apertures **512** may be provided in a first side **514** of first housing component **510** and pin receiving apertures **516** aligned with pin receiving apertures **512** may be provided in a second side **518** of first housing component **510**. Similarly, pin receiving apertures **522** may be provided in a first side **524** of second housing component **520** and pin receiving apertures **526** aligned with pin receiving apertures **522** may be provided in a second side **528** of second housing component **520**. Depending upon the assembly process used, apertures may not be necessary on both sides of first housing component **510** nor on both sides of housing component **520**. In certain instances, apertures in the first and second housing components may not be necessary at all.

As depicted, the front housing component **510** includes a cavity **540** into which a plurality of insert-molded terminal wafers **550**, **570**, **580** may be inserted. As depicted, each wafer includes two pairs of conductive terminals with a plastic insulative body insert-molded around the terminals. Each

terminal has a contact end for mating with a pad (not shown) on a mating circuit card, at least one tail for engaging a plated hole in a circuit board on which connector **500** is mounted, and a body connecting the contact end and the at least one tail.

More particularly, referring to FIGS. 5, 9, 10, 12, ground wafer **550** includes four ground terminals **552**, **554**, **556**, **558**, each having a mating end **552a**, **554a**, **556a**, **558a** depicted as a deflectable contact beam or spring arm at one end for engaging a mating component (not shown) and tails **552b**, **552b'**, **554b**, **556b**, **556b'**, **558b** depicted as compliant pins for engaging a circuit member (not shown) on which connector **500** is mounted. Relatively large or wide body sections **552c**, **554c**, **556c**, **558c** extend between mating ends **552a**, **554a**, **556a**, **558a** and tails **552b**, **554b**, **556b**, **558b**, respectively, of each terminal. In addition, each ground terminal **552**, **554**, **556**, **558** includes a plurality of deflectable tabs or fingers **560** extending therefrom and a single, relatively wide tab **562** generally adjacent mating end **552a**, **554a**, **556a**, **558a**. If desired, fingers **560** may be slightly angled towards one of the sides of housing components **510**, **520**. A first joining member **564** may be provided between the longer two ground terminals **552**, **554**, and second joining member **566** may be provided between the shorter two ground terminals **556**, **558**.

Signal wafers **570**, **580** can be configured in a substantially similar manner with respect to each other and can be somewhat similar to ground wafers **550**. As depicted in FIGS. 16, 17, each first signal wafer **570** has four signal terminals **572**, **574**, **576**, **578** with a mating end **572a**, **574a**, **576a**, **578a** depicted as a deflectable contact beam or spring arm at one end for engaging a mating component (not shown) and a tail **572b**, **574b**, **576b**, **578b** depicted as a compliant pin for engaging a circuit member (not shown) on which connector **500** is mounted. Relatively small or narrow body sections **572c**, **574c**, **576c**, **578c** extend between mating ends **572a**, **574a**, **576a**, **578a** and tails **572b**, **574b**, **576b**, **578b**, respectively, of each terminal. The difference in width between body sections **572c**, **574c**, **576c**, **578c** of ground terminals **552**, **554**, **556**, **558** and body sections **572c**, **574c**, **576c**, **578c** of signal terminals **572**, **574**, **576**, **578** is best seen in FIG. 17. Signal terminals **572**, **574**, **576**, **578** further include transition sections **572d**, **574d**, **576d**, **578d** between body sections **572c**, **574c**, **576c**, **578c** and tails **572b**, **574b**, **576b**, **578b** in order to offset the tails from the body sections.

Second signal wafer **580** includes four signal terminals **582**, **584**, **586**, **588** that, except as noted below, are substantially identical to the signal terminals **572**, **574**, **576**, **578** of the first signal wafer **570** and the description of which is not repeated herein. However, as can be appreciated from FIG. 11, the tails **572b**, **574b**, **576b**, **578b** of first wafer **570** and the tails **582b**, **584b**, **586b**, **588b** of second wafer **580** are offset from the plane of their respective body sections in opposite directions towards the other wafer so that the tails of the signal terminals of both wafers are aligned in a single row. Upon insertion of the wafers **550**, **570**, **580** into the housing cavity **510a**, the contact sections of the terminals are positioned in and may be supported by the terminal receiving grooves **536** so as to form a row of contact ends. In operation, the row of contact sections facilitates mating between the connector and pads on circuit cards which may be inserted into card slots **534**.

As depicted, the wafers are positioned within cavity **510a** in a repeating pattern with two signal wafers **570**, **580** positioned next to each other to create pairs of horizontally aligned differential-coupled signal terminals. The depicted terminals are broadside-coupled, which has the benefit of provide a stronger coupling between the terminals that form the differential pair, but unless otherwise noted, broadside

coupling is not required. Ground wafers **550** are positioned on both sides of each pair of signal wafers in order to achieve the desired electrical characteristics of the signal terminals and to create a repeating ground, signal, signal, pattern (e.g., G, S⁺, S⁻, G, S⁺, S⁻, G). If desired, other patterns of wafers could be utilized such as adding additional ground wafers (e.g., G, S⁺, S⁻, G, G, S⁺, S⁻, G) to further isolate the signal terminals and/or additional signal wafers could be added in which the addition signal terminals would typically be used for "lower" speed signals (e.g., G, S⁺, S⁻, G, S, S, S, G, S⁺, S⁻, G). In addition, if desired, rather than molding two separate signal wafers **570**, **580** and then position them adjacent to each other during the assembly process, it is also possible that the two signal wafers could be combined so as to provide a single wafer molded around all of the terminals. In addition, if desired, the wafers need not be insert molded. For example, the wafer housing could be molded in a first operation and the terminals inserted into the wafer housing in a second, subsequent operation. Insert molded wafers, however, are beneficial to precisely control the orientation of terminals supported by the wafer.

In order to achieve the desired electrical characteristics, the depicted embodiment illustrates a connector with pins **600** (e.g., the pins providing the electrically conductive bridges) to be inserted once wafers **550**, **570**, **580** are loaded into the first and second housing components **510**, **520**. The pins **600** engage and deflect fingers **560** of the ground terminals to couple together multiple ground terminals and thus form electrically conductive bridges. More particularly, as best seen in FIG. 9, a first pin **600a** engages a first set of aligned fingers **560'** of ground terminals **552**, a second pin **600b** engages a second set of aligned fingers **560''** of ground terminals **552**, and this can be repeated with additional pins so that ground terminals **552** are interconnected or commoned at multiple locations. It should be noted that the fingers **560** may be somewhat deflected out of the plane of the body section of each ground terminal but, for clarity, such deflection is not shown in the drawings.

The bridges (depicted as pins **600** in FIGS. 1-28) couple fingers **560** that extend from the body portions **552c**, **554c**, **556c**, **558c** of the ground terminals **552**, **554**, **556**, **558**. It has been determined that for a multi-row connector design, the height of the connector and the length of the ground terminals make the inclusion of a number of bridges desirable so as to ensure the effective electrical length is short enough. The pins **600** may be formed of a sufficiently conductive material such as a copper alloy with a desirable diameter, such as between 0.4 mm and 0.9 mm. It has been determined that such a construction allows for a pin **600** that has sufficient strength to allow for insertion while avoiding any significant increase in size of the connector. As can be appreciated, a shorter connector may be able to provide ground terminals with a desirable electrical length while only using one bridge. It is expected, however, that a plurality of bridges will be beneficial in many connector configurations.

For connector with multiple rows of contacts, such as those depicted, the terminals have different lengths, depending on the row in which they are positioned. Consequentially, a different number of bridges can be used with each row of ground terminals to ensure the corresponding row of ground terminals has the desired maximum electrical length. For example, in FIG. 4, the top row of ground terminals **552** in the first projection **530** is coupled to seven pins **600** while the opposing row of ground terminals **554** is coupled to five pins **600**. The top row of ground terminals **556** in the second projection **532** is coupled to three pins **600** while the opposing row of ground terminals **558** is coupled to one pin **600**. Thus,

in the depicted embodiment, the number of pins in subsequent lower rows decreases by two as compared to the prior upper row. This helps ensure a desirable performance while minimizing complexity and cost.

The bridges extend transversely across the signal terminals, such as terminals **572**, **582** that form the differential pair **540** (FIG. 11). To minimize electrical interference and changes in impedance, each bridge may be positioned a distance **588** from the upper surface of the signal terminals **572**, **582**. In an embodiment, the distance between the bridge and the terminals **572**, **582** that form differential pair **540** is sufficient so that there is greater electrical separation between the bridge and the differential pair **540** than there is between the two terminals that form the differential pair.

As described above, the pairs of upper and lower ground terminals **552**, **554** in the first projection **530** may be coupled by a first joining member **564** proximate to ground tails **552b**, **554b** and the pairs of upper and lower ground terminals **556**, **558** in the second projection **532** may be coupled by second joining member **566** proximate to ground tails **555b**, **558b**. These joining members can help further reduce potential differences between ground terminals and improve the overall performance of connector **500**. As can be appreciated from FIGS. 13-15, alternative embodiments of the ground terminals may be provided such as enclosing the space between the body sections **552c**, **554c** of ground terminals **552**, **554** to create a single ground terminal body **552c'** to shield both of the signal terminals **572**, **574** in the upper and lower rows of first projection **530**. Such a terminal could include fingers **560** extending from the upper and lower edges of the body or might include fingers **560'''** extending from only one side (such as depicted in FIG. 14) or could include pins **600** extending through the middle of the ground terminals with an interference fit (as depicted in FIG. 15).

Referring to FIG. 19, an embodiment of a bridge is illustrated. The bridge is provided by a clip **630** which is inserted into the first housing component **510** prior to insertion of wafers **550**, **570**, **580**. The clip **630** is conductive and may be once piece as shown. The clip **630** can include a plurality of spaced apart engagement notches **631** that engage projections on first housing component **510** so that the first housing component **510** retains the clip **630** therein with a press-fit type engagement. The clip **630** includes a plurality of spaced apart receiving channels **632**, which can be on an edge opposite notches **631**, with each channel having a pair of opposing spring arms **633** therein. As depicted, the distance between spring arms **633** is less than the thickness of wide tab **562** in order to establish a good electrical connection between the spring arms **633** and wide tab **562** upon insertion of wide tab **562** between spring arms **633**. If desired, a bump or projection **634** may be provided on each spring arm **633** in order to increase the reliability of the contact between the spring arms and the wide tab.

Clip **630** is preferably formed of an appropriate conductive material having sufficient spring and strength qualities so as to reliably retain clip **630** within front housing component **510** and maintain a reliable connection between spring arms **633** and wide tabs **562**. It may be desirable to use clip **630** in situations in which it is difficult to insert a pin **600** near the mating ends **552a**, **554a**, **556a**, **558a** of ground terminals **552**, **554**, **556**, **558**. Depending on the available space within the connector **500**, channels **632** may be omitted from the outer lateral edges of clip **630** and replaced by a single spring arm **633** in which case the wide tabs of the outer ground wafers will only be engaged by a single spring arm **633**. Although clip **630** is depicted in FIGS. 1-28 as a one-piece member, if

desired, clip 630 could be formed of multiple components 890 (FIGS. 29-34) that are secured within front housing component 510.

During the assembly process, the wafers supporting the terminals may be inserted into the housing in a number of different manners. Some examples of the assembly process include: 1) individually loading or stitching the wafers into the housing in the sequence in which they are aligned in the housing (e.g., G S⁺S⁻G S⁺S⁻G); 2) inserting all of the wafers of a first type (e.g., all of the ground wafers 550) into cavity 540, inserting all of the wafers of a second type (e.g., all of the first signal wafers 570) into cavity 540 and this process repeated until the cavity is fully populated; 3) configuring the wafers carrying the signal terminals so that the two signal wafers 570, 580 are coupled together first and then inserting the coupled wafer pair into the housing; or 4) coupling or positioning all of the wafers together in the desired pattern and then inserting the coupled subassembly of wafers into cavity 540 in a single loading operation.

For the first three assembly processes listed above, after the wafers 550, 570, 580 have been inserted into first housing 510, pins 600 can be inserted into connector 500. If the fingers 560 are all co-planar with body sections 552c, 554c, 556c, 558c, pins 600 may be inserted from either side of the connector. More specifically, pins 600 could be inserted through the pin receiving apertures in either side of first housing component 510 and through the pin receiving apertures in either side of second housing component 520. If desired, the pins 600 may extend essentially the entire width of connector 500 and through the pin receiving apertures on both sides of first housing component 510 and second housing component 520.

As described above, fingers 560 may be slightly angled toward one of the sides of the respective first and second housing components 510, 520 and away from the direction of insertion of the pins 600 in order to ease insertion of the pins. As can be appreciated, in such case, it is preferable that the fingers 560 are all angled in the same direction (e.g., toward the same side) and the pins 600 could be inserted from the side opposite the side towards which the fingers are angled. In other words, fingers 560 may be bent out of the plane of the body section of their respective ground terminal and pins 600 can be inserted in the same direction as the fingers extend out of the plane of the body section.

If wafers 550, 570, 580 are coupled or positioned together in the desired pattern and then inserted as a subassembly of wafers into cavity 540 in a single loading operation as described above as the fourth assembly process, pins 600 could be inserted as described above once the wafer subassembly has been inserted into cavity 510a and second housing component 520 secured to first housing component 510. In the alternative, shorter pins that only extend between the opposite sides of the wafer subassembly and not through the sidewalls of first or second housing components 510, 520 could be inserted into the wafer subassembly prior to insertion of the subassembly into first housing wafer 510. In other words, the wafer subassembly may be joined by the pins and the entire subassembly inserted as a group into cavity 510a. In such case, apertures in the first and second housing components 510, 520 would not be necessary.

Regardless of which assembly process is used, if first housing component 510 includes a clip 630, during insertion of ground wafers 550, the wide tab 562 of each ground terminal 552, 554, 556, 558 will slide into a receiving channel 632 and between spring arms 633 in order to establish a good electrical connection between clip 630 and one of the ground terminals 552, 554, 556, 558. In other words, in an embodiment

the clip can be first inserted into the housing component 510 and then the wafers can be inserted in the housing component 510 so that the ground terminals engage the clip 630.

Referring to FIGS. 23-28, an embodiment of a connector 700 is depicted that is similar to that of FIGS. 1-22A except that the seating plane 702 (i.e., the plane of the circuit board on which the connector is mounted) has been moved upward so that the plane of one of the circuit card slots (lower slot 732 as depicted) is positioned below the plane of upper surface 52 of the circuit board 50. Connector 700 includes a housing 710 with a first surface 712, a first side 716 and second side 718. Apertures 714 in the first side allow pins 740 to be inserted into the connector 700. Projection 726, which includes first surface 727 and second surface 728, includes two vertically spaced apart card slots 730, 732 therebetween. The card slots 730, 732 may be chamfered and include terminal receiving grooves 734 for supporting terminals 750 inserted therein.

The sides of the connector 700 may include a curved wall 713 configured to retain a light pipe and may further include a shoulder 720 to help support the light pipe. If desired, a front face 729 of projection 726 may include apertures, such as aperture 736, to support a light pipe assembly 738. Slots 740 may be used to support shielding members (not shown).

The depicted housing 710 includes a block 722 that extends past an edge 54 of the circuit board 50 while the upper surface 52 of the circuit board 50 supports the connector. As can be appreciated, the depicted connector, while providing a press-fit (or thru-hole) mounting interface with respect to the circuit board, also allows the lower circuit card slot 732 to be positioned below the upper surface 52 of the circuit board. Thus, the depicted embodiment provides an advantageously compact and low profile package.

As with connector 500, connector 700 includes an alternating array of wafers 745, 746, 747. Wafers 745, 746, 747 are similar in construction to wafers 550, 570, 580 except that the seating plane 702 of connector 700 has been moved as compared to the seating plane of connector 500. In addition, ground wafer 745 is different from ground wafer 550 in that it includes both ground terminals and signal terminals therein. More specifically, as best seen in FIGS. 27, 28, ground wafer 745 includes four terminals with the topmost and bottommost terminals 751, 752 being configured as ground terminals with wide body sections 751c, 752c and resilient tabs or fingers 756 extending therefrom. The middle two terminals 762, 764 are configured in a manner similar to the signal terminals 755 with the body sections 762c, 764c thereof being substantially narrower than the body sections 751c, 752c of the ground terminals.

As depicted, a first row 770 of terminals includes a plurality of pairs of differentially coupled high data rate signal terminals 771 with ground terminals 751 on opposite sides of each pair. Pins 780 engage fingers 756 of ground terminals 751 to common the ground terminals as described above in order to provide a desired maximum effective electrical length. A second row 772 of terminals 762 within the first card slot 730 has a similar configuration but does not include high data rate terminals and commoned ground terminals and thus the upper card slot 730 (which includes the first and second rows 770, 772) is configured for a high data rate version of the SFP-type connector (as SFP-style connectors include two high data rate channels in one of the two rows). The second card slot 732 is configured in a manner that is similar to the first card slot 730 as it has a third row 774 of terminals 764 not including commoned ground terminals while a fourth row 776 of terminals includes a pair of differentially coupled high data rate signal terminals 778 with commoned ground terminals 752 on opposite sides of each pair. Thus, both the first and second

card slots **730**, **732** are suitable for use in a high data rate variant of a SFP connector but the second card slot is rotated 180 degrees with respect to the orientation of the high data rate terminals surrounded by commoned ground terminals. Terminals **762**, **764** of the middle two rows of terminals can be used as desired for lower-speed signals and/or power or the like. In an embodiment, the high data-rate terminals rows may be configured so that they are suitable for 17 Gbps performance or even 20 or 25 Gbps. As can be appreciated, flipping the orientation of the second card slot with respect to the first card slot is advantageous from a standpoint of signal separation in a dense package but is not required.

FIGS. **29-32** illustrate a subassembly of wafers similar to that of FIGS. **1-22A** but which include an alternate embodiment of a structure for bridging the ground terminals in the wafers. Accordingly, like reference numbers are used with respect to like elements and the description of such elements is omitted. Wafers **850**, **870**, **880** include apertures **810** there-through in which individual conductive, identically shaped, resilient ground clips **812**, **814** are positioned. Ground clips **812**, **814** may be inserted into apertures **810** either before or after molding of the plastic insulation around wafers **850**, **870**, **880**. The ground clips **812**, **814** are configured to extend slightly beyond at least one side surface of its respective wafer so that each clip engages the clips on opposite sides thereof. In addition, the ground clips **812** associated with each ground wafer **850** also engage a tab **816** extending away from body section **552c**, **554c**, **556c**, **558c** of the ground terminals **552**, **554**, **556**, **558**. Wafers **870**, **880**, which include the high data rate signal terminals, are positioned between two ground wafers **850** so that grounding clips **814** of the signal wafers engage the grounding clips **812** of the ground wafers and form a continuous electrical bridge that extends between ground terminals and transversely to and spaced from an edge of the high data rate signal terminals.

As best seen in FIG. **32** due to the removal of the plastic insulation of wafers **850**, **870**, **880**, the individual ground clips **812** secured within each ground wafer **850** conductively engage a tab **816** associated with each ground terminal **552**, **554**, **556**, **558**. However, the individual ground clips **814** secured within each signal wafer **870**, **880** are spaced from the edge of the closest signal terminal by a sufficient distance (similar to distance **588** of FIG. **11**) so as to avoid electrical interference and impedance affects on the signal terminals. The grounding clips may be formed of sheet metal or another resilient conductive material and, as depicted, are generally U-shaped or oval-shaped.

When the wafers **850**, **870**, **880** are assembled, the ground clips **812**, **814** combine to serve the same purpose as pins **600**, namely, to interconnect the adjacent ground terminals along the length thereof in order to reduce the electrical length between discontinuities along the ground terminals. Thus, as with the embodiment of FIGS. **29-32**, grounding clips **812**, **814** permit the ground terminals **552**, **554**, **556**, **558** to have a maximum effective electrical length that is substantially shorter than the effective electrical length of the terminals.

Referring to FIG. **33**, another embodiment of individual ground clips is disclosed. As with ground clips **812**, **814** discussed above, ground clips **820**, **822** are identically shaped, resilient conductive members and may be formed of conductive sheet metal. Ground clips **820**, **822** are similar in shape to ground clips **812**, **814** except that they include an internal resilient, relatively small U-shaped section so that clips **820** may resiliently and conductively engage tabs **824** of the ground terminals.

In another embodiment, the resilient ground clips **812**, **814** may be replaced by cylindrical posts **830** (FIG. **34**) that are

retained within each wafer **850**, **870**, **880**. Upon assembling the wafers side-by-side, the posts **830** will combine to resemble pins **600**. In other words, if desired, pins **600** may be formed of multiple components rather than utilizing a one-piece construction.

FIGS. **35-36A** illustrate a subassembly of ground terminals that utilize an alternate embodiment of a structure for electrically bridging such terminals. The ground terminals are similar to those shown in FIG. **10** and like reference numbers are used with respect to like elements and the description of such elements is omitted. Comparing FIG. **35** to FIG. **10**, it can be seen that all of signal terminals and all but a few of the ground terminals have been removed for clarity. More specifically, all of the terminals of FIG. **10** have been removed except for those on the outer ends of the terminal array. A plate-like bridging structure is associated with each row of ground terminals. An upper row of ground terminals **552** has a first plate-like bridging structure **952** associated therewith, a second row of ground terminals **554** has a second plate-like bridging structure **954** associated therewith, a third row of ground terminals **556** has a third plate-like bridging structure **956** associated therewith and a lower row of ground terminals **558** has a fourth plate-like bridging structure **958** associated therewith. Each of the three upper bridging structures **952**, **954**, **956** are shaped as bent plates formed with multiple, interconnected, generally planar segments while the fourth bridging structure **958** is generally planar.

Each bridging structure includes a plurality of pairs of spaced apart, opposed resilient spring arms **970** positioned in a three-dimensional array and aligned with fingers **560** of each ground terminal. Each arm **970** is formed by stamping and forming the sheet metal so as to create the downwardly depending resilient arms and creating a window **972** in the sheet metal. While not shown, each signal contact is generally aligned with one of the edges **974** of window **972** opposite the edge **976** from which the spring arm depends. Each arm **970** is shaped so as to taper inward towards its opposing arm in order to create an enlarged inlet **978** to facilitate insertion of finger **560** into engagement with each pair of arms. Upon insertion of finger **560**, spring arms **970** deflect outward in a direction generally perpendicular to the plane of the body sections of the ground terminals.

FIG. **37** depicts an alternate embodiment of a plate-like bridging structure **980** in which each pair of spring arms **970** is replaced by a single spring arm **982** that is deflectable in a direction generally perpendicular to the plane of the segment of the bridging structure from which it depends. In other words, the single spring arms **982** are configured and positioned so as to be aligned with fingers **560** and deflect in the direction that each finger **560** extends away from its ground terminal.

As depicted, the bridging structures **952**, **954**, **956**, **958**, **980** are formed of sheet metal so as to have the desired electrical and mechanical characteristics. It should be noted that with respect to the embodiment depicted in FIGS. **35-37**, fingers **560** were formed so as to be resilient and deflect to some extent upon engagement by pins **600**. Since the spring arms **970**, **982** of the plate-like bridging structures are resilient, it is not necessary for fingers **560** be resilient when used with the plate like bridging structures depicted herein.

It should be noted that, in general, the longest section of the ground path between discontinuities will tend to control the resultant resonant frequency. Therefore, an electrical path that has a number of closely spaced bridges to create a series of short electrical lengths between discontinuities while also having a longer section between discontinuities will have an effective electrical length determined by the longer section

between discontinuities. Consequently, it is beneficial to ensure that the maximum or longest effective electrical length between discontinuities is below or less than a predetermined length.

When designing a high data rate connector, a desired operational frequency range of the connector is typically known. Once the designer has designed a connector (or obtained a pre-existing connector), the connector can be analyzed to determine a maximum effective electrical length between discontinuities along adjacent ground paths in which the connector will be used. While this length is primarily the electrical length of the ground terminals, other factors contribute to the effective electrical length including any distance along the circuit path outside of the connector prior to reaching a discontinuity as well as other factors that affect the characteristics of the conductors.

Based upon the maximum effective electrical length between discontinuities, an initial or unmodified resonant frequency can be determined. If the initial or unmodified resonant frequency is too low (which means that the operational range of the connector will overlap with the resonant frequency), a maximum desired effective electrical length is determined such that the resonant frequency for such effective length will be sufficiently above the desired operational frequency range of the connector. At that point, one or more conductive bridges, such as those incorporating the structures disclosed herein, may be used to interconnect adjacent ground members and reduce the effective electrical length between discontinuities to a length less than the maximum desired effective length and thus increase the resonant frequency of the ground structure of the connector. In the alternative, the maximum desired effective length could be determined (based upon a desired resonant frequency) prior to determining the maximum effective electrical length between discontinuities. It should be noted that analyzing the connector to determine the longest effective electrical length between discontinuities and the desired maximum electrical length can be performed either by simulation of the circuitry or by actual measurement if physical samples of the connector exist.

It has been determined that a stacked SFP type connector with ground terminals that have an effective electrical length of about less than 38 picoseconds is suitable for use with signaling frequencies of about 8.5 GHz, which should provide about a 17 Gbps connector per differential signal pair when using a non-return to zero (NRZ) signaling method.

Careful placement of the bridges may allow the effective electrical length of the ground terminals to be reduced to about 33 picoseconds, which may be suitable for signaling frequencies of about 10 GHz (and thus may be suitable for about 20 Gbps performance). If the bridges are configured to be even closer together physically, the effective electrical length can be reduced to about 26 picoseconds, which may be suitable for transmitting signals at about 13 GHz or 25 Gbps performance (assuming NRZ signaling methodology). As can be appreciated, therefore, spacing the bridges closer together (and thus increasing the number of bridges) will have the tendency to reduce the effective electrical length of the ground terminals and consequentially help make the connector more suitable for higher frequencies and higher data rates. The desired maximum effective electrical length will vary depending on the application and the frequencies being transmitted.

In an embodiment, the connector can be configured so as to reduce the effective electrical length of a plurality of ground terminals so as to shift the resonant frequency sufficiently, thereby providing a substantially resonance free connector up

to the Nyquist frequency, which is one half the sampling frequency of a discrete signal processing system. For example, in a 10 Gbps system using NRZ signaling, the Nyquist frequency is about 5 GHz. In another embodiment, the maximum electrical length of a plurality of ground connectors may be configured based on three halves (3/2) the Nyquist frequency which, for a 10 Gbps system is about 7.5 GHz, for a 17 Gbps system is about 13 GHz and for a 25 Gbps system is about 19 GHz. If the maximum electrical length is such that the resonance frequency is shifted out of the 3/2 Nyquist frequency range, a substantial portion of the power transmitted, potentially more than 90 percent, will be below the resonant frequency and thus most of the transmitted power will not cause a resonance condition that might otherwise increase noise within the system.

It should be noted that the actual frequency rate and effective electrical lengths vary depending upon the materials used in the connector, as well as the type of signaling method used. The examples given above are for the NRZ method, which is a commonly used high data rate signaling method. As can be appreciated, however, in other embodiments two or more ground terminals may be coupled together with a bridge at a predetermined maximum electrical length so that the connector is effective in shifting the resonance frequency for some other desired signaling method. In addition, as is known, electrical length is based on the inductance and capacitance of the transmission line in addition to the physical length and will vary depending on geometry of the terminals and materials used to form the connector. Thus, similar connectors with the same basic exterior dimensions may not have the same effective electrical length due to construction differences.

It will be understood that there are numerous modifications of the illustrated embodiments described above which will be readily apparent to one skilled in the art, such as many variations and modifications of the resonance modifying connector assembly and/or its components, including combinations of features disclosed herein that are individually disclosed or claimed herein, explicitly including additional combinations of such features, or alternatively other types of signal and ground contacts. For example, bridging structures can be used with arrays of signal and ground terminals regardless of whether the terminals are positioned in wafers that are inserted into a housing or the terminals are inserted directly into a housing. In addition, if the signal terminals are configured as differential pairs, they may be broad-side or edge coupled. Also, there are many possible variations in the materials and configurations. For example, components that are formed of metal may be formed of plated plastic provided that the necessary mechanical and electrical characteristics of the components are maintained. These modifications and/or combinations fall within the art to which this invention relates and are intended to be within the scope of the claims, which follow. It is noted, as is conventional, the use of a singular element in a claim is intended to cover one or more of such an element.

The invention claimed is:

1. A connector, comprising:

- a housing providing a card-receiving slot, the card-receiving slot having two sides;
- a first wafer positioned in the housing and supporting a first ground terminal and a second ground terminal;
- a second wafer positioned in the housing and supporting a third ground terminal and a fourth ground terminal, wherein each of the ground terminals include a contact, a tail and a body extending therebetween, the contacts of the first and second ground terminals configured to

deflect in opposite directions and the contacts of the third and ground terminals configured to deflect in opposite directions;

a third and fourth wafer positioned between the first and second wafers, the third and fourth wafer each supporting a first signal terminal and a second signal terminal, wherein each of the signal terminals includes a contact, a tail and a body extending therebetween, the contacts of the first and second signal terminal configured to deflect in opposite directions, the first signal terminals of the third and fourth wafers defining a first differential pair and the second signal terminals of the third and fourth wafers defining a second differential pair, the first differential pair positioned between the first and third ground terminals such that the bodies of the first signal terminals and the first and third ground terminals are in a first row and the second differential pair positioned between the second and fourth ground terminals such that the bodies of the second signal terminals and the second and fourth ground terminals are in a second row, wherein the contacts of the first and third ground terminals and the first signal terminals are positioned in a horizontal line to provide a ground, signal, signal, ground configuration and positioned on one of the two sides of the card-receiving slot and configured to deflect in a first direction and the contacts of the second and fourth ground terminals and the second signal terminals are positioned in a horizontal line in a ground, signal, signal, ground configuration on the other of the two sides of the card-receiving slot and configured to deflect in a second direction that is opposite the first direction; and a bridge extending between the first ground terminal and the third ground terminal, the bridge electrically connecting the first and third ground terminals and electrically insulated from the signal terminals, the bridge configured to provide the first and second ground terminals with an maximum effective electrical length.

2. The connector of claim 1, wherein the bridge is a conductive pin extending between the first wafer and the second wafer and passing through the third and fourth wafer.

3. The connector of claim 1, wherein the ground and signal terminals each have a body section and the body section of the ground terminals is wider than the body section of the signal terminals where the bridge is positioned.

4. The connector of claim 1, wherein the maximum effective electrical length of the ground terminals is less than about 38 picoseconds.

5. The connector of claim 1, wherein the maximum effective electrical length of the ground terminals is less than about 26 picoseconds.

6. The connector of claim 1, further comprising a fifth wafers that supports a ground terminal, wherein the bridge electrically couples the ground terminal in the first, second and fifth wafer.

7. The connector of claim 1, wherein the bridge is a first bridge, the connector further comprising a second bridge coupling the first and second ground terminal, the first and second bridge spaced apart so as to provide the ground terminals with a desired electrical length between the first and second bridge.

8. The connector of claim 1, wherein the bridge comprises a clip positioned in each of the wafers, the clip in electrical contact with the ground terminal and electrically separated from the signal terminals.

9. The electrical connector of claim 1, further including a fifth and sixth wafer that are configured similar to the third and fourth wafer and including a seventh wafer configured

similar to the first wafer, the fifth and sixth wafer positioned between the second wafer and the seventh wafer, wherein the bridge extends transversely past two pairs of terminals that are configured to provide a differential signal pair and the bridge is electrically connected to at least one ground terminal on each side of each differential pair.

10. An electrical connector comprising:

a dielectric housing with a first and second sidewall;

a pair of ground terminals positioned within the housing;

a pair of signal terminals positioned within the housing between the ground terminals that make up the pair of ground terminals, wherein each terminal includes a contact section at one end configured for making an electrical connection to a mating component, a tail at an opposite end, and a body section positioned between the contact section and the tail, the contact sections of the pair of ground terminals and the pair of signal terminals forming a row of contacts sections that extends in a first direction, the row of contacts sections in a ground, signal, signal, ground configuration, the contacts sections configured to deflect in a second direction substantially perpendicular to the first direction; and

a bridge electrically connecting the pair of ground terminals together, wherein the body of each of the ground and signal terminals is aligned in a line so that the bridge extends transversely to the signal terminals.

11. The electrical connector of claim 10, wherein the bridge is selected from group consisting of a conductive pin and a plurality of conductive clips.

12. The electrical connector of claim 11, wherein the bridge is the conductive pin and the conductive pin extends through the first sidewall.

13. The electrical connector of claim 10, wherein the pair of ground terminals is a first pair of ground terminals, the connector further including a second pair of ground terminals, the bridge electrically coupling the first and second pair of ground terminals.

14. The electrical connector of claim 13, wherein the first pair of ground terminals includes a first ground terminal and a second ground terminal and the second ground pair comprises the second ground terminal and a third ground terminal.

15. The electrical connector of claim 14, wherein the bridge electrically interconnects the first, second and third ground terminal.

16. The electrical connector of claim 10, wherein each ground terminal includes a projection extending from the body section and the bridge engages the projection.

17. The electrical connector of claim 16, where the projection includes a deflectable arm configured to engage the bridge.

18. The electrical connector of claim 10, wherein the body section of the pair of signal terminals has a first width at the point where the bridge extends transverse to the signal terminals and the body section of the pair of ground terminals has a second width at the point where the bridge is coupled to the ground terminals, the second width being greater than the first width.

19. The electrical connector of claim 10, further including a plurality of ground wafers and at least one signal wafer, each ground wafer supporting one of the ground terminals and the at least one signal wafer supporting the signal terminals, the ground and the at least one signal wafer arranged in a subassembly of wafers.

20. The electrical connector of claim 19, wherein the bridge extends through the at least one signal wafer positioned between adjacent ground wafers.

19

21. The electrical connector of claim 19, wherein the bridge is a first bridge, the connector further comprising a second bridge, the second bridge extending through the ground wafers to electrically connect the ground terminals within adjacent ground wafers, the combination of the first and second bridge causing a maximum effective electrical length of the ground terminals to be shorter than if just the first bridge were used.

22. The electrical connector of claim 10, further including a light pipe configured to direct light toward a mating face of the connector.

23. The electrical connector of claim 10, wherein the connector includes a first opening having ground members and signal terminals adjacent thereto and forming a first mating plane, the first opening configured to receive a portion of a first mating component, and a second opening having ground members and signal terminals adjacent thereto and forming a second mating plane, the second opening being configured to receiving a portion of a second mating component, the first and second mating planes being spaced apart and substantially parallel to each other.

24. The electrical connector of claim 10, wherein the pair of signal terminals is configured to provide a differential signal pair that is broad-side coupled.

25. An electrical connector comprising:

a housing;

a first insert-molded ground wafer and second insert-molded ground wafer each supporting a plurality of ground terminals, the ground wafers not supporting signal terminals;

a first insert-molded signal wafer and a second insert-molded signal wafer, each of the insert-molded signal wafers supporting a plurality of signal terminals, the first and second signal wafer cooperatively providing a pair of differentially-coupled signal terminals, wherein the first and second ground wafer and the first and second signal wafer provide at least two rows of terminals; and

a bridge extending through the first and second signal wafer and electrically connecting one of the ground terminals in the first ground wafer to one of the ground terminals in the second ground wafer, the bridge extending transversely to the differentially coupled signal terminals.

20

26. The electrical connector of claim 25, wherein the ground terminals electrically connected together by the bridge are configured to provide a maximum electrical length between discontinuities of not more than 33 picoseconds.

27. The electrical connector of claim 25, wherein the bridge is a first bridge, the connector comprising a plurality of additional bridges, the bridges configured to provide a maximum electrical length between discontinuities of not more than 26 picoseconds.

28. The electrical connector of claim 25, wherein the ground terminals each include a finger extending from the body, the finger electrically connected to the bridge, wherein the bridge is a pin and the pin causes the finger to deflect.

29. An electrical connector comprising:

a housing with a card slot, the card slot including a first and second side;

a plurality of wafers supported by the housing, each of the wafers having first and second terminals supported by an insulative structure, the wafers being formed in an insert-molded process, the first terminals having a contact that extends into the card slot on the first side and the second terminals having a contact that extends into the card slot on the second side, the contacts of the first and second terminals positioned in first and second rows, respectively and cantilevered from the insulative structure such that they can deflect, the contacts of the first and second terminals configured, in operation, to deflect in opposite directions when mated to a mating connector, the first terminals configured in a ground, signal, signal, ground configuration and each including a body that is configured so that the first four terminals are substantially aligned, the ground terminals in the ground, signal, signal, ground configuration including a finger that extends from the body; and

at least one bridge that extends transversely through the wafers, the bridge electrically isolated from the signal terminals and in contact with the fingers so as to electrically connect the two ground terminals on opposing sides of the two signal terminals.

* * * * *