



US008538838B2

(12) **United States Patent**  
**Doyle, III**

(10) **Patent No.:** **US 8,538,838 B2**  
(45) **Date of Patent:** **Sep. 17, 2013**

(54) **SYSTEM FOR PAIRING VEHICLE COMPONENTS**

(75) Inventor: **Marquis D. Doyle, III**, Clemmons, NC (US)

(73) Assignee: **QUALCOMM Incorporated**, San Diego, CA (US)

(\*) Notice: Subject to any disclaimer, the term of this patent is extended or adjusted under 35 U.S.C. 154(b) by 460 days.

(21) Appl. No.: **12/247,095**

(22) Filed: **Oct. 7, 2008**

(65) **Prior Publication Data**

US 2010/0085215 A1 Apr. 8, 2010

(51) **Int. Cl.**  
*A01K 5/02* (2006.01)  
*G08B 13/14* (2006.01)

(52) **U.S. Cl.**  
USPC ..... **705/29**; 340/572.1

(58) **Field of Classification Search**  
USPC ..... 705/29  
See application file for complete search history.

(56) **References Cited**

U.S. PATENT DOCUMENTS

6,442,158	B1 *	8/2002	Beser	370/352
8,284,037	B2 *	10/2012	Rennie et al.	340/426.16
2007/0285241	A1 *	12/2007	Griebenow et al.	340/572.1
2008/0221827	A1 *	9/2008	Boesch et al.	702/146
2009/0228157	A1 *	9/2009	Breed	701/1

\* cited by examiner

*Primary Examiner* — Garcia Ade

(74) *Attorney, Agent, or Firm* — Ashish L. Patel; Gerald P. Joyce, III

(57) **ABSTRACT**

The specification and drawing figures describe and show a system for pairing and decoupling vehicle components. The vehicle components may be disparate and distantly located from one another. The system includes a network management center having one or more data processing systems that may communicate with the vehicle components. An integrated wireless equipment management system is included whose components are mountable on the vehicle components, and operatively connectable to the network management center. Asset tracking units are located on each vehicle component, and are operatively connectable to the network management center. At least one executable program is included that is capable of processing data received across the integrated wireless equipment management system to establish a compatible communications connection between the asset tracking units to correctly pair the vehicle components.

**18 Claims, 7 Drawing Sheets**

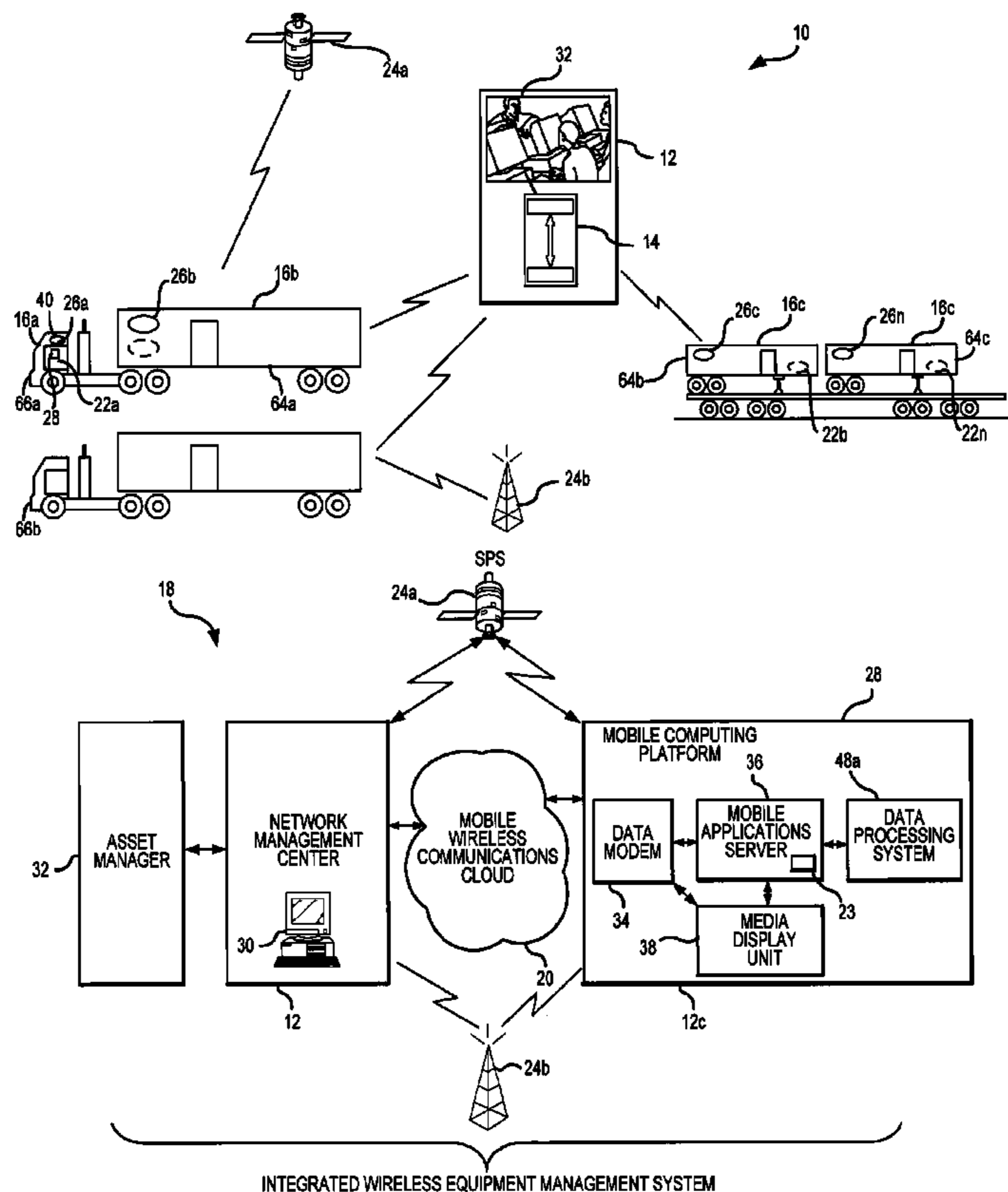

INTEGRATED WIRELESS EQUIPMENT MANAGEMENT SYSTEM

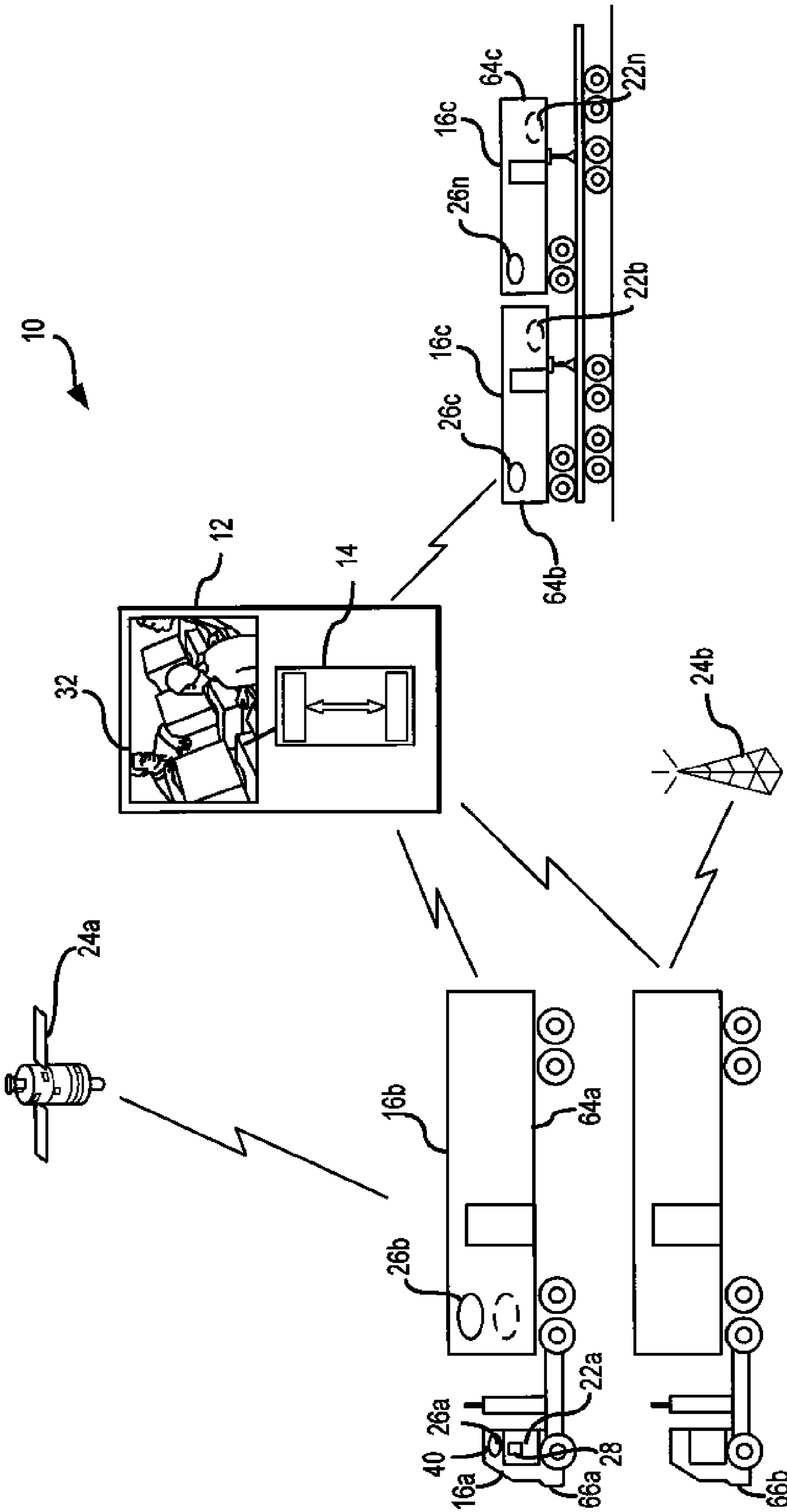

FIG. 1A

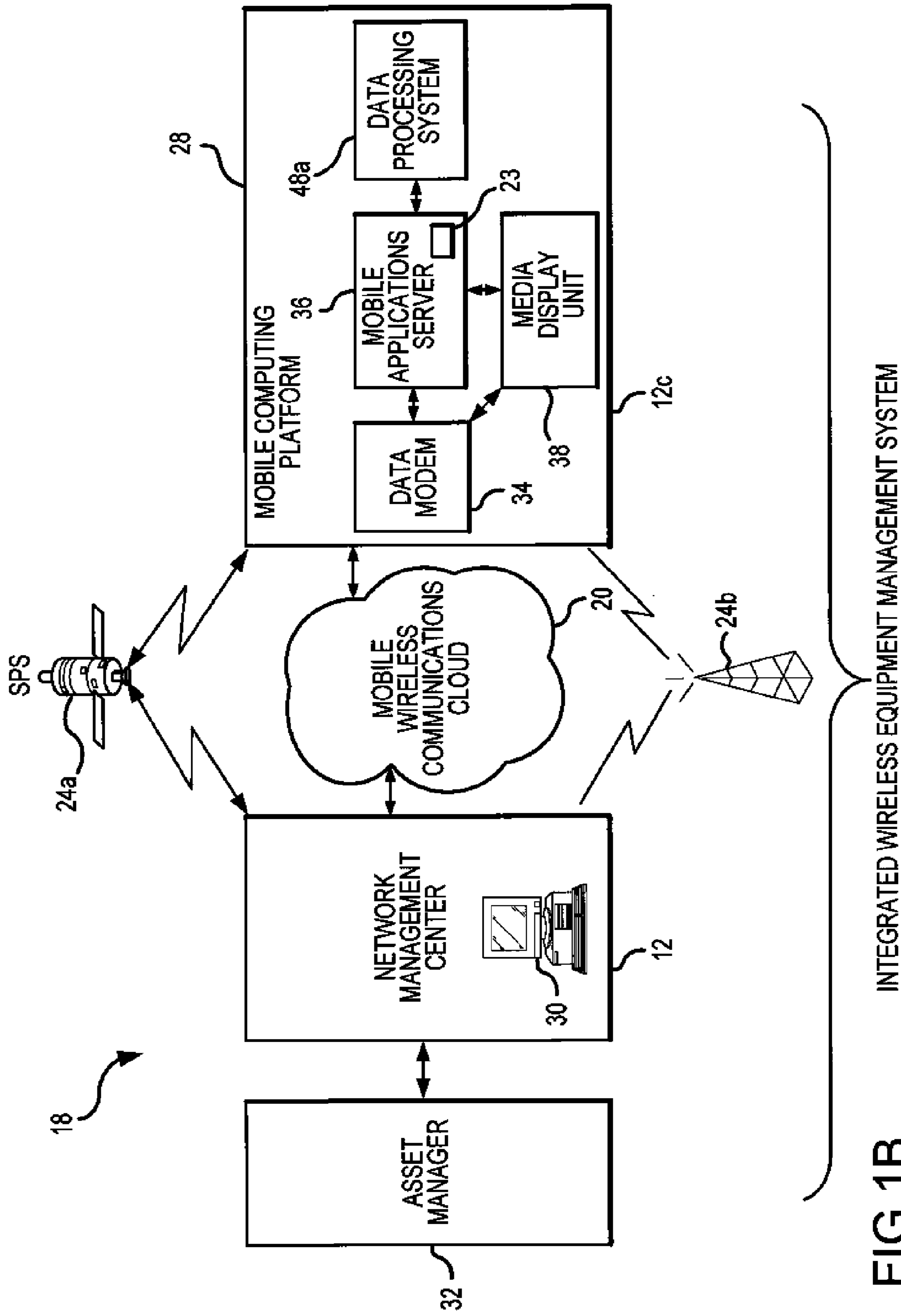

FIG. 1B

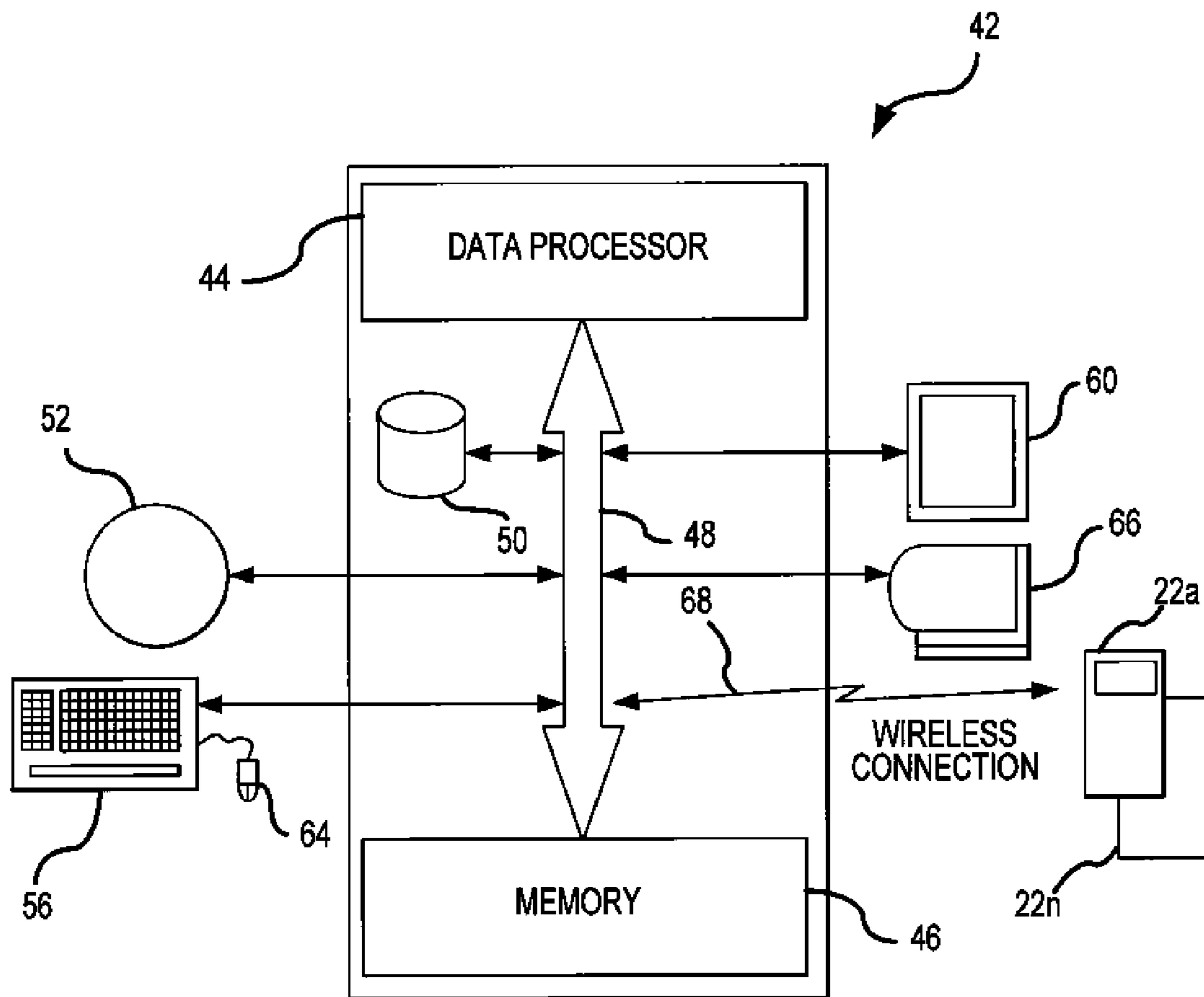

FIG. 2

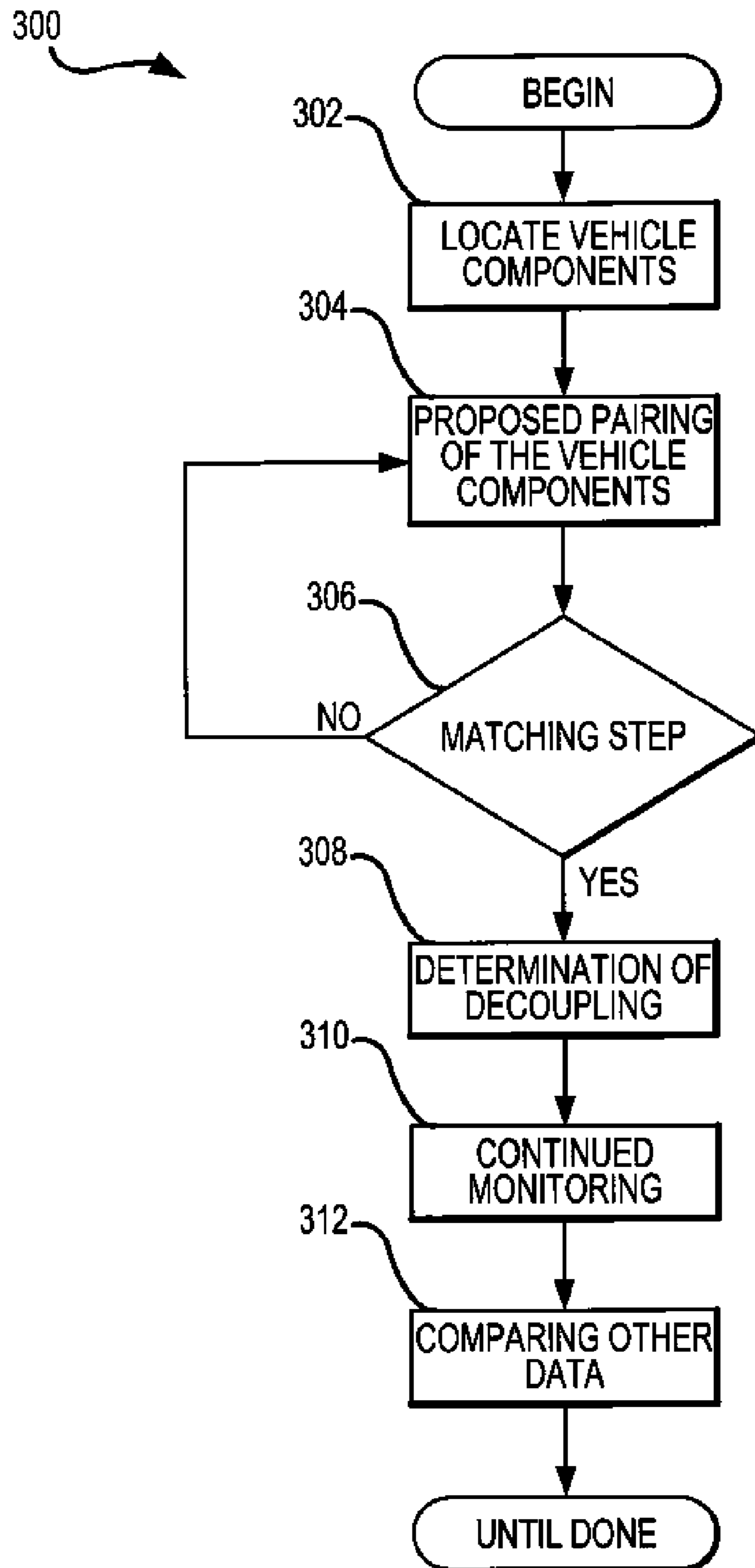

FIG.3

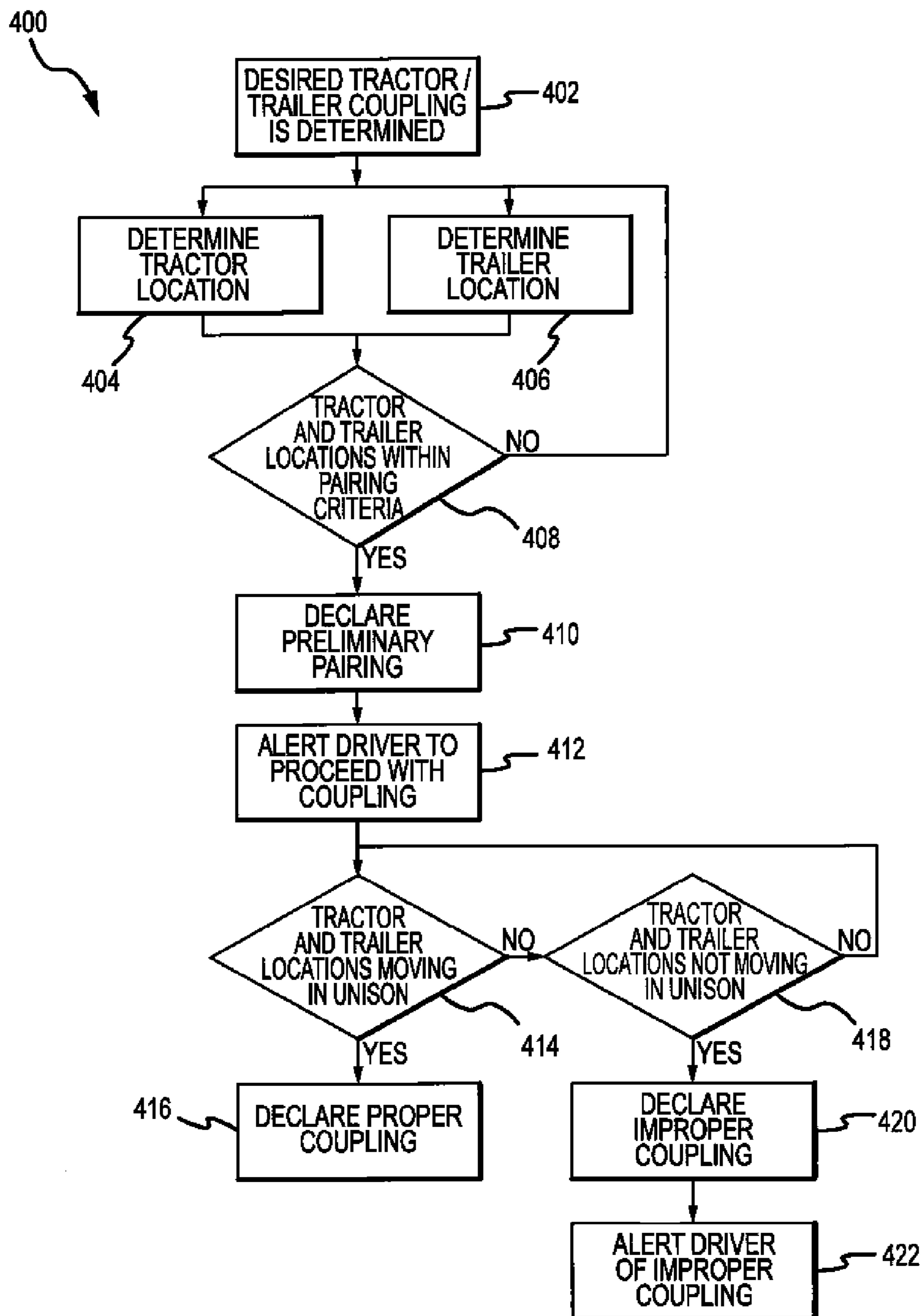

FIG.4

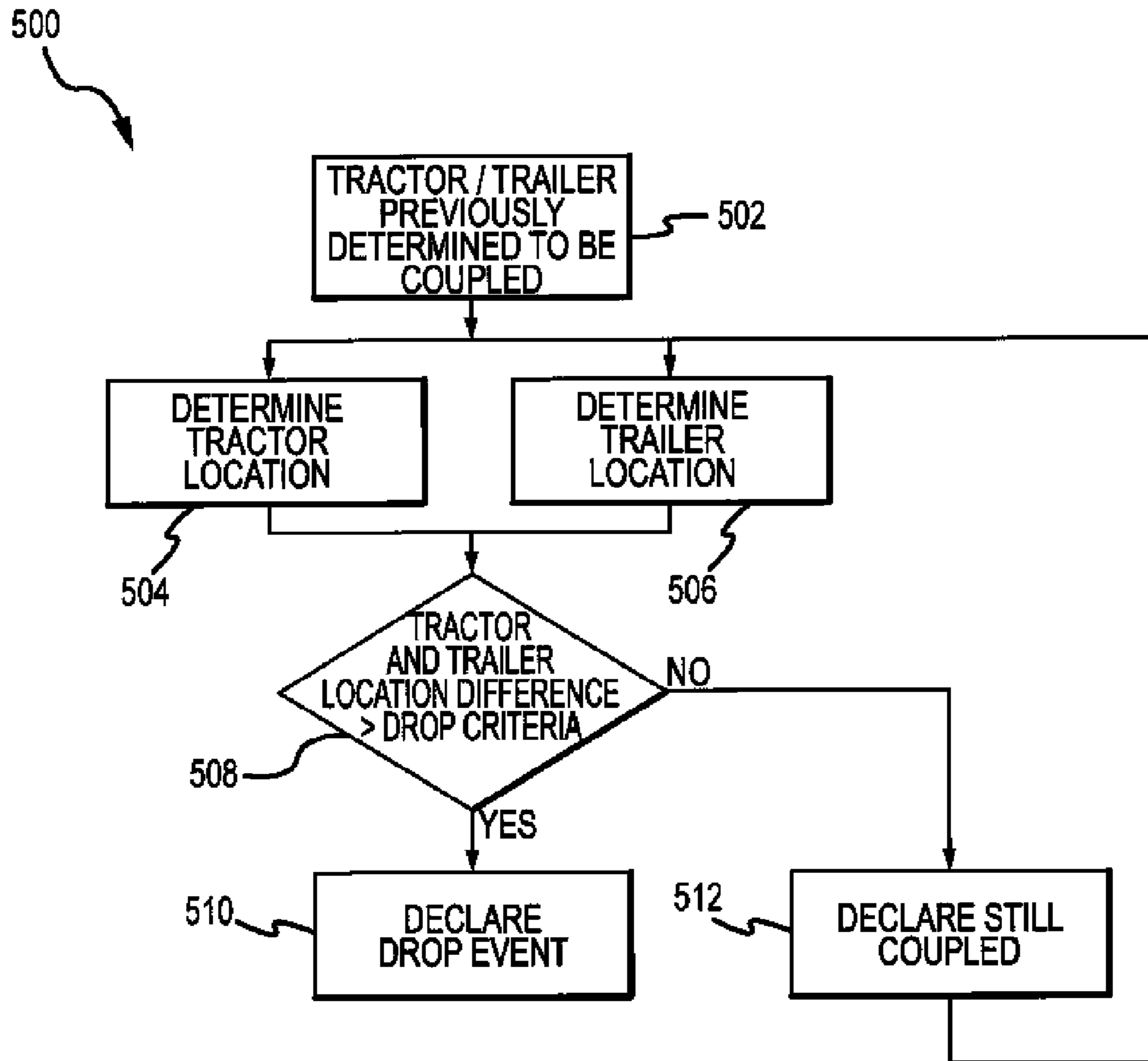

FIG.5

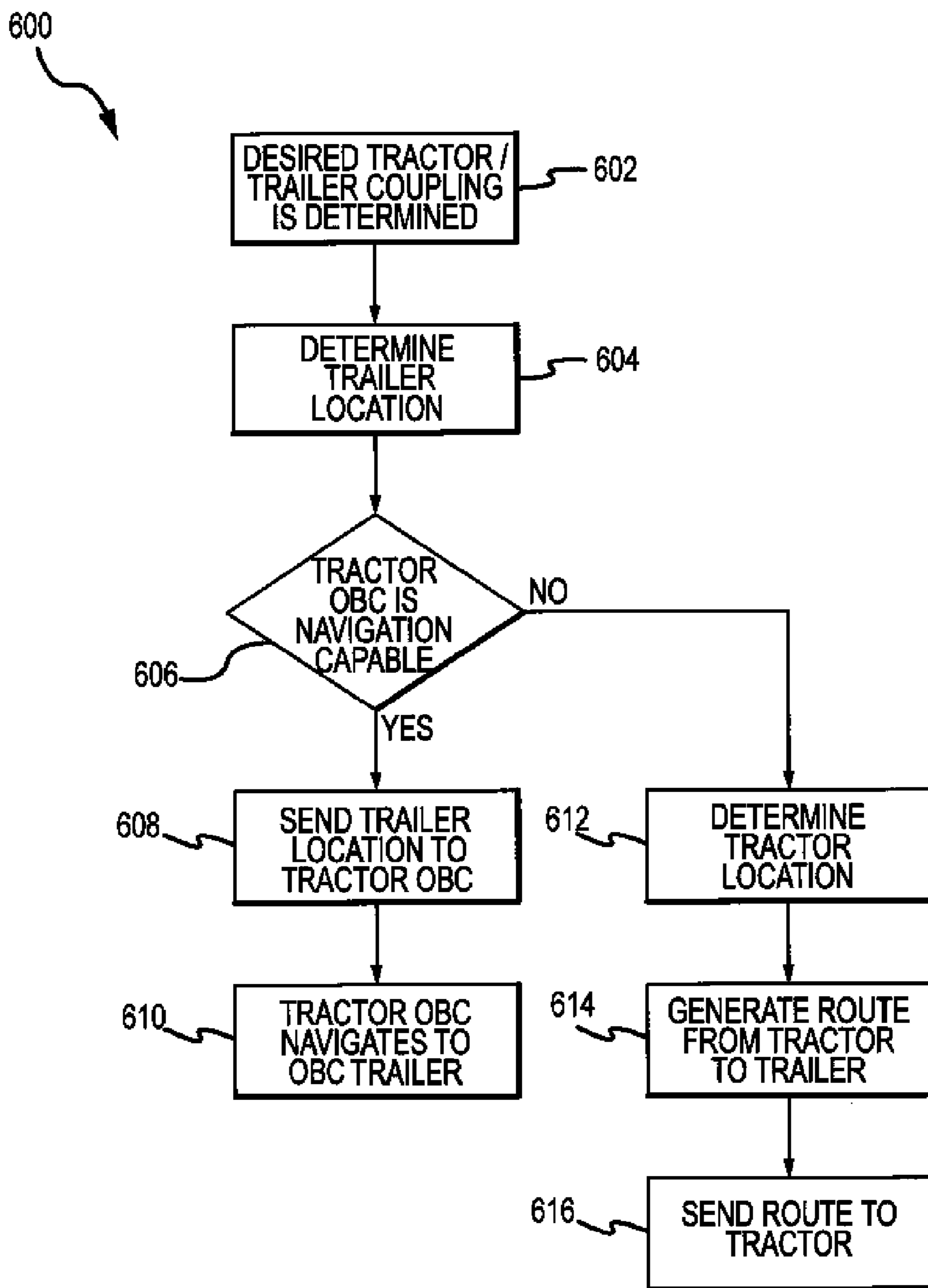

FIG.6



## 1

## SYSTEM FOR PAIRING VEHICLE COMPONENTS

## BACKGROUND

## 1. Field

The apparatus, methods, and systems disclosed, illustrated and claimed in this document pertain generally to establishing and maintaining communications links between separable movable objects. More particularly, the new and useful system for pairing vehicle components disclosed and claimed in this document is capable of identifying and authenticating movable objects such as vehicle components to be either physically coupled or physically decoupled, confirming that the correct movable objects have been coupled, and/or confirming that the correct vehicle components have been decoupled. The system for pairing vehicle components is particularly but not exclusively useful in one non-exclusive aspect for identifying, authenticating, and confirming physical coupling and physical decoupling of vehicle components such as tractors and trailers.

## 2. Background

Mobile asset management is a major concern in various transportation industries such as trucking, railroad, industrial equipment, and similar industries. In the trucking industry, for example, an asset manager may desire to track the status and location of several tractor and trailer assets that are included within the scope of the term “vehicle components” in this document.

An asset manager may want to know whether a vehicle component is in service, where the vehicle component is located, as well as a wide range of status questions in connection with one or more vehicle components (collectively, “vehicle status”). If an asset manager is able to collect reliable information about the vehicle status of vehicle components, an asset manager can confidently monitor, arrange for, and confirm accurate and correct pairing of vehicle components. Without such reliable information, confusion and error is likely in connection with efforts associated with pairing of vehicle components.

Presently, however, consistently reliable and accurate identification and authentication of pairing status of vehicle components by an asset manager is not always possible. In addition, consistently accurate confirmation about either physical coupling, or about correct decoupling, is not possible. These limitations of the current state of the art are the result of at least the following factors. about correct decoupling, is not possible. These limitations of the current state of the art are the result of at least the following factors.

Basic communication between movable objects such as tractors and trailers often is unreliable. Several methods in current use provide basic, low bandwidth data communication using one or more dedicated wires, a power line communications configuration, and/or a short range wireless link. However, those systems may be unreliable and often are proprietary. If proprietary, communication failures may occur between and among vehicle components equipped with communication apparatus from different sources. To achieve the pairing goals of an asset manager, movable objects such as a tractor and trailer must have, or be able to establish, reliable and consistently operable electrical connections between the vehicle components, or, in the case of some wireless apparatus, be in close proximity, and have compatible devices installed to be able to communicate.

Another problem is pairing uncertainty using short range wireless links such as radio frequency, acoustic, and/or infrared systems. The short operational range of such systems is a

## 2

significant limitation. Assuming that a tractor initiates a request for authentication as a prelude to physical coupling with a specific trailer, there may be in the vicinity of the tractor a number of other trailers within wireless range that are equipped with compatible asset tracking units, each suggesting it is the “correct” (but actually is incorrect) trailer to be physically coupled.

Similarly, if a tractor is in fact correctly identified for physical coupling with the proper intended trailer, those charged with accomplishing the physical coupling may err by coupling the tractor to an incorrect trailer, a result undetectable until after the tractor has moved from its location with the unintended trailer.

## SUMMARY

The solution to the range of problems encountered in seeking to correctly pair moveable objects such as tractors and trailers is disclosed, illustrated and claimed in this document as a system for pairing vehicle components, a system that results in additional unanticipated capabilities.

The systems, methods, and apparatus disclosed, illustrated and claimed in this document achieve reliable communication links between physically separated objects. As a consequence, at least one capability of the new and useful systems, methods, and apparatus is accurate identification and authentication of objects to be physically coupled and/or decoupled, and confirmation of accurate physical coupling and decoupling of the objects.

In one non-exclusive aspect, therefore, disparate vehicle components may be identified and authenticated as being the correct vehicle components intended to be physically coupled. Following physical coupling, communications links are used to confirm that the correct vehicle components have been coupled. In addition, continued physical coupling can be confirmed. Likewise, proper decoupling of the vehicle components can be confirmed.

These advances in the art are achieved by providing a virtual data communication link between one or more location determination devices, such as asset tracking units that are located on moveable objects such as tractors and trailers. The asset tracking units may be operatively connectable to one or more integrated wireless equipment management systems. Such integrated wireless equipment management systems provide the capability of being operatively connectable to one or more remote servers. The one or more remote servers may be located at a wireless base station (in this document, a “network management center”) to assist in substantially continuously and automatically receiving and transmitting location information related to tractors and trailers monitored by the wireless base station or network management center.

In addition to the primary capabilities of the system, the current uncertainty about the accuracy of physical coupling and decoupling of objects resulting from use of short range wireless links between objects such as vehicle components is overcome by establishing a short range data link if a short range data link is needed.

The virtual data communications link and the short range data link, if necessary, either separately or in combination, use one or more algorithms and methods to substantially automatically reconfigure communications data to achieve the capabilities described in this document.

As indicated, in at least one aspect of the system for pairing vehicle components, a virtual data communication link is established between one or more asset tracking units located on moveable objects such as vehicle components. The asset

tracking units are operatively connectable across an integrated wireless equipment management system. A further advancement in the art is achieved by establishing a virtual data connection between the asset tracking units across the integrated wireless equipment management system. Further, if the one or more algorithms for creating the virtual data communication link between one or more mobile wireless communication instruments determine a need for a virtual data communications link, the integrated wireless equipment management system is programmable to create the virtual data communication link on demand.

Additional benefits are achieved by the system for pairing vehicle components that include, but are not limited to:

The system provides communication between a specific tractor and a specific trailer regardless of the distance of physical separation between the tractor and the trailer.

The system provides a communications link between a specific tractor and a specific trailer although the electronics associated with the asset tracking units and installed on the vehicle components may be supplied by different vendors, and although the installed electronics and associated communications systems may be different or disparate.

Means are provided for communications between a specific tractor and a plurality of specific trailers in recognition that some tractors may haul multiple trailers and/or multiple equipment components.

The system provides a way to validate either that a tractor has coupled with the intended trailer, or has coupled with an unintended trailer.

Management tools provided by the system include the capability of detecting and validating that a tractor has decoupled from a trailer at an intended location.

The system provides a way to direct a tractor to one or more intended vehicle components for coupling or hitching.

Another management tool includes the capability to determine actual tractor and trailer pairings while providing communication links between those paired tractors and/or trailers.

The system also provides a management tool for providing authentication necessary to establish a short range wireless link between a tractor and a trailer, or between one or more equipment components and/or vehicle components.

The system for pairing vehicle components also is fully adaptable for use with existing systems already used by asset managers to monitor vehicle component status. To assist and enable an asset manager to monitor remote vehicle status and vehicle components, a system for at least two-way communications between one or more wireless base stations also referred to as network management centers, which may be operated and monitored by a vehicle dispatcher, or asset manager, and one or more vehicle components, has been developed.

To enhance (i) communications between vehicle components and the network management center, (ii) data development, (iii) data storage, and (iv) receipt and transmission of data, information and reports between vehicle components and a network management center, a variety of location determination systems are available to provide location information. The capabilities of the combination of a network management center and a location determination system may include the ability to track and collect vehicle data, the location of a remote vehicle and one or more vehicle components, and similar objectives critical to asset management. The integrated wireless equipment management system also allows an asset manager to monitor and gather information about various problems confronted by vehicle operators in connection with operation of a remote vehicle along a transportation

network, such as identifying the location of remote vehicles and one or more vehicle components and, as disclosed, illustrated, and claimed in this document, pairing vehicle components.

Exemplary integrated wireless equipment management systems that provide at least location information in connection with an asset tracking unit mounted on a tractor or trailer and a network management center using location information obtained from a location determination system include the QUALCOMM® Mobile Computing Platform and QUALCOMM Incorporated's T2 Untethered TrailerTRACS™ Asset Management System (in this document referred to as an "integrated wireless equipment management system"). Constituent components of an integrated wireless equipment management system are mountable on a vehicle or on vehicle components, as well as at the network management center, and also may be operatively connectable across a wireless communications system.

An integrated wireless equipment management system may be operatively connected to a terrestrial location determination system, or to an SPS or GPS system, or to a combination of both location determination systems. The integrated wireless equipment management system may include a range of capabilities. QUALCOMM Incorporated's T2 Untethered TrailerTRACS™ Asset Management System, for example, is capable of processing and managing message traffic at least between a customer and a trailer/container. The T2 system includes QUALCOMM Incorporated software and other sourced software used by the customer and asset manager to receive and send information over the wireless network, and may also perform a range of additional functions via the Internet. In addition, a mobile wireless communications system also provides alternative channels of communications allowing use of conventional laptop computers.

However, at least one unmet demand of asset managers is for a new and useful system for accurately locating and pairing vehicle components, however disparate, and regardless of the distance separating the vehicle components, and despite the fact that communications systems between vehicle components are dissimilar.

It will become apparent to one skilled in the art that the claimed subject matter as a whole, including the structure of the apparatus, and the cooperation of the elements of the apparatus, combine to result in a number of unexpected advantages and utilities. The structure and co-operation of structure of the system for pairing disparate vehicle components will become apparent to those skilled in the art when read in conjunction with the following description, drawing figures, and appended claims.

The foregoing has outlined broadly the more important features of the system for pairing vehicle components to better understand and appreciate the detailed description that follows, and to better understand the contributions to the art. The system for pairing vehicle components is not limited in application to the details of construction, and to the arrangements of the components, provided in the following description and drawing figures, but is capable of other embodiments, and of being practiced and carried out in various ways. The phraseology and terminology employed in this disclosure are for purpose of description, and therefore should not be regarded as limiting. As those skilled in the art will appreciate, the conception on which this disclosure is based readily may be used as a basis for designing other structures, methods, and systems for pairing movable objects. The claims, therefore, include equivalent constructions. Further, the abstract associated with this disclosure is intended neither to

5

define the system for pairing disparate vehicle components, which is measured by the claims, nor intended to limit the scope of the claims.

The novel features of the system for pairing disparate vehicle components are best understood from the accompanying drawing, considered in connection with the accompanying description of the drawing, in which similar reference characters refer to similar parts, and in which:

#### BRIEF DESCRIPTION OF THE DRAWING

FIG. 1A illustrates the system for pairing vehicle components in an operative environment;

FIG. 1B of the drawing is a block diagram of an integrated wireless equipment management system;

FIG. 2 illustrates a general data processor system whose components may be used in connection with the system for pairing vehicle components;

FIG. 3 is a flowchart illustrative of steps in an executable program included in the system for pairing vehicle components;

FIG. 4 is a flowchart illustrative of steps in another aspect of the system for pairing vehicle components;

FIG. 5 is a flowchart illustrative of steps in another aspect of the system for pairing vehicle components; and

FIG. 6 is a flowchart illustrative of steps in another aspect of the system for pairing vehicle components.

To the extent that the numerical designations in the drawing figures include lower case letters such as "a,b" such designations include multiple references, and the letter "n" in lower case such as "a-n", is intended to express a number of repetitions of the element designated by that numerical reference and subscripts.

#### DETAILED DESCRIPTION

##### Definitions

The term "integrated wireless equipment management system" means at least the QUALCOMM® Mobile Computing Platform, but also includes any similar system capable of tracking a vehicle component by mobile two-way satellite and/or terrestrial means, such as the QUALCOMM® T2 system.

The term "network management center" means at least one or more customer base stations that may be operated and monitored by a vehicle dispatcher or asset manager, and one or more vehicle components, across an integrated wireless equipment management system.

The term "asset manager" means a user of the system described, illustrated, and claimed in this document, including subscribers to an integrated wireless equipment management system, and any agent designated by the subscriber.

The term "coordinates" means any set of numbers or other data used to specify the geographic location of a point on a line, surface, or in space, such as the location of vehicle components.

The term "location determination system" means any individual or combination of methods and apparatus used with (a) terrestrial location determination systems and with (b) various satellite positioning systems ("SPS"), such as the United States Global Positioning System ("GPS"), the Russian Glonass system, the European Galileo system, any system that uses satellites from a combination of satellite systems, or any satellite system developed in the future. Furthermore, the disclosed method and apparatus of this document may be used with positioning determination systems that utilize

6

pseudolites or a combination of satellites and pseudolites. Pseudolites are ground-based transmitters that broadcast a PN code or other ranging code (similar to a OPS or CDMA cellular signal) modulated on an L-band (or other frequency) carrier signal, which may be synchronized with OPS time. Each such transmitter may be assigned a unique PN code so as to permit identification by a remote receiver. Pseudolites are useful in situations where GPS signals from an orbiting satellite might be unavailable, such as in tunnels, mines, buildings, urban canyons or other enclosed areas. Another implementation of pseudolites is known as radio-beacons. The term "satellite", as used herein, is intended to include pseudolites, equivalents of pseudolites, and others.

The term "vehicle data" and/or "remote vehicle data" means information about a vehicle including at least, but not limited to, a geographical location, including geographical coordinates among other position location indicators.

The term "vehicle" as used in this document means motorized vehicles including trucks, cars, and trains, ships, boats, and the like, and the term "vehicle components" means not only a motorized vehicle, but also associated components attachable and decouplable from a vehicle, such as containers, trailers, heavy equipment transported on trailers and flatbeds, and similar assets. Thus, the term "vehicle components" means a tractor, trailer, and similar movable assets in various transportation industries such as trucking, railroad, industrial equipment, and similar industries.

The term "remote" means an object like a vehicle that is removed in space from another systemically interrelated but distant object or objects like an asset manager using an integrated wireless equipment management system.

The term "disparate" as used in this document in connection with moveable objects such as, in one aspect, tethered or untethered vehicles, tractors, trailers and containers mountable on trailers, means not only different, but includes also markedly unrelated objects that may not be manufactured by the same manufacturer; may not be in close proximity to each other; may not share common or compatible communication and/or linking devices, apparatus, or systems; may be located in different and varying geographic locations; may use different and mutually exclusive proprietary communication and/or linking devices, apparatus, or systems; and but for the invention disclosed, illustrated and claimed in this document, could not be identified and paired or coupled with consistent accuracy. Accordingly, "disparate" may refer to different moveable objects such as a tethered or untethered vehicle, a tractor, a trailer, and/or a container mountable on a trailer that share a common manufacture source and share similar communication and/or linking devices, apparatus, or systems. However, as indicated, disparate objects also may share no common pairing or coupling feature.

The terms "pair" or "paired" and/or "pairing" mean at least to couple or join physically moveable objects, such as, for example, coupling a specific tractor with a specific trailer and/or container. The terms also mean to establish a wireless communications link between moveable objects such as one or more specific tractors and one or more specific trailers and/or containers, whether physically coupled or decoupled. The terms also mean to account for one or more movable objects, such as a moveable object like a tethered or untethered vehicle, tractor, trailer and/or container.

The term "pin location" means the location of the attachment point on a trailer that latches to or connects to a truck for coupling. The pin location is the single pivot point between the tractor and the trailer when the two vehicle components are coupled or attached.

The term “slide location” means the location of the attachment point on a tractor that is latched to or connected to the pin.

The term “on-board computer” refers generally to a computer installed on a vehicle component such as a tractor that is capable of running all mobile applications of an integrated wireless equipment management system of the kind described in this document.

As used in this document the term “exemplary” means serving as an example, instance, or illustration; any aspect described in this document as “exemplary” is not intended to mean preferred or advantageous over other aspects of the invention.

#### Description

As illustrated in the accompanying drawing FIGS. 1A-6, a system for pairing movable objects such as vehicle components is provided that in its broadest context includes one or more asset tracking units mounted on the movable objects. In the case of vehicle components, the asset tracking units are operatively connected to a network management center across an integrated wireless equipment management system. In the network management center and on the asset tracking units of the plurality of movable objects, such as tractors and trailers, a protocol such as an algorithm is stored in a data processing system that is capable of creating a virtual data connection between the one or more asset tracking units for accurately identifying and authenticating the movable objects, regardless of (i) the distance between the plurality of movable objects, (ii) how disparate the movable objects are, and (iii) how different the asset tracking units are. The system also is capable of overcoming pairing uncertainty resulting from short-range wireless communications links by establishing a short-range data link between the vehicle components if needed. Accordingly, the virtual data communications link and the short range data link may operate separately or in combination to reconfigure communications data to identify and authenticate vehicle components to be physically coupled and decoupled, and to confirm correct coupling and decoupling.

More specifically, as illustrated by cross-reference between FIGS. 1A-1B, a system for pairing vehicle components 10 includes a network management center 12 having one or more data processing systems 14 operatively connectable to vehicle components 16a-n. The system includes an integrated wireless equipment management system 18 with components mountable in part on the vehicle components 16a-n and operatively connectable to the network management center 12 across a mobile wireless communications cloud 20. In addition, an asset tracking unit 22a-n is locatable on each vehicle component 16a-n. An executable program is provided that is capable of processing data to establish a compatible communications connection between the asset tracking units 22a-n located on the vehicle components 16a-n. The executable program is illustrated diagrammatically in FIG. 1B as reference character 23 for illustration purposes only. The executable program 23 is designed and adapted to correctly pair the vehicle components 16a-n. In addition, as also illustrated in FIGS. 1A-1B, the location determination system 24a,b includes a receiver 26 operatively connected to a mobile computing platform 28 located on at least one of the vehicle components 16a-n, and also is operatively connectable across the wireless communications cloud 20.

The integrated wireless equipment management system 18 may consist of the QUALCOMM® Mobile Computing Platform, but may also include QUALCOMM Incorporated’s

OMNITRACS® Mobile Communications System, and QUALCOMM Incorporated’s T2 System for terrestrial wireless communications, among others. As indicated the SPS and GPS and terrestrial location determination systems 24a,b may operate alone or in combination to achieve the objectives of the system for pairing vehicle components 10.

As also illustrated by cross-reference between FIGS. 1A and 1B, a system for pairing vehicle components 10 also includes a mobile computing platform 28. The mobile computing platform 28 is mounted on the remote vehicle component 16a, for example, and is shown diagrammatically in FIG. 1A for illustrative purposes only. As further illustrated by cross-reference between FIGS. 1A and 1B, the mobile computing platform 28 mounted on vehicle component 16a is operatively connectable across the wireless communications cloud 20. As also illustrated by cross-reference between FIGS. 1A-1B, the mobile computing platform 28 and computer elements 30a-n of the asset manager’s 32 network management center 12 are capable of storing in memory at least varying coordinates that identify changing locations of a vehicle component 16a-n.

As further illustrated by cross-reference between FIGS. 1A and 1B, the mobile computing platform 28 may include a data modem 34, a mobile applications server 36, and a media display unit 38 mounted in the remote vehicle component 16a for viewing by an operator of the remote vehicle component 16a. Either alone or in combination, the data modem 34, mobile applications server 36, and/or the media display unit 38 may act as, or support, the asset tracking units 22. The data modem 34 includes an antenna 40 capable of receiving and transmitting messages and signals to the mobile application server 36 across the wireless communications cloud 20 illustrated diagrammatically in FIG. 1B. Antenna 40 may be housed adjacent to the position determination receiver 26 as illustrated in FIG. 1A. As a person skilled in the art will appreciate, however, the location of the position determination receiver 26, as well as the other electronic components disclosed in this document, is not a limitation of the system for pairing vehicle components 10.

The mobile application server 36 is capable of receipt and transmission of at least data and information relating to location of the vehicle components 16a-n. The mobile application server 36 is not limited to capabilities described in this document, and may include a plurality of programmable general-purpose computers and/or data processing systems 42, described in greater detail in FIG. 2, capable of receiving, storing, processing and transmitting a wide range of data and information to an asset manager 52 about remote and vehicle components 16a-n. Although not shown, the mobile computing platform 28 may also include an optional compact display unit, a remote control unit and at least one speaker to enhance receipt and transmission of data and information across the wireless communication system 20. The media display unit 44, and any additional units such as an optional compact display unit (not shown), enable a vehicle operator and/or a vehicle passenger to communicate with at least one asset manager 38 as illustrated in FIG. 1A.

Both in the mobile computing platform 28, and in the network management center 12 where the asset manager 32 monitors data and information received, stored, and processed in connection with the location of vehicle components 16a-n provided by the location determination systems 24a,b, a number of computer assisted elements 30 may be included. As illustrated by cross-reference between FIGS. 1B and 2, wireless communications system 20 and/or mobile computing platform 28 and/or computer elements 30 include a data processing system 42. As illustrated, the data processing sys-

tem **42** may include a variety of components to enable the integrated wireless equipment management system **18** to send and receive location data and information to and from the asset manager's network management center **12** to enable an asset manager **32** to monitor at least one vehicle component **16a-n**. A person skilled in the art will appreciate that all information and data generated, received, stored, processed and transmitted between the on-board computing platform **28** of the integrated wireless equipment management system **18** may be received, stored, processed, and transmitted to a computer or similar apparatus.

As illustrated in FIG. 2, the data processing system **42** includes a data processor **44** and a memory **46**. A bus **48** connects the data processor **44** and memory **46**. Memory **46** is a relatively high-speed machine-readable medium and may include volatile memories such as DRAM, and SRAM, or maybe non-volatile memories such as ROM, FLASH, EPROM, EEPROM, and bubble memory. Also connectable to or across computer bus **48** are optional secondary storage **50**, external storage **52**, and output devices such as a monitor **54**. In further optional configurations, an input device such as a keyboard **56** with a mouse **58**, and perhaps a printer **60** may be included. Secondary storage **50** may include machine-readable media such as a hard disk drive, a magnetic drum, and bubble memory (not shown). External storage **52** may include machine-readable media such as a floppy disk, a removable hard drive, a magnetic tape, CS-ROM and even other data processors (not shown) connected across a wireless communications link **62** to one or more assets tracking units **22a-n**.

The distinction between secondary storage **50** and external storage **52** is primarily for convenience in describing the various components of the data processor **44**. As such, a person skilled in the art will appreciate that there is substantial functional overlap between and among the components. Data processor software and user programs may be stored in a software storage medium such as memory **46**, secondary storage **50**, and external storage **52**. Executable versions of data processor software can be read from a storage medium such as non-volatile memory, loaded for execution directly into volatile memory, executed directly out of non-volatile memory, or stored in the secondary storage **50** prior to loading into volatile memory for execution.

Accordingly, in combination the integrated wireless equipment management system **18**, the asset tracking units **22**, and the data processing system **42** (the latter being located in computer elements **30** of the network management center **12** and on the vehicle components **16a-n**) function, in operation, to receive, collect, share, process and transmit at least location data and information related to the location of the vehicle components **16a-n**.

Those of skill in the art also will appreciate that the various illustrative logical blocks, modules, circuits, and algorithm steps described in connection with the aspects disclosed in this document may be implemented as electronic hardware, computer software, or combinations of both. To clearly illustrate this interchangeability of hardware and software, various illustrative components, blocks, modules, circuits, and steps have been described in this document generally in terms of their functionality. Whether such functionality is implemented as hardware or software depends on the particular application and design constraints imposed on an overall system. Skilled artisans may implement the described functionality in varying ways for each particular application, but such implementation decisions should not be interpreted as causing a departure from the scope of the present invention.

The various illustrative logical blocks, modules, and circuits described in connection with the aspects disclosed in this document may be implemented or performed with a general purpose processor, a Digital Signal Processor (DSP), an Application Specific Integrated Circuit (ASIC), a Field Programmable Gate Array (FPGA) or other programmable logic device, discrete gate or transistor logic, discrete hardware components, or any combination thereof designed to perform the functions described herein. A general-purpose processor may be a microprocessor, but in the alternative, the processor may be any conventional processor, controller, microcontroller, or state machine. A processor may also be implemented as a combination of computing devices such as, in a non-exclusive example, a combination of a DSP and a microprocessor, a plurality of microprocessors, one or more microprocessors in conjunction with a DSP core, or any other such configuration.

One or more algorithms associated with the mobile computing platform **28** illustrated in this document may be embodied directly in hardware, in a software module executed by a processor, or in a combination of the two. A software module may reside in Random Access Memory (RAM), flash memory, Read Only Memory (ROM), Electrically Programmable ROM (EPROM), Electrically Erasable Programmable ROM (EEPROM), registers, hard disk, a removable disk, a CD-ROM, or any other form of storage medium known in the art. An exemplary storage medium is coupled to the processor so the processor may read information from, and writes information to, the storage medium. In the alternative, the storage medium may be integral to the processor. The processor and the storage medium may reside in an ASIC. An ASIC, if used, may reside in the mobile computing platform. In the alternative, the processor and the storage medium may reside as discrete components in any component of the mobile computing platform.

Any machine-readable medium tangibly embodying instructions may be used in implementing the methodologies described in this document. As a non-exclusive example, protocols, executable programs **23**, and related software codes may be stored in a memory **46** or database as illustrated in FIG. 2, and executed by a data processor **44**, for example a microprocessor of the mobile applications server **36**. Memory may be implemented within the data processor **44** or external memory **52**. As used in this document, the term "memory" refers to any type of long term, short term, volatile, nonvolatile, or other memory and is not to be limited to any particular type of memory or number of memories, or type of media upon which memory is stored.

In operation, it will now be evident that the system for pairing vehicle components **10** is applicable in the broader sense for locating and pairing a plurality of movable objects including, without limitation, vehicle components **16a-n**. As illustrated, a method of locating and pairing a plurality of movable objects such as vehicle components **16a-n** includes the step of equipping the plurality of movable objects **16a-n** with one or more asset tracking units **22a-n**.

In addition, at least one protocol, generally in the form of an executable program **23**, capable of processing location data received across the integrated wireless equipment management system **18** and stored either in the network management center **12** and in one or more asset tracking units **22a-n** on the plurality of movable objects **16a-n**, provides for accurately locating and pairing the movable objects **16a-n** regardless of the physical distance between the plurality of movable objects **16a-n**, and regardless how disparate the movable objects **16a-n** may be. Thus, the protocol is capable of estab-

## 11

lishing a compatible communications connection and link between the asset tracking units **22a-n** located on the plurality of movable objects **16a-n**.

The actual communications connection for receipt and transmission of data may be any structure or architecture necessary for operation of the asset tracking units **22a-n**. The decision will be based largely on expected data flow and coverage requirements. For example, a trailer **64a-n** as illustrated in FIG. 1A may only need connectivity while in a storage yard, a circumstance in which WiFi would suffice. However, other applications may require wider area coverage. Still other applications may require the ubiquitous coverage of a satellite system **24a**. When a wireless connection is established between the one or more asset tracking units **22a-n** located on the vehicle **16a** and vehicle components **16b-n**, the network management center **12**, as illustrated in FIG. 1A, is capable of communicating with, monitoring, and managing location data received from and/or directed to a tractor **72** and/or trailer **70**.

As indicated, the system for pairing vehicle components **10** includes a protocol, generally in the form of one or more executable programs **23**, capable of processing location data received across the integrated wireless equipment management system **18** to establish a compatible communications link between the asset tracking units **22a-n** located on the vehicle components **16a-n**. The executable program **23** is adapted to correctly pair the vehicle components **16a-n**, regardless of how disparate the equipment, and regardless of how distant the vehicle **16a** and vehicle components **16b-n** may be before the program **23** is applied to a specific task.

Thus, as illustrated in FIG. 3, a flowchart of a representative example of an executable program **23** is presented for illustrative purposes to show establishment of a virtual data communications link. The steps of the flowchart are illustrated in general as a method **300**. In operation, the step-by-step method **300** is capable of creating a virtual data communications link using one or more data processing systems **42** of the kind illustrated in FIG. 2. In addition, the steps of method **300** are capable of using a short range wireless link, if necessary, to establish communication between vehicle components **16a-n** for purposes of at least identifying, authenticating, and confirming the correct vehicle components **16a-n** to be physically coupled and/or physically decoupled. The steps of method **300** are as follows, and will be understood best by reference to FIG. 3.

As illustrated in FIG. 3, at step **302** the system locates vehicle components **16a-n**, regardless of how disparate the vehicle components **16a-n** may be, and regardless of the distance between or among vehicle components **16a-n**. The network management center **12**, computer elements **30**, one or more data processing systems **14** or **42**, and the integrated wireless equipment management system **18**, either alone or in combination, identify the coordinates of the location of vehicle components **16a-n** using the location determination system **24** appropriate for the application. For example, the pin location (not shown) of an intended trailer **64a-c** and the slide location (not shown) of the intended tractor **66** may be determined at authentication step **304**. The pin location of the trailer **64a-c** may be determined, for example, by the current antenna location of the antenna **40** associated with the integrated wireless equipment management system **18**. The pin location also is determined by data concerning the last direction of movement of the trailer **64a-c**, as well as by the pin offset distance from the antenna **40**. Likewise, the slide location of the tractor **66** may be determined by the current antenna location, the last direction of movement, as well as by the slide offset from the antenna **40**.

## 12

At step **304**, a pairing of vehicle components **16a-n** is proposed. For example, the network management center **12** determines an intended tractor **66** and trailer **16c** pairing. With the location information of tractor **66** and trailer **16c** from step **302**, an operator of vehicle **16a** may be notified using the integrated wireless equipment management system **18**.

A preliminary pairing is authenticated at step **306**, and the operator of the vehicle **16a** may be notified by the network management center **12** to proceed with the coupling of the vehicle components **16a-n** consisting of, in a non-exclusive example, tractor **66** and trailer **64c**. If, for example, the reported pin location and slide location begin movement in unison, the pairing, in this instance the physical coupling, is conclusively validated. Alternatively, as illustrated by steps **304** and **306**, unintended pairings may be similarly detected, and notices sent to the operator of a vehicle **16a** that tractor **66** and trailer **64c** are improperly coupled. For example, if a tractor **66** commences movement, but the trailer **64c** location remains stationary, a notice may be sent to the operator of the vehicle **16a** from the network management center **12** that an unintended coupling may have occurred.

In another aspect, the coordinates of the location of trailer **64a-n**, for example, may be retrieved from the database on an on-board computer of the tractor's **66** navigation system **28**. The on-board computer of the tractor's **66** navigation system **28** may be part of the integrated wireless equipment management system **18** located on vehicle components **16a-n**, and capable of establishing a virtual data communications link between the one or more mobile asset tracking units **22a-n**. The on-board computer is enabled to communicate directly over the virtual data communications link with trailer **64** to request the trailer's location.

The system for pairing vehicle components **10** also determines when and where to physically decouple vehicle components **16a-n** such as tractor **66** and trailer **64a-n**. The network management center **12** monitors reported locations of the paired tractor **66a** and trailer **64a-n**. As illustrated at step **308** of FIG. 3, if reported locations deviate by a predetermined distance, it can be determined that a physical decoupling event between tractor **66** and a trailer **64a-n** has occurred, and the coordinates at which the decoupling occurred may be logged across the system using the data communications capabilities of the integrated wireless equipment management system **18**. In addition, the fact of the decoupling may be automatically recorded.

At step **306** the network management center **12** also may determine desired pairing of vehicle components **16a-n** linked for communication purposes across a proprietary short range wireless link, if needed under the circumstances. Consequently, the network management center **12** provides the required authentication and pairing confirmation for short range wireless links to both the tractor **66** and a trailer **64a-n**. Alternatively, the virtual data communications link established between the tractor **66** and trailer **64a-n** allows required authentication indirectly over the virtual data communications link between the tractor and trailer. Once a short range wireless link is established, the virtual data communications link may be terminated.

Likewise, as shown in step **310**, when and where to decouple vehicle components may also include the steps of monitoring vehicle data to include the location of a paired first vehicle component **16a** and a second vehicle component **16n**, and determining from the location of the paired first vehicle component **16a** and the second vehicle component **16n** when and where to decouple the first vehicle component **16a** and the second vehicle component **16n**.

Because the network management center 12 is capable of monitoring the location of all tractors 66 and trailers 64a-n equipped with an integrated wireless equipment management system 18, actual tractor 66 and trailer 64a-n pairings may automatically be determined by comparing reported location, speed, and direction information associated with paired vehicle components 16a-n. Thus, as illustrated at step 312 of FIG. 3, tractor 66 and trailer 64a moving in unison for a predetermined amount of time would be determined as paired. However, as indicated, the virtual data communications link can automatically establish tractor and trailer pairing without the system having prior confirmation of the pairing.

Another aspect of the system for pairing vehicle components 10 is summarized and illustrated in FIG. 4 by a flowchart 400. Flowchart 400 also illustrates establishment of a virtual data communications link as contemplated and disclosed in this document. Accordingly, in operation, the step-by-step method 400 is capable of creating a virtual data communications link using one or more data processing systems 14 or 42a-n of the kind illustrated in FIG. 2. In addition, the steps of method 400 are capable of using a short range wireless link, if necessary, to establish communications between vehicle components 16a-n at least for purposes of identifying, authenticating, and confirming the correct vehicle components that are to be paired. The steps of method 400 are as follows, and will be understood best by reference to FIG. 4.

As illustrated in FIG. 4, at step 402 a desired tractor and trailer coupling is determined. As indicated in this document, the desired coupling may be determined in the network management center 12. Using any of the location determination systems 24a,b described in this document at step 404 the location of the desired tractor 66 is determined and at step 406 the location of a trailer 64a-n is likewise determined. As indicated by the decision symbol of step 408, alternatively the desired coupling of tractor 66 and trailer 64a-n may be determined in connection with alternative pairing criteria. In any event, on an identification of the proper tractor 66 and trailer 66a-n to be paired, at step 408 the correct co-location of tractor 66 and trailer 64a-n is confirmed. As a result, at step 410 a preliminary pairing authentication is declared. Thereafter, using the network management center 12, computer elements 30, one or more data processing systems 42, and the integrated wireless communication system 18, either alone or in combination, an operator of tractor 66 is alerted to proceed with the actual physical coupling. Following confirmation of physical coupling, at step 414 the network management center 12 confirms that tractor 66 and trailer 64a-n are moving in unison. Accordingly, the system for pairing vehicle components 10 therefore has identified, authenticated and confirmed physical coupling at step 416. Alternatively, however, if at step 414 it is determined that tractor 66 and trailer 64a-n are not moving in unison, as indicated at step 418, the system for pairing vehicle components 10 declares that there has been an improper coupling at step 420. Consequently, the network management center 12 alerts the operator of tractor 66 at step 422 of the improper coupling so that corrective action may be taken.

Yet another aspect of the system for pairing vehicle components 10 is illustrated in FIG. 5 using flowchart 500. As illustrated in FIG. 5, at step 502 tractor 66 and a trailer 64a-n previously have been determined to be coupled physically. The previous physical coupling is determined by data provided by the network management center 12, computer elements 30, one or more data processing systems 42, and the integrated wireless equipment management system 18, by identifying the coordinates of the tractor 66 and the trailer

64a-n using the location determination system 24 that is appropriate under the circumstances, as shown at steps 504 and 506. However, if there is a locational difference between tractor 66 and trailer 64a-n, then at step 508 the presumption of continued physical coupling between tractor 66 and trailer 64a-n is discontinued, and the network management center 12 may declare and determine a drop event, or physical decoupling of tractor 66 and trailer 64a-n as shown at step 510. Alternatively, if as a result of the data collected and processed at step 508 the tractor 66 and trailer 64a-n are shown to have no difference in locational coordinates, then the network management center 12 may declare and determine that the vehicle components continue to be physically coupled.

Another aspect of the system for pairing vehicle components 10 is illustrated in FIG. 6. An additional method of the system for pairing vehicle components 10 is shown as a flowchart 600. At step 602, once again a desired coupling of a tractor 66 and a trailer 64a-n is determined. Also, at step 604 the location of a trailer 64a-n is determined by any one of the apparatus, methods and systems described in this document. In this aspect of the system for pairing vehicle components 10, at step 606 the on-board computer, such as a mobile applications server 36, determines whether tractor 66 is capable of navigation. If so, then at step 608 the location of trailer 64a-n is sent to the on-board computer of tractor 66, and as a consequence, at step 610, tractor 66 navigates to trailer 64a-n. If, however, at step 606 it is determined that tractor 66 is not navigation capable, then at step 612 the system for pairing vehicle components 10 determines an alternative tractor 66b that may be available. Alternatively, the actual position and location of the on-board computer of the tractor 66b may be determined at this juncture in the steps to enable pairing of the tractor 66b and a trailer 64a-n. In addition, the system for pairing vehicle components 10 generates information and data between tractor 66b and trailer 64a-n. That information and data, including route instructions, are sent to tractor 66b as indicated at step 616.

The description of the disclosed aspects is provided to enable a person skilled in the art to make or use the apparatus, system, and method disclosed, illustrated and claimed in this document. Various modifications to these aspects will be readily apparent to those skilled in the art, and the generic principles defined in this document may be applied to other aspects without departing from the spirit or scope of the system for pairing disparate vehicle components system. Thus, the invention is not intended to be limited to the aspects shown in this document, but is intended to be accorded the widest scope consistent with the principles and novel features disclosed in this document.

Claim elements and steps in this document have been numbered solely as an aid in understanding the description. The numbering is not intended to, and should not be considered as intending to, indicate the ordering of elements and steps in the claims. In addition, FIGS. 1A-6 show at least one aspect of the system for pairing disparate vehicle components are not intended to be exclusive, but merely illustrative of the disclosed aspects. As a person skilled in the art will appreciate, method steps may be interchanged sequentially without departing from the scope of the invention.

What is claimed is:

1. A method of locating and pairing a plurality of movable objects, comprising:
  - receiving, at a network management center from a first asset tracking unit, a location of a first movable object;

## 15

- receiving, at the network management center from a second asset tracking unit, a location of a second movable object;
- transmitting, by a processor via a wireless communications system to the first movable object, a proposed pairing between the first movable object and the second movable object;
- receiving an indication of a pairing between the first movable object and the second movable object; and
- confirming the proposed pairing by determining, based on the location of the first movable object and the location of the second movable object, that the first movable object is moving in unison with the second movable object.
2. The method of locating and pairing a plurality of movable objects as recited in claim 1, further comprising equipping the first movable object with the first asset tracking unit and equipping the second movable object with the second asset tracking unit.
3. The method of locating and pairing a plurality of movable objects as recited in claim 1, wherein a location determination system is operatively connectable to the first and second asset tracking units, wherein the location determination system is configured to transmit data between the first and second asset tracking units and the network management center.
4. The method of locating and pairing a plurality of movable objects as recited in claim 3, wherein the location determination system is a satellite positioning system (SPS).
5. The method of locating and pairing a plurality of movable objects as recited in claim 1, further comprising establishing a virtual data connection between the first and second asset tracking units.
6. The method of locating and pairing a plurality of movable objects as recited in claim 5, wherein establishing the virtual data connection between the first and second asset tracking units comprises providing a plurality of executable programs adapted to receive, store, process and transmit data between the first and second asset tracking units and the network management center via the wireless communication system.
7. A data processing system for pairing vehicle components, comprising:
- an interface configured to receive data; and
  - a processor configured to execute a data processing module, communicating with the interface, the data processing module configured to:
    - receive, from a first asset tracking unit, a location of a first vehicle component;
    - receive, from a second asset tracking unit, a location of a second vehicle component;
    - transmit, via a wireless communications system to the first vehicle component, a proposed pairing between the first vehicle component and the second vehicle component;
    - receive an indication of a pairing between the first vehicle component and the second vehicle component; and
    - confirm the proposed pairing by determining, based on the location of the first vehicle component and the location of the second vehicle component, that the first vehicle component is moving in unison with the second vehicle component.
8. The data processing system for pairing vehicle components as recited in claim 7, wherein a mobile computing platform is mounted on the first and second vehicle components.

## 16

9. The data processing system for pairing vehicle components as recited in claim 7, wherein the data processing module is configured in a network management center.
10. The data processing system for pairing vehicle components as recited in claim 7, wherein the first and second asset tracking units are configured in a satellite positioning system (SPS).
11. The data processing system for pairing vehicle components as recited in claim 7, wherein the first and second asset tracking units are configured in a terrestrial location determination system.
12. The data processing system for pairing vehicle components as recited in claim 7, wherein the data processing module is further configured to process communication data between the first and second asset tracking units.
13. The data processing system for pairing vehicle components as recited in claim 7, wherein the data processing module comprises a programmable and executable set of instructions for receiving the locations of the first and second vehicle components, and receiving the indication of the pairing.
14. The data processing system for pairing vehicle components as recited in claim 7, wherein the data processing module is further configured to decouple the vehicle components.
15. A storage medium containing computer software encoded in machine-readable format for determining accurate vehicle component pairing, the computer software comprising:
- a set of computer instructions for receiving, from a first asset tracking unit, a location of a first vehicle component;
  - a set of computer instructions for receiving, from a second asset tracking unit, a location of a second vehicle component;
  - a set of computer instructions for transmitting a proposed pairing between the first vehicle component and the second vehicle component to the first vehicle component;
  - a set of computer instructions for receiving an indication of a pairing between the first vehicle component and the second vehicle component; and
  - a set of computer instructions for confirming the proposed pairing by determining, based on the location of the first vehicle component and the location of the second vehicle component, that the first vehicle component is moving in unison with the second vehicle component.
16. The storage medium containing computer software encoded in machine-readable format for determining accurate vehicle component pairing as recited in claim 15, wherein the locations of the first and second vehicle components are received at a network management center having one or more data processing systems operatively connectable to the first and second vehicle components.
17. The storage medium containing computer software encoded in machine-readable format for determining accurate vehicle component pairing as recited in claim 15, wherein the locations of the first and second vehicle components are received via an integrated wireless equipment management system mountable on the first and second vehicle components.
18. A system for locating and pairing a plurality of movable objects, comprising:
- means for receiving a location of a first movable object;
  - means for receiving a location of a second movable object;
  - means for transmitting a proposed pairing between the first movable object and the second movable object to the first movable object;



means for receiving an indication of a pairing between the first movable object and the second movable object; and means for confirming the proposed pairing by determining, based on the location of the first movable object and the location of the second movable object, that the first movable object is moving in unison with the second movable object.

\* \* \* \* \*