



US008529763B2

(12) **United States Patent**
Shafer et al.

(10) **Patent No.:** **US 8,529,763 B2**
(45) **Date of Patent:** **Sep. 10, 2013**

(54) **WASTE WATER TREATMENT METHOD**

(75) Inventors: **Lee L. Shafer**, Big Piney, WY (US);
John W. James, Boulder, WY (US);
Richard D. Rath, Larkspur, CO (US);
Jesse Eubank, LaBarge, WY (US)

4,889,638 A 12/1989 Rockford et al.
4,983,297 A 1/1991 Kaczmarek et al.
5,006,249 A 4/1991 Green et al.
5,120,935 A * 6/1992 Nenniger 392/305
5,342,769 A * 8/1994 Hunter et al. 435/166

(Continued)

(73) Assignee: **Anticline Disposal, LLC**, Boulder, WY (US)

FOREIGN PATENT DOCUMENTS

WO WO 2006/110574 10/2006

(*) Notice: Subject to any disclaimer, the term of this patent is extended or adjusted under 35 U.S.C. 154(b) by 9 days.

OTHER PUBLICATIONS

Corder, R. E., et al., "Biological Production of Methanol from Methane," downloaded from http://web.anl.gov/PCS/acsfuel/preprint%20archive/Files/33_3_LOS%20ANGELES_09-88_0469.pdf on Jun. 17, 2012.*

(21) Appl. No.: **13/361,005**

(22) Filed: **Jan. 30, 2012**

(Continued)

(65) **Prior Publication Data**

US 2012/0152830 A1 Jun. 21, 2012

Primary Examiner — Chester Barry

Related U.S. Application Data

(63) Continuation of application No. 12/399,242, filed on Mar. 6, 2009, now Pat. No. 8,105,488, which is a continuation-in-part of application No. 11/685,663, filed on Mar. 13, 2007, now Pat. No. 7,510,656.

(60) Provisional application No. 60/767,574, filed on Sep. 1, 2006.

(51) **Int. Cl.**
C02F 3/00 (2006.01)

(52) **U.S. Cl.**
USPC **210/605; 210/663; 210/538; 210/902**

(58) **Field of Classification Search**
USPC 210/605, 663, 538, 902
See application file for complete search history.

(57) **ABSTRACT**

Systems and methods have been developed for reclaiming water contaminated with the expected range of contaminants typically associated with produced water, including water contaminated with slick water, methanol and boron. The system includes anaerobically digesting the contaminated water, followed by aerating the water to enhance biological digestion. After aeration, the water is separated using a flotation operation that effectively removes the spent friction reducing agents and allows the treated water to be reclaimed and reused as fracturing water, even though it retains levels of contaminants, including boron and methanol, that would prevent its discharge to the environment under existing standards. The treated water may further be treated by removing the methanol via biological digestion in a bioreactor, separating a majority of the contaminants from the water by reverse osmosis and removing the boron that passes through the reverse osmosis system with a boron-removing ion exchange resin.

(56) **References Cited**

U.S. PATENT DOCUMENTS

2,553,900 A * 5/1951 Doan et al. 166/252.6
3,254,719 A 6/1966 Root
4,152,274 A 5/1979 Phillips

17 Claims, 5 Drawing Sheets

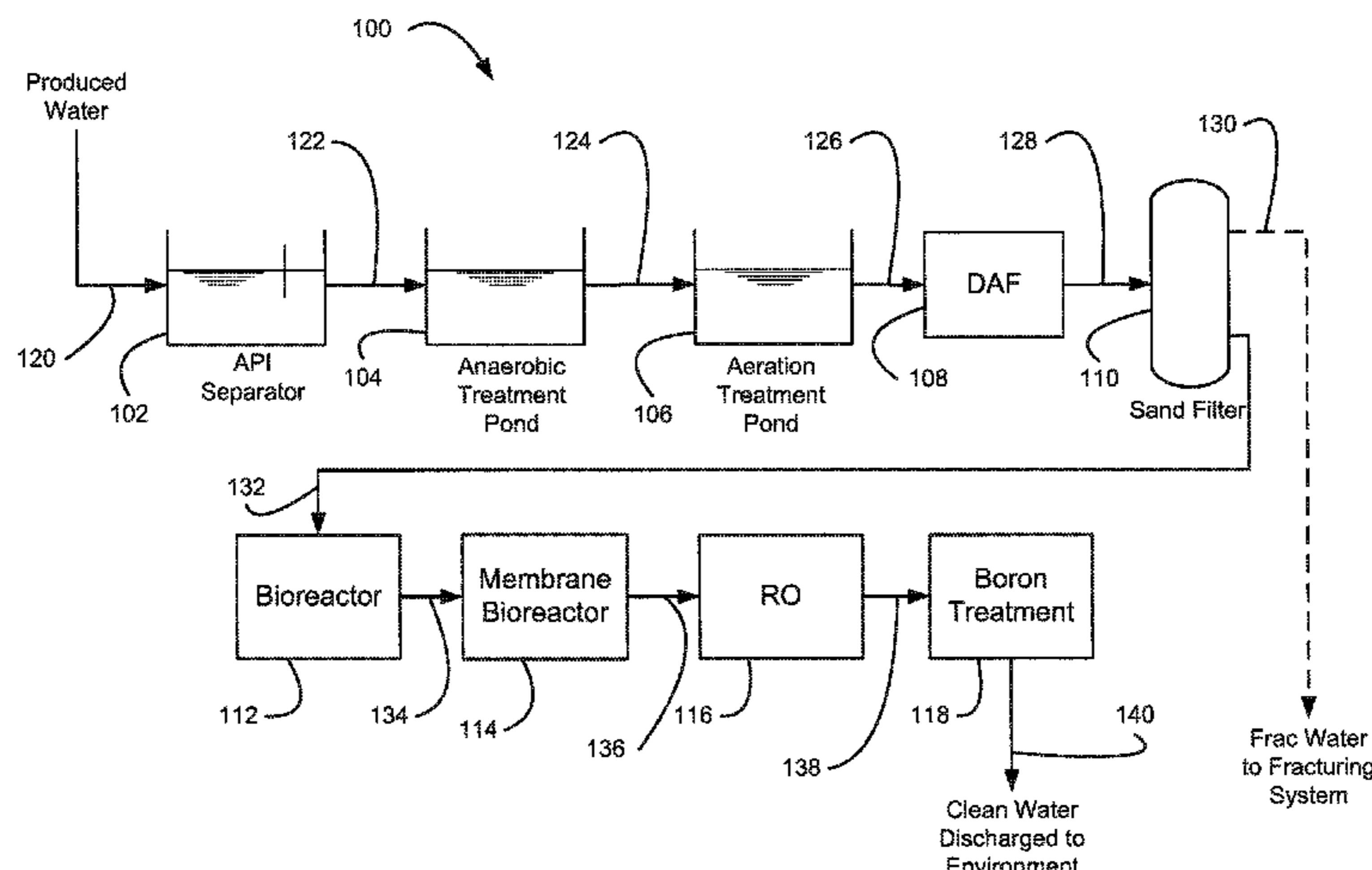

(56)

References Cited

U.S. PATENT DOCUMENTS

5,656,173	A	8/1997	Jordan et al.	
7,442,309	B2 *	10/2008	Wilf et al.	210/652
2004/0031742	A1	2/2004	Arnaud	
2006/0249390	A1	11/2006	Yan et al.	
2007/0051513	A1	3/2007	Heins	
2007/0102359	A1	5/2007	Lombardi	
2008/0290033	A1 *	11/2008	Kimball et al.	210/652
2009/0014368	A1 *	1/2009	Chen et al.	210/109
2009/0308609	A1 *	12/2009	Curole et al.	166/275

OTHER PUBLICATIONS

Dave, Bakul, "Chapter 19: Prospects for Methanol Production," p. 235-245, in "Bioenergy" (2008).*

Funston, R., et al., Kennedy/Jenks Consultants, 200 New Stine Road, Suite 205, Bakersfield, CA 93309, "Evaluation of Technical and Economic Feasibility of Treating Oilfield Produced Water to Create a "New" Water Resource," pp. 1-14, (undated).

Huang, F., et al., "Feasibility of Using Produced Water for Crosslinked Gel-Based Hydraulic Fracturing," 2005 SPE Production and Operations Symposium, Oklahoma City, OK, U.S.A., Apr. 17-19, 2005. pp. 1-12.

Lawrence, A.W., et al., "Evaluation of produced water management option in the natural gas production industry," the SPEC/EPA Exploration and Production Environmental Conference, San Antonio, TX, USA, Mar. 7-10, 1993, pp. 581-595.

Morales, M., et al., "Desalination of Produced Water Using Reverse Osmosis," GasTips, vol. 8, No. 3, pp. 13-17, Summer 2002.

Nable, Ross. O., et al., Plant and Soil, 193 Chpt 12, Boron Toxicity: pp. 181-198, 1997.

Novachis, Lawrence, "Design and Operation of Membrane Bioreactor Technology for Industrial and Municipal Wastewater Treatment,"

WEFTEC 1998 Pre-Conference Workshop, Membrane Technology: Physical and Biological Treatment of Industrial Wastewaters, pp. 1-13.

Tsang, Patrick B., et al "Economic Evaluation of Treating Oilfield Produced Water for Potable Use," SPE International Thermal Operations and Heavy Oil Symposium and Western Regional Meeting, Bakersfield, CA, U.S.A., Mar. 16-18, 2004, pp. 1-16.

BJ Services Company, Material Safety Data Sheet, "MSDS for FRW-14", pp. 1-4. [Date unknown].

Borax™, Agronomy Notes [online]. Borax, 2005, "Relative Plant Tolerance to Available Boron Supply". [retrieved on the internet on Nov. 9, 2007] <<http://www.borax.com/lagriculturefiles/an406.pdf>>.

Dow Chemical Company™, Product Information Sheet, Form No. 177-01997-1103, "XUS-43594.00 A Uniform Particle Size Weak Base Anion Exchange Resin for Selective Boron Removal", pp. 1-2, [Date unknown].

Purolite Ion Exchange Resins, (flyer) "S-108 Boron Selective Anion Exchange Resin (for the removal of boron salts from aqueous solutions)", Form S108_TB/0599, pp. 1-4. [Date unknown].

Sybron Chemicals Inc., a Lanxess Company, Sybron Chemical Products, Product Information, Lewatit™ MK 51, pp. 1-3, [retrieved online on Nov. 9, 2007] <<http://www.sybronchemicals.com/products/selective/index.html>>.

USDA, Agricultural Research Service, US Salinity Laboratory, "Boron Tolerance Limits for Agricultural Crops" pp. 1-3, [online]. [retrieved on the internet on Nov. 9, 2007] <<http://www.ussl.ars.usda.gov/pls/caliche/BOROT46>>.

Zenon Environmental Inc., "The ZeeWeed™ Process Description", Section 1, pp. 1-6, Mar. 18, 2003.

ZeroNet Perspective, Produced Water Project, San Juan Generating Station, power point presentation, 20 pgs., [Date unknown].

Office Action in U.S. Appl. No. 11/685,636, dated Dec. 15, 2008.

Office Action in U.S. Appl. No. 11/685,681, dated Dec. 15, 2008.

Office Action in U.S. Appl. No. 12/399,242, dated Jun. 27, 2011.

* cited by examiner

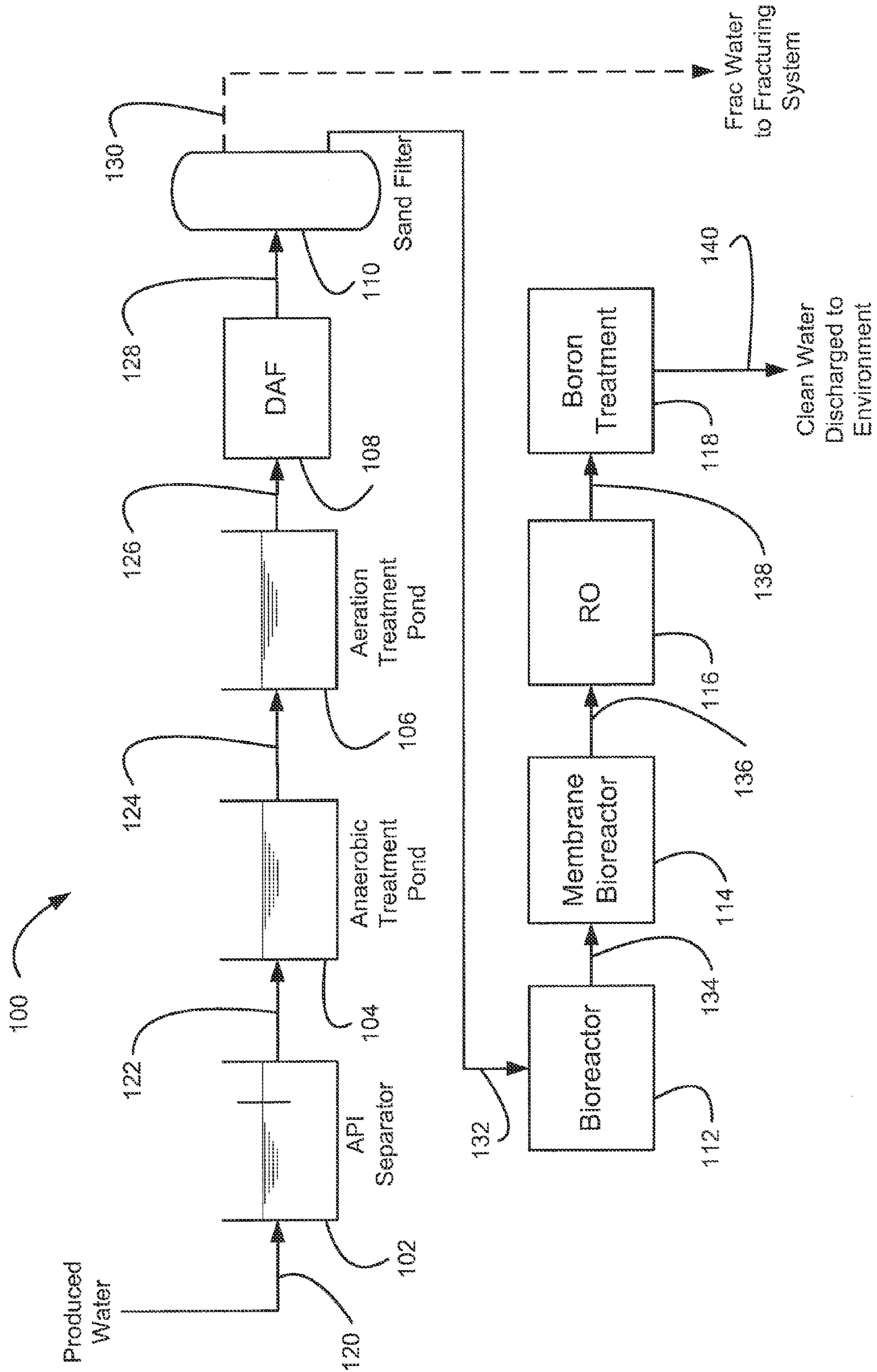

FIG. 1

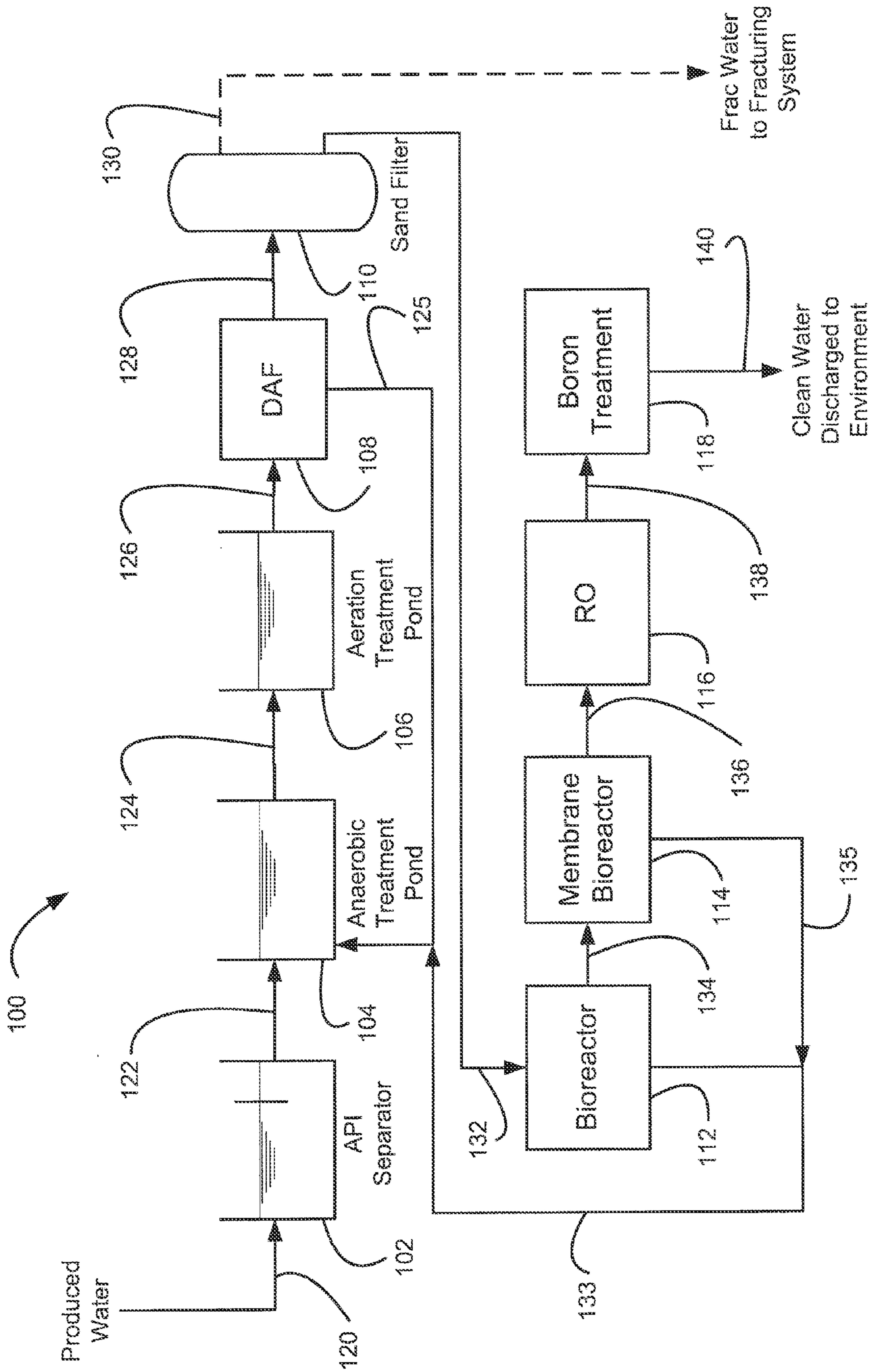

FIG. 2

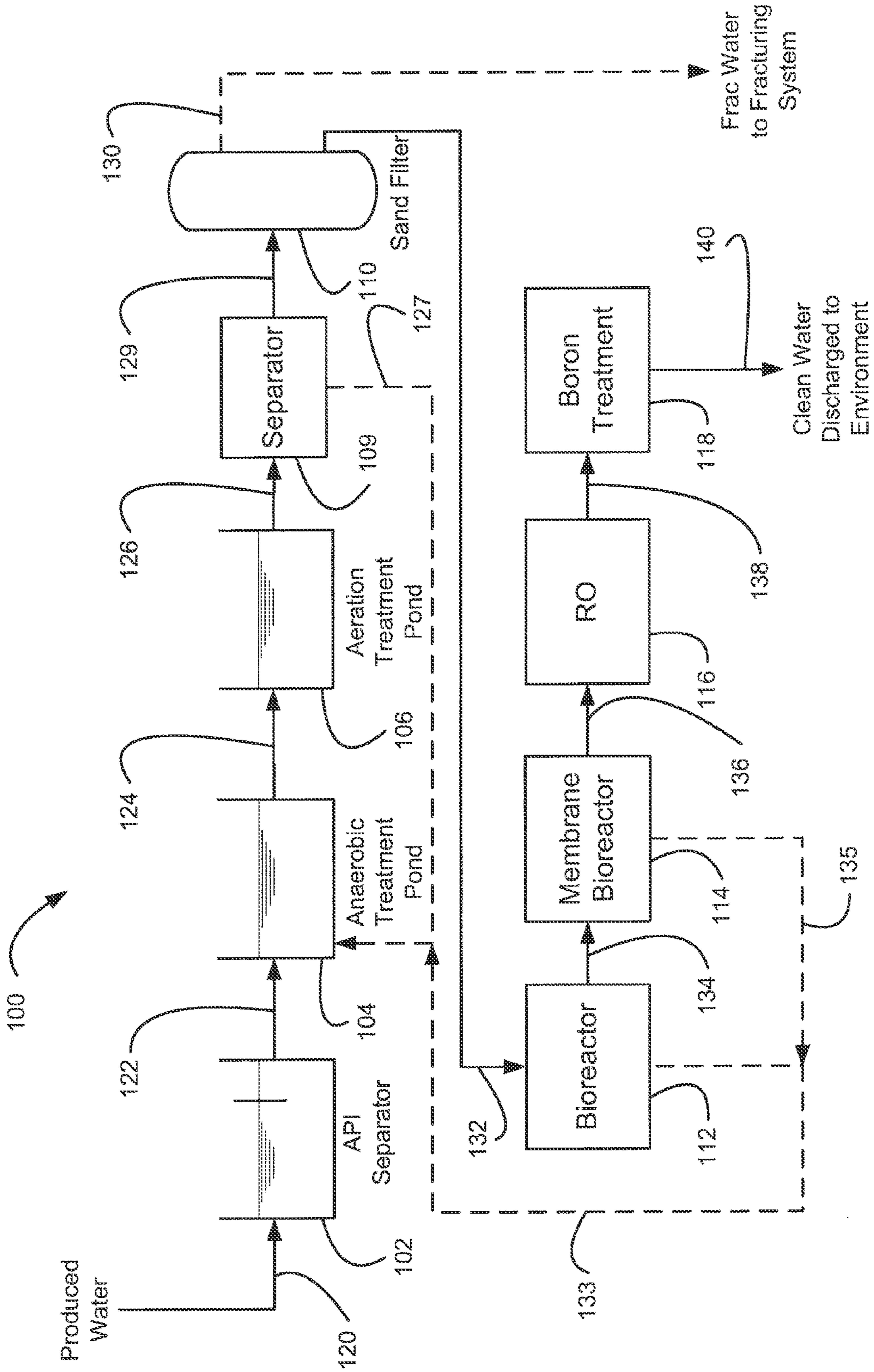

FIG. 3

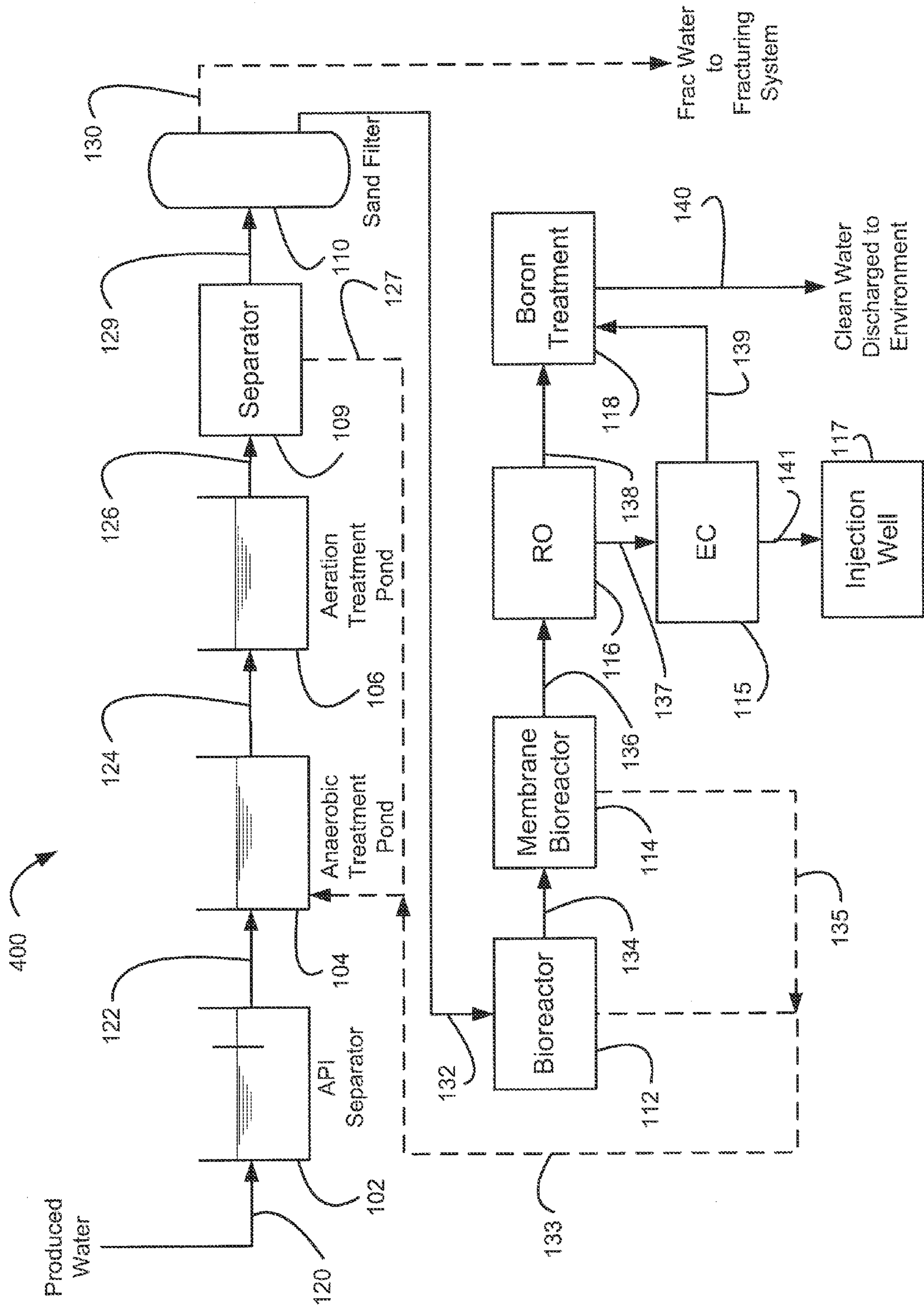

FIG. 4

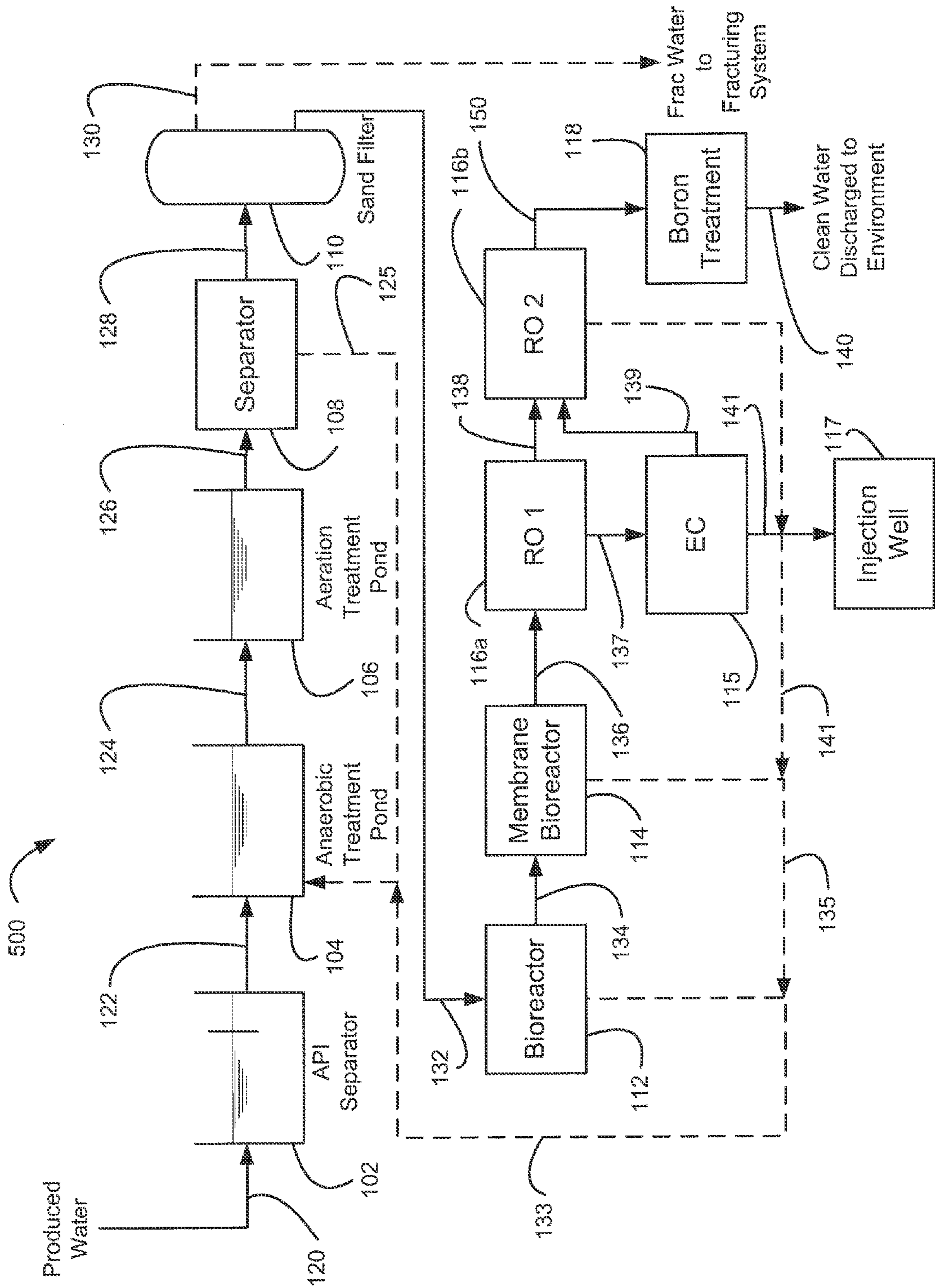

FIG. 5

WASTE WATER TREATMENT METHOD

RELATED APPLICATIONS

This application is a continuation of U.S. Application Ser. No. 12/399,242, filed Mar. 6, 2009, that issued on Jan. 31, 2012, as U.S. Pat. No. 8,105,488, which is a continuation in part of U.S. Application Publication Ser. No. 11/685,663, filed Mar. 13, 2007, that issued on Mar. 31, 2009, at U.S. Pat. No. 7,510,656, which claims the benefit of U.S. Provisional Application No. 60/767,574, filed Sep. 1, 2006, all of which are hereby incorporated herein by reference.

BACKGROUND

Water, especially in the western United States and other arid regions, is a valuable resource. Many oil and natural gas production operations generate, in addition to the desired hydrocarbon products, large quantities of waste water, referred to as “produced water”. Produced water is typically contaminated with significant concentrations of chemicals and substances requiring that it be disposed of or treated before it can be reused or discharged to the environment. Produced water includes natural contaminants that come from the subsurface environment, such as hydrocarbons from the oil- or gas-bearing strata and inorganic salts. Produced water may also include man-made contaminants, such as drilling mud, “frac flow back water” that includes spent fracturing fluids including polymers and inorganic cross-linking agents, polymer breaking agents, friction reduction chemicals, and artificial lubricants. These contaminants are injected into the wells as part of the drilling and production processes and recovered as contaminants in the produced water.

Commonly encountered non-natural contaminants in produced water, and their sources, are discussed below.

From high-viscosity fracturing operations—gellants in the form of polymers with hydroxyl groups, such as guar gum or modified guar-based polymers; cross-linking agents including borate-based cross-linkers; non-emulsifiers; and sulfate-based gel breakers in the form of oxidizing agents such as ammonium persulfate. From drilling fluid treatments—acids and caustics such as soda ash, calcium carbonate, sodium hydroxide and magnesium hydroxide; bactericides; defoamers; emulsifiers; filtrate reducers; shale control inhibitors; deicers including methanol and thinners and dispersants.

From slickwater fracturing operations—viscosity reducing agents such as polymers of acrylamide.

Because of the very wide range of contaminant species as well as the different quality of produced water from different sources, efforts to create a cost effective treatment system that can treat or recycle the spectrum of possible produced water streams have little success. For example, while reverse osmosis is effective in treating many of the expected contaminants in produced water, it is not very effective in removing methanol and it may be fouled by even trace amounts of acrylamide.

As another example, there have been many attempts to reclaim produced water and reuse it as fracturing feed water, commonly referred to as “frac water.” Frac water is a term that refers to water suitable for use in the creation of fracturing (frac) gels which are used in hydraulic fracturing operations. Frac gels are created by combining frac water with a polymer, such as guar gum, and in some applications a cross-linker, typically borate-based, to form a fluid that gels upon hydration of the polymer. Several chemical additives generally will be added to the frac gel to form a treatment fluid specifically designed for the anticipated wellbore, reservoir and operating conditions.

However, some waste water streams are unsuitable for use as frac water in that they require excessive amounts of polymer or more to generate the high-viscosity frac gel. For example, trace amounts of spent friction reducers in the stream inhibit the added polymer from gelling. Because it can be difficult to prevent produced water streams from different sources from being co-mingled, this typically results in all produced water from a well field being made unsuitable for recycling as frac water.

An additional problem occurs when the produced water is also contaminated with methanol and it is desirable to discharge the water to the environment. One way to treat produced water to the extent necessary to discharge the water to the environment, is through filtration techniques such as ultra filtration and reverse osmosis. However, methanol will pass through nearly any available membrane filtration technology.

Yet another problem occurs when the produced water is also contaminated with boron, such as from the use of borate-based cross-linking agents, and it is desirable to discharge the water to the environment. One way to treat produced water with boron is referred to as the HERO® process in which the pH is raised up to at least about 11 prior to treatment with reverse osmosis, resulting in the boron being rejected with the reverse osmosis reject brine. However, raising the pH has several undesirable attributes. First, there is increased scaling within the reverse osmosis system increasing the maintenance costs of the system. Second, the pH must then be reduced before the treated water may be discharged to the environment. Third, the cost of the chemicals to raise the pH coupled with the cost of immediately thereafter lowering the pH and the cost of disposal of the precipitated salts resulting from the lowering of the pH make the HERO® process very expensive.

SUMMARY

Systems and methods have been developed for reclaiming water contaminated with the expected range of contaminants typically associated with produced water, including water contaminated with slick water, methanol and boron. The system includes anaerobically digesting the contaminated water, followed by aerating the water to enhance biological digestion. After aeration, the water is separated using a flotation operation that effectively removes the spent friction reducing agents and allows the treated water to be reclaimed and reused as fracturing water, even though it retains levels of contaminants, including boron and methanol, that would prevent its discharge to the environment under existing standards. The treated water may further be treated by removing the methanol via biological digestion in a bioreactor, separating a majority of the contaminants from the water by reverse osmosis and removing the boron that passes through the reverse osmosis system with a boron-removing ion exchange resin.

In part, this disclosure describes a method for generating fracturing water from produced water. The method includes transferring produced water contaminated with slick water, methanol and boron into an anaerobic pond and holding the produced water in the anaerobic pond for at least a first mean residence time. The method further includes transferring anaerobic pond effluent to an aeration pond and aerating the anaerobic pond effluent in the aeration pond for a second mean residence time. After aeration, the method includes transferring aeration pond effluent from the aeration pond to a dissolved air flotation treatment system and floating the aeration pond effluent with the dissolved air flotation treatment system to generate a floated aqueous effluent and a separated solids effluent. The method further includes bio-

3

logically digesting the floated aqueous effluent in a bioreactor until a desired concentration of methanol is obtained. Then, the bioreactor effluent is transferred from the bioreactor to a reverse osmosis system and contaminants are separated from bioreactor effluent with the reverse osmosis system, wherein the reverse osmosis system passes at least some boron in its permeate. Boron is removed from the reverse osmosis permeate via a boron-selective removal process to obtain a desired level of boron in the reverse osmosis permeate.

In part, this disclosure describes a system for treating water contaminated with methanol and boron. The system includes: an anaerobic digester that receives the water and holds at least a portion of the water under anaerobic conditions; an aerator that aerates the water; a flotation separator that separates contaminants from the water to produce a reclaimed water stream suitable for use as fracturing water; at least one bioreactor that biologically digests methanol in the water until a desired concentration of methanol is obtained; a boron-selective removal system that removes boron from the water until a desired concentration of boron is obtained; and at least one filtration system that removes contaminants from the water with a desired concentration of contaminants other than boron and methanol is obtained.

In part, this disclosure describes a method for removing contaminants from produced water including boron, methanol and contaminants that inhibit the gelling of fracturing fluid. The method includes anaerobically digesting the produced water containing the contaminants for a first period of time and after anaerobically digesting the produced water, aerating the produced water for a second period of time. After aerating the produced water, the produced water is treated by a dissolved air flotation system and the effluent of the dissolved air flotation system is filtered to generate a filtered water containing concentrations of boron and methanol, but that is suitable for use as a fracturing water in that it does not require excessively increased amounts of gellant to create the high-viscosity frac gel. The method further provides for biologically digesting the filtered water, thereby reducing the concentration of methanol in the filtered water and separating contaminants from the filtered water using reverse osmosis, in which the reverse osmosis passes at least some undesirable concentration boron in its permeate. The boron is removed from the reverse osmosis permeate via a boron removing ion exchange resin.

These and various other features as well as advantages will be apparent from a reading of the following detailed description and a review of the associated drawings. Additional features are set forth in the description which follows, and in part will be apparent from the description, or may be learned by practice of the described embodiments. The benefits and features will be realized and attained by the structure particularly pointed out in the written description and claims hereof as well as the appended drawings.

It is to be understood that both the foregoing general description and the following detailed description are exemplary and explanatory and are intended to provide further explanation of the invention as claimed.

BRIEF DESCRIPTION OF THE DRAWINGS

The following drawing figures, which form a part of this application, are illustrative of embodiments systems and methods described below and are not meant to limit the scope of the invention in any manner, which scope shall be based on the claims appended hereto.

FIG. 1 illustrates an embodiment of a system for treating contaminated water;

4

FIG. 2 illustrates an embodiment of a system for treating contaminated water;

FIG. 3 illustrates an embodiment of a system for treating contaminated water;

FIG. 4 illustrates an embodiment of a system for treating contaminated water; and

FIG. 5 illustrates an embodiment of a system for treating contaminated water.

DETAILED DESCRIPTION

Unless otherwise indicated, all numbers expressing quantities of ingredients, properties such as molecular weight, concentrations, reaction conditions, temperatures, and so forth used in the specification and claims are to be understood as being modified in all instances by the term "about." Accordingly, unless indicated to the contrary, the numerical parameters set forth in the following specification and attached claims are approximations that may vary depending upon the desired properties sought to be obtained. At the very least, and not as an attempt to limit the application of the doctrine of equivalents to the scope of the claims, each numerical parameter should at least be construed in the light of the number of reported significant digits and by applying ordinary rounding techniques.

The term "residence time" refers to the average length of time that a fluid or particle spends within a process vessel or in contact with a catalyst. For the purposes of this discussion, the mean residence time of a vessel is defined by dividing the volume of liquid in a vessel (e.g., volume in cubic feet) by the volumetric flow rate of the liquid (e.g., in cubic feet per second).

The term "floating" as used herein refer to Treating a liquid with a flotation operation to separate solid or liquid particles from a liquid phase. There are several types of flotation operations that are well known in the art including dissolved-air flotation (DAF), air flotation and vacuum flotation.

Fracturing gel or "frac gel" refers to a high-viscosity gel fluid mix for use in fracturing a subterranean formation. The term "fracturing gel" will be used herein to refer to a fluid having a viscosity greater than about 100 centipoise when injected into the subsurface for the purpose of fracturing the subsurface formations. The term "Fracturing water," as discussed above, refers to the water to which the gellant is added in order to create the fracturing gel. For the purposes of this disclosure, however, a water is suitable for use as fracturing water if it can be mixed with an economical amount of guar gum, relative to other clean water supplies, to create a frac gel. That is, a water is not suitable for use as fracturing water if it requires significantly more polymer (in order to achieve target properties of the frac gel) than other sources of water readily available. Thus, for the purposes of this disclosure, a water is considered suitable for use as fracturing water only if it can be mixed with an amount of polymer (e.g., guar gum, guar gum derivatives, or other commonly applied gelling agent in the fracturing industry, that will create a frac gel) to create a frac gel having a stable viscosity greater than about 50 centipoise at the injection temperature, and the amount of gelling agent required is no more than about 10% greater than that amount required to create the same viscosity using an equivalently salty water, i.e., distilled water mixed with an equivalent amount of salt content as the purported fracturing water.

Slick water, on the other hand, refers to a relatively low viscosity aqueous fluid used also for fracturing a subterranean formation. The term "slick water" as used herein further refers to low viscosity (i.e., a viscosity less than that used for

5

frac gels) fluid to which friction reduction agents have been added to modify the flow characteristics of the fluid. For example, slick water is often created by adding a small amount of polymer to water in order to change the flow characteristics of the resulting aqueous mixture. Such friction reduction agents include, but are not limited to, polyvinyl polymers, polymethacrylamides, cellulose ethers, polysaccharides, lignosulfonates, and ammonium, alkali metal, and alkaline earth salts thereof. Specific examples of typical water soluble polymers are acrylic acid-acrylamide copolymers, acrylic acid-methacrylamide copolymers, polyacrylamides, partially hydrolyzed polyacrylamides, partially hydrolyzed polymethacrylamides, polyvinyl alcohol, polyvinyl acetate, polyalkyleneoxides, carboxy celluloses, carboxyalkylhydroxyethyl celluloses, hydroxyethylcellulose, galactomannans (e.g., guar gum), substituted galactomannans (e.g., hydroxypropyl guar, carboxymethyl hydroxypropyl guar, and carboxymethyl guar), heteropolysaccharides obtained by the fermentation of starch-derived sugar (e.g., xanthan gum), and ammonium and alkali metal salts thereof. Preferred water-soluble polymers include hydroxyethyl cellulose, starch, scleroglucan, galactomannans, and substituted galactomannans. For example, copolymers of acrylamides are disclosed as good friction reduces in U.S. Pat. Nos. 3,254,719 and 4,152,274, which disclosures are hereby incorporated herein by reference. An example of an acrylamide-based friction reducer includes that sold under the product name FRW-14 by BJ SERVICES COMPANY. Others are well known in the art.

It should be noted that both fracturing fluids and slick water may include other compounds such as demulsifiers, corrosion inhibitors, friction reducers, clay stabilizers, scale inhibitors, biocides, breaker aids, mutual solvents, alcohols, surfactants, anti-foam agents, defoamers; viscosity stabilizers, iron control agents, diverters, emulsifiers, foamers, oxygen scavengers, pH control agents, and buffers, and the like.

When referring to concentrations of contaminants in water or to water properties such as pH and viscosity, unless otherwise stated the concentration refers to the concentration of a sample properly taken and analyzed according to standard Environmental Protection Agency (EPA) procedures using the appropriate standard test method or, where no approved method is available, commonly accepted methods may be used. For example, for Oil and Grease the test method identified as 1664A is an approved method. In the event two or more accepted methods provide results that indicate two different conditions as described herein, the condition should be considered to have been met (e.g., a condition that must be "above pH of about 7.0" and one accepted method results a pH of 6.5 and another in pH of 7.2, the water should be considered to be within the definition of "about 7.0").

FIG. 1 illustrates an embodiment of a system for treating contaminated water. The contaminated water may be produced water **120** generated by oil field operations or waste water from some other industrial or residential source. The system **100** is illustrated and discussed below as a continuous flow system. However, in an alternative embodiment some or all of the processes of the system **100** may be operated as batch processes.

In the embodiment shown, the contaminated water is produced water **120** generated from oil, gas or other subsurface extraction operations. In an embodiment, the **25** produced water is contaminated with methanol and boron derived either from natural sources in the subsurface or added as part of the extraction operations.

In an embodiment, the system of FIG. 1 is anticipated to receive produced water having at least about 7,000 milli-

6

grams per liter (mg/l) of total dissolved solids (TDS), at least about 10 mg/l of boron, and at least about 500 mg/l methanol, although the system could be used to treat less contaminated water as well. Furthermore, as discussed in greater detail below, the effluent of the system **100** is desired to contain less than about 500 mg/l of TDS, less than about 2 mg/l boron, and less than about) mg/l methanol, Preferably, the system **100** can accept any produced water of any quality. In testing, waste water, including produced water with the following ranges of contaminant as provided in Table 1 concentrations, were treated.

TABLE 1

Parameter	Range
TDS @ 180 C., mg/l	up to at least 8830
TSS @ 105 C., mg/l	up to at least 141
Turbidity, NTU	up to at least 239
TOC, mg/l	up to at least 1130
COD, mg/l	up to at least 5750
BOD, mg/l	up to at least 1820
pH	up to at least 7.21
Iron, mg/l	up to at least 0.3
Chloride, mg/l	up to at least 4310
Potassium, mg/l	up to at least 59.2
Calcium, mg/l	up to at least 78.5
Magnesium, mg/l	up to at least 9.1
Sodium, mg/l	up to at least 2750
Sulfate, mg/l	up to at least 26
Carbonate, mg/l	ND as CO ₃
Bicarbonate, mg/l	up to at least 459 as HCO ₃
Boron, mg/l	up to at least 11.6
Methanol, mg/l	up to at least 610

In an embodiment, the produced water **120** may also be contaminated with slick water and thus may contain friction reducers such as acrylamides. Such contaminants are relevant in that they are hard to remove, foul many treatment operations such as reverse osmosis systems, and inhibit the formation of fracturing gels if the contaminant exists in sufficient concentration in fracturing water.

The system **100** is designed in anticipation that the produced water **120** is likely to contain these contaminants at all times or intermittently.

The system **100** receives the produced water **120** and may temporarily store it, such as in a holding tank, before beginning active treatment. The produced water **120** may be received via truck, pipeline, surface flow or any other suitable method. Produced waters **120** from different sources may also be received and co-mingled immediately or independently treated until the anaerobic treatment stage discussed below. As the system is adapted to treat any type of expected contaminant, this is an advantage over other systems that are tailored to specific water qualities from specific wells or sources.

The produced water **120** may be treated with a gravity separator, such as an API separator as shown, to remove immiscible phases of oil and grease. Gravity separation is well known and any suitable gravity separation system, e.g., API separator design, gunbarrel separator or gravity clarifier, may be used.

The aqueous separator effluent **122** then is transferred to the anaerobic treatment system **104** for anaerobic digestion of contaminants. In an embodiment, an anaerobic pond may be used as the anaerobic treatment system or as part of the anaerobic treatment system **104**. Anaerobic ponds are known in the art and refer to a deep pond that maintains anaerobic conditions at depth, except for a shallow (typically less than about 2 feet) surface zone. In an embodiment, some oxygen

may be added to water contained in the anaerobic pond through spray evaporation and ambient contact with air, as long as very little dissolved oxygen is achieved below 2 feet of depth to ensure that the conditions at depth remain anaerobic. In an embodiment, other than mixing incidental to the mixing of the effluent **112** with the contents of the anaerobic treatment system **104** vessel, no additional mixing or aeration is provided by the operators.

The anaerobic treatment system **104** treats the water by anaerobic conversion of organic wastes into carbon dioxide, methane, other gaseous end products, alcohols possibly including methanol, and organic acids. Inorganic wastes may also be anaerobically converted. Some separation will occur in the anaerobic treatment system **104** due to precipitation of converted contaminants as well as via settling. In operation, it was noted that anaerobic digestion served at least two beneficial purposes. First, it typically reduced chemical oxygen demand (COD) by 30% or more and usually by at least 50%. However, it notably did not reduce biological oxygen demand (BOD) by very much. Second, anaerobic digestion reduced the ratio of COD to BOD from the initial value (typically around 3:1) to 2:1 or less.

In an embodiment, the water is treated in the anaerobic treatment system **104** based on residence time. A mean residence time of at least about 50 days has been found to be effective. Larger mean residence times are also effective. In an alternative embodiment, an alternative benchmark or combination of benchmarks may be used to determine if sufficient treatment has occurred, such as a targeted COD reduction relative to the inlet amount (e.g., at least about 15% reduction, or at least about 30% or at least about 50% reduction criteria) or threshold COD to BOD ratio being achieved. A combination benchmark may include a minimum of 50 days residence time and any other benchmark such as COD concentration.

Effluent **124** from the anaerobic treatment system **104** is transferred to an aeration system **106**, which may also be referred to as an aerator **106**. The aeration system **106** actively aerates the water to allow the biological digestion of contaminants in the water over time. In an embodiment, the aeration system **106** treats the water for a mean residence time of at least about 5 days with mean residence times of 5 to 10 days being one treatment target. During treatment, the dissolved oxygen of the system is monitored and the aeration is adjusted to maintain a dissolved oxygen concentration above at least 50% of the solubility limit of oxygen in water at the aeration system **106** temperature, preferable above 75% of the solubility limit and more preferable above 90% of the solubility limit. However, the target dissolved oxygen concentration used may be balanced against the cost of providing the aeration and current throughput needs of the system.

In an embodiment, no supplemental nutrients for bioremediation are added in the aeration treatment step. The amount of aeration may be controlled based on measurement of dissolved oxygen of the water in the aeration system **106**. Aeration may also be controlled based on the effectiveness of the flotation treatment and water quality of the flotation treatment effluent **128**. Submerged combustion heaters, or other heat sources, may be used to raise water temperature as desired, such as in the winter to prevent water freezing if the aerator **106** is an outdoor pond.

In addition to biological digestion, it is believed that some oxidation or other aerobic conversion of some contaminants occurs in the aeration system **106**. In an embodiment, a benchmarks to determine proper aeration may include a minimum residence time at a specific rate of aeration and temperature, a reduction of BOD to below a target threshold (e.g., less than about 1300 mg/l, or more preferably less than about

1000 mg/l), a reduction of sulfate to below 10 mg/l sulfate, a reduction of 50-75% of the input concentration of sulfate in the anaerobic treatment system effluent **124**, and/or reduction in barium to less than 1 mg/l. However, as mentioned above, sufficient aeration is primarily indicated by the effectiveness of the flotation treatment and water quality of the flotation treatment effluent **128**.

In the aeration system **106**, aerobic digestion of trace metals occurs helping to clarify these compounds and serves many beneficial functions. First, aerobic digestion of trace metals occurs helping to clarify these compounds. This was evidenced by analyses of sludge taken with insufficient aeration and sufficient aeration showing that insufficient aeration resulted in leachable barium (determined by the TCLP analysis) being found in the sludge whereas, under conditions of proper aeration, leachable barium was reduced below the detection limit.

Experimental data suggest that the aeration step does reduce the COD and BOD of the water being treated, but, without being bound to any particular theory, the aeration step also appears to cause a change in the nature of the COD which increases the effectiveness of the flotation system **108** in removing contaminants. This was evidenced by experiments in which insufficiently aerated effluent from the aeration system **106** was transmitted to the flotation system **108** and it was found that the flotation system's ability to coagulate and separate contaminants was drastically reduced. Notably, another effect of insufficient aeration observed during testing was that the resulting COD that was passed by the DAF **108** fouled the bioreactor **112**. Proper aeration eliminated this fouling. Without being limited to a particular theory, it is believed that the COD in produced water contaminated with frac flow back water is at least in part due to long chain acrylamide polymers, fragments of frac gel and other stimulation chemicals, that can be floated out in the DAF, but only after conversion by the digestion operations **104**, **106**.

In an embodiment, an aeration pond is used as the aeration system **106**. Aeration ponds are known in the art. An aeration pond is typically a large, shallow earthen basin provided with some means for actively aerating the water contained in the pond. Types of active aeration using air include sprayers that spray the water into the air and forced air injection via diffusers submerged in the pond attached to floating aerators. Many other aeration means are known in the art: any suitable means for aerating the water may be used.

Aeration system effluent **126** is transferred, with heat as needed for proper operation, to a flotation separator **108**. The flotation separator **108** separates solid particles from the aqueous phase by introducing fine gas bubbles into the aqueous phase. The bubbles attach to the particulate matter and the buoyant force of the combination is great enough to cause the particle to rise to the surface and subsequently be skimmed off or otherwise mechanically separated from the aqueous phase.

Flotation separators **108** are well known in the art. In experiments, a dissolved air flotation (DAF) separator was used to float and separate particulates from the aqueous phase; however, there is no reason to believe that other flotation separators, such as air flotation or vacuum flotation systems, may not also be effective. In embodiments that utilize a DAF separator, any suitable DAF design, now known or later developed may be utilized. For example, a three vessel DAF in which coagulant is added in the first vessel, the flocculent is added in the second vessel and the third vessel is the actual flotation chamber in which air is added and separation occurs.

Furthermore, any DAF additives may be used as determined to be experimentally suitable in increasing the effectiveness of the DAF separator in removing contaminants. Commercially available coagulants were used to assist the coagulation and increase the performance of the DAF. In an embodiment, Ashland Chargepac 55 with a dose rate between 100 and 200 ppm was used as the coagulant and flocculent polymer was mixed from Ciba Magnafloc 336 and then diluted to a final dose rate of 2 to 7.5 ppm. Preferably, the DAF separator is operated above 35 degrees F. and more preferably at about 55 degrees F. In an embodiment, the DAF separator is operated as necessary to obtain an effluent **128** with an NTU level of less than about 10 NTU.

In the embodiment shown, the aqueous effluent **128** of the flotation separator **108** is further clarified by passing the effluent **128** through a filtration system **110**. Additionally, the effluent **128** may be monitored, such as via a turbidity meter, conductivity sensor or other monitoring device. If the observed level does not meet the desired level of treatment, the effluent **128** may be recycled to an earlier treatment operation. Furthermore, at any point after the aerobic digestion, a biocide may be introduced to eliminate microbes and promote removal of same, such as in the DAF separator **108** or the filtration system **110** or prior to shipment to a frac system.

In the embodiment shown, a sand filter, nominally effective as a 10 micron filter, was used as the filtration system **110** to achieve a turbidity of less than about 5 NTU and preferably less than about 1 NTU. Other filtration designs may also be used. Effluent **128** from the DAF separator **108** may be feed via gravity through the filters **110** to a lift station that transfers water to one or more intermediate surge tanks. In order to achieve the desired level of treatment, one or more separate filters may be utilized in series or in parallel. In an embodiment, each sand filter may be equipped with a sight glass, to show the operator how much head is developing in the filter and also with an inline turbidity meter to directly measure filter performance. When the feed water level in the filter reaches the high tank level switch a backwash cycle may be initiated by a programmable Logic controller (PLC) that monitors operation of the filters or the system as whole. The back wash cycle may also be triggered manually or based on the readings of the turbidity meter. Back wash water and overflow from the sand filter inlet may be recycled to any prior treatment operation as desired by the operator.

The effluent **130**, **132** of the filtration system **110** is suitable for use as a fracturing water even though in experiments it still contained significant concentrations of COD, total organic carbon (TOC), TDS, and biological oxygen demand (BOD). Its use as a fracturing water was evidenced by the ability to gel sufficiently when combined with polymers to create a high-viscosity fracturing gel. Without being bound to a particular theory, it is believed that trace amounts of the friction reducers from slick water impair the gelling reaction. These friction reducers are also very difficult to remove using either anaerobic or aerobic treatment alone and also difficult to remove without the use of flotation. Indeed, it is believed the combination of anaerobic, aerobic and flotation treatment operations is the most effective way of reclaiming produced water that is unsuitable for use as fracturing water and convert it into water that is suitable for use as a fracturing water.

Typical and target values of contaminant concentrations for fracturing water **130**, **132** obtained from the system **100** are provided below in Table 2.

TABLE 2

Parameter	Range	Target
TDS @ 180 C., mg/l	9,000-16,000	<10,000
TSS @ 105 C., mg/l	0-100	<75
Turbidity, NTU	0-5	<1
TOC, mg/l	400-800	<700
COD, mg/l	1000-3000	<2000
BOD, mg/l	500-1500	<1000
pH	6.5-8	7-7.5
Iron, mg/l	1-10	<5
Chloride, mg/l	5,000-10,000	<6,000
Potassium, mg/l	100-500	<300
Calcium, mg/l	50-250	<150
Magnesium, mg/l	10-100	<25
Sodium, mg/l	2000-5000	<3000
Sulfate, mg/l	40-200	<50
Carbonate, mg/l	0-100	<25
Bicarbonate, mg/l	100-1200	<800
Boron, mg/l	0-20	<15

In the embodiment shown in FIG. 1, in addition to generating water suitable for reuse as fracturing water, additional treatment operations are provided that treat the produced water to a quality sufficiently clean for discharge to the environment. Thus, depending on the need for frac water, the system **100** may be operated so that more or less frac water **130** is produced from the produced water **120** stream. Any surplus of unused frac water **130** may then be treated by the remaining portions of the system **100** to a water quality that allows the water to be discharged to the environment. Treatment of the frac water **130**, **132** to a quality suitable for discharge to the environment requires that the system **100** address methanol and boron concentrations. Methanol is often a contaminant in produced water. In addition, anaerobic digestion may produce methanol from the digestion of guar gels. Testing has shown that in the system shown in FIG. 1 while some methanol reduction (e.g., at the top of the pond) may occur under certain conditions during the anaerobic treatment operation, methanol may be treated significantly during the aeration treatment. However, the aeration system **106** as described can not be depended upon to sufficiently treat all of the methanol in the produced water. This variability may be due to lack of nutrients, composition of the particular inlet produced water being treated or the ambient weather conditions under which the aeration treatment is being operated.

In the embodiment shown, the system **100** further provides for the effluent **132** of the filtration operation to be transferred to one or more bioreactors **112**, **114** for the biological digestion of the effluent **132**. Biological digestion of the effluent **132** drastically reduces the concentration of the methanol in the water. In an embodiment, the biological digestion of the effluent **132** is performed for a duration sufficient to reduce the methanol to below the target discharge limit or alternatively to a level at which the methanol can no longer be detected.

In the embodiment shown, two stages of biological digestion are performed. First, a bioreactor **112** may be used to perform the majority of the biological digestion. In an embodiment, the bioreactor may be an enclosed vessel, such as a steel tank with internal epoxy coating and standard tank roof with appropriate vents. Coarse bubble diffusers may be mounted on the bottom of the tank with air supplied by compressors. The bioreactor **112** may or may not be heated as needed to maintain a healthy biological environment for digestion. Additionally, nutrients may be added, such as gaseous ammonia for nitrogen and phosphoric acid for phosphorous, as necessary. In an embodiment, a residence time tray be

11

chosen so that methanol is completely eliminated or reduced to a desired concentration in the bioreactor 112. The design and operation of bioreactors are well known in the art and any suitable design may be utilized as part of this operation.

In the embodiment shown, a second, and optional, stage of combined biological digestion and filtration is provided in which the effluent 134 of the bioreactor 112 is transferred to a membrane bioreactor (MBR) 114 as shown. The MBR 114 provides additional biological digestion as well as removing by filtration some contaminants contributing to TOC concentrations in the water 134. Cleaned water (permeate 136) is extracted through the membranes of the MBR 114. In an embodiment, reject from the MBR 114 may be returned to the bioreactor 112 for additional digestion or to any other prior treatment stage. Any suitable membrane bioreactor design may be utilized, for example a hollow fiber membrane bioreactor such as that sold by ZENON under the trademark ZEEWEED is suitable for use as the MBR 114.

Permeate 136 of the MBR 114 is transferred to an RO system. In the embodiment shown, a reverse osmosis (RO) system 116 is used to filter the remaining, TOC, TDS and other contaminants from the permeate 136 to a level acceptable for discharge, except boron. RO systems 116 are well known in the art and any design, now known or later developed, may be utilized.

Notably, where the pH of the water is not raised, such as for the purposes of precipitating out contaminants, in the prior operations such as is necessary in the HERO® process. In an embodiment, there may be some minor reduction of pH in order to maintain the proper conditions within the bioreactor. This, however, does not cause the precipitation of any contaminants, but rather increases the solubility of some contaminants. The pH of the RO permeate 138 will be dictated primarily by the pH of the produced water 120. Thus, the pH of the RO permeate 138 will generally be much lower than the permeate of the RO in a HERO® process. Preferably the RO permeate 138 in the system 100 will be less than about 10.0, still yet less than about 9.0 and even more advantageously less than about 8.0 and greater than about 6.5.

By avoiding lime softening, the production of waste solids by the system 100 is significantly lower in comparison. Other than solids derived from the original contaminants in the produced water feed, the major source of solids generated as a result of the treatment operations is due the use of liquid coagulant in the DAF. This represents a significant cost savings over systems and processes that actively adjust the pH through chemical addition as part of the treatment.

However, because of the pH range at which the RO 116 is operated as described above, boron will not be removed from the water by the RO system 116 in quantities sufficient to meet the desired discharge concentration. In experimental analyses, MBR effluent 136 contained roughly the same concentration of boron as the produced water 120. The RO system 116 is expected to pass a significant portion of the boron in the stream—a portion that is expected to be beyond the limits necessary to discharge the boron to the environment.

In the system 100 of FIG. 1, boron is removed from the RO permeate 138 by means of a boron-selective treatment system 118. In an embodiment, the boron selective treatment system 118 is an ion-exchange resin adapted to optimally remove boron from an otherwise relatively clean aqueous stream. One example of such a resin suitable for use in the systems described herein is that offered by Dow Chemical under the trade name of XUS-43594.00, now alternately referred to under the trade name BSR1, which is marketed as a uniform particle size weak base anion exchange resin for selective boron removal. Other boron-selected resins known in the art

12

include the product MK-51 sold by SYBRON and S-108 sold by PUROLITE. Other systems that are effective for removing boron may also be used, whether now known or later developed. In fact, because the RO permeate 138 is substantially clean except for the boron, any effective boron removal system may be used without worry of fouling or degradation due to other contaminants.

Effluent 140 of the boron-selective treatment system 118 will be of sufficient quality to be discharged to the environment. Exemplified target values of contaminant concentrations for effluent 140 from an embodiment of the system 100 are provided below in Table 3. If, upon testing, the values are outside of the target ranges, the effluent 140 may be recycled to one of the treatment operations until the effluent 140 quality meets the discharge requirements.

TABLE 3

Parameter	Range
TDS	<500 mg/l
TOC	<5 mg/l
Boron	1-2 mg/l
pH	6.5-9.0
Oil & Grease	<10 mg/l
Radium 226	<60 mg/l
Chlorides	<230 mg/l

Various waste streams other than the primary aqueous streams discussed may be disposed in any suitable manner. For example, reject from the RO system 116 may be used as backwash for prior treatment systems, shipped to the oilfield for use as eras water, returned to the treatment flow for reprocessing and further concentration or disposal via injection well. As a further example, in embodiments using an ion-exchange resin for boron removal, the boron-laden regenerate from the ion-exchange regeneration may be blended with RO reject fluid to neutralize the regenerate and injected in the disposal well.

In an embodiment, some or all of the operations of the treatment system may be automated using process controllers, automated transfer pumps, flow control valves, sensors and other equipment as is known in the art.

The fracturing water 130 output of the system 100 may be stored in holding tanks prior to transfer to a Fracturing gel production system via pipeline or truck to a wellhead or other location where fracturing chemicals are added to generate fracturing gel. Similarly, the boron-selective treatment system effluent may be discharged to a holding tank for confirmation testing prior to discharge.

In another embodiment, the flotation separator 108 or DAF may be replaced with a different type of solid/liquid separator 109 as illustrated in FIG. 3. In this embodiment, the aeration system effluent 126 may be transferred, with heat as needed for proper operation, to the separator 109. The separator 109 separates solid particles from the aqueous phase. Depending on the chemical makeup of the aeration system effluent 126 being treated any of the typical separation processes may be used, including solids thickening, gravity separation, filtration, and centrifugation.

In one embodiment, the solid/liquid separator 109 allows solid particles to settle at the bottom of a tank where the solid particles are removed. Any suitable solid/liquid separation device and/or process may be utilized, such as a clarifier or a primary sedimentation tank. A clarifier separates solid particles from an aqueous phase by flocculation. Flocculation refers to the process by which fine particulates are caused to clump together into floc. The floc may then float to the top of

the liquid, settle to the bottom of the liquid, or can be readily filtered from the liquid for separation.

Solid/liquid separators **109** are well known in the art. In experiments, a DAF separator was used to separate particulates from the aqueous phase; however, depending on the quality of the aeration system effluent **126** the resulting floc sometimes was lighter than water and was removed from the top of the separator **109** and sometimes was heavier than water and was removed from the bottom of the separator **109**. There is no reason to believe that other separator designs, such as an inclined plate clarifier, circular center feed clarifier or sedimentation tank separator, may not also be effective. In embodiments that utilize a separator, any suitable separator design, now known or later developed, may be utilized.

Furthermore, any additives may be used as determined to be experimentally suitable in increasing the effectiveness of the separator **109** in removing contaminants. Commercially available coagulants may be utilized to assist the coagulation and increase the performance of the solid/liquid separator **109**. In an embodiment, the separator **109** is operated as necessary to obtain an effluent **129** with an NTU level of less than about 10 NTU.

In the embodiment shown, the aqueous effluent **129** of the separator **109** is further clarified by passing the effluent **129** through a filtration system **110**. Additionally, the effluent **129** may be monitored, such as via a turbidity meter, conductivity sensor or other monitoring device. If the observed level does not meet the desired level of treatment, the effluent **129** may be recycled to an earlier treatment operation.

In one embodiment, the solids **127** from the solid/liquid separator **109** or the solids **125** from the flotation separator **108** are recycled back to the anaerobic treatment pond **104** as illustrated in FIGS. 2 through 5. Furthermore, at any point after the aerobic digestion, a biocide may be introduced to eliminate microbes and promote removal of same, such as in the solid/liquid separator **109** or the filtration system **110** or prior to shipment to a frac system. In another embodiment, the solids **133** of the bioreactor **112** are recycled back to the anaerobic treatment pond **104** as illustrated in FIGS. 2 through 5. In a further embodiment, the solids **135** from the MBR **114** are recycled back to the anaerobic treatment pond **104** as illustrated in FIGS. 2 through 5.

FIGS. 4 and 5 illustrate embodiments of water treatment systems utilizing an electrocoagulation (EC) system in conjunction with the RO system in order to further decrease the amount of system concentrate that must be disposed via the injection well. FIGS. 4 and 5 differ in how in the EC system **115** is integrated with the RO system **116**. in FIG. 4, the EC system **115** treats all of the RO reject **137**, while in FIG. 5, the EC system **115** treats only a portion of the RO reject from a first RO system **116a** which is then returned to the second RO system **116b** for further treatment.

In FIGS. 4 and 5, an injection well **117** is used to dispose of the system waste system that cannot be recycled. In order to reduce the volume of system waste being sent to the injection well **117**, the electrocoagulation (EC) system **115** is used to further concentrate the RO effluent **137**. The EC system **115** is designed to remove metals, colloidal solids, particles, and soluble inorganic pollutants from an aqueous media by introducing highly charged polymeric metal hydroxide species. These species neutralize the electrostatic charges on suspended solids and oil droplets to facilitate agglomeration or coagulation and resultant separation from the aqueous phase. The treatment prompts the precipitation of certain metals and salts.

In one embodiment, the EC system **115** is made up of an electrolytic cell with at least one anode and cathode. When

connected to an external power source, the anode material will electrochemically corrode due to oxidation, while the cathode will be subjected to passivation. During electrolysis, the positive side undergoes anodic reactions, while on the negative side, cathodic reactions are encountered. Consumable metal plates, such as iron or aluminum, may be utilized as sacrificial electrodes to continuously produce ions in the water. The released ions neutralize the charges of the particles and thereby initiate coagulation. The released ions remove undesirable contaminants either by chemical reaction and precipitation, or by causing the colloidal materials to coalesce, which can then be removed by flotation. In addition, as water containing colloidal particulates, oils, or other contaminants moves through the applied electric field, there may be ionization, electrolysis, hydrolysis, and free-radical formation which can alter the physical and chemical properties of water and contaminants. As a result, the reactive and excited state causes contaminants to be released from the water and destroyed or made less soluble. EC is a process known in the art and any suitable EC system or technology, now known or later developed, may be employed herein without departing from the scope of this disclosure.

The EC system **115** produces a treated EC effluent **139** and an EC waste stream **141**. In the embodiment illustrated in FIG. 4, the EC waste stream **141** is disposed via the injection well **117**. Alternatively (not shown), the EC waste stream **141** may be recycled to one of the prior stages such as the anaerobic treatment pond **104** or further concentrated using thermal processes (e.g., evaporation).

FIG. 5 illustrates an alternative embodiment in which the EC system **115** is used to process the first RO system **116a** reject **137** so that the water can then be reprocessed through an additional RO system **116b** at higher pressures without fouling. The permeate **150** from the second RO system **116b** can be sent to the boron removal as shown or, alternatively, directly used for industrial water in applications do not require a low concentration of boron. In an embodiment, the reject **150** from those additional RO steps is approaching the pressure limit of RO.

In this embodiment, the resulting solids **141** separated from the aqueous solution of the EC system **115** are fed into the injection well **117** and/or recycled back into the anaerobic treatment pond **104**.

Those skilled in the art will recognize that the methods and systems of the present disclosure may be implemented in many manners and as such are not to be limited by The foregoing exemplary embodiments and examples. In other words, functional elements being performed by a single or multiple components, in various combinations. In this regard, any number of the features of the different embodiments described herein may be combined into single or multiple embodiments, and alternate embodiments having fewer than or more than all of the features herein described are possible.

While various embodiments have been described for purposes of this disclosure, various changes and modifications may be made which are well within the scope of the present invention. For example, between one or more of the treatment operations described herein, transfer pumps, surge tanks, control valves, heaters, and other equipment may be provided to assist the efficient operation and maintenance of the system and to provide for various contingencies such as surges, cleaning operations, recycling of flow, bypassing of operations, and low or high ambient temperatures. As a specific example, water being transferred between any two operations may be analyzed and recycled to a previous stage if certain contaminant concentrations are out of a predetermined desired range. Additionally, if the system is operated as a

continuous flow system, surge tanks and overflow capacity may be provided at different points within the system to allow for the system throughput to be managed as necessary to obtain the proper water quality at each stage of treatment.

Numerous other changes may be made which will readily suggest themselves to those skilled in the art and which are encompassed in the spirit of the invention disclosed and as defined in the appended claims.

What is claimed is:

1. A method treating produced water comprising: anaerobically treating produced water for at least a first mean residence time; aerating the produced water for a second mean residence time; biologically digesting the anaerobically treated and aerated produced water to produce a digested effluent having a desired concentration of methanol; separating contaminants from the digested effluent with one or more of a reverse osmosis system and an ultra filtration system to produce a filtered effluent and a reject stream; and concentrating at least some of the reject stream to produce a concentrated reject stream, wherein the concentrating operation includes evaporating at least some of the reject stream.
2. The method of claim 1, wherein the filtered effluent contains at least some boron.
3. The method of claim 1, wherein the produced water contains boron and the method further comprises: removing at least some of the boron from the filtered effluent via an ion-exchange resin selected for the removal of boron to obtain boron treatment system effluent having a desired level of boron.
4. The method of claim 1 further comprising: receiving the produced water at a first pH less than about 10.0; and wherein the steps of claim 1 are performed on water at a pH less than about 10.0.
5. The method of claim 1 further comprising: separating contaminants from the digested effluent with a desalination system to obtain a desalination effluent having a concentration of salt less than a desired concentration of salt.
6. The method of claim 1 wherein the biologically digesting operation removes a concentration of methanol to achieve the desired concentration of methanol, wherein at least some of the methanol removed by the biologically digesting operation is generated as part of the anaerobically treating operation.
7. The method of claim 1 further comprising: injecting the concentrated reject stream into a disposal well.
8. A method treating produced water comprising: anaerobically treating produced water for at least a first mean residence time;

aerating the produced water for a second mean residence time;

biologically digesting the produced water; and concentrating the anaerobically treated, aerated and digested produced water to produce a concentrated stream, wherein the concentrating operation includes evaporating at least some of the anaerobically treated, aerated and digested produced water.

9. A method treating produced water comprising: anaerobically treating produced water for at least a first mean residence time; aerating the produced water for a second mean residence time; biologically digesting the produced water; concentrating the anaerobically treated, aerated and digested produced water to produce a concentrated stream; and injecting the concentrated stream into a disposal well.

10. The method of claim 8 further comprising: separating contaminants from the anaerobically treated, aerated and digested produced water with a filtration system.

11. A method treating produced water comprising: anaerobically treating produced water for at least a first mean residence time; aerating the produced water for a second mean residence time;

biologically digesting the produced water; concentrating the anaerobically treated, aerated and digested produced water to produce a concentrated stream; and removing immiscible phase hydrocarbons from the produced water.

12. The method of claim 11 wherein the removing operation is performed before the anaerobically treating, aerating, and biologically digesting operations.

13. The method of claim 11 wherein the removing operation is performed using a gravity separator.

14. A method treating produced water comprising: anaerobically treating produced water for at least a first mean residence time; aerating the produced water for a second mean residence time;

biologically digesting the produced water; concentrating the anaerobically treated, aerated and digested produced water to produce a concentrated stream; and

injecting the concentrated stream into a disposal well.

15. The method of claim 14 further comprising: removing immiscible phase hydrocarbons from the produced water.

16. The method of claim 15 wherein the removing operation is performed before the anaerobically treating, aerating, and biologically digesting operations.

17. The method of claim 15 wherein the removing operation is performed using a gravity separator.

* * * * *