



US008512318B2

(12) **United States Patent**
Tovey et al.

(10) **Patent No.:** **US 8,512,318 B2**
(45) **Date of Patent:** ***Aug. 20, 2013**

(54) **ROBOTIC ARMS DLUS FOR PERFORMING SURGICAL TASKS**

(75) Inventors: **H. Jonathan Tovey**, Monore, CT (US);
Keith Ratcliff, Newton, CT (US);
Kenneth E. Toso, Wilton, CT (US);
Peter W. J. Hinchliffe, New Haven, CT (US)

(73) Assignee: **Covidien LP**, Mansfield, MA (US)

(*) Notice: Subject to any disclaimer, the term of this patent is extended or adjusted under 35 U.S.C. 154(b) by 0 days.

This patent is subject to a terminal disclaimer.

(21) Appl. No.: **13/191,560**

(22) Filed: **Jul. 27, 2011**

(65) **Prior Publication Data**

US 2011/0282360 A1 Nov. 17, 2011

Related U.S. Application Data

(60) Continuation of application No. 11/928,053, filed on Oct. 30, 2007, which is a continuation of application No. 10/851,819, filed on May 21, 2004, now abandoned, which is a continuation of application No. 09/804,531, filed on Mar. 12, 2001, now Pat. No. 6,827,712, which is a division of application No. 09/099,740, filed on Jun. 18, 1998, now Pat. No. 6,231,565.

(60) Provisional application No. 60/049,923, filed on Jun. 18, 1997.

(51) **Int. Cl.**
A61B 19/00 (2006.01)

(52) **U.S. Cl.**
USPC **606/1; 606/130**

(58) **Field of Classification Search**

USPC 606/1, 130, 139
See application file for complete search history.

(56) **References Cited**

U.S. PATENT DOCUMENTS

4,411,266	A	10/1983	Cosman	
4,508,253	A	4/1985	Green	
4,565,200	A	1/1986	Cosman	
4,604,787	A *	8/1986	Silvers, Jr.	483/55
4,655,630	A	4/1987	Rinehart	
4,907,589	A	3/1990	Cosman	
4,921,393	A	5/1990	Andeen et al.	
4,955,862	A	9/1990	Sepetka	
4,966,597	A	10/1990	Cosman	
4,979,949	A *	12/1990	Matsen et al.	606/53

(Continued)

FOREIGN PATENT DOCUMENTS

EP 064731 A2 4/1995

Primary Examiner — Bill Thomson

Assistant Examiner — Jeffrey Lipitz

(57) **ABSTRACT**

Disposable loading units (DLUs) configured for mounting to a robotic arm for performing at least one surgical task are presented. Each DLU includes an attachment platform having at least one connector for engaging at least one connector on a distal end of the robotic arm for connecting the DLU to the robotic arm, a head portion connected to the attachment platform at one end and configured for housing an electromechanical actuation assembly therein, and at least one surgical tool member extending from the head portion and operatively associated with the electromechanical actuation assembly for controlling the operation and movement of the at least one surgical tool member. The at least one surgical tool member may include a cutting assembly, an aortic hole punch assembly, a lasing assembly, a coring assembly, or a vascular suturing assembly.

24 Claims, 8 Drawing Sheets

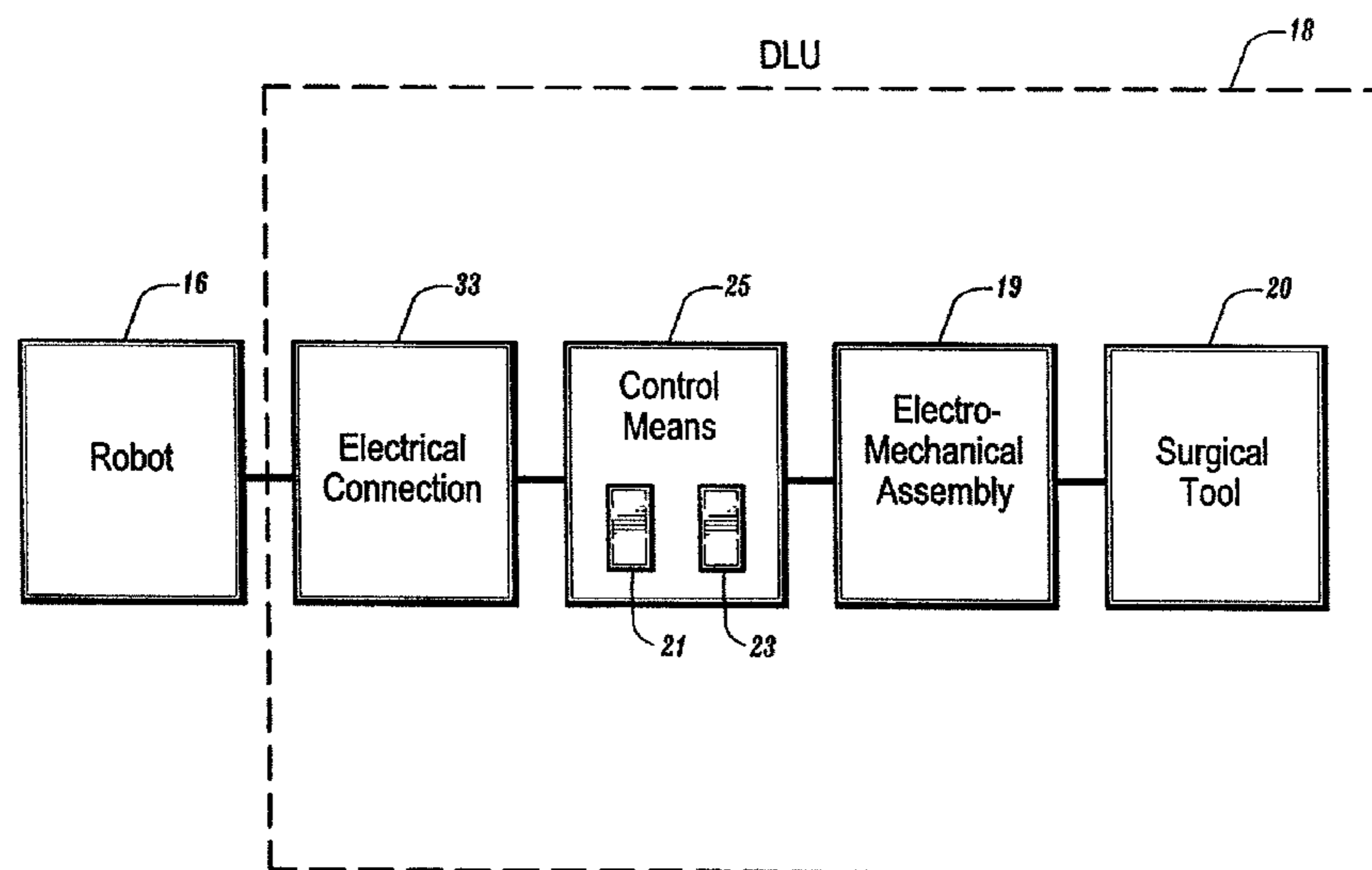

(56)

References Cited

U.S. PATENT DOCUMENTS

5,040,715 A	8/1991	Green et al.	5,797,900 A	8/1998	Madhani et al.
5,084,057 A	1/1992	Green et al.	5,800,423 A	9/1998	Jensen
5,095,915 A	3/1992	Engelson	5,807,377 A	9/1998	Madhani et al.
5,122,137 A	6/1992	Lennox	5,814,038 A	9/1998	Jensen et al.
5,154,717 A	10/1992	Matsen, III et al.	5,815,640 A	9/1998	Wang et al.
5,187,796 A	2/1993	Wang et al.	5,820,623 A	10/1998	Ng
5,236,432 A	8/1993	Matsen, III et al.	5,833,632 A	11/1998	Jacobsen et al.
5,289,963 A	3/1994	McGarry et al.	5,841,950 A	11/1998	Wang et al.
5,300,081 A	4/1994	Young et al.	5,855,583 A	1/1999	Wang et al.
5,304,131 A	4/1994	Paskar	5,871,523 A	2/1999	Fleischman et al.
5,315,996 A	5/1994	Lundquist	5,907,664 A	5/1999	Wang et al.
5,329,923 A	7/1994	Lundquist	5,911,036 A	6/1999	Wright et al.
5,334,145 A	8/1994	Lundquist et al.	5,951,546 A	9/1999	Lorentzen
5,391,144 A	2/1995	Sakurai et al.	5,971,976 A	10/1999	Wang et al.
5,397,323 A	3/1995	Taylor et al.	5,980,504 A	11/1999	Sharkey et al.
5,403,311 A	4/1995	Abele et al.	5,983,141 A	11/1999	Sluijter et al.
5,403,328 A	4/1995	Shallman	6,001,093 A	12/1999	Swanson et al.
5,433,739 A	7/1995	Sluijter et al.	6,004,279 A	12/1999	Crowley et al.
5,437,288 A	8/1995	Schwartz et al.	6,007,550 A	12/1999	Wang et al.
5,441,483 A	8/1995	Avitall	6,007,570 A	12/1999	Sharkey et al.
5,445,166 A	8/1995	Taylor	6,017,354 A	1/2000	Culp et al.
5,470,006 A	11/1995	Rodak	6,024,695 A	2/2000	Taylor et al.
5,477,856 A	12/1995	Lundquist	6,048,339 A	4/2000	Zirps et al.
5,478,344 A	12/1995	Stone et al.	6,063,095 A	5/2000	Wang et al.
5,497,785 A	3/1996	Viera	6,073,051 A	6/2000	Sharkey et al.
5,515,478 A	5/1996	Wang	6,095,149 A	8/2000	Sharkey et al.
5,524,180 A	6/1996	Wang et al.	6,099,514 A	8/2000	Sharkey et al.
5,536,267 A	7/1996	Edwards et al.	6,099,541 A	8/2000	Klopotek
5,545,193 A	8/1996	Fleischman et al.	6,102,850 A	8/2000	Wang et al.
5,545,200 A	8/1996	West et al.	6,122,549 A	9/2000	Sharkey et al.
5,553,198 A	9/1996	Wang et al.	6,126,682 A	10/2000	Sharkey et al.
5,571,110 A	11/1996	Matsen, III et al.	6,132,368 A	10/2000	Cooper
5,571,147 A	11/1996	Sluijter et al.	6,132,441 A	10/2000	Grace
5,573,520 A	11/1996	Schwartz et al.	6,146,380 A	11/2000	Racz et al.
5,624,398 A	4/1997	Smith et al.	6,161,048 A	12/2000	Sluijter et al.
5,645,520 A	7/1997	Nakamura et al.	6,231,565 B1	5/2001	Tovey et al.
5,657,429 A	8/1997	Wang et al.	6,264,650 B1	7/2001	Hovda et al.
5,728,149 A	3/1998	Laske et al.	6,346,072 B1	2/2002	Cooper
5,746,701 A	5/1998	Noone	6,364,888 B1	4/2002	Niemeyer et al.
5,748,767 A	5/1998	Raab	6,436,107 B1	8/2002	Wang et al.
5,754,741 A	5/1998	Wang et al.	6,463,361 B1	10/2002	Wang et al.
5,762,458 A	6/1998	Wang et al.	6,496,099 B2	12/2002	Wang et al.
5,782,571 A	7/1998	Hufford et al.	6,827,712 B2	12/2004	Tovey et al.
5,785,705 A	7/1998	Baker	8,005,571 B2	8/2011	Sutherland et al.
5,792,135 A	8/1998	Madhani et al.	8,041,459 B2	10/2011	Sutherland et al.
			8,100,896 B2	1/2012	Podhajsky
			8,170,717 B2	5/2012	Sutherland et al.

* cited by examiner

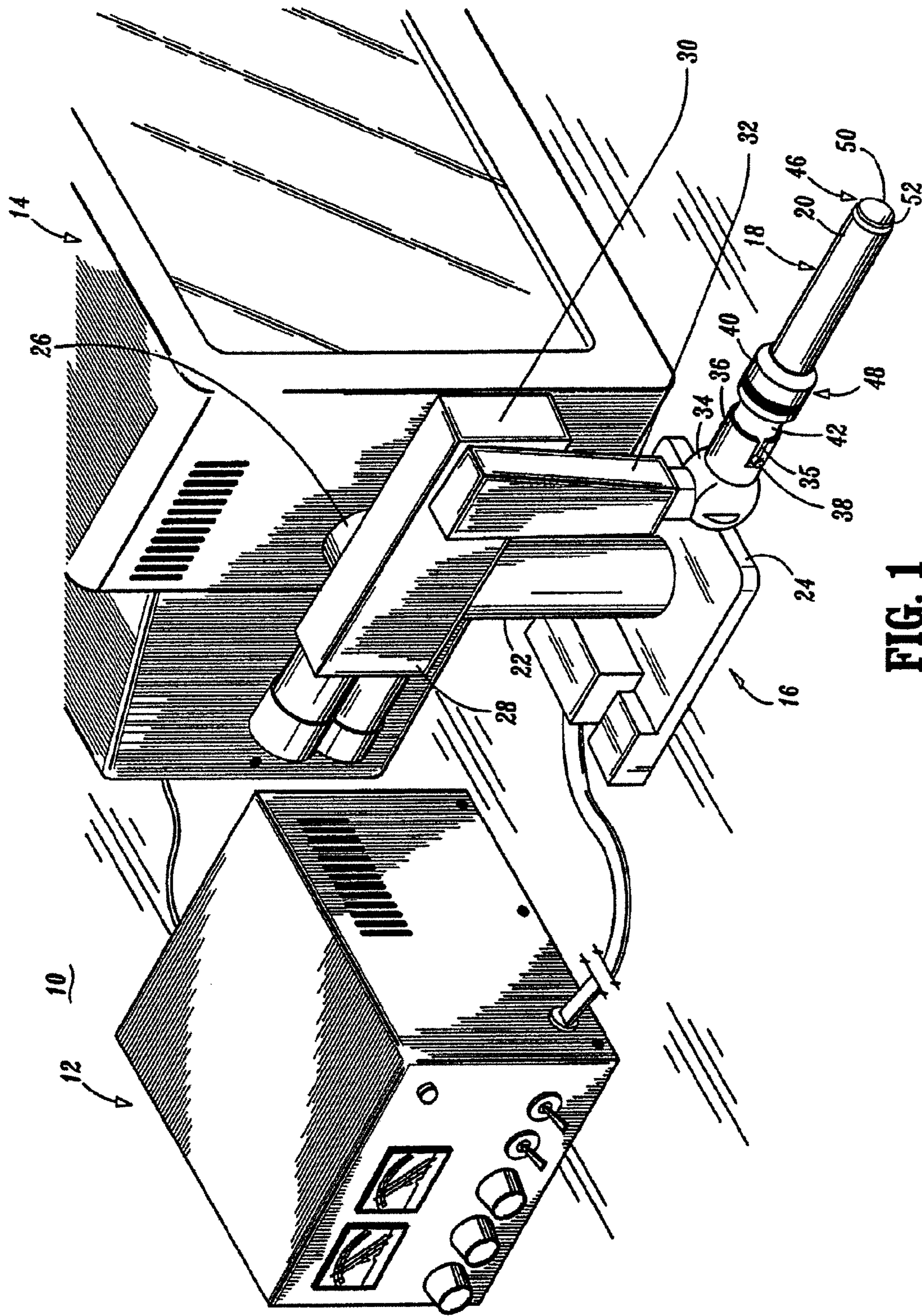

FIG. 1

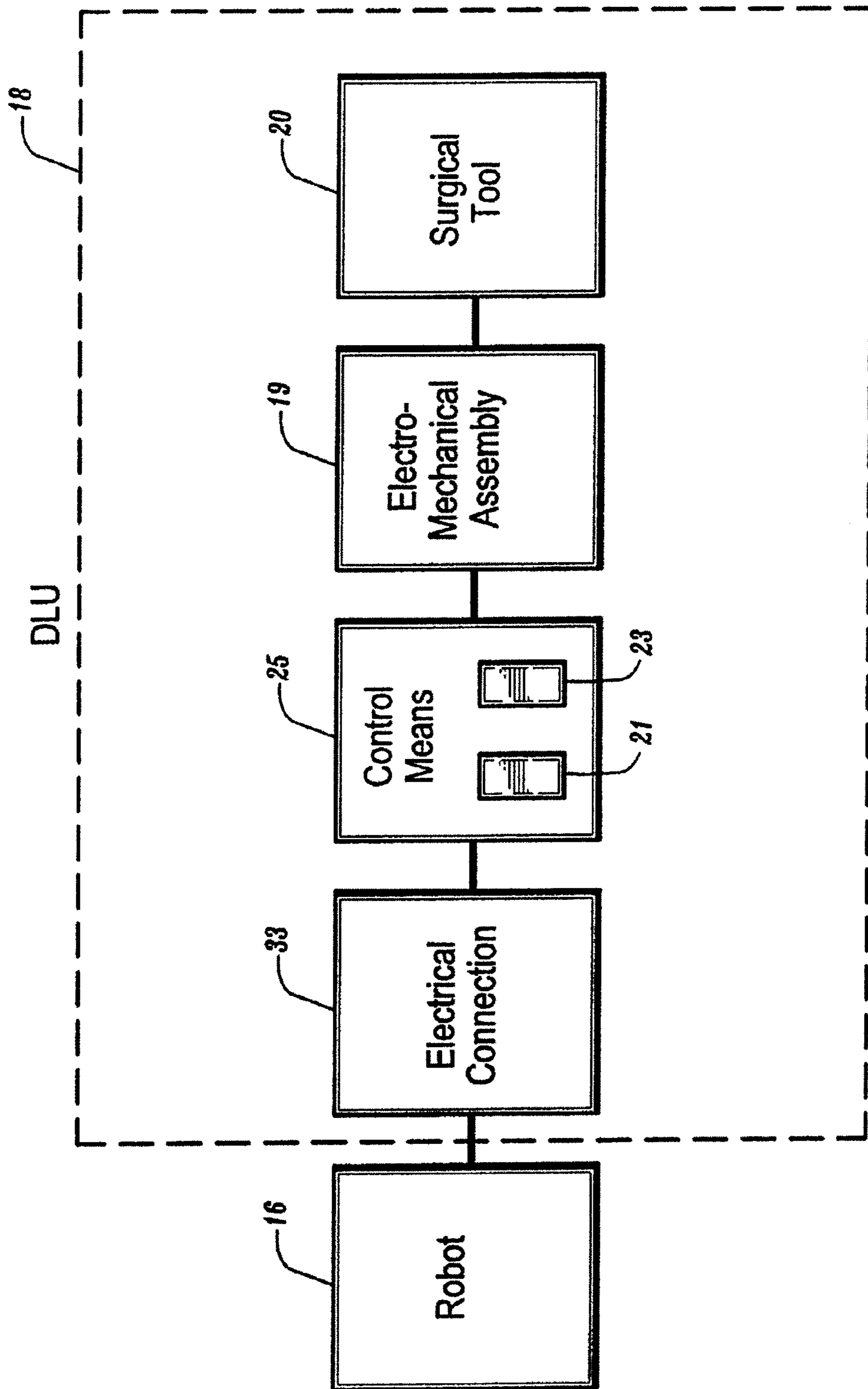
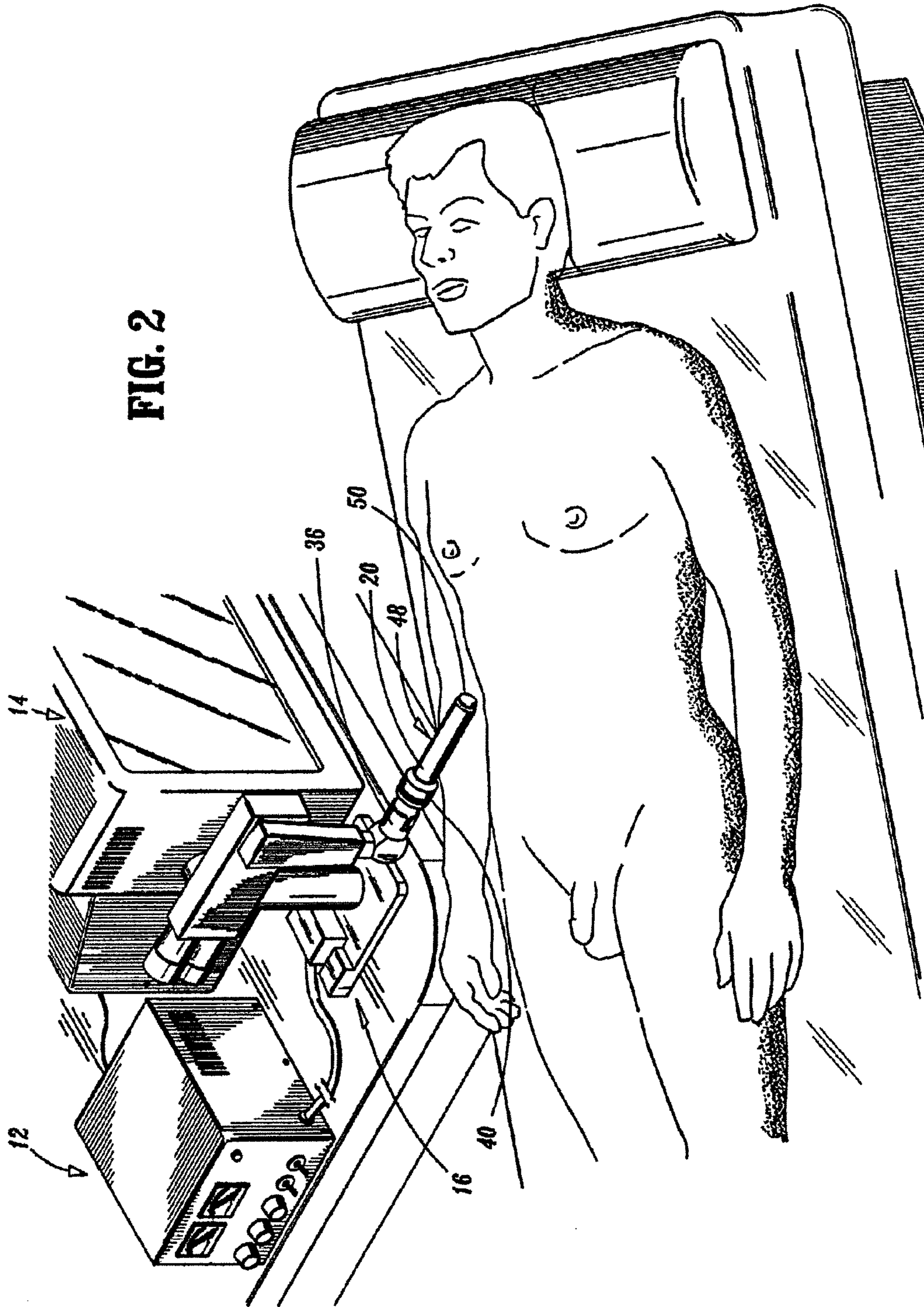

FIG. 1A



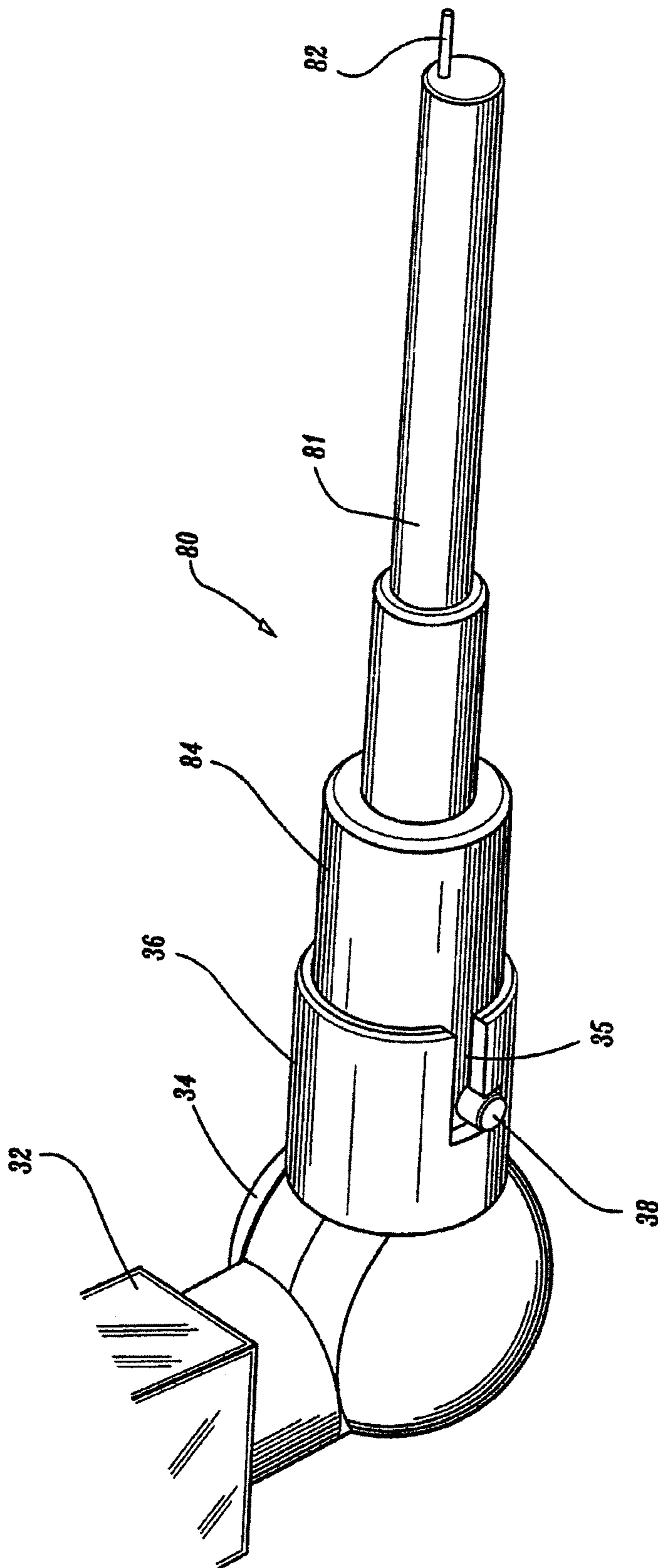

FIG. 3

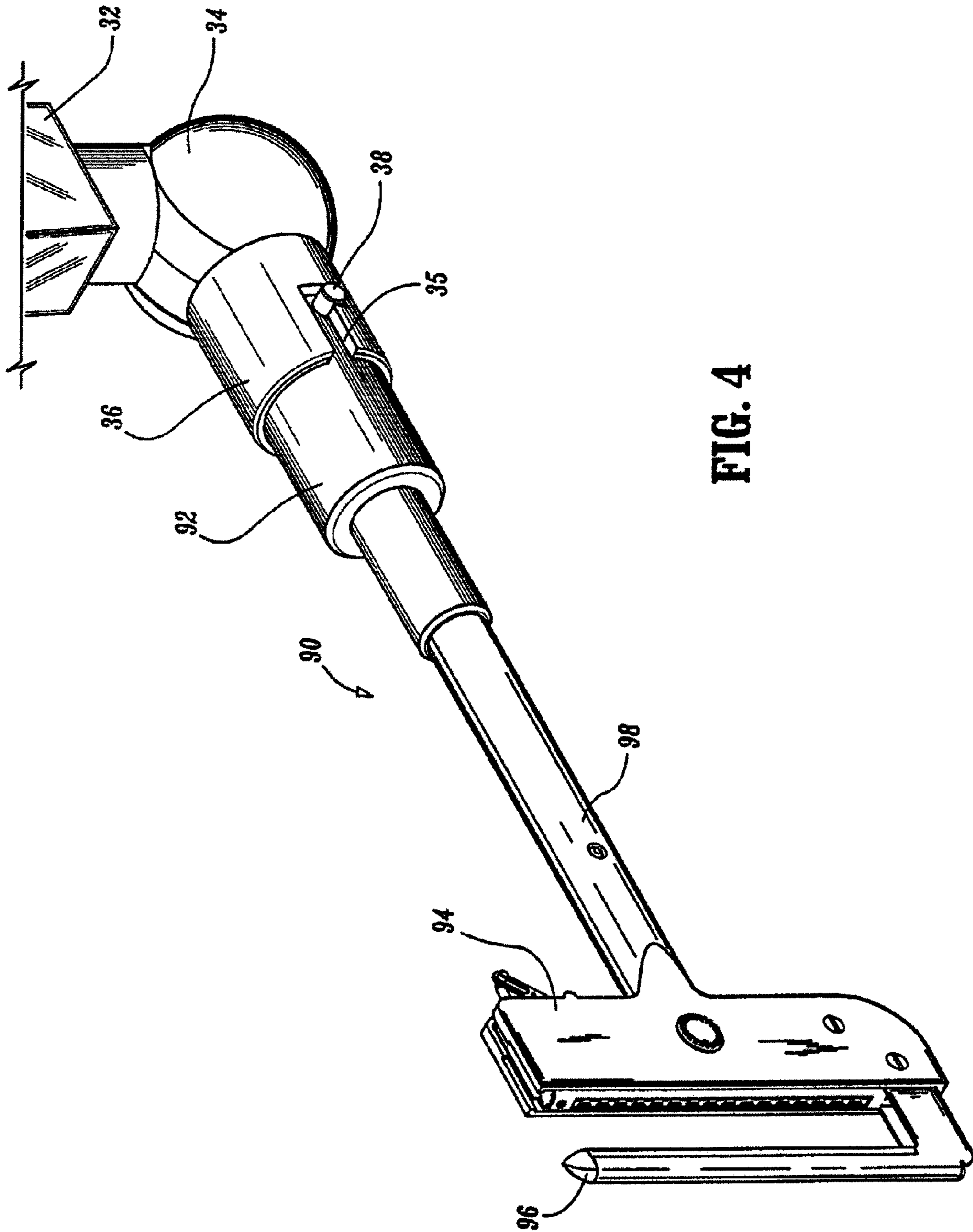
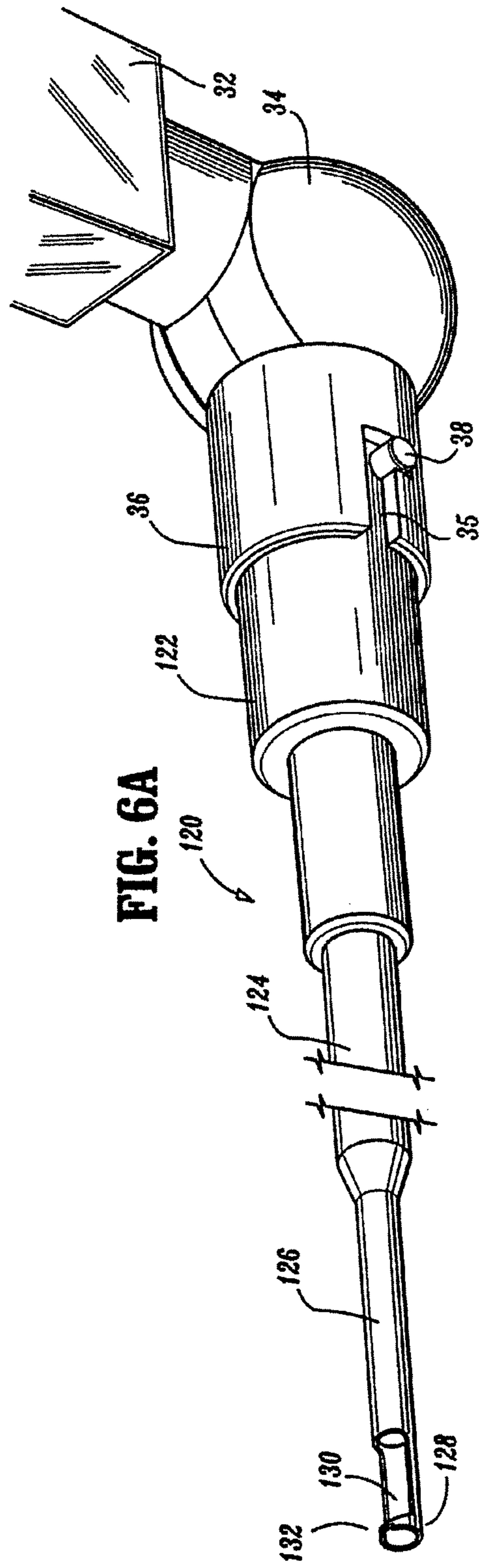
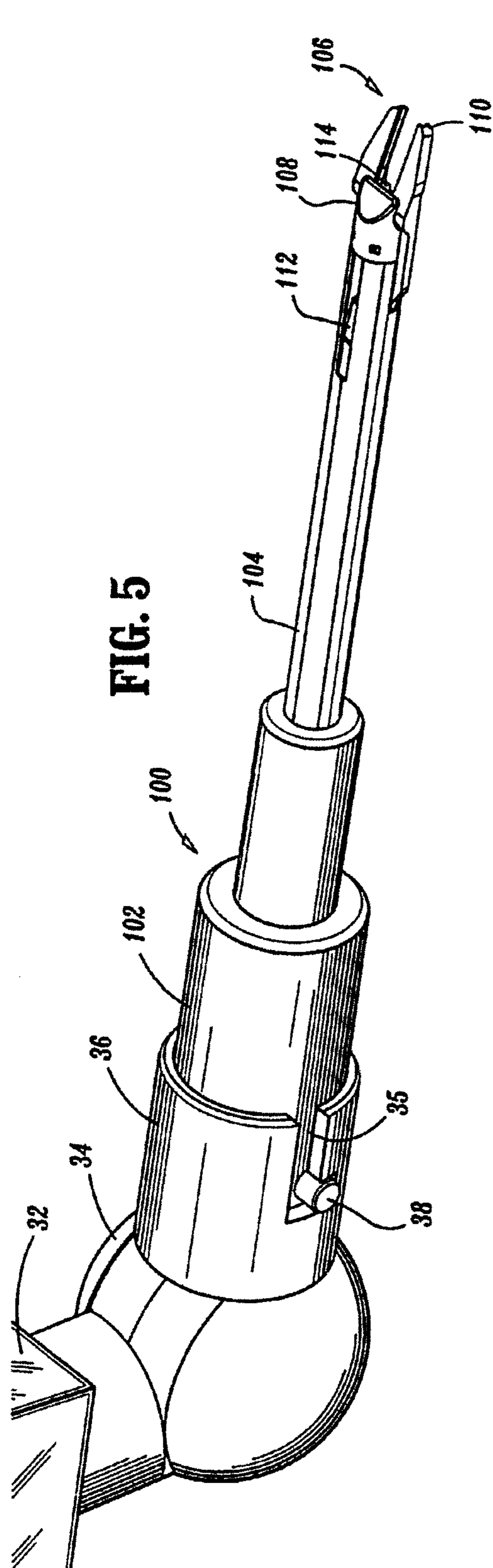
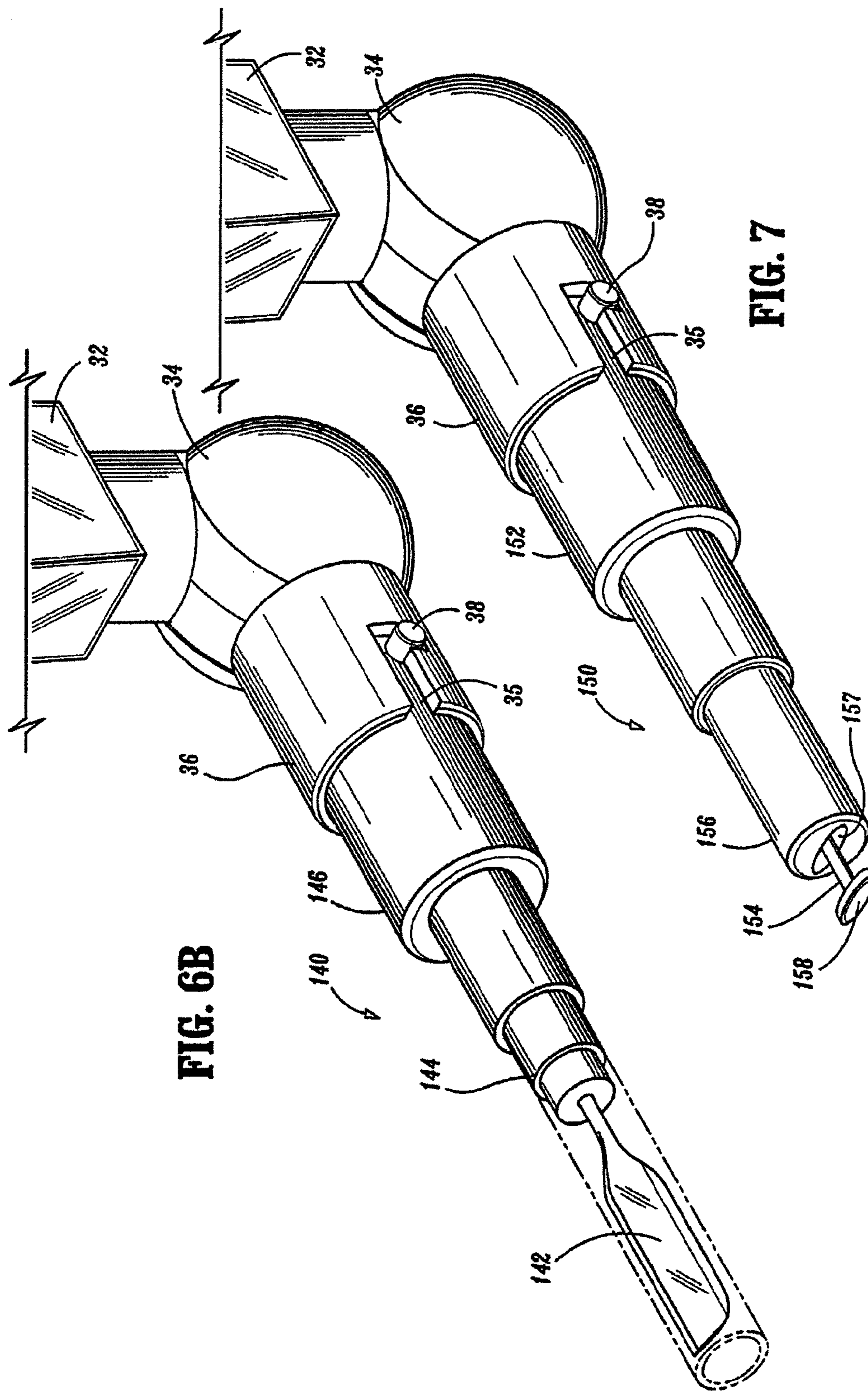

FIG. 4





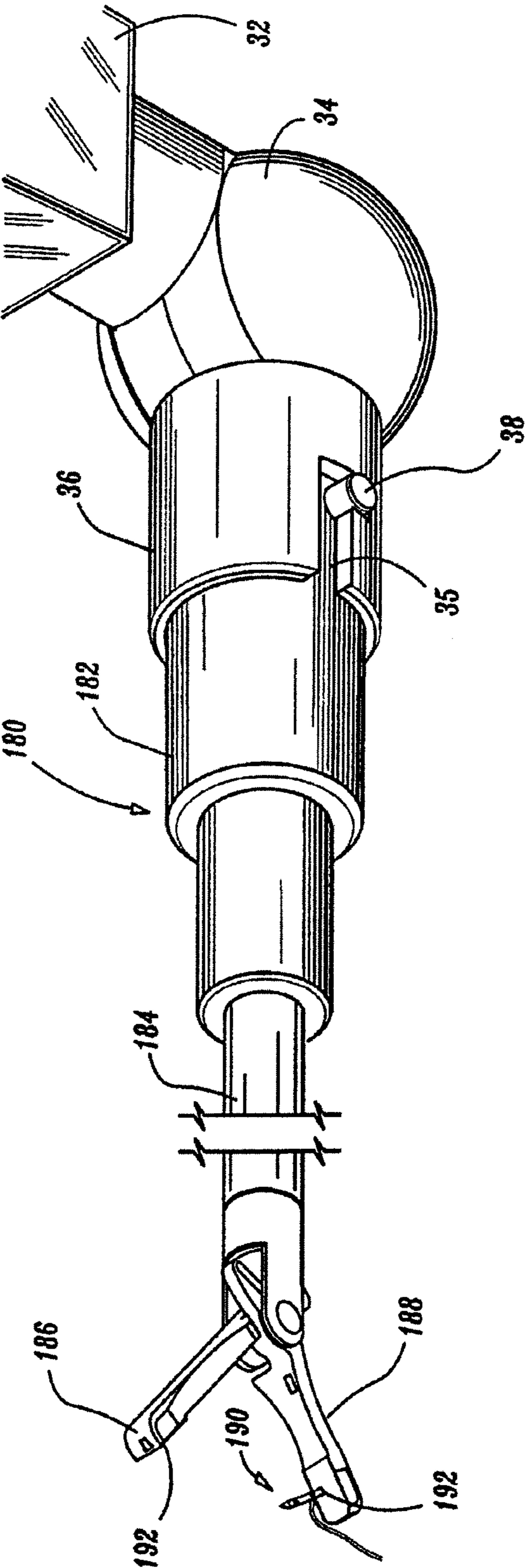

FIG. 8

ROBOTIC ARMS DLUS FOR PERFORMING SURGICAL TASKS

CROSS-REFERENCE TO RELATED APPLICATIONS

This application is a continuation of U.S. patent application Ser. No. 11/928,053, filed Oct. 30, 2007, which is a continuation of U.S. patent application Ser. No. 10/851,819, filed on May 21, 2004, now abandoned, which is a continuation of U.S. patent application Ser. No. 09/804,531, filed on Mar. 12, 2001, now U.S. Pat. No. 6,827,712, which is a divisional of U.S. patent application Ser. No. 09/099,740, filed on Jun. 18, 1998, now U.S. Pat. No. 6,231,565, which claims the benefit of, and priority to, U.S. Provisional Patent Application Ser. No. 60/049,923, filed on Jun. 18, 1997, the entire contents of each application being incorporated by reference herein in its entirety.

BACKGROUND

1. Technical Field

The present disclosure relates to an apparatus and method for performing surgical tasks. In particular, the disclosure relates to disposable loading units (DLUs) configured for mounting to a robotic arm and having at least one automatically actuated surgical tool for performing a surgical task.

2. Description of Related Art

Accurate and precise manipulation of surgical instruments at or near a surgical site is required during surgical procedures, especially during minimally invasive procedures such as laparoscopic and endoscopic procedures. In laparoscopic and endoscopic surgical procedures, a small incision is made in the patient's body to provide access for a tube or cannula device.

Once extended into the patient's body, the cannula allows insertion of various surgical instruments for acting on organs, blood vessels, ducts, or body tissue far removed from the incision site. Such instruments may include apparatus for applying surgical clips as disclosed in U.S. Pat. No. 5,084,057; apparatus for applying surgical staples as disclosed in U.S. Pat. Nos. 5,040,715 and 5,289,963; and apparatus for suturing body tissue as disclosed in U.S. Pat. No. 5,403,328.

In minimally invasive procedures, the ability to perform surgical tasks is complicated due to limited maneuverability and reduced visibility. Therefore, a need exists for an apparatus and a procedure that enables the remote actuation of surgical instruments during minimally invasive procedures in a consistent, easy and rapid manner.

In non-laparoscopic and non-endoscopic procedures, accurate and precise manipulation and operation of surgical instruments is also required. For example, in a transmural vascularization (TMR) procedure, wherein holes are formed in the heart wall to provide alternative blood flow channels for ischemic heart tissue, careful advancement and control of a lasing or coring device is necessary to form holes in the ischemic areas of the heart tissue.

In other cardiovascular procedures such as laser angioplasty wherein an optical fiber is inserted and advanced into a patient's vasculature to apply laser energy to obstructions and/or restrictions typically caused by plaque build-up, precise manipulation and operation is also required. Both continuous wave and pulsed high energy lasers have been used to provide the vaporizing laser energy. Insuring the plaque is actually ablated and not just pushed aside is important to prevent or delay restenosis.

The advent of computer imaging systems have enabled surgeons to precisely position and map the direction of travel of a surgical instrument prior to the utilization of the instrument in the operation. For example, an imaging system can locate the exact location of a lesion within a patient and allocate X, Y and Z coordinates to that lesion in space. A coring device can then be manually advanced to that location to slice the distal flat end face of the core so that a complete specimen can be removed for biopsy.

Robotic systems have also been developed to aid a surgeon in precisely mounting and positioning surgical instruments to perform a surgical task. For example, U.S. Pat. No. 5,571,110 to Matsen, III et al. discloses an orthopedic saw guide for confining the blade of a surgical saw to movement in a single plane while allowing translational and rotational movement of the blade within the plane to facilitate the performance of a surgical bone alteration task. The saw guide is positioned relative to a patient's bone by a robot-aided system.

However, known robotic systems, such as the saw guide disclosed in the Matsen et al. '110 patent, are typically limited to specific surgical tasks and are not adaptive for performing a wide variety of surgical tasks. Therefore, there is a need for a robotic system for aiding a surgeon to perform a wide variety of surgical tasks.

Another disadvantage of known robotic systems having surgical application is that the surgeon is required to manually control the position and operation of the surgical instrument. For example, systems have been developed wherein the surgeon is fitted with a mechanism which translates the surgeon's movements into mechanical movements whereby servo motors are actuated to manipulate the surgical instrument. For example, U.S. Pat. No. 5,624,398 to Smith et al. discloses a robotic system having a pair of articulate robotic arms responsive to the surgeon's movements during the surgery. However, any error in the surgeon's movements results in undesired manipulation of the robotic arms. Therefore, a fully automatic robotic system for aiding a surgeon to perform a wide variety of surgical tasks would be advantageous.

Another disadvantage with known robotic systems is their inability to remotely operate a conventional surgical tool, such as an apparatus for applying surgical staples or an apparatus for suturing body tissue which is mounted to the robotic arm.

Therefore, it would be advantageous to provide disposable loading units (DLUs) configured for mounting to a robotic arm of a robotic system and having at least one surgical tool extending from one end for performing a surgical task. The DLU would be actuated by an actuation assembly operatively associated with the robotic arm for controlling the operation and movement of the DLU. The DLU would include an electro-mechanical assembly operatively associated with the actuation assembly for controlling the operation and movement of the surgical tool.

SUMMARY

The subject disclosure is directed to disposable loading units configured for mounting to a robotic arm and having at least one automatically actuated surgical tool for performing a surgical task. The robotic arm acts on the DLUs with the dexterity and mobility of a surgeon's hand and can be programmed via an actuation assembly to actuate the surgical tool to perform the surgical task. Actuation commands are transmitted by electrical signals via cables from the actuation assembly to an electro-mechanical assembly within the DLUs. The electro-mechanical assembly within each DLU is configured to move and operate the surgical tool for perform-

ing the surgical task. For example, the electromechanical assembly may include servo motors for advancing, rotating and retracting a coring member of a coring DLU device; for harmonically oscillating a scalpel of a cutting DLU device; or for pivotally moving a suturing needle positioned on an axis of a longitudinal casing of a suturing DLU device.

One DLU presented and configured for mounting to the robotic arm is a coring DLU device for minimally invasive surgery, such as removing a specimen for biopsy. Still another DLU presented is a lasing DLU device for performing surgical procedures entailing the use of laser energy, such as TMR and angioplasty. Additional DLUs presented include a surgical fastener applying DLU device, a vessel clip applying DLU device, a cutting DLU device, a hole punching DLU device, and a vascular suturing DLU device.

BRIEF DESCRIPTION OF THE DRAWINGS

Various robotic arm DLUs for performing surgical tasks will be described hereinbelow with reference to the drawings wherein:

FIG. 1 is a perspective view of a robotic system constructed in accordance with the present disclosure and illustrating a coring DLU device;

FIG. 1A is a block diagram illustrating the components of a DLU device;

FIG. 2 illustrates a surgeon utilizing the apparatus of FIG. 1 in the performance of a surgical procedure;

FIG. 3 is a perspective view of a lasing DLU device;

FIG. 4 is a perspective view of a surgical fastener applying DLU device;

FIG. 5 is a perspective view of a vessel clip applying DLU device;

FIG. 6A is a perspective view of a first embodiment of a cutting DLU device;

FIG. 6B is a perspective view of a second embodiment of a cutting DLU device;

FIG. 7 is a perspective view of a hole-punching DLU device; and

FIG. 8 is a perspective view of a vascular suturing DLU device.

DETAILED DESCRIPTION OF EMBODIMENTS

The robotic arm disposable loading units (DLUs) and accompanying robotic system of the present disclosure shall be discussed in terms of performing a variety of surgical tasks, which include but not limited to endoscopic, arthroscopic and/or laparoscopic procedures. The present disclosure introduces and discusses several DLUs, which include a coring DLU, two cutting DLUs, an aortic hole-punching DLU, a lasing DLU, a fastener applying DLU, and a vascular suturing DLU. However, the present disclosure should not be construed to limit the present application to only these DLUs.

Referring now to the drawings wherein like reference numerals indicate similar structural elements, there is illustrated in FIG. 1 a robotic system designated generally by reference numeral 10. Robotic system 10 can be used to performing a wide variety of surgical tasks, such as operate surgical instrumentation within the abdominal cavity of a patient with a fine degree of dexterity and accuracy.

The robotic system 10 includes an actuation assembly 12, a monitor 14, a robot 16, and a DLU 18 releasably attached to the robot 16 and having at least one surgical tool 20 for performing at least one surgical task. The robot 16 includes a trunk 22 extending from a base 24, a shoulder 26 connecting the trunk to an upper arm 28, an elbow 30 connecting the

upper arm 28 to a lower arm 32, and a wrist 34 attached to the lower arm 32 from which extends a mounting flange 36. The mounting flange 36 is capable of moving in six degrees of freedom.

The DLU 18 further includes a head portion 40 for housing an electromechanical assembly 19 (FIG. 1A) therein for operating the surgical tool 20 and an attachment platform 42 for releasably attaching the DLU 18 to the robot 16 via the mounting flange 36. The mounting flange 36 includes two slots 35 which matingly engage protrusions 38 of the attachment platform 42 to connect the mounting flange 36 with the DLU 18. Other forms of releasable mechanical attachment of these components are envisioned as well, such as bayonet coupling, tongue and groove arrangements, snap-fit arrangements, interference fit arrangements, and locking screw arrangements. It is also contemplated to provide an electrical connection 33 between the slots 35 and the protrusions 38 for powering the electromechanical assembly 19 as shown by FIG. 1A.

The DLU 18 can be removed from the mounting flange 36 and be replaced with another DLU having a different surgical tool for performing a different surgical procedure. It is also contemplated to design a DLU having several surgical tools capable of performing several surgical procedures where the robot 16 can rotate the mounting flange 36 to select one of the surgical tools of the DLU when required.

In operation, the surgeon controls the actuation assembly 12 to control the movement and operation of the robot 16 and the DLU 18. Depending on the amount of rotation of the knobs 44 on the actuation assembly 12, the actuation assembly 12 transmits electrical signals to the robot 16 to electromechanically operate the moveable parts of the robot 16, such as to rotate the robot 16 about the vertical trunk 22 or to advance the mounting flange 36. The actuation assembly 12 may include a processor therein for storing operational commands and for transmitting digital signals to the electromechanical assembly 19. The actuation assembly 12 can also transmit electrical signals to the mounting flange 36 in the form of electrical signals for positioning and operating the DLU 18.

The actuation assembly 12 further transmits electrical signals to the electromechanical assembly 19 housed within the head portion 40 of the DLU 18 for actuating the electromechanical assembly 19 which in turn actuates the surgical tool 20. The electromechanical assembly 19 includes mechanisms for moving and operating the surgical tool 20, such as servo motors for harmonically oscillating a scalpel of a cutting DLU device, or rods for pivotally moving a suturing needle positioned on an axis of a longitudinal casing of a suturing DLU device. The DLU 18 may further include integrated circuitry, including a receiver 21 and a processor 23 for receiving digital signals from the actuation assembly. The receiver 21 and processor 23 are included within control means 25 electrically connected to the electromechanical assembly 19 as shown by FIG. 1A.

One type of electromechanical assembly can be used to advance, rotate and retract a coring portion 46 of a coring DLU device 48 as shown by FIG. 1. Coring DLU device 48 is suited for performing a coring procedure, such as coring body tissue for removing a specimen for biopsy, as shown by FIG. 2. The coring portion 46 includes a tubular member 50 having a cutting edge 52. The linear advancement of the tubular member 50 is automatically controlled by the electromechanical assembly 19.

When the coring DLU device 48 is actuated by transmitting electrical signals to the electromechanical assembly 19, the tubular member 50 can be distally and proximally moved by

5

rods traversing the longitudinal axis of the coring portion **46** and operatively associated with the electromechanical assembly **19**.

A lasing DLU device **80** is illustrated in FIG. **3** for performing surgical procedures requiring laser energy, such as a TMR procedure. Laser DLU device **80** includes a laser energy transmission mechanism **82** partially disposed within a body portion **81** and mounted for controlled longitudinal movement relative to a head portion **84** of the DLU **80**. The actuation assembly **12** can be provided with a laser energy generator which is optically connected to the laser energy transmission mechanism **82** for initiating laser energy. The laser energy generator may also be incorporated within the electromechanical assembly **19**. The laser energy transmission mechanism **82** typically includes at least one optical fiber for transmitting laser energy. The at least one optical fiber in the laser energy transmission mechanism **82** traverses the body portion **81** and is optically associated with the laser energy generator.

A controlled advancement mechanism is provided within the DLU head portion **84** and in engagement with the laser energy transmission mechanism **82** for advancing the laser energy transmission mechanism **82** at a controlled rate coordinated with the laser energy generator output to ablate body tissue. Controlled advancement mechanisms which can be incorporated within the head portion **84** include constant and/or variable rate springs, motors, and other mechanisms which can be coordinated with the laser energy generator to advance one or both of the laser energy transmission mechanism **82** during ablation.

A surgical fastener applying DLU device **90** is illustrated in FIG. **4** for applying an array of surgical fasteners to body tissue. Surgical fastener applying DLU device **90** includes an actuator incorporated within a head portion **92** to perform fast closure and incremental advancement of a cartridge assembly **94** with respect to an anvil assembly **96** at a distal end of body portion **98**.

Reference can be made to U.S. Pat. No. 4,508,253 issued to Green on Apr. 2, 1985 or European Patent Application No. 92 116880.3 published on Apr. 21, 1993, the contents of both documents are incorporated herein by reference, for a more detailed explanation of the operation of the body portion components during a surgical fastening procedure. It is provided that the hand portion of the fastener applying apparatus disclosed in the '006 patent is incorporated within the structure and construction of the electro-mechanical assembly **19** of the surgical fastener applying DLU device **90** for operating the body portion components in the same manner as the hand portion operates the body portion components in the above-noted '006 patent.

FIG. **5** is a perspective view of a vessel clip applying DLU device **100** for applying surgical clips to body tissue. Vessel clip applying DLU device **100** includes a head portion **102**, a body portion **104** extending distally from the head portion **102** and defining a longitudinal axis, and a plurality of surgical clips disposed within the body portion **104**. A jaw assembly **106** is mounted adjacent a distal end portion **108** of the body portion **104**. The jaw assembly **106** includes first and second jaw portions **110** movable between a spaced-apart and approximated position.

A clip pusher is provided within body portion **104** to individually distally advance a distal-most surgical clip to the jaw assembly **106** while the jaw portions **110** are in the spaced-apart position. An actuator **112** disposed within the body portion **104** is longitudinally movable in response to actuation of the electromechanical assembly **19** within the head portion **102**. A jaw closure member **114** is positioned adjacent the first

6

and second jaw portions **110** to move the jaw portions **110** to the approximated position. The actuator **112** and the jaw closure member **114** define an interlock therebetween to produce simultaneous movement of the actuator **112** and the jaw closure member **114** when the actuator **112** is positioned adjacent the distal end portion of the body portion **104**.

Reference can be made to U.S. Pat. No. 5,300,081 issued to Young et al. on Apr. 5, 1994, the contents of which are incorporated herein by reference, for a more detailed explanation of the operation of the body portion components during a vessel clip applying procedure. It is provided that the hand portion of the vessel clip applying apparatus disclosed in the '081 patent is incorporated within the structure and construction of the electro-mechanical assembly **19** of the vessel clip applying DLU device **100** for operating the body portion components in the same manner as the hand portion operates the body portion components in the above-noted '081 patent.

With reference to FIG. **6A**, a first embodiment of a cutting DLU device **120** is illustrated for cutting and storing sections of body tissue. Cutting DLU device **120** includes an actuator incorporated within a head portion **122**, a body portion **124** having an outer tube **126** extending from the head portion **122**, and a cutting tube **128** positioned within the outer tube **126** and movable in response to actuation of the electromechanical assembly **19** between a retracted position and a distal position to cut body tissue. The cutting tube **128** has a chamber **130** formed therein for storing the cut tissue sections.

A release lever is included within the electro-mechanical assembly **19** and is movable from a blocking position to allow the cutting tube **128** to be removed from the outer tube **126**. An anvil **132** is positioned at a distal end of the outer tube **126** for forcing each cut tissue section proximally into the chamber **130** of the cutting tube **128** as the cutting tube **128** is advanced to cut the body tissue. The electro-mechanical assembly may include an oscillation assembly operatively associated with the cutting tube **128** to harmonically oscillate the cutting tube **128**.

A second embodiment of a cutting DLU device **140** is shown by FIG. **6B**. This embodiment includes a scalpel **142** which can be encased within a cylinder **144** capable of being moved proximally and distally. A harmonic oscillator may be incorporated within the head portion **146** to harmonically oscillate the scalpel **142**. In addition, it is contemplated to provide mechanisms within the head portion **146** for rotating and longitudinally moving the scalpel **142**.

With reference to FIG. **7**, there is shown a hole-punching DLU device **150** for facilitating the formation of an elliptical hole in the aorta during a coronary artery bypass grafting (CABG) procedure. Hole-punching DLU device **150** includes a head portion **152** having an actuator therein for actuating an actuating rod **154** disposed in body portion **156** and mounted for longitudinal movement between an unactuated position and an actuated position, and a punch blade **158** disposed at the distal end of the actuating rod **154**.

The distal end of body portion **156** includes an elliptical opening **157** to receive punch blade **158** when the actuating rod **154** is moved to the unactuated position. The elliptical opening **157** includes a sharp circumference for cutting tissue disposed between the distal end of body portion **156** and the punch blade **158** when the actuating rod **154** is moved proximally for forming an elliptical hole in a coronary artery for the performance of the CABG procedure.

Finally, with reference to FIG. **8**, a vascular suturing DLU device **180** is illustrated for suturing vascular tissue sections together. Vascular suturing DLU device **180** includes a head portion **182** and a body portion **184** extended distally therefrom. A pair of needle receiving jaws **186**, **188** are pivotally

mounted at a distal end of the body portion **184** and are configured to repeatedly pass a surgical needle and associated length of suture material therebetween. The apparatus further includes needle holding structure **190**, mounted within the jaws **186** for reciprocal movement into and out of needle holding recesses **192** formed in the jaws **186**, **188**. During an anastomosis procedure, the vascular suturing DLU device **180** will advantageously respond to movement commands transmitted from the actuation assembly to apply fasteners to tissue.

Reference can be made to U.S. Pat. No. 5,478,344 issued to Stone et al. on Dec. 26, 1995, the contents of which are incorporated herein by reference, for a more detailed explanation of the operation of the body portion components during a vascular suturing procedure. It is provided that the hand portion of the vascular suturing apparatus disclosed in the '344 patent is incorporated within the structure and construction of the electro-mechanical assembly **19** of the vascular suturing DLU device **180** for operating the body portion components in the same manner as the hand portion operates the body portion components in the above-noted '344 patent.

It is contemplated to have feedback forces initiated by pressure and other parameters indicative of the surgical task being performed by the at least one surgical tool of the DLU transmitted back through a microprocessor to a digital-to-analog circuit board. This force feedback control system allows the robotic system to be programmed before the surgical task is performed with guidance, pressure, and other parameters which can be continuously monitored to control the operation and movement of the DLU and of the at least one surgical tool.

While the invention has been illustrated and described as embodied in an apparatus and method for performing surgical tasks, it is not intended to be limited to the details shown, since it will be understood that various omissions, modifications, substitutions and changes in the forms and details of the device illustrated and its operation can be made by those skilled in the art without departing in any way from the spirit or scope of the appended claims.

What is claimed is:

1. A robotic system for performing surgical tasks, comprising:

a robotic arm; and

a disposable loading unit configured and dimensioned for releasable connection to the robotic arm, the disposable loading unit including at least one surgical tool for performing a surgical task, and storing operational information specific to the surgical task to be performed by the at least one surgical tool, the robotic arm and the disposable loading unit each including circuitry establishing bidirectional electrical communication between the robotic arm and the disposable loading unit upon connection such that a first electrical signal is generated by the disposable loading unit including the operational information that is communicated to the robotic arm to program the robotic arm with the operational information stored in the disposable loading unit, and a second, different electrical signal is generated by the robotic arm that is communicated to the disposable loading unit to regulate operation of the surgical tool according to the operational information included in the first electrical signal.

2. The robotic system according to claim **1**, wherein the robotic arm includes a mounting member with a receiving surface, and the disposable loading unit includes an engagement surface, the receiving surface and the engagement sur-

face having corresponding configurations and dimensions to facilitate releasable connection of the disposable loading unit to the robotic arm.

3. The robotic system of claim **2**, wherein the engagement surface includes a protrusion, and the receiving surface includes a slot configured and dimensioned to receive the protrusion.

4. The robotic system of claim **2**, wherein the engagement surface and the receiving surface are configured and dimensioned for frictional engagement.

5. The robotic system of claim **2**, wherein at least one of the engagement surface and the receiving surface is threaded.

6. The robotic system of claim **1**, further including an actuation assembly operatively associated with the robotic arm, wherein connection of the disposable loading unit to the robotic arm electrically and operatively couples the actuation assembly with the disposable loading unit to facilitate control over operation and movement of the surgical tool via manipulation of the actuation assembly.

7. The robotic system of claim **1**, wherein the surgical tool is configured and dimensioned to fasten tissue.

8. The robotic system of claim **1**, wherein the surgical tool is configured and dimensioned to remove tissue.

9. The robotic system of claim **1**, wherein the surgical tool is configured and dimensioned to transmit energy.

10. The robotic system of claim **1**, wherein the surgical tool is configured and dimensioned to sever tissue.

11. The robotic system of claim **1**, wherein the surgical tool is configured and dimensioned to apply a suture to tissue.

12. A robotic system for performing surgical tasks, comprising:

a robotic arm;

a first disposable loading unit configured and dimensioned for releasable connection to the robotic arm, the first disposable loading unit including a first surgical tool configured and dimensioned to perform a surgical task, and storing first operational information specific to the surgical task to be performed by the first surgical tool, the robotic arm and the first disposable loading unit each including circuitry establishing bidirectional electrical communication between the robotic arm and the first disposable loading unit upon connection such that a first electrical signal is generated by the first disposable loading unit including the first operational information that is communicated to the robotic arm to program the robotic arm with the first operational information stored in the first disposable loading unit, and a second electrical signal different than the first electrical signal is generated by the robotic arm that is communicated to the first disposable loading unit to regulate operation of the first surgical tool according to the first operational information included in the first electrical signal; and a second disposable loading unit configured and dimensioned for releasable connection to the robotic arm, the second disposable loading unit including a second, different surgical tool configured and dimensioned to perform a surgical task, and storing second operational information specific to the surgical task to be performed by the second surgical tool, the second disposable loading unit including circuitry establishing bidirectional electrical communication between the robotic arm and the second disposable loading unit upon connection such that a third electrical signal is generated by the second disposable loading unit including the second operational information that is communicated to the robotic arm to program the robotic arm with the second operational information stored in the second disposable loading

unit, and a fourth electrical signal different than the third electrical signal is generated by the robotic arm that is communicated to the second disposable loading unit to regulate operation of the second surgical tool according to the second operational information included in the third electrical signal.

13. The robotic system of claim **12**, further including an actuation assembly operatively associated with the robotic arm, wherein connection of the first disposable loading unit or the second disposable loading unit to the robotic arm electrically and operatively couples the actuation assembly with the first disposable loading unit or the second disposable loading unit to facilitate control over operation and movement of the first surgical tool or the second surgical tool via manipulation of the actuation assembly.

14. The robotic system according to claim **12**, wherein the robotic arm includes a mounting member with a receiving surface, and the first and second disposable loading units each include an engagement surface, the configuration and dimensions of the receiving surface corresponding to those of the engagement surface to facilitate releasable connection of the first disposable loading unit and the second disposable loading unit to the robotic arm.

15. The robotic system of claim **14**, wherein each engagement surface includes a protrusion, and the receiving surface includes a slot configured and dimensioned to receive the protrusion.

16. The robotic system of claim **14**, wherein each engagement surface is configured and dimensioned for frictional engagement with the receiving surface.

17. The robotic system of claim **14**, wherein each engagement surface and/or the receiving surface is threaded.

18. A robotic system for performing surgical tasks, comprising:

a robotic arm; and

a disposable loading unit configured and dimensioned for releasable connection to the robotic arm, the disposable loading unit including at least one surgical tool for performing a surgical task, the disposable loading unit storing operational information specific to the surgical task to be performed by the at least one surgical tool, the disposable loading unit communicating the operational

information to the robotic arm upon connection of the disposable loading unit and the robotic arm such that the disposable loading unit programs the robotic arm with the operational information stored in the disposable loading unit to permit operation of the surgical tool by the robotic arm.

19. The robotic system according to claim **18**, wherein the robotic arm includes first circuitry, and the disposable loading unit includes second circuitry, the first circuitry and the second circuitry establishing bidirectional electrical communication between the robotic arm and the disposable loading unit upon connection such that a first electrical signal is generated by the disposable loading unit including the operational information, and a second, different electrical signal is generated by the robotic arm that is communicated to the disposable loading unit to regulate operation of the surgical tool according to the operational information included in the first electrical signal.

20. The robotic system according to claim **18**, wherein the robotic arm includes a mounting member with a receiving surface, and the disposable loading unit includes an engagement surface, the receiving surface and the engagement surface having corresponding configurations and dimensions to facilitate releasable connection of the disposable loading unit to the robotic arm.

21. The robotic system of claim **20**, wherein the engagement surface includes a protrusion, and the receiving surface includes a slot configured and dimensioned to receive the protrusion.

22. The robotic system of claim **20**, wherein the engagement surface and the receiving surface are configured and dimensioned for frictional engagement.

23. The robotic system of claim **20**, wherein at least one of the engagement surface and the receiving surface is threaded.

24. The robotic system of claim **18**, further including an actuation assembly operatively associated with the robotic arm, wherein connection of the disposable loading unit to the robotic arm electrically and operatively couples the actuation assembly with the disposable loading unit to facilitate control over operation and movement of the surgical tool via manipulation of the actuation assembly.

* * * * *