



US008511579B2

(12) **United States Patent**
Hepner et al.

(10) **Patent No.:** **US 8,511,579 B2**
(45) **Date of Patent:** **Aug. 20, 2013**

(54) **ELEVATED RAIL SYSTEM AND REACTION ASSEMBLY**

(76) Inventors: **Alan Hepner**, Rexford, MT (US); **David Metivier**, Holladay, UT (US)

(*) Notice: Subject to any disclaimer, the term of this patent is extended or adjusted under 35 U.S.C. 154(b) by 0 days.

(21) Appl. No.: **13/373,709**

(22) Filed: **Nov. 28, 2011**

(65) **Prior Publication Data**

US 2012/0137921 A1 Jun. 7, 2012

Related U.S. Application Data

(63) Continuation of application No. 12/075,619, filed on Mar. 12, 2008, now Pat. No. 8,066,200.

(51) **Int. Cl.**
E01B 21/00 (2006.01)

(52) **U.S. Cl.**
USPC **238/2**; 104/124

(58) **Field of Classification Search**
USPC 104/118, 119, 124, 125, 126; 105/141, 105/144, 29.1; 238/2, 123
See application file for complete search history.

(56) **References Cited**

U.S. PATENT DOCUMENTS

3,583,327	A *	6/1971	Arndt	104/120
3,858,518	A *	1/1975	Nyman	104/124
3,890,904	A *	6/1975	Edwards	104/121
4,489,659	A *	12/1984	Kamohara et al.	104/124
4,909,011	A *	3/1990	Freeman et al.	52/648.1
5,575,215	A *	11/1996	Egli et al.	104/99
5,590,603	A *	1/1997	Lund	104/88.04
5,813,349	A *	9/1998	Jensen	104/28
5,845,583	A *	12/1998	Jensen	105/72.2

5,934,198	A *	8/1999	Fraser	105/144
5,964,159	A *	10/1999	Hein	104/128
5,967,265	A *	10/1999	Bruno et al.	187/201
6,047,645	A *	4/2000	Cornwell et al.	104/124
6,053,286	A *	4/2000	Balmer	187/201
6,113,401	A *	9/2000	Nieminen et al.	439/121
6,178,891	B1 *	1/2001	Ostholt et al.	104/93
6,277,473	B1 *	8/2001	McGinn	428/188
6,321,657	B1 *	11/2001	Owen	104/119
6,490,979	B1 *	12/2002	Pfleger et al.	104/172.3
6,666,147	B1 *	12/2003	Minges	104/128
6,739,430	B2 *	5/2004	Hill	187/245
6,938,391	B1 *	9/2005	Patel	52/846
7,063,763	B2 *	6/2006	Chapman, Jr.	156/175
7,066,094	B2 *	6/2006	Moutsokapas et al.	104/124
7,127,999	B2 *	10/2006	Roane	105/72.2
7,334,524	B2 *	2/2008	Roane	104/2
2001/0045326	A1 *	11/2001	Gottlieb et al.	187/254
2003/0097982	A1 *	5/2003	Ehrenleitner et al.	118/423
2004/0011242	A1 *	1/2004	Roane	105/72.2
2004/0149158	A1 *	8/2004	Keller et al.	104/89
2004/0168605	A1 *	9/2004	Minges	104/178
2005/0091825	A1 *	5/2005	Fuks et al.	29/463
2006/0178221	A1 *	8/2006	Threlkel	472/1
2007/0151193	A1 *	7/2007	Stonecypher	52/638
2008/0121133	A1 *	5/2008	Sousa Jaques	104/173.2
2009/0084863	A1 *	4/2009	Sorenson	238/122
2009/0230205	A1 *	9/2009	Hepner et al.	238/2
2009/0288578	A1 *	11/2009	Hepner et al.	105/141
2012/0137921	A1 *	6/2012	Hepner et al.	104/124

* cited by examiner

Primary Examiner — Jason C Smith

(74) *Attorney, Agent, or Firm* — Paul C. Oestreich; Eminent IP, P.C.

(57) **ABSTRACT**

The invention is an elevated rail system and reaction assembly. Features of the elevated rail system include pivot points between the track and vertical supports elevating the rail system, eccentric bolt and washer assemblies that allow precise vertical and horizontal adjustment of the vertical supports and threaded bolts that allow precise micro-adjustment of height of the track above the concrete foundations.

19 Claims, 22 Drawing Sheets

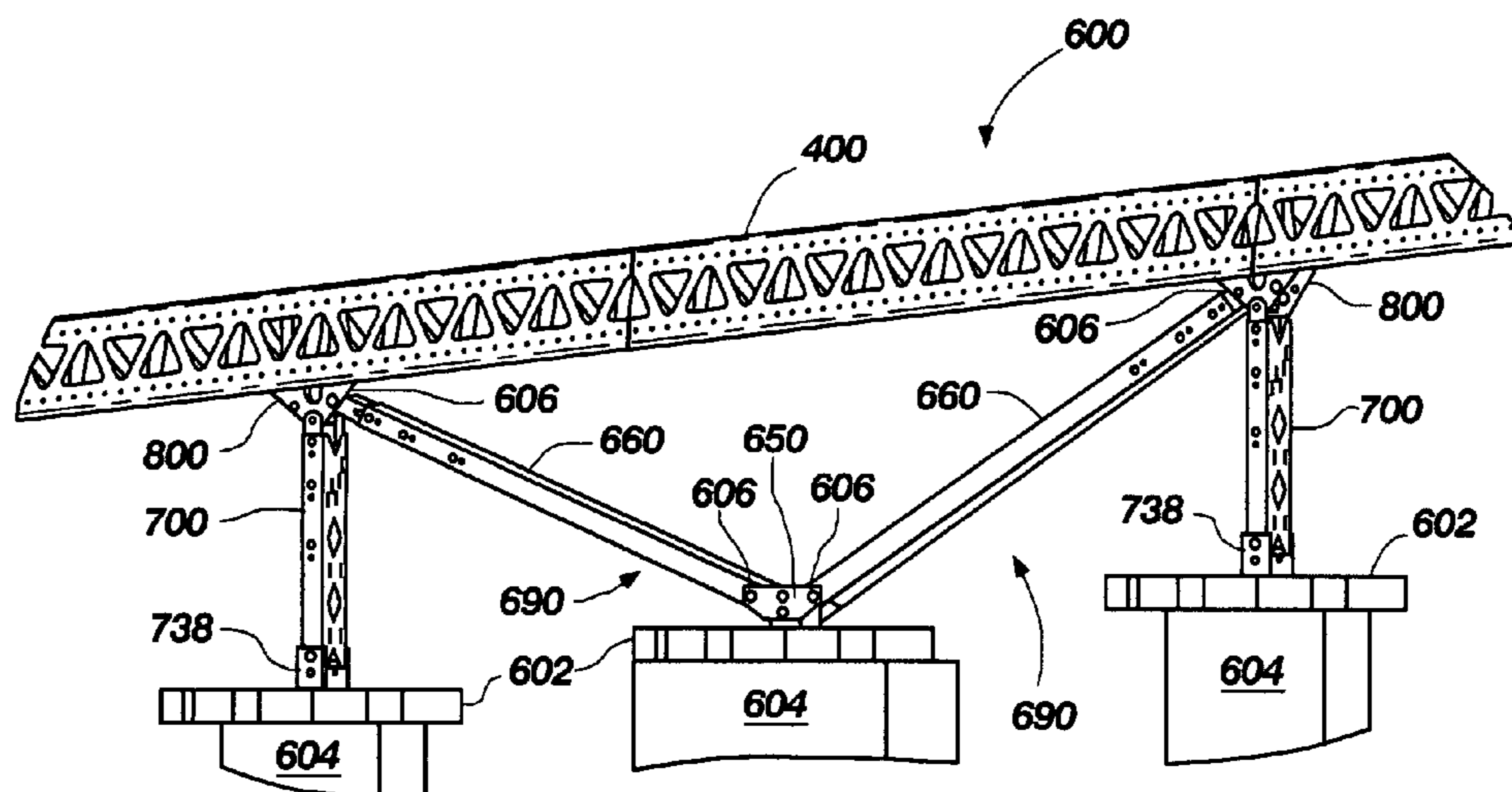

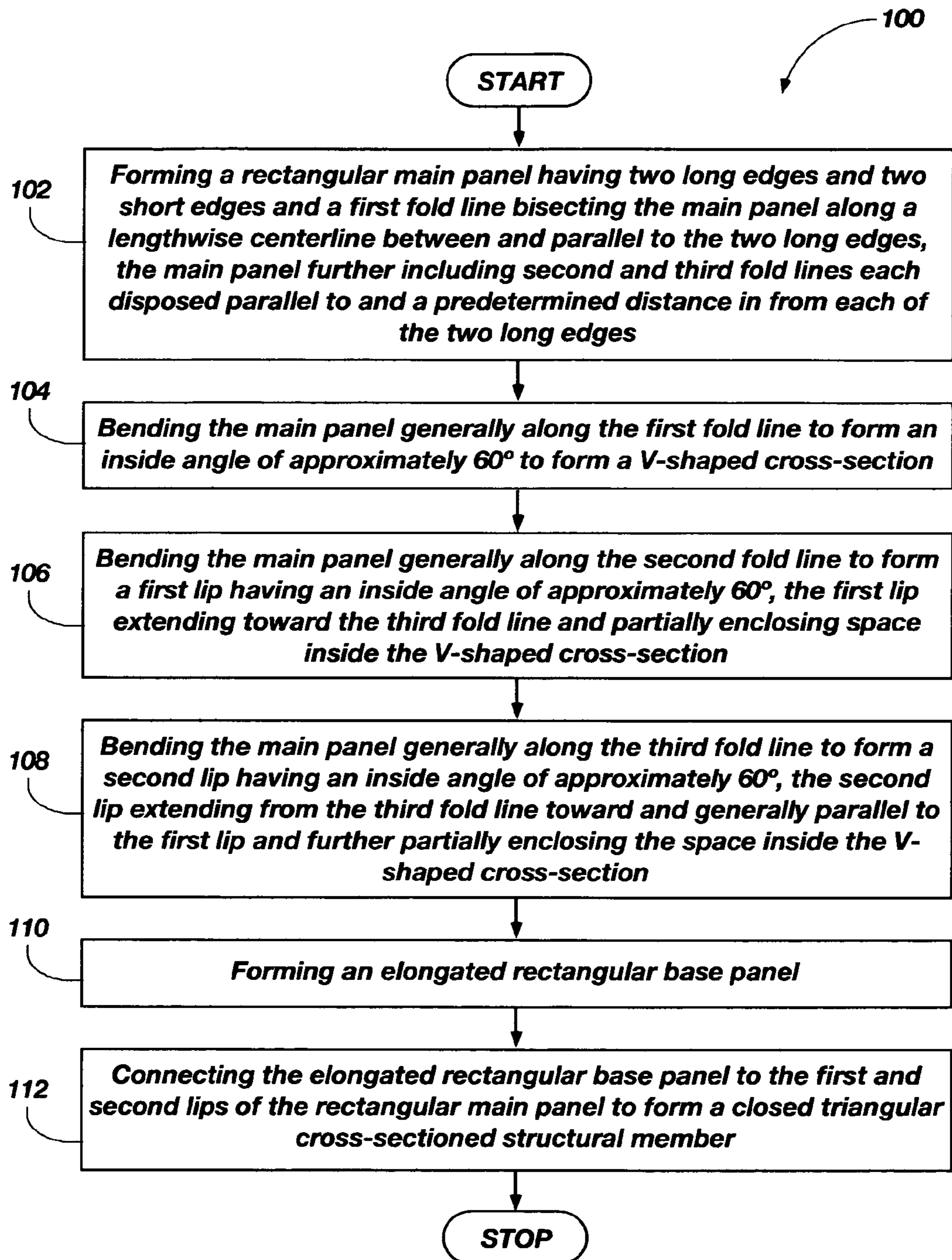
**FIG. 1**

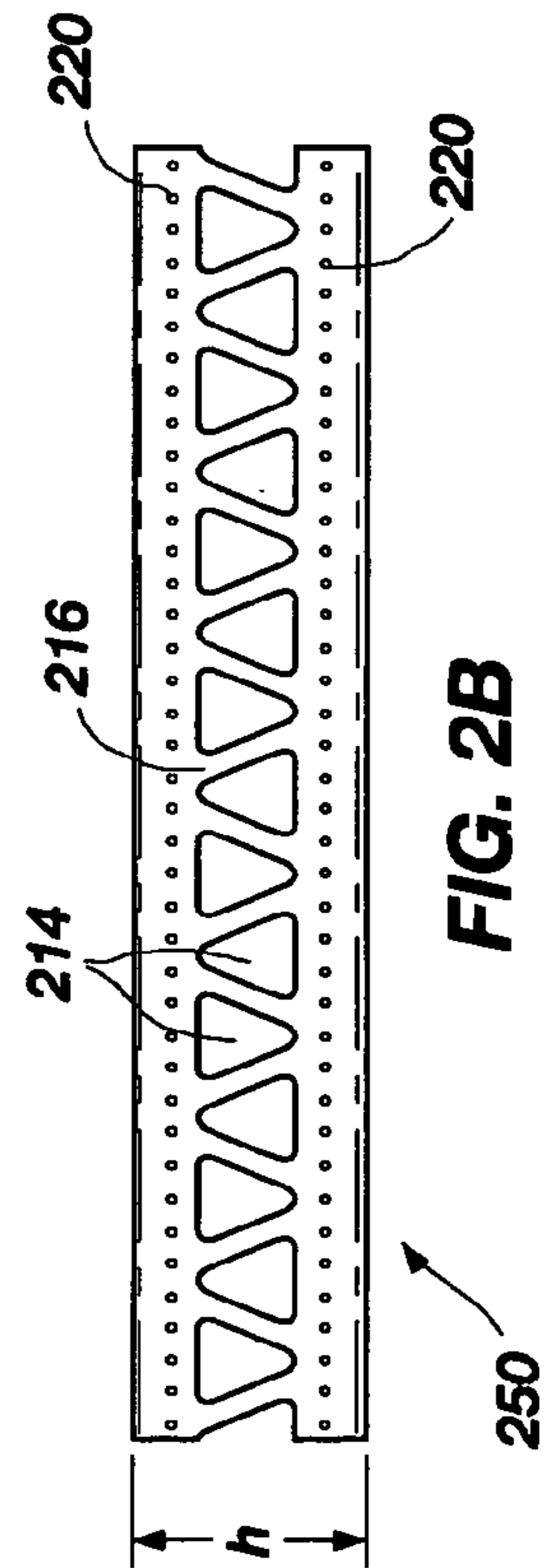
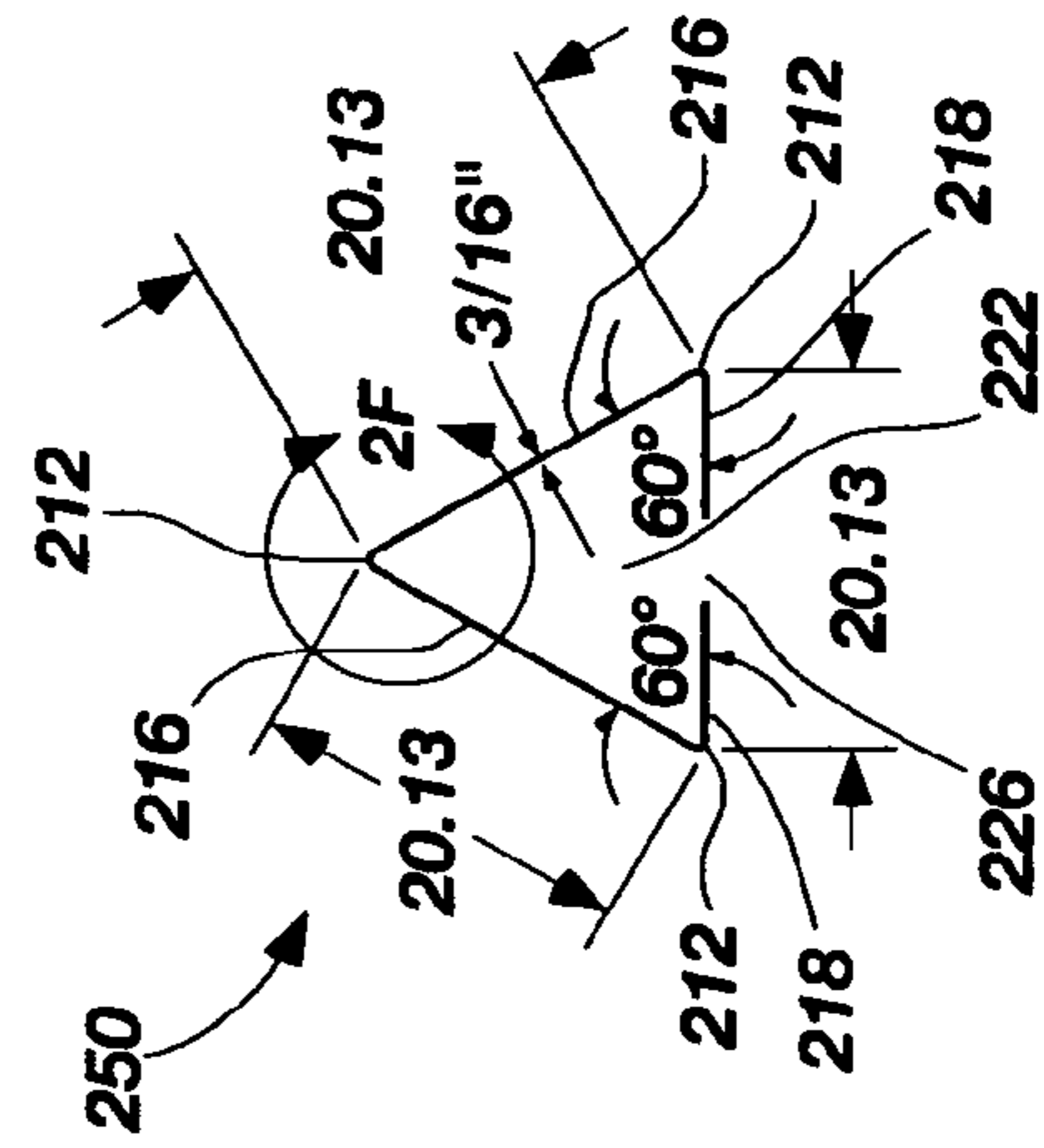
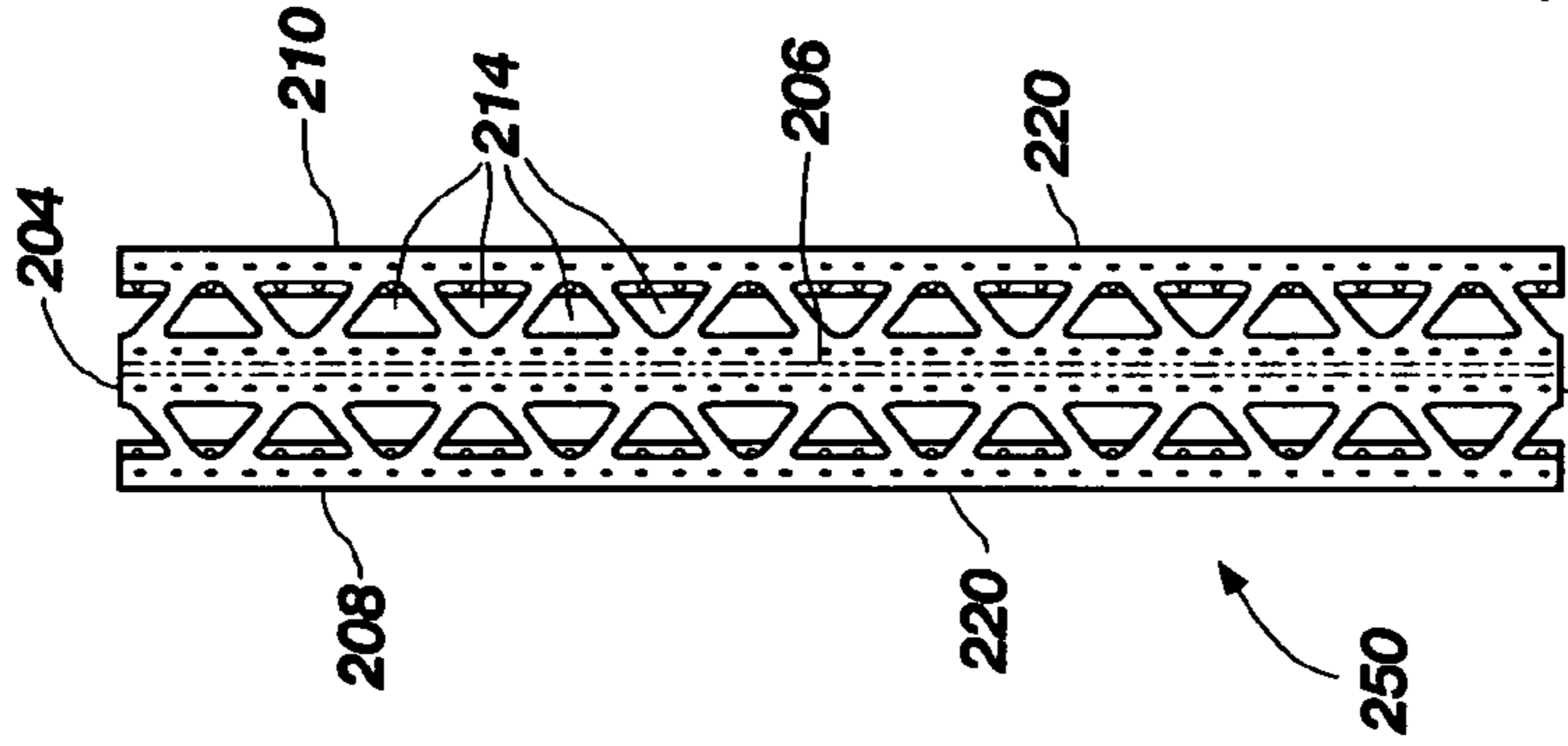
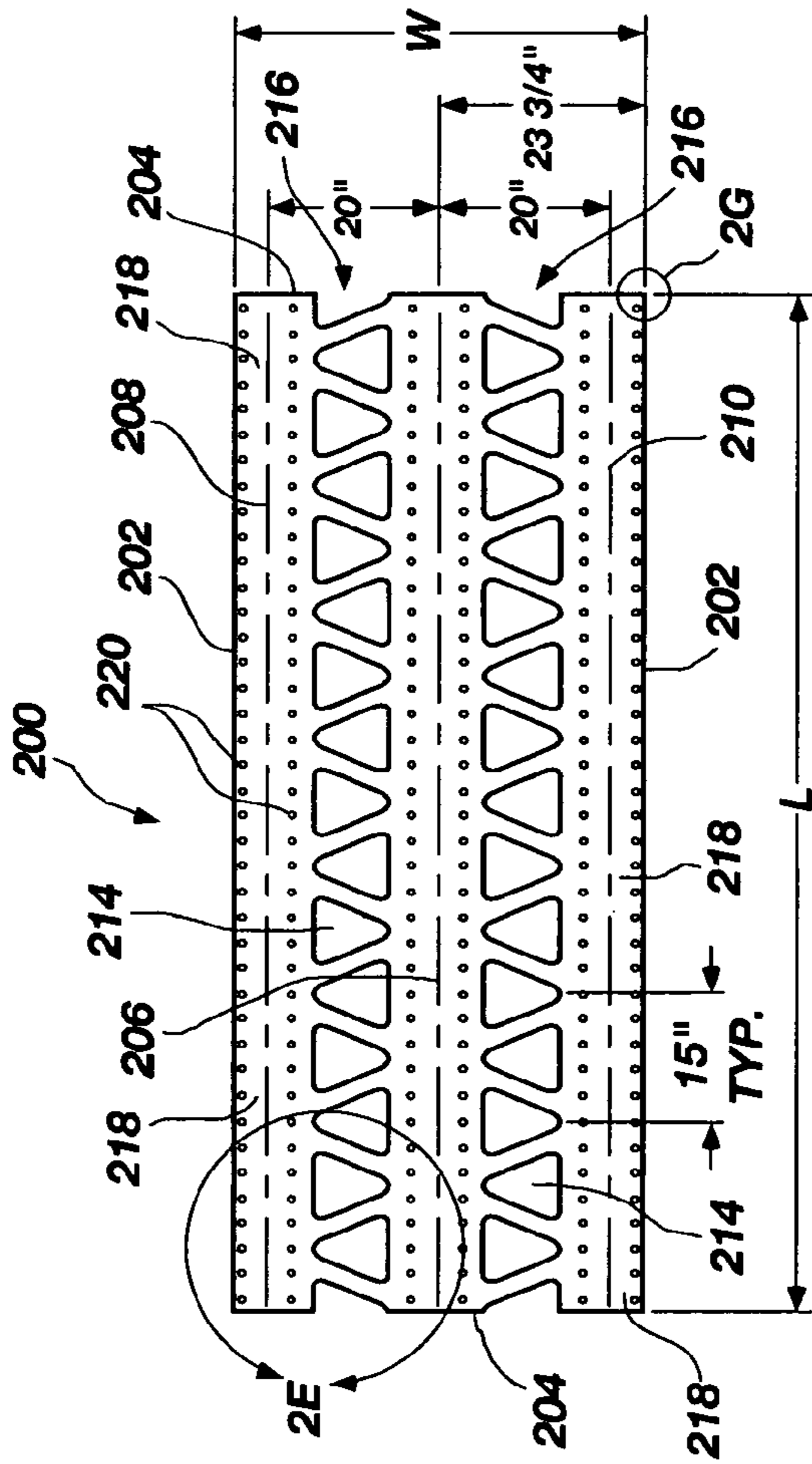

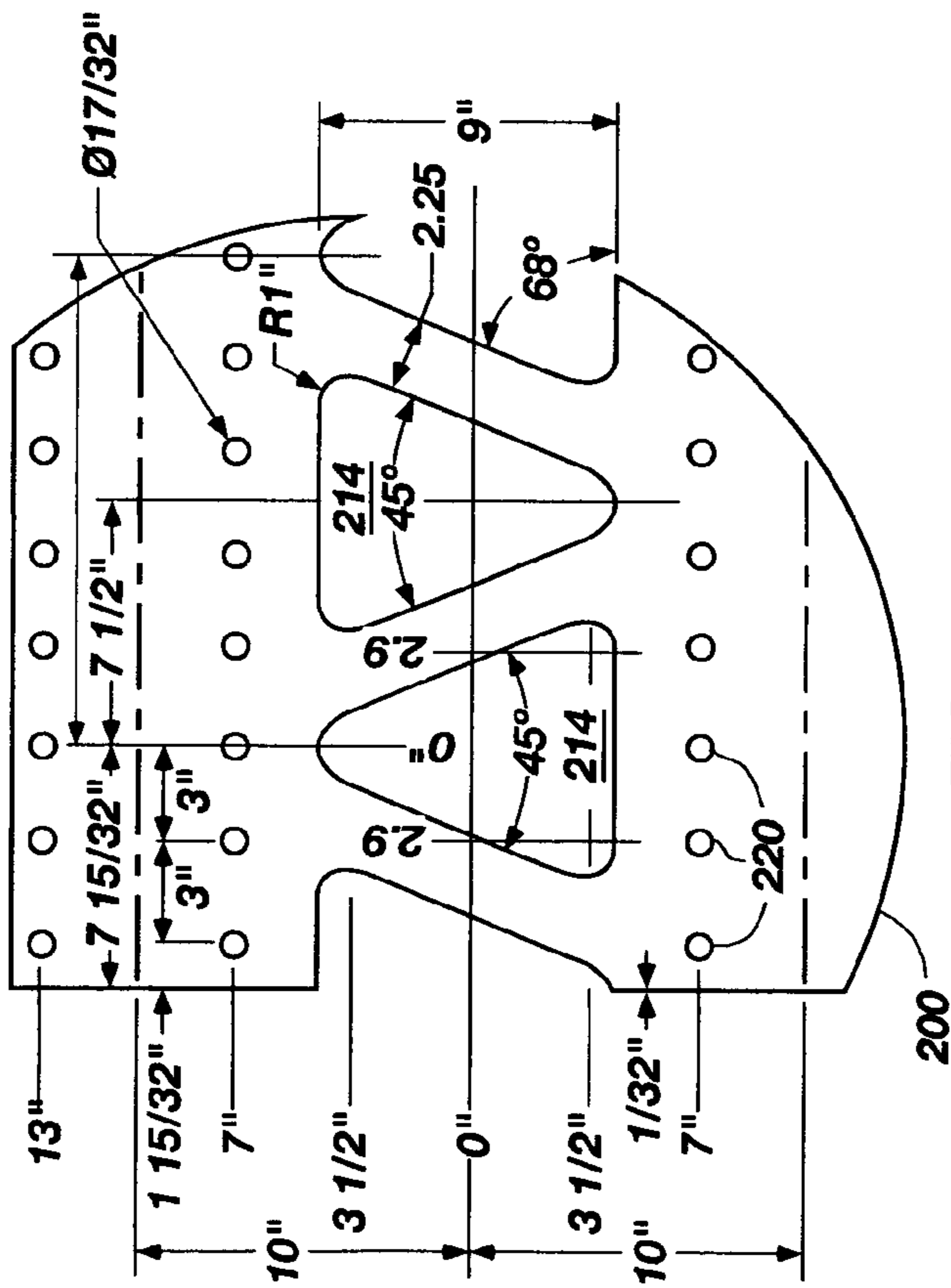

FIG. 2E

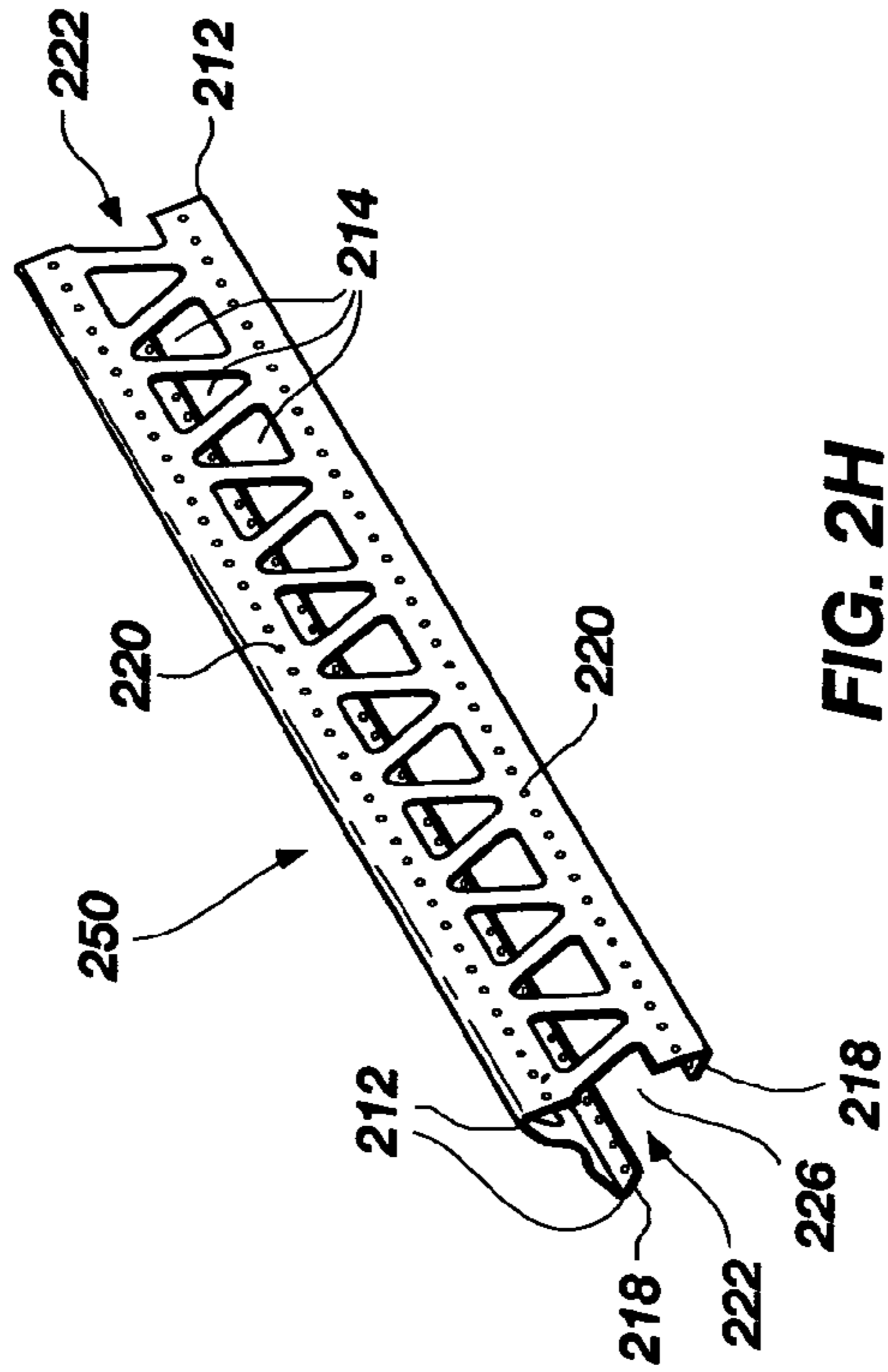

FIG. 2H

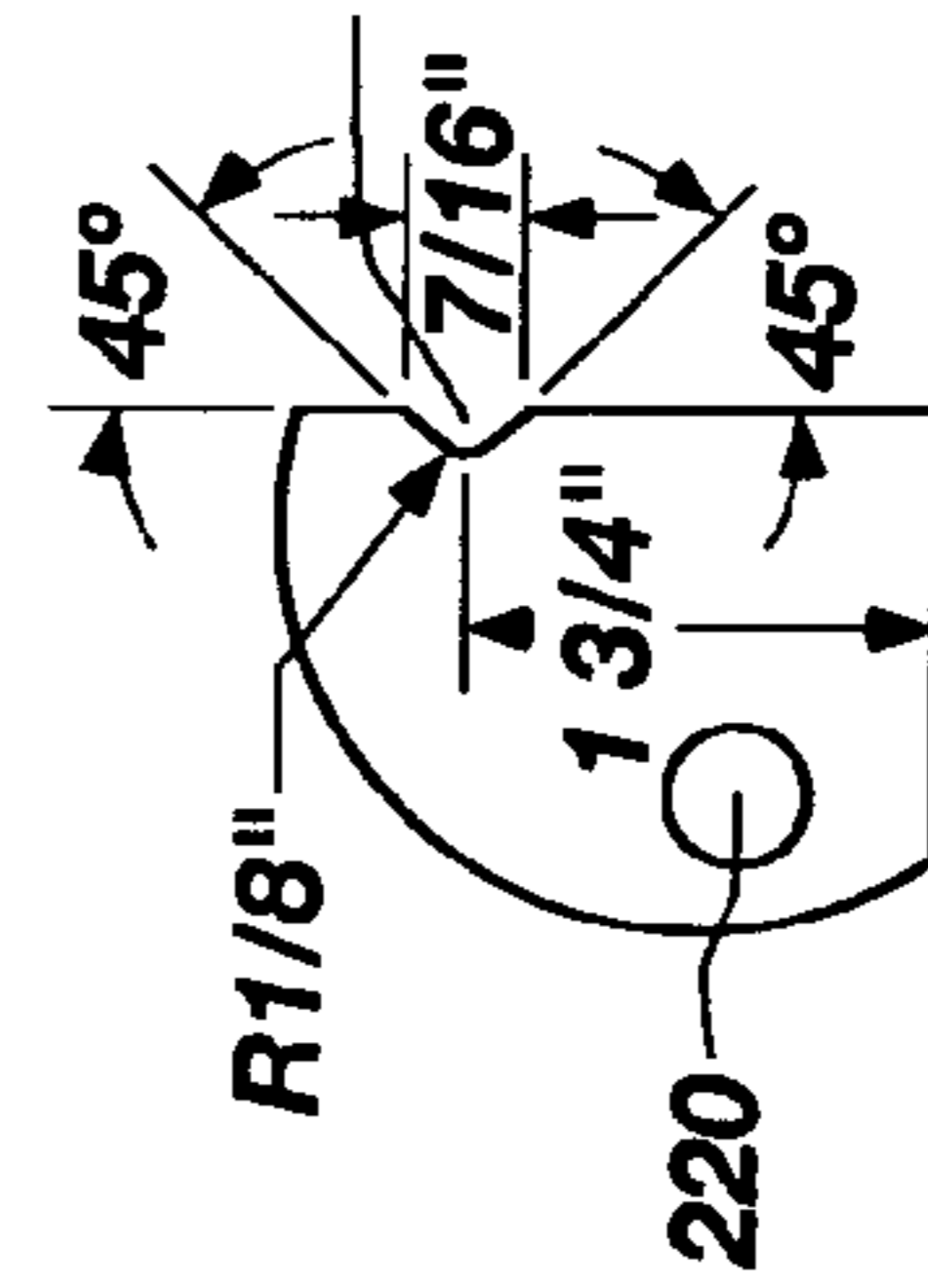

FIG. 2G

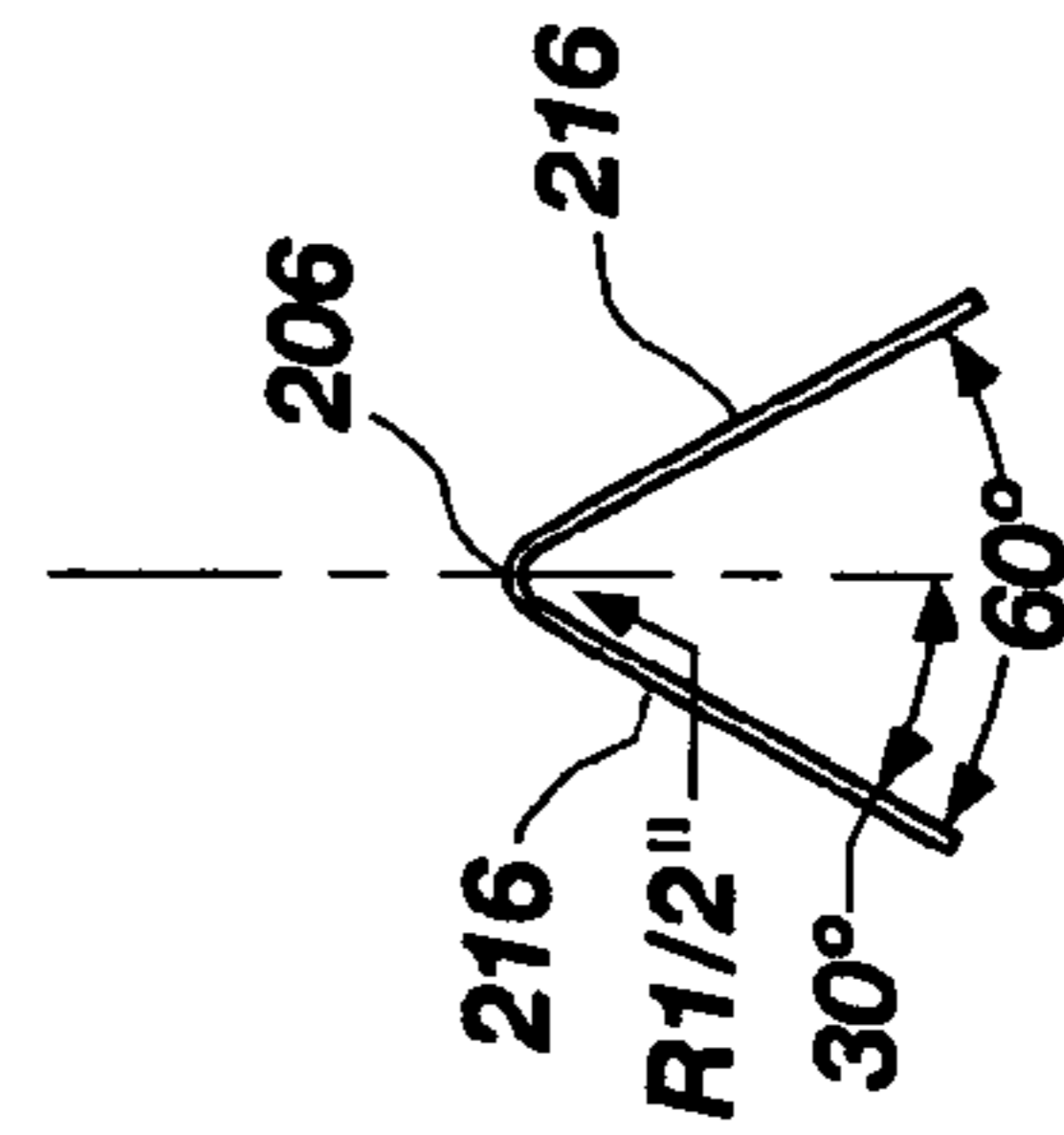

FIG. 2F

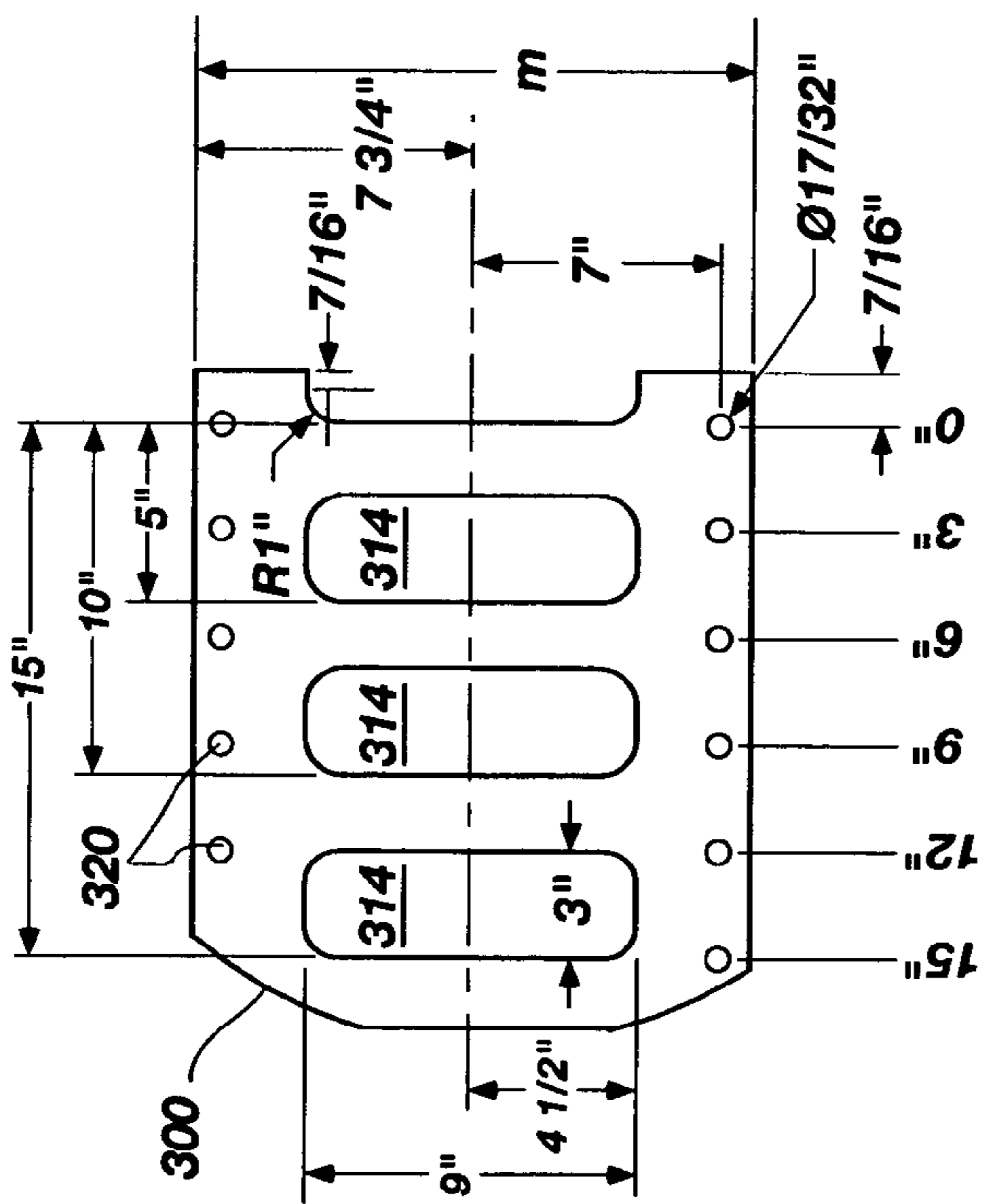

FIG. 3B

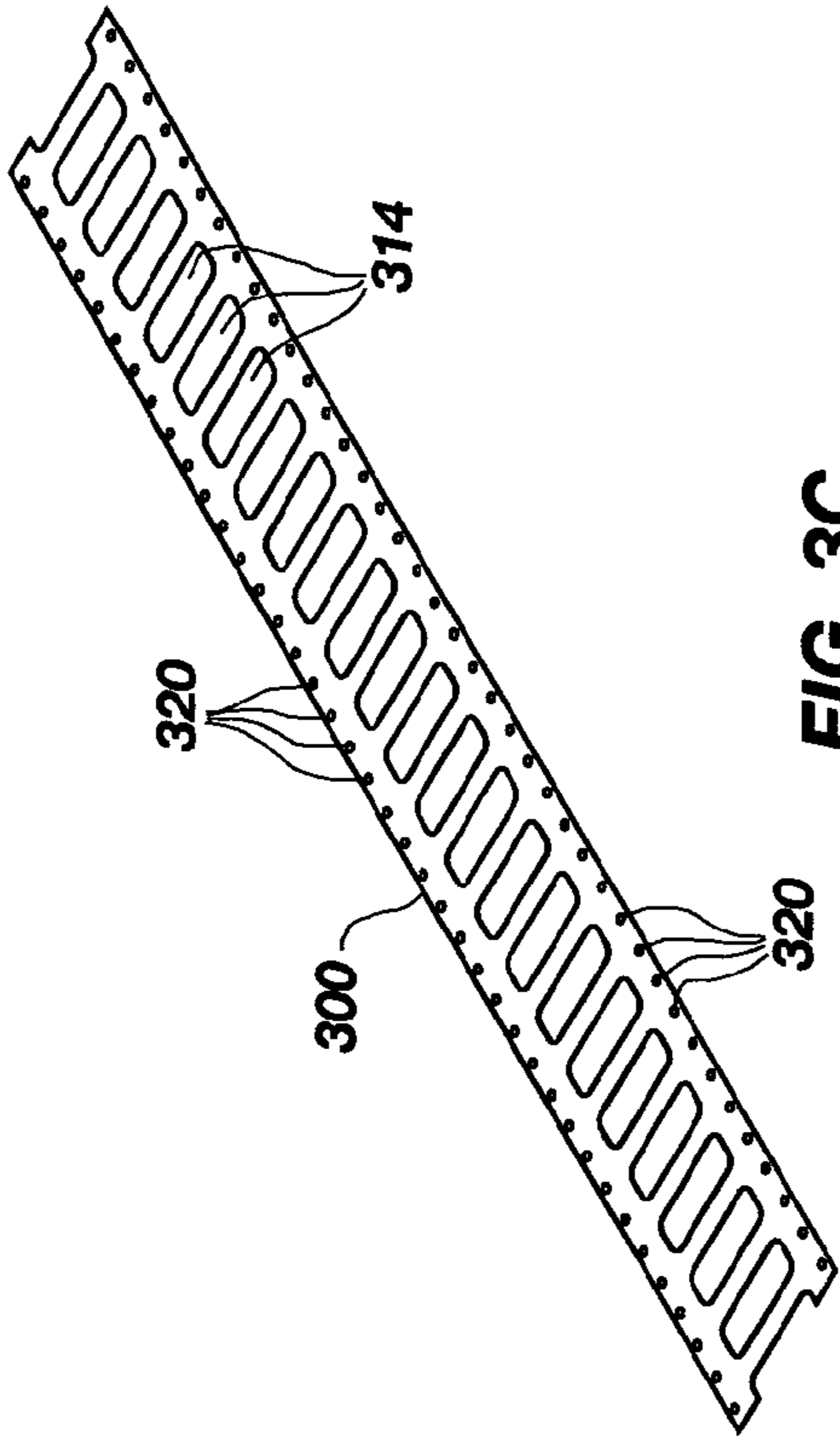

FIG. 3C

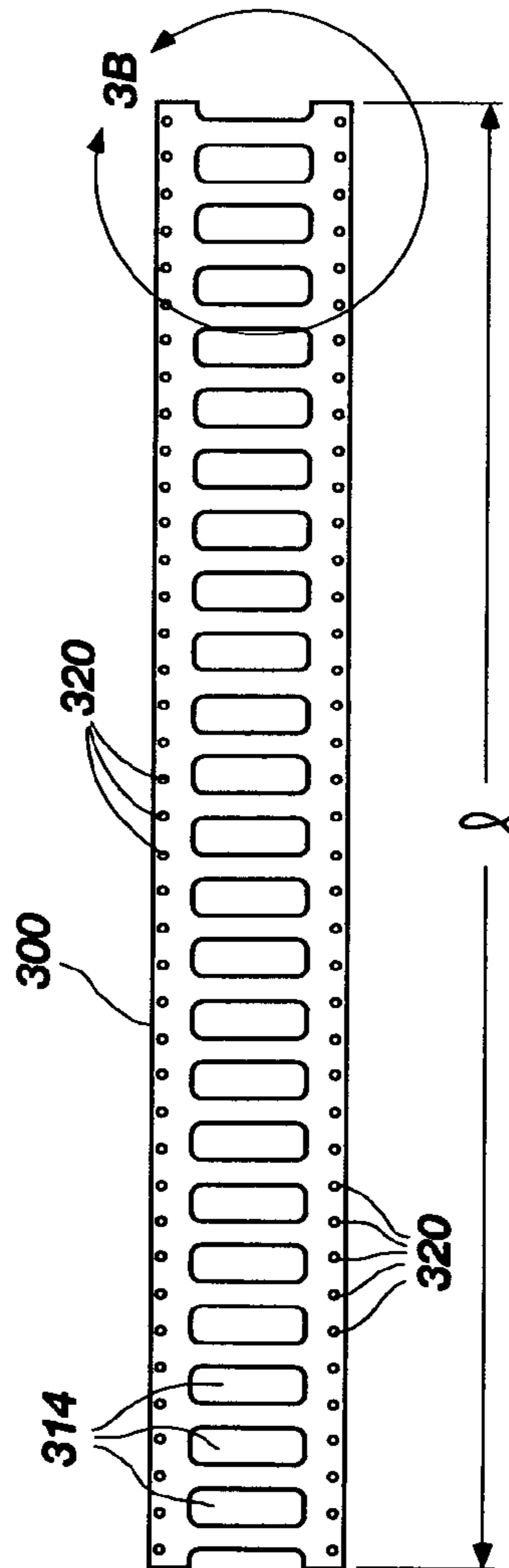
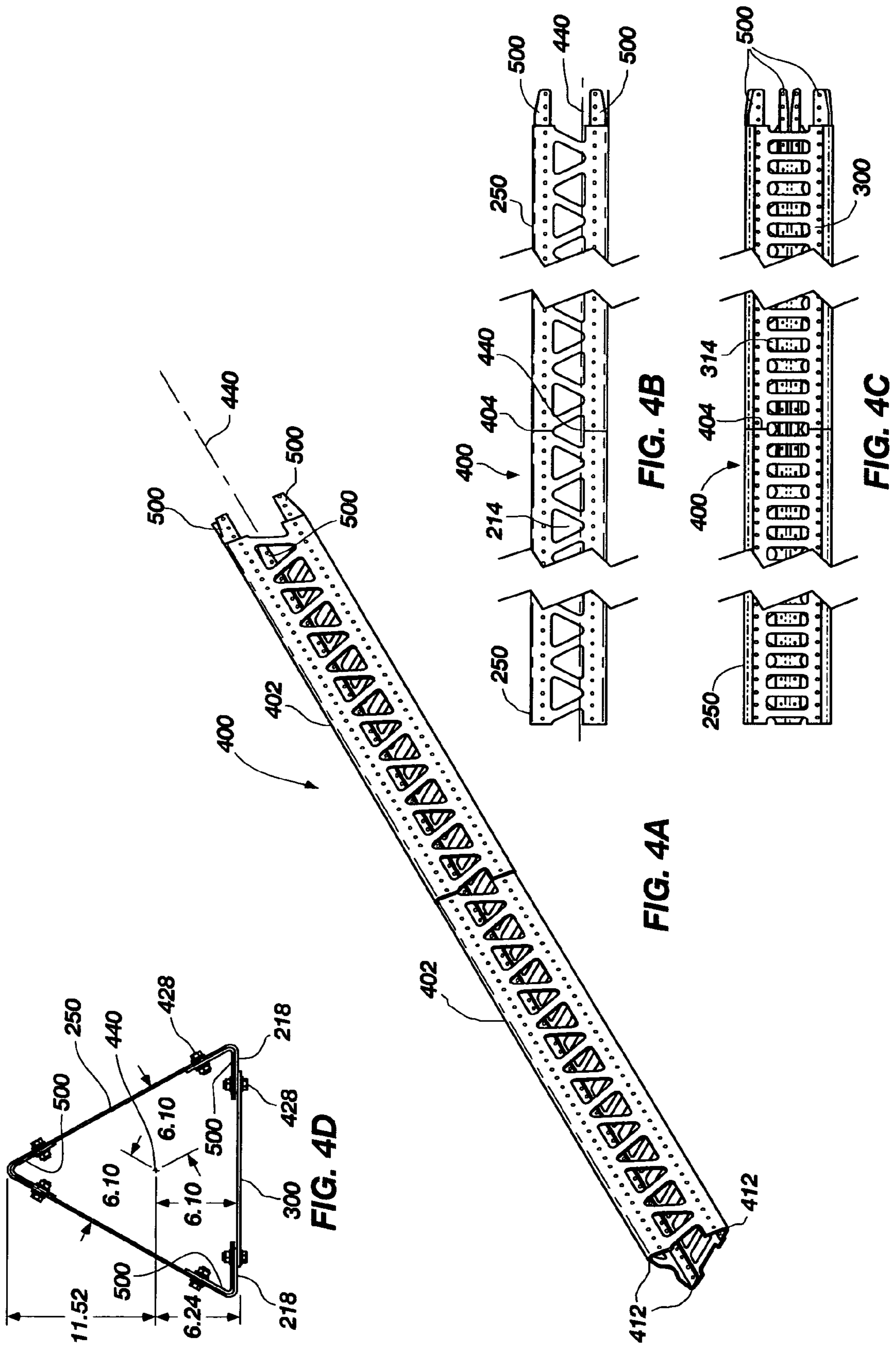

FIG. 3A



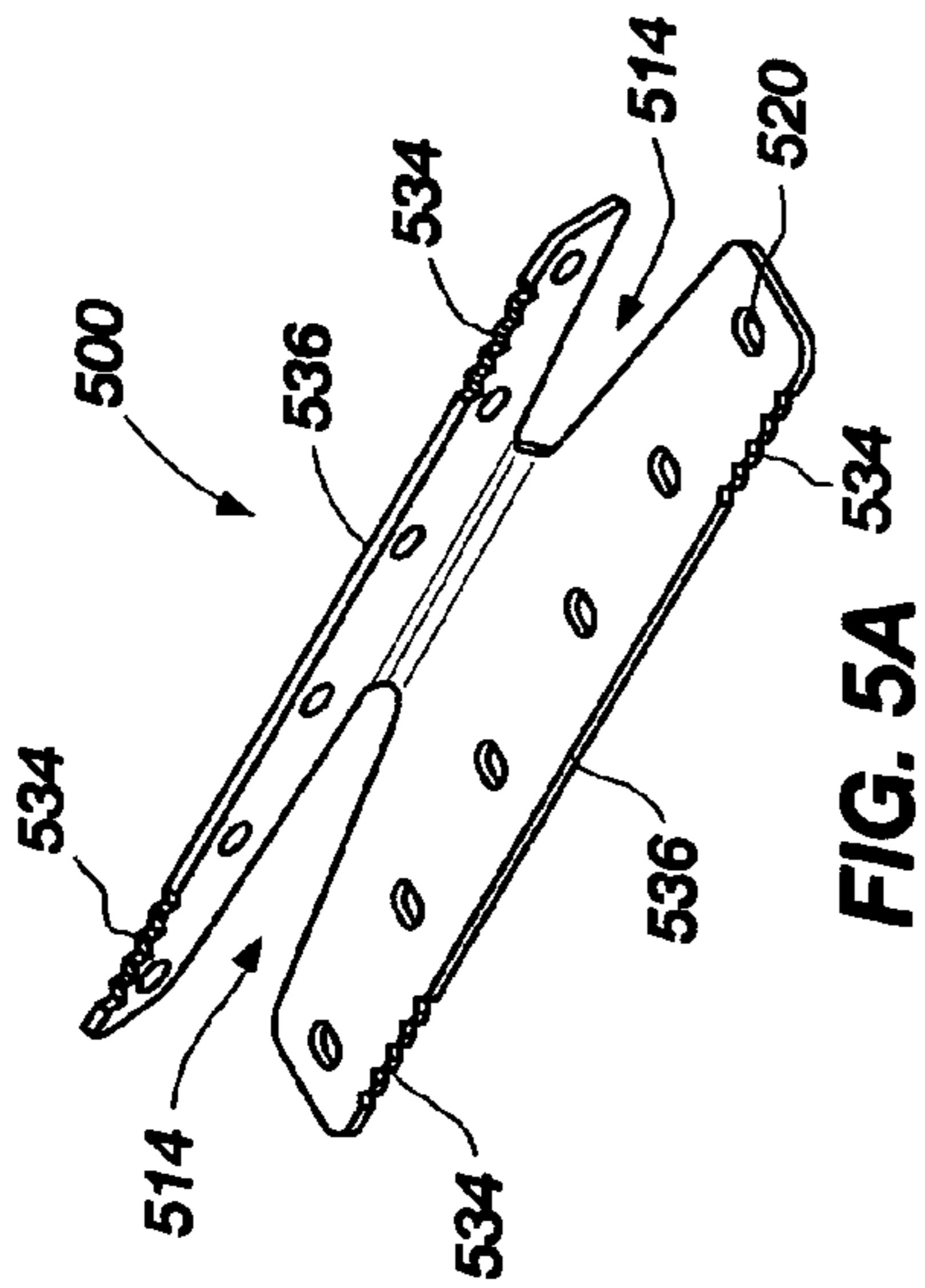

FIG. 5A

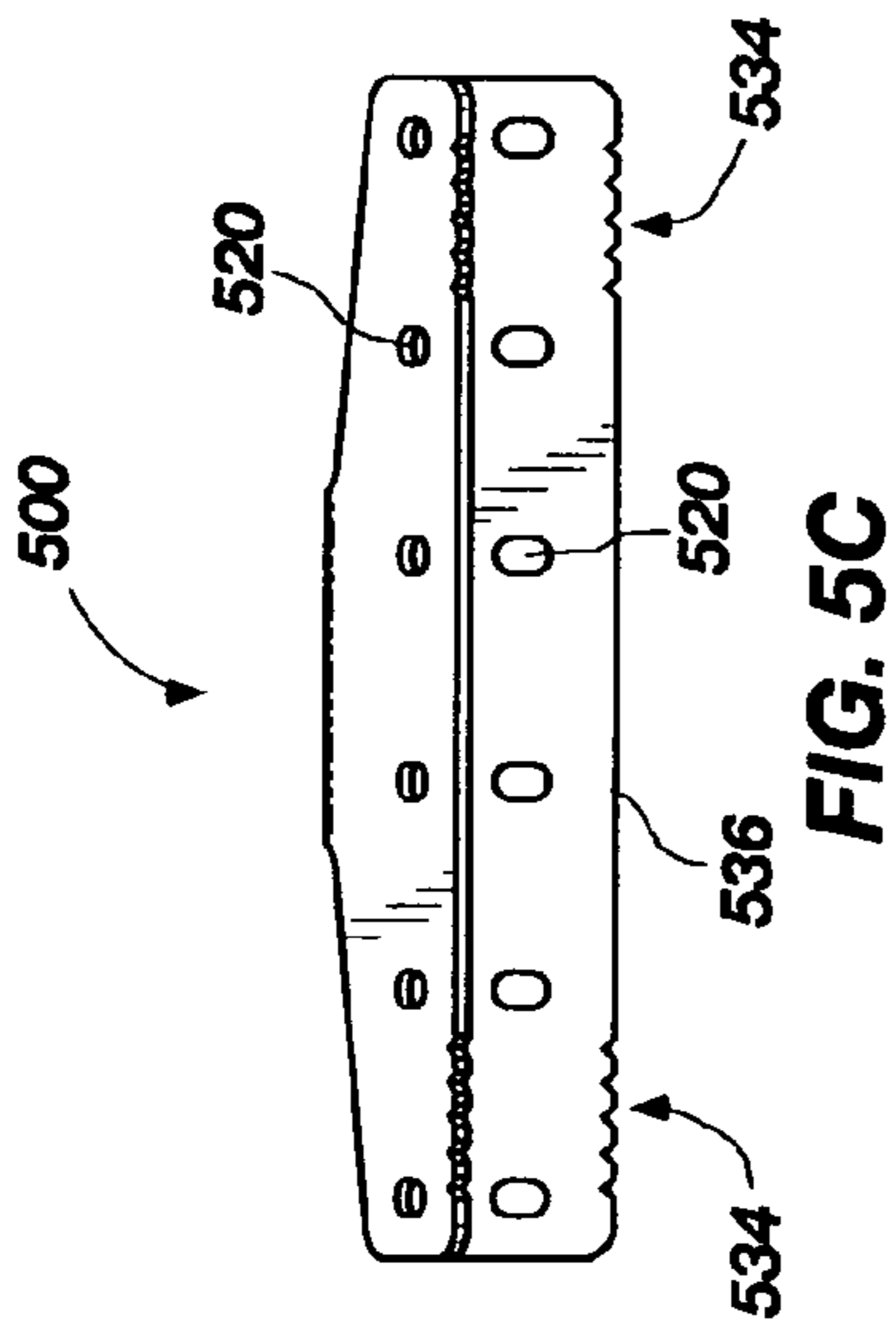

FIG. 5B

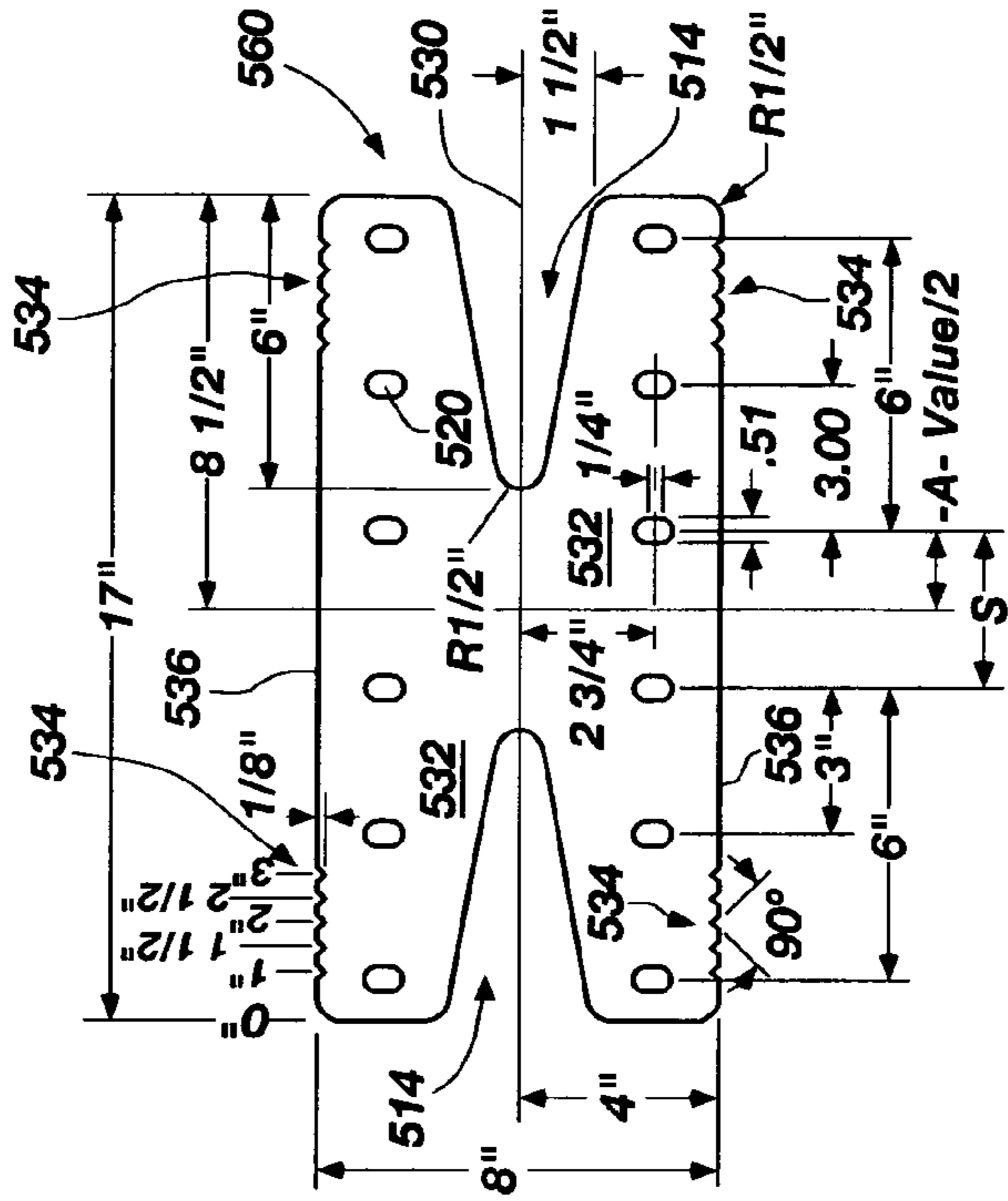

FIG. 5C

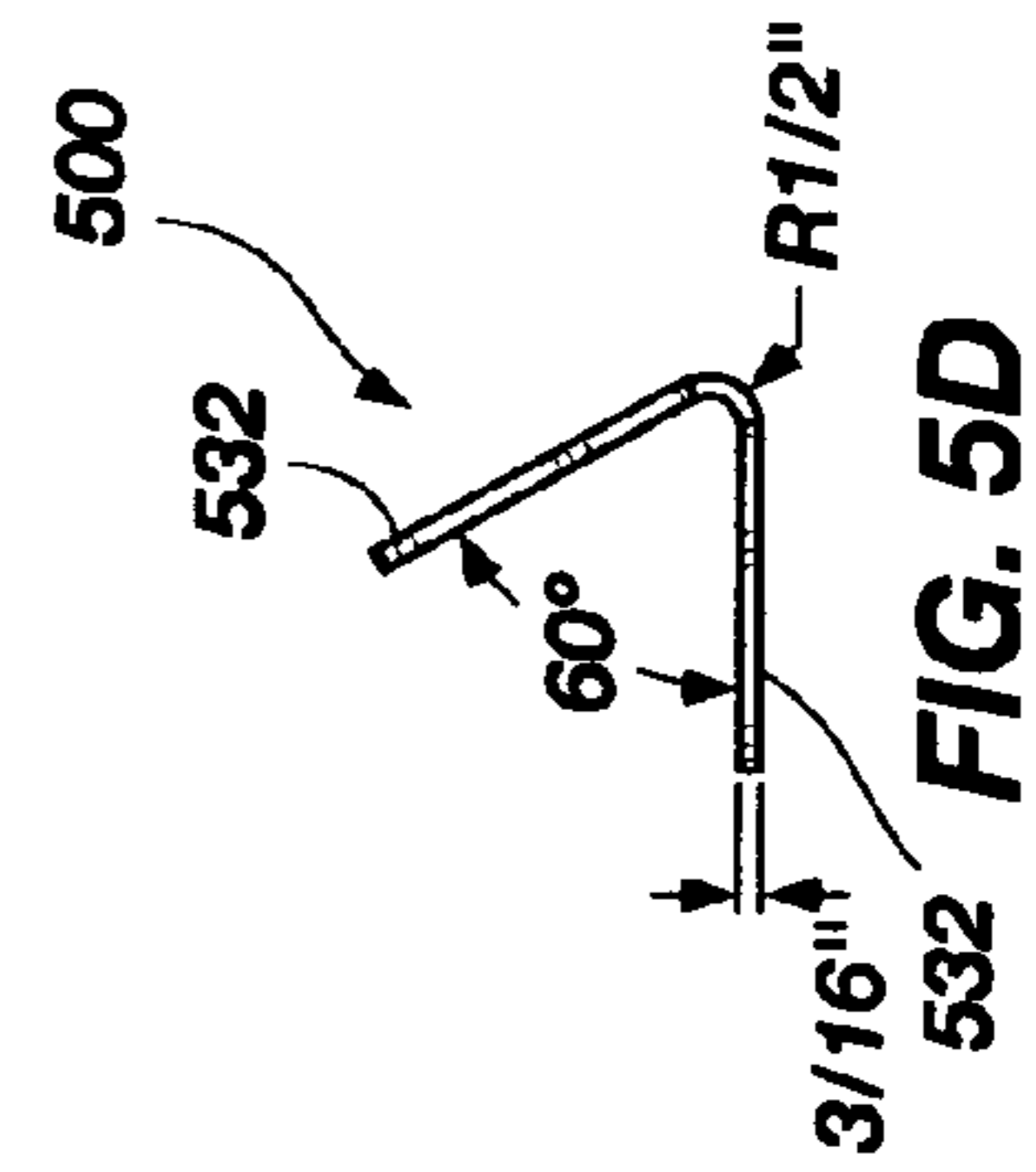

FIG. 5D

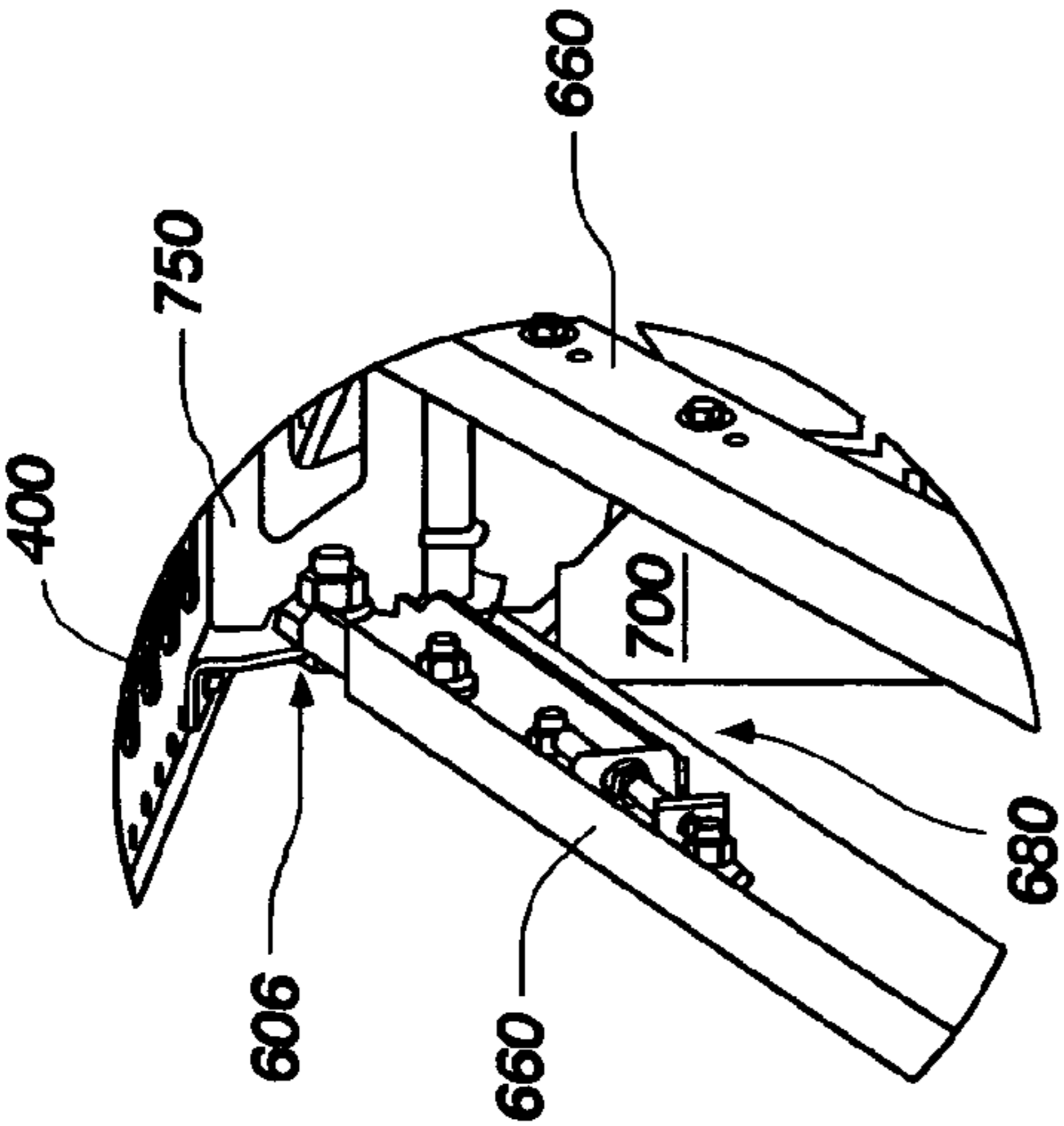

FIG. 6C

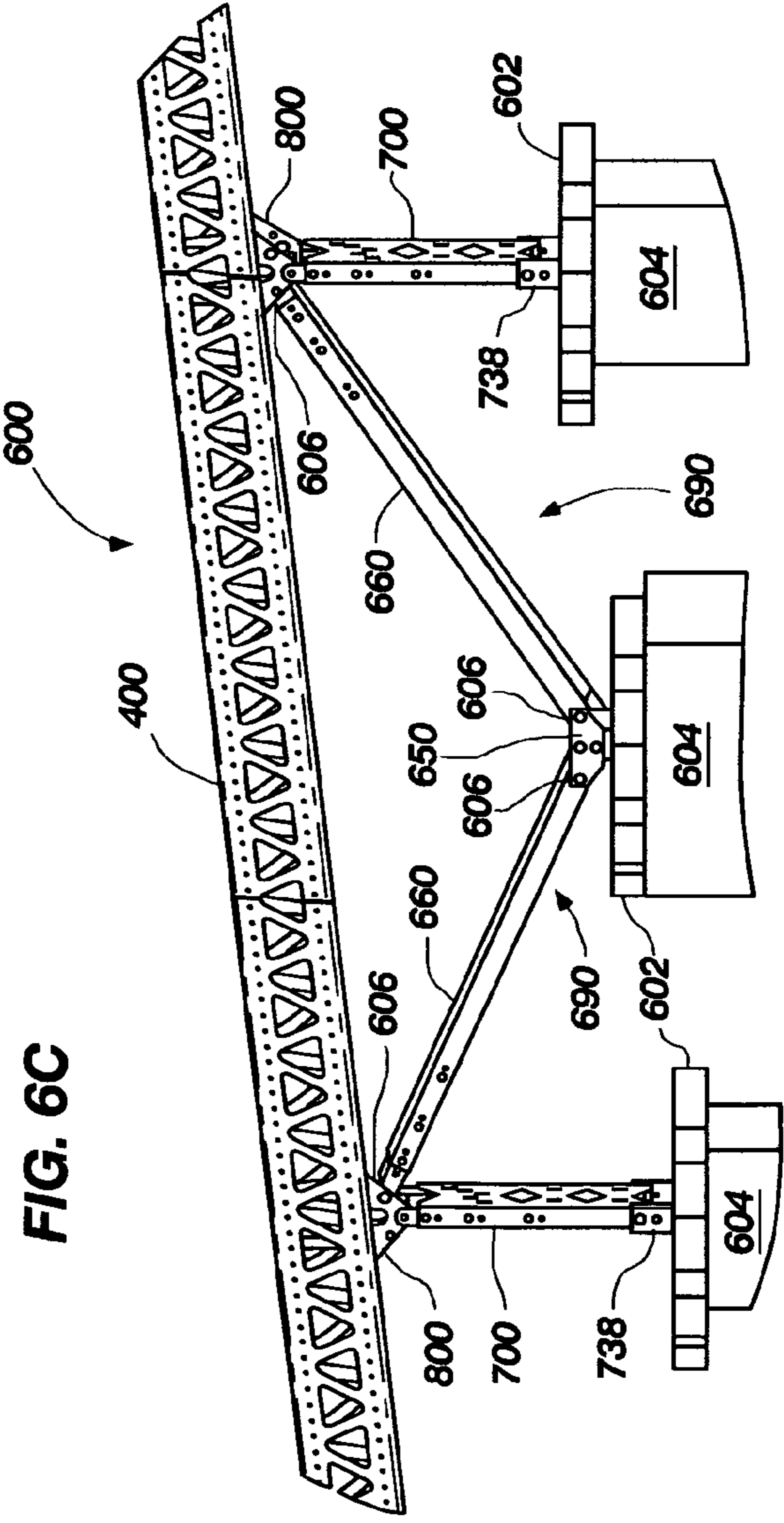

FIG. 6A

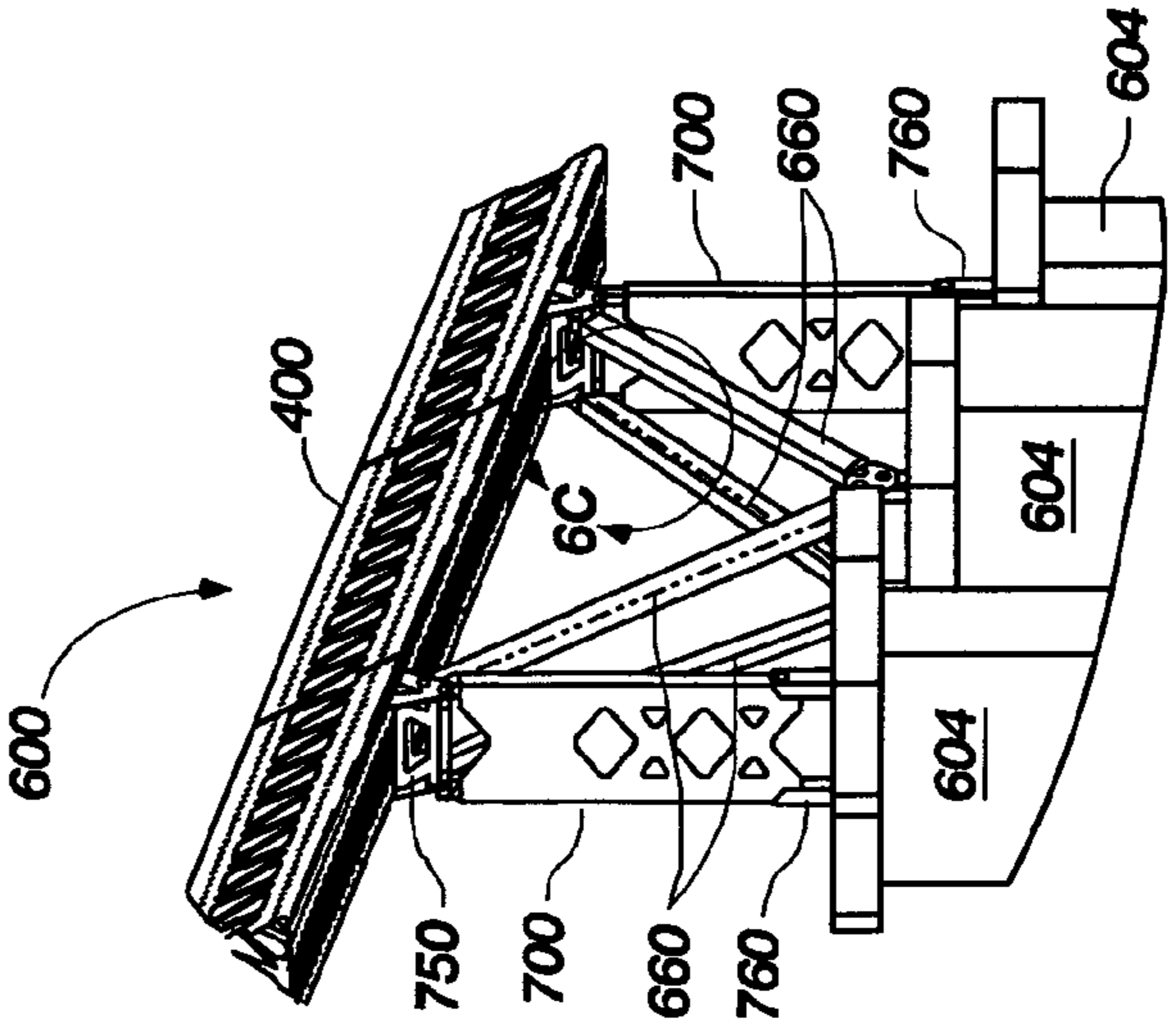
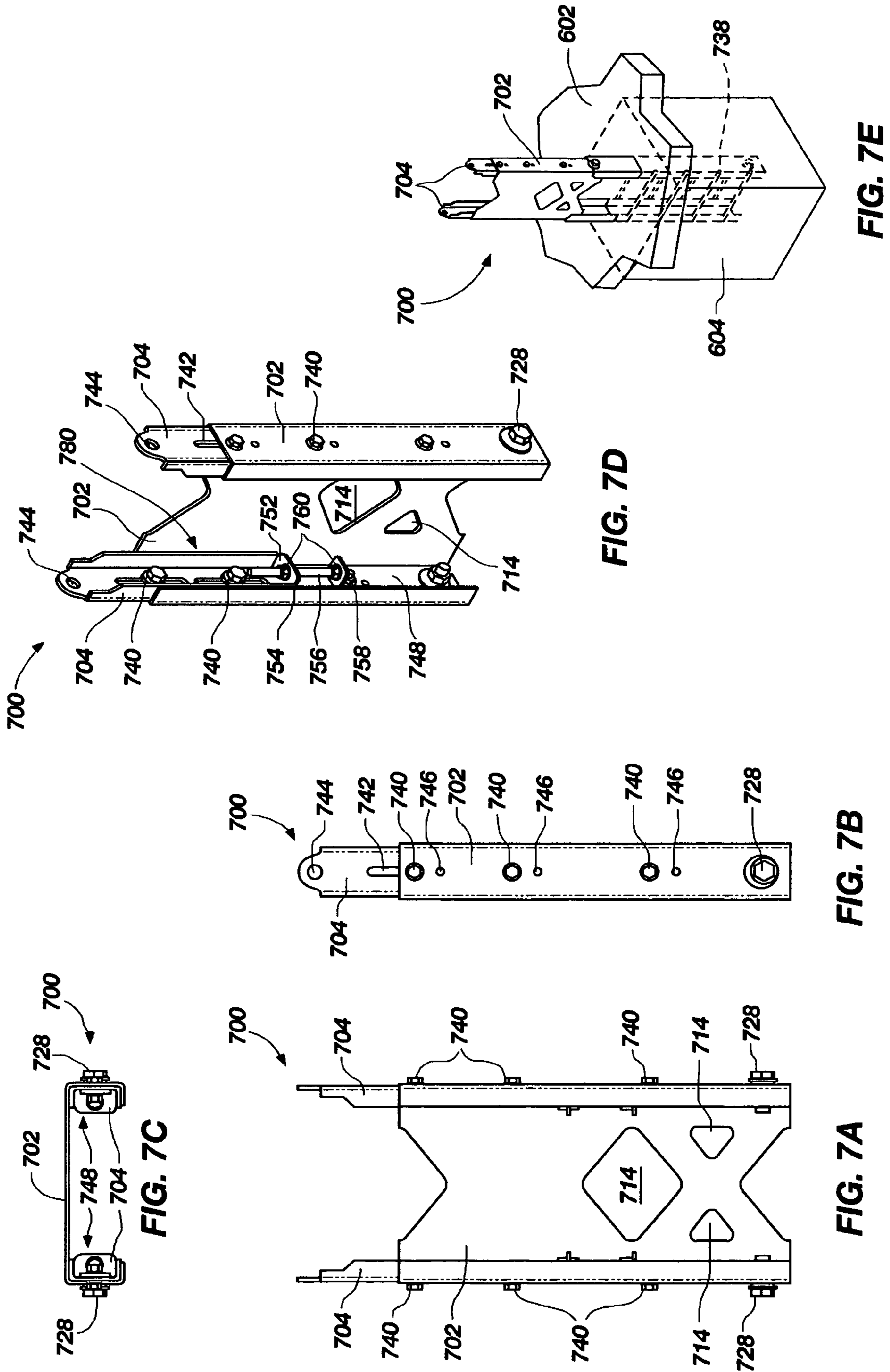

FIG. 6B



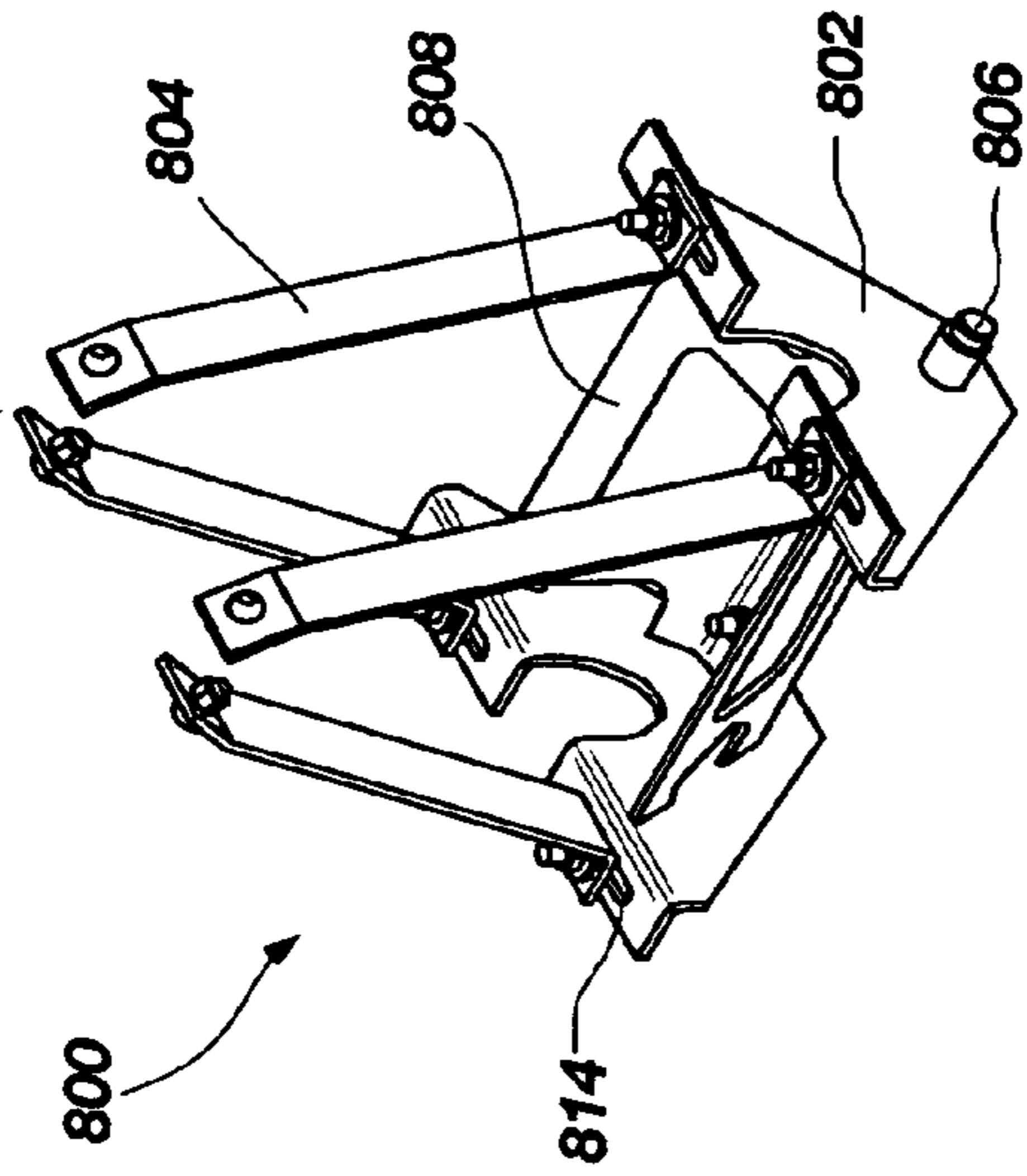

FIG. 8D

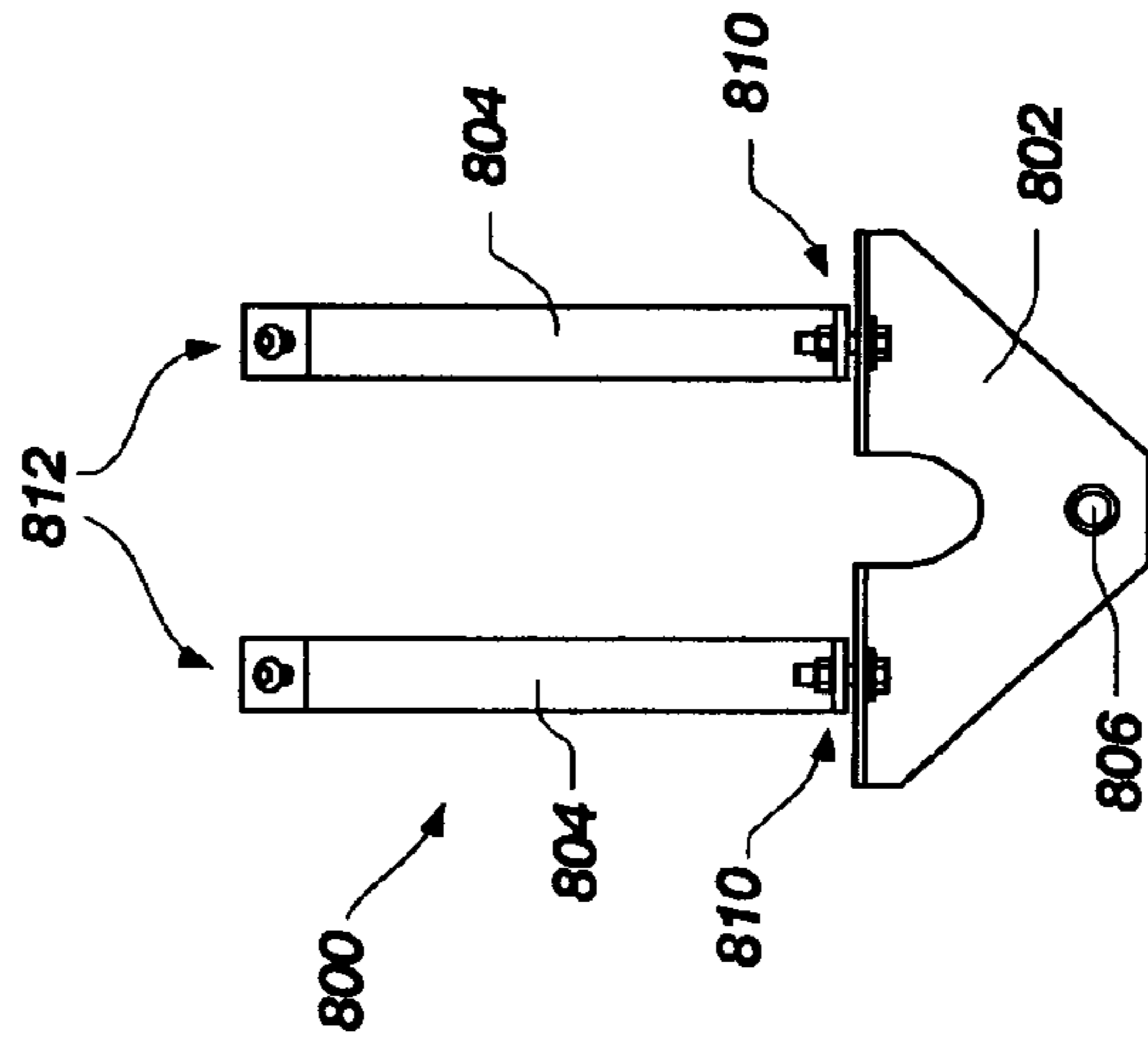

FIG. 8A

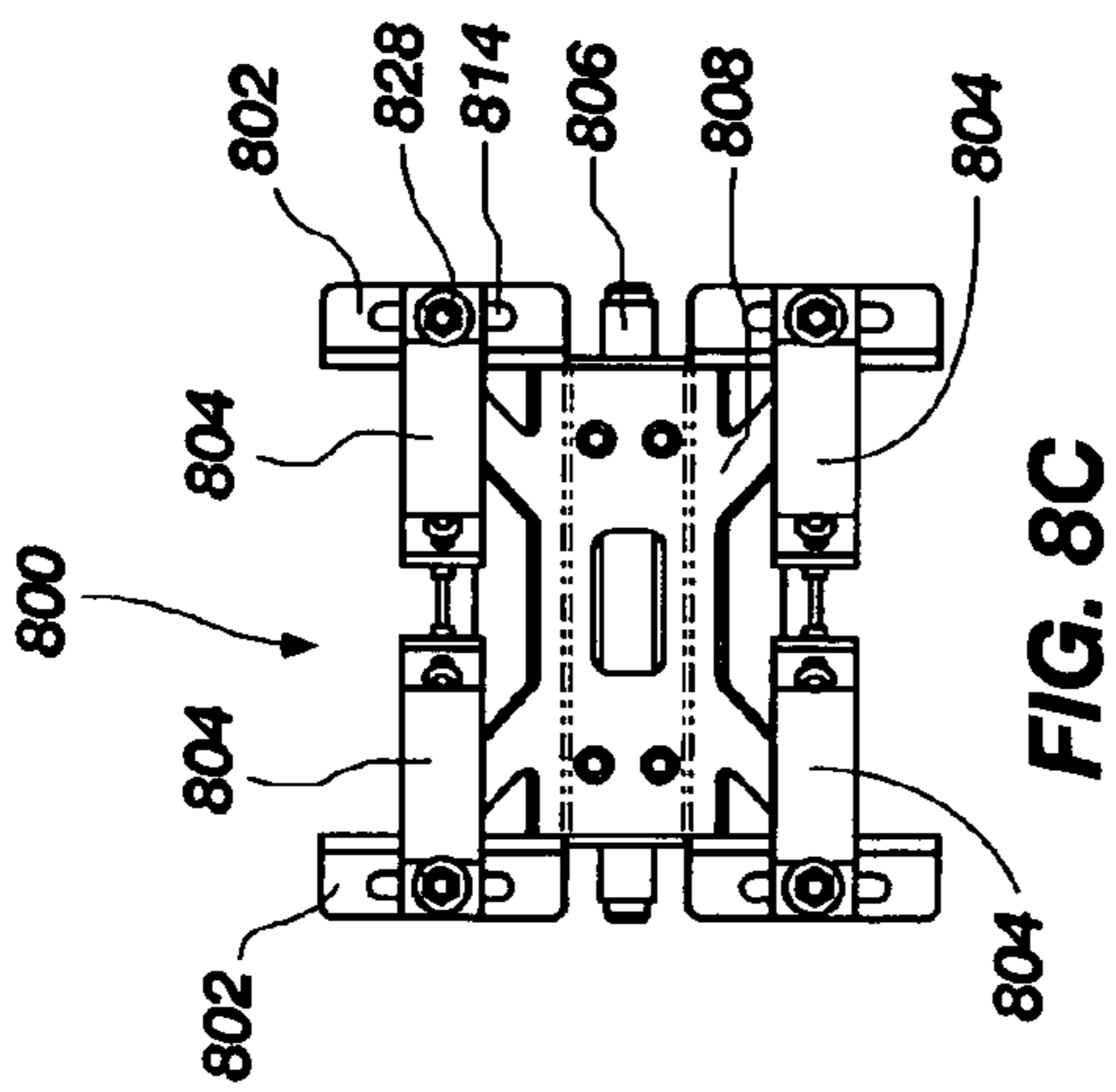

FIG. 8C

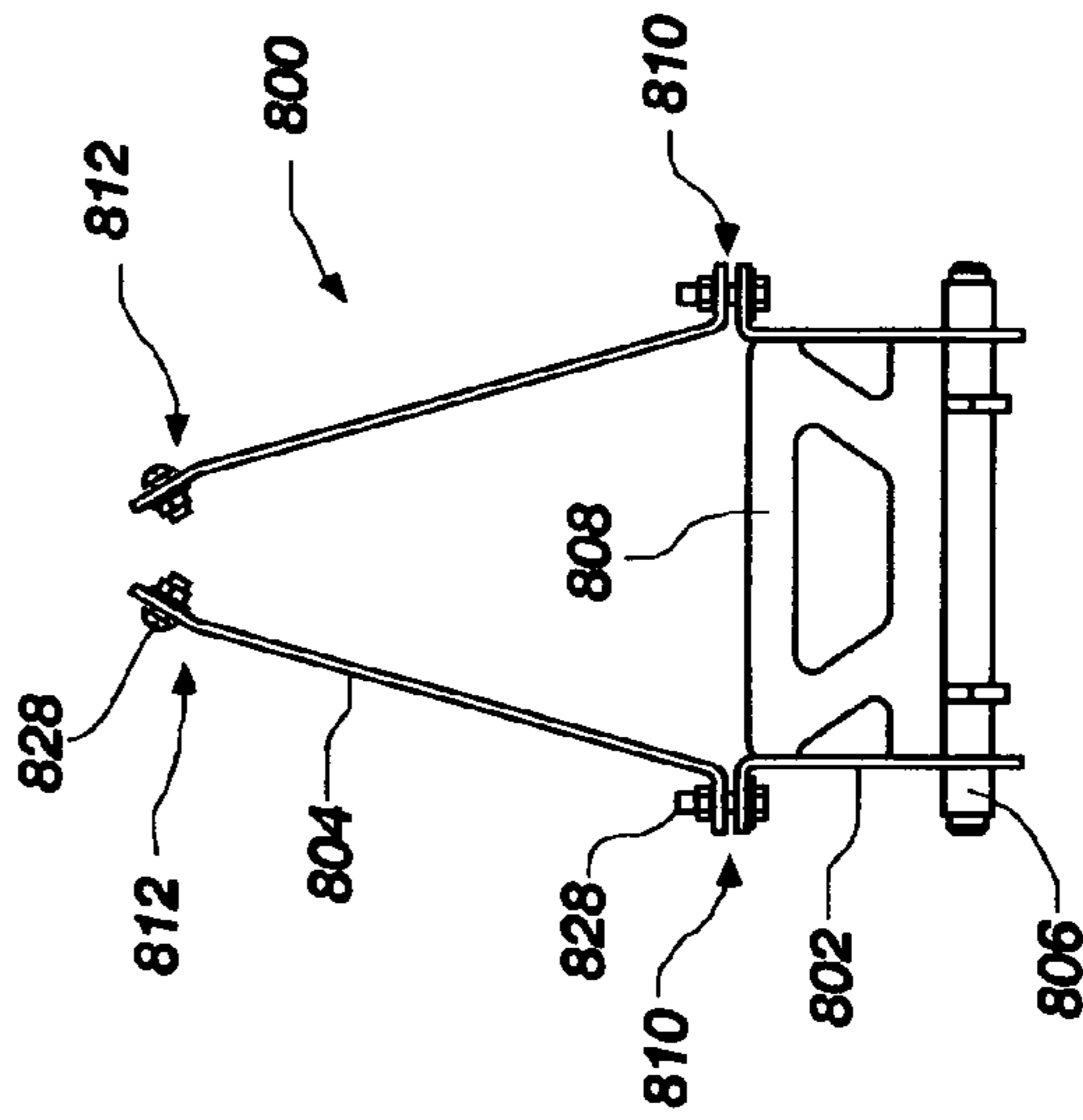

FIG. 8B

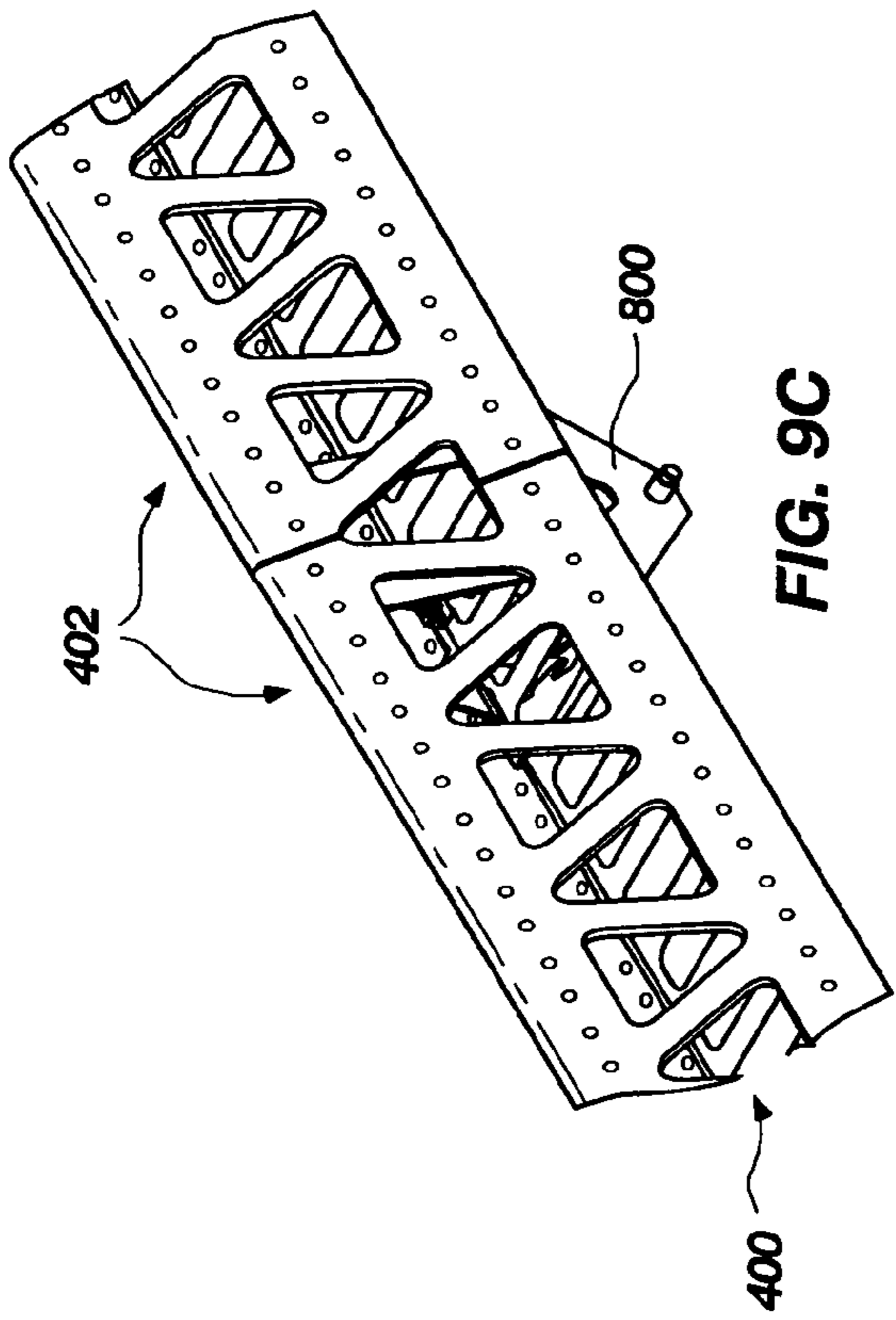

FIG. 9C

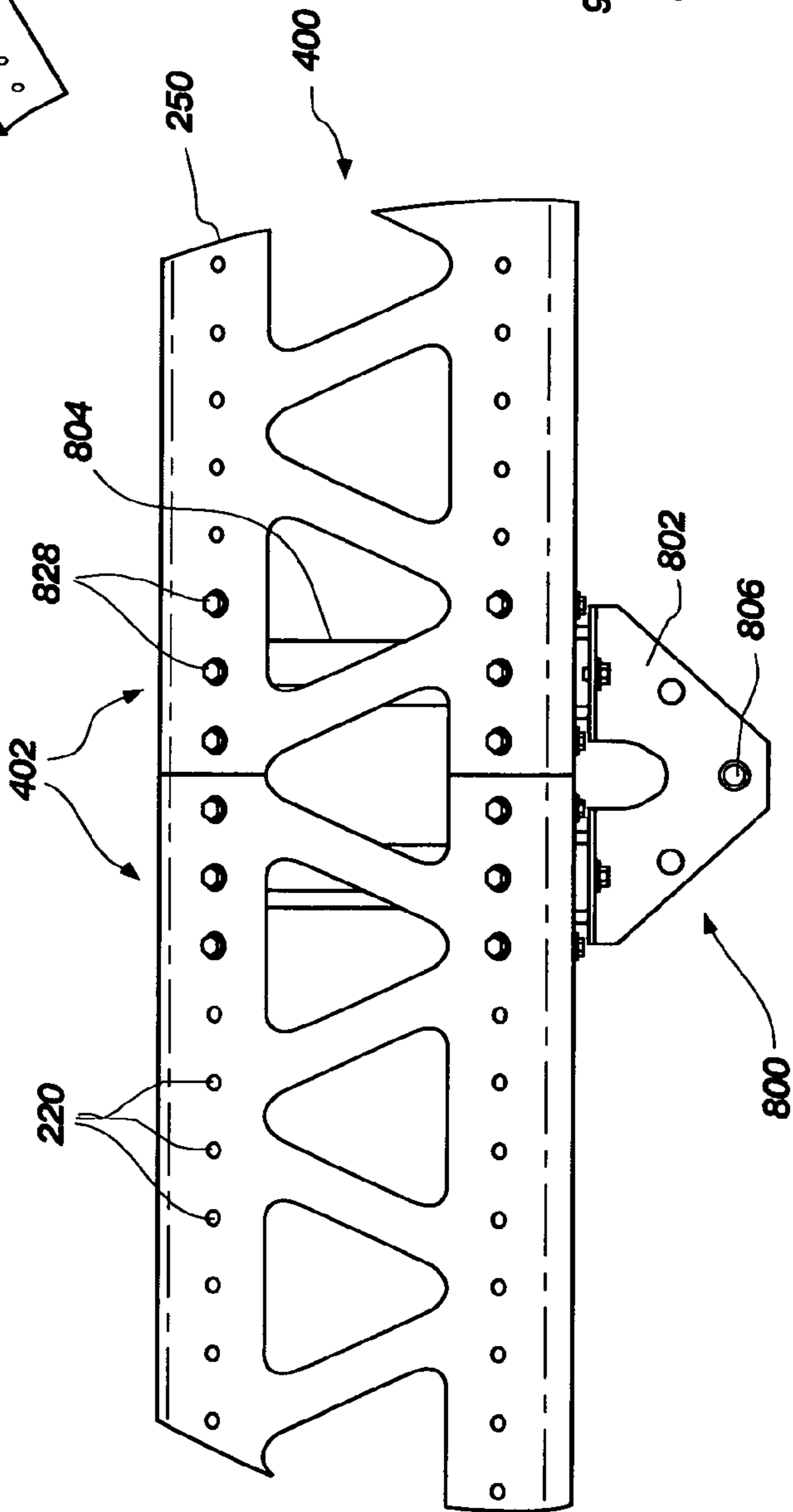

FIG. 9A

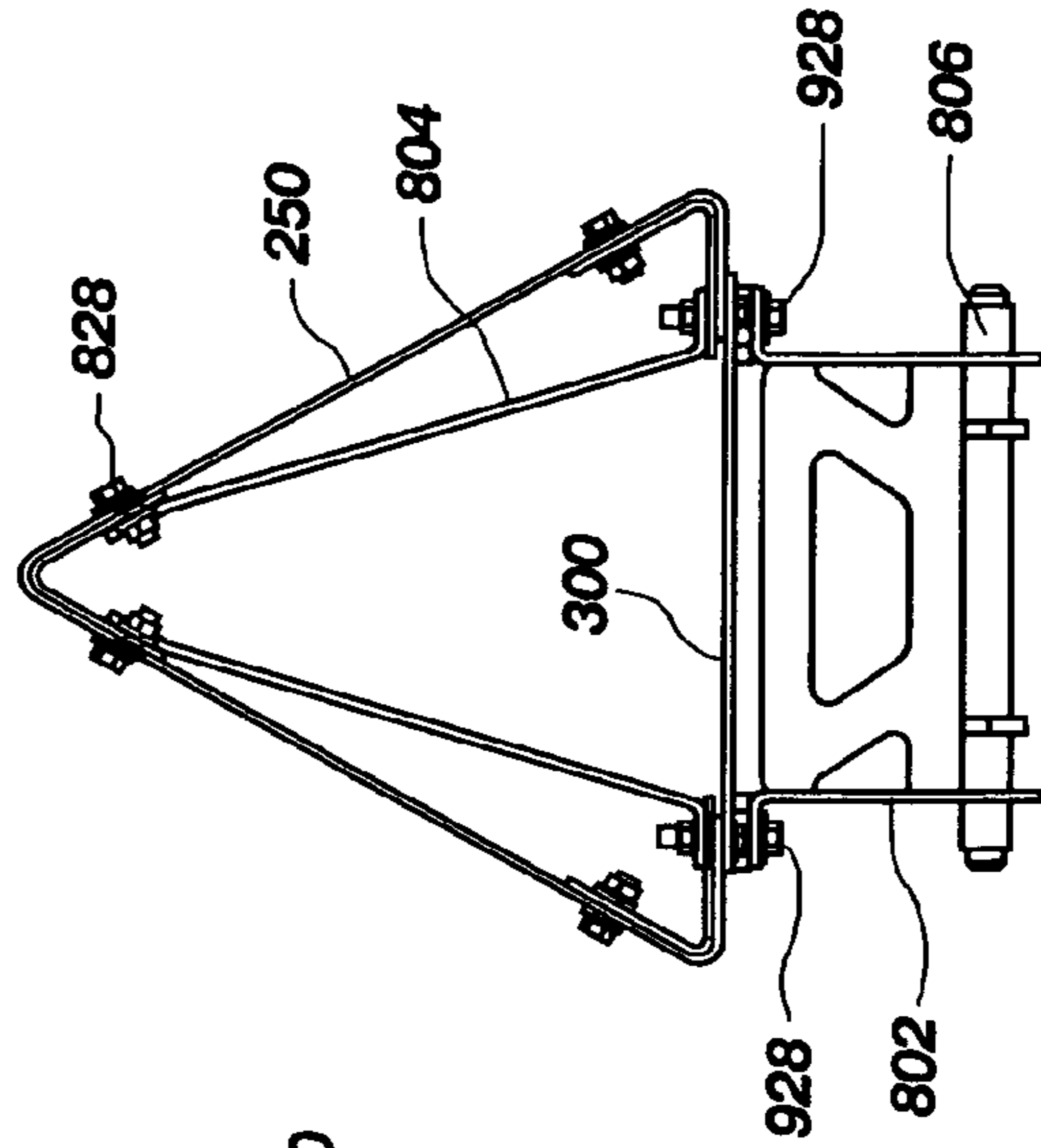

FIG. 9B

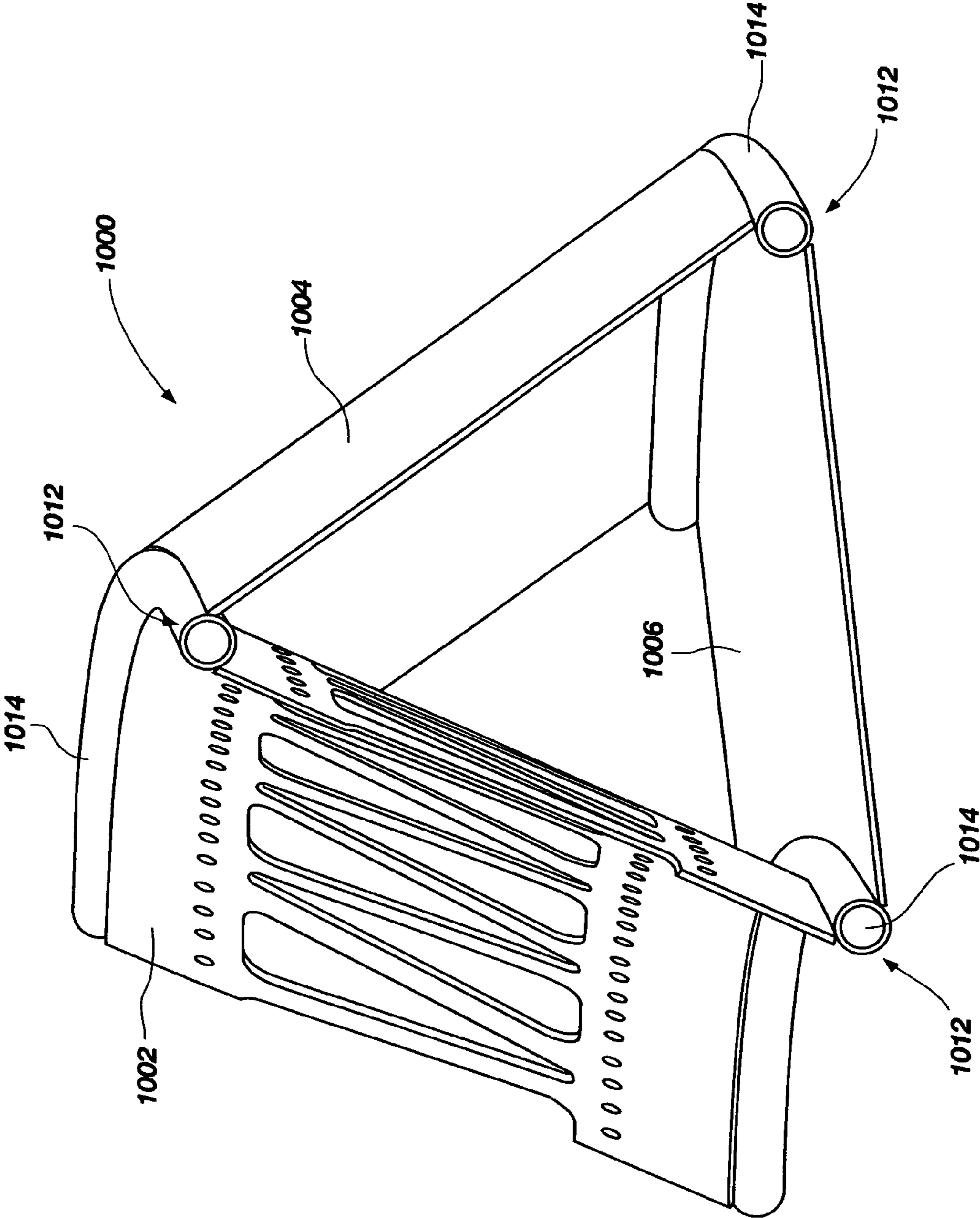

FIG. 10

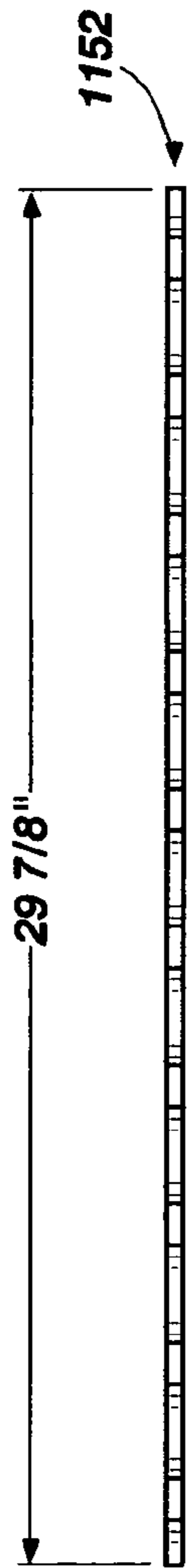

FIG. 12B

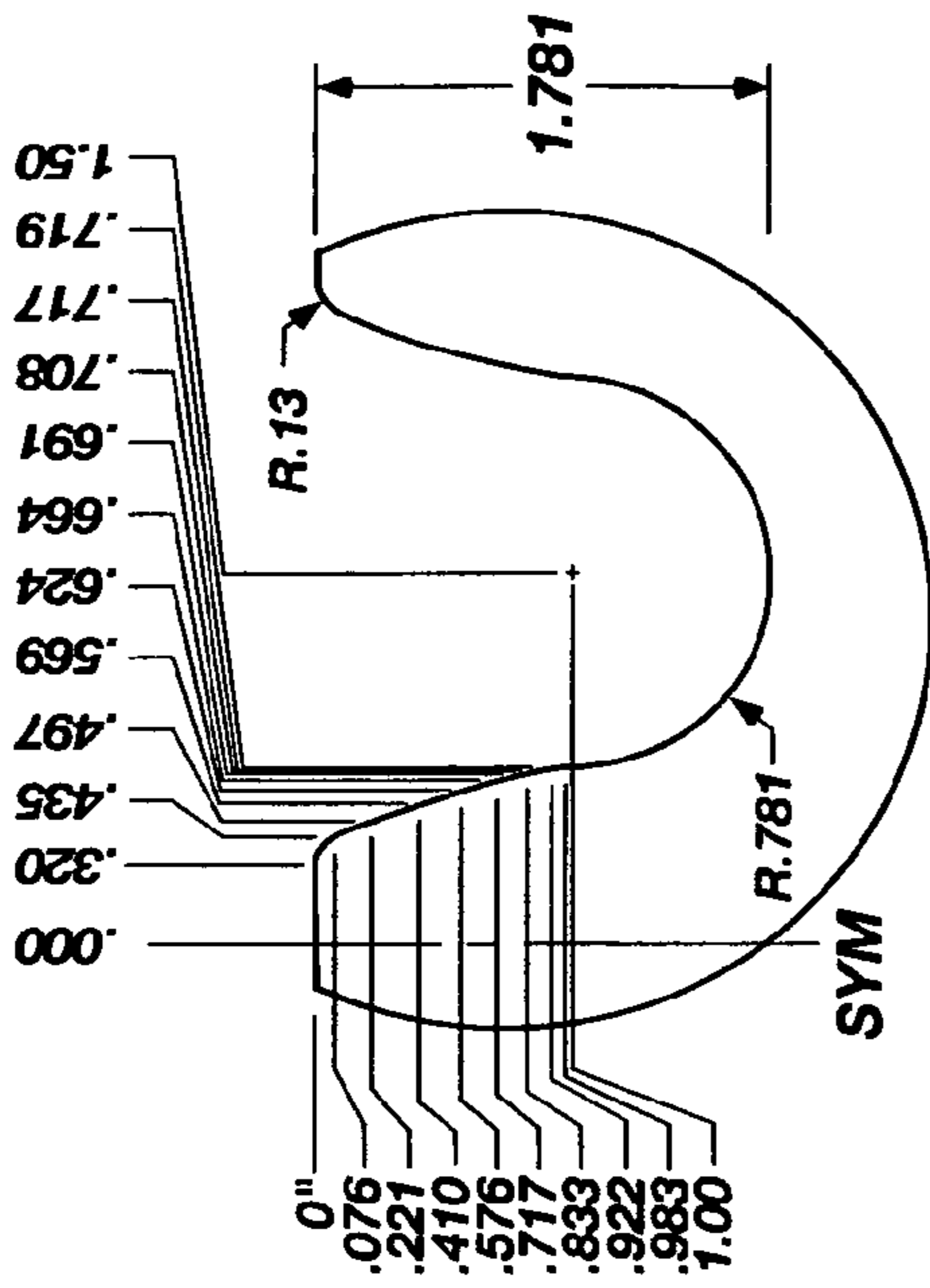

FIG. 12D

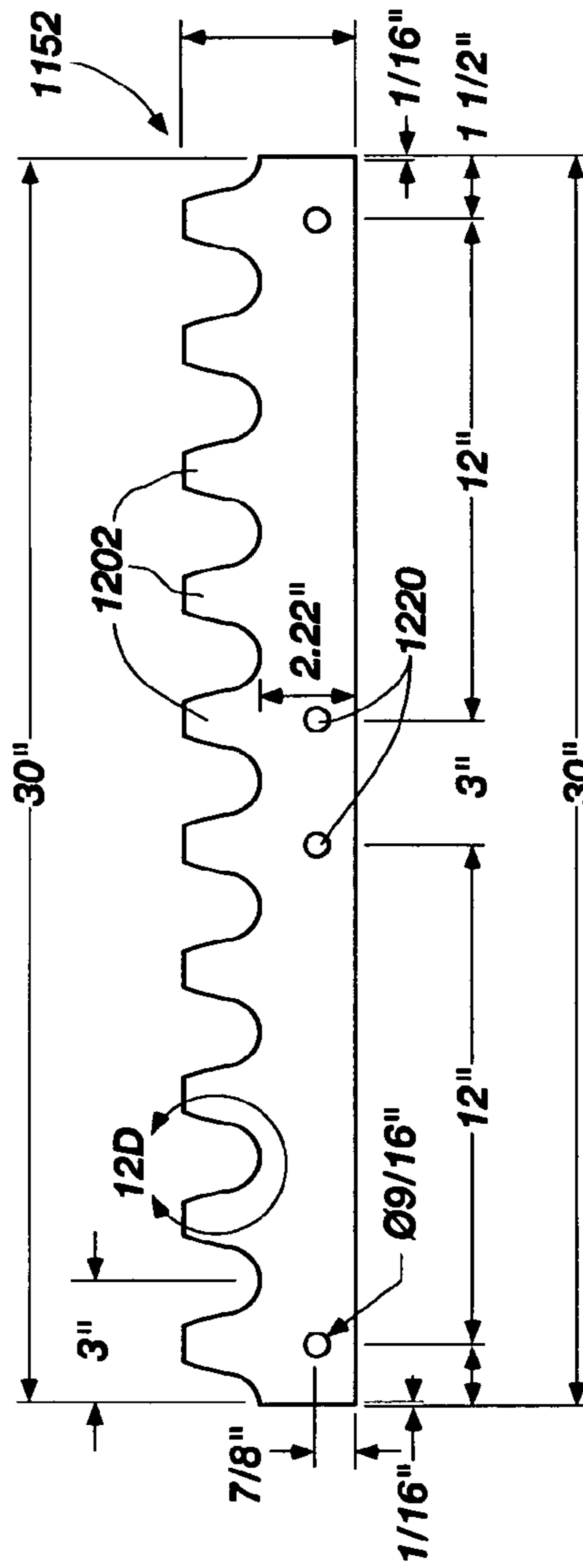

FIG. 12A

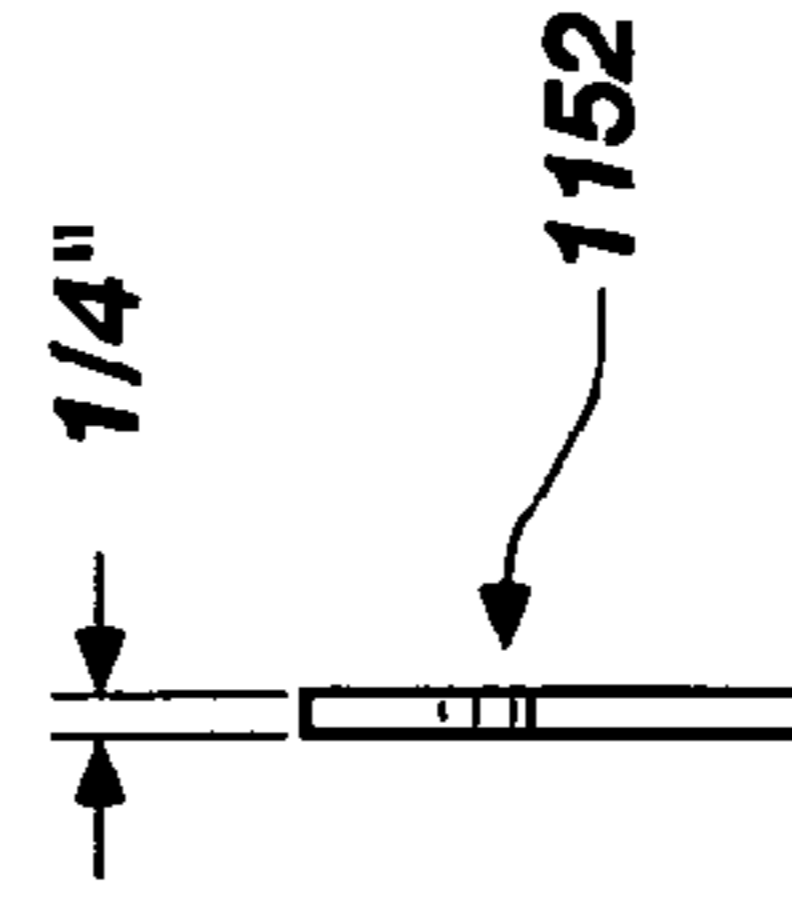

FIG. 12C

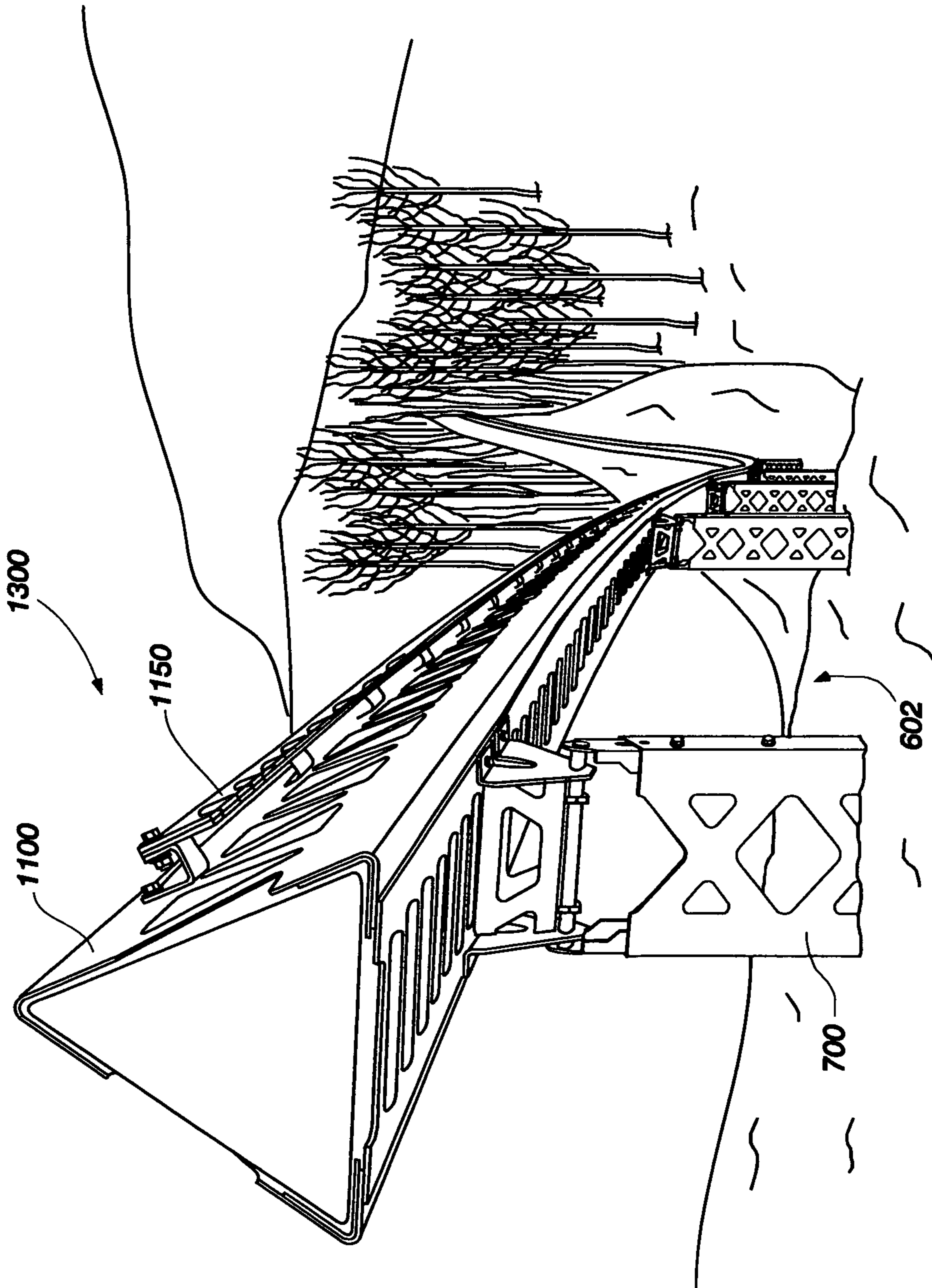

FIG. 13

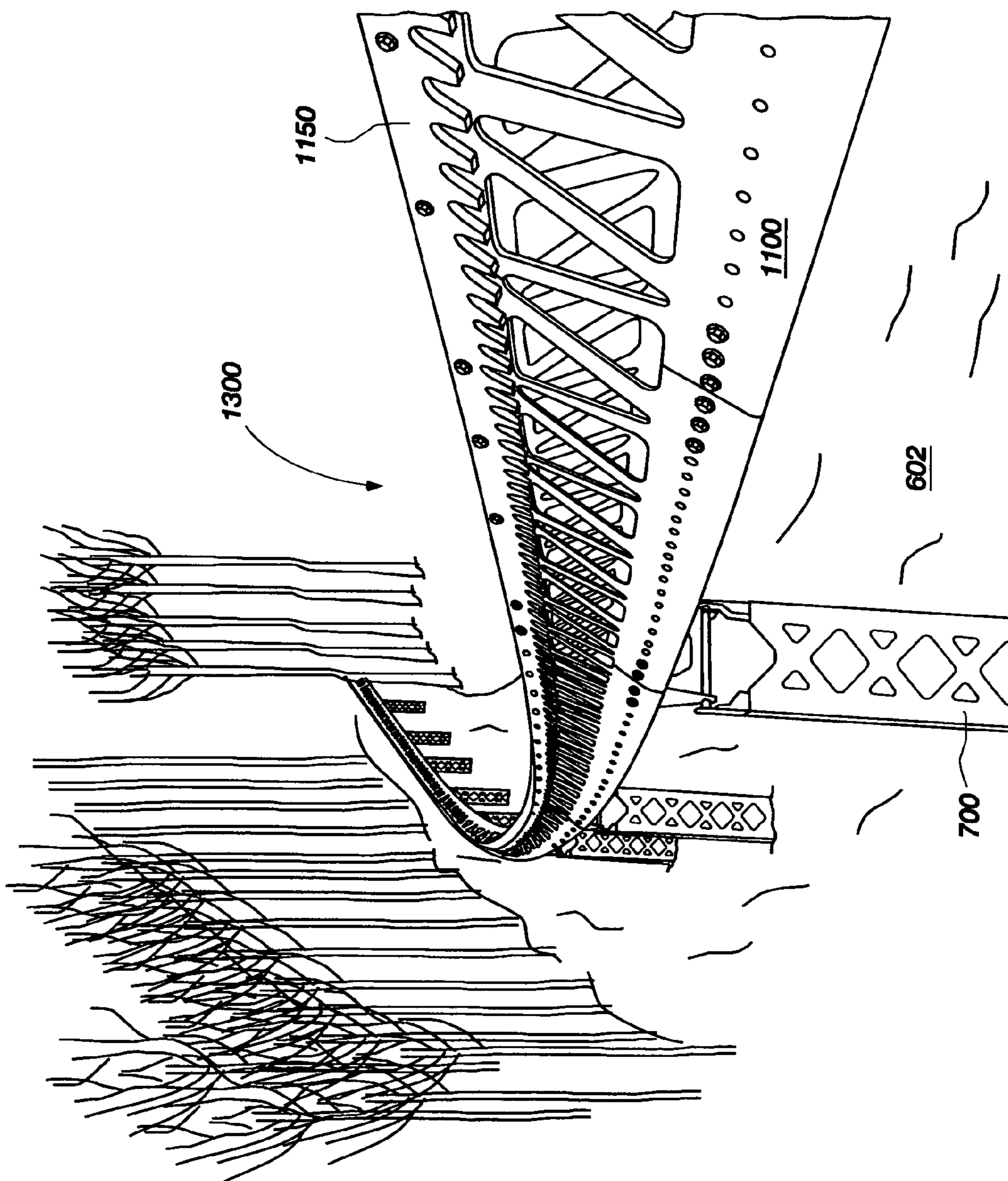

FIG. 14

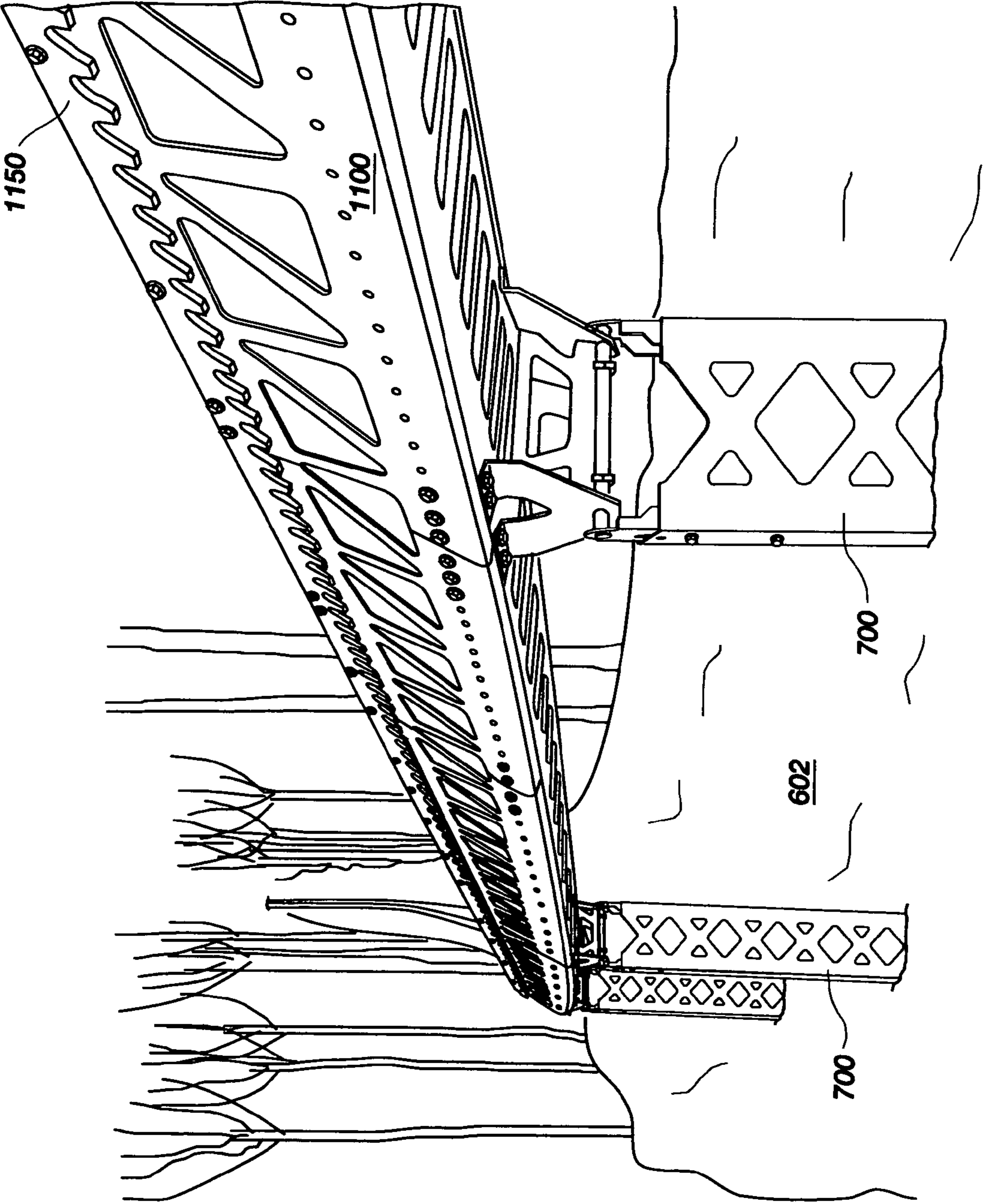

FIG. 15

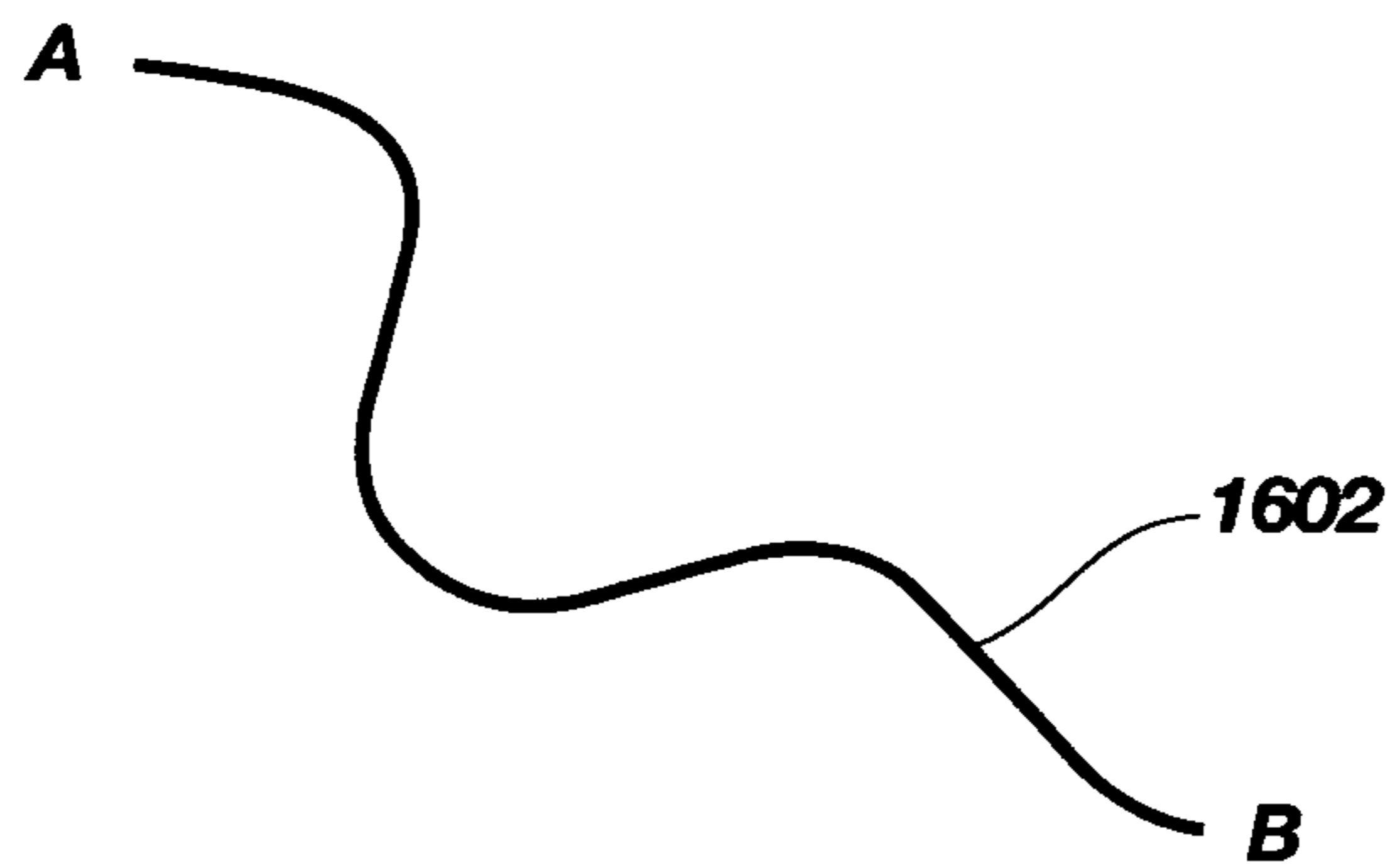

FIG. 16A

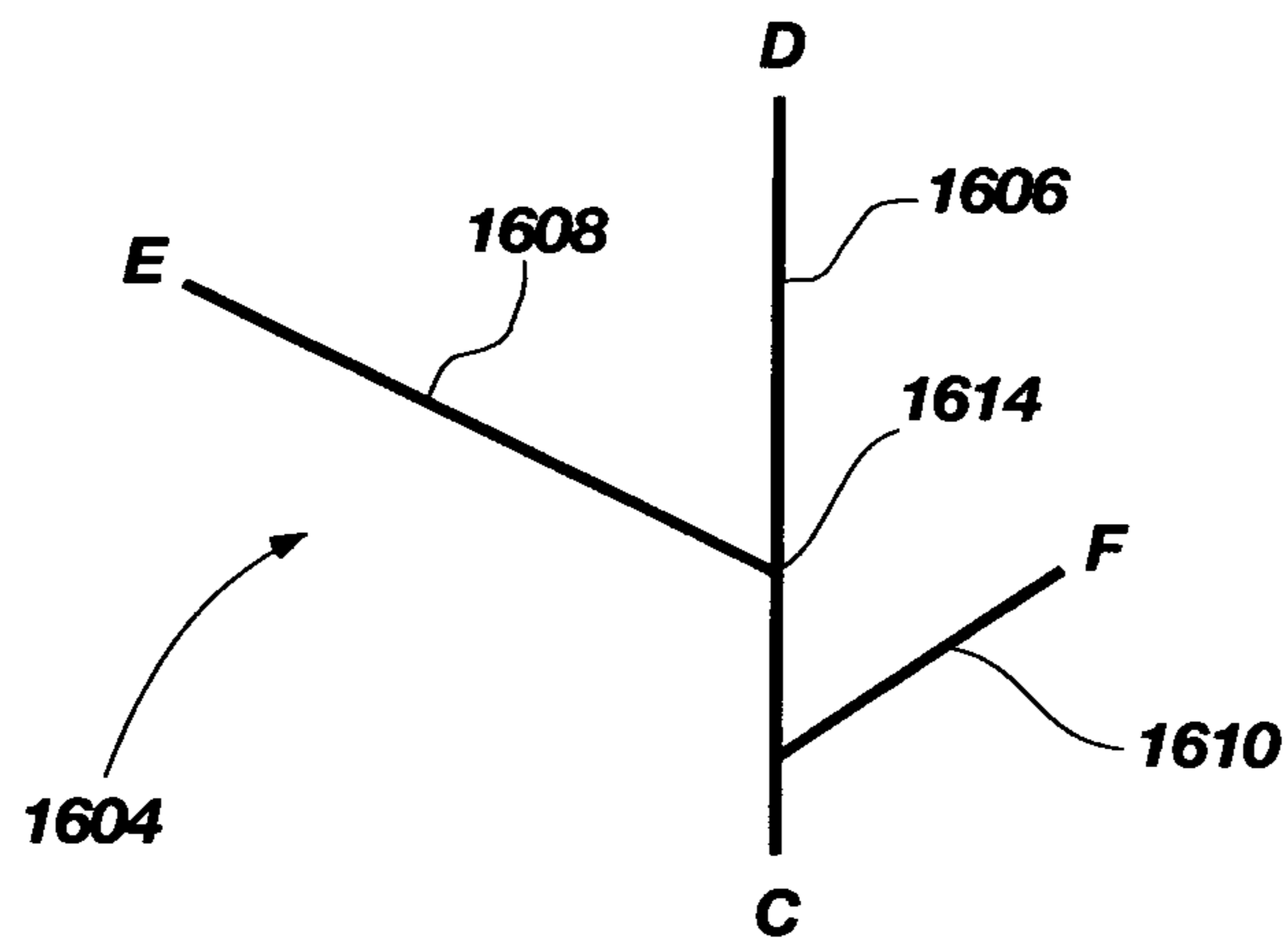

FIG. 16B

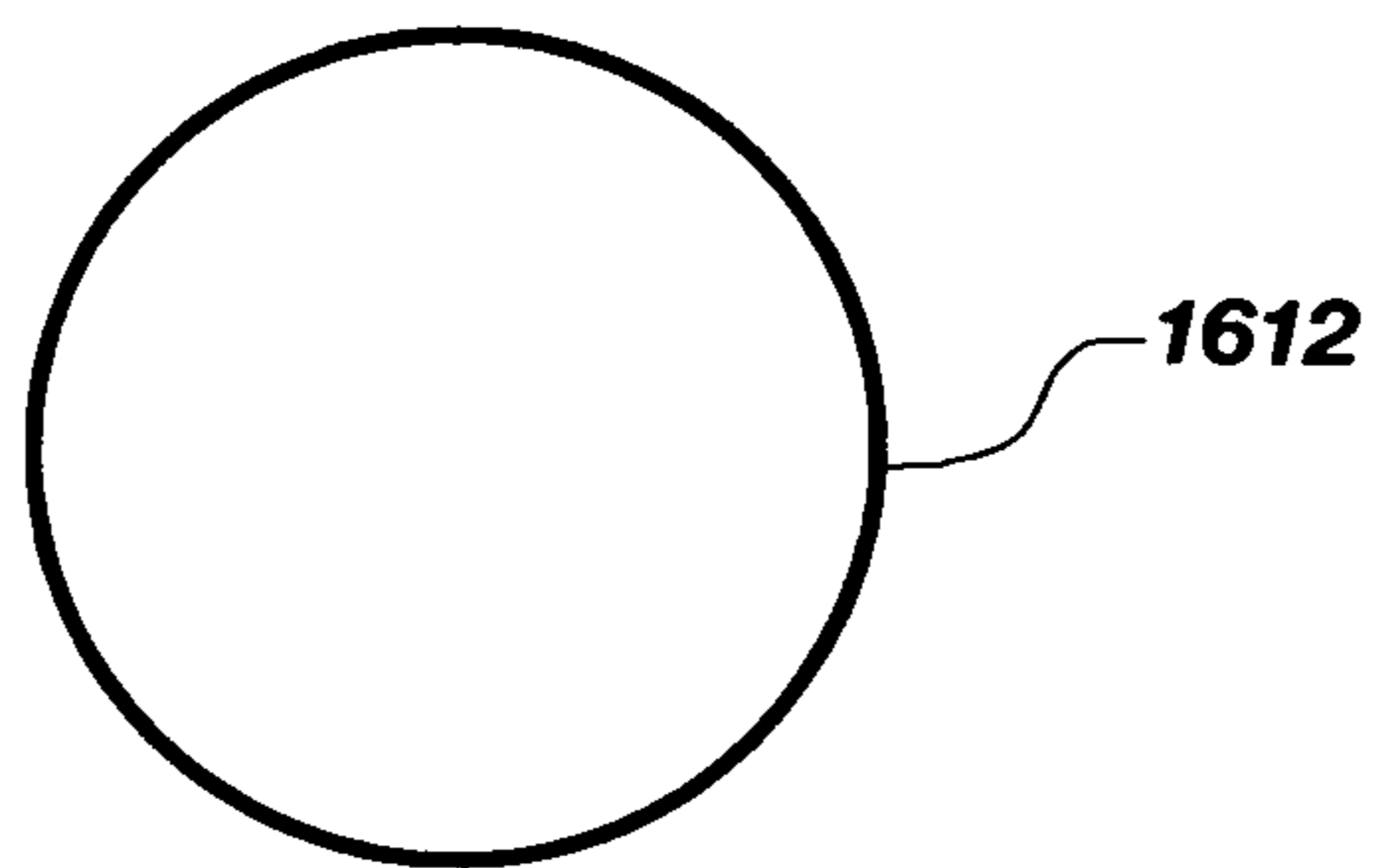

FIG. 16C

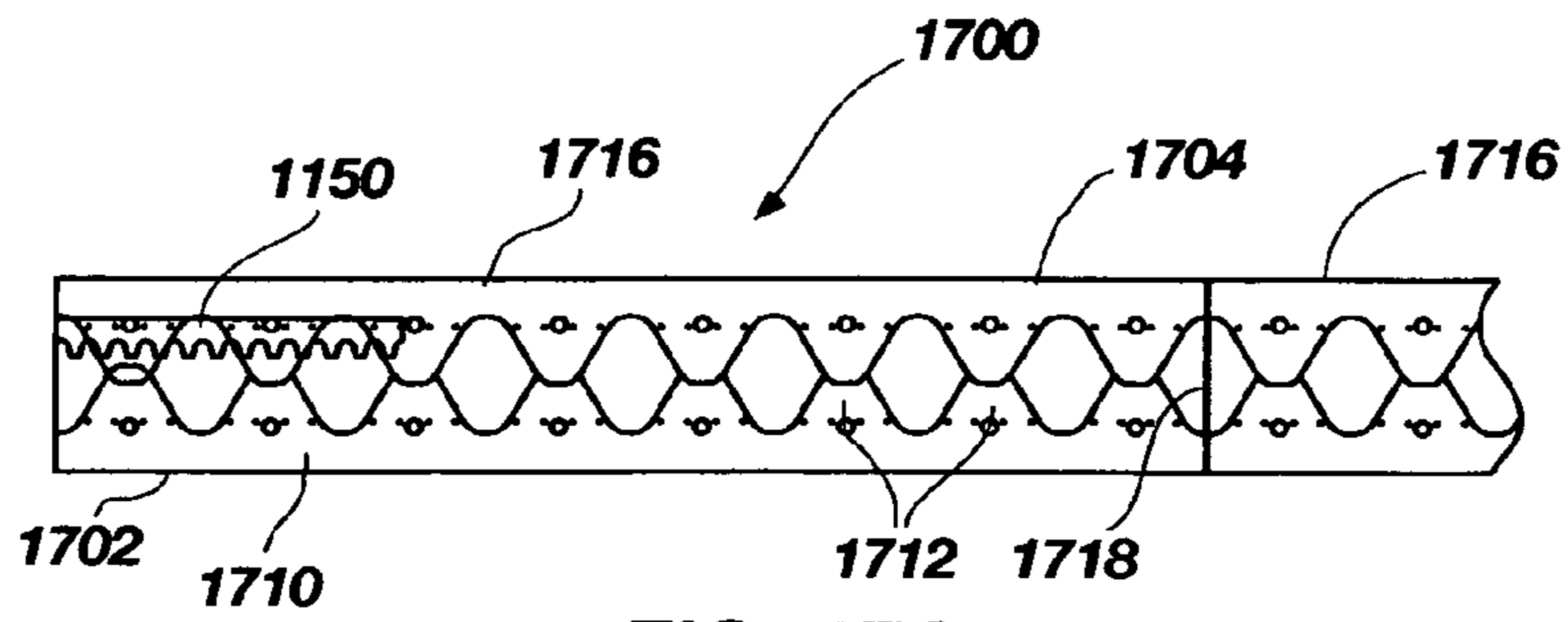

FIG. 17A

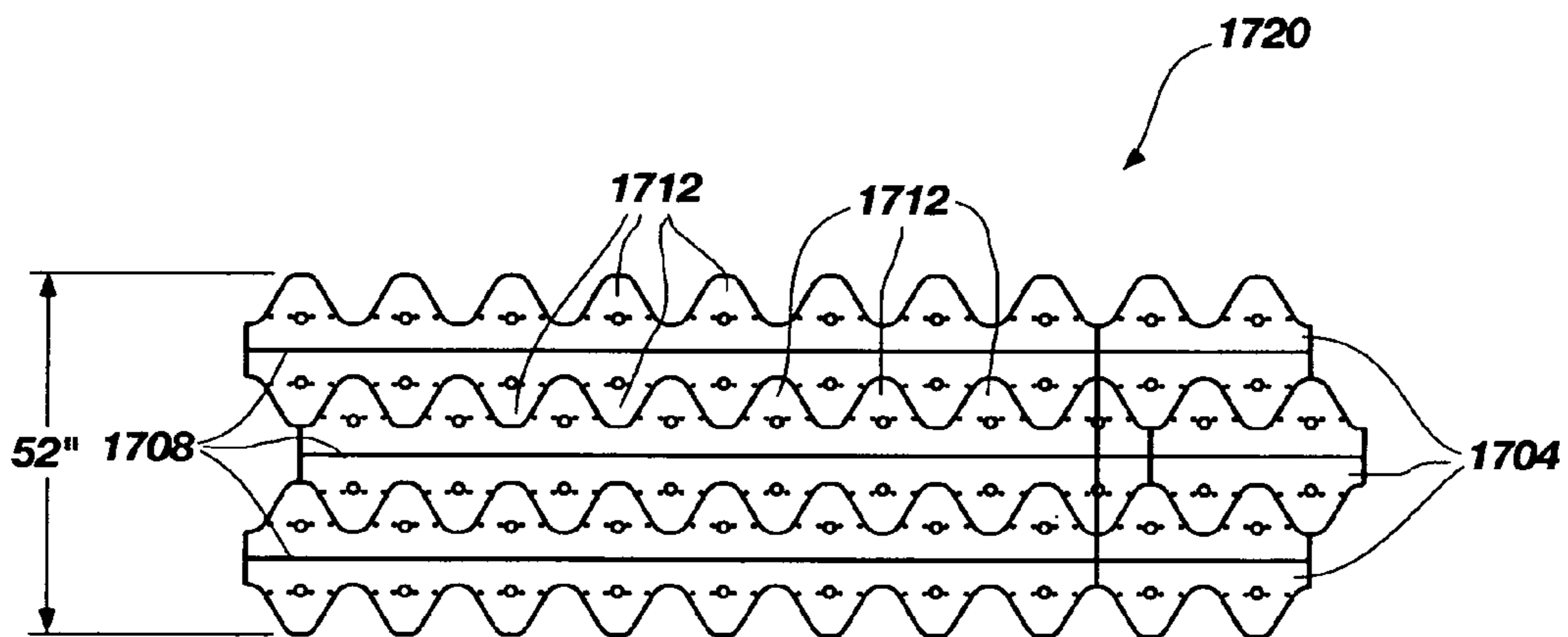

FIG. 17B

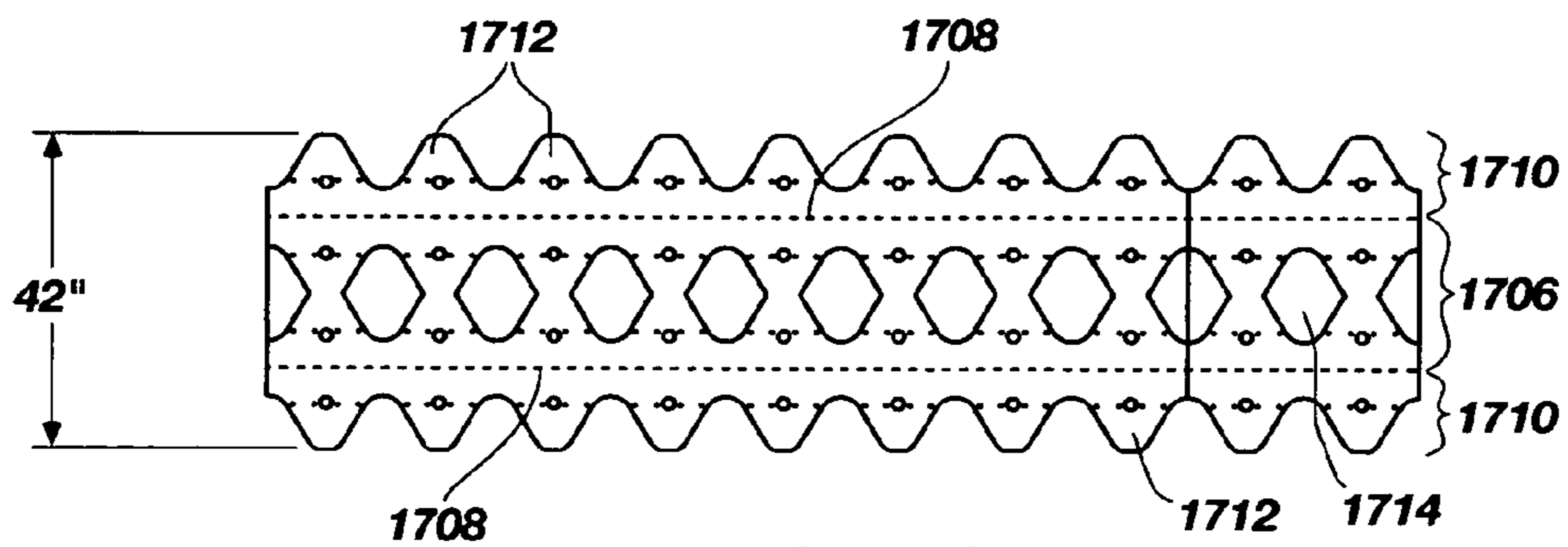

FIG. 17C

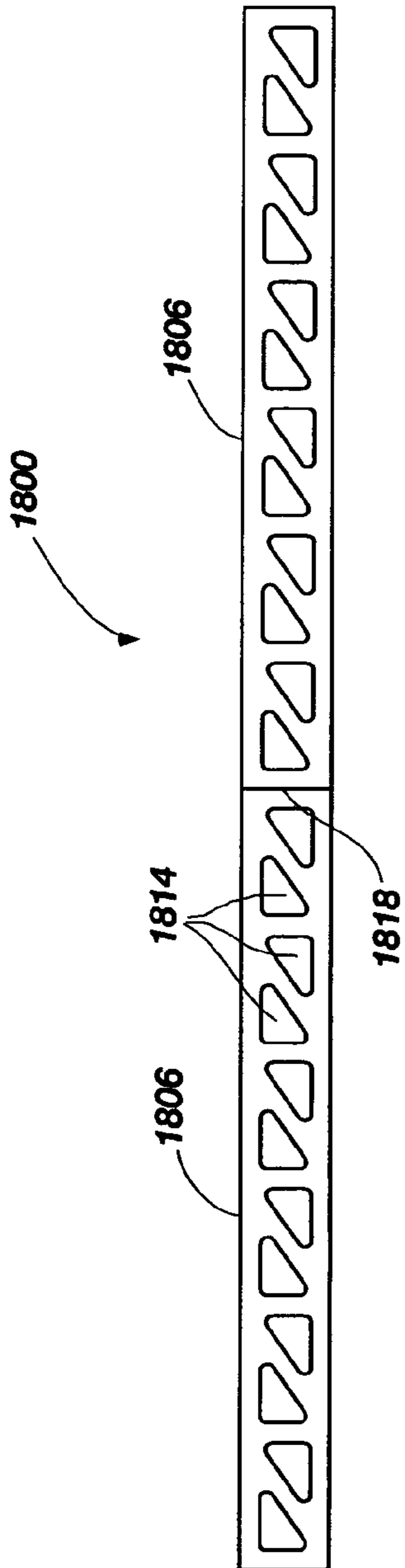

FIG. 18A

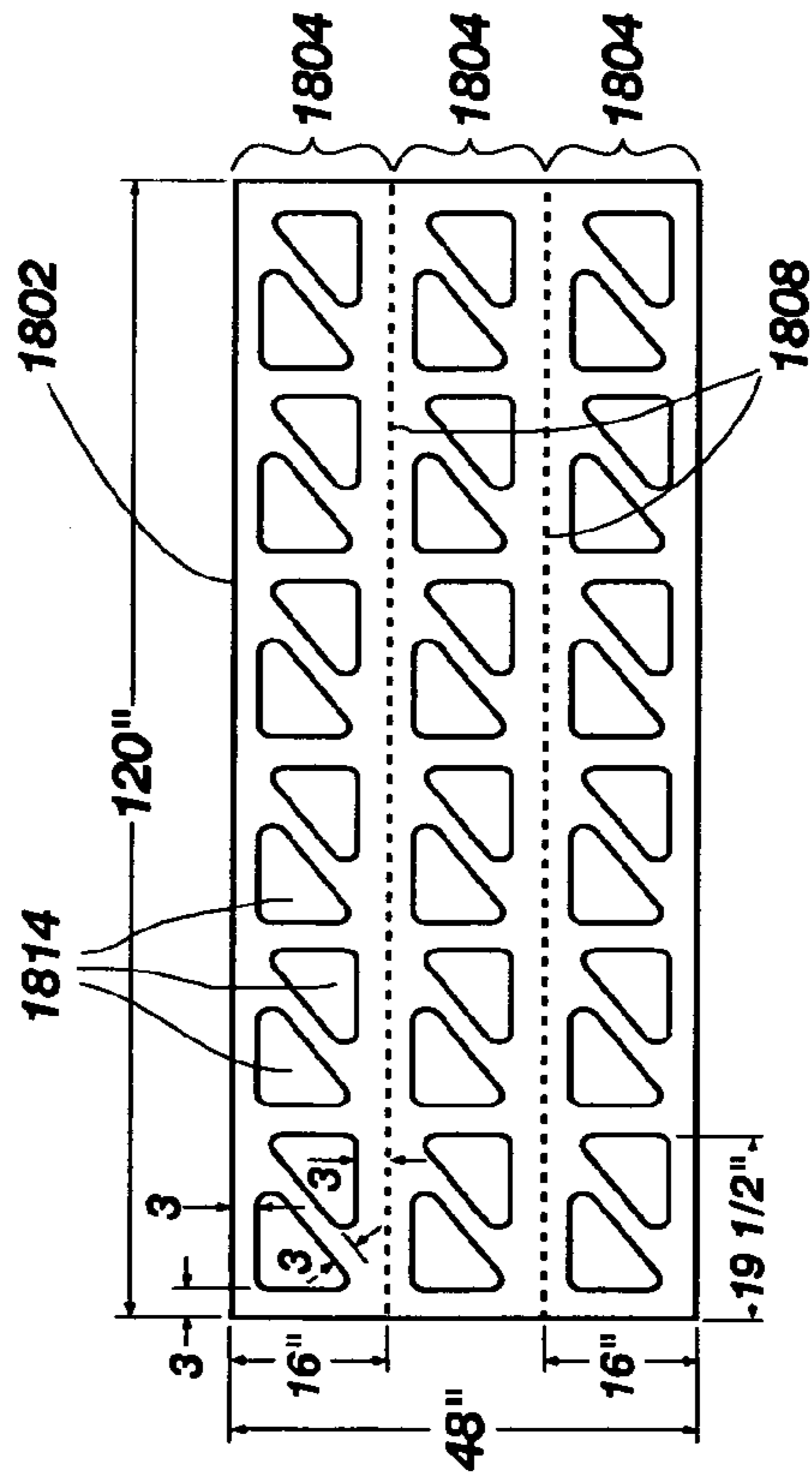

FIG. 18B

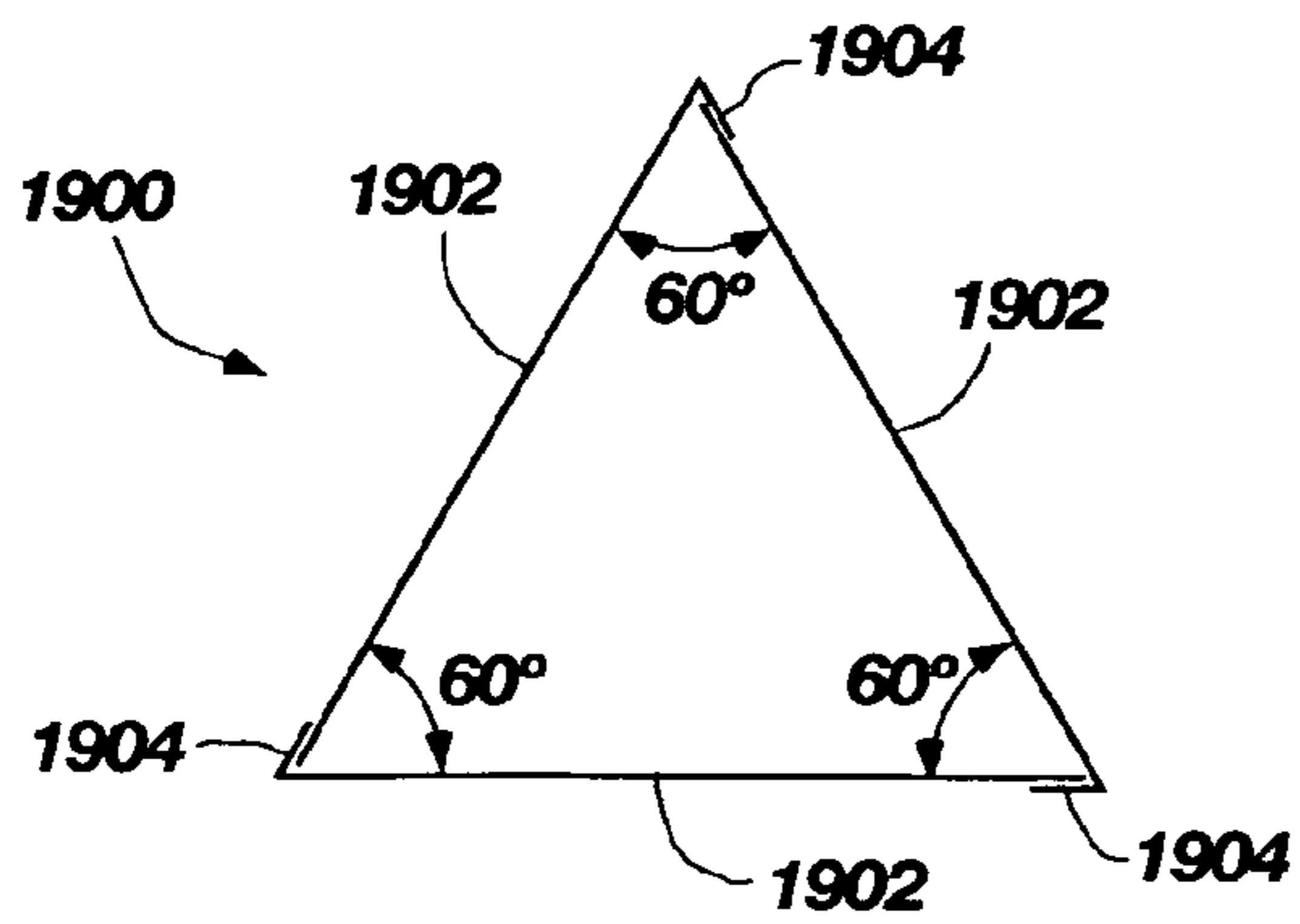

FIG. 19A

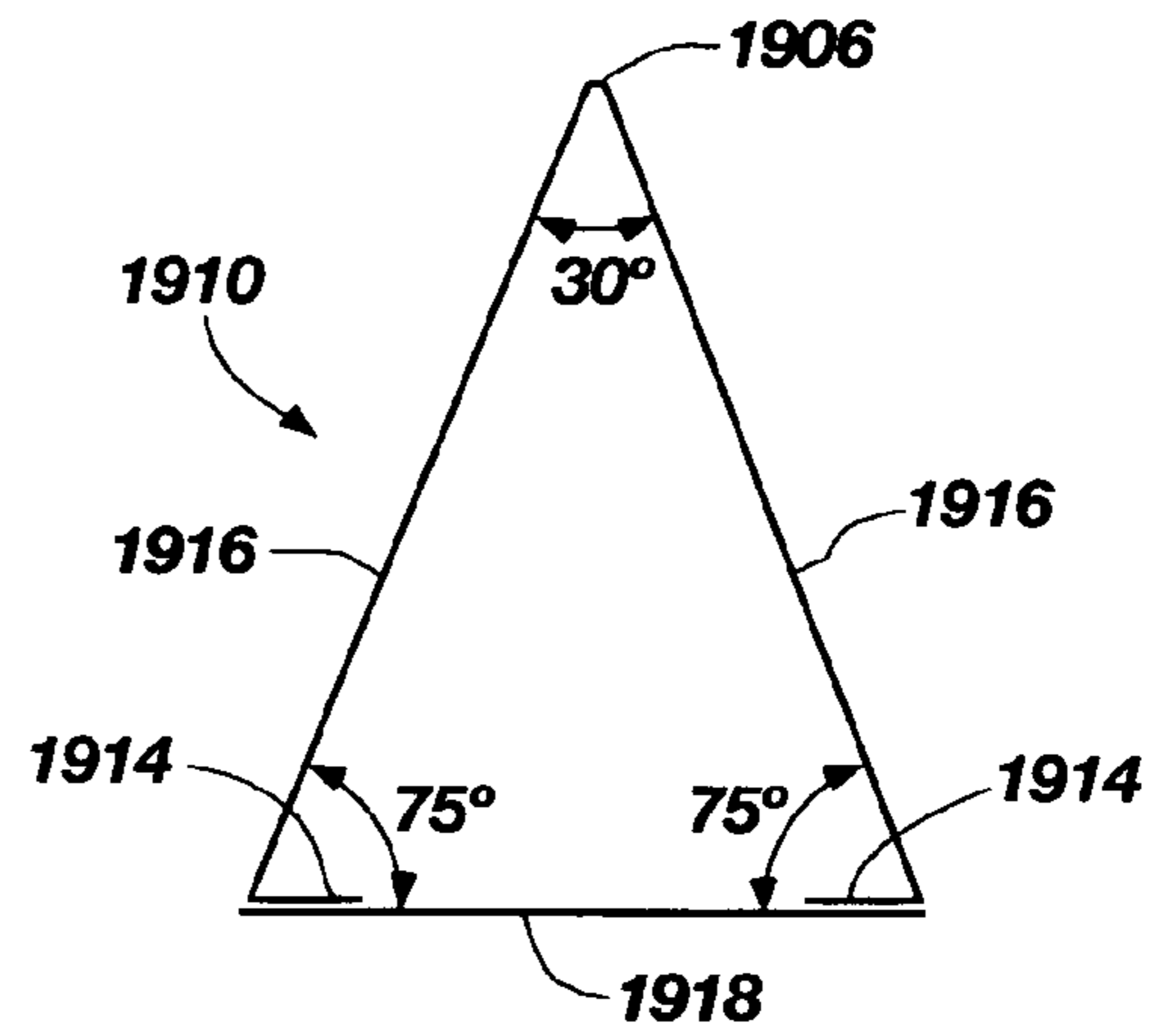

FIG. 19B

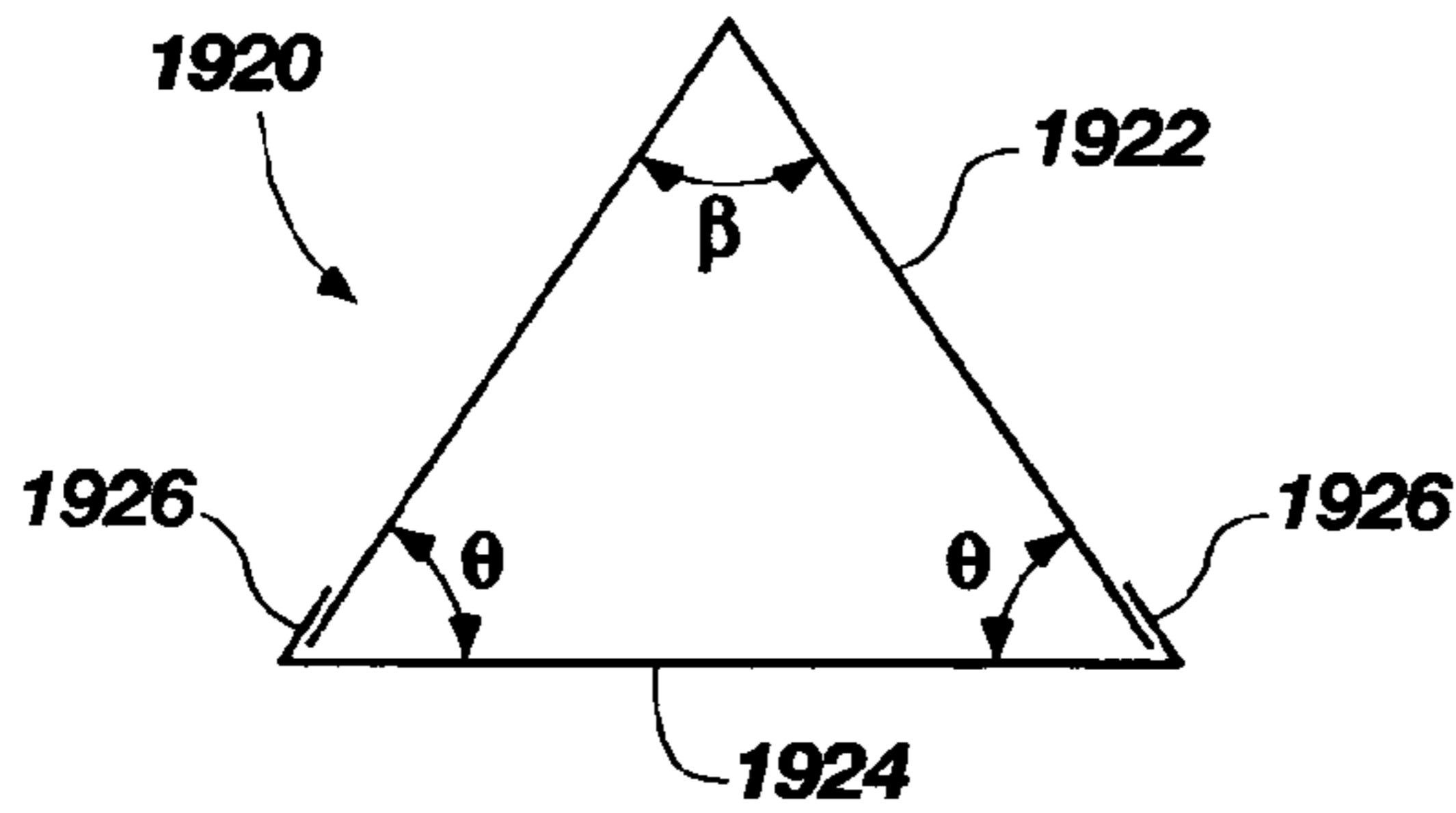

FIG. 19C

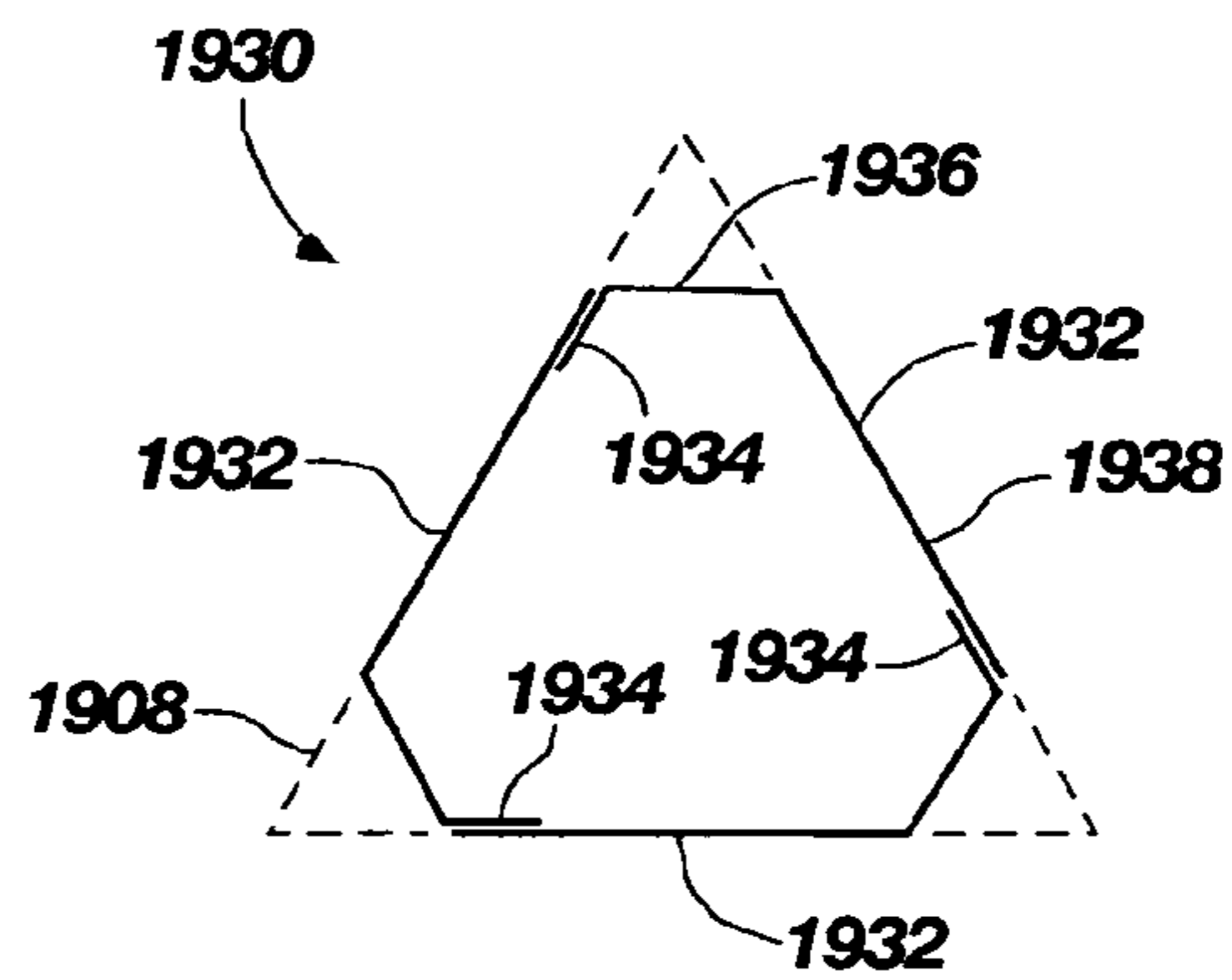

FIG. 19D

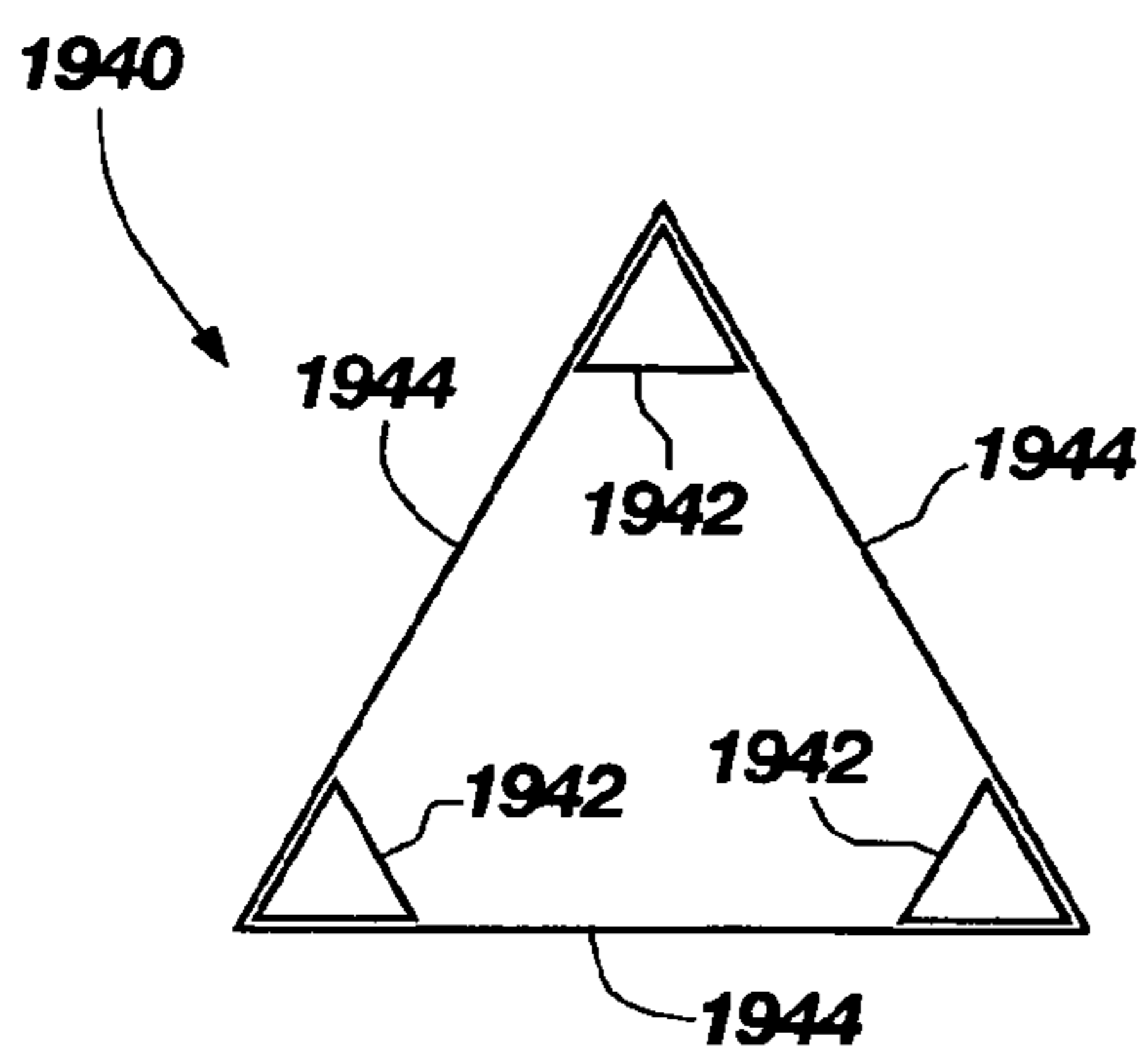

FIG. 19E

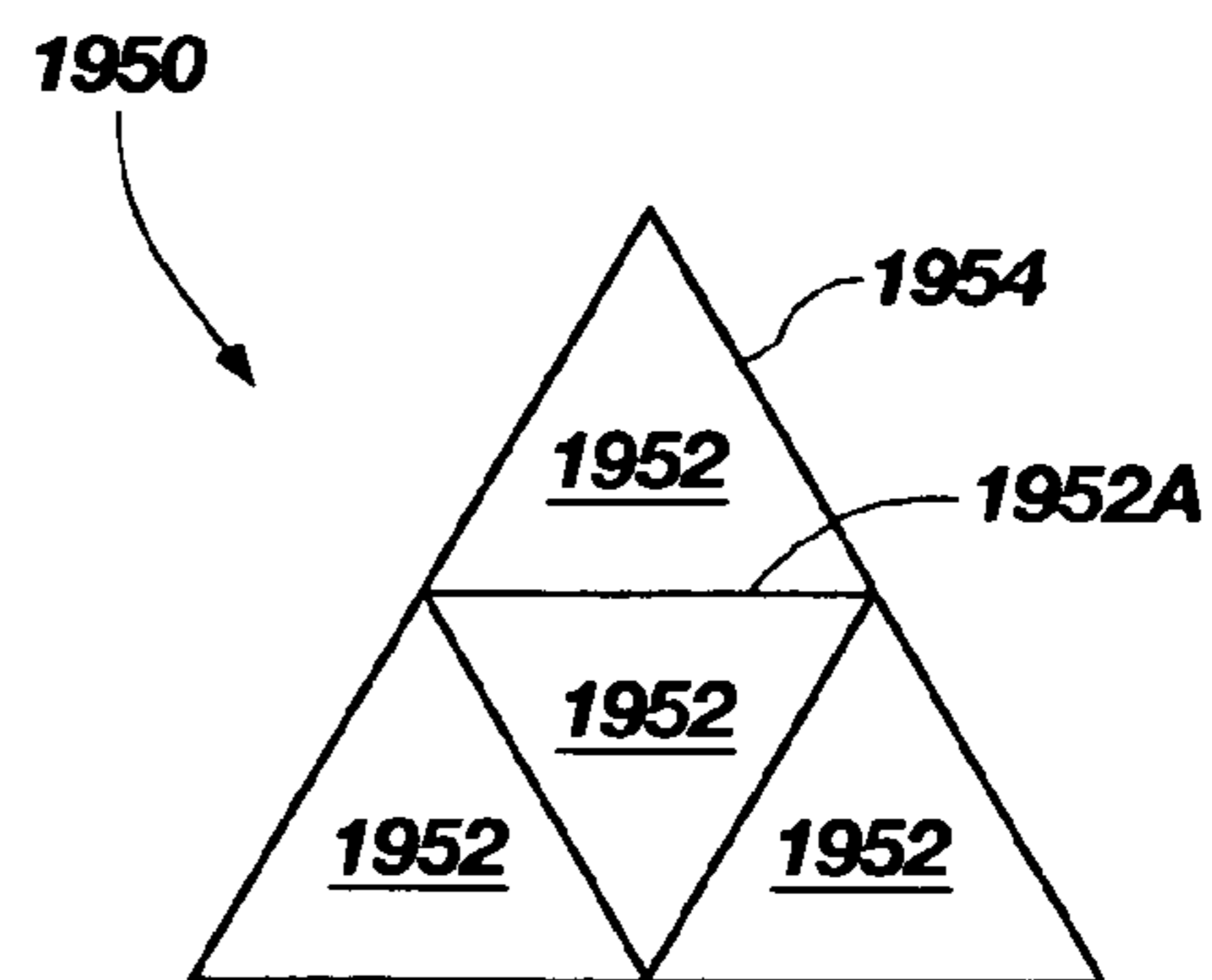

FIG. 19F

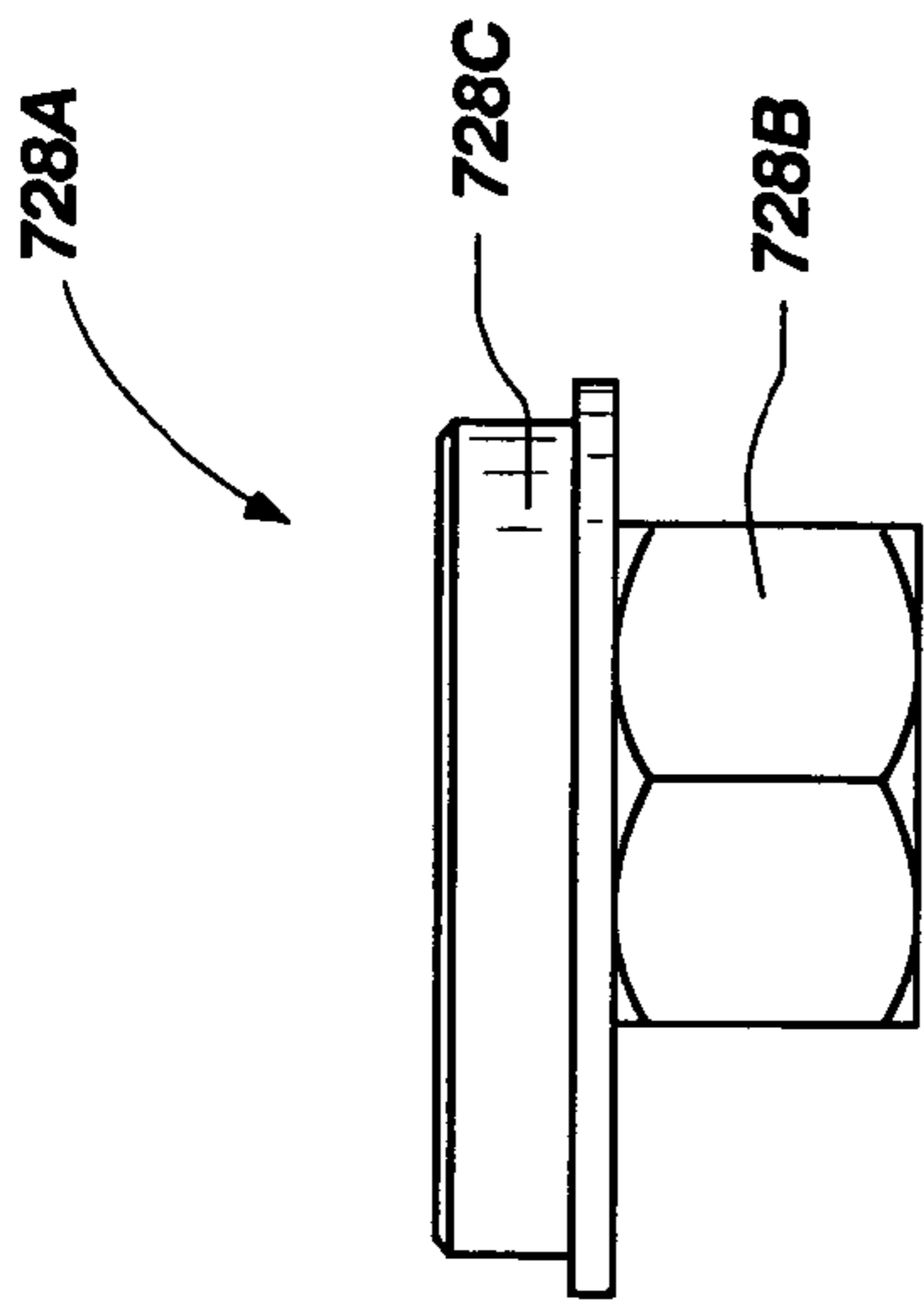

FIG. 20B

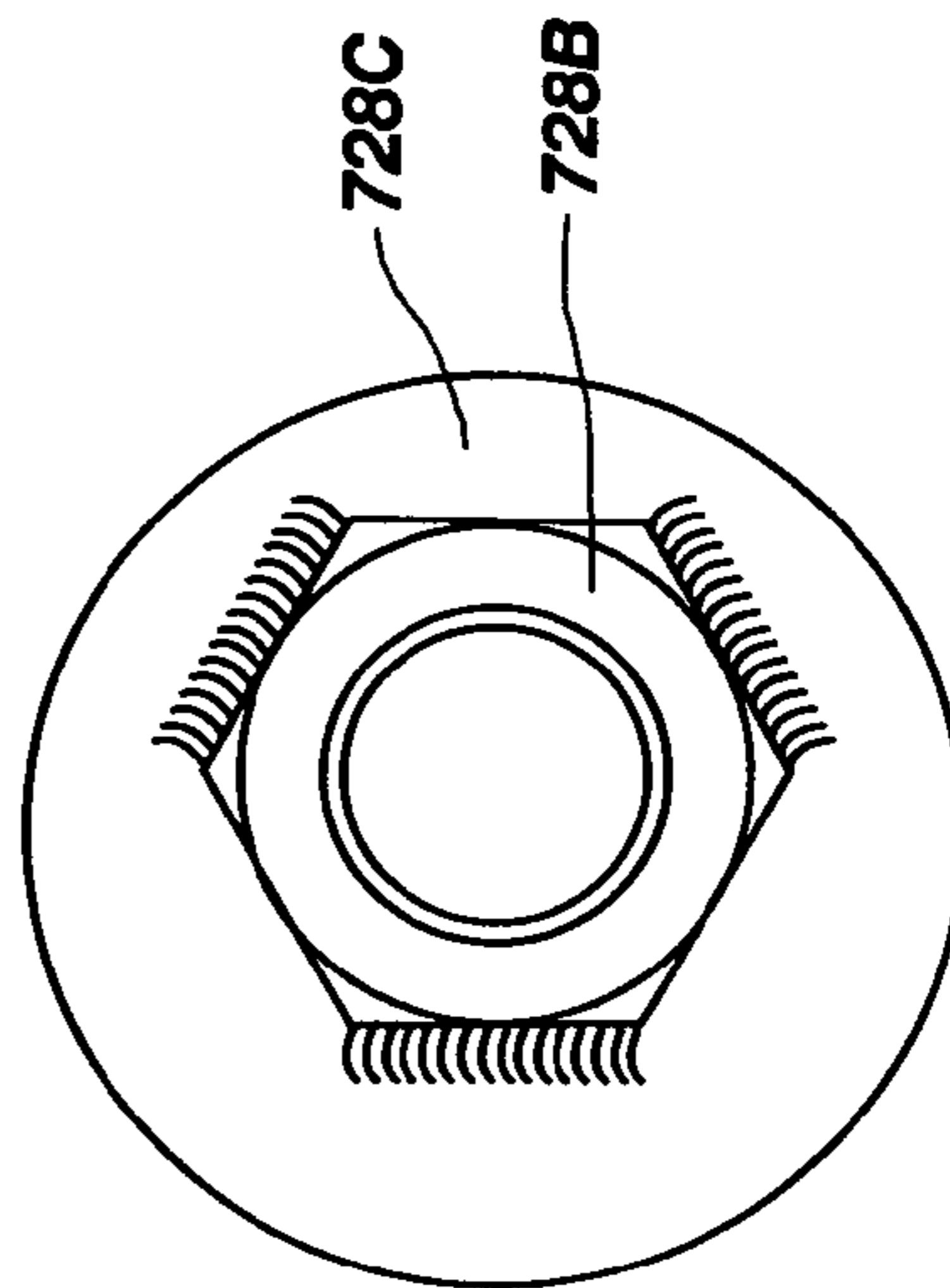

FIG. 20A

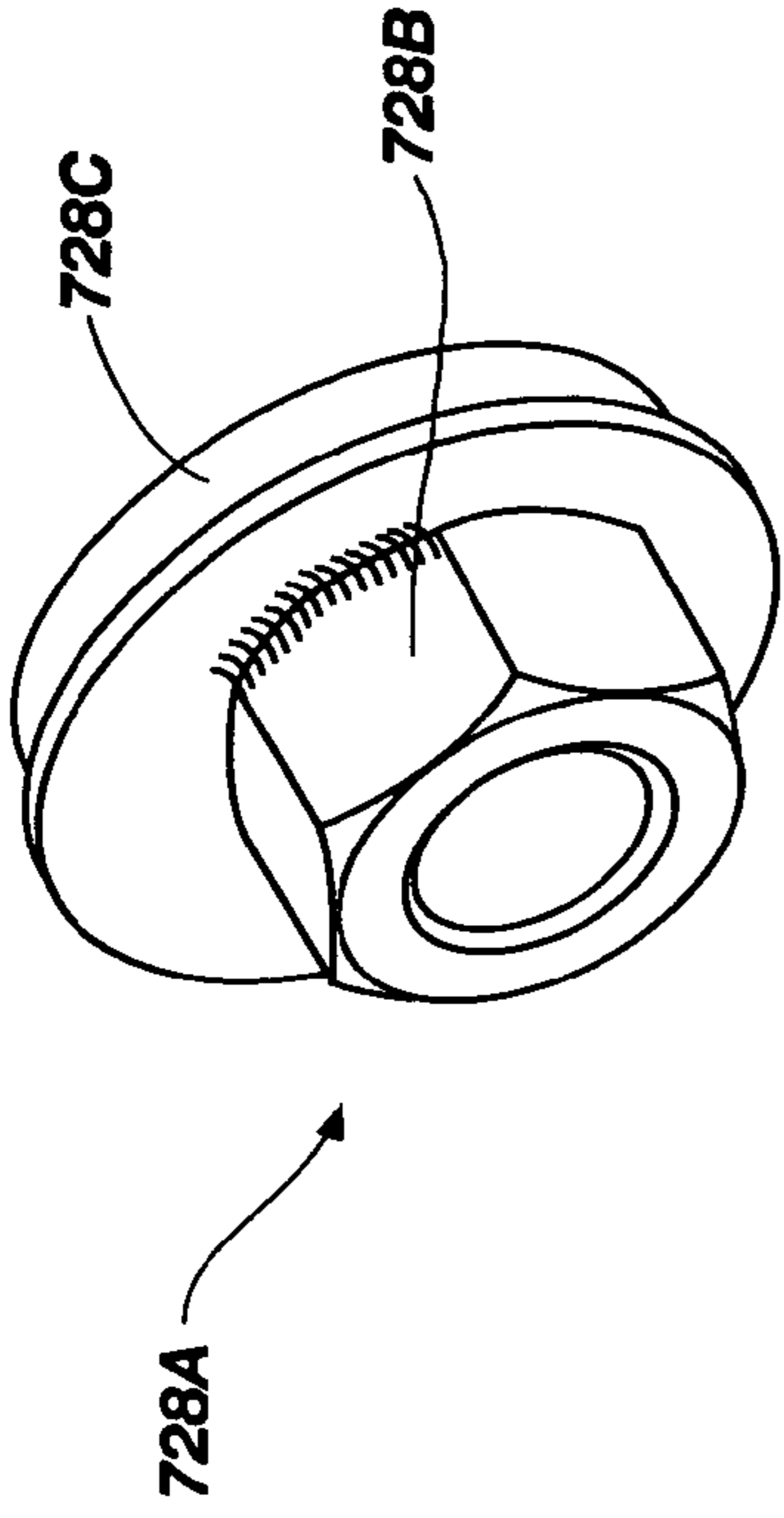

FIG. 20D

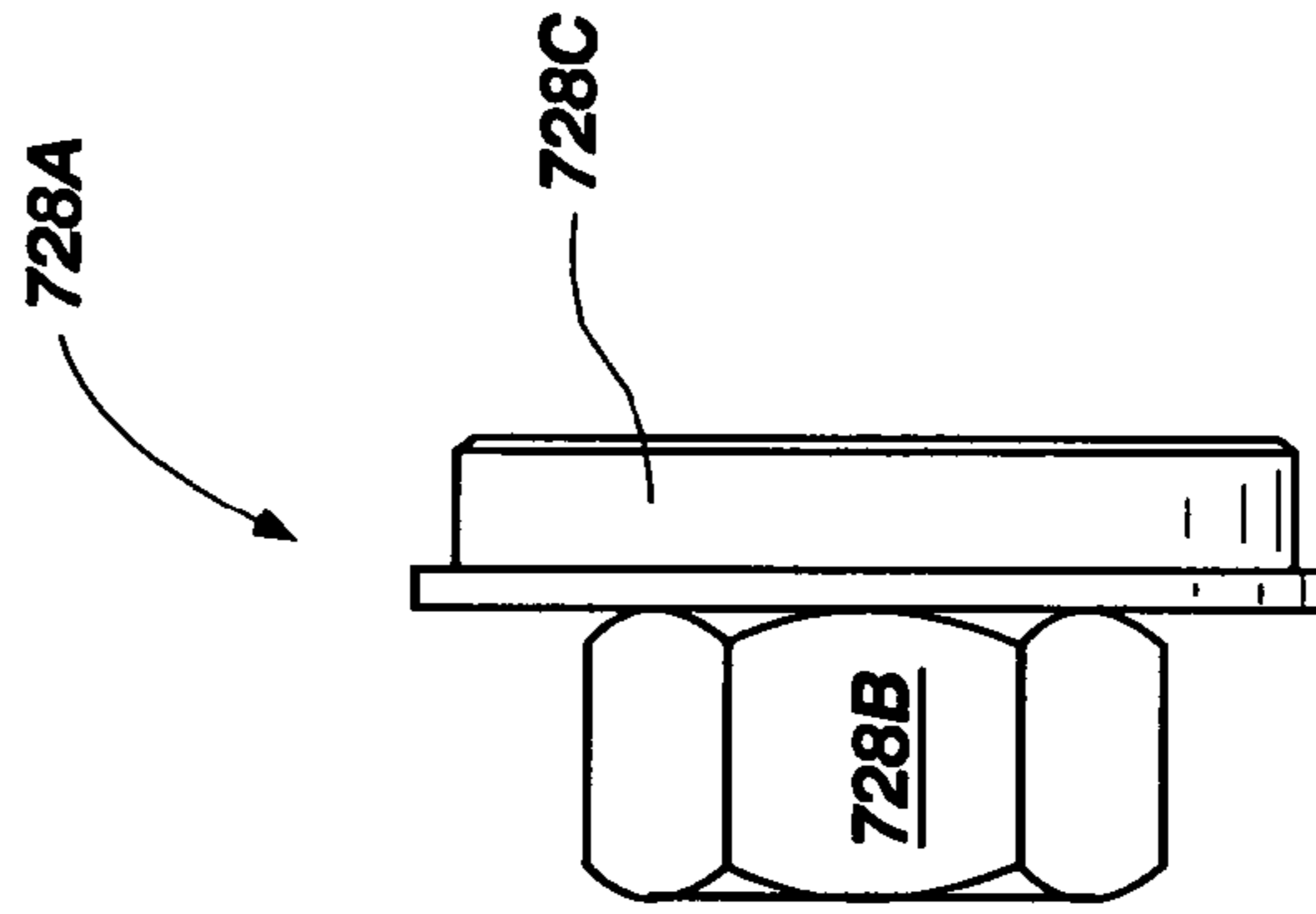

FIG. 20C

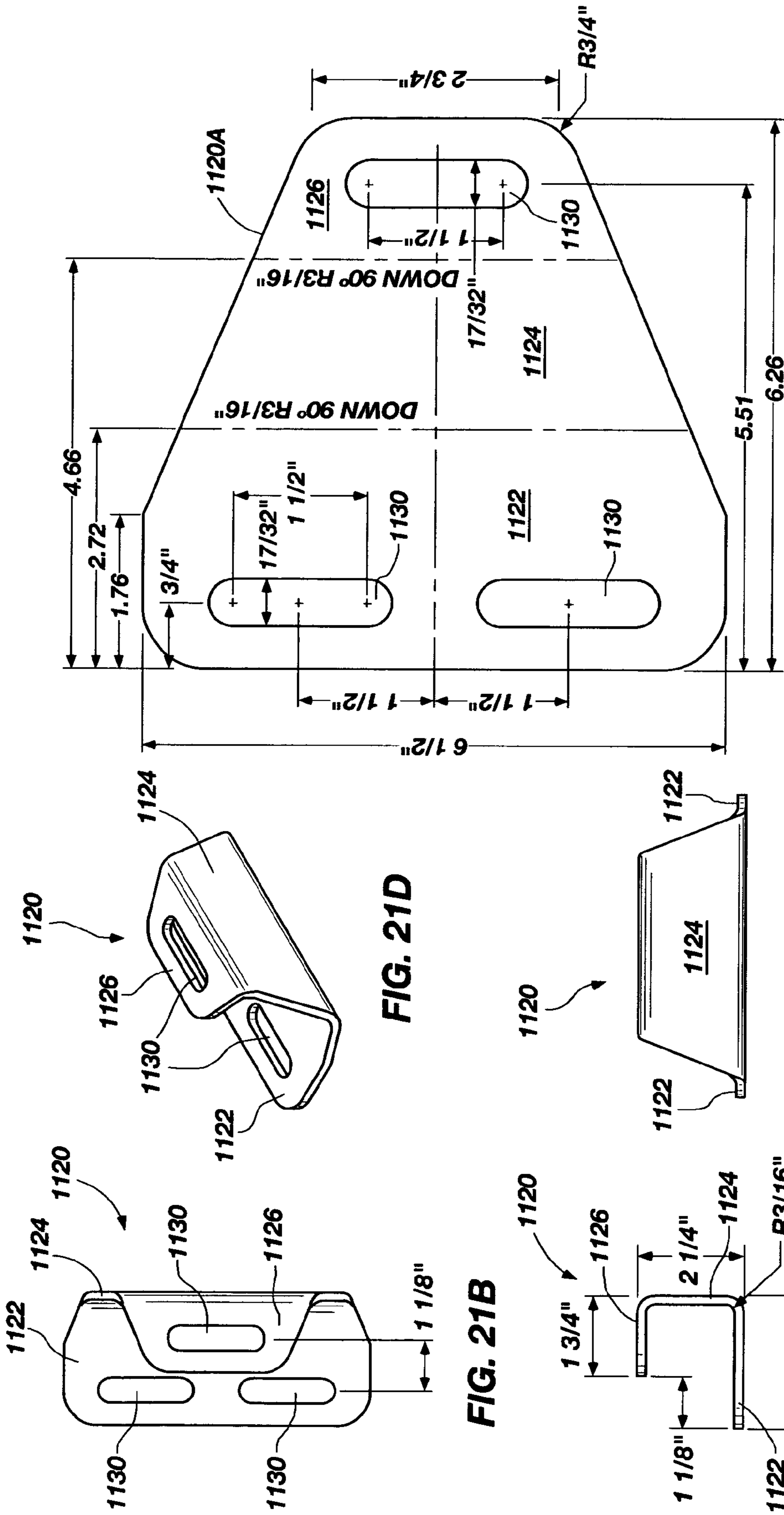

FIG. 21E

FIG. 21C

FIG. 21D

FIG. 21B

FIG. 21A

ELEVATED RAIL SYSTEM AND REACTION ASSEMBLY

CROSS-REFERENCE TO RELATED APPLICATION

This is a continuation patent application claiming benefit and priority of U.S. Utility patent application Ser. No. 12/075,619 filed on Mar. 12, 2008, titled "HOLLOW STRUCTURAL MEMBERS, A RAIL SYSTEM AND METHODS OF MANUFACTURING", issued Nov. 29, 2011 as U.S. Pat. No. 8,066,200.

BACKGROUND OF THE INVENTION

1. Field of the Invention

This invention relates generally to structural members particularly useful for railed transportation systems. More particularly, the invention relates to an elevated rail system and reaction assembly.

2. Description of Related Art

Railed transportation systems are well known in the art. Most conventional railways for transportation of people, goods and other resources rely on friction between the drive wheels and rails. Such conventional rail transportation systems may not be suitable for use on steep grades where traction may become a problem. To compensate for the lack of necessary friction, various elaborate multiple-wheeled and spring-loaded friction-based rail transportation systems have been devised, such as those described in U.S. Pat. No. 4,602,567 to Hedström, U.S. Pat. No. 5,069,141 to Ohara et al., U.S. Pat. No. 5,231,933 to DiRosa, U.S. Pat. No. 5,419,260 to Hamilton, U.S. Pat. No. 5,964,159 to Hein, U.S. Pat. No. 6,053,286 to Balmer, U.S. Pat. No. 6,666,147 to Minges and U.S. Patent Application Publication No. 2004/0168605 to Minges. However, these systems are inherently complex mechanical systems.

For applications where steep grades are the norm, railed transportation systems may rely on a toothed rack rail, usually between the running rails in a system known variously as a "cog railway", a "rack-and-pinion railway" or simply, "rack railway". Trains operated on a rack railway are generally fitted with one or more cog wheels or pinions that mesh with the rack rail for driving the train along the track. However, such rack railway systems suffered from derailments when the cog wheel slipped out of the teeth in the rail rack. Additionally, the rail rack itself was expensive to produce and maintain. Furthermore, switches for rack railways were more complex because of the rail rack.

In other approaches to driving over steep gradients, railed transportation systems may rely on other drive mechanisms such as cables and chain-driven systems to pull a car up a track, or to lower it down a track on a steep incline. Examples of conventional cable-driven, railed transportation systems include U.S. Pat. No. 3,891,062 to Geneste, U.S. Pat. No. 4,026,388 to Creissels, U.S. Pat. No. 4,534,451 to Peter, U.S. Pat. No. 4,821,845 to DeVaiaris and U.S. Pat. No. 6,739,430 to Hill. A variation on the cable-driven systems are those which utilize a chain-drive mechanism such as that disclosed in U.S. Pat. No. 1,838,204 to Wood and U.S. Pat. No. 4,627,517 to Bor. While these cable and chain-driven systems tend to be simpler than the friction-based systems for inclined applications, they do not lend themselves well to applications that include turns and changes in inclination because of the nature of cable and chain-driven drives. More specifically, it is difficult to configure a chain or cable for driving a car over

a track having turns and changes in inclination because the force exerted by a chain or cable is linear in nature.

Thermal expansion of steel and other track materials has been a limiting factor for simple track design for many years. For example, in the intermountain west, a 120° F. temperature differential may result in approximately one inch of track expansion per 100' of track. If such expansion is not accounted for through stronger reinforcements and supports, the result can be bowing or buckling of the track due to thermal expansion. For this reason, track lengths have been limited to short lengths in most conventional elevator and funicular equipment applications.

One method of dealing with track expansion is to capture the expansion between structural members. This method requires the use of larger foundations and structural members for the track supports to withstand the stresses built up between captured points of the track. This thermal expansion results in a deflection of the track between the captured points. This deflection may cause the track to bend, twist, or at worst case, buckle the track or supports, all of which are undesirable. The deflection also causes additional stresses to all connections including fasteners and connection brackets and/or weldment points requiring the strengthening of these connections. Over time with the increase in thermal cycles, the potential for premature failure of these connection or weldment locations generally increases, resulting in an undesirable failure. The design, manufacturing and installation costs for both labor and materials to compensate for this thermal expansion all increase as a result. For these reasons, the reinforcement method is not preferred as it creates considerable design challenges and increases the economic cost to the system.

Another approach to solving the thermal expansion problem in tracks relies on low-friction clamping systems. The low-friction clamping system allows the track to expand and contract while keeping the track constrained at the supports. For example, this method can utilize dissimilar materials in the clamp, or a roller and bearing assembly. This approach requires a low enough coefficient of friction to allow movement of the track while remaining constrained. A low-friction clamping system is susceptible to contamination and requires additional maintenance to ensure free movement in the track system. This method, while achieving a desired result for reducing the stresses in a long track system, is complicated and requires significant maintenance for long-term operation. For these reasons, the low-friction clamping system approach is not preferred because of the additional maintenance and expense to operate such an intricate system.

Thus, there is a need in the art for a modular track or rail system that can traverse an unlimited track length. It would be advantageous if the track were formed from a plurality of lightweight hollow structural members. It would also be advantageous to have a rail system that is not limited by inclination of the terrain over which it is constructed. It would also be advantageous to have a rail system that is virtually unlimited in curvature of the track. It would also be advantageous to have a rail system that can compensate for thermal expansion without resorting to the additional expense and maintenance of the reinforced support or low-friction clamping methods of the prior art.

SUMMARY OF THE INVENTION

An elevated rail system is disclosed. The system may include a track formed of a plurality of elongated hollow structural members joined end-to-end. The system may further include a plurality of vertical supports for selectively

elevating the track above ground. Each vertical support may further include a vertical beam secured at a first end to a concrete foundation. Each vertical support may further include dual adjustment brackets slideably engaging a second end of the vertical beam to allow for precise elevation of the track. Each vertical support may further include a pivot mechanism disposed between the track and the dual adjustment brackets configured to prevent buildup of stresses caused by thermal expansion or contraction of the track. The system may further include a reaction assembly rotationally coupled to the pivot mechanism and anchored to a concrete foundation, the reaction assembly disposed between adjacent vertical supports, ground and the track, the reaction assembly anchoring local stresses caused by the thermal expansion or contraction of the track.

Another embodiment of an elevated rail system is disclosed. The system may include a plurality of hollow triangular prism-shaped rail segments, each rail segment forming a piecewise linear segment of a track. The system may further include a plurality of vertical supports rotationally coupled to the track for selectively elevating the track above ground. Each of the vertical supports may include a vertical beam with first end secured to a concrete foundation. Each of the vertical supports may further include a vertical support bracket coupled to the track having two pivot points. Each of the vertical supports may further include a pair of adjustment brackets disposed between the vertical beam and the vertical support bracket. The adjustment brackets may each have a lower end slideably engaging a second end of the vertical beam to allow for precise elevation of the track. The adjustment brackets may each have an upper end rotationally coupled to one of the pivot points, wherein the rotational coupling of the pivot points allows the track to expand or contract along its centroid due to thermal expansion.

Yet another elevated rail system is disclosed. The system may include a plurality of rail segments, each rail segment forming a piecewise linear segment of a track. The system may further include a plurality of vertical supports rotationally coupled to the track for selectively elevating the track above ground. Each of the vertical supports may include a vertical beam with first end secured to a concrete foundation. Each of the vertical supports may further include a footing frame mounted within each of the concrete foundations for receiving a first end of the vertical beam. Each of the vertical supports may further include two eccentric bolt and washer assemblies adjustably connecting the footing frame to the first end of the vertical beam, the eccentric bolt and washer assemblies allowing for precise adjustment of vertical inclination of the vertical support.

Still another elevated rail system is disclosed. The system may include a track having arbitrary length and configured for supporting a vehicle. The system may include a plurality of vertical supports configured for selectively elevating the track above concrete foundations formed in ground. Each of the plurality of vertical supports may further include a vertical support bracket attached to the track including two pivot points. Each of the plurality of vertical supports may further include a vertical beam oriented vertically between the track and one of the concrete foundations. Each of the plurality of vertical supports may further include two adjustment brackets, each rotationally connected to one of the two pivot points and slidably attached to the vertical beam. Each of the two adjustment brackets may further include a threaded bolt disposed between the adjustment bracket and the vertical beam, the threaded bolt providing micro-adjustment of height of the track above the one concrete foundation.

Additional features and advantages of the invention will be set forth in the description which follows, and in part will be apparent from the description, or may be learned by the practice of the present invention.

BRIEF DESCRIPTION OF THE DRAWINGS

To further clarify the advantages and features of the present invention, a more particular description of the invention will be rendered by reference to specific embodiments thereof that are illustrated in the appended drawings. It will be appreciated that these drawings depict only typical embodiments of the invention and are therefore not to be considered limiting of the scope of the invention. The invention will be described and explained with additional specificity and detail through the use of the accompanying drawings.

FIG. 1 is a flowchart of an embodiment of a method of forming a hollow triangular prism-shaped structural member, according to the present invention.

FIG. 2A is a top view of an embodiment of a rectangular main panel used to form a triangular cross-sectioned member according to the present invention.

FIG. 2B is a side view of a hollow triangular prism-shaped structural member formed from the rectangular main panel of FIG. 2A, according to the present invention.

FIG. 2C is a top view of the hollow triangular prism-shaped structural member shown in FIG. 2B.

FIG. 2D is an end view of the hollow triangular prism-shaped structural member shown in FIG. 2B.

FIG. 2E is a detailed view of a portion of the rectangular main panel as indicated on FIG. 2A.

FIG. 2F is a detailed view of the centerline or first fold of the hollow triangular prism-shaped structural member shown in FIG. 2B.

FIG. 2G is another detailed view of a portion of the rectangular main panel as indicated on FIG. 2A.

FIG. 2H is a perspective view of a hollow triangular prism-shaped structural member formed from the rectangular main panel of FIG. 2A, according to the present invention.

FIGS. 3A-C illustrate top, detailed and perspective views of an embodiment of an elongated rectangular base panel according to the present invention.

FIGS. 4A-D illustrate perspective, side, bottom and end views of an embodiment of a track according to the present invention.

FIGS. 5A-D illustrate perspective, front, top and end views of an embodiment of a coupling bar according to the present invention.

FIG. 5E illustrates a top view of a coupling bar form from which the coupling bar shown in FIGS. 5A-D may be formed, according to an embodiment of the present invention.

FIG. 6A illustrates a portion of a track elevated from the ground by vertical supports and a reaction assembly according to an embodiment of the present invention.

FIG. 6B illustrates an angled perspective view of the elevated rail system shown in FIG. 6A.

FIG. 6C illustrates a detailed portion of the lateral support adjustment assembly circled in FIG. 6B.

FIGS. 7A-D illustrate front, top, side and perspective views of an embodiment of a vertical support according to the present invention.

FIG. 7E illustrates a perspective transparent view of a vertical support mounted in a concrete form.

FIGS. 8A-D illustrate front, side, top and perspective views of an embodiment of a vertical support bracket according to the present invention.

FIGS. 9A-C illustrate front, cross-section and perspective views of the attachment of a vertical support bracket to adjacent rail segments of a track according to an embodiment of the present invention.

FIG. 10 is an embodiment of a curved rail segment according to the present invention.

FIGS. 11A-C illustrate side, end and detailed top views of a track with a rack according to embodiments of the present invention.

FIGS. 12A-D illustrate front, top, side and detailed views of an embodiment of a rack segment, according to the present invention.

FIGS. 13-15 illustrate various perspective views of an embodiment of a rail system 1300, according to the present invention.

FIGS. 16A-C illustrate exemplary topologies of paths which may be traversed by a rail system, according to the present invention.

FIGS. 17A-C illustrate another embodiment of a triangular prism-shaped rail segment formed from a bottom plate and a top rib, according to the present invention.

FIGS. 18A-B illustrate yet another embodiment of a triangular prism-shaped rail segment formed of a single sheet of material, according to the present invention.

FIGS. 19A-F illustrate various alternative embodiments of structural member cross-sections which may be employed for rail systems, towers and the like, consistent with the principles of the present invention.

FIGS. 20A-D are front, top, side and perspective drawings of an eccentric bolt and washer assembly, according to the present invention.

FIGS. 21A-E illustrate front, top, side and perspective views of rack bracket and a flat template from which a rack bracket may be patterned and formed according to an embodiment of the present invention.

DETAILED DESCRIPTION OF THE INVENTION

Reference will now be made to figures of embodiments of the present invention wherein like structures will be provided with like reference designations. It is understood that the drawings are diagrammatic and schematic representations of exemplary embodiments of the present invention and are neither limiting of the present invention nor are they necessarily drawn or shown to scale.

Embodiments of the present invention are directed to a novel hollow triangular prism-shaped structural member and methods of forming same. This triangular cross-sectioned member is particularly useful as an assembly that may form a track upon which a car may ride. However, it will be evident that there are many other applications for such a light weight structural member, for example a radio tower.

FIG. 1 is a flowchart of an embodiment of a method 100 of forming a hollow triangular prism-shaped structural member, according to the present invention. Method 100 may include forming 102 a rectangular main panel having two long edges and two short edges and a first fold line bisecting the main panel along a lengthwise centerline between and parallel to the two long edges, the main panel further including second and third fold lines each disposed parallel to and a predetermined distance from each of the two long edges. Method 100 may further include bending 104 the main panel generally along the first fold line to form an inside angle of approximately 60° to form a V-shaped cross-section. Method 100 may further include bending 106 the main panel generally along the second fold line to form a first lip having an inside angle of approximately 60°, the first lip extending toward the

third fold line and partially enclosing space inside the V-shaped cross-section. Method 100 may further include bending 108 the main panel generally along the third fold line to form a second lip having an inside angle of approximately 60°, the second lip extending from the third fold line toward and generally parallel to the first lip and further partially enclosing the space inside the V-shaped cross-section. Method 100 may further include forming 110 an elongated rectangular base panel. Method 100 may further include connecting 112 the elongated rectangular base panel to the first and second lips of the rectangular main panel to form a generally closed triangular cross-sectioned structural member or hollow triangular prism.

According to another embodiment of method 100, forming 102 the rectangular main panel may further include forming cut-outs in the rectangular main panel between the fold lines. The cut-outs reduce the weight of the hollow triangular prism-shaped structural member and also the cost associated with the material from which it is formed, generally steel. Any suitable material may be used to form the hollow triangular prism-shaped structural member, for example and not by way of limitation, galvanized steel, stainless steel, carbon steel, aluminum, fiberglass and composite structures. The bending procedures 104, 106, 108 of method 100 may be performed on the metal materials described, either during forging or during cold stamping, bending and roll forming processes known to those of skill in the art. It will be understood that the bending procedures 104, 106, 108 of method 100 may also be performed in situ around a form during construction where composite materials such as fiberglass and graphite are used.

According to another embodiment of method 100, forming 102 the rectangular main panel may further include forming mounting holes in the rectangular main panel. Mounting holes formed along the lips may be used with mating holes formed on the elongated rectangular base panel for securing the two panels together using nuts and bolts. Mounting holes formed closer to the centerline of the rectangular main panel may be used for mounting a rack used to propel a vehicle along a track formed of the hollow triangular prism-shaped structural member. Mounting holes may be used to attach radio antennas in a radio tower application for a particular assembly of the hollow triangular prism-shaped structural members. According to various embodiments, the mounting holes may be formed in rows parallel to the fold lines. For example, a row of mounting holes may be placed on each of the lips of the rectangular main panel for use in attaching the elongated rectangular base panel. According to another exemplary embodiment, rows of mounting holes may be placed a specified distance from the center line of the rectangular main panel for mounting a rack for use in a track application.

According to another embodiment of method 100, forming 110 the elongated rectangular base panel may further include forming cut-outs in the elongated rectangular base panel. This cut-out feature may be used to reduce weight and allow wind and water to pass through the hollow triangular prism-shaped structural members and yet retain necessary rigidity. The cut-outs may take any suitable shape or pattern. Furthermore, the cut-outs may be drilled, laser cut, stamped, or formed using any other suitable method of forming such cut-outs known to those skilled in the art.

According to another embodiment of method 100, connecting 112 the elongated rectangular base panel to the first and second lips of the rectangular main panel may be accomplished by bolting the panels together using mounting holes formed in each panel. According to an alternative embodiment of method 100, connecting 112 the elongated rectangu-

lar base panel to the first and second lips of the rectangular main panel may be achieved by welding the panels together. It will be understood that other methods of attaching the lips of the rectangular main panel to the elongated base panel will be readily apparent to one of ordinary skill in the art and are considered to be within the scope of the present invention.

Method 100 may be used to form a rail system by further joining end-to-end a plurality of the hollow triangular prism-shaped structural members formed according to method 100 described above. The rail system application is not the only presently perceived application for the hollow triangular prism-shaped structural members formed by method 100. Method 100 may be used to form a radio tower by joining end-to-end a plurality of the hollow triangular prism-shaped structural members formed according to method 100.

FIG. 2A illustrates a top view of an embodiment of a rectangular main panel 200 used to form a hollow triangular prism-shaped structural member (see 250 in FIGS. 2B, 2C, 2D and 2H) according to the present invention. Rectangular main panel 200 includes two long edges 202 and two short edges 204. Rectangular main panel 200 may be formed to any suitable length, l. In presently preferred embodiments, rectangular main panel 200 may be formed to predefined lengths, l, of approximately 5' and approximately 10' lengths as measured along long edges 202. Rectangular main panel 200 includes a first fold line 206 coinciding with a centerline that bisects the main panel 200 lengthwise. Rectangular main panel 200 further includes second 208 and third fold lines 210. As shown in FIG. 2A, all of the fold lines 206, 208, 210 are parallel to the long edges 202. Once folded, the fold lines 206, 208, 210 form the vertices (212 as shown in FIGS. 2D and 2H) of the triangular prism-shaped structural member (not shown in FIG. 2A, but see 250 in FIGS. 2B, 2C, 2D and 2H).

Once folded, rectangular main panel 200 forms two sides 216, two lips 218 along a third side and two open ends 222 of a hollow triangular prism-shaped structural member (250 as shown in FIG. 2H) with a gap 226 along the third side. Rectangular main panel 200 may optionally include a plurality of cut-outs 214 generally formed in the two sides 216. Cut-outs 214 may be of any suitable shape including the generally rounded alternating triangular shape illustrated in FIGS. 2A-C, 2E and 2H. FIG. 2E illustrates a portion of FIG. 2A in detail. FIG. 2E shows cut-outs 214 and rows of mounting holes 220. The dimensions shown in FIG. 2E are exemplary of a particular embodiment and are not meant to be limiting. FIG. 2G is another detailed view of a portion of the rectangular main panel 200 as indicated on FIG. 2A. As shown in FIG. 2G, rectangular main panel 200 may include an orientation notch 224 used during assembly of a plurality of hollow triangular prism-shaped structural members 250.

FIG. 2B is a side view of a hollow triangular prism-shaped structural member 250 formed from the rectangular main panel of FIG. 2A. FIG. 2B illustrates cut-outs 214 along one side 216. FIG. 2B also illustrates rows (two rows shown in FIG. 2B and six rows shown in FIG. 2A) of mounting holes 220 along one side 216 that may be used for mounting racks (not shown in FIGS. 2A-H) or for other equipment (also not shown for clarity). Structural member 250 may have any suitable height, h. According to a particular embodiment, height, h, may be approximately 17.6".

FIG. 2C is a top view of the hollow triangular prism-shaped structural member 250 shown in FIG. 2B. FIG. 2C illustrates the rows of mounting holes 220, fold lines 206, 208 and 210, short edges 204 and cut-outs 214. In a rail system application (explained in greater detail below) for the hollow triangular

prism-shaped structural member 250, a wheel of a car (not shown) may rest on the crown (or vertex 212) formed by fold line 206.

FIG. 2D is an end view of the hollow triangular prism-shaped structural member 250 shown in FIG. 2B. FIG. 2D illustrates vertices 212 of an equilateral triangle cross-section of the hollow triangular prism-shaped structural member 250 having three sides 216. FIG. 2D also illustrates gap 226 between lips 218. Sides 216 may be of any suitable width. According to the illustrated embodiment, sides 216 have widths of approximately 20". It will be understood that the widths of sides 216 may be of any suitable dimension depending on the application. The circled detail of FIG. 2D is shown in FIG. 2F. More particularly, FIG. 2F is a detailed view of the centerline or first fold 206 of the hollow triangular prism-shaped structural member 250 shown in FIG. 2B. A vertex 212 is shown at centerline of first fold 206 between sides 216.

FIG. 2H is a perspective view of a hollow triangular prism-shaped structural member 250 formed from the rectangular main panel 200 shown in FIG. 2A, according to the present invention. FIG. 2H illustrates rows of mounting holes 220, cut-outs 214, open ends 222 and gap 226 between lips 218. As noted above, the cut-outs 214 are optional. The particular dimensions of features of main panel 200 shown in FIGS. 2A-B and 2D-G are merely exemplary of a presently preferred embodiment, i.e., a rail system as further explained below. It will be understood that the dimensions of main panel 200 may be suitably scaled up or down or changed depending on the particular application.

Referring now to FIGS. 3A-C, an embodiment of an elongated rectangular base panel 300 is shown according to the present invention. The base panel 300 is configured to mate with structural member 250 to enclose gap 226. More specifically, FIG. 3A illustrates a top view of the base panel 300, with length, l, a plurality of cut-outs 314, and two rows of mounting holes 320. FIG. 3B is a detailed view of the circled portion of the base panel 300 shown in FIG. 3A. The optional cut-outs 314, like cut-outs 214 (FIGS. 2A-C) reduce the weight (and cost) of an assembly (not shown) made with a plurality of structural members 250 and base panels 300. Cut-outs 314 also allow wind to pass through and water to escape from such assemblies, as may be desirable depending on the application. While the cut-outs 314 are shown as generally rounded rectangular openings, they may take any suitable shape or pattern as long as the strength of the base panel 300 is maintained. The width, m, of base panel 300 and the placement of mounting holes 320 may be any suitable dimension and location, respectively, in order to be mated with structural member 250 at mounting holes 220 along the lips 218. It will be understood that the dimensions of various features of base panel 300 shown in FIG. 3B are merely exemplary and may be scaled up or down or changed depending on the desired size of the end application. FIG. 3C is a perspective view of base panel 300 showing mounting holes 320 and optional cut-outs 314.

Referring now to FIGS. 4A-D, an embodiment of a track 400 is shown according to the present invention. More particularly, FIGS. 4A-D illustrate perspective, side, bottom and end views, respectively, of track 400. As shown in FIG. 4A, track 400 may include a plurality of rail segments 402 (two shown) assembled end-to-end using coupling bars 500 attached within respective mating vertices 412 of the triangular prism-shaped rail segments 402. Each rail segment 402 is comprised of a structural member 250 attached to a base panel 300. FIG. 4B illustrates a side view of track 400 comprised of two adjacent hollow triangular prism-shaped structural members 250 assembled at joint 404, and shown with

optional cut-outs 214. FIG. 4C illustrates elongated rectangular base panel 300 having optional cut-outs 314 as assembled to structural member 250. FIGS. 4A-B and D also illustrate a centroid 440 of the track 400 as assembled. Centroid 440 is shown as a dotted line in FIGS. 4A-B and as a point in the end view of FIG. 4D. FIG. 4D further illustrates the attachment of structural member 250 to base panel 300 using nuts and bolts 428 through respective mounting holes 220 in lips 218 and mounting holes 320 in base panel 300. It will be understood that alternative means for attaching structural member 250 to base panel 300 will be readily known to those skilled in the art, for example and not by way of limitation, welding, adhesives, rivets and the like. Such alternative means are considered to be within the scope of the present invention.

It will be readily apparent from FIG. 4D that the cross-section of track 400 formed of a plurality of individual rail segments 402 is generally of the shape of an equilateral triangle. This triangular cross-section provides significant structural advantages (e.g., strength to weight ratio, torsional rigidity, etc.) over other conventional structures, especially in the application of a track for a rail system. The equilateral triangle formed by the cross-section of structural member 250 includes a gap 226 (FIG. 2D) between lips 218 that is effectively closed by the attachment of base panel 300.

Referring now to FIGS. 5A-E, an embodiment of a coupling bar 500 and an embodiment of a coupling bar form 560 are shown according to the present invention. More specifically, FIGS. 5A-D are perspective, front, top and end views of an embodiment of a coupling bar 500. FIG. 5E is a top view of a coupling bar form 560 from which a coupling bar 500 may be formed by bending at the center line 530 to fold wings 532 to an angle of about 60° as shown in FIG. 5D. Each wing 532 may be configured with a plurality (six shown) of optional mounting holes 520. The mounting holes 520 are used to bolt the coupling bar to adjacent vertices 412 (FIG. 4A) of adjacent rail segments 402 (FIG. 4A). As best seen in FIGS. 4A-C, each end of the coupling bar 500 is effectively tapered by the introduction of cut-outs 514 (FIGS. 5A-B and E) between wings 532. The tapers in the ends of each coupling bar 500 simplify the assembly of adjacent rail segments 402 (FIG. 4A) by making it easier to insert pre-assembled coupling bars 500 in one rail segment 402 into the adjacent rail segment 402. Another feature that may be incorporated into a coupling bar 500 is a second bend line (not shown) at a midsection of the coupling bar 500 to facilitate the angle of bend or direction change at a particular junction or joint 404 in the track 400. The second bend line facilitates a better fit and quicker construction of a track 400.

While the attachment of adjacent rail segments 402 is shown with coupling bars 500 and nuts and bolts 428, it will be understood that other means of attachment and configurations of coupling bars 500 are contemplated to be within the scope of the present invention. For example and not by way of limitation, rather than using the coupling bars 500 described, six rectangular bars (not shown) with mounting holes placed two to a vertex 412 may be used instead. However, the coupling bars 500 are presently preferred over such rectangular bars because they provide a stronger joint between adjacent rail segments 402.

An especially useful feature of the rail system disclosed herein is its capacity for dealing with the complications of material thermal expansion over a long length of track. The term "thermal expansion" as used herein contemplates both expansion and contraction of a particular material due to temperature fluctuations. Embodiments of the inventive system of the present invention employ a simple pivot mecha-

nism incorporated within a reaction assembly 690 (FIG. 6A) used to support the track 400. Each reaction frame 660 includes mounting points 606 (FIGS. 6A and 6C in detail) at both ends of the reaction frame 660. More specifically, there are mounting points 606 located in the lateral support brackets 650 that connect the reaction frames 660 to concrete foundations 604. There are also pivot points 806 in the vertical support brackets 800 that connect the reaction frames 660 to the track 400. This allows the thermal expansion of the track 400 to go out one or both directions (dependant on the location of reaction assembly 690) along the track 400. This feature of the inventive rail system eliminates stresses from being built up in the system due to the effects of thermal expansion. Using the novel reaction assemblies 690 and pivot points 806 results in only a slight difference in the height and length of the track 400 along its length, which may easily be compensated for during the system design.

This feature also frees the designer to concentrate on compensating for the forces applied to the reaction assembly 690 resulting from the steepness (inclination) of the track 400 and the loads applied (car or vehicle on the track) from driving or braking forces. The weight of the vehicle (not shown) and track 400 are generally supported in the vertical supports 700. The forces from the overturning loads from the vehicle, passenger weight and wind are also simply applied to the vertical supports 700 in conjunction with the reaction assemblies 690. Additionally, the novel rail system with its ability to perform curves allows for additional reaction assemblies 690 to be placed in a long track alignment, thereby trapping the thermal expansion in a curve and allowing the stresses to neutralize into the curve utilizing the pivot points 806 with little impact on the design of the concrete foundations 604 or structural support members such as the vertical support 700 and reaction assembly 690.

While the reaction assembly 690 illustrated in FIG. 6A is a presently preferred means for compensating for thermal expansion, other suitable approaches may also be employed consistent with the teachings of the present invention. For example, thermal expansion may be captured between vertical supports according to one embodiment of the present invention. According to another embodiment of the present invention, thermal expansion may be controlled by selective use of slip connections that allow the track to expand and contract with temperature fluctuations.

Referring now to FIGS. 6A-C, various views of an elevated rail system 600 are shown, according to embodiments of the present invention. More particularly, FIG. 6A illustrates a portion of a track 400 elevated from the ground 602 by vertical supports 700 and a reaction assembly shown generally at arrows 690. The reaction assembly 690 may include four reaction frames 660 (see, FIG. 6B). As shown particularly in FIGS. 6A-B, the vertical supports 700 and reaction assembly 690 may be supported in the ground 602 by concrete foundations 604. As best shown in FIG. 6A, each vertical support 700 may be attached to the track 400 with a vertical support bracket 800. Each reaction frame 660 (there are four shown in FIG. 6B) may also be attached to the track 400 at vertical support brackets 800. Each reaction frame 660 may also be attached to a concrete foundation 604 through a lateral support bracket 650. As further shown in FIG. 6A, each vertical support 700 may be attached to a concrete foundation 604 by a footing frame 738 embedded (not shown, but see FIG. 7E) in the foundation 604.

FIG. 6B illustrates an angled perspective view of the elevated rail system 600 shown in FIG. 6A. FIG. 6B illustrates the four reaction frames 660 used to react to lateral forces applied to the track 400. FIG. 6C illustrates a detailed portion

of the lateral support adjustment assembly **680** circled in FIG. **6B**. Various nuts, bolts, washers and brackets shown generally at **680** may be used to secure reaction frame **660** to vertical support bracket **800** and allow for adjustment in length of the reaction frame **660**. Such arrangements of nuts, bolts, washers and brackets are well known to those of skill in the art and are further explained in greater detail with regard to FIG. **7D** below, where a similar adjustment assembly **780** is shown.

It will be appreciated that selected use of vertical supports **700** and reaction frames **660** allows a track **400** to be suspended above ground **602** in virtually any configuration over any ground surface with any incline to form arbitrary lengths of an elevated rail system **600** according to the present invention.

Referring now to FIGS. **7A-E**, aspects and features of vertical supports **700** are shown in greater detail according to the present invention. More particularly, FIGS. **7A-D** illustrate front, top, side and perspective views of an embodiment of a vertical support **700** according to the present invention. FIG. **7E** illustrates a perspective transparent view of a vertical support **700** mounted in a concrete form **604** underneath a ground **602** surface. As shown in FIG. **7A**, vertical beam **702** may be configured with any suitable length. Vertical beam **702** may optionally include cut-outs **714** to reduce weight and wind resistance. Vertical beam **702** may be configured to accept adjustment brackets **704** (two shown in FIG. **7A**). Vertical beam **702** may also be configured with nuts, bolts and washers **740** for slidably securing adjustment brackets **704** to vertical beam **702**. Vertical beam **702** may also be configured with nuts, bolts and washers **728** for mounting to a footing frame **738** (FIG. **7E**). As shown in FIG. **7E**, footing frame **738** may be a reinforced steel framework for embedding in a concrete form **604** placed underneath or at ground **602** level.

FIGS. **20A-D** are front, top, side and perspective drawings of an eccentric bolt and washer assembly **728A** shown generally at **728** in FIG. **7C**. As shown in FIGS. **20A-D**, the eccentric bolt and washer assembly **728A** may be formed by welding a hollow hex nut **728B** to a bushing **728C**. The bushing **728C** is configured to fit within large mounting hole **744** (FIG. **7B**) and to be held in place with a bolt shown generally at **728** in FIG. **7C**. The eccentric bolt and washer assembly **728A** is used to adjust the vertical support **700** to plumb or align the vertical support **700** to the correct position under the track **400**. This adjustment compensates for any misalignment in the footing frame **738** embedded in a concrete foundation **604** that may not have been plumb or precisely aligned after pouring of the concrete. Alternatively, the eccentric bolt and washer assembly **728A** can be used to adjust the vertical support **700** in a second axis (not shown) perpendicular to centroid **440**. The adjustment in this second axis is for correcting alignment to track connections at joints **404**, more specifically to compensate for any misalignment in the concrete foundation **604** not being perpendicular to the centroid **440** or point of tangency at a curve. Both of these adjustments allow the installer of such an elevated rail system **600** to compensate for flaws in the alignment of concrete foundations **604** after curing or to perform final alignment of the track **400** having any flaws (unintended deviations from designed centroid **440**) along the length of the track. Both of these adjustments may be used independently or concurrently according to embodiments of the present invention.

As shown in FIG. **7B**, adjustment brackets **704** may be configured with a slot **742** for accepting one or more bolts **740** therethrough. The slot **742** allows lengthwise adjustment of the adjustment bracket **704** relative to the vertical beam **702** for the desired height above ground **602** (FIG. **6A**). Adjust-

ment brackets **704** may also include a large mounting hole **744** for attachment to a vertical support bracket **800** (FIG. **6A**). Vertical beam **702** may include any number of small mounting holes **746** used to secure the adjustment brackets **704** to the vertical beam **702** using nuts, bolts and washers **740**. FIG. **7C** illustrates the "C" shaped cross-section of vertical beam **702** with the adjustment brackets **704** secured in opposing channels shown generally at **748**.

FIG. **7D** is a perspective view of a vertical support **700** illustrating a vertical adjustment assembly **780** used for precisely positioning the adjustment bracket **704** relative to vertical beam **702**. More particularly, FIG. **7D** shows adjustment bracket **704** to have a "C" shaped cross-section with a flange **752** disposed from a bottom end **754**. A long threaded bolt **756** is secured to flange **752** and a separate flange **758** mounted to vertical beam **702** in channel **748** with additional nuts **760** and optional washers (not shown for clarity). Vertical adjustment of the adjustment bracket **704** relative to the vertical beam **702** may be achieved by rotating a nut along threaded bolt **756** thereby acting upon flanges **752** and **758**. Once a desired position has been achieved, the nuts, bolts and washers **740** in slots **742** may be used to secure the position of the adjustment bracket **704** in the channel **748** of the vertical beam **702**. It will be understood that other means for vertically adjusting the precise height of the vertical supports **700** will be known to those skilled in the art. Such other means for making vertical adjustments are considered to be within the scope of the present invention.

Referring now to FIGS. **8A-D**, front, side, top and perspective views of an embodiment of a vertical support bracket **800** are shown according to the present invention. As shown in FIG. **8A**, vertical support bracket **800** may include a frame **802** supporting a plurality of struts **804**. Frame **802** supports a pivoting mount **806** configured to mate with large mounting holes **744** (FIG. **7B**) of the adjustment brackets **704** (FIG. **7B**).

As shown in FIG. **8B**, each of the struts **804** (two shown) may be configured for attachment to frame **802** at one end shown generally at **810** (FIGS. **8A-B**) and to the inside of structural member **250** (FIG. **2B**) at the other end shown generally at **812** (FIGS. **8A-B**) using nuts, bolts and washers **828** as necessary. Frame **802** may further include webbing **808** for additional structural rigidity and strength. FIG. **8C** illustrates a top view of an embodiment of a vertical support bracket **800**. Lateral adjustability of the struts **804** may be facilitated by slots **814** in the frame **802** for receiving the nuts, bolts and washers **828**.

FIGS. **9A-C** illustrate front, cross-section and perspective views of the attachment of vertical support bracket **800** to adjacent rail segments **402** (see also FIG. **4A**) of track **400** (see also FIGS. **4A-D**). As shown in FIG. **9A**, struts **804** may be bolted **828** to mounting holes **220** from within structural member **250**. The cross-section view of FIG. **9B** illustrates the internal placement of the struts **804** (two shown) within structural member **250**. As shown in FIGS. **9A-B**, nuts, bolts and washers **928** may be used to secure the frame **802** to the base panel **300** (FIG. **9B**). FIG. **9C** illustrates a perspective view of the attachment of vertical support bracket **800** to adjacent rail segments **402** of track **400**.

Referring again to FIG. **5E**, each wing **532** of coupling bar **500** may have a plurality of notches **534** formed along opposing edges **536** used for identification purposes. The notches **534** may correspond to various configurations of the coupling bars **500** used to introduce curves in a track **400**. The various configurations of the coupling bars **500** relate to a specified center spacing, s , as shown in FIG. **5E**, namely the spacing between the adjacent rows of mounting holes **520**. By having

13

a selectively variable distance, a , selective amounts of bend may be placed at the vertices **212** between adjacent rail segments **402**, thereby facilitating curves in track **400**. Generally, the greater the center spacing, s , the more bend may be introduced at the junction of two rail segments **402**. Table 1 below shows exemplary coupling bar **500** configurations based on the selectively variable center spacing, s , as that distance corresponds to notches **534** along an edge **536** of wing **532**.

TABLE 1

s (inches)	# of notches formed in edge along wing
3.000	0
3.063	1
3.125	2
3.188	3
3.250	4
3.313	5

In this way, track curvature may be varied significantly. FIGS. 5A-E, for example, illustrate $s=3.313$ inches.

The introduction of curves in a track **400** of a rail system **600** according to the present invention may be facilitated by using shorter straight rail segments **402**. For example a particular curvature may be achieved by using 10' rail segments **402**. Tighter curves in a track **400** may be achieved by using 5' lengths of rail segments **402**. Still tighter curves may be achieved by using 2.5' lengths of rail segments **402** and so on, until custom curved rail segments may be necessary.

Where greater track curvature is needed than can be accommodated using various lengths of straight rail segments **402** with curves introduced as bends at junctions with the various coupling bars **500** configurations, special preformed curved track sections may be introduced. For example, FIG. 10 is a drawing of an embodiment of a curved rail segment **1000**. Curved rail segment **1000** may be formed from inside **1002**, outside **1004** and bottom **1006** panels joined at three vertices **1012**. The vertices **1012** may be reinforced with piping **1014**, welded, or otherwise attached to the adjacent panels **1002**, **1004** and **1006** at the vertices **1012**. By selectively using curved rail segments **1000** at selected junctions between straight rail segments **402**, greater curvature may be achieved at various points along a given track **400**.

In order to use an autonomous car (not shown) with the novel tracks **400** describe herein, some form of drive mechanism (not shown) is needed to propel the car along the track **400**. One such drive mechanism is an electric motor (not shown) with pinion gear (not shown) configured to mate with a rack **1150**. FIGS. 11A-C illustrate side, end and detailed top views of a track **1100** with a rack **1150** according to embodiments of the present invention.

More particularly, FIG. 11A illustrates an end view of a rail segment **402** comprising a structural member **250** with base panel **300** forming a generally triangular cross-section. FIG. 11A further shows a rack **1150** mounted to structural member **250** with a rack bracket **1120**. FIGS. 21A-E illustrate front, top, side and perspective views of rack bracket **1120** and a flat template **1120A** from which a rack bracket **1120** may be patterned and formed according to an embodiment of the present invention. Rack bracket **1120** may have a generally "C" shaped cross-section with a first flange **1122** and slotted holes **1130** configured to mate with mounting holes **320** (FIG. 3A) of structural member **250**. Rack bracket **1120** further includes a second flange **1126** separated from, and generally parallel to, the first flange **1122** by intermediate section **1124** which is disposed perpendicular to flanges **1122** and **1126**.

14

Second flange **1126** is configured with a slotted hole **1130** to mount to rack mounting holes **1220** of rack **1150**.

Returning to FIG. 11A, the rack **1150** may be mounted to rack bracket **1120** with nuts, bolts and washers **1128** as shown in FIG. 11A. Similarly, the rack bracket **1120** may be mounted to structural member **250** with nuts, bolts and washers **1128** as shown in FIG. 11A. Placement and spacing of the rack brackets **1120** may be selected to assure the strength and rigidity of the rack **1150** for a particular transportation application.

Racks **1150** may be formed of a plurality of rack segments **1152** (FIG. 11B) each of any suitable length sufficient for attachment in serial fashion to form a rack **1150** that may be placed adjacent to a surface of the structural member **250** of track **1100** for any distance along track **1100** as may be needed. For example, and not by way of limitation, rack segments **1152** may come in lengths of 30", 45", 60", 75" and 120" to allow for modular assembly of a rack **1150**. Furthermore, though not illustrated, dual parallel racks mounted along the same face (one rack **1150** mounted above the other), or different faces (one rack **1150** on each of opposing sides), of track **1100** are also contemplated to be within the scope of the present invention. Such dual rack embodiments of the present invention may be used depending on the driving forces and the dispersal of loads required for a given track application.

FIG. 11B shows a side view of track **1100** with rack **1150**. The left side of FIG. 11B is indicated as "TOP STATION" and the right side of FIG. 11B is indicated as "BASE STATION" in accordance with a point-to-point track **1100** embodiment that may traverse a hill, for example. FIG. 11B further illustrates rack segments **1152** joined end-to-end or serially at joints **1104** as an assembly to form the rack **1150**. It will be understood that the dimensions shown in FIG. 11B are exemplary only and may be scaled or changed for particular applications of the inventive rail system of the present invention. The dimensions illustrated in FIGS. 11A-B are merely exemplary of particular embodiments of the present invention. Other suitable dimensions, for example scaling or otherwise, are considered to be within the scope of the present invention.

FIG. 11C is a detailed portion of a top view of track **1100** with rack **1150** as indicated by the arrows in FIG. 11B. As shown in FIG. 11C, the upper pair of nuts, bolts and washers **1128** may be staggered (lateral shifting) relative to the lower pair of nuts, bolts and washers **1128** for ease of installation. It will be understood that this staggering need not occur in other embodiments consistent with the present invention. It should be noted that because of the individual shape of each joint **1104** alignment that each of the vertices of the track **1100** may have different lengths of spacing relative to each other and to the track centroid. For this reason the mounting holes for the rack brackets **1120** and rack **1150** are deliberately selected such that the rack **1150** can be strung as an independent member relative to the track **1100** for any difference in length between the rack **1150** and track **1100** as may be required. As shown in FIGS. 21A-E, the slotted holes **1130** in the rack brackets **1120** are deliberately elongated (slotted) on first **1122** and second flanges **1126**, i.e., where the rack bracket **1120** attaches to the rack **1150** and where it attaches to the track **1100**. The slotted holes are configured to roughly correspond with the spacing of the mounting holes **220** in the track **1100** and mounting holes **1220** of the rack **1150**. The slotted holes **1130** allow for a "shift" in the mounting points between the rack **1150** and the track **1100**. It should also be noted that the rack **1150** can be made from various materials

including but not limited to nylon and other plastics as well as other metal types depending on the requirements of the rail system 600.

FIGS. 12A-D illustrate front, top, side and detailed views of an embodiment of a rack segment 1152, according to the present invention. As shown in FIG. 12A, the rack segment 1152 is comprised of a plurality of regularly spaced teeth 1202 and a plurality of mounting holes 1220. The teeth 1202 of rack segment 1152 are configured to cooperate with a pinion gear (not shown) attached to a motor (not shown) of a car (not shown), thus enabling the car to traverse the track 1100 (FIG. 11B). Mounting holes 1220 are used to attach the rack segment 1152 to a rack bracket 1120 (FIG. 11A). FIGS. 12B-C illustrate top and side views of the rack segment 1152, respectively. The dimensions shown in FIGS. 12B-C are exemplary and not intended to be limiting of the invention. For example, the nominal length of approximately 30" shown for rack segment 1152 is for one particular embodiment. Other embodiments of rack segment 1152 may include lengths of approximately 45", 60", 75" and 120". These rack segment 1152 lengths may or may not coincide with lengths of rail segments 402 (FIG. 4A). It will be understood that any length of rack 1150 (or rack segments 1152) for use with track 1100 (FIG. 11B) is consistent with the principles of the present invention. Similarly, in FIG. 12C, the presently preferred thickness of rack segment 1152 (and rack 1150) is shown to be 1/4". However, it will be understood that other thicknesses (thicker or thinner) sufficient for the application described herein are contemplated to be within the scope of the present invention and may be preferred for other applications or loading constraints.

FIG. 12D is a detailed view of a portion of the rack segment 1152 as indicated by the circular arrows in FIG. 12A. It will be understood that the particular dimensions illustrated in FIGS. 12A-D are merely exemplary of particular embodiments of the present invention. Other suitable dimensions, for example scaling or otherwise, are considered to be within the scope of the present invention.

Referring now to FIGS. 13-15, various views of an embodiment of a rail system 1300 are shown according to the present invention. FIG. 13 illustrates a perspective view looking down from the top station 1302 or end point of the rail system 1300 in an actual installation on a mountain. As shown in FIG. 13, rail system 1300 may include a track 1100 supported above ground 602 by vertical supports 700. FIG. 13 also illustrates rack 1150 installed on track 1100. FIG. 14 is another view of rail system 1300 looking up from an intermediate location between a base station (not shown) and top station 1302 (FIG. 13). FIG. 15 illustrates another view of rail system 1300 looking up from another intermediate location between a base station (not shown) and top station 1302 (FIG. 13). FIGS. 14 and 15 both illustrate the track 1100 with rack 1150 supported by vertical supports 700 above ground 602.

A particular embodiment of a rail system 1300 may include a plurality of rail segments 402. The quantity of rail segments 402 may be determined by the particular application for rail system 1300, e.g., the distance from a base station to a top station. Each rail segment 402 may include a triangular prism-shaped structural member 250 having an equilateral triangle cross-section, wherein one side of the equilateral triangle includes a gap between two opposed co-planar lips 218 extending from adjacent vertices 412. Each rail segment 402 may further include an elongated rectangular base panel 300 connected to the lips 218 of the structural member 250, thereby closing the gap 226.

The embodiment of a rail system 1300 may further include a plurality of coupling bars 500 configured for attaching the

plurality of rail segments 402 end-to-end from inside adjacent vertices 412 of adjacent end-to-end rail segments 402 to form a track 400. According to another embodiment, rail system 1300 may further include a rack 1150 configured to be attached to a surface of the track 1100. The rack 1150 may be configured with teeth 1202 for receiving and engaging a pinion gear (not shown). According to yet another embodiment, rail system 1300 may further include a plurality of rack brackets 1120 each configured for mounting the rack 1150 to the track 1100. According to yet another embodiment of rail system 1300, each of the rack brackets 1120 is configured to hold the rack 1150 at a fixed distance parallel to the track 1100. According to another embodiment of rail system 1300, the rack 1150 may further include a plurality of rack segments 1152 configured to be placed together serially to form a rack 1150 of arbitrary length.

Another embodiment of rail system 1300 may further include a plurality of vertical supports 700 for supporting the track 400, 1100 above ground 602. According to another embodiment of rail system 1300, each vertical support 700 may include a vertical beam 702. According to this embodiment, vertical support 700 may further include a vertical support bracket 800 configured to attach the vertical beam 702 to the track 400, 1100. According to this embodiment, vertical support 700 may further include a footing frame 738 configured for placement into a concrete footing or foundation 604 and configured for attachment to the vertical beam 702. According to this embodiment, the length of the vertical beam 702 may be adjustable for precise placement of the track 400, 1100 above ground 602.

Another embodiment of rail system 1300 may further include at least one reaction assembly 690 for providing lateral support to a track 400, 1100. According to this embodiment, the reaction assembly 690 may include four reaction frames 660 each adjustable in length and configured with a first end attachable to vertical support brackets 800 attached to the track 400, 1100. According to this embodiment, the reaction assembly 690 may further include a lateral support bracket 650 configured for placement in a concrete footing or foundation 604 and configured for receiving a second end of each of the four reaction frames 660.

It will be understood that the rail system 1300 disclosed herein may be used over virtually any suitable terrain topography for transporting payloads. The types of payload carried on rail system 1300 are also virtually unlimited, for example and not by way of limitation, people, equipment, goods, ore, etc. The flexibility of rail system 1300 may also be visualized by describing or illustrating, in map view, a path or paths traversed along the centroid 440 (FIGS. 4A-B and 4D) of the track 400, 1100.

Referring to FIGS. 16A-C, exemplary paths which may be traversed by rail system 1300 are shown. More particularly, in FIG. 16A, a path 1602 between points A and B is shown. Path 1602 may traverse level ground or may traverse hills and valleys as the application requires. FIG. 16B illustrates a path, shown generally at arrow 1604, which has a main trunk line 1606 running between points C and D. Path 1604 also includes spurs 1608 and 1610 branching from the main trunk line 1606 to points E and F, respectively. FIG. 16C illustrates a circular path 1612 which may have any number of stops (not shown) along its circumference. It will be understood that rail system 1300 may be configured with any combination or subset of paths 1602, 1604 and 1612, consistent with the present invention.

According to one embodiment of rail system 1300, a track centroid 440 traverses a non-linear path. According to another embodiment of rail system 1300, the path 1602 connects two

points (A and B) in a point-to-point configuration. According to yet another embodiment of rail system **1300**, the path may include a main trunk line **1606** with at least one spur **1608** and **1610**. In still another embodiment of rail system **1300**, the path **1612** includes at least one loop.

Junctions **1614** in the main trunk line **1606** may be effected in many ways known to one of skill in the art. For example, the use of a perpendicularly sliding track portion (not shown, but commonly used in amusement park rides) may be used to selectively switch a vehicle onto a spur **1608** and **1610**. Such a perpendicularly sliding track portion has two positions. In the first position a vehicle passes straight through as if there were no junction **1614**. In the second position obtained by shifting the perpendicularly sliding track portion at 90° (perpendicular) to the direction of vehicle travel along the track, a curved portion of track within the perpendicularly sliding track portion directs a vehicle to the spur **1608** or **1610**.

The elevated rail system **600** of the present invention utilizes simple components, that are easily assembled and is economical to produce. The simplicity of the system reduces the track design process substantially. The elevated rail system **600** of the present invention is preferable to prior art approaches for dealing with the problems associated with thermal expansion in a long track system.

The embodiment of rail segments **402** formed from folding rectangular main panel **200** and attaching elongated rectangular base panel **300** disclosed herein is only one method of forming a structural member having a triangular cross-section or triangular prism shape. Other embodiments utilizing one or two components selectively processed or assembled are also disclosed herein.

Referring to FIGS. **17A-C** another embodiment of a triangular prism-shaped rail segment **1716** formed from a bottom plate **1702** and a top rib **1704** is illustrated, according to the present invention. More particularly, FIG. **17C** illustrates a top view of an unfolded bottom plate **1702** having a bottom portion **1706** between two fold lines **1708**. Bottom plate **1702** may include two leafs **1710** configured to be folded up and toward bottom portion **1706**, each at an angle of 60° relative to the bottom portion **1706**. The unfolded bottom plate **1702** may be formed from a section of galvanized steel or other material in any suitable width, $42''$ shown. The galvanized steel or other material may be of any suitable gauge, for example and not by way of limitation, 11 gauge steel. The bottom plate **1702** may include optional cut-outs **1714** to allow water and wind to pass through rail segments **1716** (FIG. **17A**). Each rail segment **1716** may be joined at a joint **1718**, using coupling bars **500** (FIGS. **4A-D**) or other means of securing as known to those skilled in the art. Each leaf **1710** may be formed of a plurality of teeth **1712**.

FIG. **17B** is a top view of sheet stock **1720** which may be used to cut three unfolded top ribs **1704**. Sheet stock **1720** may have any suitable width, e.g., $52''$ shown. Each top rib **1704** includes a fold line **1708** and a plurality of regularly spaced teeth **1712**. Each unfolded top rib **1704** is configured to be folded along fold line **1708** such that opposing teeth **1712** are at an angle of 60° relative to one another.

FIG. **17A** illustrates a side view of portions of two triangular prism-shaped rail segments **1716** assembled end-to-end at joint **1718** as a track **1700**. Each triangular prism-shaped rail segment **1716** may be formed from a folded bottom plate **1702** mated with a top rib **1704**. The mating of bottom plate **1702** to top rib **1704** may be achieved by overlapping corresponding teeth **1712** and welding or fastening with nuts and bolts (not shown) as known to those skilled in the art. A rack **1150** may be attached to the assembled triangular prism-shaped rail segment **1716** as shown in FIG. **17A**. In this way,

triangular prism-shaped rail segments **1716**, each having an equilateral triangle cross-section, may be formed. It will be understood that each side of the equilateral triangle may have any suitable dimension, e.g., approximately $20''$ in the illustrated embodiment. Track **1700** may be supported above ground with vertical supports **700** and reaction assemblies **690** as disclosed herein.

Referring now to FIGS. **18A-B**, yet another embodiment of a triangular prism-shaped rail segment **1806** formed of a single sheet stock **1802** is shown, according to the present invention. More specifically, FIG. **18B** illustrates a top view of a sheet stock **1802** with three panels **1804** separated by two fold lines **1808**. Sheet stock **1802** may be formed of any suitable material, for example and not by way of limitation, galvanized steel. It will be understood that sheet stock **1802** may be formed with any suitable thickness of material, for example 10 gauge steel as shown in FIG. **18B**. It will also be understood that the dimensions of sheet stock **1802** may be arbitrarily selected depending on the particular application. For example and not by way of limitation, sheet stock **1802** may have a width of approximately $48''$ and a length of approximately $120''$ as shown in FIG. **18B**. Folding sheet stock **1802** along fold lines **1808**, so that the outside panels **1804** are folded in toward the center panel **1804**, a triangular prism-shaped rail segment **1806** may be formed. FIG. **18A** is a side view of two triangular prism-shaped rail segments **1806** assembled end-to-end at joint **1818** to form a portion of a track **1800**. Track **1800** may be supported above ground with vertical supports **700** and reaction assemblies **690** as disclosed herein.

The equilateral triangle cross-section of rail segments **402** (FIG. **4A**) is a presently preferred configuration of the structural members **250** (FIGS. **2B-D**) disclosed herein. However, it will be understood that similar hollow structural members may also be used for various applications (e.g., rail systems, towers and the like) consistent with the inventive concepts of the present invention. FIGS. **19A-F** illustrate various alternative embodiments of structural member cross-sections which may be employed for rail systems, towers and the like, consistent with the principles of the present invention. Such structural members may be used to form tracks with racks and support structures for use in a railed transportation system in a manner analogous to track **400** (FIGS. **4A-D**) and rail systems **600** and **1300** disclosed herein.

More particularly, FIG. **19A** illustrates a cross-section view of a generally equilateral triangular cross-sectioned structural member **1900** which may be formed from flat sheet stock (not shown) folded to form side panels **1902** with lips **1904** for engaging an adjacent side panel **1902**. Internal angles may all be approximately 60° as shown to form a cross-section that is approximately an equilateral triangle. Other embodiments having side panels **1902** may employ other internal angles such that the cross-section forms an isosceles triangle, consistent with the present invention.

For example, FIG. **19B** illustrates a cross-section view of a generally isosceles triangular cross-sectioned structural member **1910**. The structural member **1910** may include a triangular prism-shaped structural member **1912** having lips **1914** that are at approximately 75° relative to sides **1916**. The triangular prism-shaped structural member **1912** further includes a top vertex having an internal angle of approximately 30° relative to sides **1916**. The structural member **1910** may further include a rectangular base panel **1918**, similar to rectangular base panel **300** (FIG. **3A**), attached to the lips **1914**. Attachment of the rectangular base panel **1918** to the lips **1914** of the triangular prism-shaped structural member **1912** may be achieved with nuts and bolts (not

shown), clamping mechanisms (not shown), welding (not shown), or any other suitable means for attachment consistent with the principles of the present invention. It will be understood that the particular internal angles shown in FIG. 19B are merely exemplary and other suitable internal angles may be used consistent with the present invention.

FIG. 19C illustrates a cross-section view of another embodiment of an isosceles triangular cross-sectioned structural member 1920. Structural member 1920 includes a top section 1922 having an inverted "V" cross-section having internal angle, β . Structural member 1920 further includes a bottom section 1924 having lips 1926 angled up to engage top section 1922. Lips 1926 may be configured with any suitable internal angle, Θ , such that $2\Theta + \beta = 180^\circ$. Attachment of the lips 1926 to the top section 1922 may be achieved with nuts and bolts (not shown), clamping mechanisms (not shown), welding (not shown), or any other suitable means for attachment consistent with the principles of the present invention. It will be readily understood that according to an embodiment where $\Theta = \beta$, structural member 1920 will have an equilateral triangular cross-section.

FIG. 19D illustrates a cross-section view of yet another embodiment of a hexagonal cross-sectioned structural member 1930 formed of three panels 1932. Each panel 1932 may be formed from flat sheet stock with suitable bending to form lips 1934, short sides 1936 and long sides 1938. According to structural member 1930, lips 1934 are configured to be attached to a long side 1938 of an adjacent panel 1932. It will be understood that attachment of lips 1934 to long sides 1938 may be achieved with nuts and bolts (not shown), clamping mechanisms (not shown), welding (not shown), or any other suitable means for attachment consistent with the principles of the present invention. In an alternative embodiment of structural member 1930, panels 1932 do not include lips 1934. In this alternative embodiment, the distal ends of each short side 1936 (which would have included lip 1934) attached to a distal end of a long side 1938 in an adjacent panel 1932, for example by welding. As can be seen in FIG. 19D, such a hexagonal cross-sectioned structural member 1930 may fit within a triangular cross-section 1908 (shown in dotted line).

FIG. 19E illustrates a cross-section view of still another embodiment of a triangular cross-sectioned structural member 1940 consistent with the principles of the present invention. Structural member 1940 may include three triangular webs 1942 having a triangular prism-shaped cross section located at each vertex formed by the joining of three side panels 1944. It will be understood that the three side panels 1944 may be formed from a single sheet stock 1802 (FIG. 18B) bent appropriately at fold lines 1808 (FIG. 18B) according to one embodiment and as described herein. Alternatively, each panel 1944 may be a separate panel 1944 to be joined to the webs 1942 using nuts and bolts (not shown), clamping mechanisms (not shown), welding (not shown), or any other suitable means for attachment consistent with the principles of the present invention. The cross-section of structural member may be equilateral (shown) or isosceles, according to various embodiments of the present invention.

FIG. 19F illustrates a cross-section view of still another embodiment of a triangular cross-sectioned structural member 1950 consistent with the principles of the present invention. According to one embodiment, structural member 1950 may be formed by joining four smaller triangular prism-shaped structural members 1952 together as shown in FIG. 19F. According to another embodiment, structural member 1950 may be formed by placing a center smaller triangular prism-shaped structural member 1952A within a larger out-

side triangular prism-shaped structural member 1954 and attaching as shown in FIG. 19F. It should also be noted that the generally triangular prism-shaped structural members disclosed herein may also be formed with sides each having a different gauge or thickness of material used to form each panel according to other embodiments of the present invention. Such variations in thickness of specific panels may be used to further customize strength and weight aspects of portions or all of a track in a given application.

Another general embodiment of a rail system is disclosed. The rail system may include a track 400 and 1100 formed of a plurality of elongated hollow structural members joined end-to-end. The elongated hollow structural members may have cross-sections such as structural members 402, 1900, 1910, 1920, 1930, 1940 and 1950 shown herein. The rail system may further include a plurality of vertical supports 700 for elevating the track 400 and 1100 above concrete foundations 604 formed in ground 602. The rail system may further include at least one reaction assembly 690 placed between adjacent vertical supports 700, the track 400 and 1100 and the concrete foundations 604 having pivot points 606 near the track 400 and 1100 and having pivot points 806 near the concrete foundations 604, the reaction assembly 690 allowing for local containment of stresses due to thermal expansion of the track. The outline of a cross-section of the elongated hollow structural member 402, 1900, 1910, 1920, 1930, 1940 and 1950 may be an equilateral triangle, an isosceles triangle or a hexagon.

While the foregoing advantages of the present invention are manifested in the detailed description and illustrated embodiments of the invention, a variety of changes can be made to the configuration, design and construction of the invention to achieve those advantages. For example, it will be understood that one of ordinary skill in the art will readily recognize that various combinations and extensions of the illustrated structural member cross-sections shown in FIGS. 4A-D and 19A-F may be achieved consistent with the principles of the present invention. All of those variations and alternative embodiments are considered to be within the scope of the present invention. Hence, reference herein to specific details of the structure and function of the present invention is by way of example only and not by way of limitation.

What is claimed is:

1. An elevated rail system, comprising:
 - a track formed of a plurality of elongated hollow structural members joined end-to-end;
 - a plurality of vertical supports for selectively elevating the track above ground, each vertical support further comprising:
 - a vertical beam secured at a first end to a concrete foundation;
 - dual adjustment brackets slideably engaging a second end of the vertical beam to allow for precise elevation of the track; and
 - a pivot mechanism disposed between the track and the dual adjustment brackets configured to prevent buildup of stresses caused by thermal expansion or contraction of the track; and
 - a reaction assembly rotationally coupled to the pivot mechanism and anchored to a concrete foundation, the reaction assembly disposed between adjacent vertical supports, ground and the track, the reaction assembly anchoring local stresses caused by the thermal expansion or contraction of the track.

21

2. The elevated rail system according to claim 1, wherein each of the pivot mechanisms comprises pivot points rotationally coupling the track to the vertical support.

3. The elevated rail system according to claim 1, wherein each of the vertical supports further comprise a vertical support bracket coupled to the track, the vertical support bracket comprising:

a frame supporting pivot points rotationally engaged to the dual adjustment brackets of the vertical support; and a plurality of struts securing the track to the frame.

4. The elevated rail system according to claim 1, wherein the pivot mechanism allows lengthwise expansion or contraction of the track in either direction along the track away from the reaction assembly.

5. The elevated rail system according to claim 1, wherein the reaction assembly further comprises:

a lateral support bracket mounted within a concrete foundation; and

two coplanar reaction frames each connected at a first end to the lateral support bracket and connected at a second end to a first vertical support bracket.

6. The elevated rail system according to claim 5, wherein the reaction assembly further comprises two more coplanar reaction frames each connected at a first end to the lateral support bracket and connected at a second end to second vertical support bracket.

7. The elevated rail system according to claim 5, wherein each of the coplanar reaction frames further comprise adjustability in length.

8. The elevated rail system according to claim 1, wherein each of the vertical supports further comprises:

a footing frame mounted within each of the concrete foundations for receiving the first end of the vertical beam; and

two eccentric bolt and washer assemblies adjustably connecting the footing frame to the first end of the vertical beam, allowing for precise adjustment of vertical inclination of the vertical support.

9. The elevated rail system according to claim 8, wherein each of the eccentric bolt and washer assemblies allows the first end of the vertical beam to be adjusted horizontally and vertically relative to the footing frame by axially rotating the eccentric bolt.

10. The elevated rail system according to claim 1, wherein each of the adjustment brackets is configured to slide axially against the second end of the vertical beam, thereby providing arbitrary vertical adjustment in length of the vertical support between the track and the concrete foundations.

11. An elevated rail system, comprising:

a plurality of hollow triangular prism-shaped rail segments, each rail segment forming a piecewise linear segment of a track;

a plurality of vertical supports rotationally coupled to the track for selectively elevating the track above ground, each of the vertical supports comprising:

a vertical beam with first end secured to a concrete foundation;

a vertical support bracket coupled to the track having two pivot points;

a pair of adjustment brackets disposed between the vertical beam and the vertical support bracket, the adjustment brackets each having a lower end slideably engaging a second end of the vertical beam to allow for precise elevation of the track, the adjustment brackets each having an upper end rotationally coupled to one of the pivot points; and

22

wherein the rotational coupling of the pivot points allows the track to expand or contract along its centroid due to thermal expansion.

12. The system according to claim 11, further comprising a reaction assembly coupled at a track end to one of the plurality of vertical supports and anchored at a foundation end to a concrete foundation, the reaction assembly disposed between adjacent vertical supports, the ground and the track, the reaction assembly anchoring local stresses caused by the thermal expansion or contraction of the track.

13. The system according to claim 11, wherein each of the vertical supports further comprises:

a footing frame mounted within each of the concrete foundations for receiving the first end of the vertical beam; and

two eccentric bolt and washer assemblies adjustably connecting the footing frame to the first end of the vertical beam, allowing for precise adjustment of vertical inclination of the vertical support.

14. An elevated rail system, comprising:

a plurality of rail segments, each rail segment forming a piecewise linear segment of a track; and

a plurality of vertical supports rotationally coupled to the track for selectively elevating the track above ground, each of the vertical supports comprising:

a vertical beam with first end secured to a concrete foundation;

a footing frame mounted within each of the concrete foundations for receiving a first end of the vertical beam;

two eccentric bolt and washer assemblies adjustably connecting the footing frame to the first end of the vertical beam, the eccentric bolt and washer assemblies allowing for precise adjustment of vertical inclination of the vertical support;

a vertical support bracket attached to the track, the vertical support bracket further comprising two pivot points;

two adjustment brackets, each adjustment bracket having a pivot end rotationally coupled to each of the two pivot points; and

slide ends of the two adjustment brackets slidably attached to a second end of the vertical beam.

15. The elevated rail system according to claim 14, wherein the vertical support bracket further comprises:

a frame supporting two pivot points rotationally engaged to the pivot ends of the adjustment brackets of the vertical support; and

a plurality of struts securing the track to the frame.

16. The elevated rail system according to claim 14, further comprising a reaction assembly coupled at a track end to one of the plurality of vertical supports and anchored at a foundation end to a concrete foundation, the reaction assembly disposed between adjacent vertical supports, the ground and the track, the reaction assembly anchoring local stresses caused by the thermal expansion or contraction of the track.

17. An elevated rail system, comprising:

a track having arbitrary length and configured for supporting a vehicle; and

a plurality of vertical supports configured for selectively elevating the track above concrete foundations formed in ground, the plurality of vertical supports each further comprising:

a vertical support bracket attached to the track including two pivot points;

a vertical beam oriented vertically between the track and one of the concrete foundations; and

two adjustment brackets, each rotationally connected to one of the two pivot points and slidably attached to the vertical beam, each of the two adjustment brackets further comprising a threaded bolt disposed between the adjustment bracket and the vertical beam, the threaded bolt providing micro-adjustment of height of the track above the one concrete foundation. 5

18. The elevated rail system according to claim **17**, further comprising a reaction assembly having a track end coupled to one of the plurality of vertical supports and further having a foundation end anchored to a concrete foundation, the reaction assembly anchoring local stresses caused by thermal expansion or contraction of the track. 10

19. The elevated rail system according to claim **18**, wherein the vertical support bracket further comprises: 15

a frame supporting the two pivot points rotationally engaged to the dual adjustment brackets of the vertical support;

the track end of the reaction assembly attached to the frame; and 20

a plurality of struts securing the track to the frame.

* * * * *