

US008507789B2

(12) **United States Patent**
Ko et al.

(10) **Patent No.:** **US 8,507,789 B2**
(45) **Date of Patent:** ***Aug. 13, 2013**

(54) **SOLAR CELL AND METHOD OF MANUFACTURING THE SAME**

(75) Inventors: **Jihoon Ko**, Seoul (KR); **Juwan Kang**, Seoul (KR); **Jonghwan Kim**, Seoul (KR); **Daehee Jang**, Seoul (KR)

(73) Assignee: **LG Electronics Inc.**, Seoul (KR)

(*) Notice: Subject to any disclaimer, the term of this patent is extended or adjusted under 35 U.S.C. 154(b) by 0 days.

This patent is subject to a terminal disclaimer.

(21) Appl. No.: **13/475,659**

(22) Filed: **May 18, 2012**

(65) **Prior Publication Data**

US 2012/0227804 A1 Sep. 13, 2012

Related U.S. Application Data

(63) Continuation of application No. 12/559,542, filed on Sep. 15, 2009, now Pat. No. 8,203,072.

(30) **Foreign Application Priority Data**

Jun. 22, 2009 (KR) 10-2009-0055379

(51) **Int. Cl.**

H01L 31/0216 (2006.01)

H01L 31/0224 (2006.01)

(52) **U.S. Cl.**

USPC **136/256**; 136/255; 136/252; 438/72; 438/98; 438/68; 438/83; 438/94; 438/57; 257/53; 257/184; 257/431; 257/774

(58) **Field of Classification Search**

USPC 136/255, 256, 252; 438/72, 98, 438/68, 83, 94, 57; 257/53, 184, 431, 774

See application file for complete search history.

(56) **References Cited**

U.S. PATENT DOCUMENTS

3,903,427 A * 9/1975 Pack 250/208.2
3,903,428 A * 9/1975 DeJong 136/244

(Continued)

FOREIGN PATENT DOCUMENTS

JP 2001-68693 A 3/2001
JP 2008-34609 A 2/2008

(Continued)

OTHER PUBLICATIONS

Xu et al., "Electronic structure and optical properties of α and β phases of silicon nitride, silicon oxynitride, and with comparison to silicon dioxide", Physical Review B; vol. 51, No. 24; pp. 17379-17389; Jun. 1995.

Primary Examiner — Jennifer Michener

Assistant Examiner — Golam Mowla

(74) *Attorney, Agent, or Firm* — Birch, Stewart, Kolasch & Birch, LLP

(57) **ABSTRACT**

A solar cell and a method of manufacturing the same are disclosed. The solar cell includes a substrate of a first conductive type having at least one via hole; an emitter layer only on at least a portion of the via hole and at least one selected from a group consisting of an incident surface and side surfaces of the substrate, the emitter layer having a second conductive type opposite the first conductive type; at least one first electrode on the incident surface, the first electrode being electrically connected to the emitter layer; a second electrode connected to an opposite surface to the incident surface; and at least one first electrode current collector on the opposite surface, the at least one first electrode current collector being insulated from the second electrode and being electrically connected to the at least one first electrode through the via hole.

17 Claims, 8 Drawing Sheets

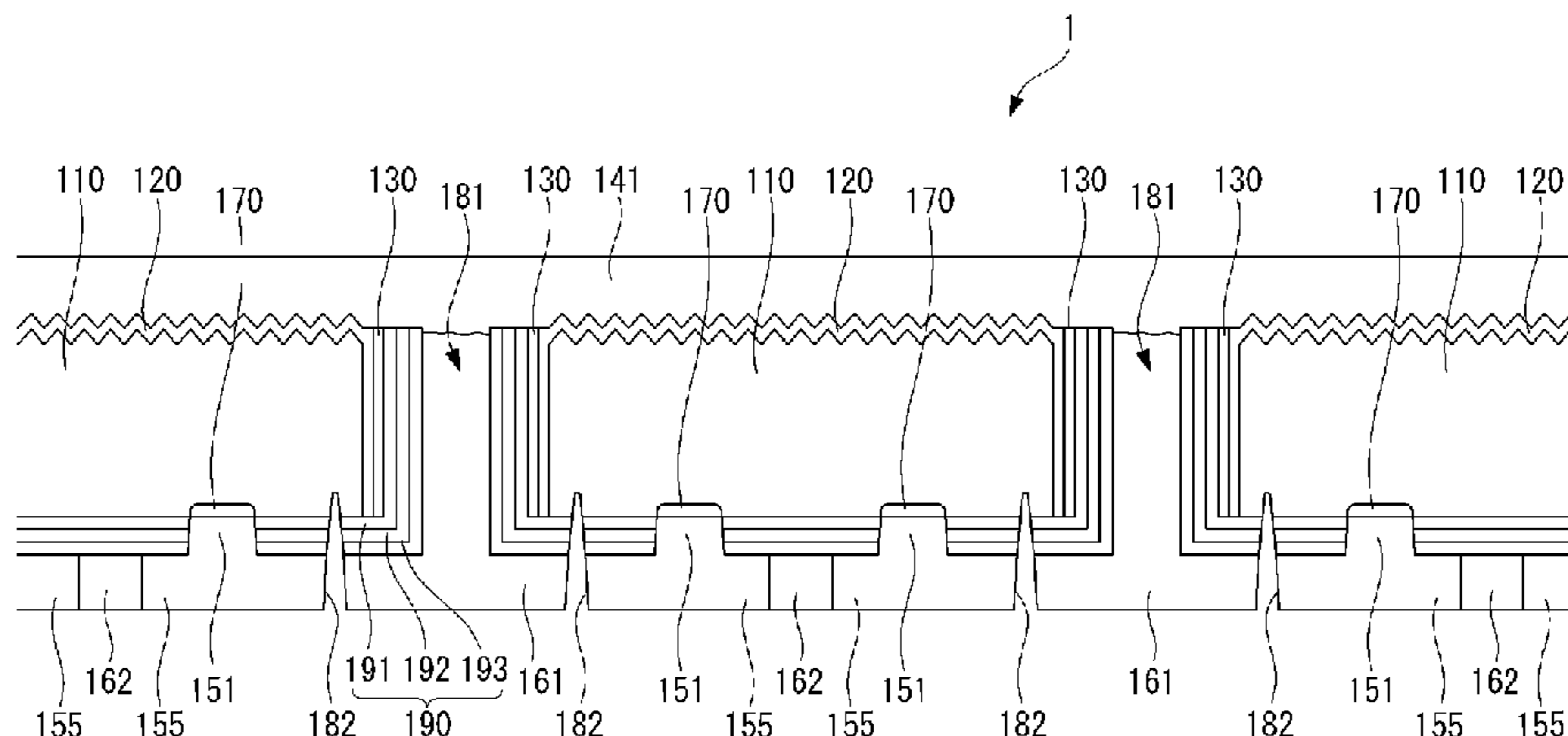

(56)

References Cited

U.S. PATENT DOCUMENTS

4,828,628 A 5/1989 Hezel et al.
4,838,952 A * 6/1989 Dill et al. 136/256
5,259,891 A * 11/1993 Matsuyama et al. 136/244
5,380,553 A 1/1995 Loboda
5,421,908 A * 6/1995 Yoshida et al. 136/244
5,468,988 A * 11/1995 Glatfelter et al. 257/431
6,384,317 B1 5/2002 Kerschaver et al.
6,730,594 B2 * 5/2004 Noguchi et al. 438/653
2005/0176164 A1 * 8/2005 Gee et al. 438/48
2006/0060238 A1 3/2006 Hacke et al.
2006/0112987 A1 6/2006 Nakata et al.

2006/0130891 A1 6/2006 Carlson
2007/0023082 A1 2/2007 Manivannan et al.
2007/0235075 A1 10/2007 Park
2008/0099871 A1 5/2008 Bui et al.
2009/0314346 A1 * 12/2009 Hishida 136/258

FOREIGN PATENT DOCUMENTS

JP 2008-227269 A 9/2008
KR 10-2005-0094406 A 9/2005
KR 10-2006-0069306 A 6/2006
KR 10-0682017 B1 2/2007
KR 10-2007-0099938 A 10/2007
KR 10-2008-0032866 A 4/2008

* cited by examiner

FIG. 1

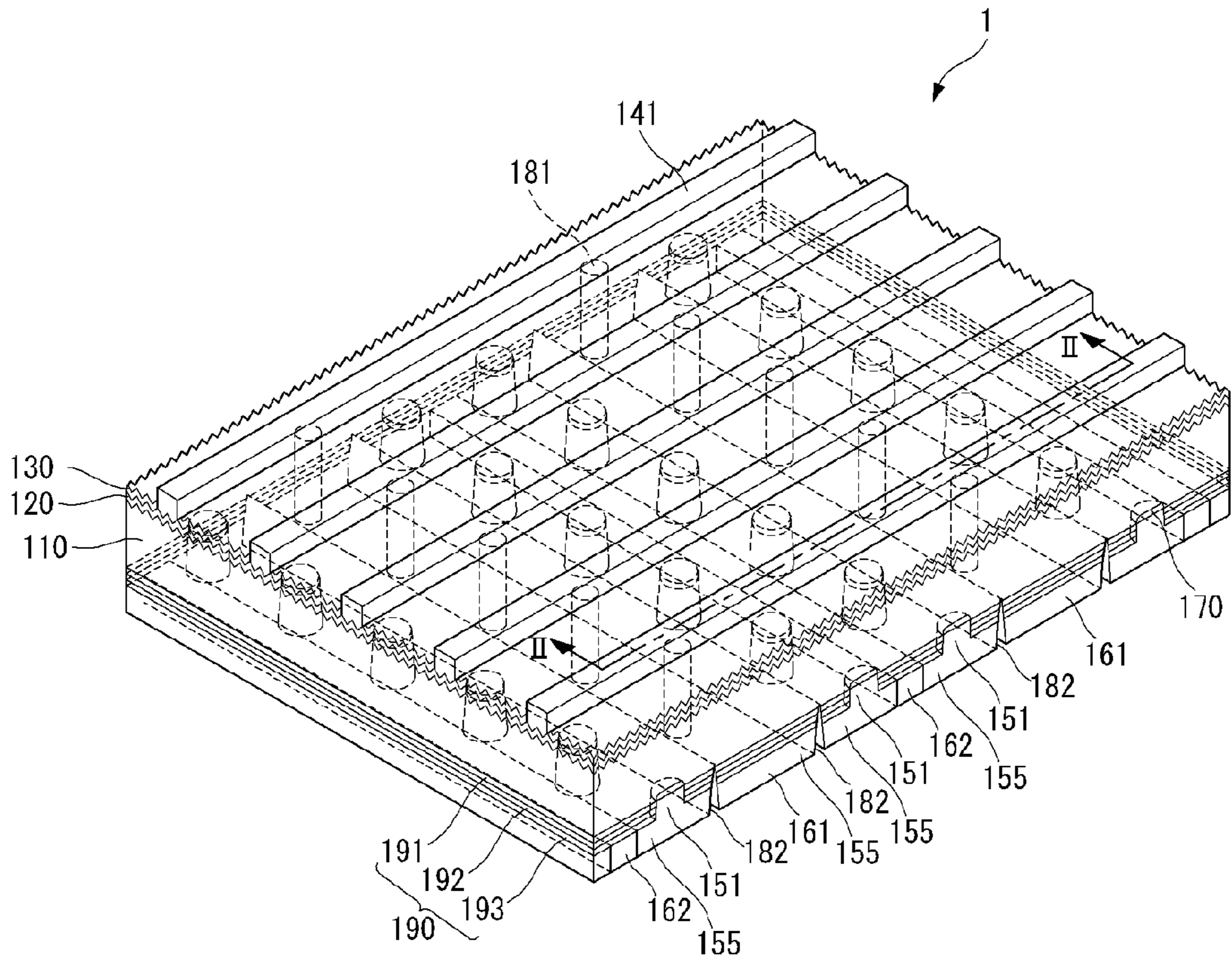

FIG. 2

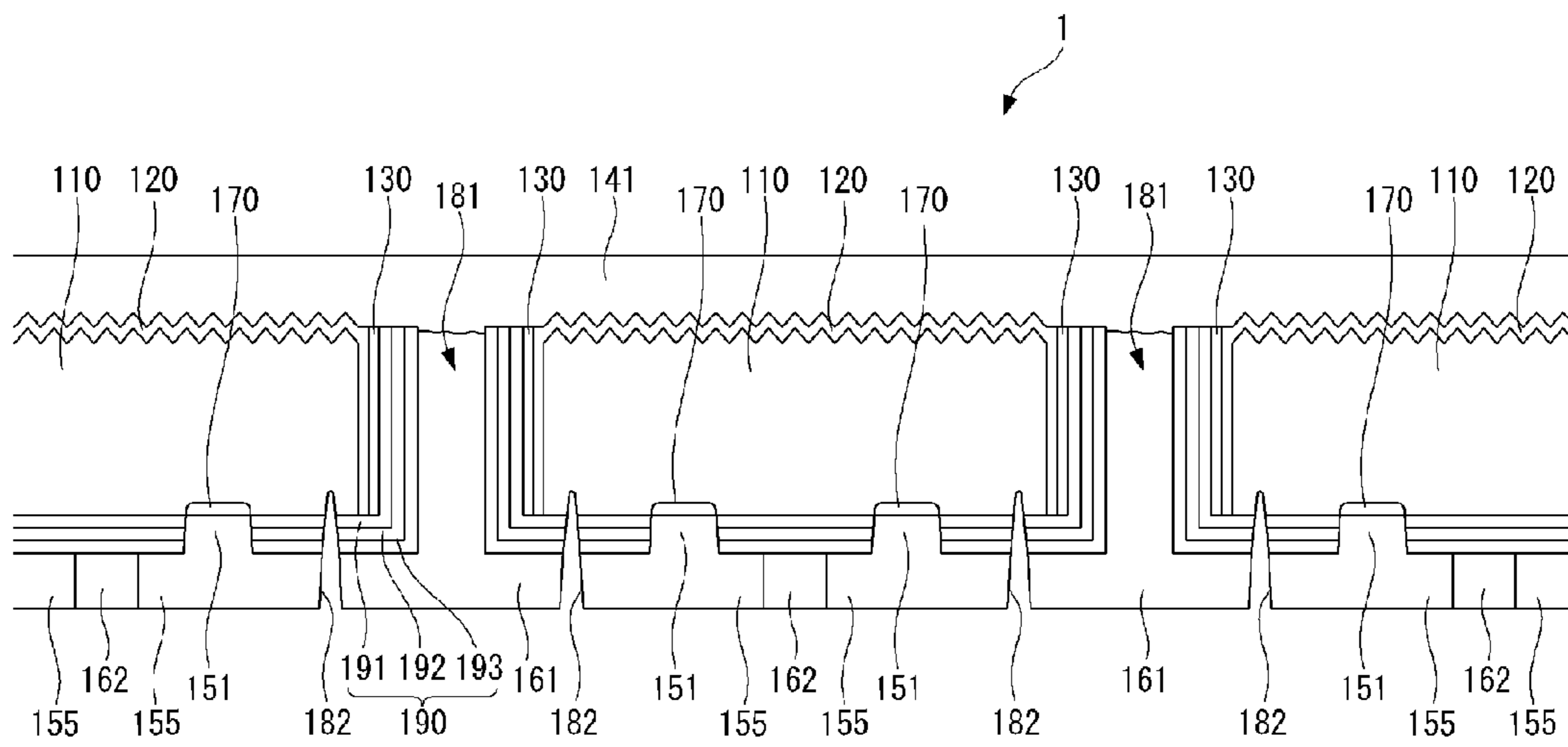

FIG. 3A-3

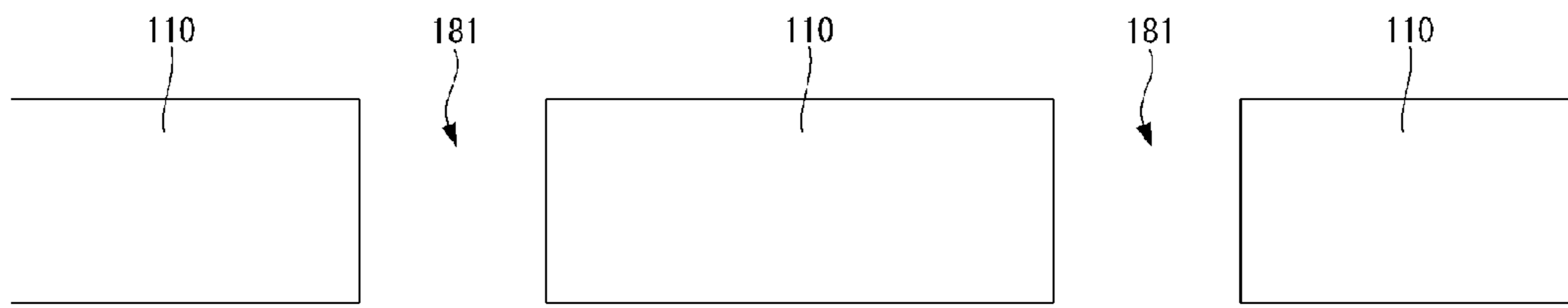

FIG. 3B-4

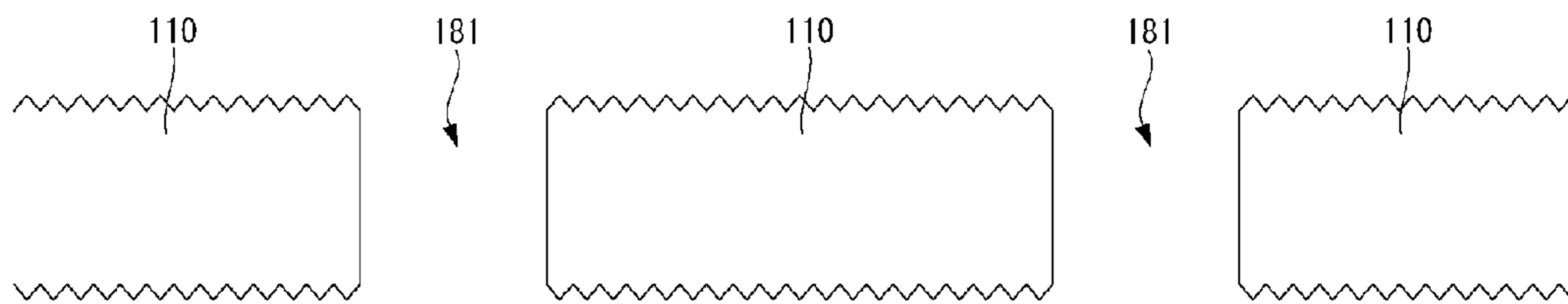

FIG. 3C-5

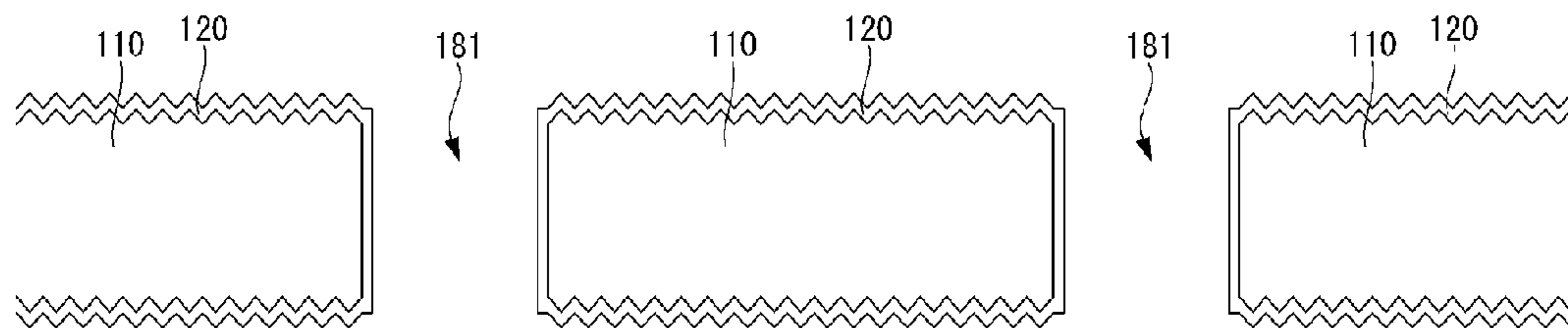

FIG. 3D-6

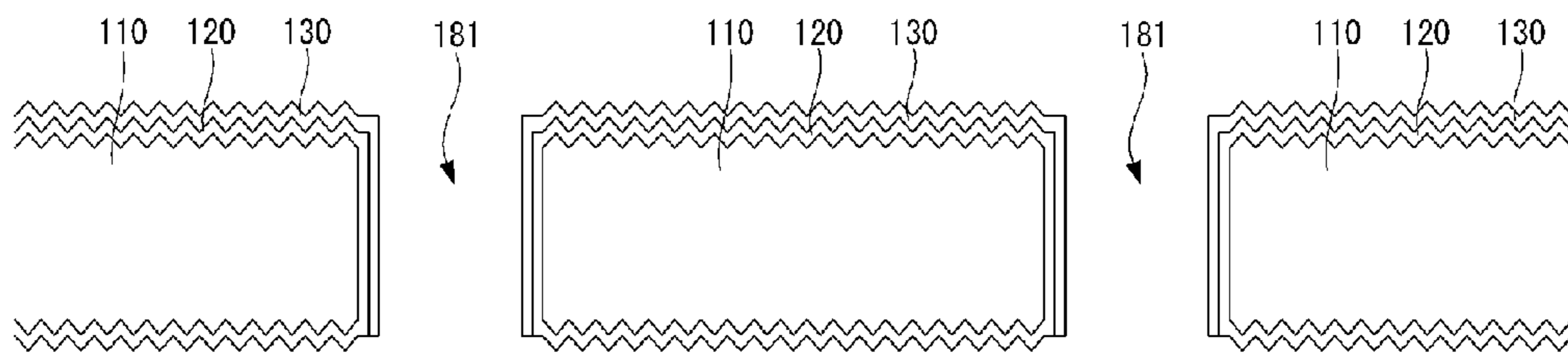

FIG. 3E-7

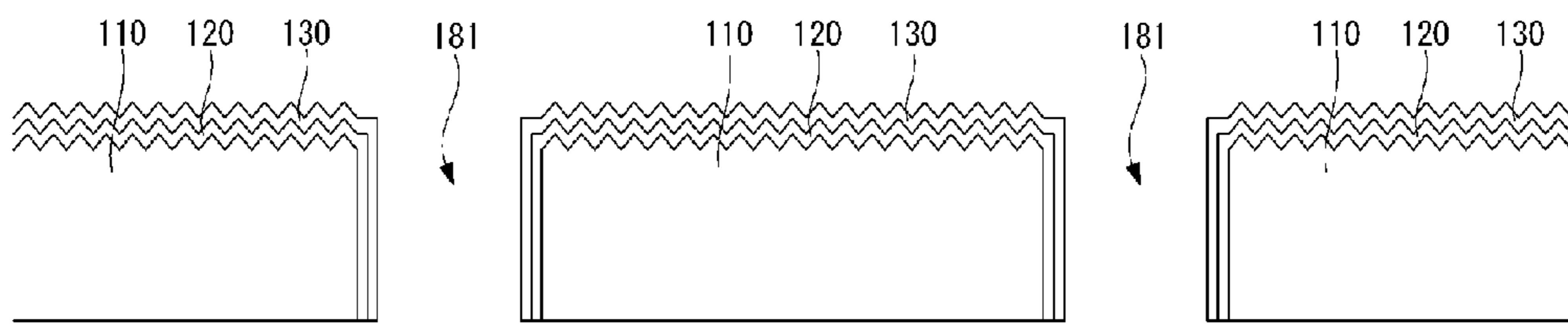

FIG. 3F-8

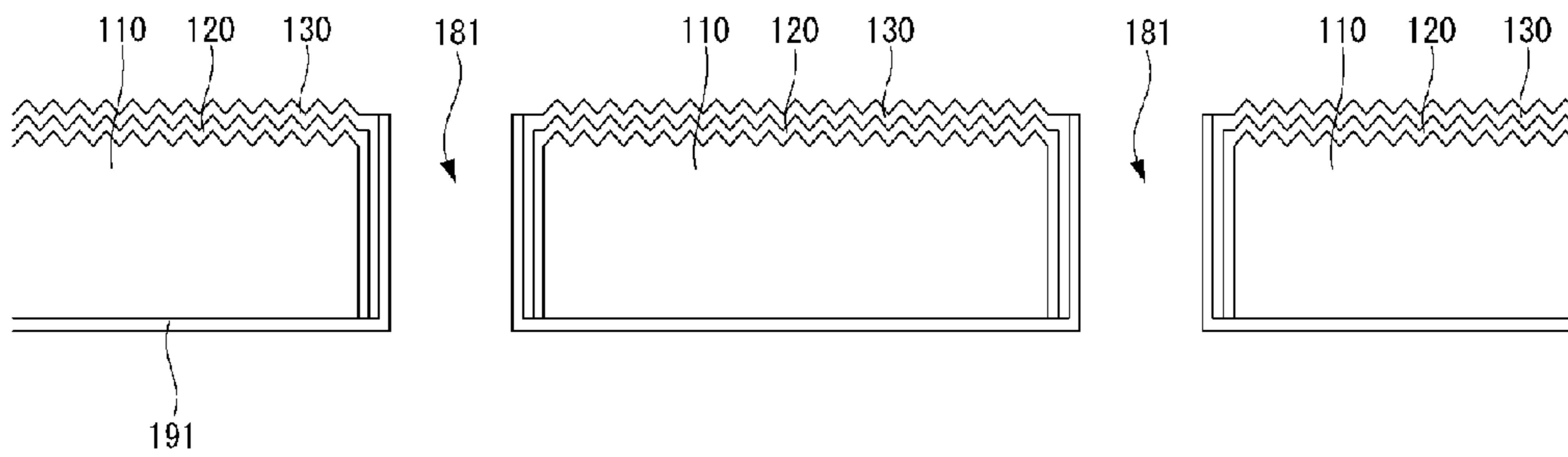

FIG. 3G-9

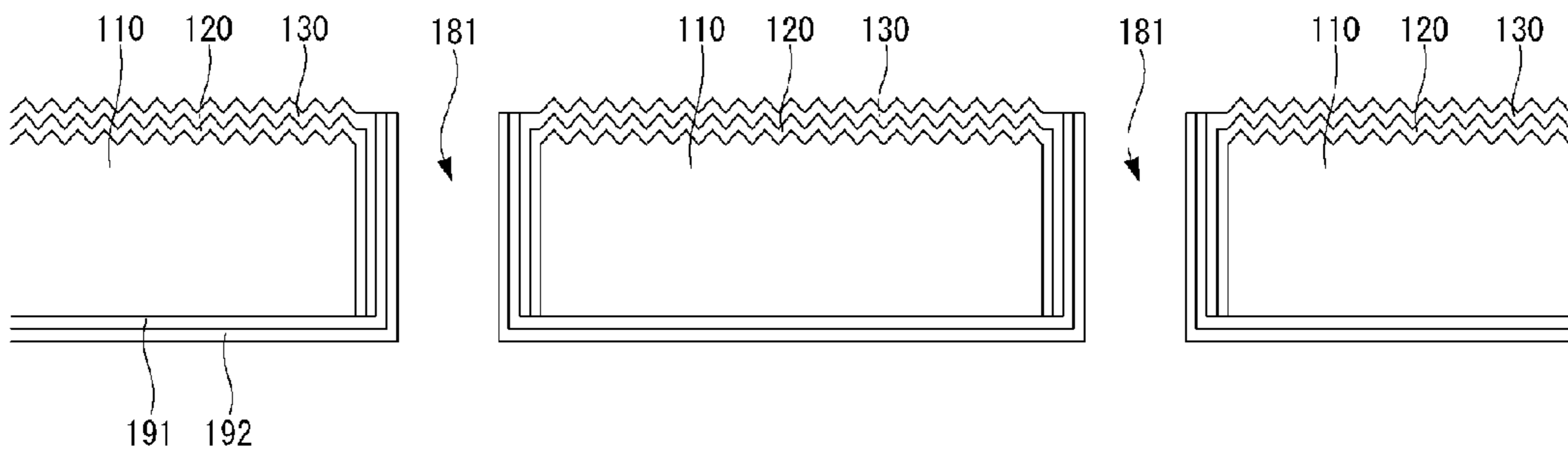

FIG. 3H-10

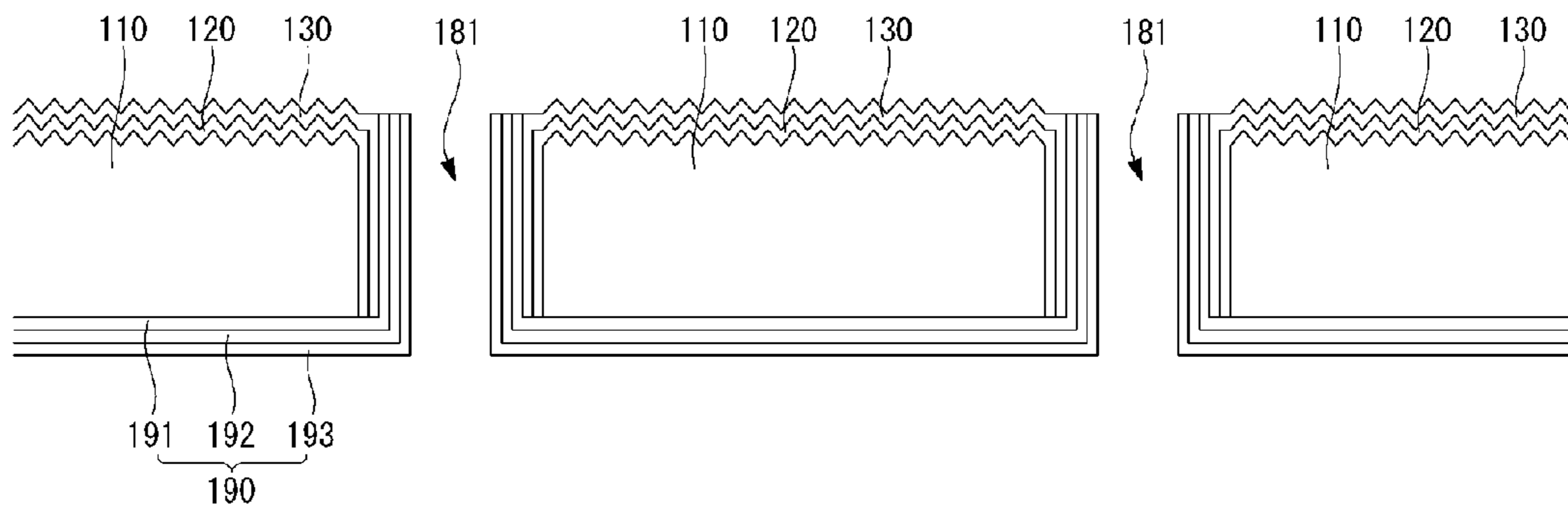

FIG. 3I-11

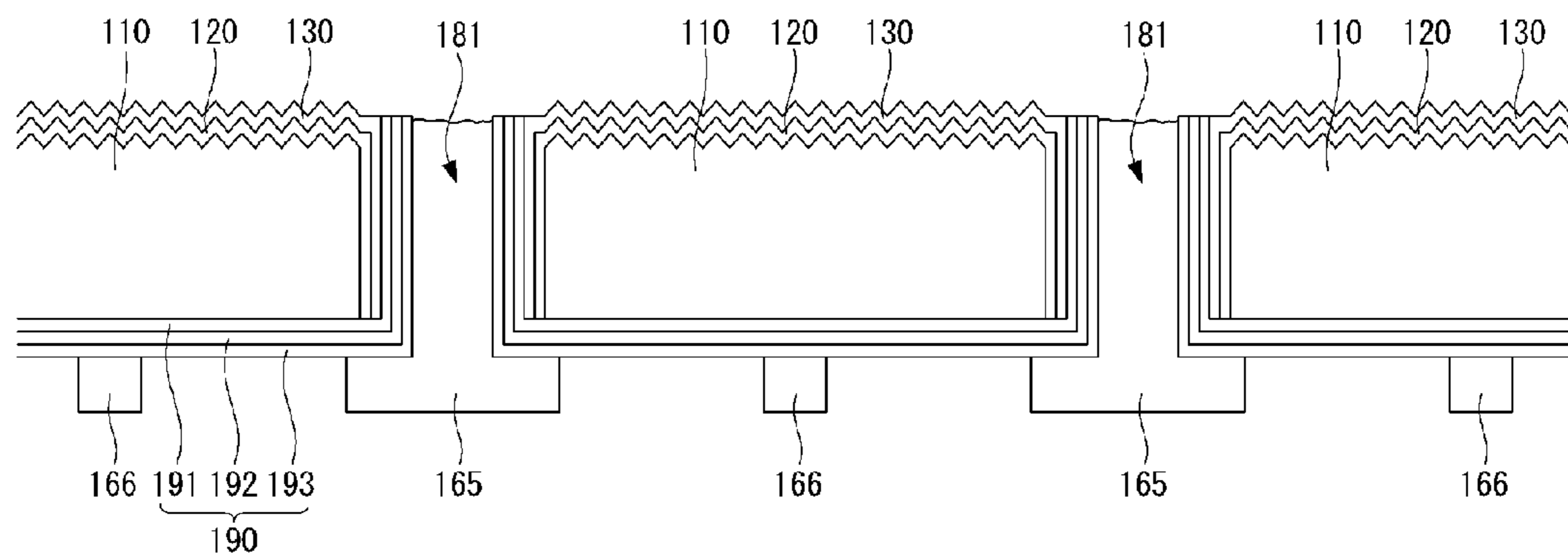

FIG. 3J-12

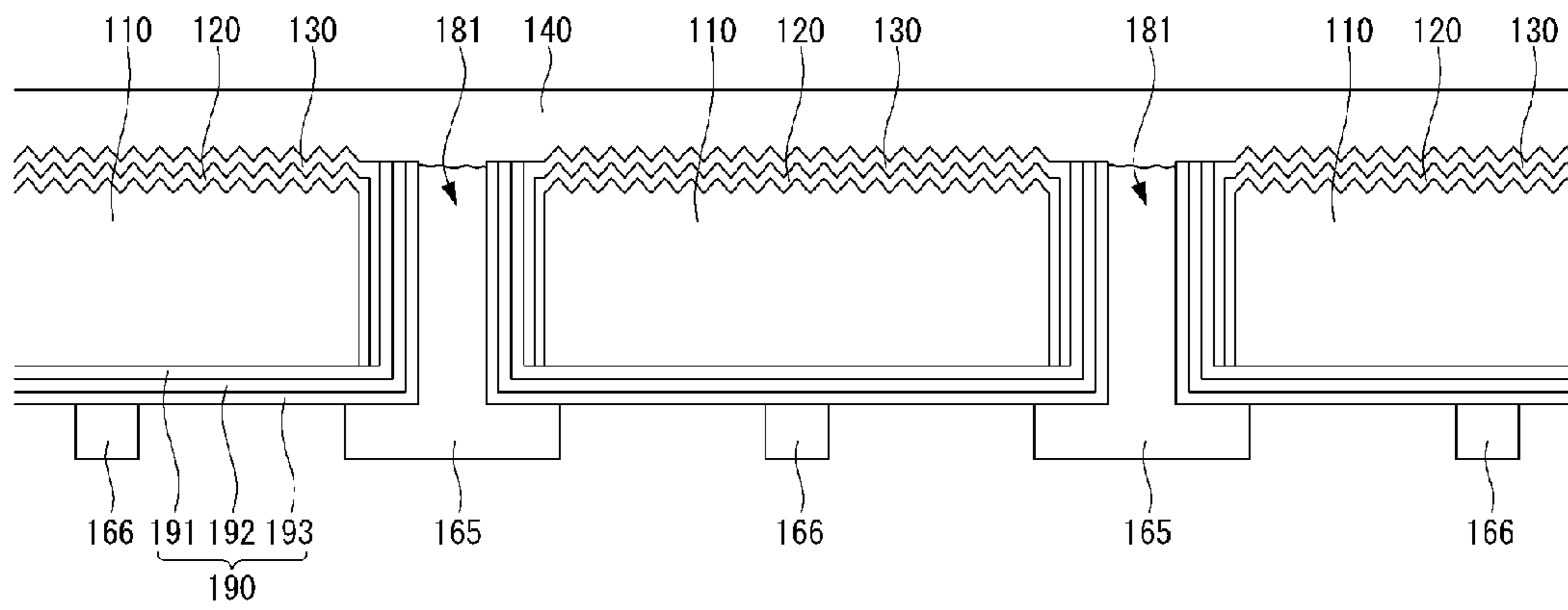

FIG. 3K-13

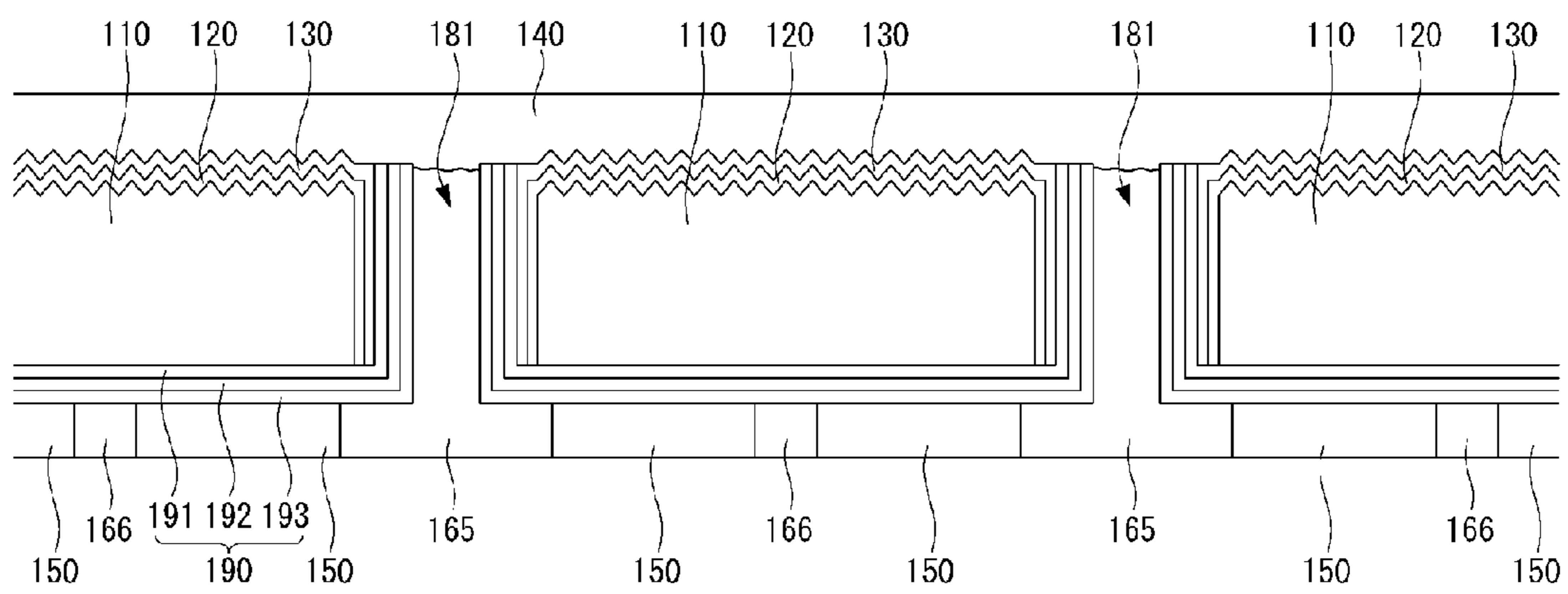

FIG. 3L-14

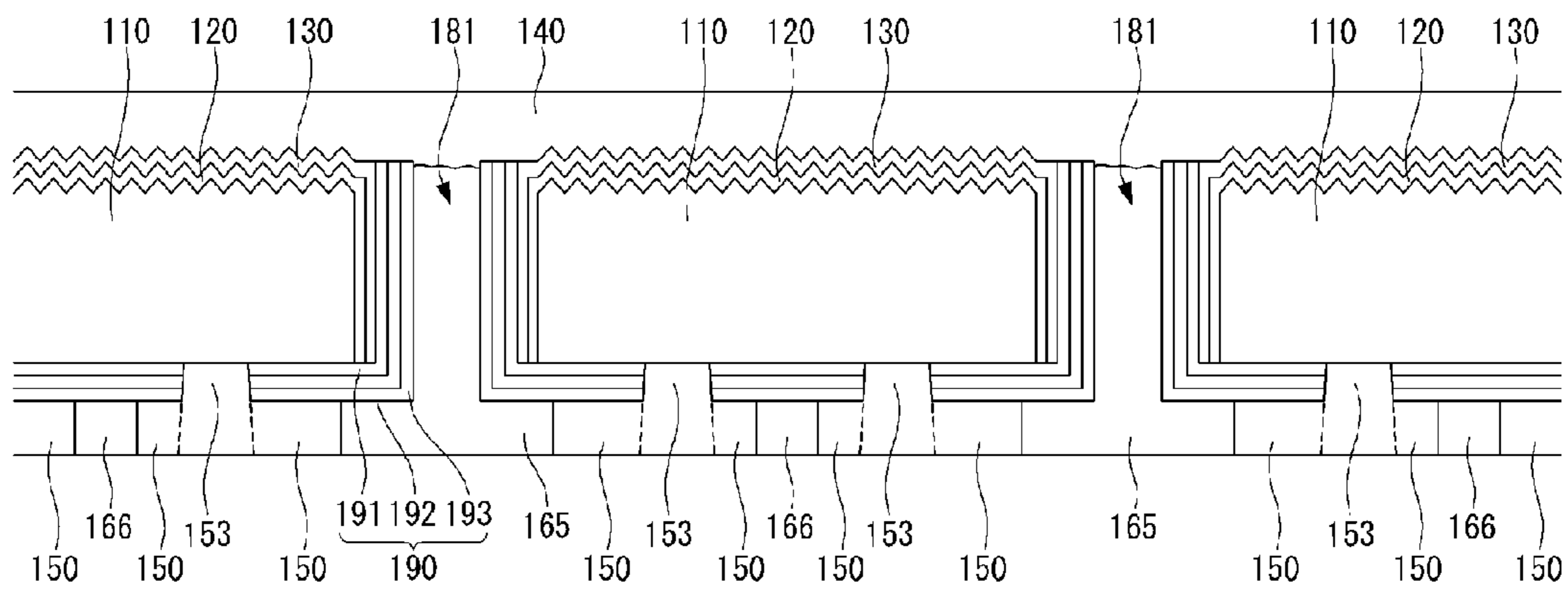

FIG. 3M-15

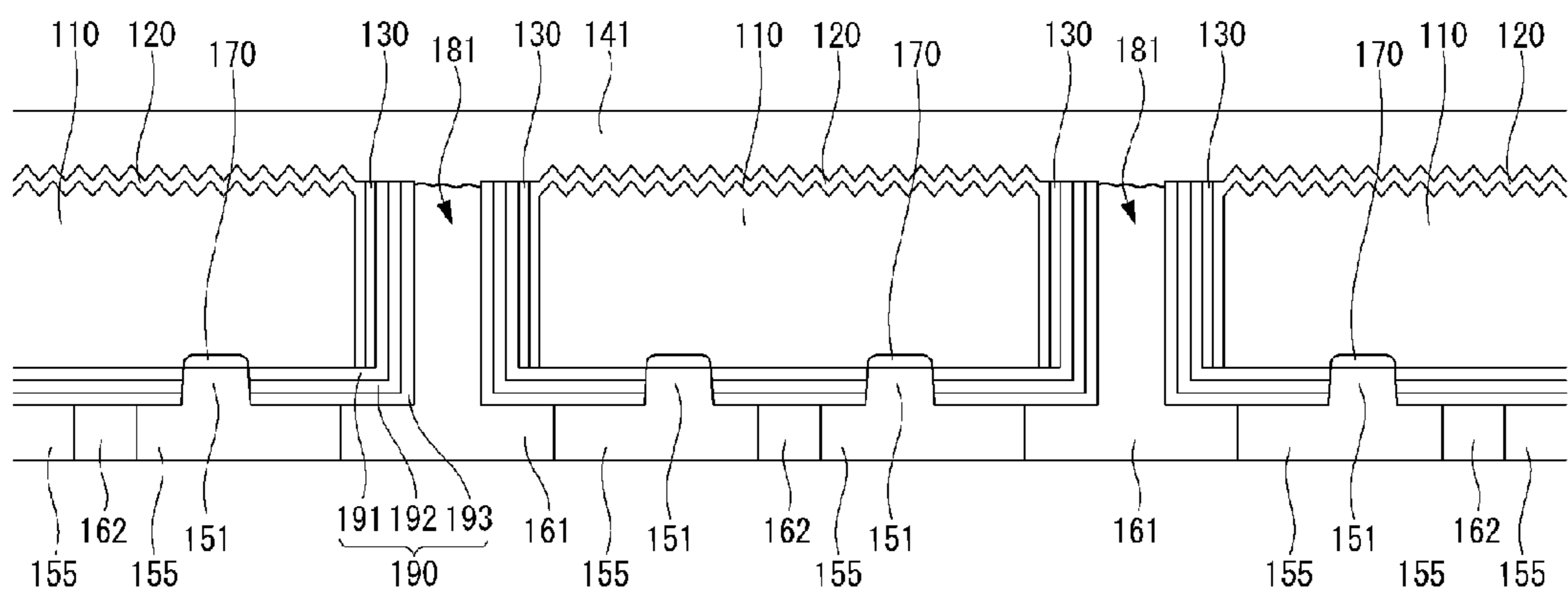

FIG. 4-16

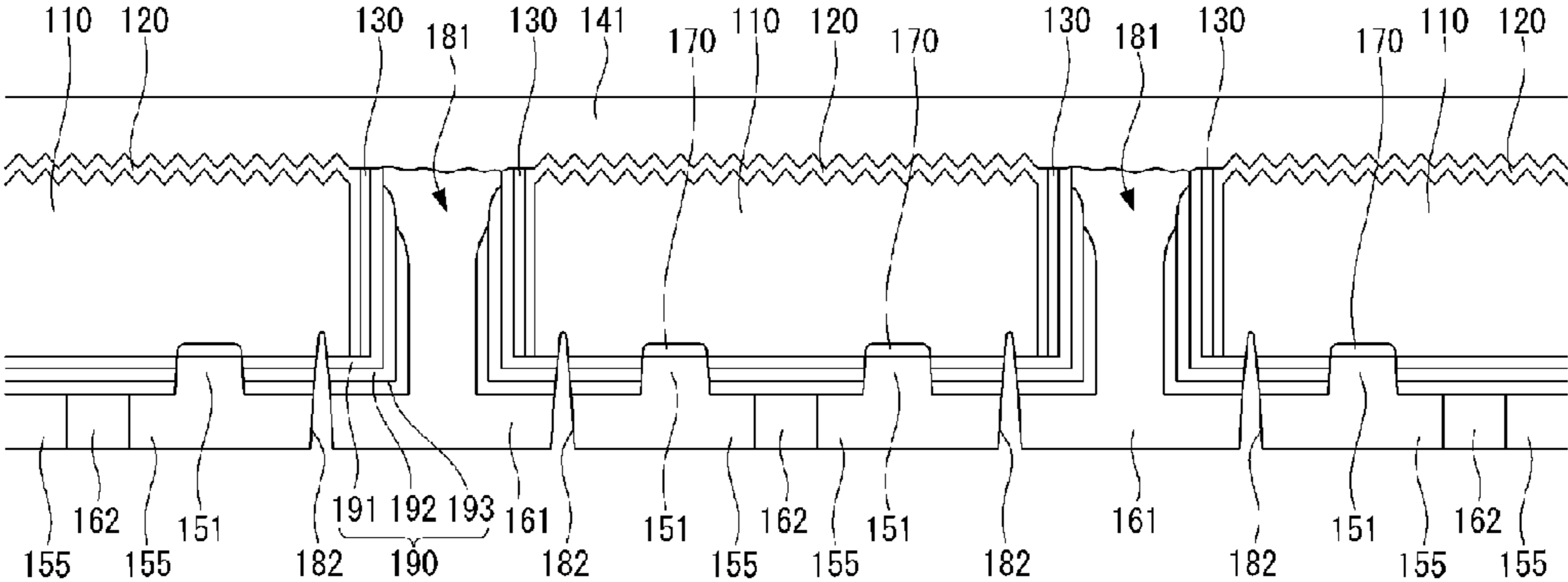
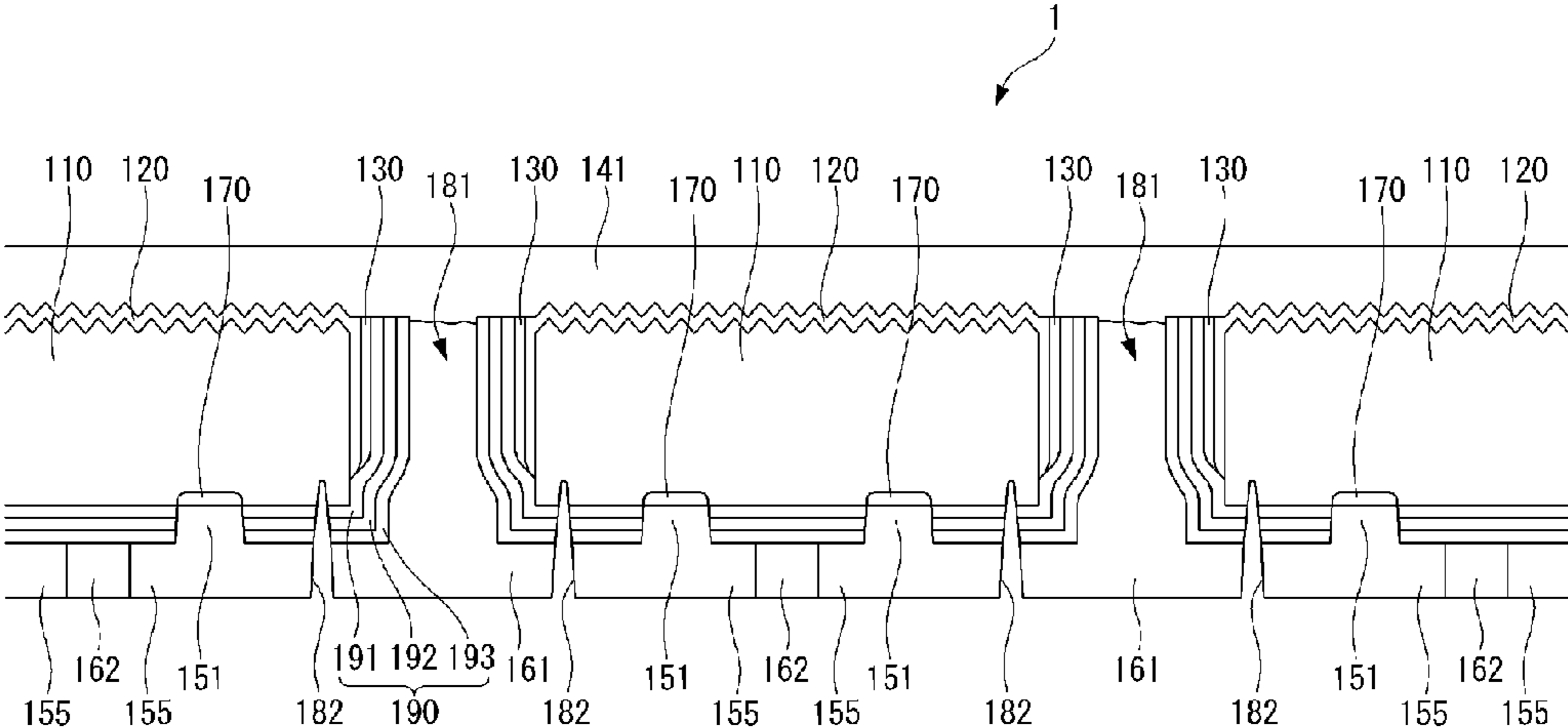

FIG. 5-17



SOLAR CELL AND METHOD OF MANUFACTURING THE SAME

This application is a continuation of U.S. application Ser. No. 12/559,542, filed on Sep. 15, 2009 now U.S. Pat. No. 8,203,072, which claims priority to and the benefit of Korean Patent Application No. 10-2009-0055379 filed in the Republic of Korea on Jun. 22, 2009. The entire contents of all of the above applications are hereby incorporated by reference.

BACKGROUND OF THE INVENTION

1. Field of the Invention

Embodiments relate to a solar cell and a method of manufacturing the same.

2. Description of the Related Art

Recently, as existing energy sources such as petroleum and coal are expected to be depleted, interests in alternative energy sources for replacing the existing energy sources are increasing. Among the alternative energy sources, solar cells have been particularly spotlighted because, as cells for generating electric energy from solar energy, the solar cells are able to draw energy from an abundant source and do not cause environmental pollution.

A general solar cell includes a substrate and an emitter layer, formed of a semiconductor, each having a different conductive type such as a p-type and an n-type, and electrodes respectively formed on the substrate and the emitter layer. The general solar cell also includes a p-n junction formed at an interface between the substrate and the emitter layer.

When light is incident on the solar cell, a plurality of electron-hole pairs are generated in the semiconductor. Each of the electron-hole pairs is separated into electrons and holes by the photovoltaic effect. Thus, the separated electrons move to the n-type semiconductor (e.g., the emitter layer) and the separated holes move to the p-type semiconductor (e.g., the substrate), and then the electrons and holes are collected by the electrodes electrically connected to the emitter layer and the substrate, respectively. The electrodes are connected to each other using electric wires to thereby obtain an electric power.

At least one current collector like a bus bar is positioned on each of the emitter layer and the substrate, and the current collector on the emitter layer and the current collector on the substrate are connected to the corresponding electrodes, respectively. Hence, charges collected by the electrode easily move to a load connected to the outside through the current collector adjacent to the electrode.

However, in this case, because the current collectors are respectively formed on one surface of the substrate on which the light is not incident and the other surface of the substrate on which the light is incident (i.e., the emitter layer on an incident surface of the substrate), an incident area of the light is reduced. Hence, the efficiency of the solar cell is reduced.

Accordingly, a metal wrap through (MWT) solar cell was developed so as to prevent a reduction in the efficiency of the solar cell resulting from the current collectors. In the MWT solar cell, a current collector connected to an emitter layer was positioned on a rear surface of a substrate opposite an incident surface of the substrate.

SUMMARY OF THE INVENTION

Embodiments provide a solar cell and a method of manufacturing the same capable of improving an efficiency of the solar cell.

In one aspect there is a solar cell including a substrate of a first conductive type having at least one via hole; an emitter layer only on at least a portion of the at least one via hole and at least one selected from a group consisting of an incident surface and side surfaces of the substrate, the emitter layer having a second conductive type opposite the first conductive type; at least one first electrode on the incident surface of the substrate, the first electrode being electrically connected to the emitter layer; a second electrode connected to an opposite surface to the incident surface of the substrate; and at least one first electrode current collector on the opposite surface, the at least one first electrode current collector being insulated from the second electrode and being electrically connected to the at least one first electrode through the at least one via hole.

In another aspect, there is a method of manufacturing a solar cell including forming at least one via hole on a substrate of a first conductive type; forming an emitter layer of a second conductive type opposite the first conductive type only on at least a portion of the at least one via hole and at least one selected from a group consisting of an incident surface and side surfaces of the substrate; and forming a plurality of first electrodes electrically connected to the emitter layer, a first electrode current collector electrically connected to the first electrodes through the at least one via hole, a second electrode that is positioned on the substrate, and a second electrode current collector that is electrically connected to the second electrode.

Further scope of applicability of the present invention will become apparent from the detailed description given hereinafter. However, it should be understood that the detailed description and specific examples, while indicating preferred embodiments of the invention, are given by illustration only, since various changes and modifications within the spirit and scope of the invention will become apparent to those skilled in the art from this detailed description.

BRIEF DESCRIPTION OF THE DRAWINGS

The accompanying drawings, which are included to provide a further understanding of the invention and are incorporated in and constitute a part of this specification, illustrate embodiments of the invention and together with the description serve to explain the principles of the invention. In the drawings:

FIG. 1 is a partial perspective view of a solar cell according to an example embodiment;

FIG. 2 is a cross-sectional view taken along the line II-II of FIG. 1;

FIGS. 3A to 3M are cross-sectional views sequentially illustrating each of stages in a method of manufacturing a solar cell according to an example embodiment;

FIG. 4 is another cross-sectional view of a solar cell taken along the line II-II of FIG. 1; and

FIG. 5 is another cross-sectional view of a solar cell taken along the line II-II of FIG. 1.

DETAILED DESCRIPTION OF THE EMBODIMENTS

The invention will be described more fully hereinafter with reference to the accompanying drawings, in which example embodiments of the inventions are shown. This invention may, however, be embodied in many different forms and should not be construed as limited to the embodiments set forth herein.

In the drawings, the thickness of layers, films, panels, regions, etc., are exaggerated for clarity. Like reference

numerals designate like elements throughout the specification. It will be understood that when an element such as a layer, film, region, or substrate is referred to as being “on” another element, it can be directly on the other element or intervening elements may also be present. In contrast, when an element is referred to as being “directly on” another element, there are no intervening elements present.

FIG. 1 is a partial perspective view of a solar cell according to an example embodiment. FIG. 2 is a cross-sectional view taken along line II-II of FIG. 1. As shown in FIG. 1, a solar cell 1 according to an embodiment includes a substrate 110 having a plurality of via holes 181, an emitter layer 120 on the substrate 110, an anti-reflection layer 130, a passivation layer 190, a plurality of front electrodes 141, a rear electrode conductive layer 155, a plurality of front electrode current collectors 161 connected to the front electrodes 141, a plurality of rear electrode current collectors 162, and a plurality of back surface field (BSF) layers 170. The anti-reflection layer 130 is positioned on an incident surface (hereinafter, referred to as “a front surface”) of the substrate 110, on which light is incident, and on the emitter layer 120 inside the via hole 181. The passivation layer 190 is positioned on a rear surface (also referred to as an opposite surface), opposite the front surface of the substrate 110, on which the light is not incident, and at a side wall of each of the via holes 181. The front electrodes 141 are formed on a portion of the front surface of the substrate 110. The rear electrode conductive layer 155 is positioned on the passivation layer 190 and includes a plurality of rear electrodes 151 electrically connected to the substrate 110. The rear electrode current collectors 162 are connected to the rear electrodes 151 through the rear electrode conductive layer 155. The BSF layers 170 are positioned between the substrate 110 and the rear electrodes 151.

In the example embodiment, the substrate 110 may be formed of silicon doped with impurities of a first conductive type, for example, a p-type, though not required. Examples of silicon include single crystal silicon, polycrystalline silicon, and amorphous silicon. When the substrate 110 is of a p-type, the substrate 110 contains impurities of a group III element such as boron (B), gallium (Ga), and Indium (In). Alternatively, the substrate 110 may be of an n-type, and/or be made of other materials than silicon. When the substrate 110 is of the n-type, the substrate 110 may contain impurities of a group V element such as phosphor (P), arsenic (As), and antimony (Sb).

The surface of the substrate 110 is textured to form a textured surface corresponding to an uneven surface. The plurality of via holes 181 passing through the substrate 110 are formed at each of crossings of the front electrodes 141 and the front electrode current collectors 161.

The emitter layer 120 is an impurity portion having a second conductive type (for example, an n-type) opposite the first conductive type of the substrate 110. The emitter layer 120 and the substrate 110 form a p-n junction.

A plurality of electron-hole pairs produced by light incident on the substrate 110 are separated into electrons and holes by a built-in potential difference resulting from the p-n junction. Then, the separated electrons move toward the n-type semiconductor, and the separated holes move toward the p-type semiconductor. Thus, when the substrate 110 is of the p-type and the emitter layer 120 is of the n-type, the separated holes and the separated electrons move toward the substrate 110 and the emitter layer 120, respectively. Accordingly, the holes in the substrate 110 and the electrons in the emitter layer 120 become major carriers.

Because the substrate 110 and the emitter layer 120 form the p-n junction, the emitter layer 120 may be of the p-type

when the substrate 110 is of the n-type unlike the embodiment described above. In this case, the separated electrons and the separated holes move toward the substrate 110 and the emitter layer 120, respectively.

Returning to the embodiment when the emitter layer 120 is of the n-type, the emitter layer 120 may be formed by doping the substrate 110 with impurities of a group V element such as P, As, and Sb. On the contrary, when the emitter layer 120 is of the p-type, the emitter layer 120 may be formed by doping the substrate 110 with impurities of a group III element such as B, Ga, and In.

The anti-reflection layer 130 formed of silicon nitride (SiNx) and/or silicon oxide (SiO_x) is positioned on the emitter layer 120 positioned on the front surface of the substrate 110 and at the side wall of the via hole 181. The anti-reflection layer 130 reduces a reflectance of light incident on the substrate 110 and increases a selectivity of a predetermined wavelength band, thereby increasing the efficiency of the solar cell 1. The anti-reflection layer 130 may have a thickness of about 80 nm to 100 nm. Alternatively, the anti-reflection layer 130 may be positioned at only the side wall of each of the via holes 181. The anti-reflection layer 304 may be omitted, if desired.

Although it is not shown in FIGS. 1 and 2, the anti-reflection layer 130 and the emitter layer 120 each have an exposing portion (not shown) exposing a portion of an edge of the front surface of the substrate 110, so as to implement an edge isolation of the substrate 110.

The passivation layer 190 is positioned on the rear surface of the substrate 110 and on the anti-reflection layer 130 positioned at the side wall of each of the via holes 181. The passivation layer 190 reduces a recombination of charges around the surface of the substrate 110 and increases an inner reflectance of light passing through the substrate 110 to thereby increase a re-incidence of the light passing through the substrate 110.

The passivation layer 190 has a three-layered structure including a first passivation layer 191 formed of silicon oxide (SiO_x), a second passivation layer 192 formed of silicon nitride (SiNx) on the first passivation layer 191, and a third passivation layer 193 formed of silicon oxynitrides (SiO_xN_y) on the second passivation layer 192. Other materials may be used for each of the first to third passivation layers 191 to 193.

The first and second passivation layers 191 and 192 change an unstable bond, like a dangling bond, existing around the surface of the substrate 110 into a stable bond to reduce a recombination and/or a disappearance between charges (for example, holes) moving to the substrate 110 and an unstable bond. The third passivation layer 193 protects the first and second passivation layers 191 and 192 from the rear electrode conductive layer 155. The first to third passivation layers 191 to 193 reflect incident light passing through the substrate 110 back to the substrate 110 to increase an inner reflectance of the solar cell 1.

A thickness and a refractive index of each of the first to third passivation layers 191 to 193 may be properly adjusted, so that the first to third passivation layers 191 to 193 perform the above-described operations. For example, the first and third passivation layers 191 and 193 may have the substantially same thickness, such as, a thickness of about 200 nm, and a thickness of the second passivation layer 192 may have a thickness of about 20 nm less than the thickness of the first and third passivation layers 191 and 193, for example. Further, refractive indexes of the second and third passivation layers 192 and 193 may be greater than a refractive index of the first passivation layer 191. In the embodiment, the second passivation layer 192 have a maximum refractive index, and

the first passivation layer **191** has a minimum refractive index. However, the thickness and the refractive index of each of the first to third passivation layers **191** to **193** may vary depending on a material, a function, a formation method, etc., of the first to third passivation layers **191** to **193**.

In the embodiment, the passivation layer **190** has the three-layered structure including the first to third passivation layers **191** to **193**, but is not limited thereto. The number of layers constituting the passivation layer **190** may vary.

In the embodiment, the first passivation layer **191**, the second passivation layer **192**, and the passivation layer **193** are sequentially formed on the substrate **110** in the order named, but is not limited thereto. A stacking order of the first to third passivation layers **191** to **193** on the substrate **110** may vary. At least one of the first to third passivation layers **191** to **193** may be formed of amorphous silicon. For example, if the first passivation layer **191** is formed of amorphous silicon, the first passivation layer **191** efficiently inactivates an unstable bond to greatly reduce a recombination of charges on the surface of the substrate **110**.

In the embodiment, because the anti-reflection layer **130** and the passivation layer **190** are positioned at the side wall of the via hole **181**, the total number of layers formed at the side wall of the via hole **181** may be 2 to 4.

The front electrodes **141** are positioned on the emitter layer **120** formed on the front surface of the substrate **110**. In addition, the front electrodes **141** are electrically connected to the emitter layer **120** and extend in a fixed direction to be spaced apart from one another. The front electrodes **141** collect charges (for example, electrons) moving to the emitter layer **120** and transfer the collected charges to the front electrode current collectors **161** through the via holes **181**. The front electrodes **141** are formed of at least one conductive metal material. More specifically, the front electrodes **141** may be formed of at least one selected from a group consisting of nickel (Ni), copper (Cu), silver (Ag), aluminum (Al), tin (Sn), zinc (Zn), indium (In), titanium (Ti), gold (Au), and a combination thereof. Other conductive metal materials may be used.

The rear electrode conductive layer **155** is formed of a conductive metal material and is positioned on the passivation layer **190**. A plurality of exposing portions **182** exposing a portion of the substrate **110** around the front electrode current collectors **161** are formed in the rear electrode conductive layer **155**, the front electrode current collectors **161**, and/or the passivation layer **190**.

The rear electrodes **151** are formed by the rear electrode conductive layer **155** contacting a portion of the rear surface of the substrate **110** passing through the passivation layer **190**. An electrical connection between the rear electrodes **151** and the front electrode current collectors **161** is cut off due to the exposing portions **182**.

The rear electrodes **151** are spaced apart from one another at a constant distance and are electrically connected to the substrate **110**. The rear electrodes **151** may have various shapes such as a circle, an oval, and/or a polygon. In addition, the rear electrodes **151** may have the same stripe shape as the front electrode **141**, and thus the rear electrodes **151** are electrically connected to the substrate **110** and extend in one direction. The number of rear electrodes **151** having the stripe shape is much less than the number of rear electrodes **151** having the circle, oval, or polygon shape.

As above, in the embodiment, because the passivation layer **190** is positioned between the substrate **110** and the rear electrode conductive layer **155** and only a portion of the substrate **110** contacts the rear electrodes **151**, a bowing phenomenon of the substrate **110** in the solar cell according to the

embodiment is greatly reduced as compared with a solar cell including rear electrodes contacting an entire surface of a substrate. Hence, a damage of the substrate **110** resulting from the bowing phenomenon is greatly reduced. The rear electrodes **151** collect charges (for example, holes) moving to the substrate **110**.

The rear electrodes **151** are formed of at least one conductive metal material. More specifically, the rear electrodes **151** may be formed of at least one selected from the group consisting of Ni, Cu, Ag, Al, Sn, Zn, In, Ti, Au, and a combination thereof. Other conductive metal materials may be used.

The plurality of front electrode current collectors **161** are positioned in each of the via holes **181** and on the passivation layer **190** positioned around the via holes **181**. The front electrode current collectors **161** extend in a cross direction with respect to the front electrode **141**.

The front electrode current collectors **161** are formed of at least one conductive metal material and are electrically connected to the front electrodes **141** crossing the front electrode current collectors **161** through the via holes **181**. Accordingly, the front electrode current collectors **161** output charges transferred from the front electrodes **141** to an external device. The front electrode current collectors **161** may be formed of at least one selected from the group consisting of Ni, Cu, Ag, Al, Sn, Zn, In, Ti, Au, and a combination thereof. Other conductive metal materials may be used.

The rear electrode current collectors **162** are positioned on the passivation layer **190** and extend parallel to the front electrode current collectors **161**. The rear electrode current collectors **162** collect charges (for example, holes) transferred from the rear electrode **151** through the rear electrode conductive layer **155** to output the collected charges to an external device.

In the embodiment, the rear electrode current collectors **162** have a shape of extending in a fixed direction, similar to the front electrode current collectors **161**. However, the rear electrode current collectors **162** may include a plurality of circle or polygon-shaped conductors that are spaced apart from one another at a constant distance or interval, though not required. The rear electrode current collectors **162** are formed of the same material as the front electrode current collectors **161** and are positioned on the same level layer as the front electrode current collectors **161**.

The plurality of BSF layers **170** are positioned between the rear electrode **151** and the substrate **110**. The BSF layers **170** are areas (for example, a p+-type area) that are more heavily doped with impurities of the same conductive type as the substrate **110** than the substrate **110**. The smooth movement of electrons to the rear surface of the substrate **110** is disturbed by a potential barrier resulting from a difference between impurity doping concentrations of the substrate **110** and the BSF layers **170**. Accordingly, the BSF layers **170** prevent or reduce a recombination and/or a disappearance of the electrons and holes in an interface of the substrate **110** and the rear electrodes **151**.

In the solar cell **1** according to the embodiment having the above-described structure, the front electrode current collectors **161** are positioned on the rear surface of the substrate **110** on which light is not incident, the front electrodes **141** on the front surface of the substrate **110** are electrically connected to the front electrode current collectors **161** using the plurality of via holes **181**, and the passivation layer **190** is formed on the rear surface of the substrate **110** to reduce a contact area between the substrate **110** and the rear electrodes **151**. An operation of the solar cell **1** will be below described in detail.

When light irradiated to the solar cell **1** is incident on the substrate **110** through the anti-reflection layer **130** and the

emitter layer **120**, a plurality of electron-hole pairs are generated in the substrate **110** by light energy based on the incident light. Because the surface of the substrate **110** is a textured surface, a light reflectance in the front surface of the substrate **110** is reduced. Further, because both a light incident operation and a light reflection operation are performed on the textured surface, the light is confined in the solar cell **1**. Hence, a light absorptance increases, and the efficiency of the solar cell **1** is improved. In addition, because a reflection loss of light incident on the substrate **110** is reduced by the anti-reflection layer **130**, an amount of light incident on the substrate **110** further increases.

The electron-hole pairs are separated by the p-n junction of the substrate **110** and the emitter layer **120**, and the separated electrons move to the n-type emitter layer **120** and the separated holes move to the p-type substrate **110**. The electrons moving to the n-type emitter layer **120** are collected by the front electrodes **141** and then are transferred to the front electrode current collectors **161**. The holes moving to the p-type substrate **110** are collected by the rear electrode **151** and then are transferred to the rear electrode current collectors **162**. When the front electrode current collectors **161** are connected to the rear electrode current collectors **162** using electric wires (not shown), current flows therein to thereby enable use of the current for electric power.

In the embodiment, because the front electrode current collectors **161** are positioned on the rear surface of the substrate **110** on which light is not incident, an incident area of light increases and the efficiency of the solar cell **1** is improved.

In the embodiment, the passivation layer **190** having a multi-layered structure is positioned between the substrate **110** and the rear electrode conductive layer **155**, and the rear electrodes **151** are formed by bringing a portion of the rear electrode conductive layer **155** into contact with the substrate **110**, instead of having the rear electrodes formed on the entire rear surface of the substrate **110**. Hence, in the solar cell **1** according to the embodiment, a contact area between the rear electrodes **151** and the substrate **110** is greatly reduced as compared with a solar cell including a plurality of rear electrodes on an entire rear surface of a substrate. Nevertheless, because the unstable bond on the surface of the substrate **110** changes into an inactive state (or passivated) by the passivation layer **190**, a recombination of charges resulting from the unstable bond on the surface of the substrate **110** is greatly reduced. Accordingly, a use efficiency of light having a long wavelength is improved, and the efficiency of the solar cell **1** is improved.

FIGS. **3A** to **3M** are cross-sectional views sequentially illustrating each of stages in a method of manufacturing a solar cell according to an example embodiment. As shown in FIG. **3A**, a plurality of via holes **181** are formed on a substrate **110** formed of p-type single crystal silicon or p-type polycrystalline silicon. The via holes **181** are formed through a laser drilling method using a laser beam. Other methods may be used for forming the via holes **181**.

As shown in FIG. **3B**, a texturing process is performed on the entire surface of the substrate **110** to form a textured surface of the substrate **110**. However, a side wall of each of the via holes **181** need not have the textured surface, though such may be optional. When the substrate **110** is formed of p-type single crystal silicon, the texturing process is performed using a basic solution such as KOH, NaOH, and tetramethylammonium hydroxide (TMAH). When the substrate **110** is formed of p-type polycrystalline silicon, the texturing process is performed using an acid solution such as HF and HNO₃.

As shown in FIG. **3C**, a high temperature thermal process of a material (for example, POCl₃ or H₃PO₄) containing impurities of a group V element such as P, As, and Sb is performed on the substrate **110** to distribute the group V element impurities on the substrate **110**. Hence, an emitter layer **120** is formed on the entire surface of the substrate **110** including a front surface, a rear surface, and an inner surface of the substrate **110** and/or a side surface (or side walls) of each of the via holes **181**. Unlike the embodiment, when the substrate **110** is of an n-type, a high temperature thermal process of a material (for example, B₂H₆) containing group III element impurities is performed on the substrate **110** or the material containing the group III element impurities is stacked on the substrate **110** to form the p-type emitter layer **120** on the entire surface of the substrate **110**. Then, phosphorous silicate glass (PSG) containing phosphor (P) or boron silicate glass (BSG) containing boron (B) produced when p-type impurities or n-type impurities are distributed inside the substrate **110** are removed through an etching process.

As shown in FIG. **3D**, an anti-reflection layer **130** is formed on the front surface of the substrate **110** and at the side wall of each of the via holes **181** using a chemical vapor deposition (CVD) method such as a plasma enhanced chemical vapor deposition (PECVD) method. In addition, the anti-reflection layer **130** may be formed inside the via holes **181**.

As shown in FIG. **3E**, a portion of the rear surface of the substrate **110** is removed using a wet or dry etching method, and thus a portion of the emitter layer **120** on the rear surface of the substrate **110** is removed. In this case, the emitter layer **120** and/or anti-reflection layer **130** formed at the side wall of the via holes **181** may be partially removed.

Alternatively, a removing operation for the portion of the rear surface of the substrate **110** may be avoided or omitted if the emitter layer is not formed on the rear surface of the substrate **110**. That is, instead of forming the emitter layer **120** over the entire surface of the substrate **110**, including the rear surface of the substrate **110**, as shown in FIG. **3C**, forming of the emitter layer **120** on the rear surface of the substrate **110** may be avoided or omitted by using a mask or a barrier layer on the rear surface of the substrate **110**. The mask or the barrier layer then may be removed, for example, by a separate etching operation.

As shown in FIGS. **3F** to **3H**, a first passivation layer **191** formed of silicon oxide (SiO_x), a second passivation layer **192** formed of silicon nitride (SiN_x), and a third passivation layer **193** formed of silicon oxynitride (SiO_xN_y) are sequentially formed on the rear surface of the substrate **110** in the order named using the CVD method such as the PECVD method to complete a passivation layer **190**. The first and third passivation layers **191** and **193** each have a thickness of about 200 nm, and the second passivation layer **192** has a thickness of about 20 nm. In forming the passivation layer **190**, such as the first through third passivation layers **191-193**, on the rear surface of the substrate **110**, the passivation layer **190**, such as the first through third passivation layers **191-193**, may also be deposited in the via hole **181** on the side wall thereof, in the same order as on the rear surface, though such is not required. In embodiments, not all of the first through third passivation layers **191-193** may need to be used or required. That is, components of the passivation layer **190** within the via hole **181** or on the side wall of the via hole **181** may be different from components of the passivation layer **190** on the rear surface of the substrate **110**. Accordingly, the passivation layer **190** or components thereof for the via hole

181 and the passivation layer **190** or components thereof for the rear surface of the substrate **110** may be formed together or separately.

As shown in FIG. 3I, a paste containing Ag is coated on a corresponding portion of the substrate **110** using a screen printing method and then is dried at about 120° C. to 200° C. to form a front electrode current collector pattern **165** and a rear electrode current collector pattern **166**.

As shown in FIG. 3J, a paste containing Ag is coated on a corresponding portion using the screen printing method and then is dried to form a front electrode pattern **140**. The Ag-containing paste forming the front electrode current collector pattern **165**, the rear electrode current collector pattern **166**, and the front electrode pattern **140** may include at least one selected from the group consisting of Ni, Cu, Al, Sn, Zn, In, Ti, Au, and a combination thereof, instead of Ag. Other conductive metal materials may be used.

As shown in FIG. 3K, a paste containing Al is coated on a corresponding portion of the substrate **110** using the screen printing method and then is dried to form a rear electrode conductive layer pattern **150**. In this case, the rear electrode conductive layer pattern **150** is formed in a remaining portion excluding a formation portion of the front electrode current collector pattern **165** and the rear electrode current collector pattern **166** from the rear surface of the substrate **110**. In the embodiment, a formation order of the front electrode pattern **140**, the front electrode current collector pattern **165**, the rear electrode current collector pattern **166**, and the rear electrode conductive layer pattern **150** may vary.

As shown in FIG. 3L, a laser beam is irradiated onto a fixed portion of the rear electrode conductive layer pattern **150** to form rear electrode patterns **153** formed of a molten mixture of components of the rear electrode conductive layer pattern **150**, the passivation layer **190**, and the substrate **110**.

A wavelength of the laser beam used may be approximately 355 nm or 532 nm. When the wavelength of the laser beam is approximately 355 nm, an intensity of the laser beam is approximately 1 W. When the wavelength of the laser beam is approximately 532 nm, an intensity of the laser beam is approximately 10 W. The wavelength and the intensity of the laser beam used may vary depending on a thickness and a material of the rear electrode conductive layer pattern **150**, a material and the number of layers of the passivation layer **190**, etc. Further, the number of irradiation operations of the laser beam onto the same portion may vary depending on the thickness and the material of the rear electrode conductive layer pattern **150**, the material and the number of layers of the passivation layer **190**, etc.

As shown in FIG. 3M, the substrate **110** including the front electrode pattern **140**, the front electrode current collector pattern **165**, the rear electrode current collector pattern **166**, and the rear electrode conductive layer pattern **150** is fired at a temperature of about 750° C. to 800° C. to form a plurality of front electrodes **141**, a plurality of front electrode current collectors **161** electrically connected to the front electrodes **141**, a rear electrode conductive layer **155** including a plurality of rear electrodes **151**, and a plurality of BSF layers **171**.

More specifically, when a thermal process is performed, the plurality of front electrodes **141**, that pass through contact portions with the anti-reflection layer **130** and the front electrode pattern **140** and contact the emitter layer **120**, are formed due to elements such as Pb contained in the front electrode pattern **140**. In addition, the rear electrode patterns **153** contact the substrate **110** to form the plurality of rear electrodes **151**. In this case, metal components contained in each of the patterns **140**, **165**, **166**, and **150** chemically

couples with the layers **120** and **110**, and thus a contact resistance is reduced. Hence, a current flow is improved.

Further, when the thermal process is performed, Al contained in the rear electrodes **151** is distributed to the substrate **110** contacting the rear electrodes **151** to form the plurality of BSF layers **171** between the rear electrodes **151** and the substrate **110**. In this case, the BSF layers **171** are an area doped with impurities of the same conductive type as the substrate **110**, for example, p-type impurities. An impurity doping concentration of the BSF layers **171** is greater than an impurity doping concentration of the substrate **110**, and thus the BSF layers **171** are a p+-type area.

In the embodiment, because the anti-reflection layer **130** and the passivation layer **190** are formed at the side wall of each of the via holes **181**, a damage of the emitter layer **120** generated when the high temperature thermal process including the drying and firing operations is performed can be reduced or prevented, and a generation of a leakage current can be reduced or prevented. Further, because the passivation layer **190** has the multi-layered structure, the damage of the emitter layer **120** is further reduced or prevented.

Next, a plurality of exposing portions **182** exposing a portion of the substrate **110** are formed around the front electrode current collectors **161** using a laser beam to electrically separate the rear electrodes **151** electrically connected to the substrate **110** from the front electrode current collectors **161**. The solar cell **1** shown in FIGS. **1** and **2** is completed thereby. Further, before and after the plurality of exposing portions **182** are formed, a portion of the anti-reflection layer **130** formed at an edge of the front surface of the substrate **110** and a portion of the emitter layer **120** underlying the anti-reflection layer **130** are removed to form an exposing portion (not shown) exposing a portion of the front surface of the substrate **110**. Hence, an edge isolation of the substrate **110** is implemented through the exposing portion. In addition, the exposing portions **182** and the exposing portion used in the edge isolation may be formed using a PECVD method instead of the laser beam.

In the solar cell **1** manufactured through the above-described processes, the anti-reflection layer **130** and the passivation layer **190** may be non-uniformly formed at the side wall of the via hole **181** depending on a diameter of the via hole **181**, a diffusion speed, a diffusion distance, a diffusion state, etc. when the anti-reflection layer **130** and the passivation layer **190** are formed. Accordingly, as shown in FIG. **4**, the number of layers formed at the side wall of the via hole **181** may vary depending on a location of the side wall of the via hole **181**. For example, the number of layers formed at the side wall of the via hole **181** increases in a portion adjacent to an injection location of a process gas in a vapor state used to form each of layers constituting the passivation layer **190**. Namely, the number of layers formed at the side wall of the via hole **181** increases as the side wall of the via hole **181** approaches the rear surface of the substrate **110**.

Further, as shown in FIG. **4**, even if the number of layers formed at the side wall of the via hole **181** is constant, a total thickness of layers formed at the side wall of the via hole **181** may vary depending on a the injection location of the process gas, i.e., depending on a distance (i.e., an injection distance) between the injection location of the process gas and the side wall of the via hole **181**. Accordingly, the total thickness of layers formed at the side wall of the via hole **181** increases as the side wall of the via hole **181** approaches the rear surface of the substrate **110** (i.e., as the injection distance becomes shorter). However, in this case, because the side wall of the via hole **181** is protected by the anti-reflection layer **130** and the passivation layer **190** including at least one layer, a generation

11

of a leakage current resulting from the damage of the emitter layer **120** after the thermal process is reduced or prevented. During a fabrication of the solar cell **1** through the processes illustrated in FIGS. **3A** to **3M**, a portion of the substrate **110** may be exposed through the side wall of the via hole **181**.

As shown in FIG. **3E**, when the emitter layer **120** on the rear surface of the substrate **110** is removed, a portion of the anti-reflection layer **130** inside the via hole **181** and a portion of the emitter layer **120** underlying the anti-reflection layer **130** may be removed. Hence, after a removing process of the emitter layer **120** on the rear surface of the substrate **110**, a portion of the substrate **110** may be exposed through the side wall of the via hole **181**. In this case, as the emitter layer **120** and the anti-reflection layer **130** approach the rear surface of the substrate **110**, a probability to remove the emitter layer **120** and the anti-reflection layer **130** inside the via hole **181** together with the emitter layer **120** on the rear surface of the substrate **110** increases. However, in the embodiment, because the passivation layer **190** having the multi-layered structure is positioned at the side wall of the via hole **181**, as shown in FIG. **5**, the portion of the substrate **110** exposed at the side wall of the via hole **181** is covered by the anti-reflection layer **130** in a subsequent process.

As shown in FIG. **4**, because a formation of the passivation layer **190** is easily performed at the rear surface of the substrate **110** having a high removing probability of the emitter layer **120**, the exposed portion of the substrate **110** through at the side wall of the via hole **181** is easily covered by the passivation layer **190**. Accordingly, even if the portion of the emitter layer **120** and the portion of the anti-reflection layer **130** are damaged and the portion of the substrate **110** is exposed at the side wall of the via hole **181**, the exposed portion of the substrate **110** is protected by the passivation layer **190**. Hence, a leakage phenomenon of a current flowing from the front electrode **141** to the front electrode current collector **161** is reduced.

In embodiments of the invention, reference to front or back, with respect to electrode, a surface of the substrate, or others is not limiting. For example, such a reference is for convenience of description since front or back is easily understood as examples of first or second of the electrode, the surface of the substrate or others.

While this invention has been described in connection with what is presently considered to be practical example embodiments, it is to be understood that the invention is not limited to the disclosed embodiments, but, on the contrary, is intended to cover various modifications and equivalent arrangements included within the spirit and scope of the appended claims.

What is claimed is:

1. A solar cell, comprising:

a substrate doped with impurities of a first conductive type and having at least one via hole penetrating the substrate; an emitter layer positioned on a first surface of the substrate, the emitter layer being doped with impurities of a second conductive type opposite the first conductive type;

an anti-reflection layer positioned on the emitter layer on the first surface of the substrate;

at least one first electrode positioned on the emitter layer, the at least one first electrode being directly contacted with the emitter layer;

a passivation layer positioned on a second surface of the substrate opposite the first surface of the substrate, the passivation layer being directly contacted with the second surface of the substrate;

a conductive layer locally positioned on the passivation layer positioned on the second surface of the substrate,

12

the conductive layer having at least one second electrode electrically passing through the passivation layer and locally contacted with the second surface of the substrate; and

at least one first electrode current collector locally positioned on the passivation layer positioned on the second surface of the substrate, the at least one first electrode current collector being separated from the conductive layer and connected to the at least one first electrode through the at least one via hole,

wherein the passivation layer is further positioned on a side wall formed by the substrate in the at least one via hole, the passivation layer is positioned between the at least one first electrode current collector and the side wall formed by the substrate in the at least one via hole,

the passivation layer is extended from the side wall formed by the substrate in the at least one via hole to the second surface of the substrate,

wherein the emitter layer is further positioned on the side wall formed by the substrate in the at least one via hole, and

wherein the anti-reflection layer is further positioned on the side wall formed by the substrate in the at least one via hole.

2. The solar cell of claim **1**, further comprising a back surface field layer positioned on an area in which the at least one second electrode is contacted with the second surface of the substrate, the back surface field layer being doped with impurities of the first conductive type at a greater amount than that of the substrate.

3. The solar cell of claim **1**, wherein the passivation layer is directly contacted with the second surface of the substrate and with the emitter layer passing through the at least one via hole.

4. The solar cell of claim **1**, wherein the conductive layer and the at least one first electrode current collector is spaced apart from each other on the second surface of the substrate.

5. The solar cell of claim **4**, wherein a portion of the passivation layer disposed between the conductive layer and the second surface of the substrate is spaced apart from a portion of the passivation layer disposed between the at least one first electrode current collector and the second surface of the substrate.

6. The solar cell of claim **1**, wherein the passivation layer is further positioned on the anti-reflection layer in the at least one via hole.

7. The solar cell of claim **1**, wherein each of the anti-reflection layer and the passivation layer includes a different material.

8. The solar cell of claim **1**, wherein the passivation layer includes at least one layer containing silicon.

9. The solar cell of claim **1**, wherein the passivation layer includes a first passivation layer positioned on the second surface of the substrate and a second passivation layer positioned on the first passivation layer, and

each of the first and second passivation layers is formed of one of silicon oxide, silicon nitride, silicon oxynitride, and amorphous silicon.

10. The solar cell of claim **9**, wherein a length of the first passivation layer in the at least one via hole is different from a length of the second passivation layer in the at least one via hole.

11. The solar cell of claim **9**, wherein each of the first passivation layer and the second passivation layer includes a different material.

12. The solar cell of claim **9**, wherein each of the first and second passivation layers has a different refractive index.

13. The solar cell of claim **12**, wherein a refractive index of the second passivation layer is greater than a refractive index of the first passivation layer.

14. The solar cell of claim **9**, wherein the passivation layer further includes a third passivation layer positioned on the 5 second passivation layer, and the third passivation layer is formed of one of silicon oxide, silicon nitride, silicon oxynitride, and amorphous silicon.

15. The solar cell of claim **1**, wherein a thickness of the passivation layer formed on the side wall of the at least one via 10 hole is changed depending on a formation location of the passivation layer.

16. The solar cell of claim **1**, further comprising at least one second electrode current collector electrically connected to the second electrode. 15

17. The solar cell of claim **16**, wherein the at least one first electrode current collector and the at least one second electrode current collector are coplanar on the second surface of the substrate.

* * * * *

20