



US008476159B2

(12) **United States Patent**  
**Hsieh**

(10) **Patent No.:** **US 8,476,159 B2**  
(45) **Date of Patent:** **Jul. 2, 2013**

(54) **SUBSTRATE STRUCTURE WITH COMPLIANT BUMP AND MANUFACTURING METHOD THEREOF**

(58) **Field of Classification Search**  
USPC ..... 257/737-738, 780, 784, 786, E23.048;  
438/612-614

(71) Applicant: **Chipbond Technology Corporation,**  
Hsinchu (TW)

See application file for complete search history.

(72) Inventor: **Chin-Tang Hsieh,** Kaohsiung (TW)

(56) **References Cited**

(73) Assignee: **Chipbond Technology Corporation,**  
Hsinchu (TW)

U.S. PATENT DOCUMENTS

7,741,713 B2 \* 6/2010 Satake ..... 257/738  
7,786,582 B2 \* 8/2010 Thomas et al. .... 257/758

(\*) Notice: Subject to any disclaimer, the term of this patent is extended or adjusted under 35 U.S.C. 154(b) by 0 days.

\* cited by examiner

*Primary Examiner* — Theresa T Doan

(21) Appl. No.: **13/644,882**

(74) *Attorney, Agent, or Firm* — Jackson IPG PLLC

(22) Filed: **Oct. 4, 2012**

(65) **Prior Publication Data**

US 2013/0065388 A1 Mar. 14, 2013

(57) **ABSTRACT**

**Related U.S. Application Data**

(62) Division of application No. 13/231,199, filed on Sep. 13, 2011, now Pat. No. 8,426,984.

A substrate structure with compliant bump comprises a substrate, a plurality of bumps, and a metallic layer, wherein the substrate comprises a surface, a trace layer, and a protective layer. The trace layer comprises a plurality of conductive pads, and each of the conductive pads comprises an upper surface. The protective layer comprises a plurality of openings. The bumps are formed on the surface, and each of the bumps comprises a top surface, an inner surface and an outer surface and defines a first body and a second body. The first body is located on the surface. The second body is located on top of the first body. The metallic layer is formed on the top surface, the inner surface, and the upper surface.

(51) **Int. Cl.**  
**H01L 21/44** (2006.01)

(52) **U.S. Cl.**  
USPC ..... **438/612; 257/784; 257/738; 257/780;**  
**257/786; 257/737; 438/613; 438/614**

**2 Claims, 5 Drawing Sheets**

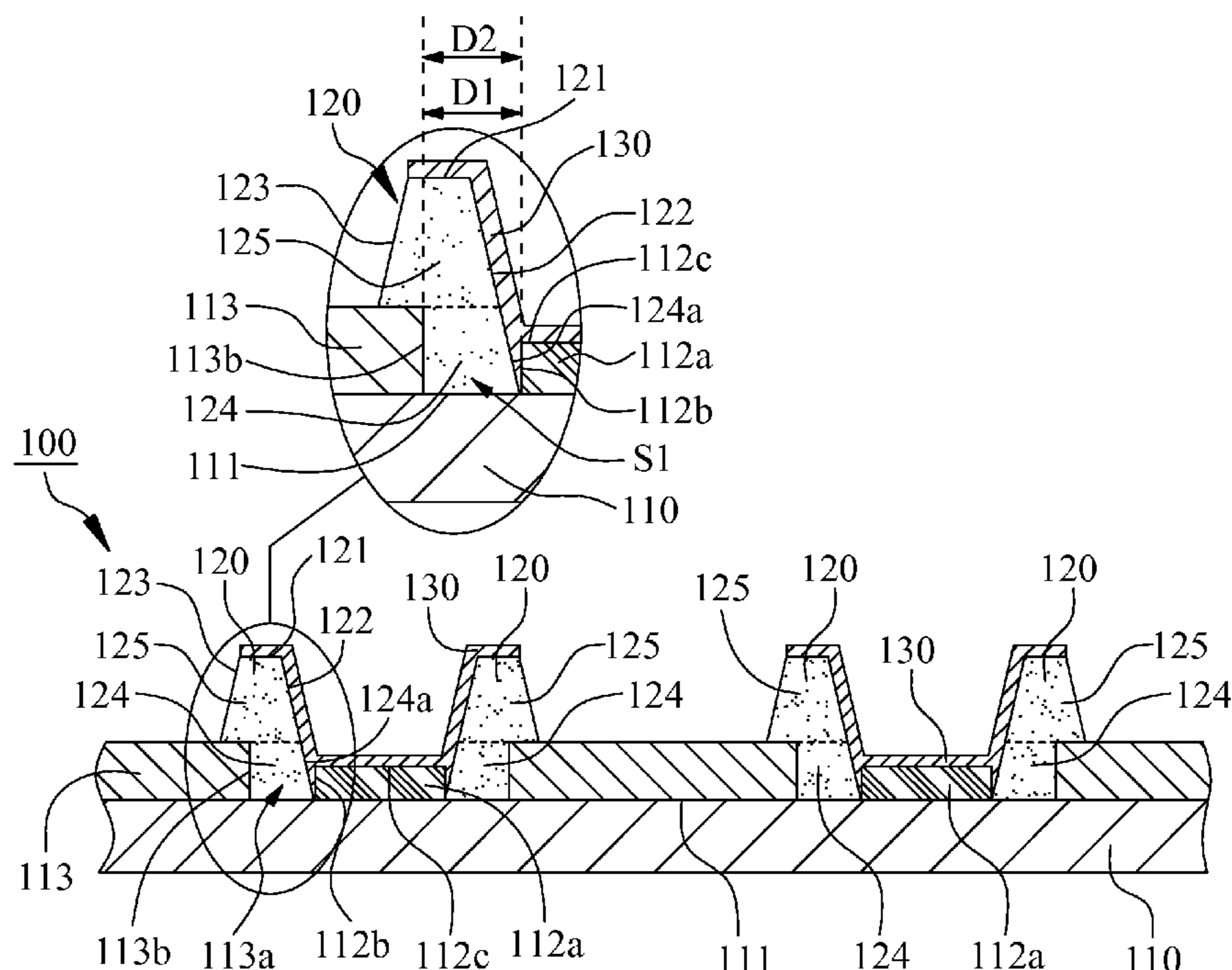

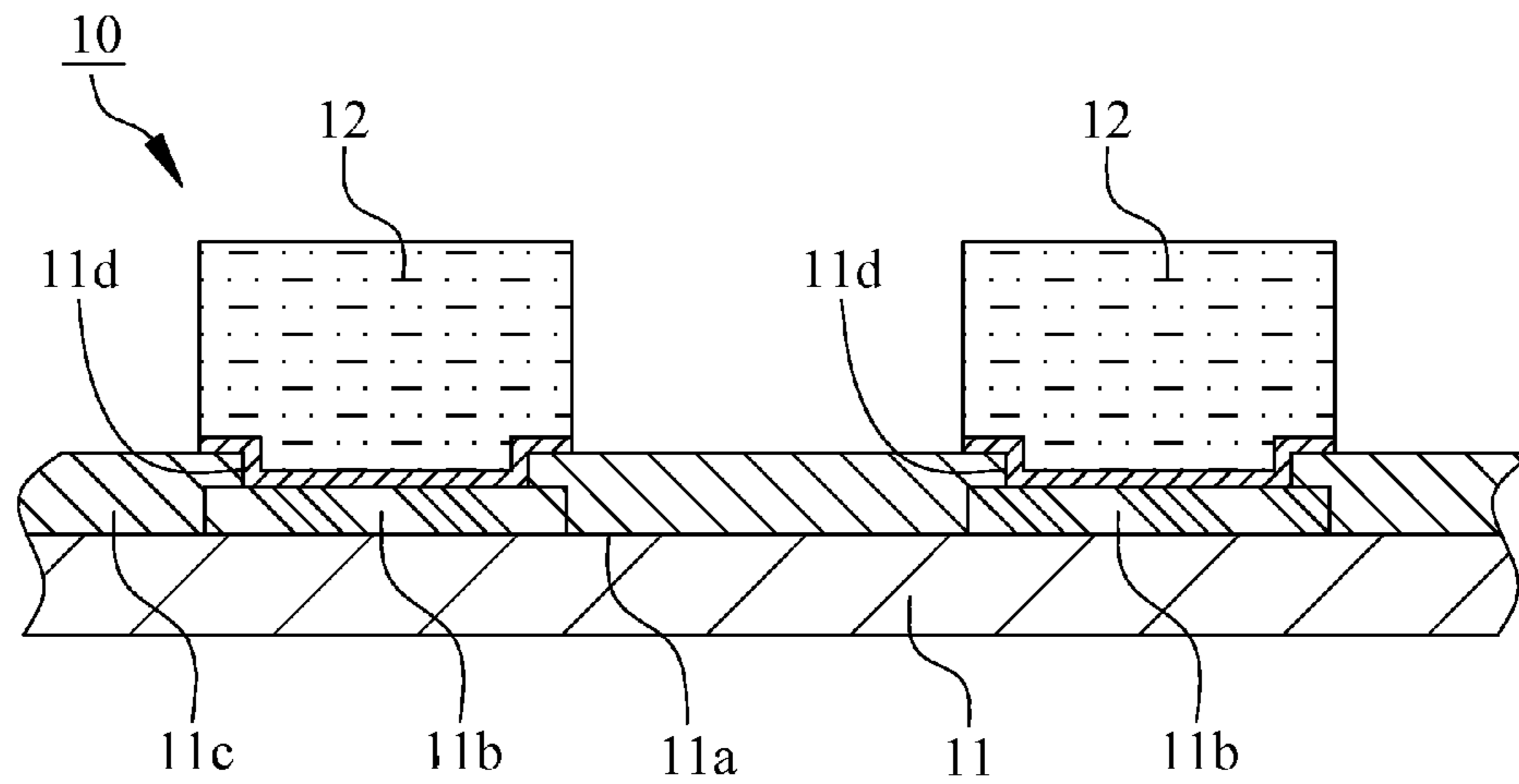

FIG. 1  
PRIOR ART

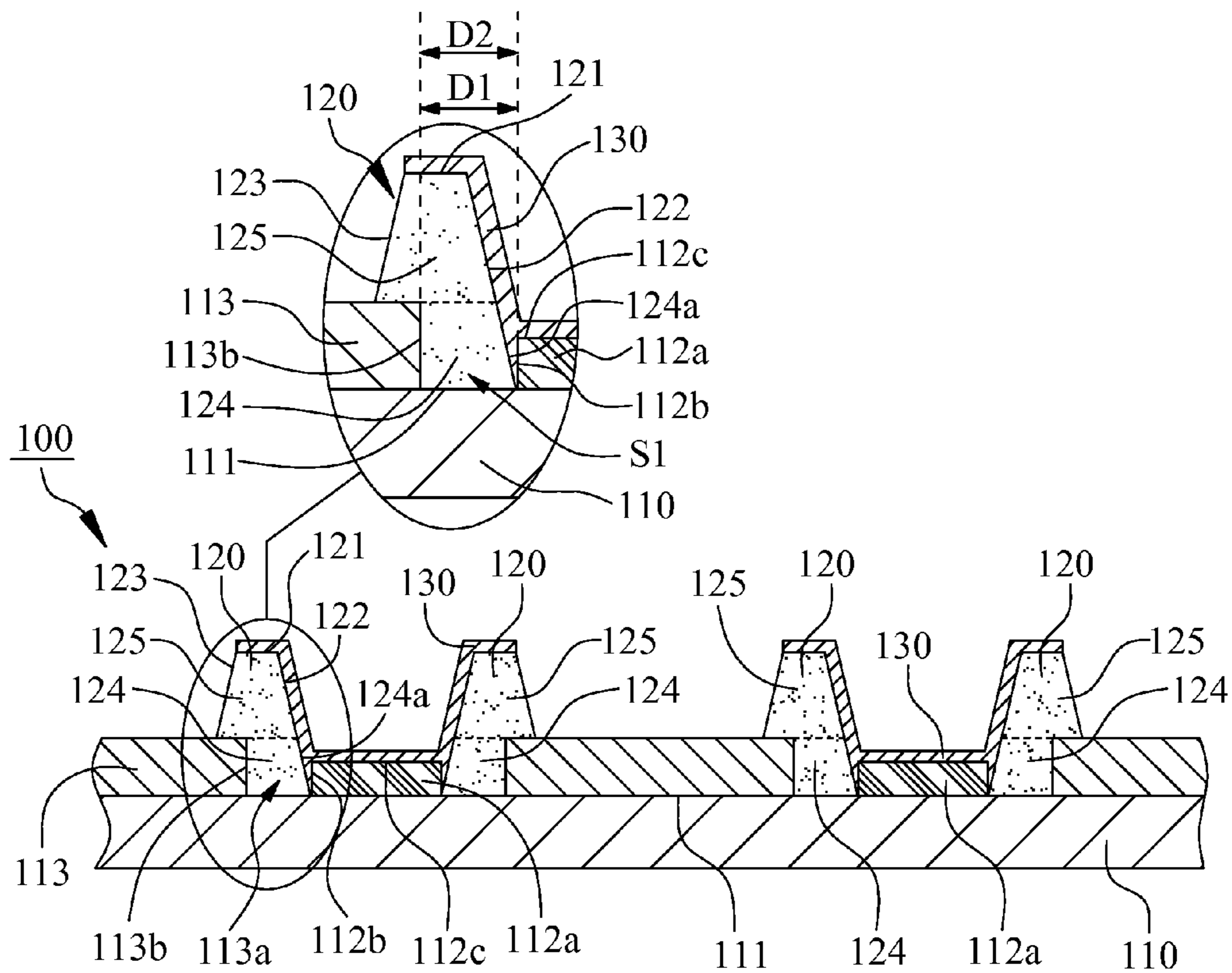

FIG. 2

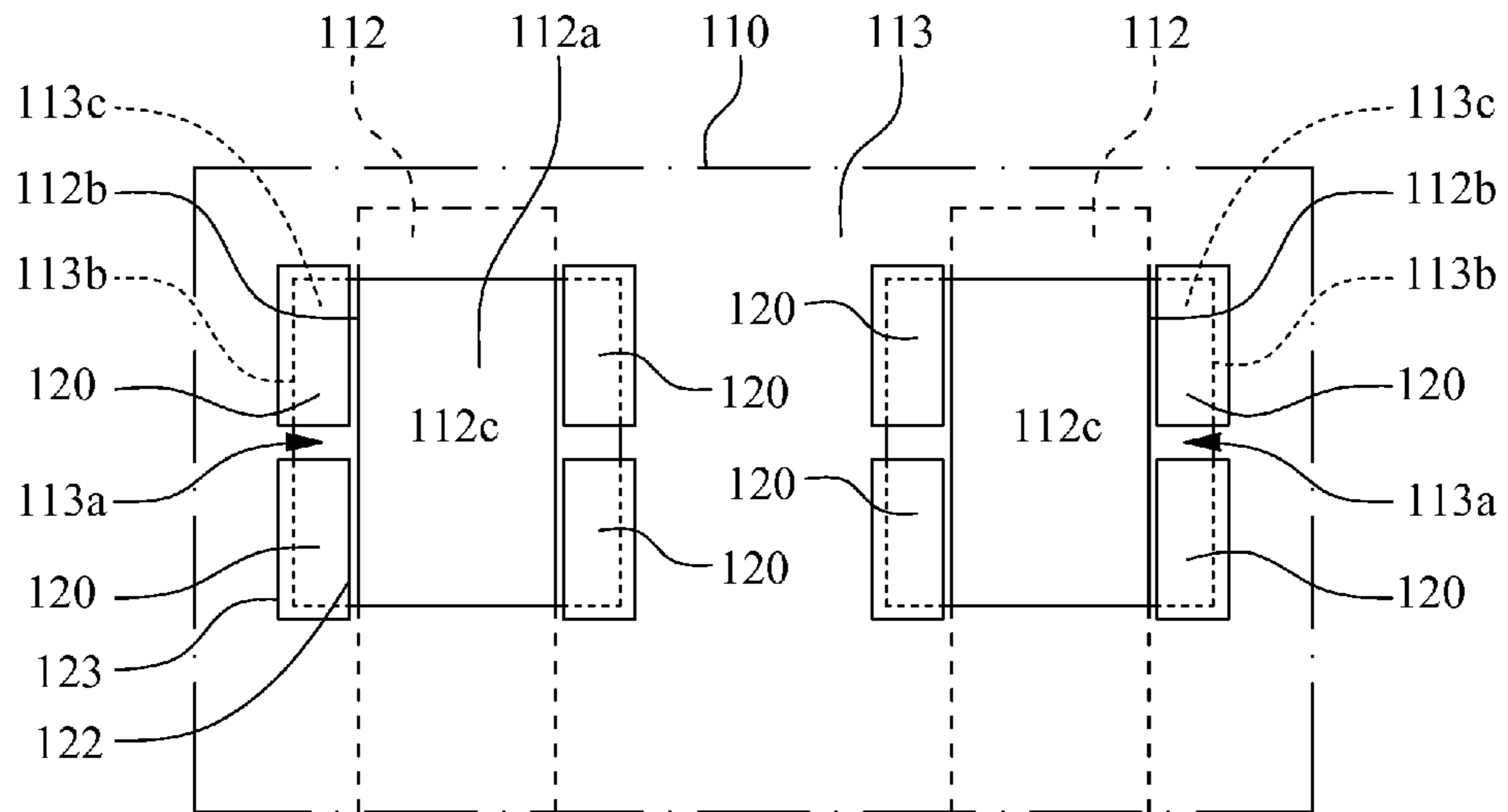

FIG. 3

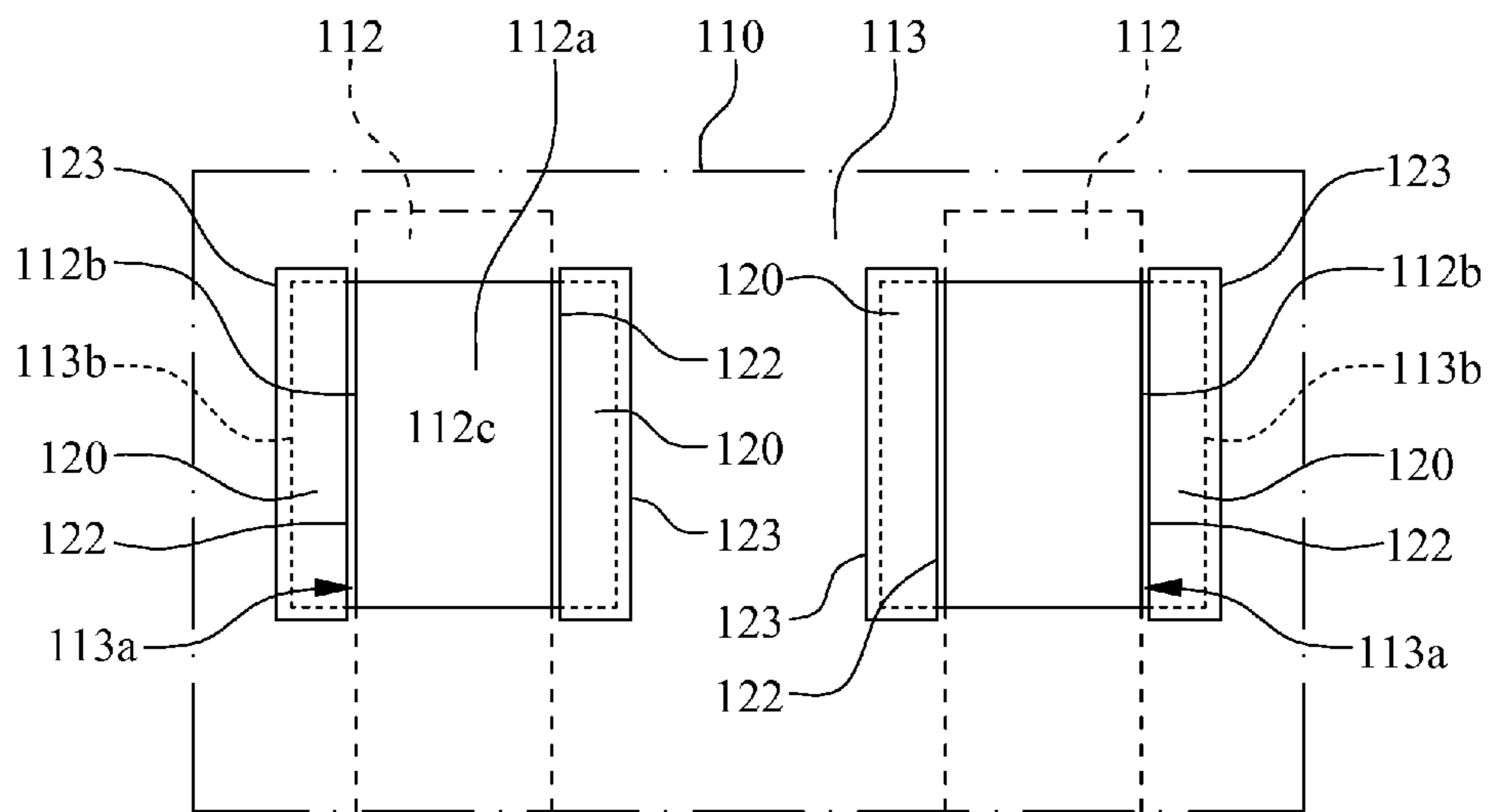

FIG. 4





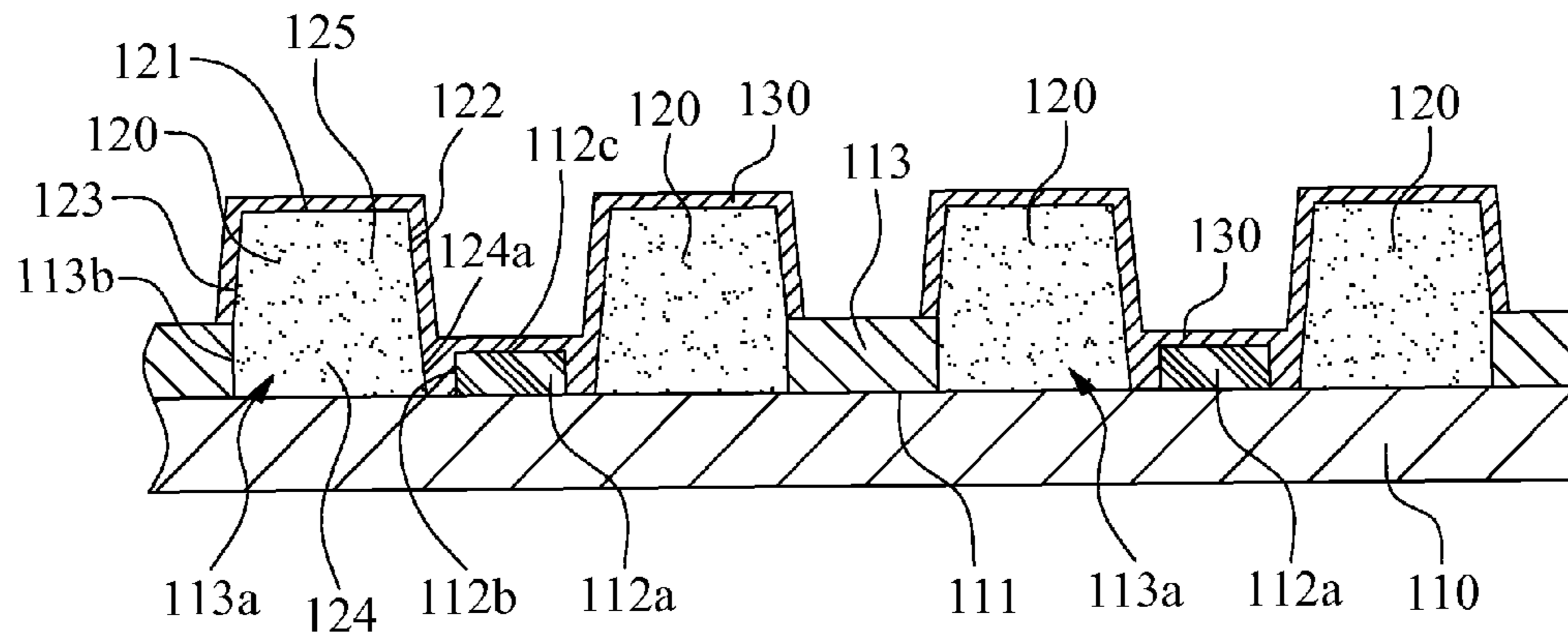

FIG. 7

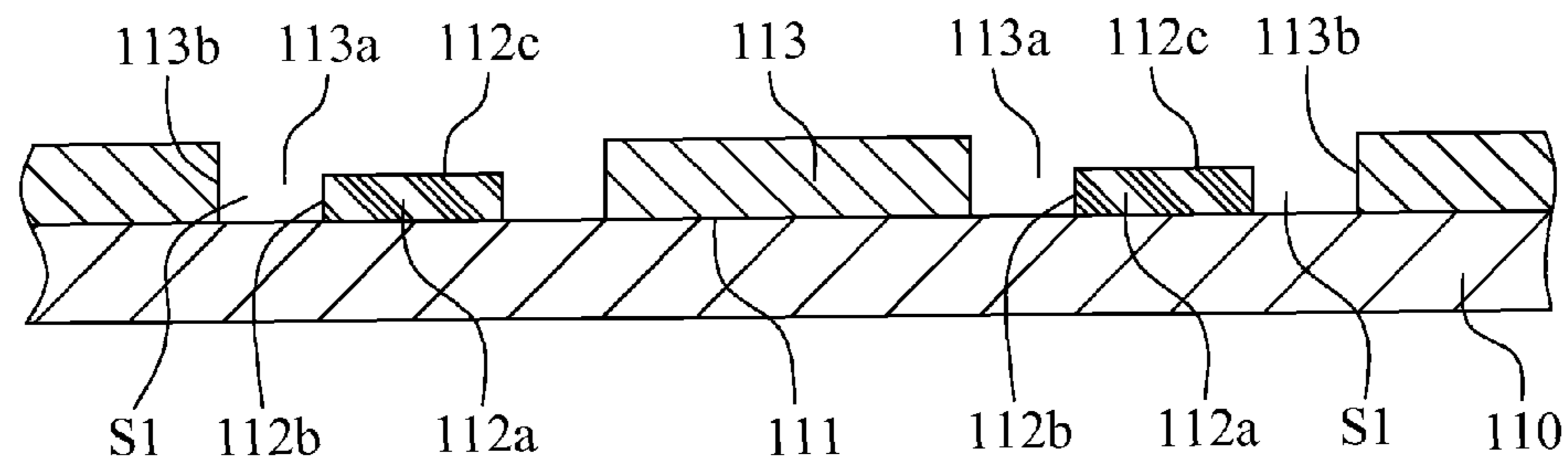

FIG. 8A

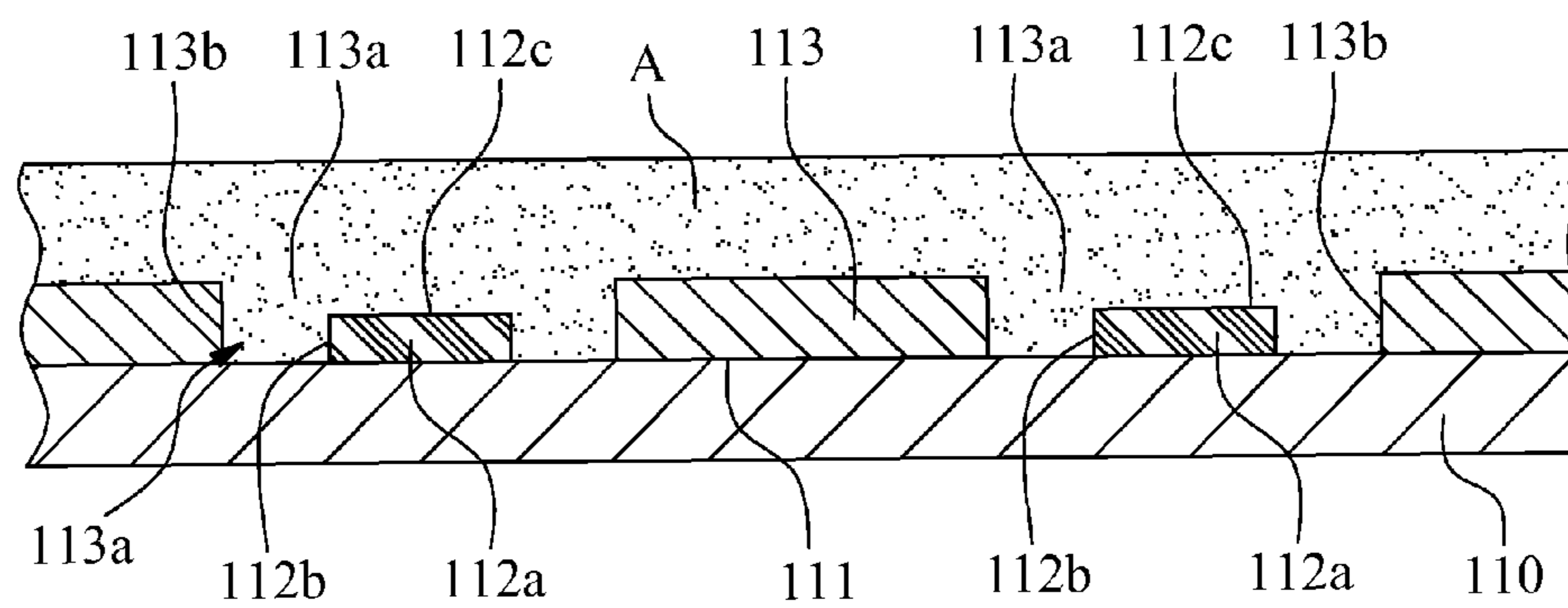

FIG. 8B

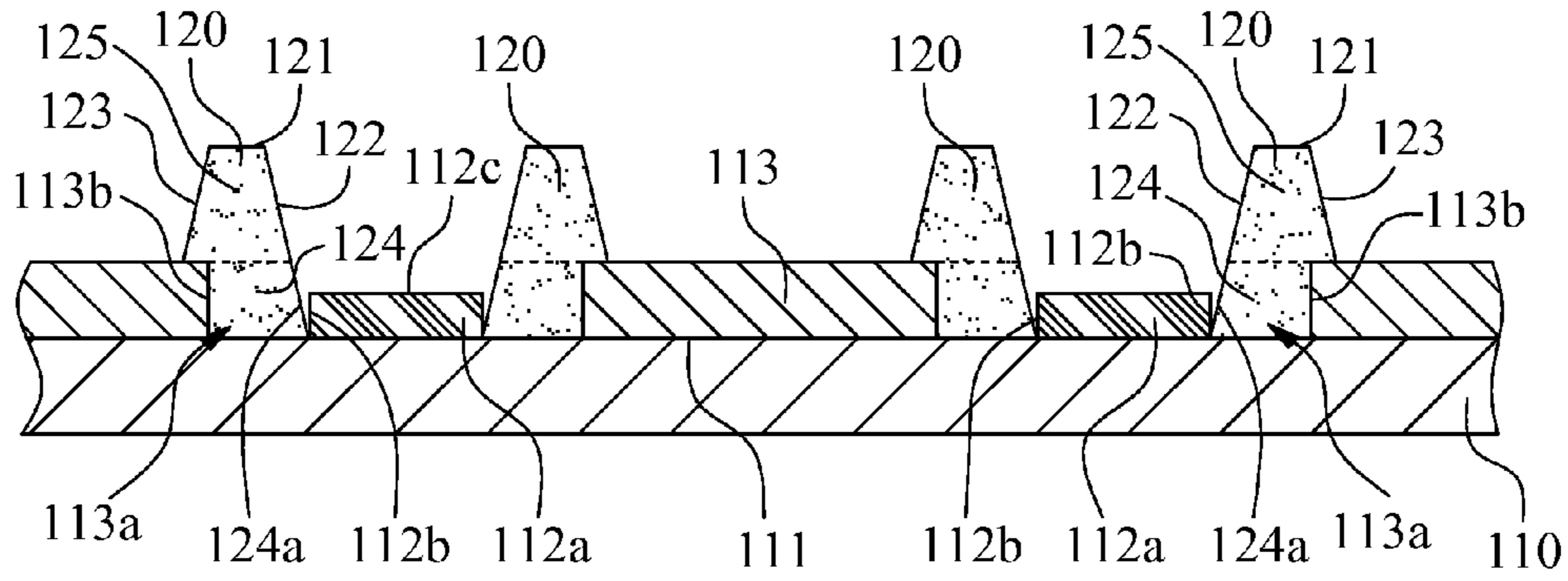

FIG. 8C

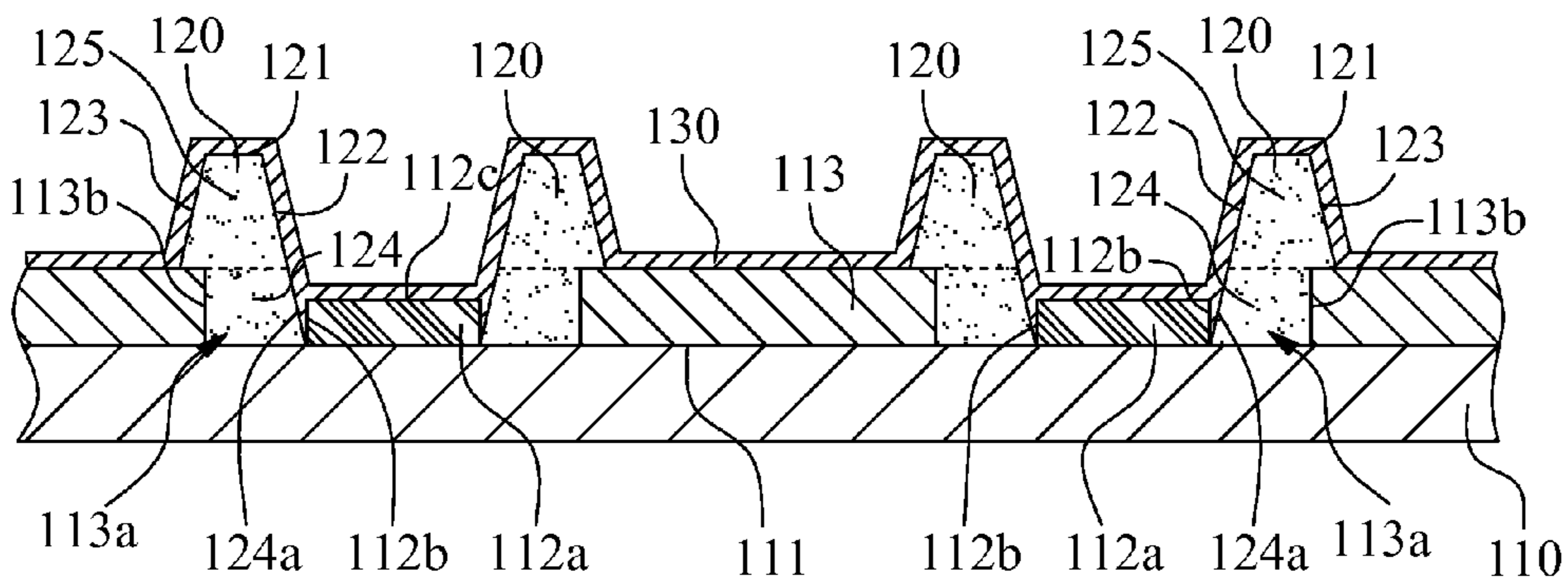

FIG. 8D

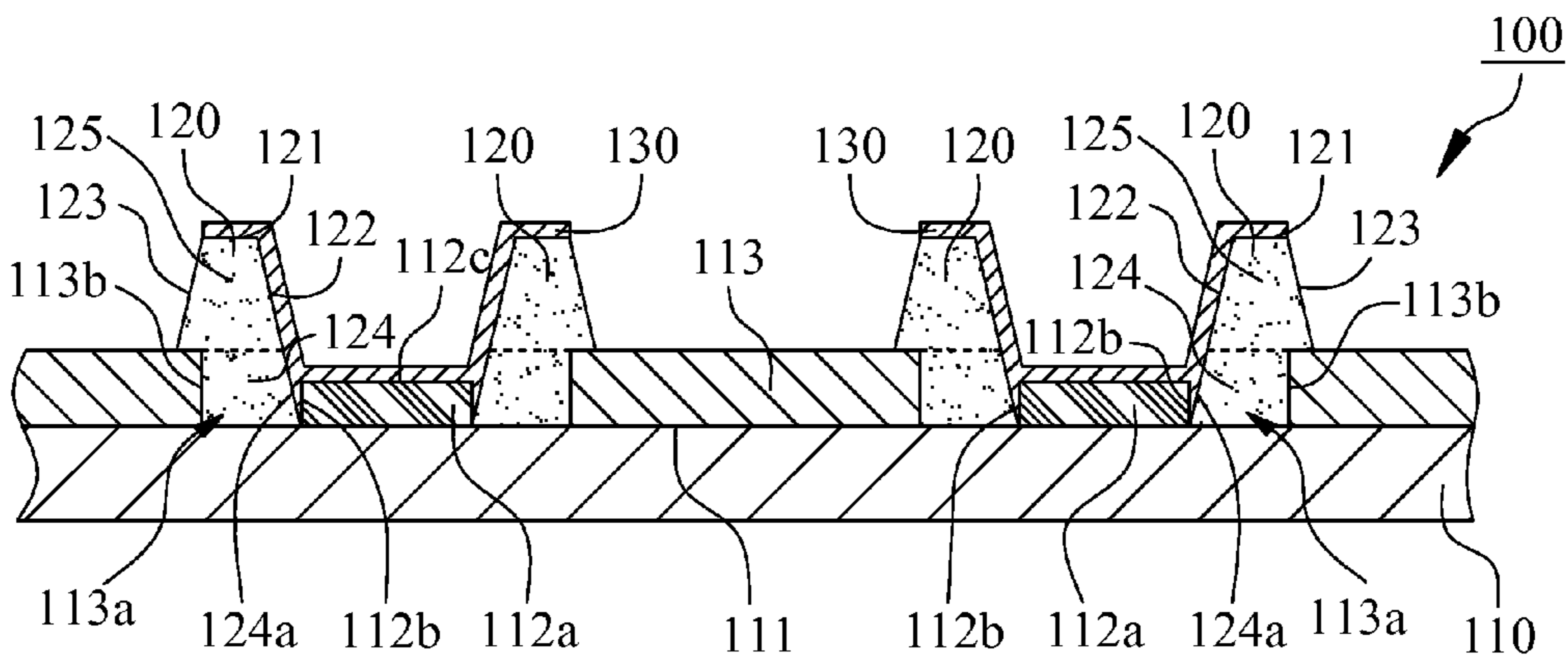

FIG. 8E



1

## SUBSTRATE STRUCTURE WITH COMPLIANT BUMP AND MANUFACTURING METHOD THEREOF

### FIELD OF THE INVENTION

The present invention is generally relating to a substrate structure, more particularly to the substrate structure having compliant bump.

### BACKGROUND OF THE INVENTION

A conventional substrate with bump **10** includes a Si-substrate **11** and a gold bump **12** as shown in FIG. 1. The Si-substrate **11** comprises a surface **11a**, an aluminum pad **11b** formed on the surface **11a**, and a protective layer **11c** covering the aluminum pad **11b**, wherein the protective layer **11c** comprises an opening **11d** to reveal the aluminum pad **11b**, and the gold bump **12** is disposed on the aluminum pad **11b**. Owing to the reason that the bump material of the substrate with bump **10** is gold, mentioned bump structure may lead a higher production cost and bring on a relatively poor economic benefit.

### SUMMARY

The primary object of the present invention is to provide a substrate structure with compliant bump comprising a substrate, a plurality of insulating bumps, and a metallic layer. The substrate comprises a surface, a trace layer formed on the surface, and a protective layer covering the trace layer, wherein the trace layer comprises a plurality of conductive pads, each of the conductive pads comprises an outer lateral wall and an upper surface, the protective layer comprises a plurality of openings, and each of the openings reveals each of the conductive pads. Each of the openings comprises an inner lateral wall, and a first accommodating space is formed between the inner lateral wall and the outer lateral wall. The insulating bumps are formed on the surface and located at the first accommodating space. Each of the insulating bumps comprises a top surface, an inner surface, and an outer surface and defines a first body and a second body. The first body is located on the surface and comprises a first width, and the second body is located on top of the first body and protrudes from the protective layer. A second width is formed between the inner lateral wall and the outer lateral wall, and mentioned second width is not smaller than the first width. The metallic layer is formed on the top surface of each of the insulating bumps, the inner surface, and the upper surface of each of the conductive pads. Accordingly, the substrate structure with compliant bump introduces the insulating bumps to replace conventional gold bumps, and forms the metallic layer on the insulating bumps for achieving the purpose of electric connection. Therefore, mentioned substrate structure with compliant bump may lower production cost.

### DESCRIPTION OF THE DRAWINGS

FIG. 1 is a schematic diagram illustrating a conventional substrate structure with bump.

FIG. 2 is a schematic diagram illustrating a substrate structure with compliant bump in accordance with a first preferred embodiment of the present invention.

FIG. 3 is a top view illustrating the substrate structure with compliant bump in accordance with a first preferred embodiment of the present invention.

2

FIG. 4 is a top view illustrating another substrate structure with compliant bump in accordance with a second preferred embodiment of the present invention.

FIG. 5 is a schematic diagram illustrating another substrate structure with compliant bump in accordance with a third preferred embodiment of the present invention.

FIG. 6 is a schematic diagram illustrating another substrate structure with compliant bump in accordance with a fourth preferred embodiment of the present invention.

FIG. 7 is a schematic diagram illustrating another substrate structure with compliant bump in accordance with a fifth preferred embodiment of the present invention.

FIGS. 8A to 8E are sectional diagrams illustrating a manufacturing method of the substrate structure with compliant bump in accordance with a first preferred embodiment of the present invention.

### DETAILED DESCRIPTION OF THE INVENTION

Please refers to FIG. 2, a substrate structure with compliant bump **100** in accordance with a first preferred embodiment of the present invention comprises a substrate **110**, a plurality of insulating bumps **120**, and a metallic layer **130**. With reference to FIGS. 2 and 3, the substrate **110** comprises a surface **111**, a trace layer **112** formed on the surface **111**, and a protective layer **113** covering the trace layer **112**, wherein the trace layer **112** comprises a plurality of conductive pads **112a**, and each of the conductive pads **112a** comprises an outer lateral wall **112b** and an upper surface **112c**. The protective layer **113** comprises a plurality of openings **113a**, and each of the openings **113a** reveals each of the conductive pads **112a** and comprises an inner lateral wall **113b**. A first accommodating space **S1** is formed between the inner lateral wall **113b** and the outer lateral wall **112b**, and the insulating bumps **120** are formed on the surface **111** and located at the first accommodating space **S1**. In this embodiment, each of the openings **113a** comprises a plurality of corners **113c**, and each of the insulating bumps **120** is located at one of the corners **113c**. Or, with reference to FIG. 4, in the second preferred embodiment, adjacent insulating bumps **120** are interconnected therefore forming larger-sized insulating bump **120**.

Referring to FIGS. 2 and 3 again, in this embodiment, the material of the substrate **110** can be chosen from one of glass substrate, silicon substrate, ceramic substrate, or printed circuit board. Each of the insulating bumps **120** comprises a top surface **121**, an inner surface **122**, and an outer surface **123** and defines a first body **124** and a second body **125**, wherein the first body **124** is located on the surface **111** and comprises a first width **D1**, the second body **125** is located on top of the first body **124** and protrudes from the protective layer **113**. In this embodiment, the second body **125** is extendedly formed at the protective layer **113**. Besides, a second width **D2** is formed between the inner lateral wall **113b** and the outer lateral wall **112b**, and the second width **D2** is not smaller than the first width **D1**. In this embodiment, the second width **D2** is equal to the first width **D1**. The metallic layer **130** is formed on the top surface **121**, the inner surface **122** of each of the insulating bumps **120**, and the upper surface **112c** of each of the conductive pads **112a**. Or, referring to FIG. 5, in the third preferred embodiment, the metallic layer **130** is formed on the outer surface **123** of the insulating bump **120**.

With reference to FIG. 6, in the fourth preferred embodiment, the second width **D2** is larger than the first width **D1**. The first body **124** comprises a first internal surface **124a**, and a second accommodating space **S2** is formed between the first internal surface **124a** and the outer lateral wall **112b** of the conductive pad **112a**. The metallic layer **130** is formed at the



3

outer lateral wall **112b** of the conductive pad **112a** and the second accommodating space **S2**. In this embodiment, the metallic layer **130** further forms on the surface **111** of the substrate **110**, or, with reference to FIG. 7, the metallic layer **130** further forms on the outer surface **123** of the insulating bump **120**. Accordingly, the substrate structure with compliant bump **100** introduces the insulating bumps **120** to replace conventional gold bumps and forms the metallic layer **130** on the insulating bumps **120** for achieving the purpose of electric connection. Therefore, mentioned substrate structure with compliant bump **100** may lower production cost.

Referring to FIGS. **8A** to **8E**, a manufacturing method of the substrate structure with compliant bump in accordance with the first preferred embodiment comprises the following steps of: first, with reference to FIGS. **3** and **8A**, providing a substrate **110** having a surface **111**, a trace layer **112** formed on the surface **111**, and a protective layer **113** covering the trace layer **112**, wherein the trace layer **112** comprises a plurality of conductive pads **112a**, each of the conductive pads **112a** comprises an outer lateral wall **112b** and an upper surface **112c**, the protective layer **113** comprises a plurality of openings **113a**, each of the openings **113a** reveals each of the conductive pads **112a** and comprises an inner lateral wall **113b**, a first accommodating space **S1** is formed between the inner lateral wall **113b** and the outer lateral wall **112b**, and the material of the substrate **110** can be chosen from one of glass substrate, silicon substrate, ceramic substrate, and printed circuit board; next, with reference to FIG. **8B**, forming a photoresist layer **A** on the surface **111** of the substrate **110** and covering the trace layer **112** and the protective layer **113** with the photoresist layer **A**; thereafter, referring to FIG. **8C**, patterning the photoresist layer **A** to form a plurality of insulating bumps **120**, mentioned insulating bumps **120** are formed on the surface **111** and located at the first accommodating space **S1**, each of the insulating bumps **120** comprises a top surface **121**, an inner surface **122**, and an outer surface **123** and defines a first body **124** and a second body **125**, wherein the first body **124** is located on the surface **111** and comprises a first width **D1**, the second body **125** is located on top of the first body **124** and protrudes from the protective layer **113**, a second width **D2** is formed between the inner lateral wall **113b** and the outer lateral wall **112b**, mentioned second width **D2** is not smaller than the first width **D1**, in this embodiment, the second width **D2** is equal to the first width **D1**, afterwards, with reference to FIG. **8D**, forming a metallic layer **130** on the top surface **121**, the inner surface **122**, the outer surface **123** of each of the insulating bumps **120**, the protective layer **113** and the upper surface **112c** of each of the conductive pads **112a**, eventually, referring to FIG. **8E**, removing the metallic layer

4

**130** located at the protective layer **113** and the outer surface **123** of the insulating bump **120** therefore forming a substrate structure with compliant bump **100**.

While this invention has been particularly illustrated and described in detail with respect to the preferred embodiments thereof, it will be clearly understood by those skilled in the art that it is not limited to the specific features and describes and various modifications and changes in form and details may be made without departing from the spirit and scope of this invention.

What is claimed is:

**1.** A manufacturing method of a substrate structure with compliant bump comprises the steps of:

providing a substrate having a surface, a trace layer formed on the surface and a protective layer covering the trace layer, wherein the trace layer comprises a plurality of conductive pads, each of the conductive pads comprises an outer lateral wall and an upper surface, the protective layer comprises a plurality of openings, each of the openings reveals each of the conductive pads and comprises an inner lateral wall, wherein a first accommodating space is formed between the inner lateral wall and the outer lateral wall;

forming a photoresist layer on the surface of the substrate and covering the trace layer and the protective layer with the photoresist layer;

patterning the photoresist layer to form a plurality of insulating bumps, mentioned insulating bumps are formed on the surface and located at the first accommodating space, each of the insulating bumps comprises a top surface, an inner surface and an outer surface and defines a first body and a second body, wherein the first body is located on the surface and comprises a first width, the second body is located on top of the first body and protrudes from the protective layer, a second width is formed between the inner lateral wall and the outer lateral wall, and mentioned second width is not smaller than the first width;

forming a metallic layer on the top surface, the inner surface, the outer surface of the insulating bump, the protective layer, and the upper surface of the conductive pad; and

removing the metallic layer located at the protective layer.

**2.** The manufacturing method of a substrate structure with compliant bump in accordance with claim **1** further comprises the step of removing the metallic layer located at the outer surface of the insulating bump.

\* \* \* \* \*