

US008469864B2

(12) **United States Patent**
Hetrick

(10) **Patent No.:** **US 8,469,864 B2**
(45) **Date of Patent:** **Jun. 25, 2013**

(54) **EXERCISE DEVICE HAVING INELASTIC STRAPS AND INTERCHANGEABLE PARTS**

(75) Inventor: **Randal Hetrick**, San Francisco, CA (US)
(73) Assignee: **Fitness Anywhere, LLC**, San Francisco, CA (US)
(*) Notice: Subject to any disclaimer, the term of this patent is extended or adjusted under 35 U.S.C. 154(b) by 0 days.

(21) Appl. No.: **13/251,440**

(22) Filed: **Oct. 3, 2011**

(65) **Prior Publication Data**
US 2012/0077646 A1 Mar. 29, 2012

Related U.S. Application Data
(63) Continuation of application No. 11/948,875, filed on Nov. 30, 2007, now Pat. No. 8,043,197.
(60) Provisional application No. 60/973,129, filed on Sep. 17, 2007.

(51) **Int. Cl.**
A63B 21/002 (2006.01)
A63B 21/068 (2006.01)
(52) **U.S. Cl.**
USPC **482/91**; 482/96; 482/904
(58) **Field of Classification Search**
USPC 482/114, 120–133, 139, 904, 38–40, 482/47–49, 23–24, 28, 91–92, 95–96, 140–141, 482/148, 907–908
See application file for complete search history.

(56) **References Cited**

U.S. PATENT DOCUMENTS			
3,519,269	A *	7/1970	Howlett et al. 482/120
3,739,772	A *	6/1973	Ennis 602/4
4,059,265	A *	11/1977	Wieder et al. 482/125
4,060,240	A *	11/1977	Dunston 482/131
4,073,490	A *	2/1978	Feather 482/129
4,220,328	A *	9/1980	Crush, Jr. 482/92
4,337,938	A *	7/1982	Rodriguez 482/74
4,463,948	A *	8/1984	Mohr 482/129
4,466,612	A *	8/1984	Marczewski 482/120
4,477,073	A *	10/1984	Koch et al. 482/91
4,544,155	A *	10/1985	Wallenbrock et al. 482/129
4,948,117	A *	8/1990	Burke 482/55
5,100,129	A *	3/1992	Porter et al. 482/129
5,176,602	A *	1/1993	Roberts 482/131
5,514,059	A *	5/1996	Romney 482/124
5,653,668	A *	8/1997	Wilkinson 482/124
5,766,118	A *	6/1998	Conner 482/129
5,852,988	A *	12/1998	Gish 119/795
5,871,424	A *	2/1999	Conner 482/129
5,910,073	A *	6/1999	Conner 482/129
5,967,947	A *	10/1999	Glover 482/91
6,059,698	A *	5/2000	Mazor 482/79
6,102,837	A *	8/2000	Hubbard 482/120
6,110,075	A *	8/2000	Woodruff 482/47
6,113,564	A *	9/2000	McGuire 602/32
6,245,001	B1 *	6/2001	Siaperas 482/142
6,273,029	B1 *	8/2001	Gish 119/792
6,662,753	B1 *	12/2003	Sporn 119/797

(Continued)
Primary Examiner — Oren Ginsberg
(74) *Attorney, Agent, or Firm* — Vedder Price PC

(57) **ABSTRACT**
An exercise device having an anchor with multiple components is described. In one embodiment, the anchor includes one or more interlocking components, such as rigid or flexible loops. Rigid loops such as gated rings may advantageously be used to connect the different components. Embodiments permit for replacing, interchanging, or adding components to an exercise device anchor.

16 Claims, 31 Drawing Sheets

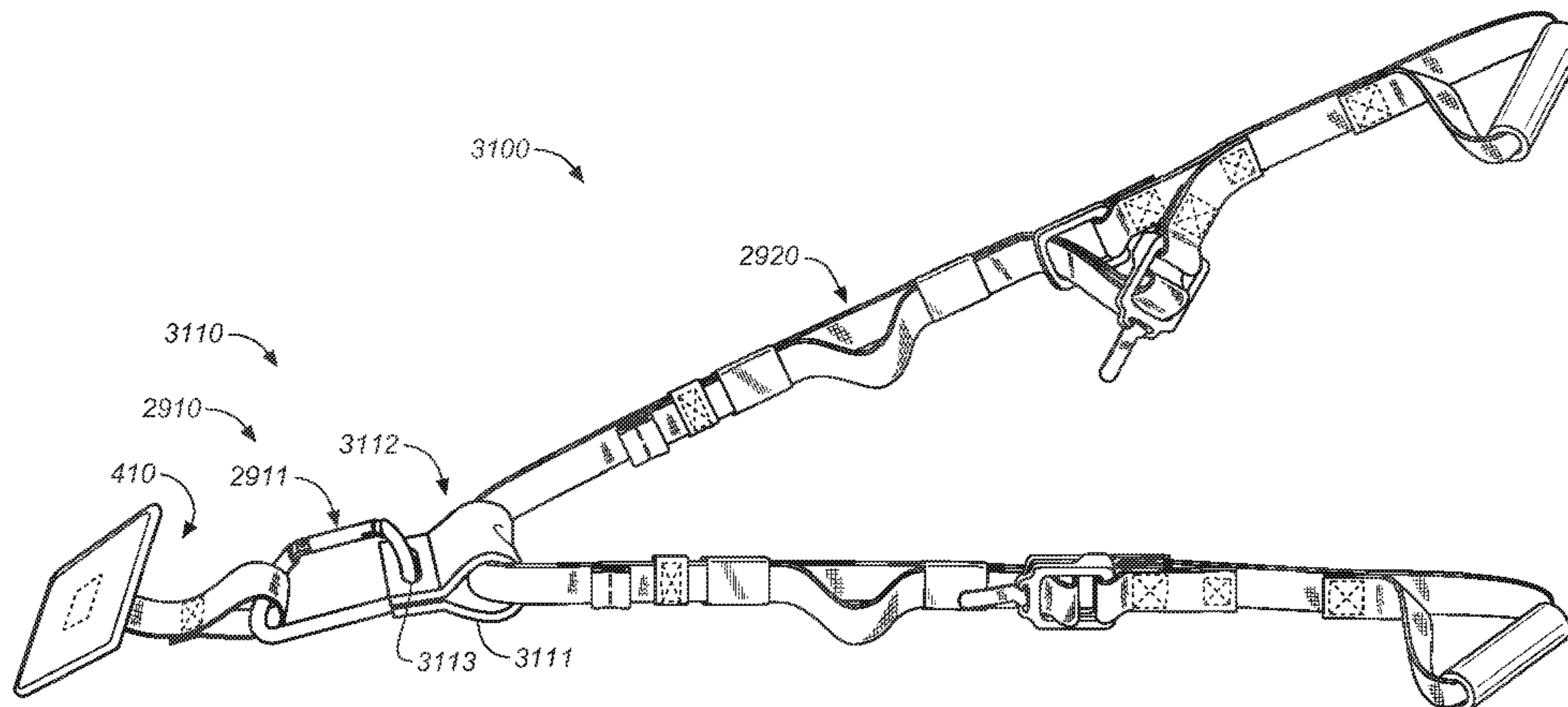

US 8,469,864 B2

Page 2

U.S. PATENT DOCUMENTS

6,726,606	B2 *	4/2004	Jacobsen	482/121	2004/0116259	A1 *	6/2004	Rosiles	482/121
6,835,169	B2 *	12/2004	Tamaribuchi	482/139	2004/0204301	A1 *	10/2004	Hetrick	482/91
7,137,935	B2 *	11/2006	Clarke et al.	482/123	2005/0085350	A1 *	4/2005	Shen	482/91
7,291,099	B1 *	11/2007	Marczewski	482/114	2005/0113223	A1 *	5/2005	Dovner et al.	482/121
7,293,531	B2 *	11/2007	Young, III	119/798	2005/0170937	A1 *	8/2005	van Straaten	482/124
7,326,157	B2 *	2/2008	Wu	482/126	2005/0233875	A1 *	10/2005	Clarke et al.	482/123
7,343,647	B1 *	3/2008	Kinsky et al.	24/3.13	2006/0081197	A1 *	4/2006	Kuykendall	119/792
2003/0045408	A1 *	3/2003	Seles	482/121	2006/0084556	A1 *	4/2006	Payne	482/121
2003/0078142	A1 *	4/2003	Jacobsen	482/126	2006/0183609	A1 *	8/2006	Flynn	482/124
2003/0216220	A1 *	11/2003	Rota	482/27	2006/0264302	A1 *	11/2006	Sjodin	482/91
2004/0087420	A1 *	5/2004	Montesquieux	482/129					

* cited by examiner

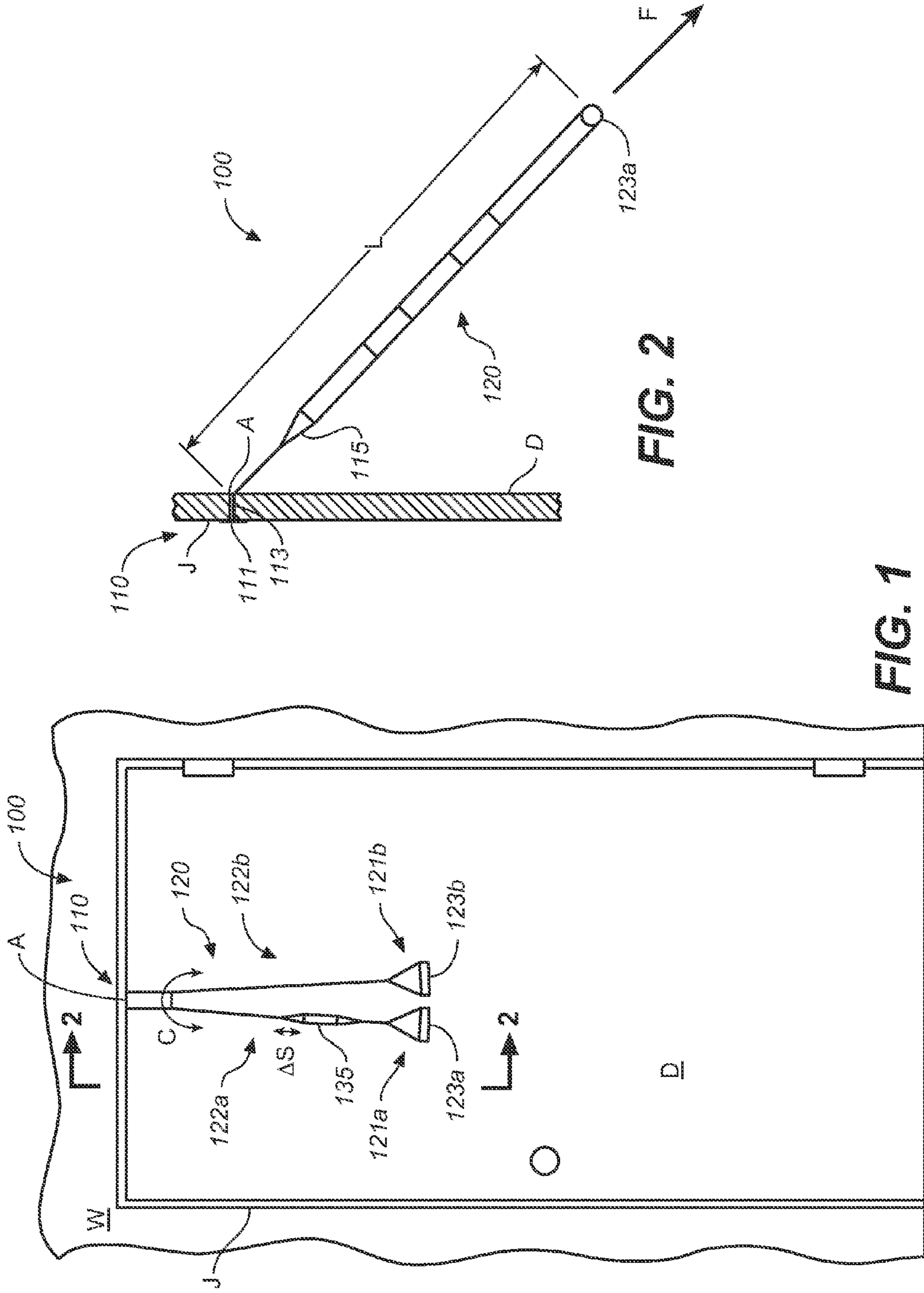

FIG. 1

FIG. 2

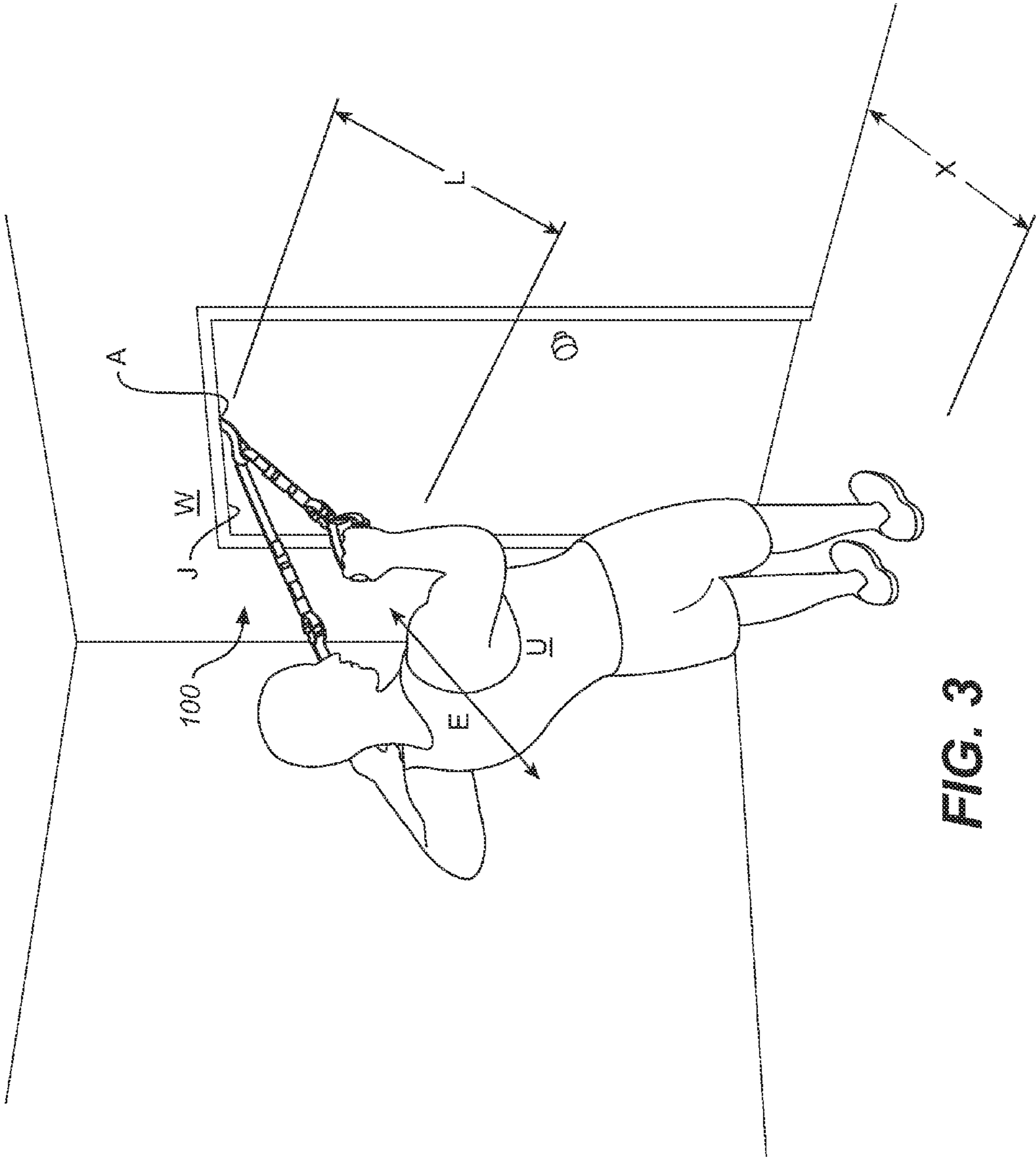

FIG. 3

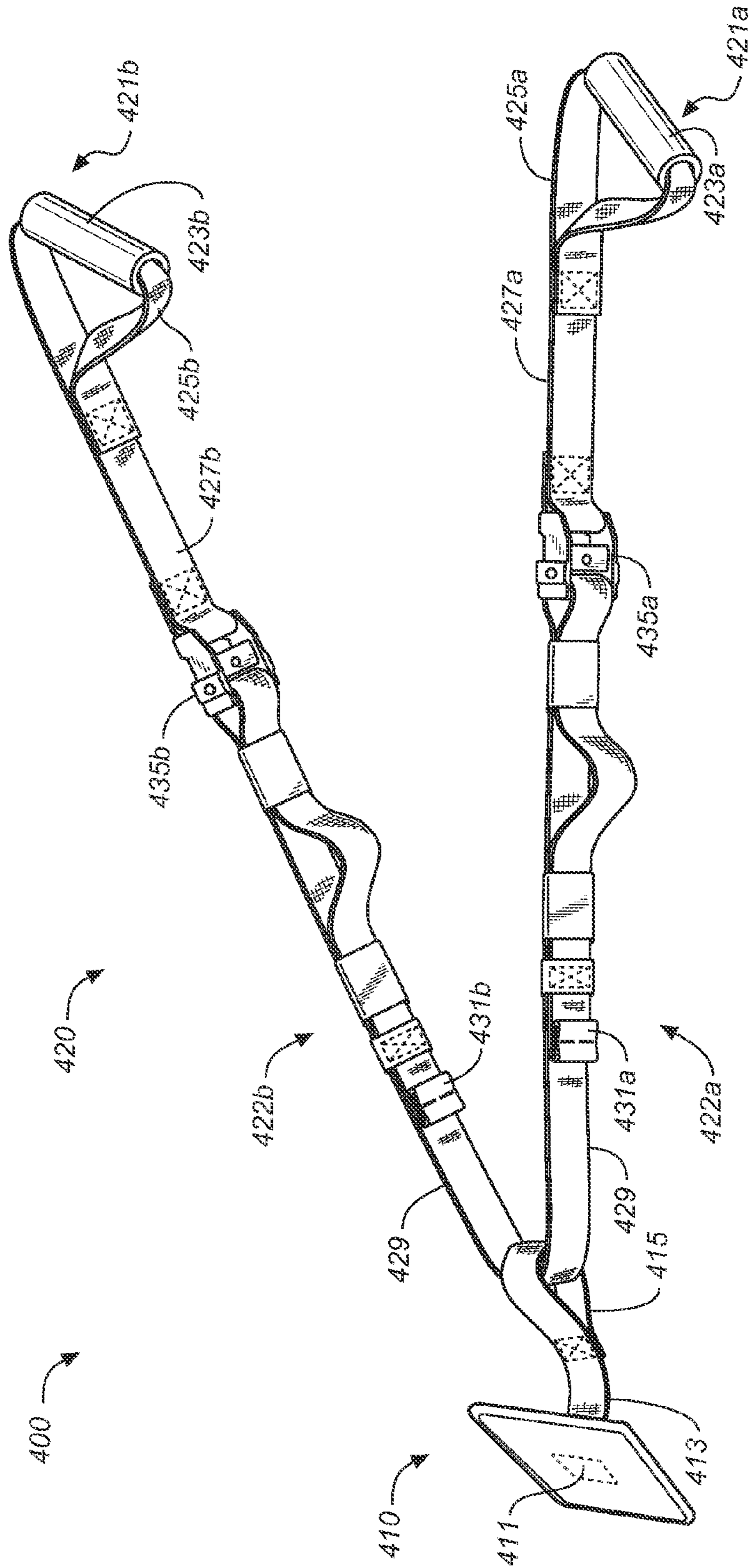

FIG. 4

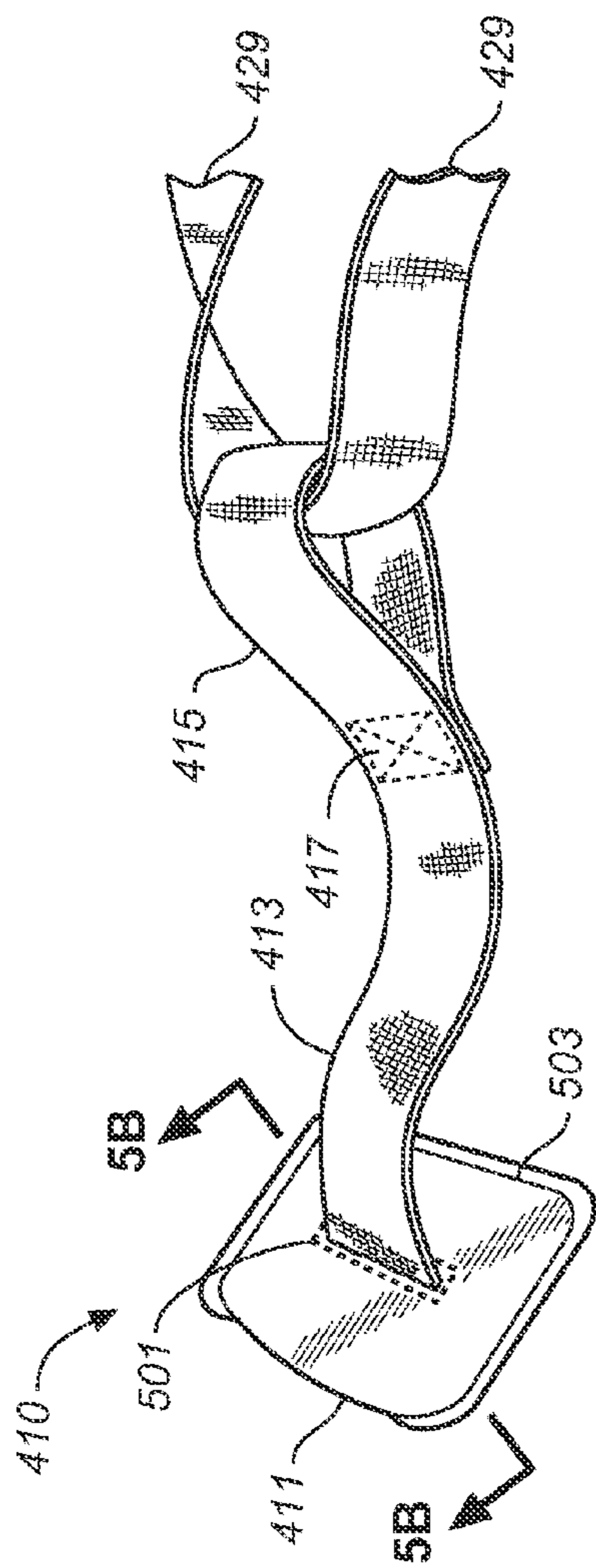

FIG. 5A

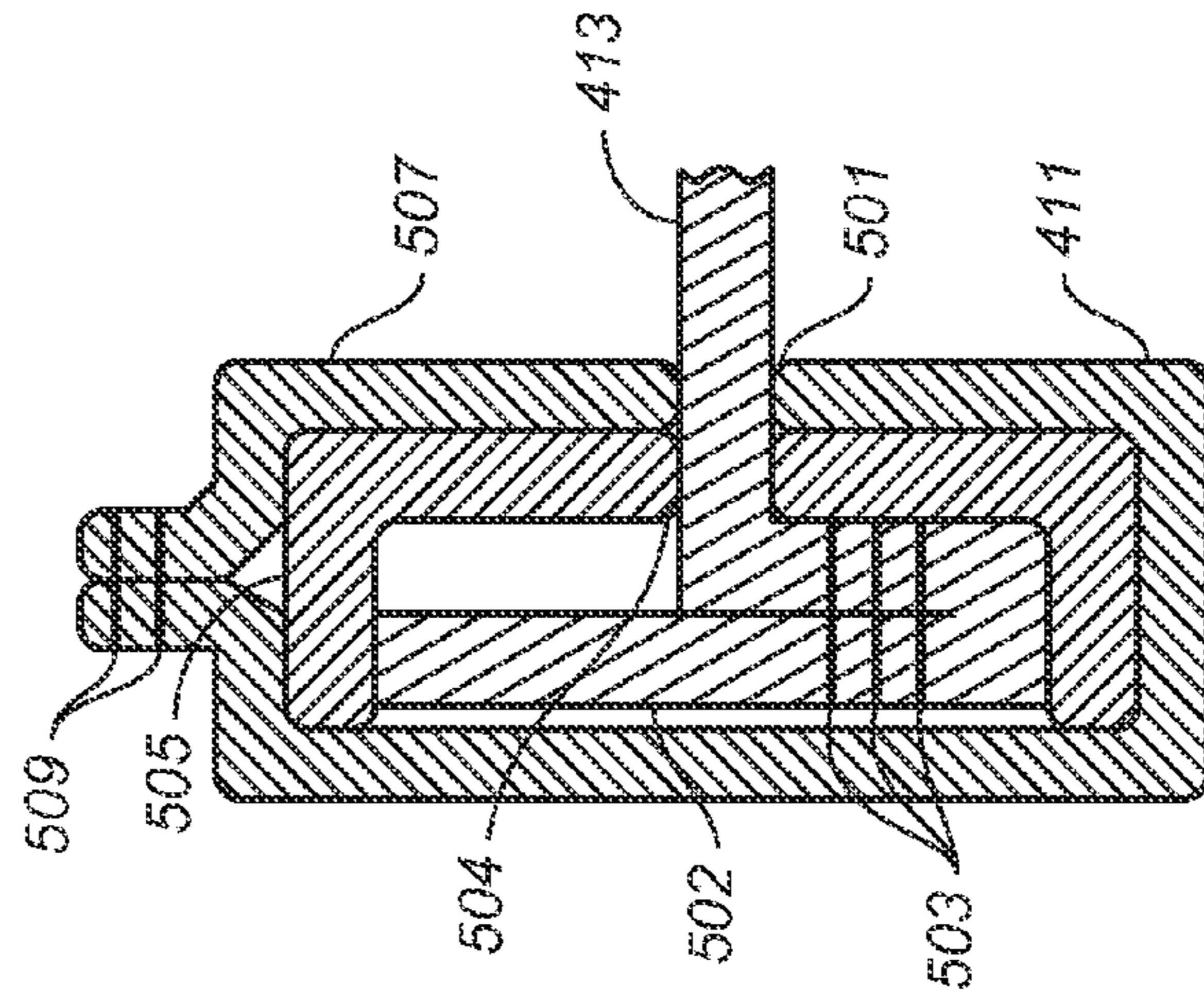

FIG. 5B

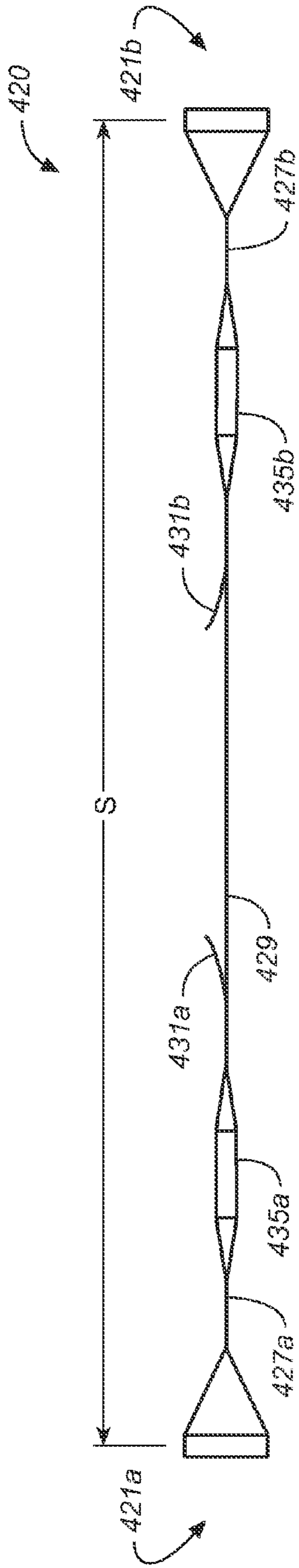

FIG. 6

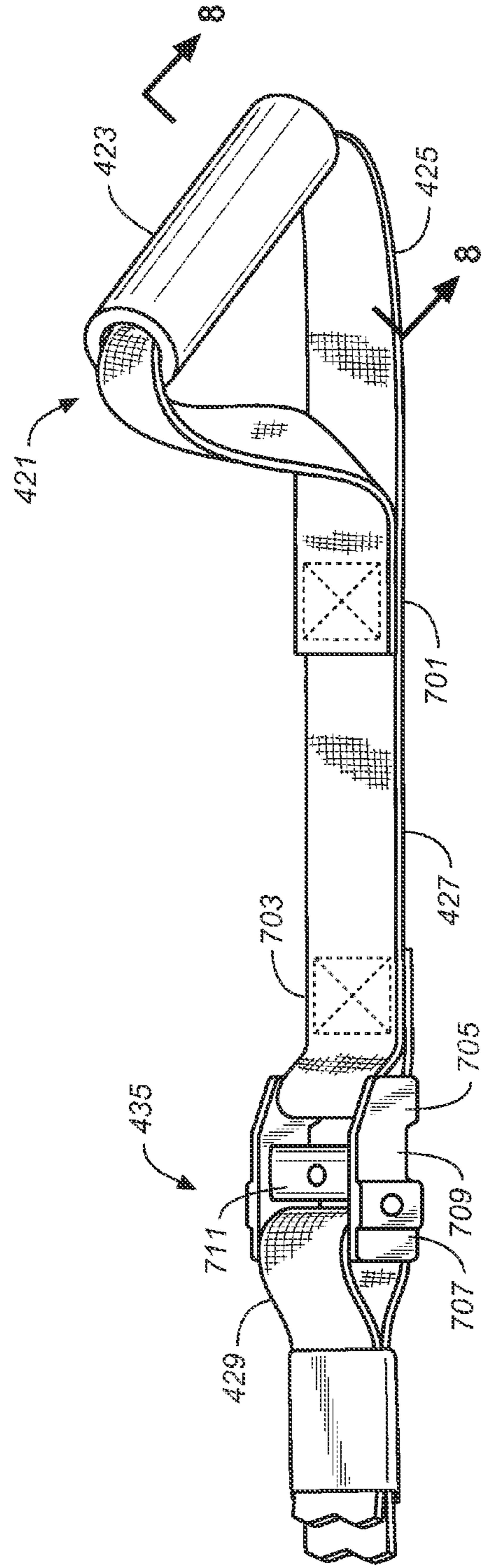

FIG. 7

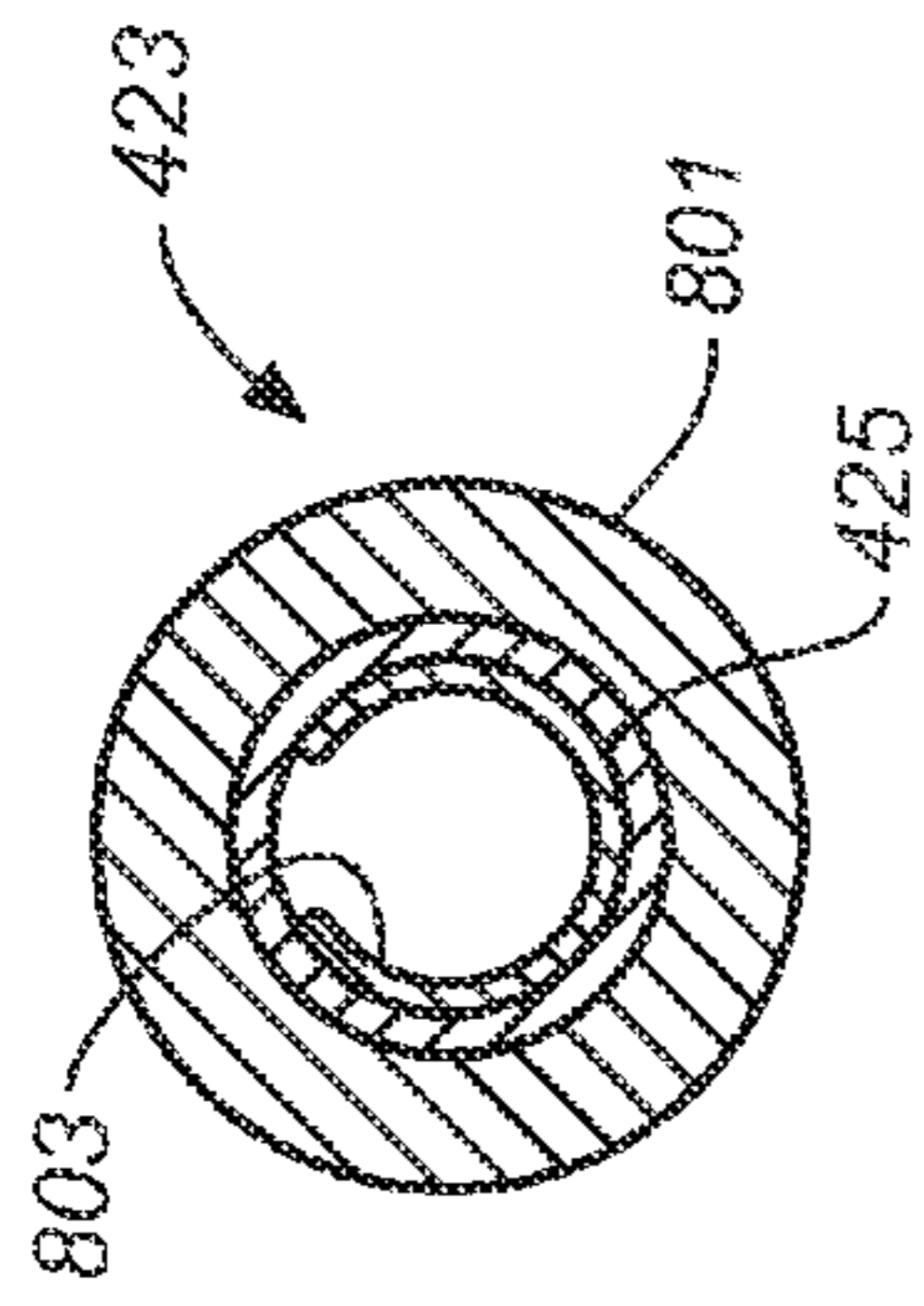

FIG. 8

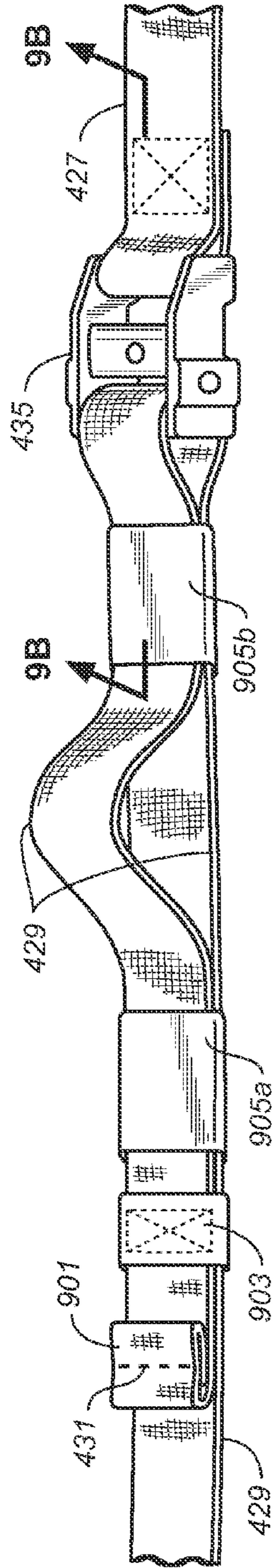

FIG. 9A

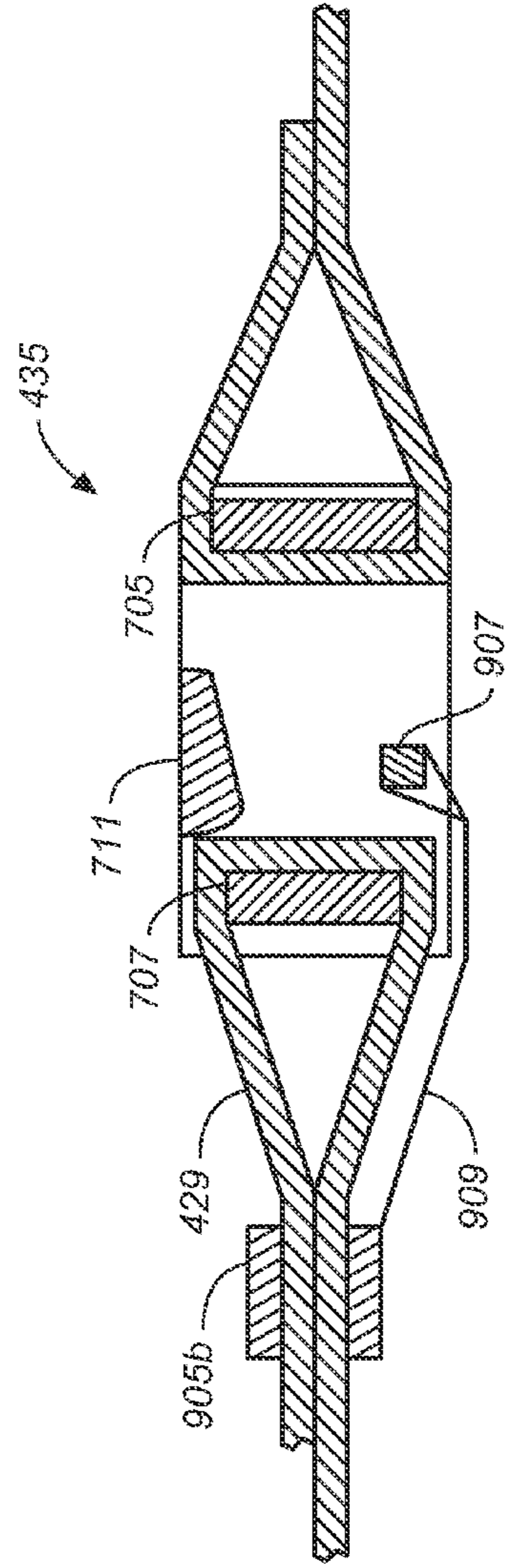

FIG. 9B

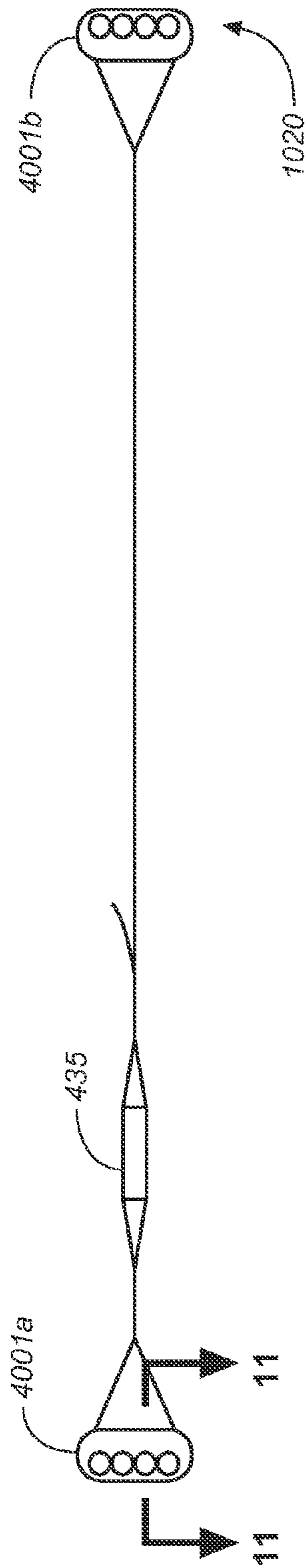

FIG. 10

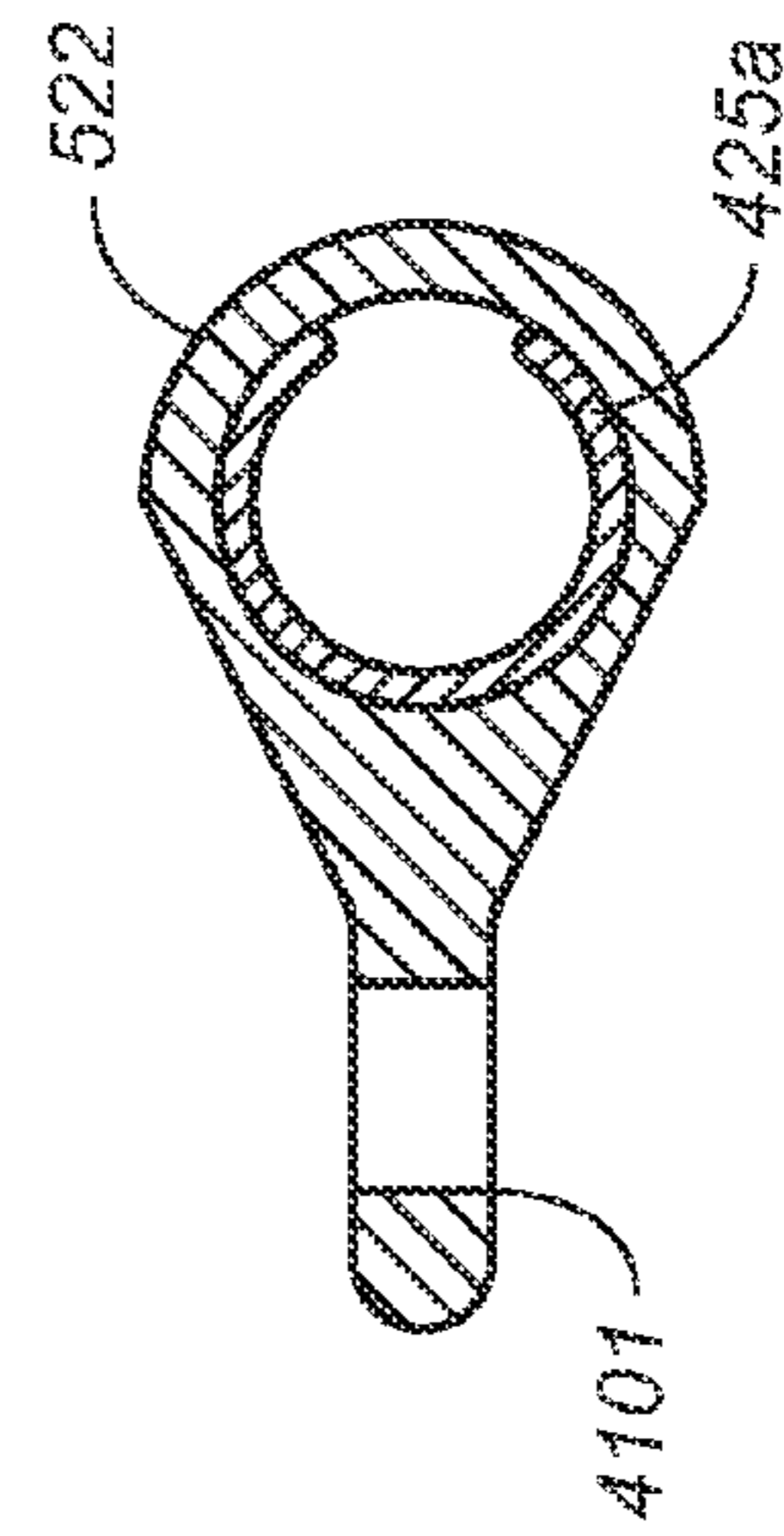

FIG. 11

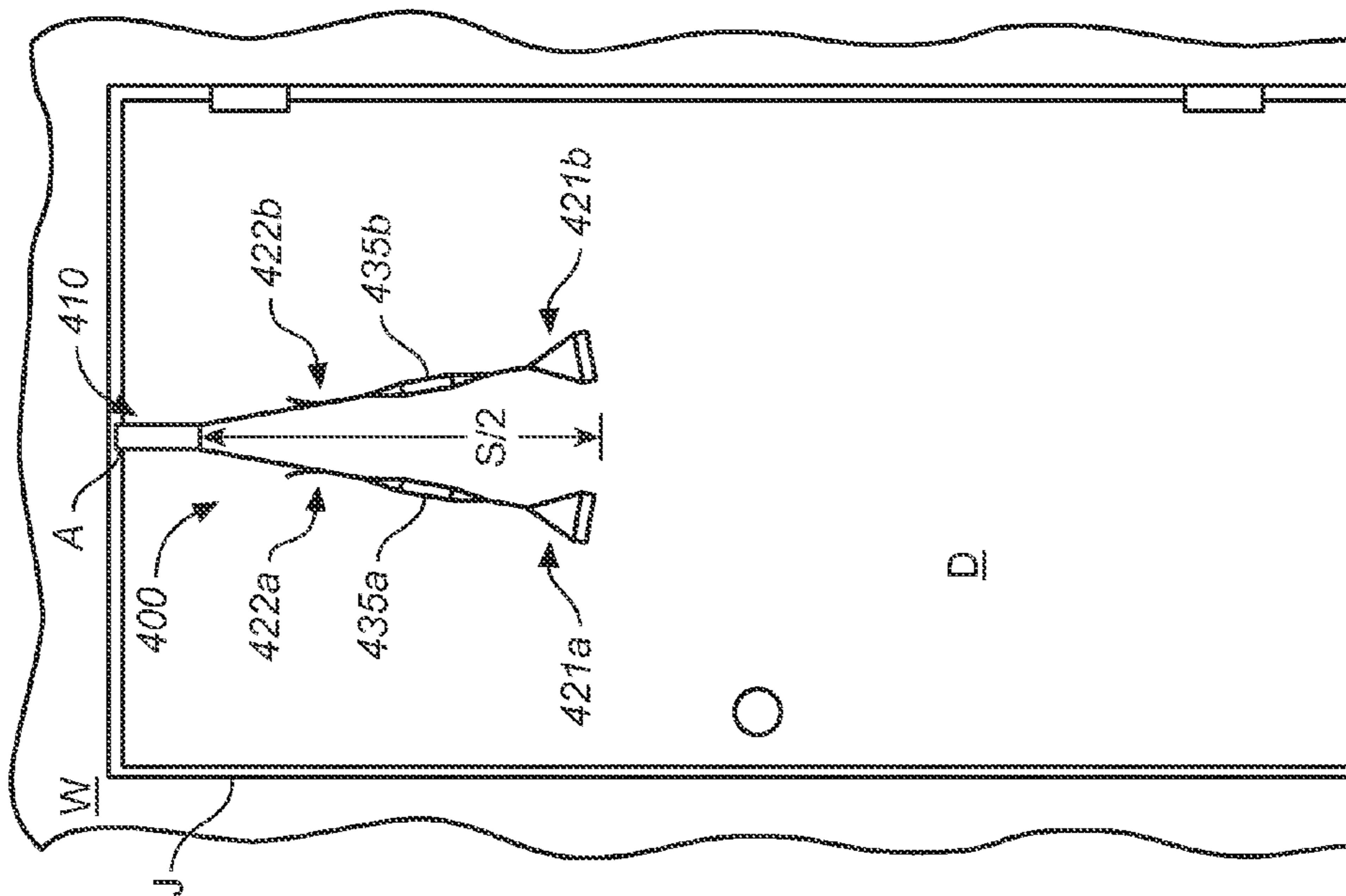

FIG. 12A

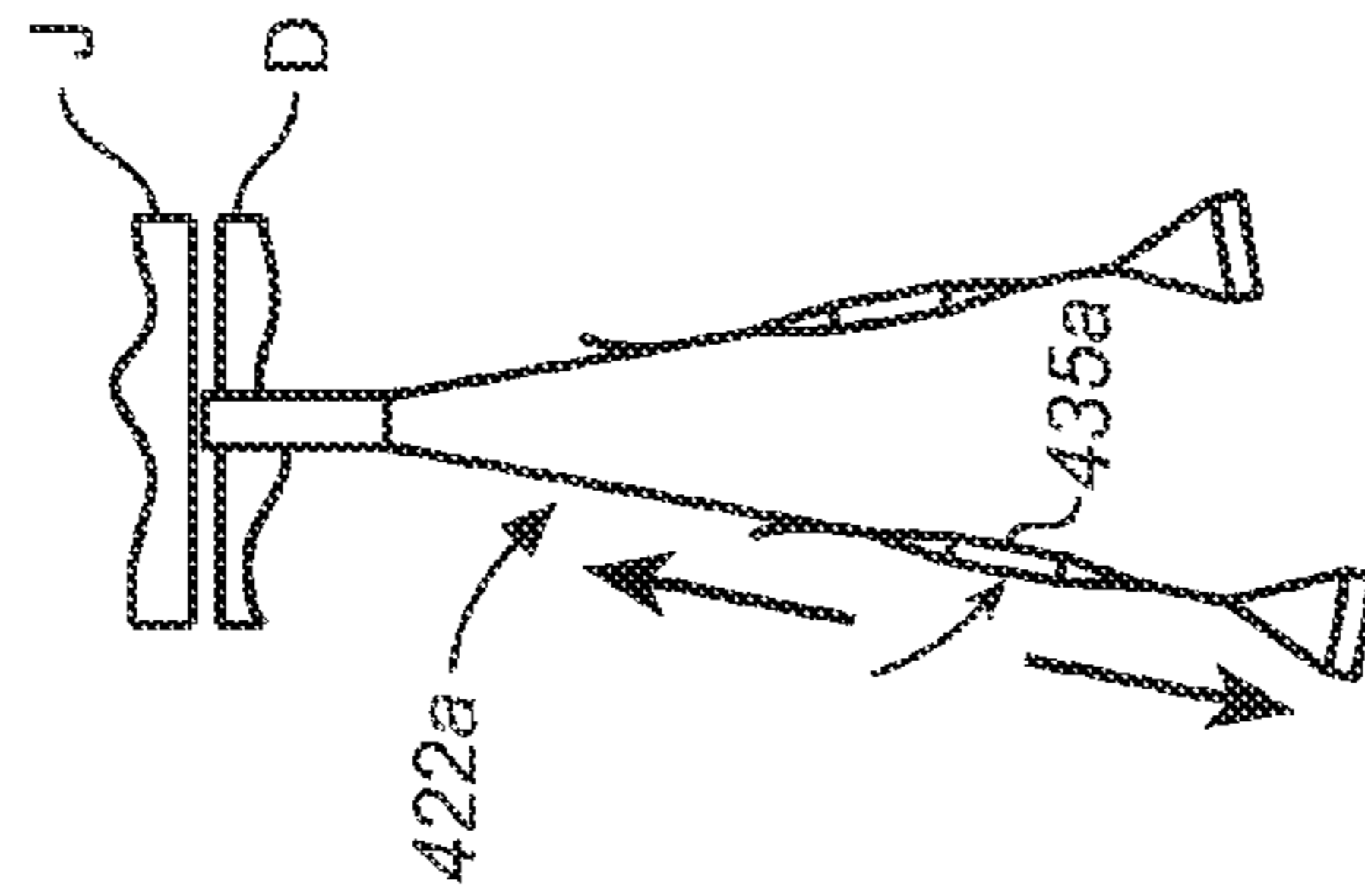

FIG. 12B

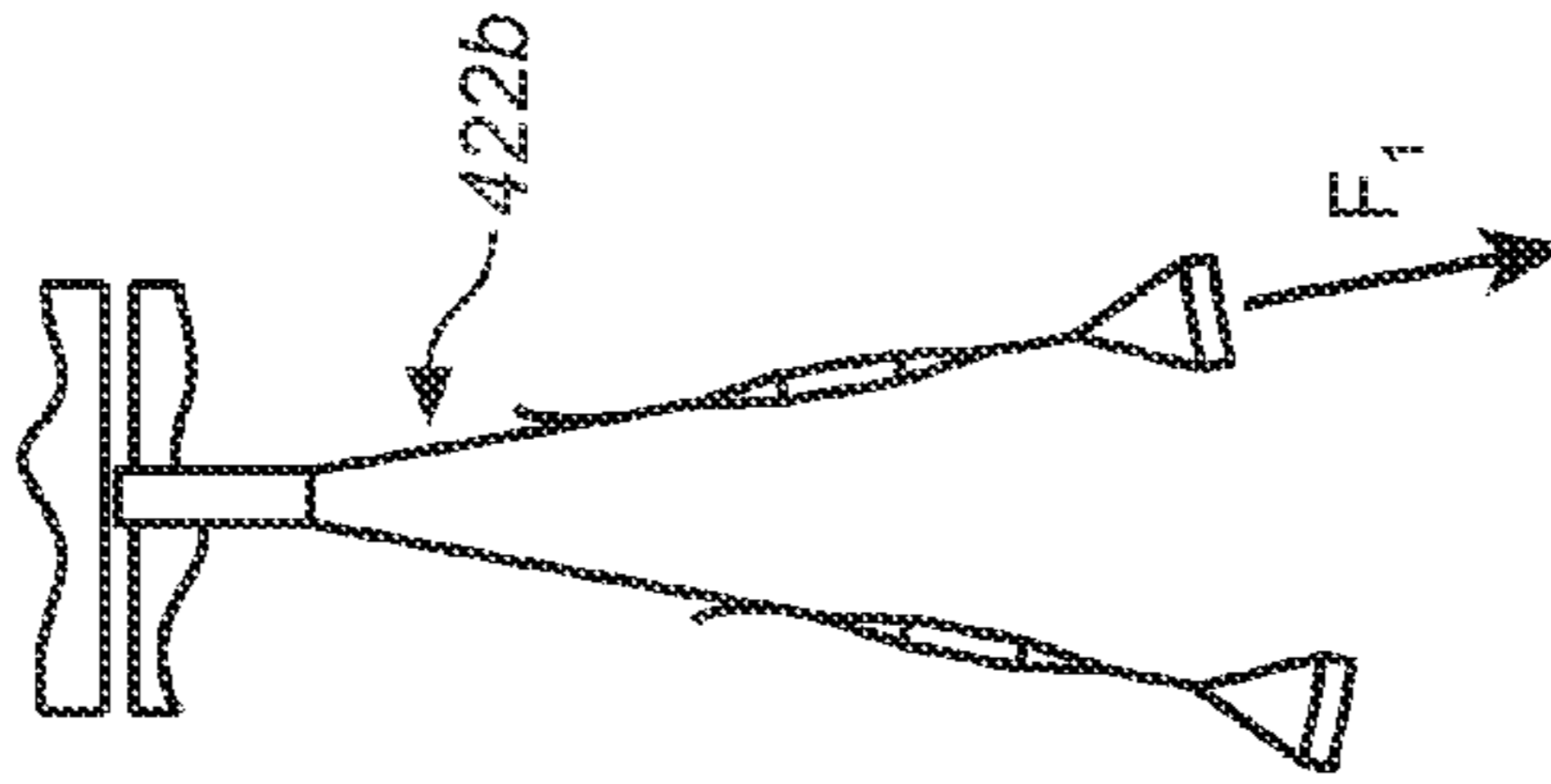

FIG. 12C

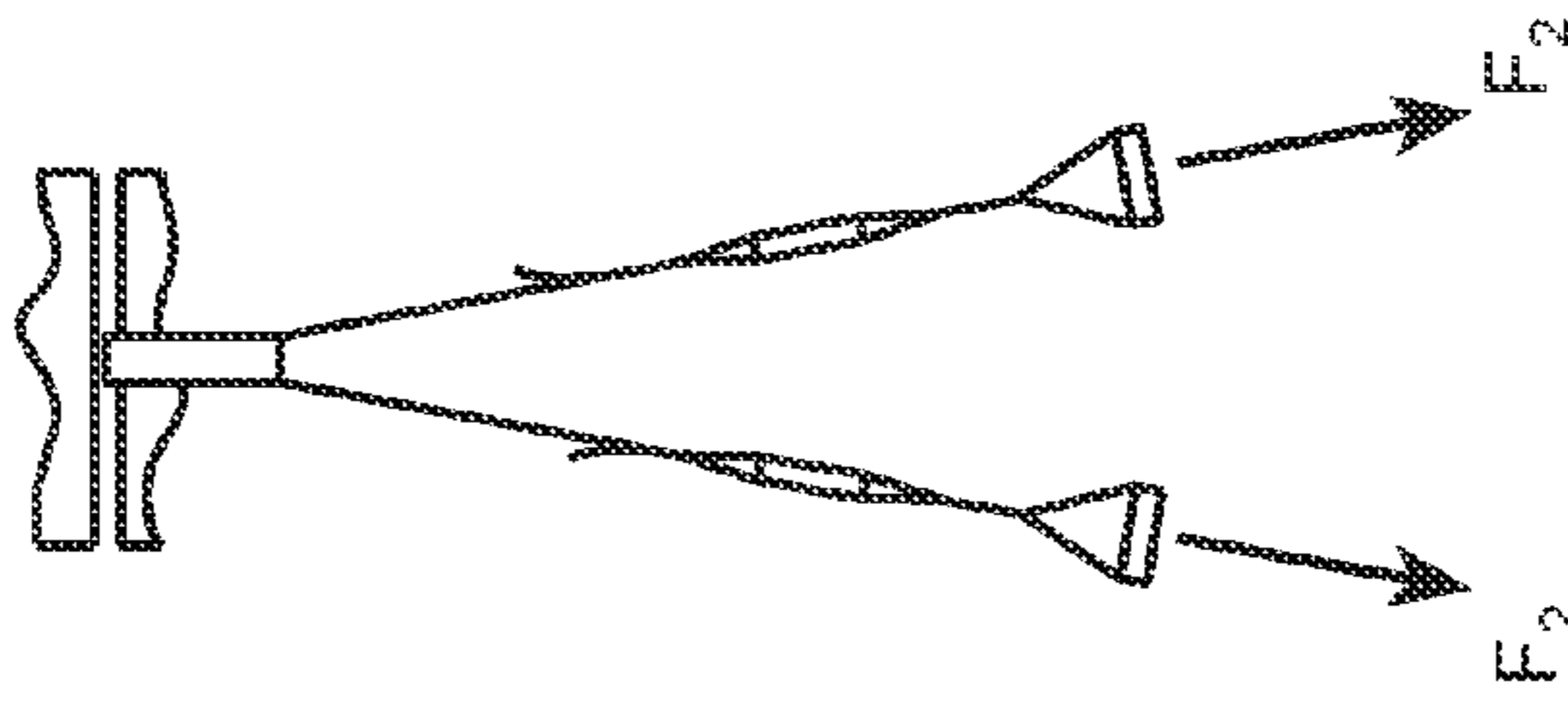

FIG. 12D

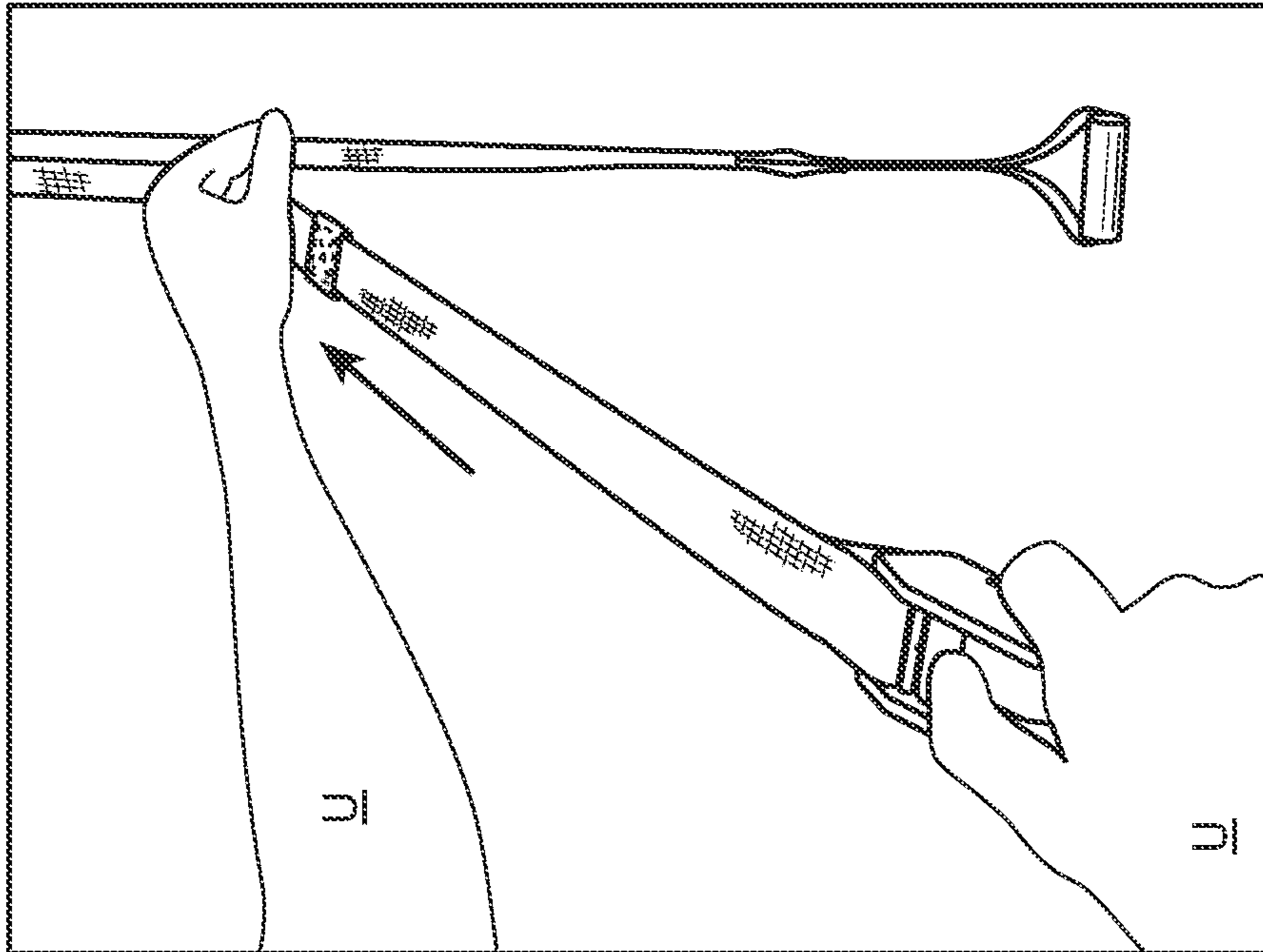

FIG. 12B'

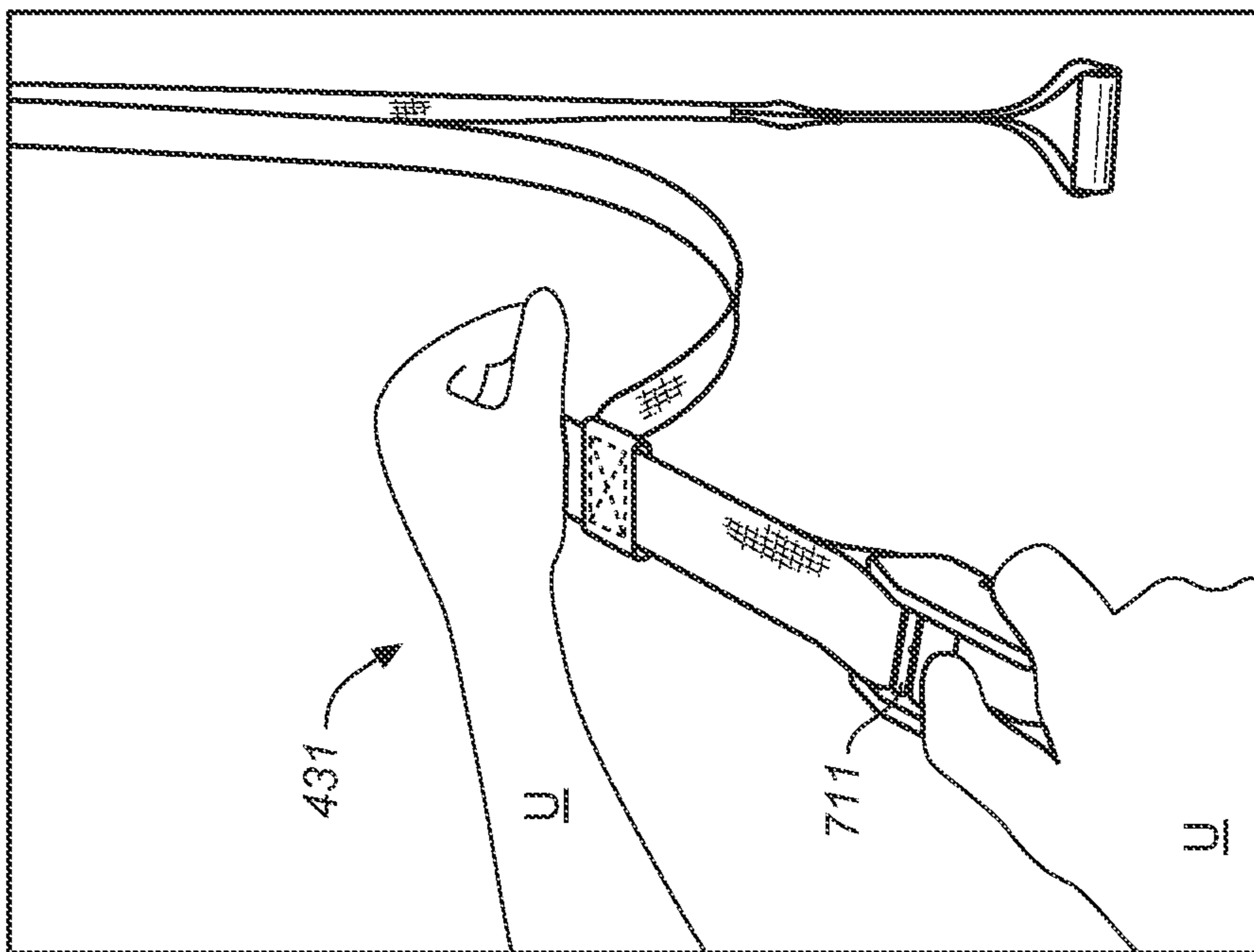

FIG. 12B'

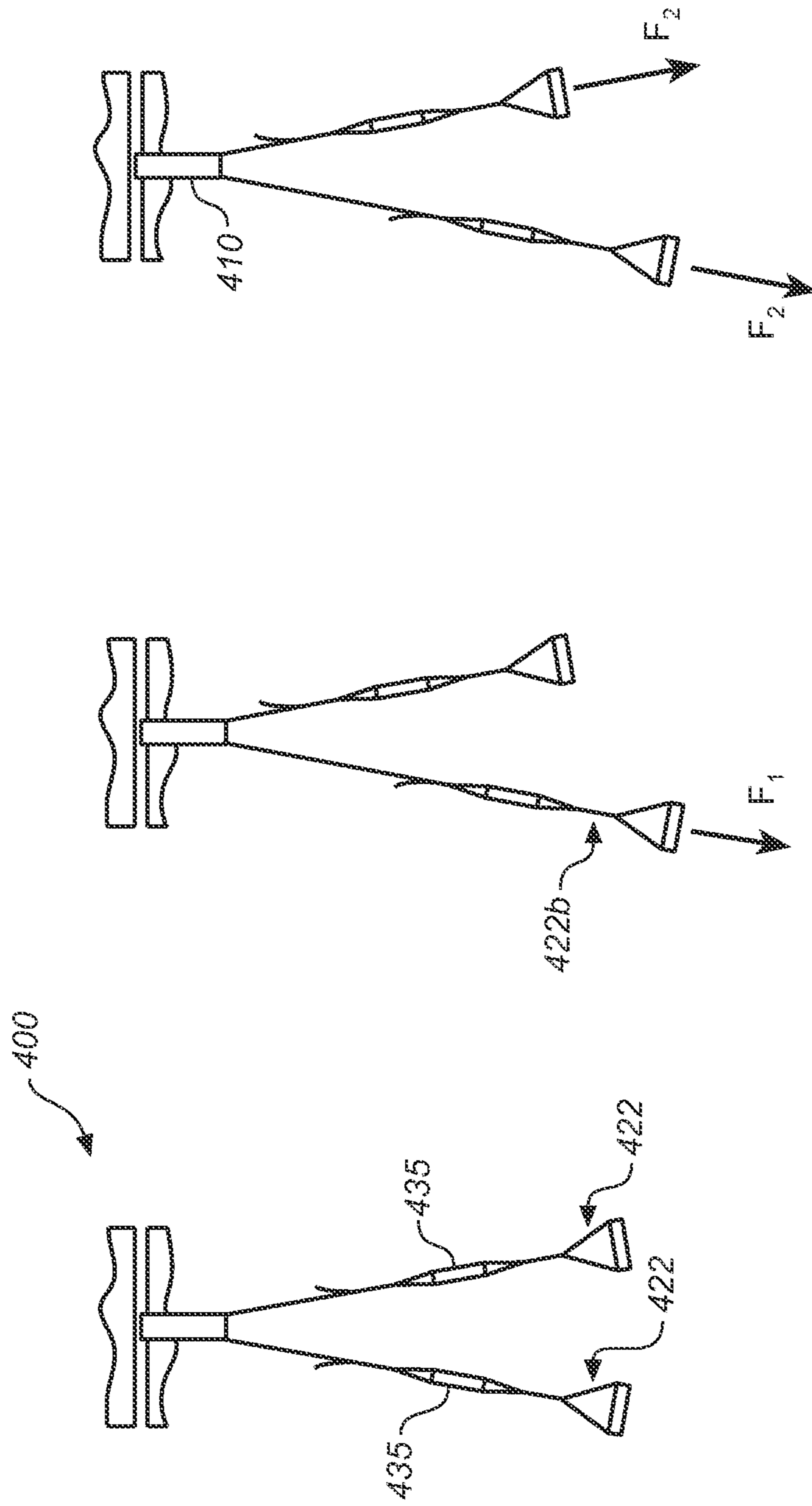

FIG. 13A

FIG. 13B

FIG. 13C

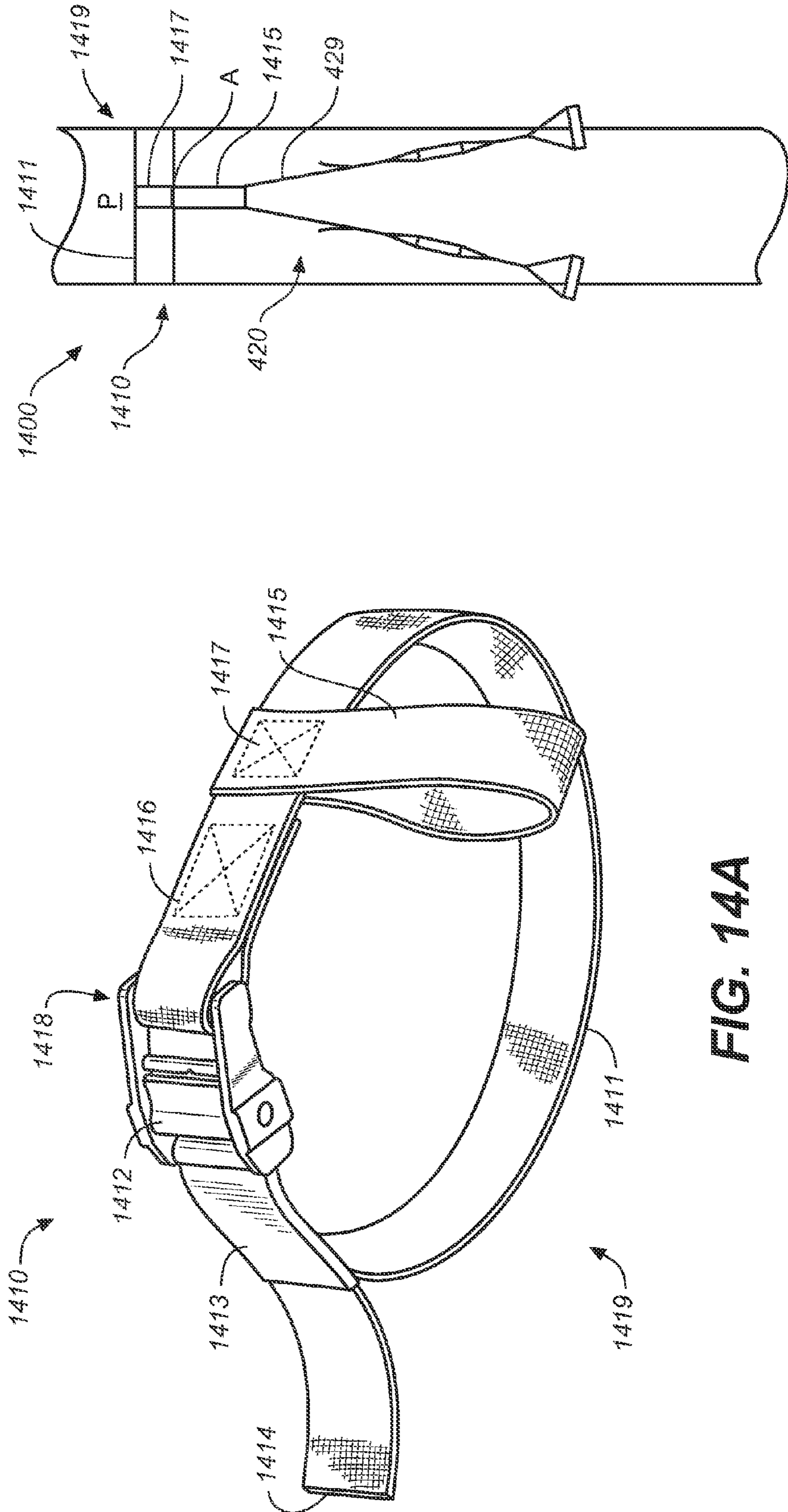

FIG. 14A

FIG. 14B

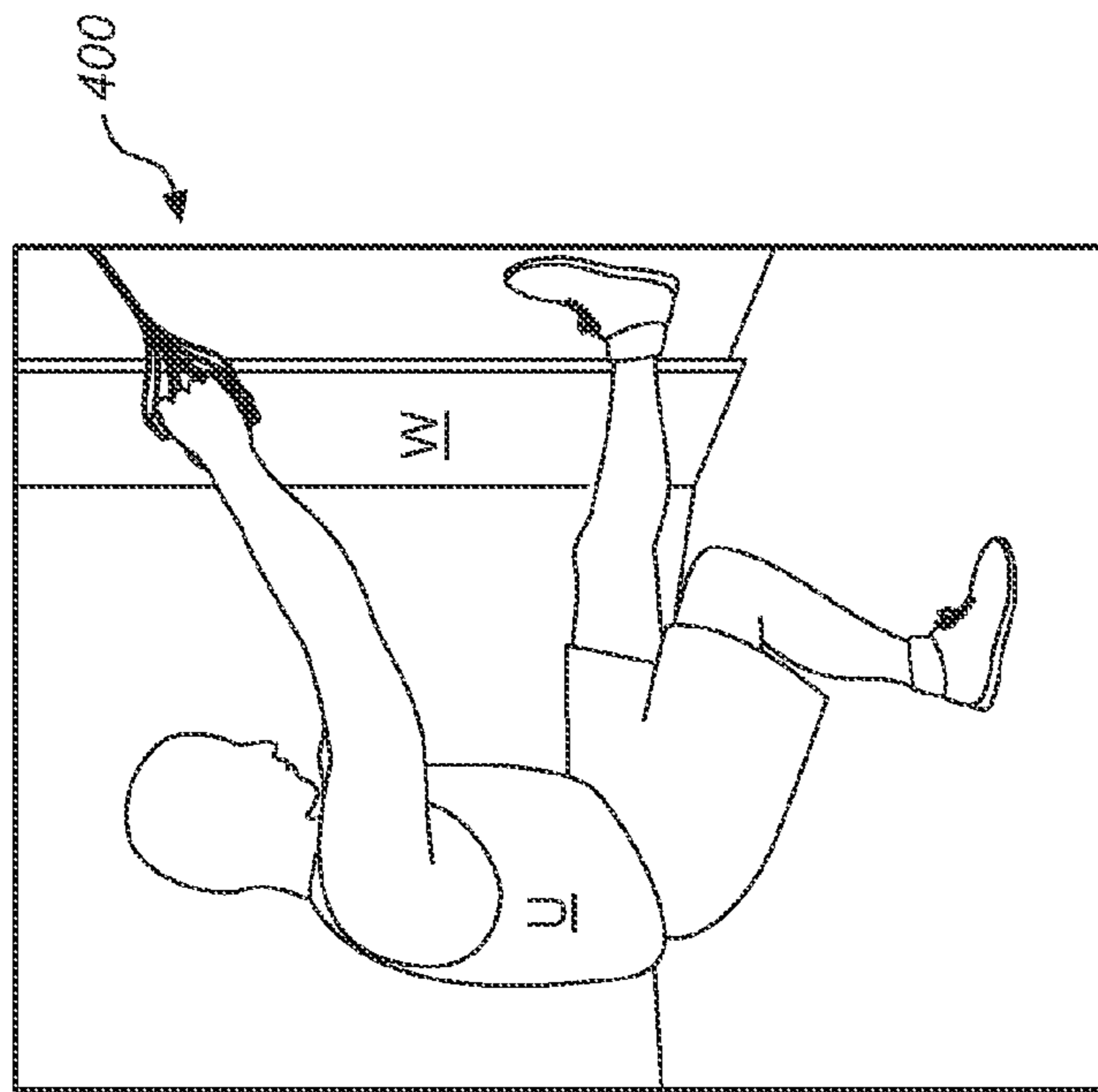

FIG. 15B

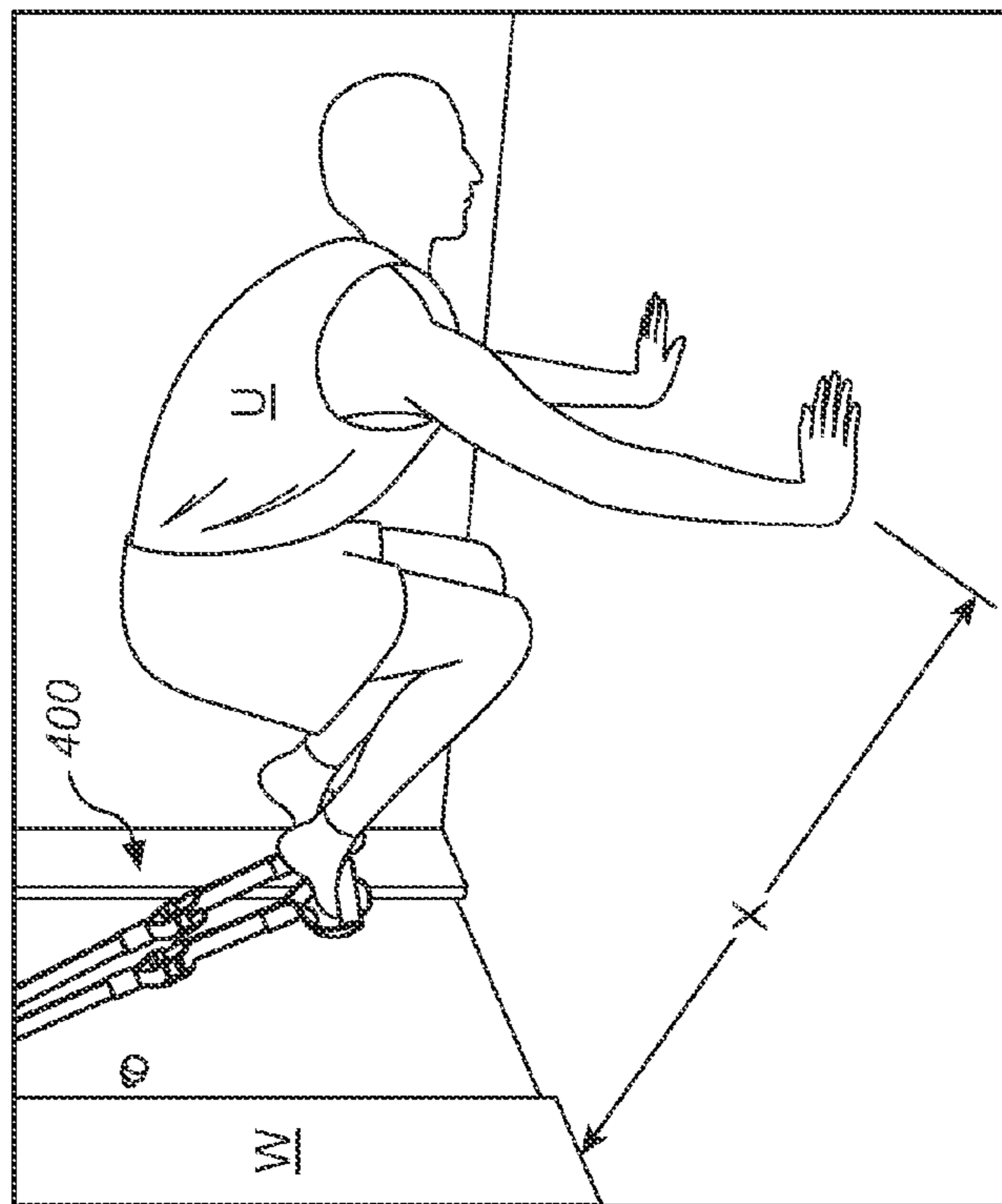

FIG. 15A

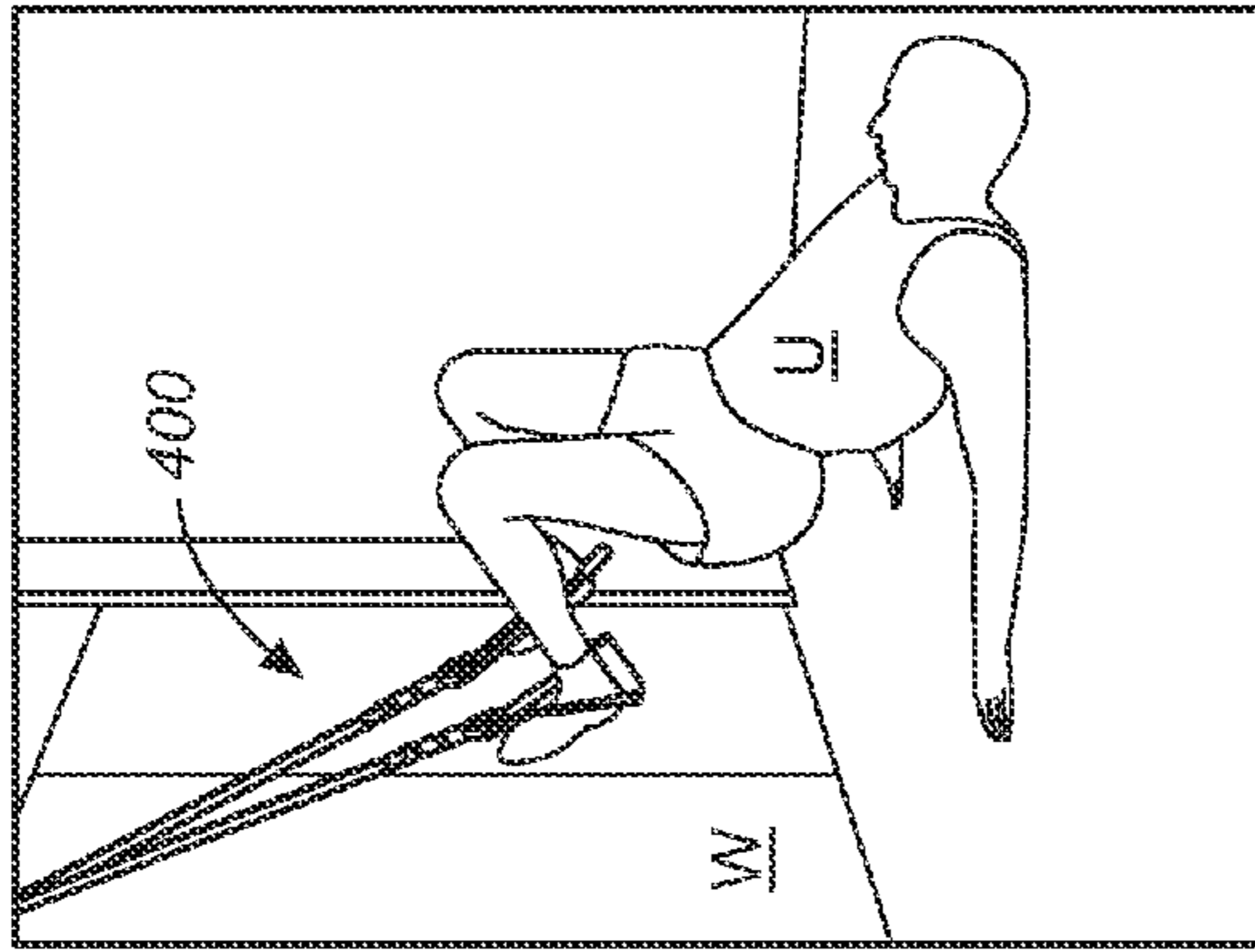

FIG. 15E

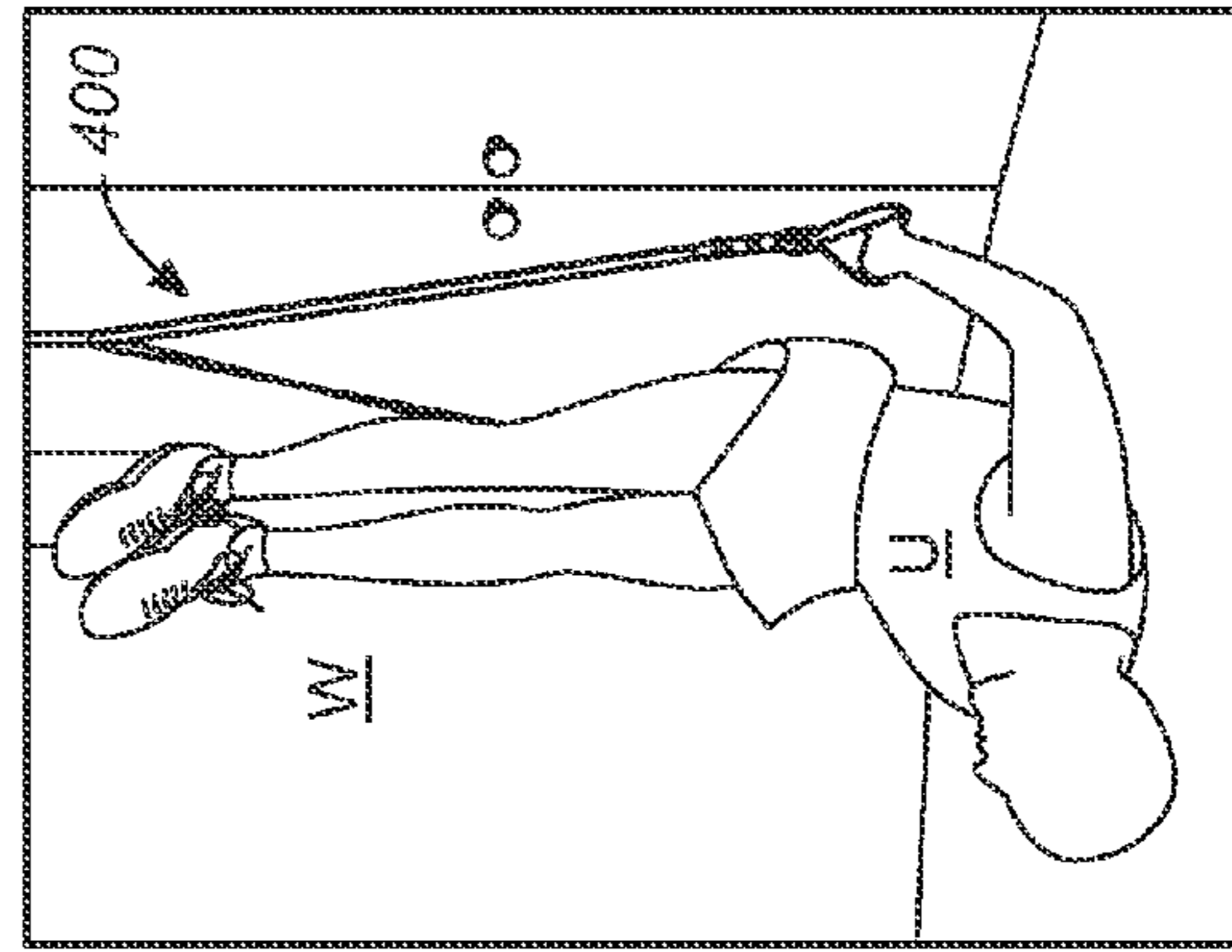

FIG. 15F

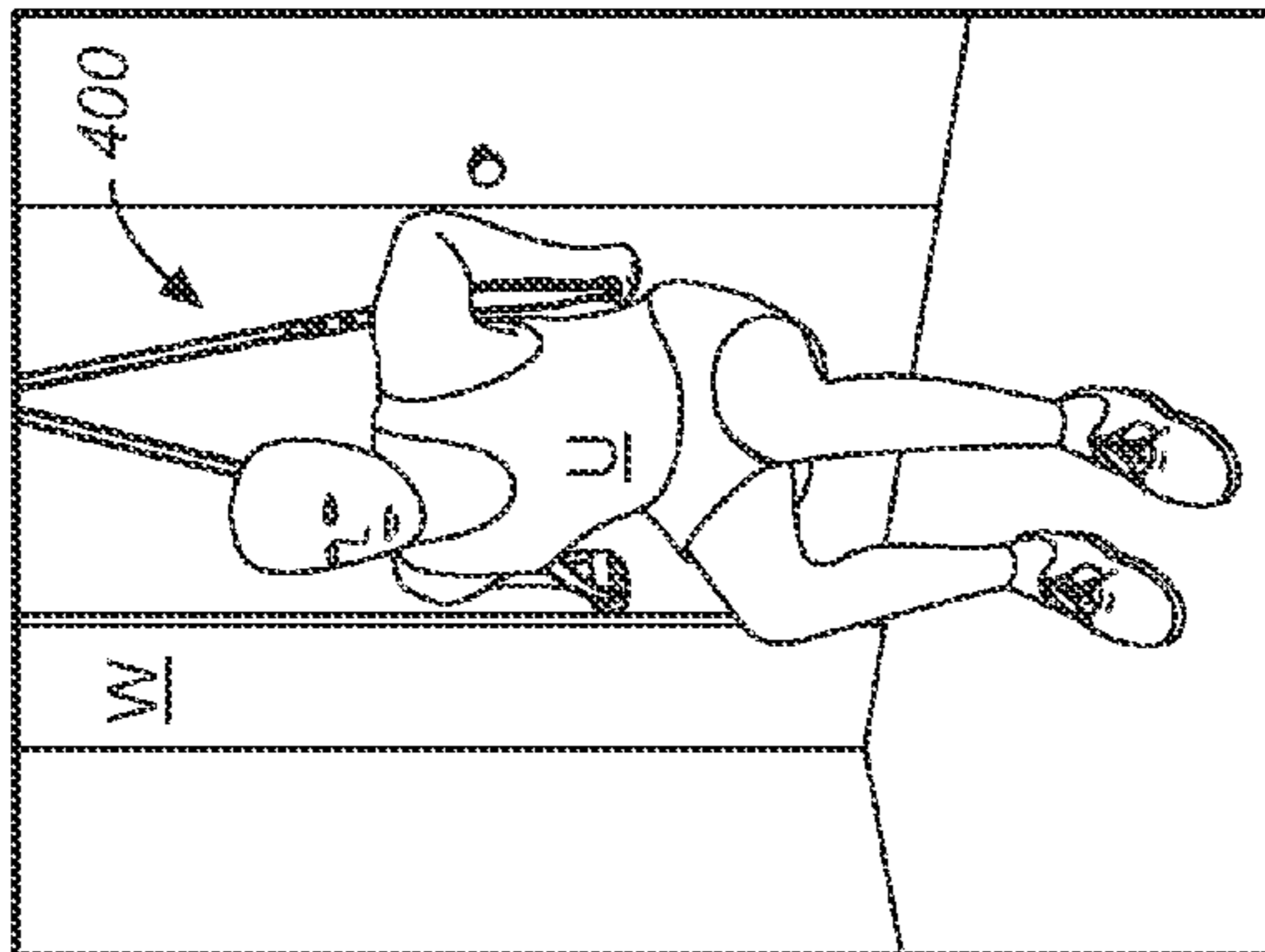

FIG. 15C

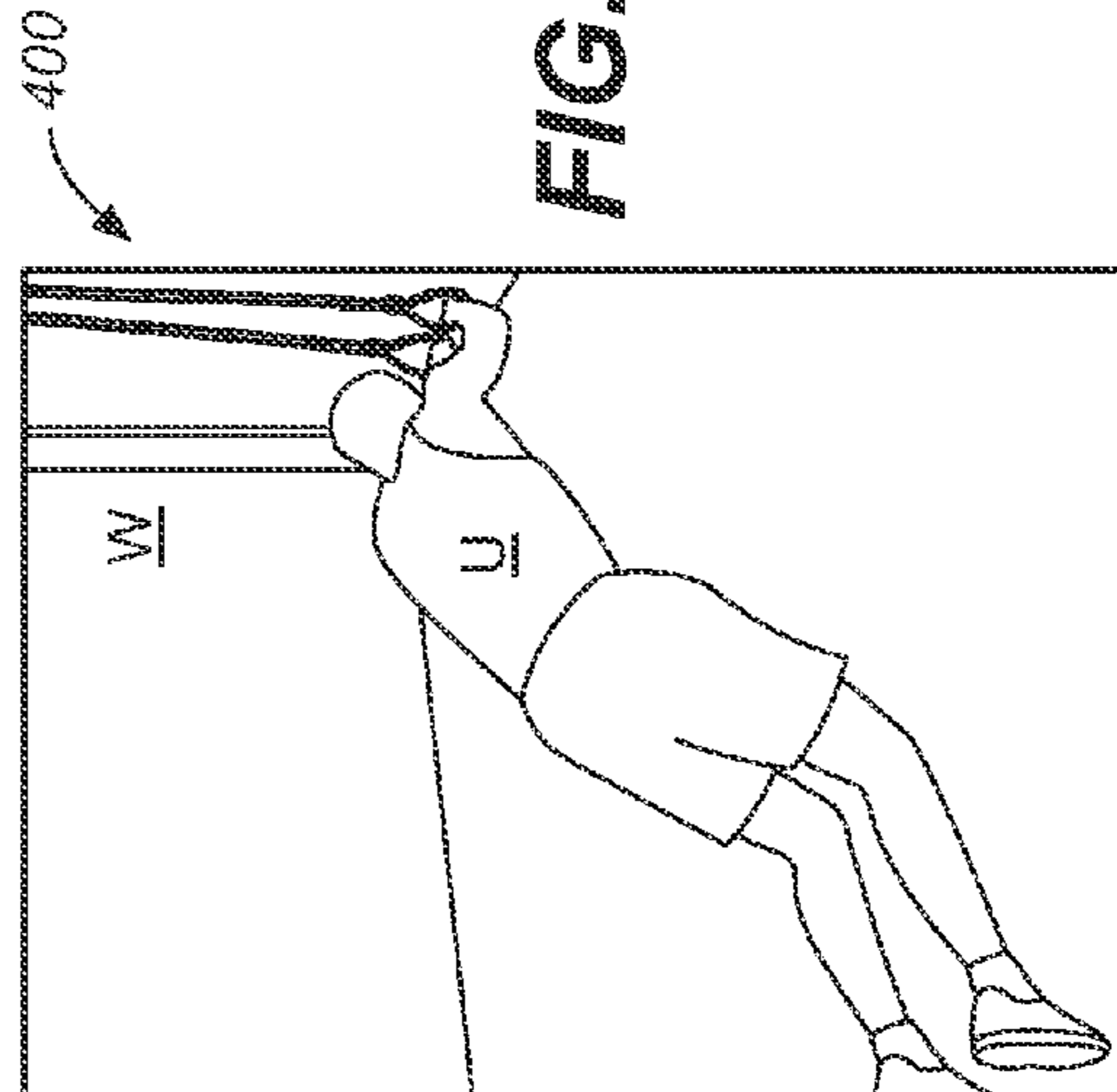

FIG. 15D

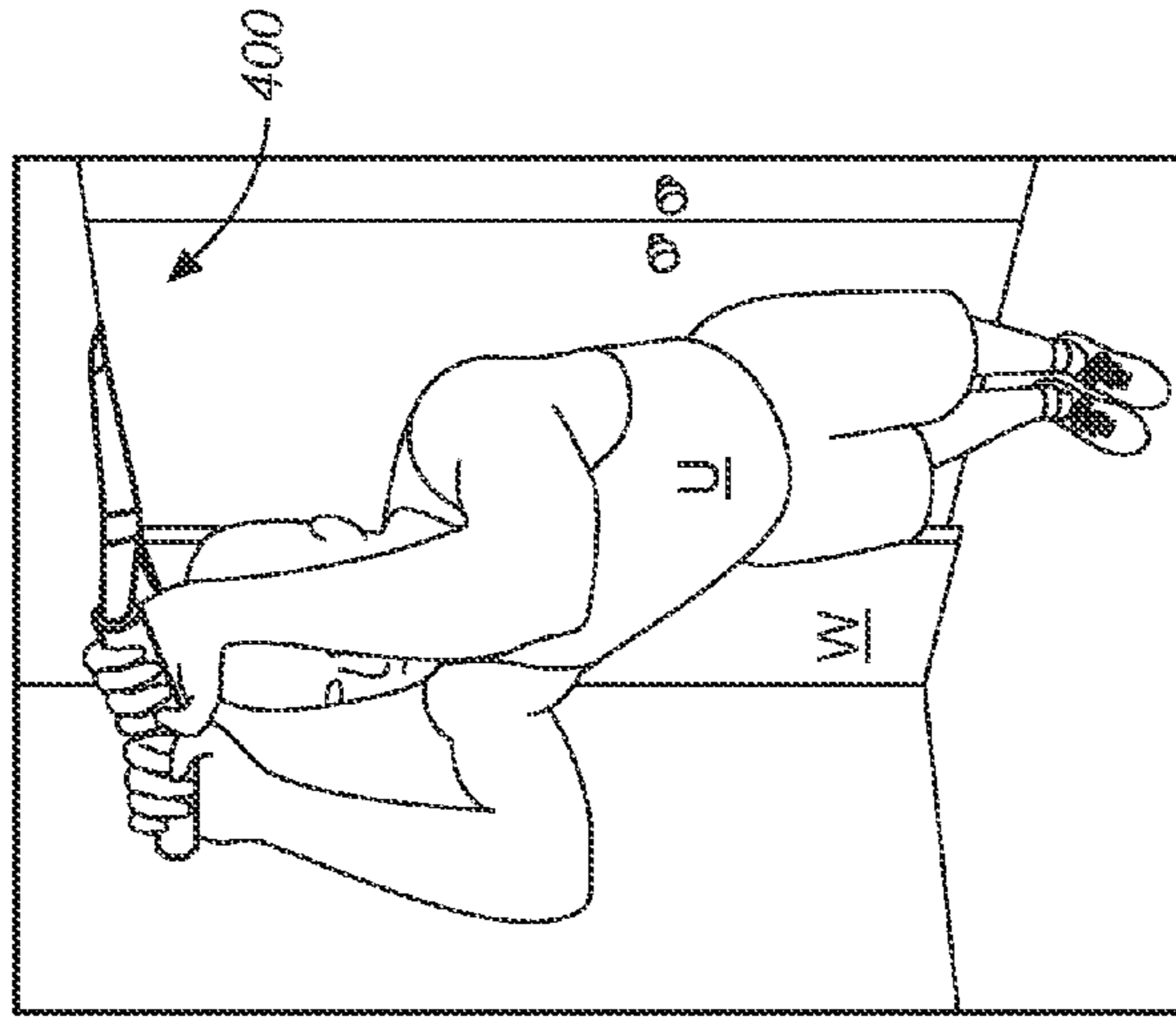

FIG. 15I

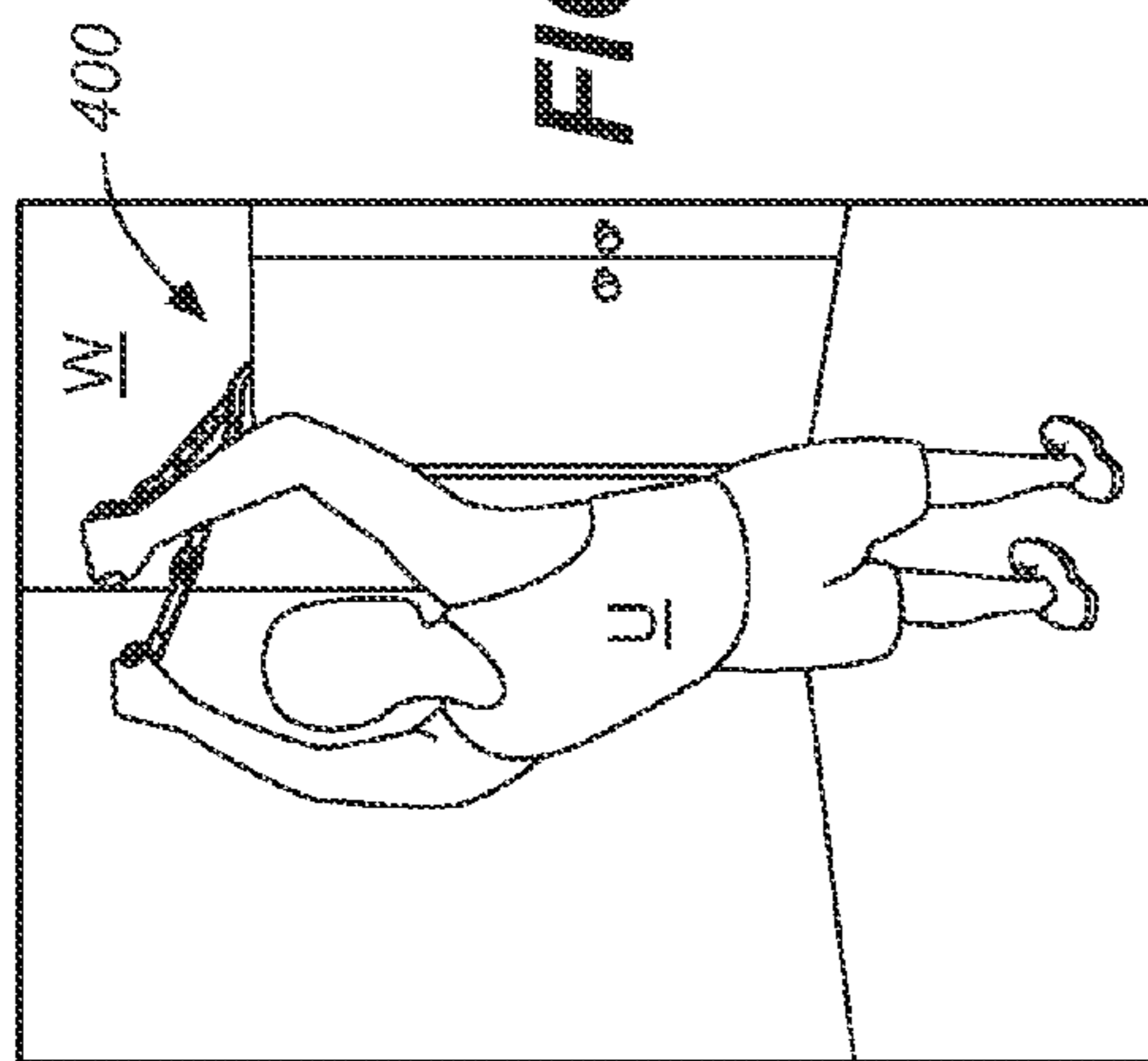

FIG. 15G

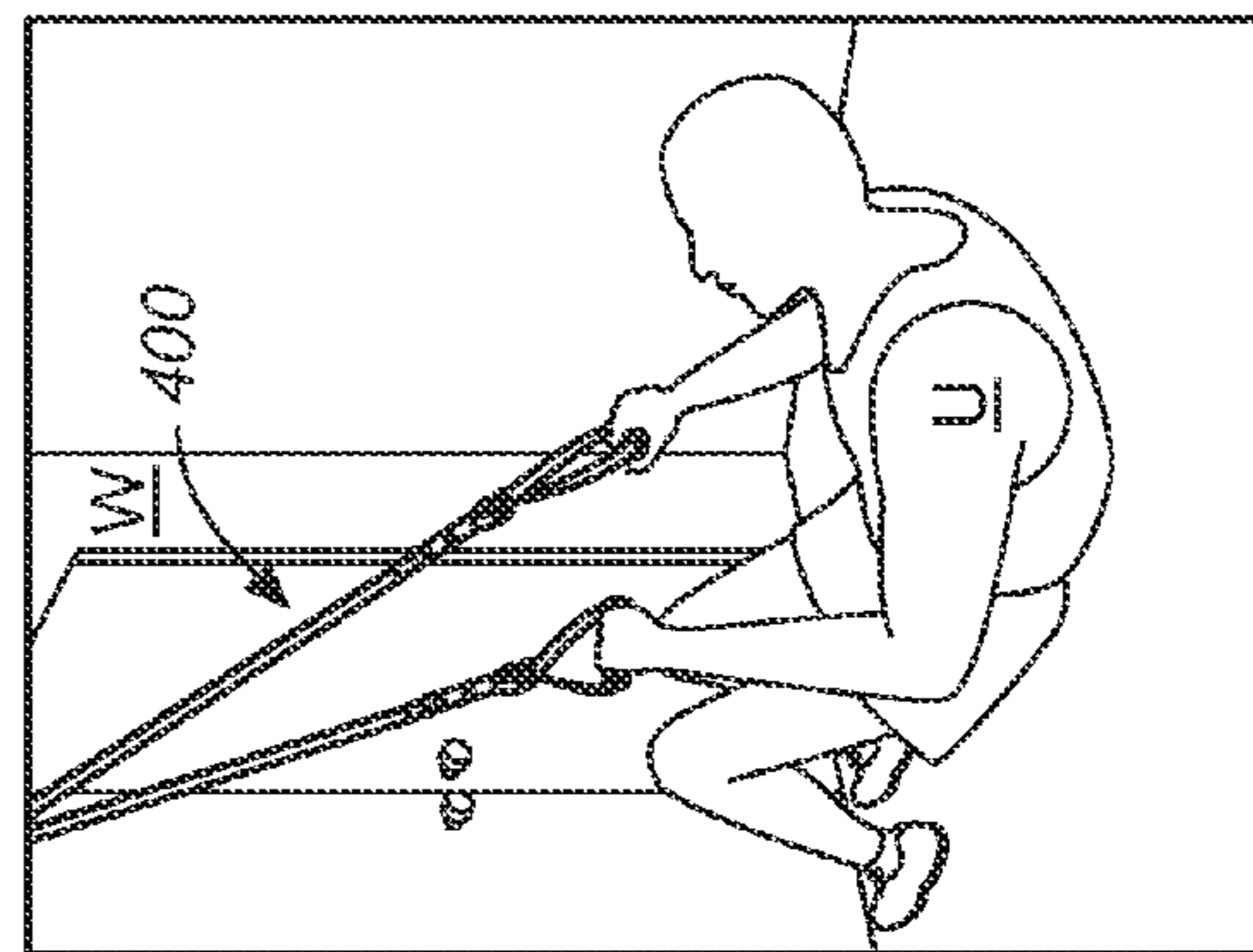

FIG. 15H

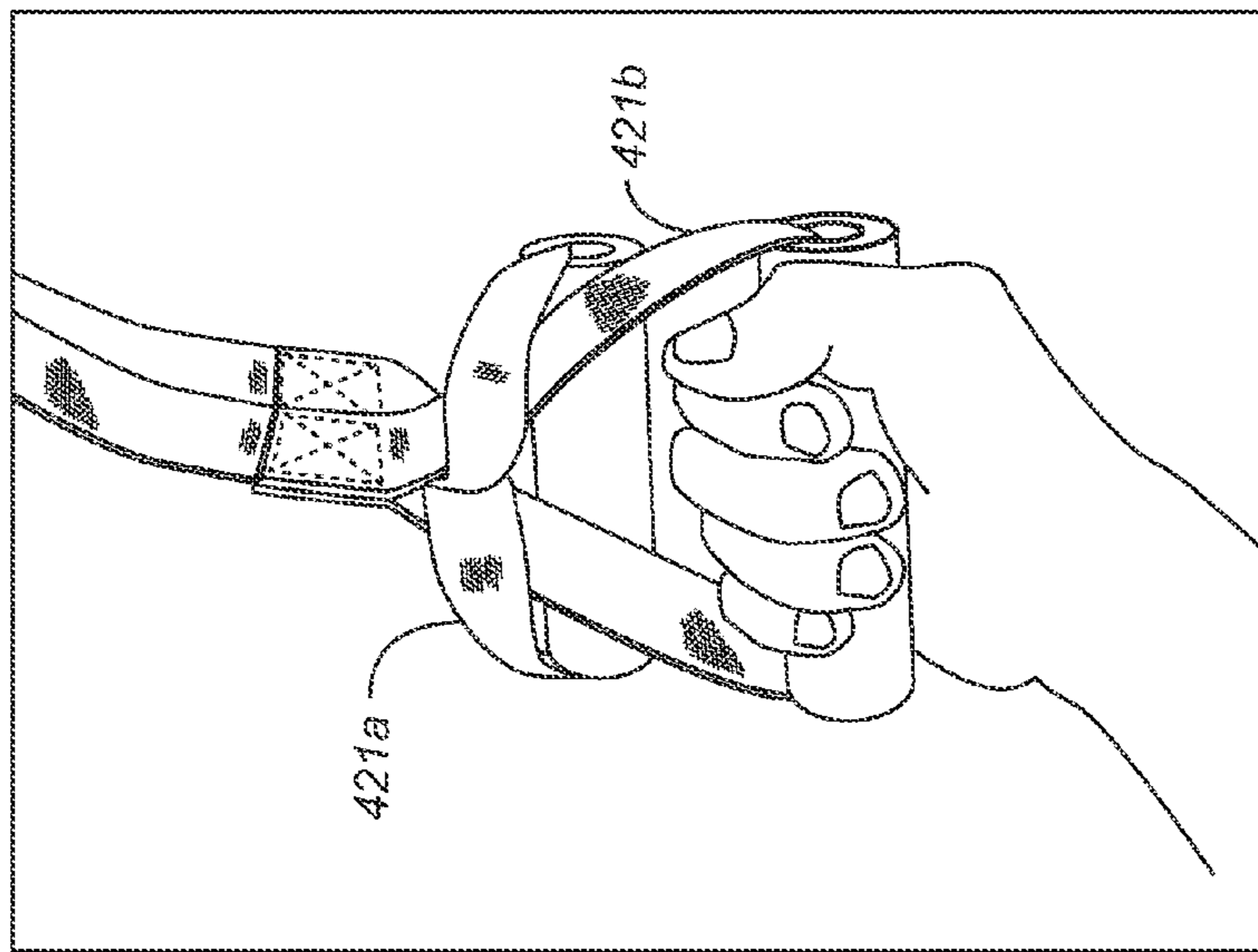

FIG. 16A

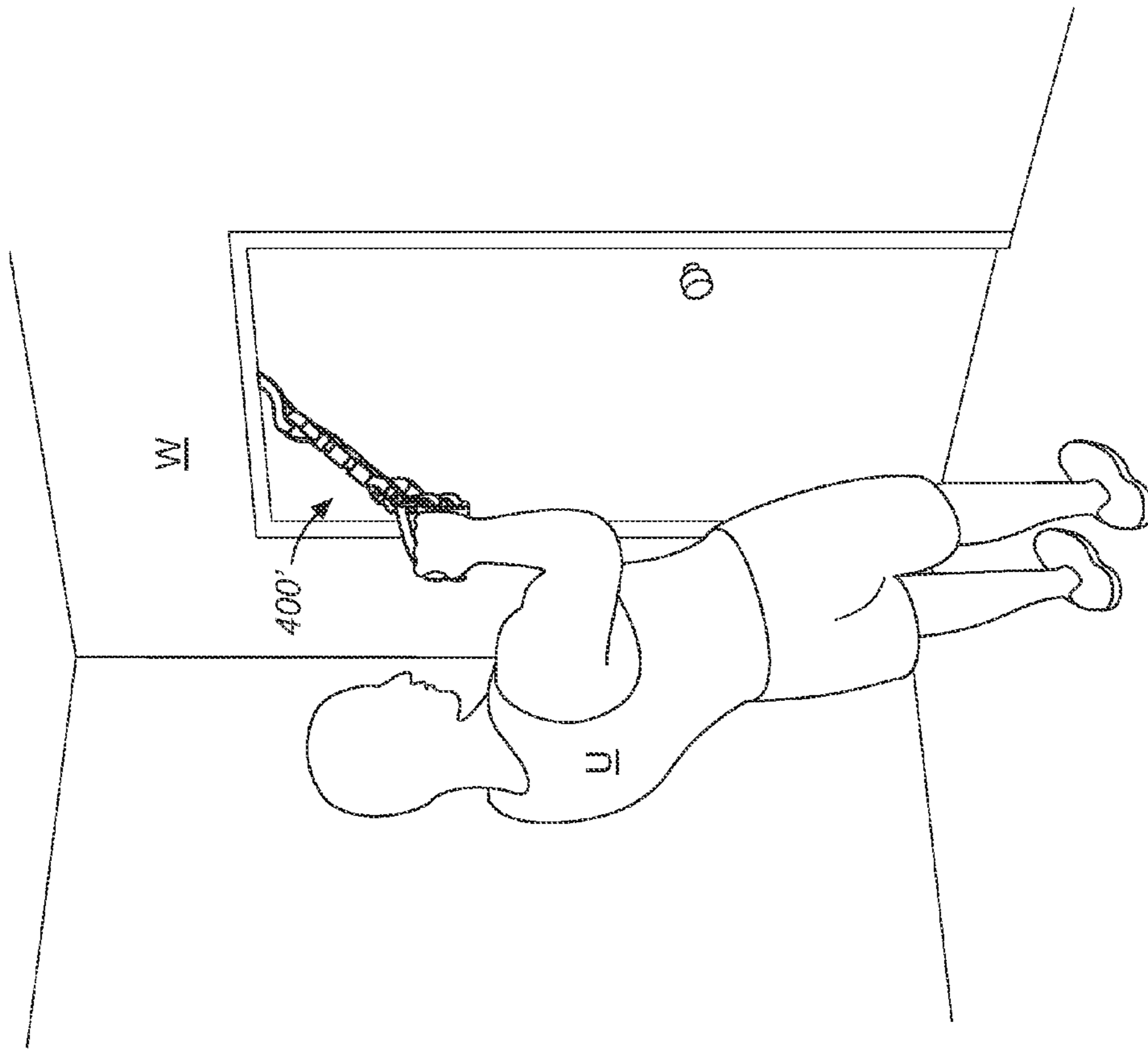
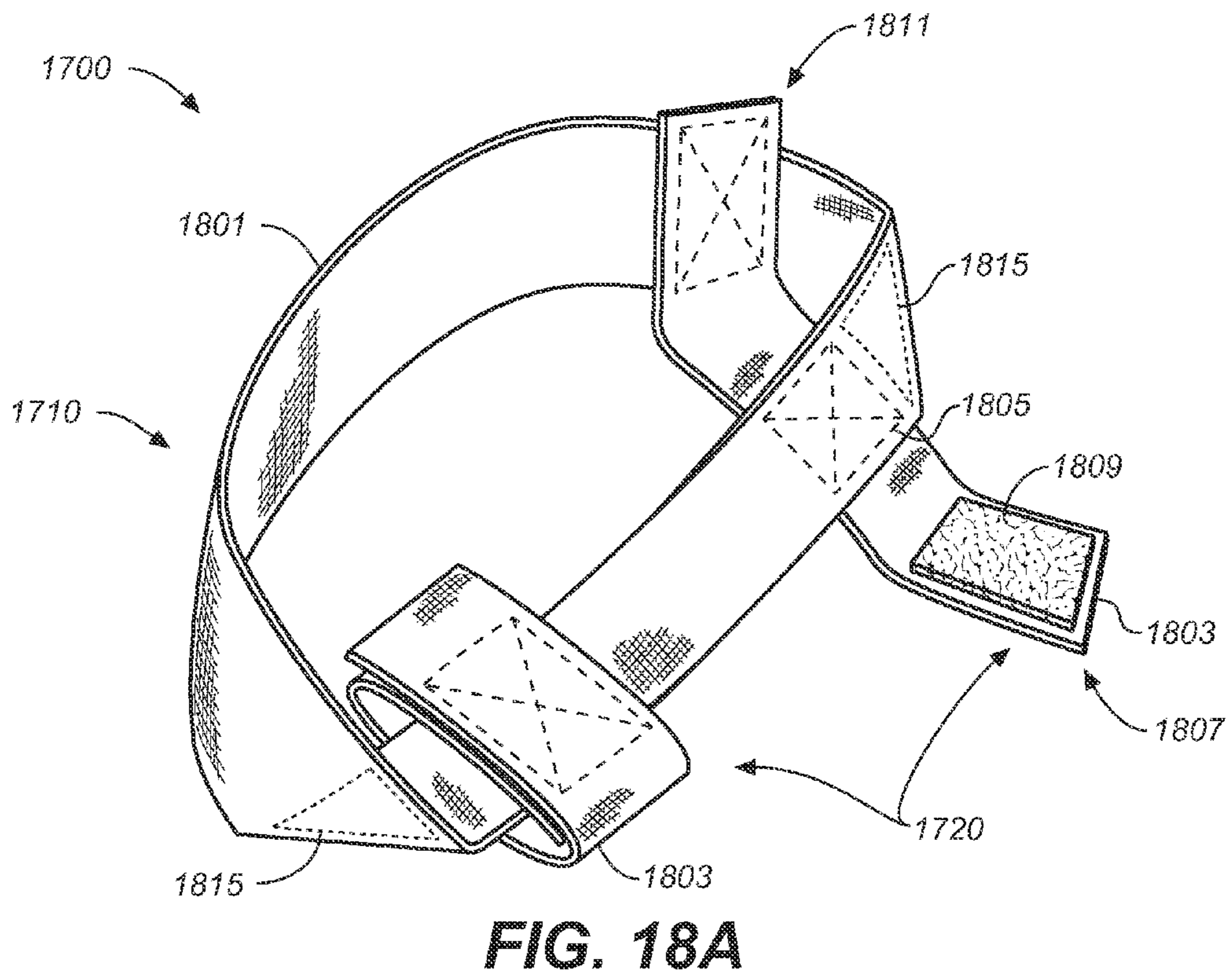
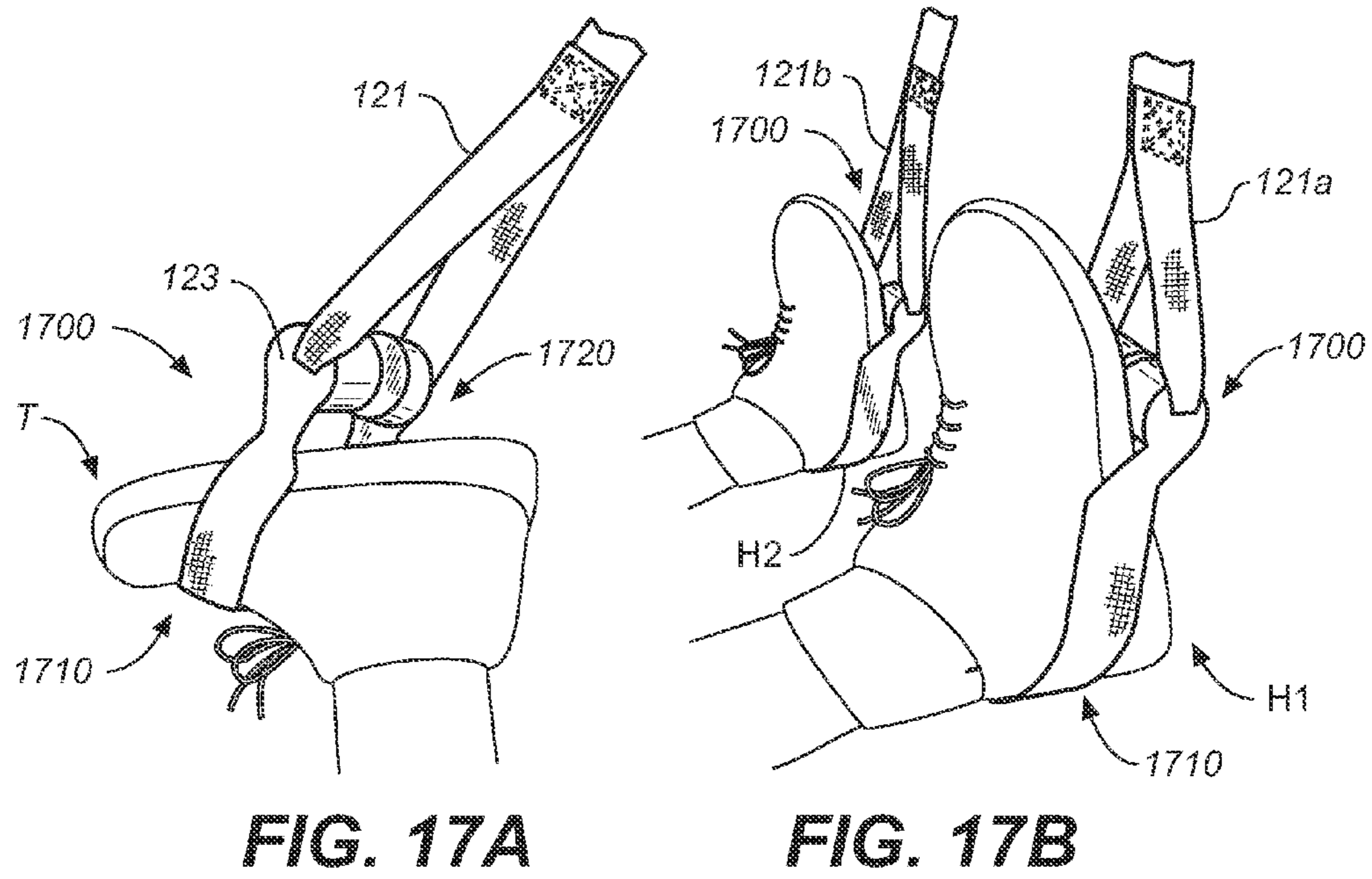

FIG. 16B



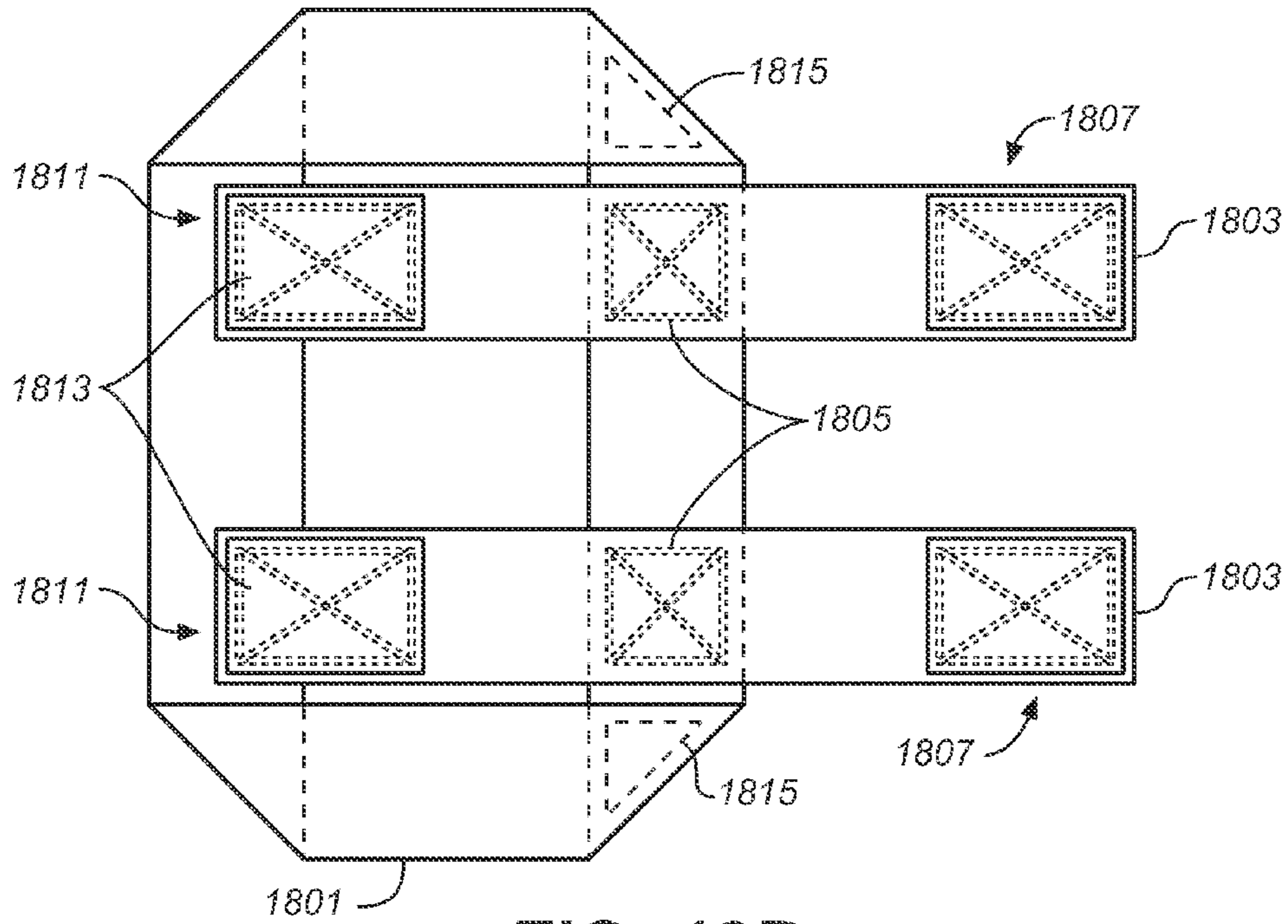

FIG. 18B

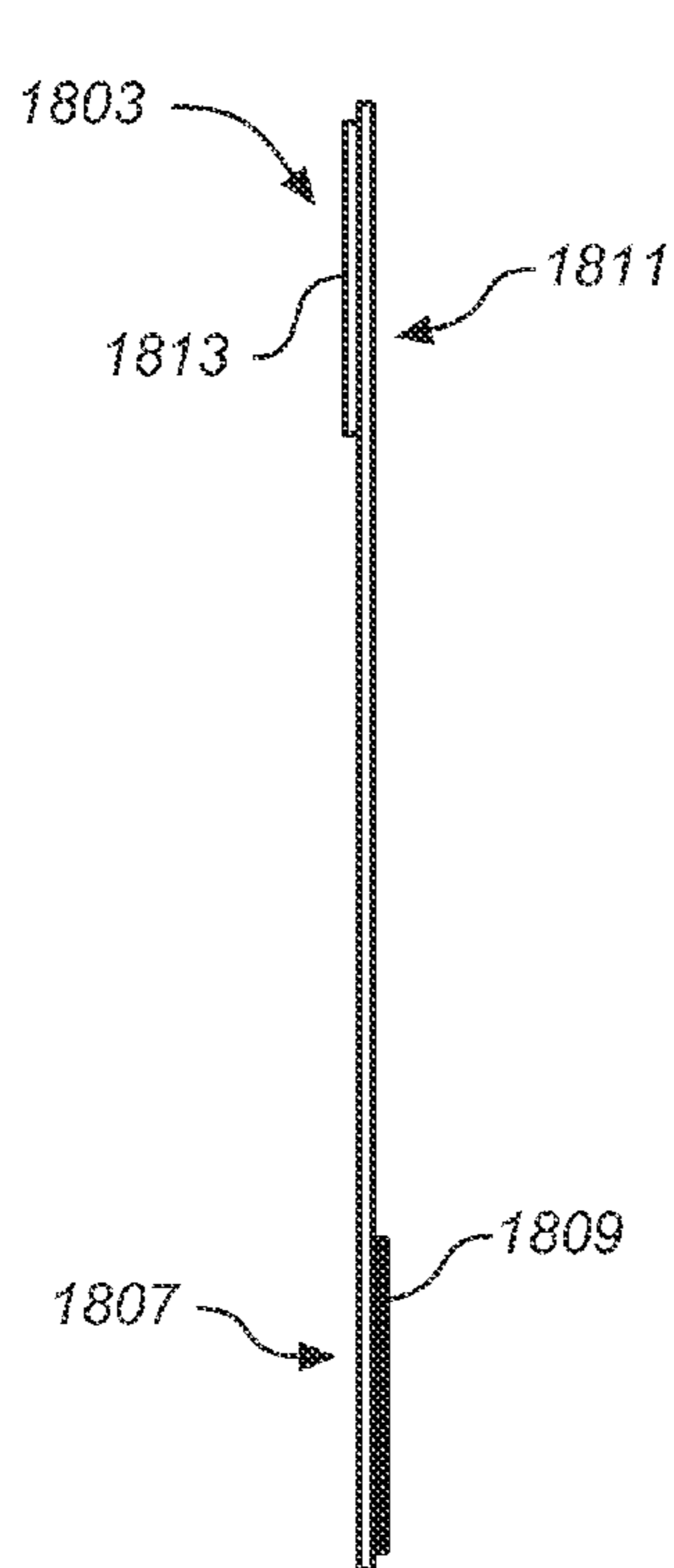

FIG. 18C

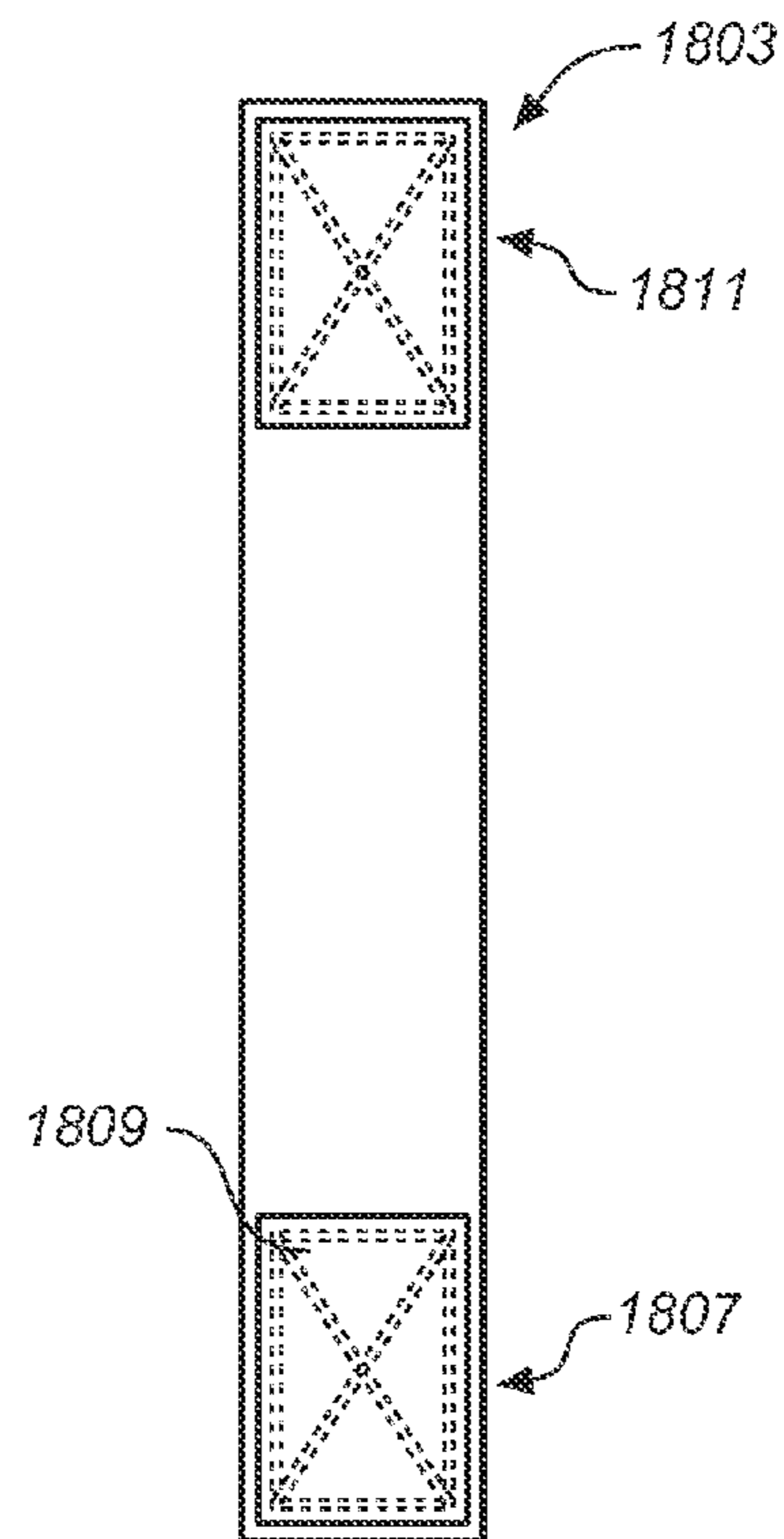

FIG. 18D

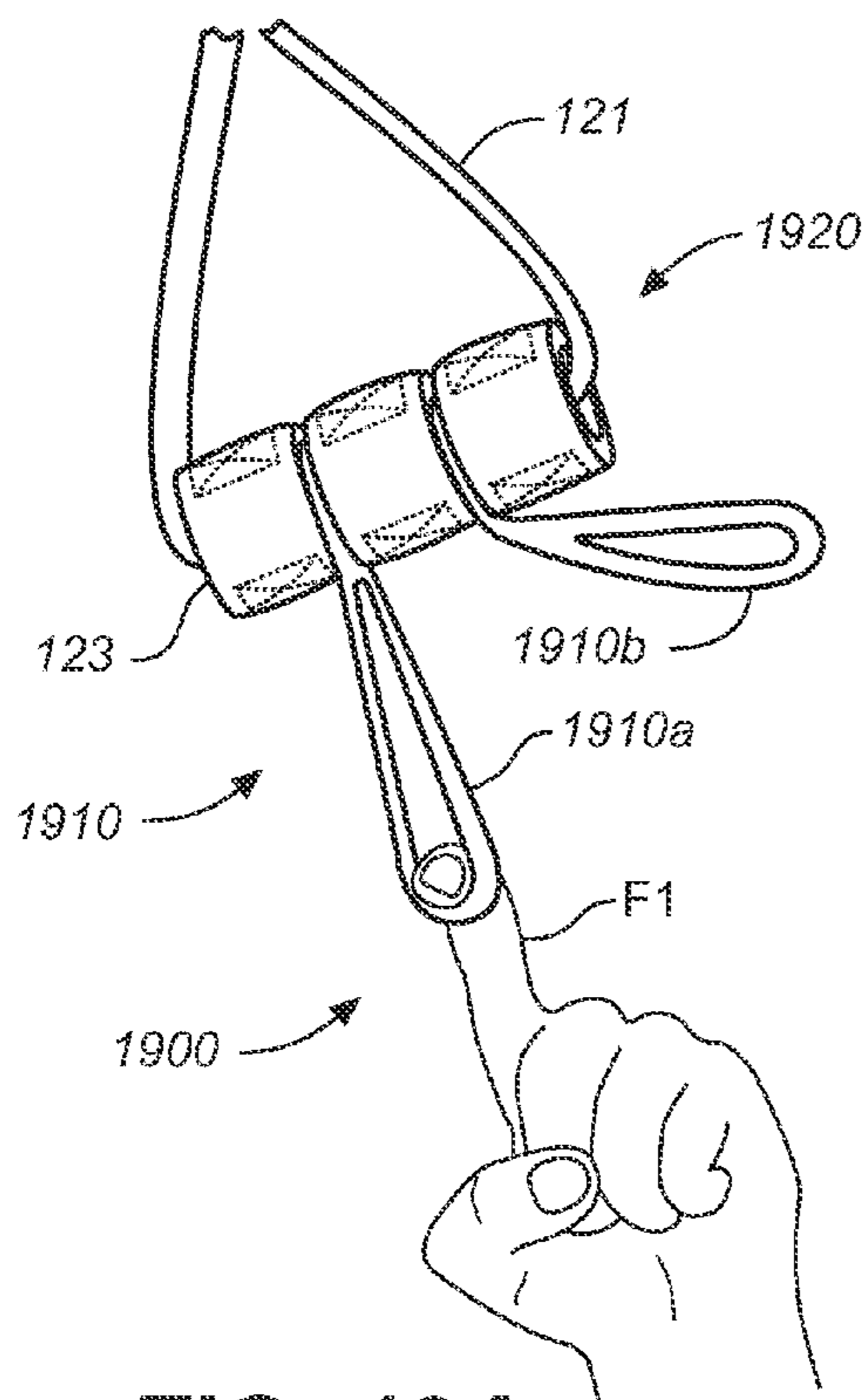

FIG. 19A

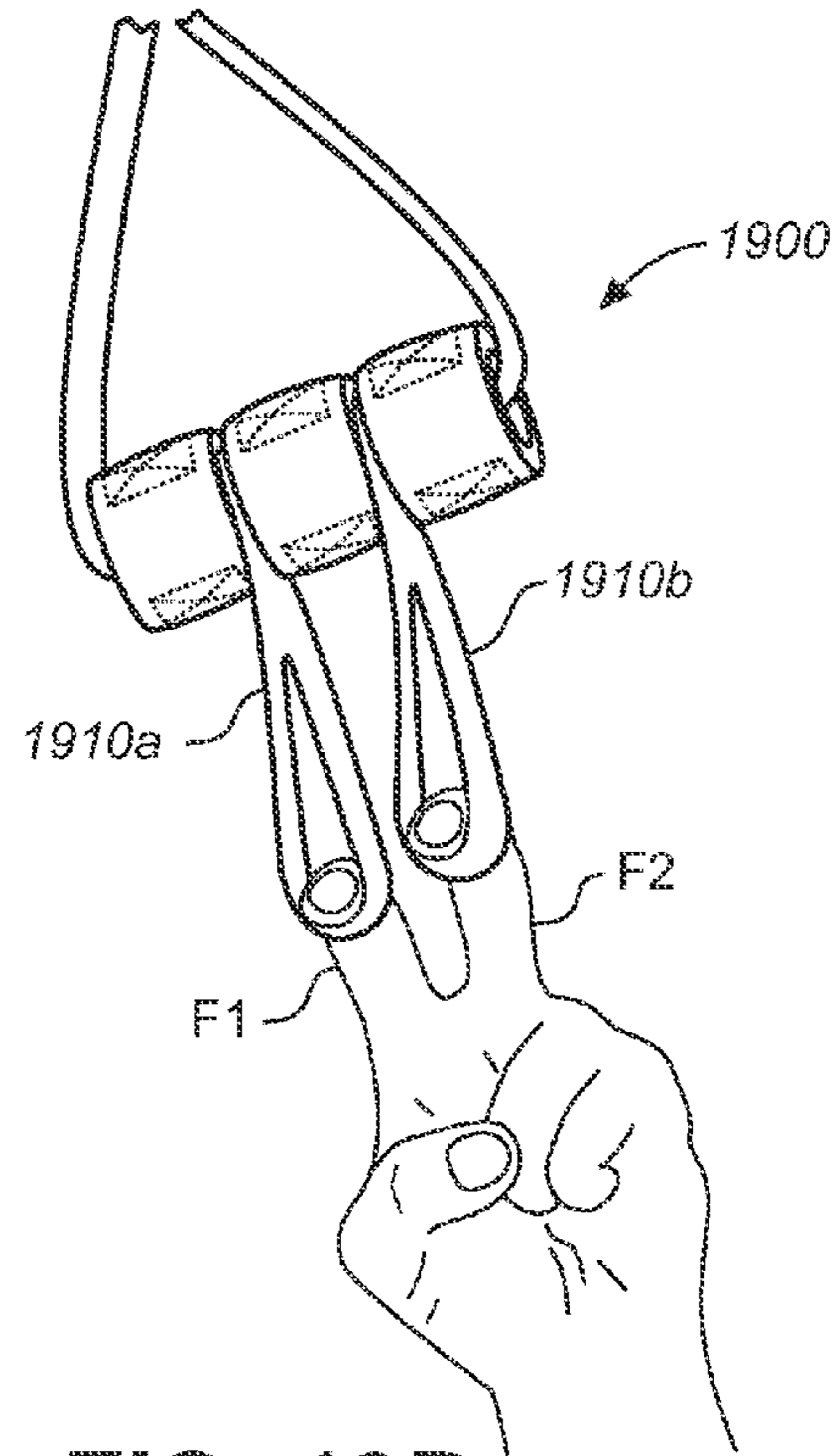

FIG. 19B

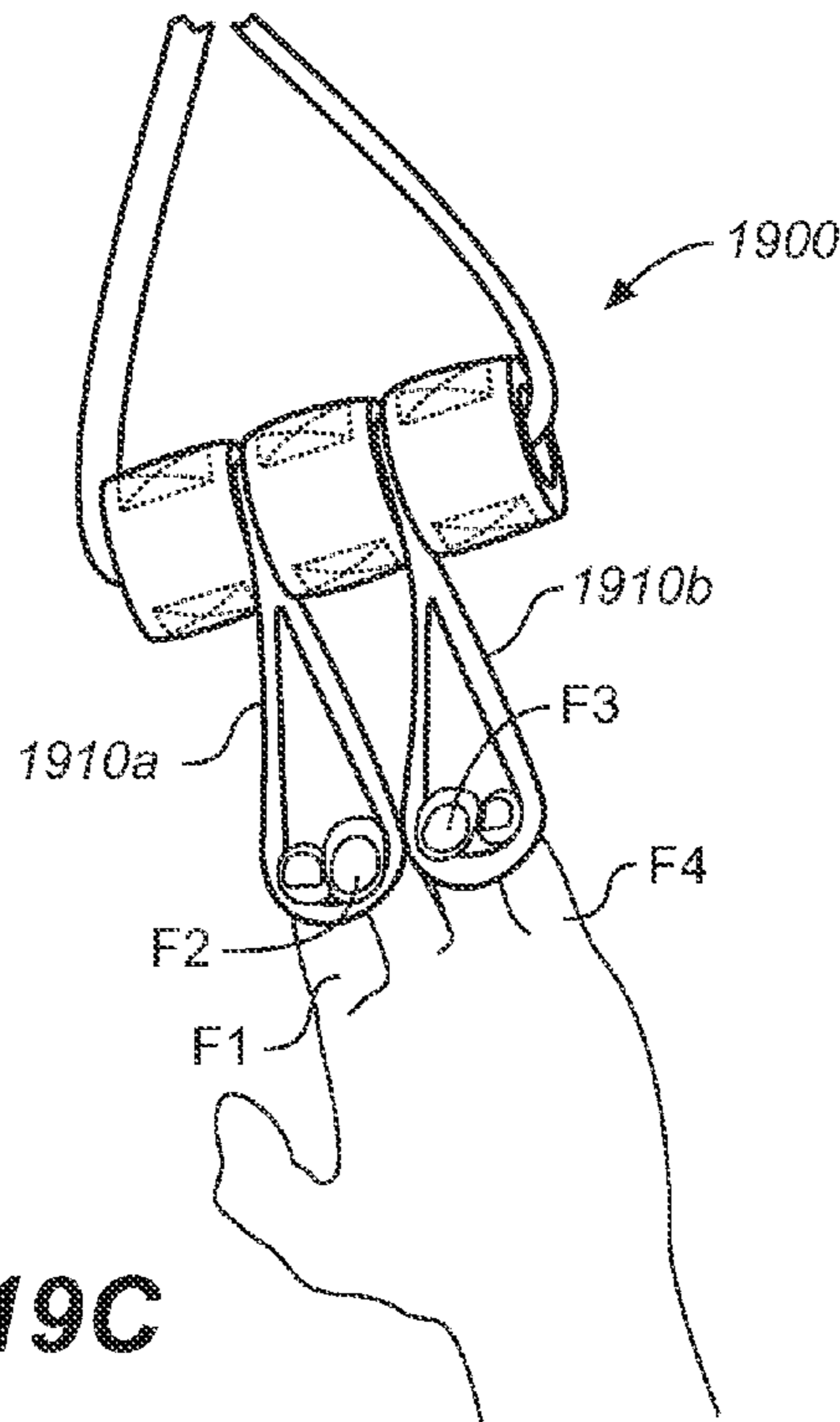

FIG. 19C

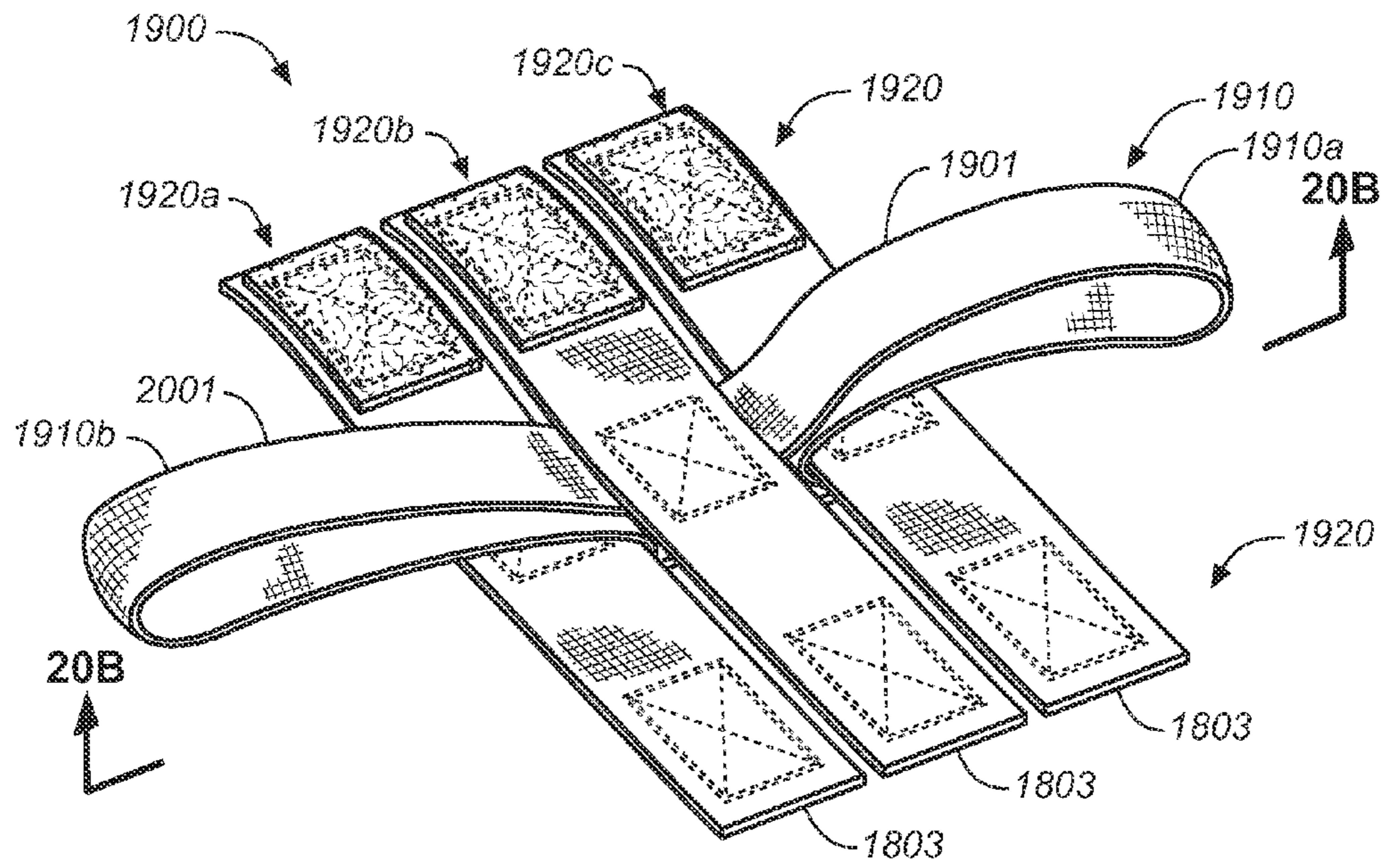

FIG. 20A

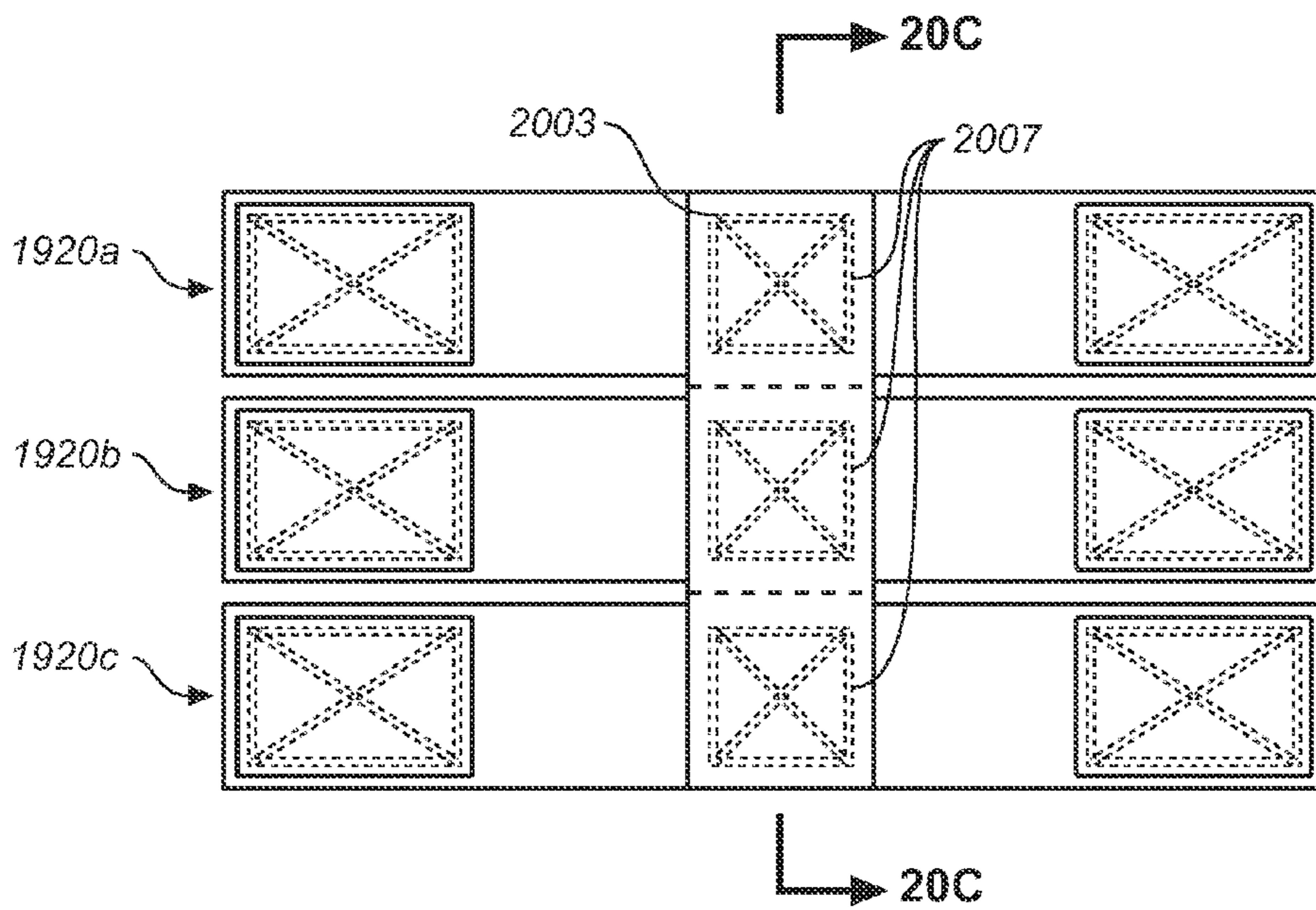

FIG. 20B

FIG. 20C

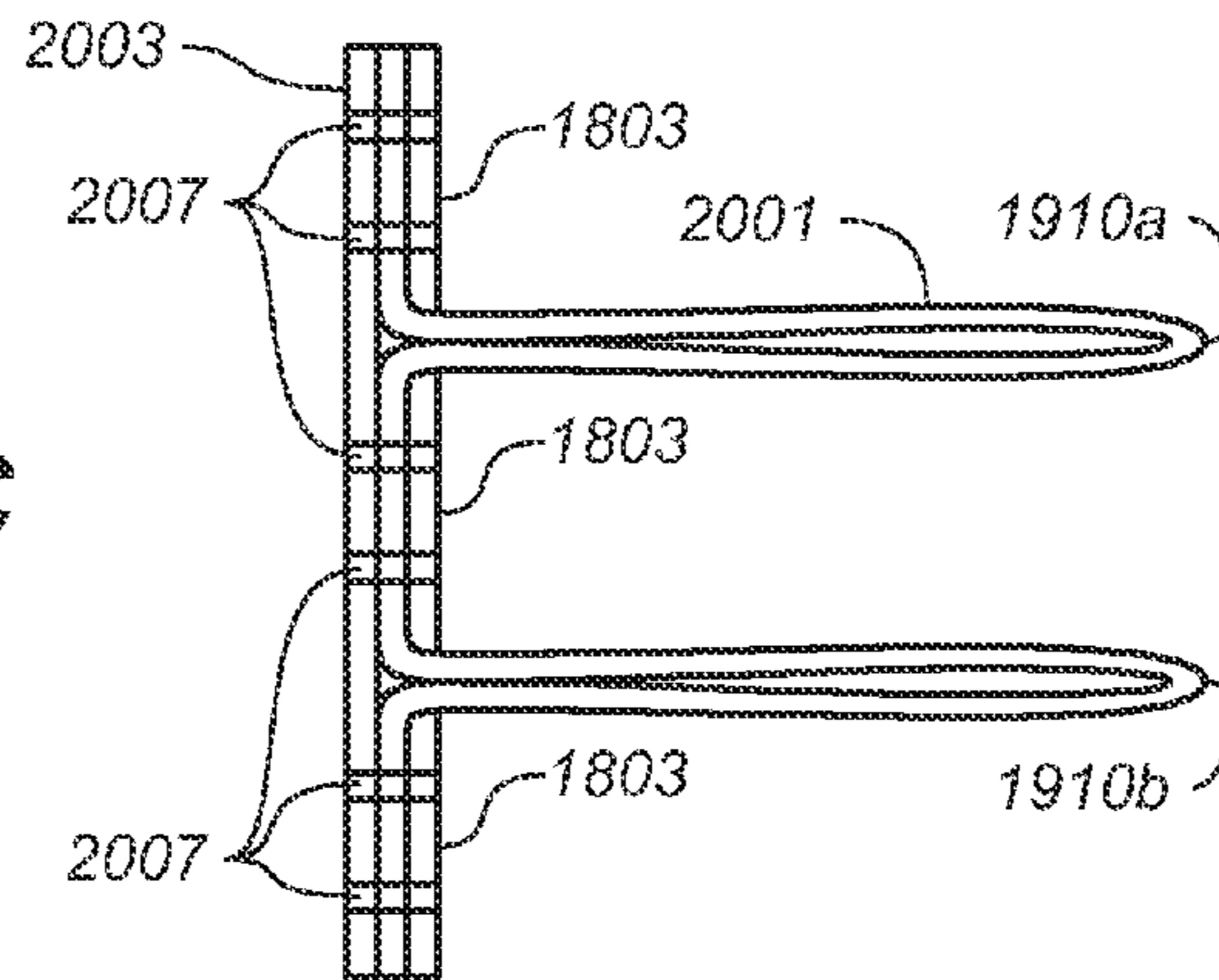

FIG. 21A

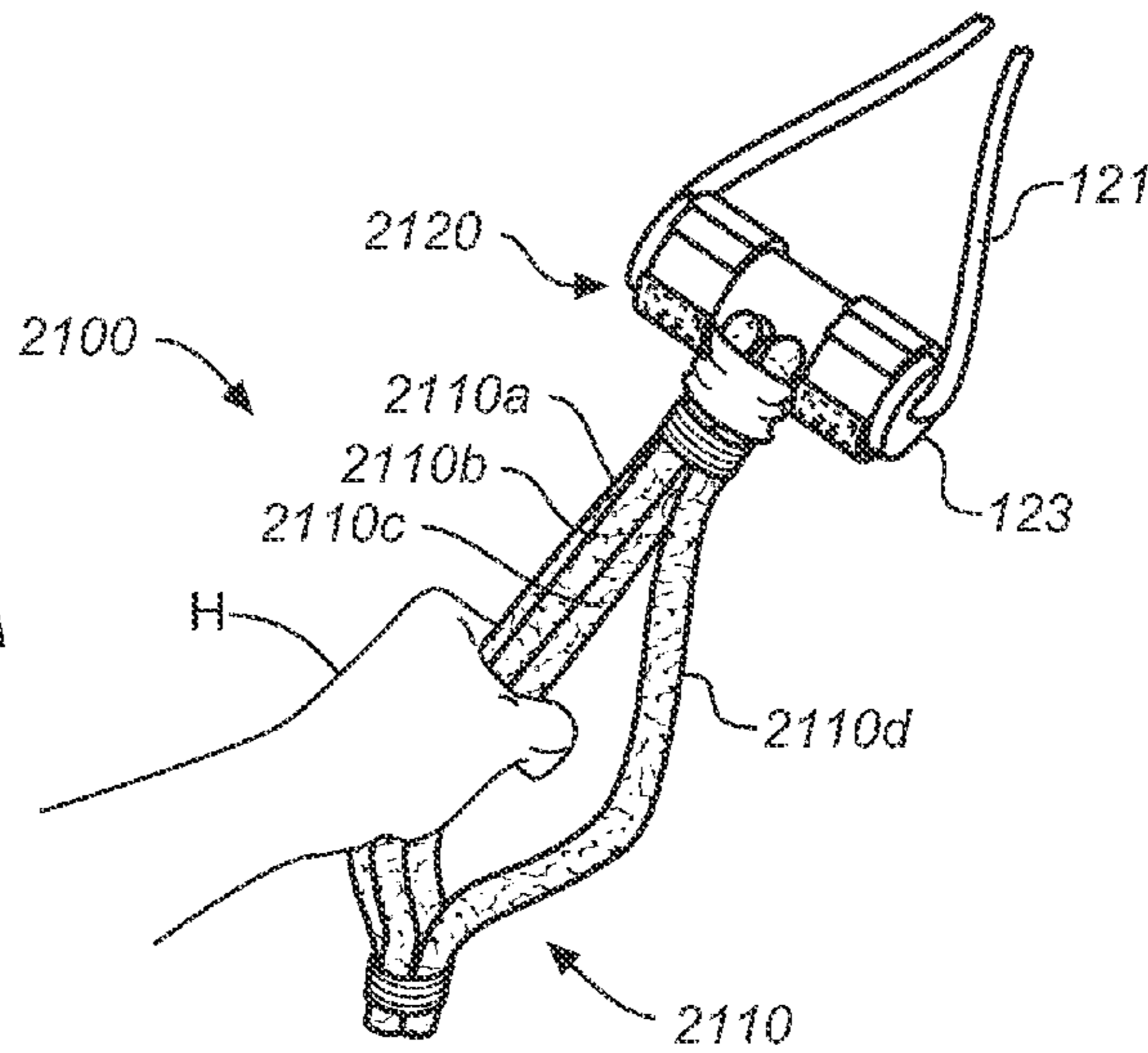

FIG. 21B

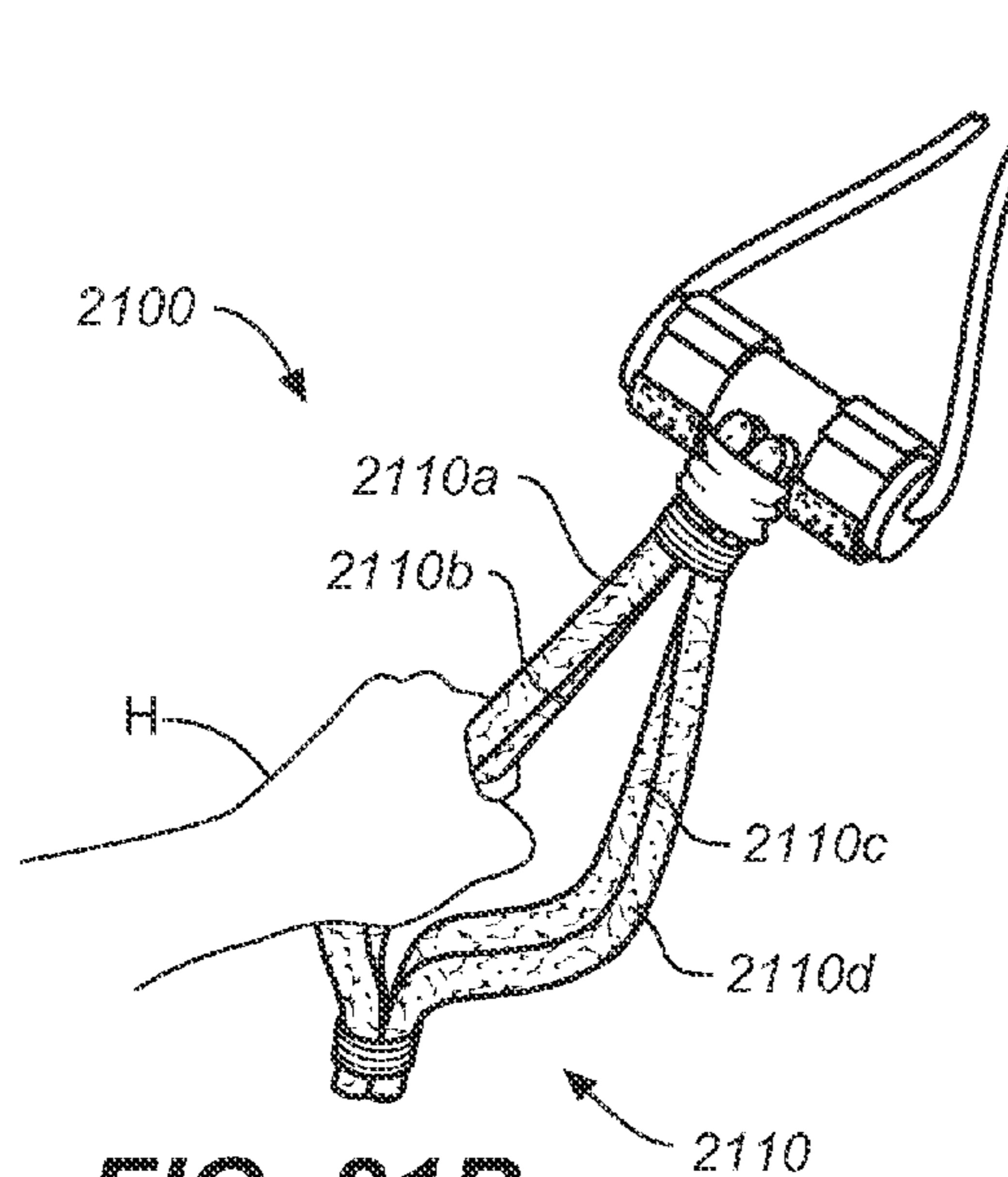
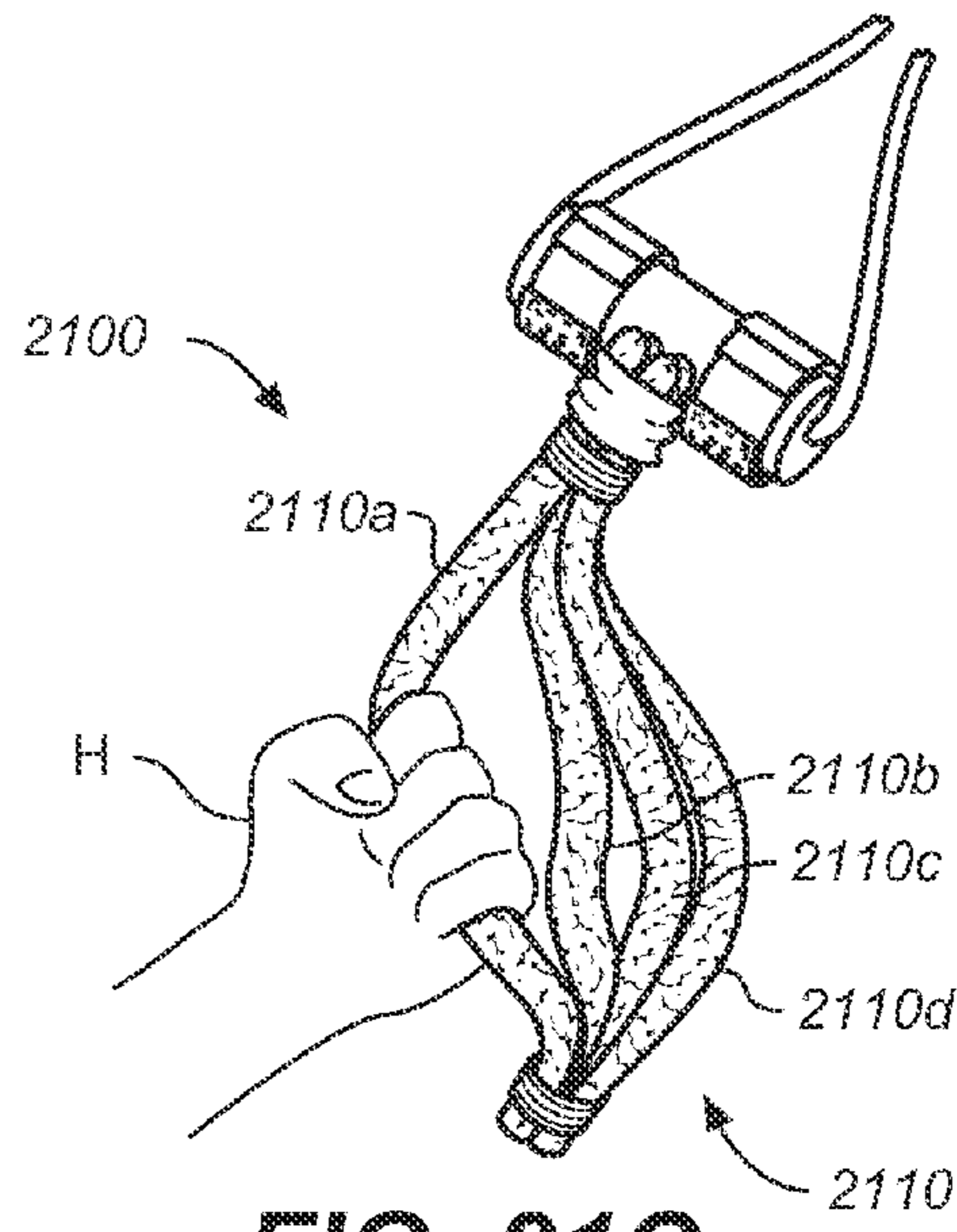
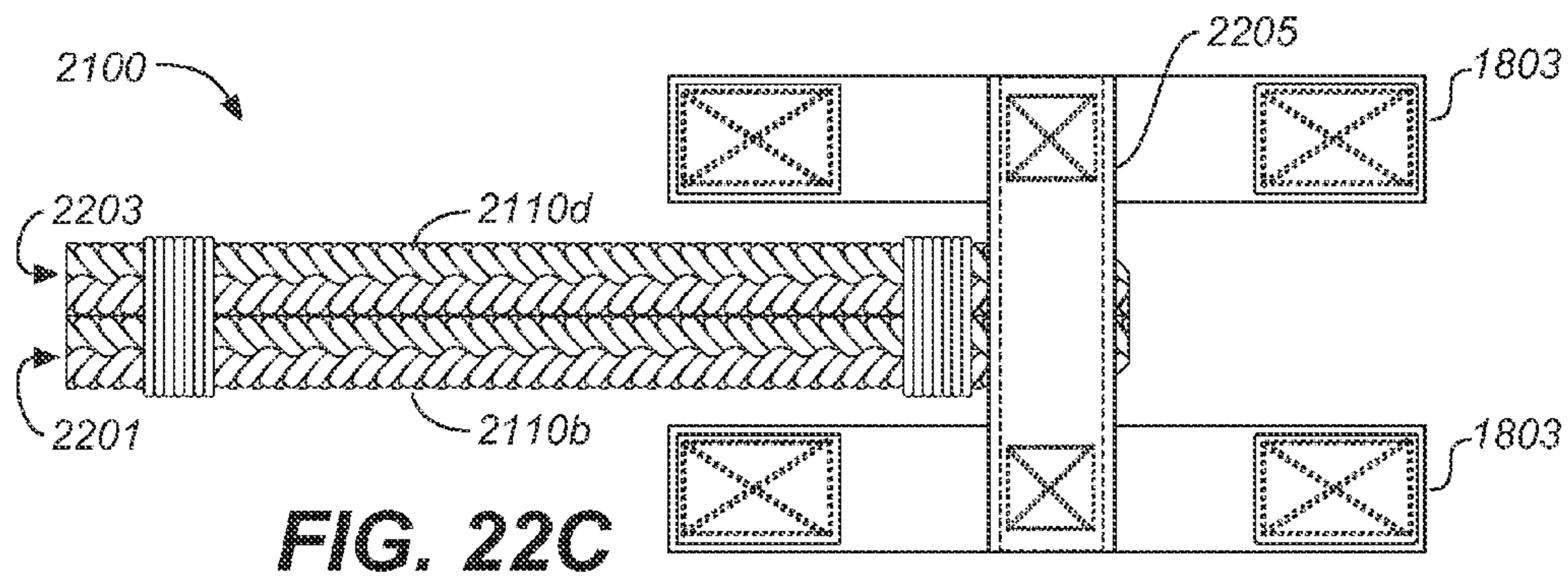
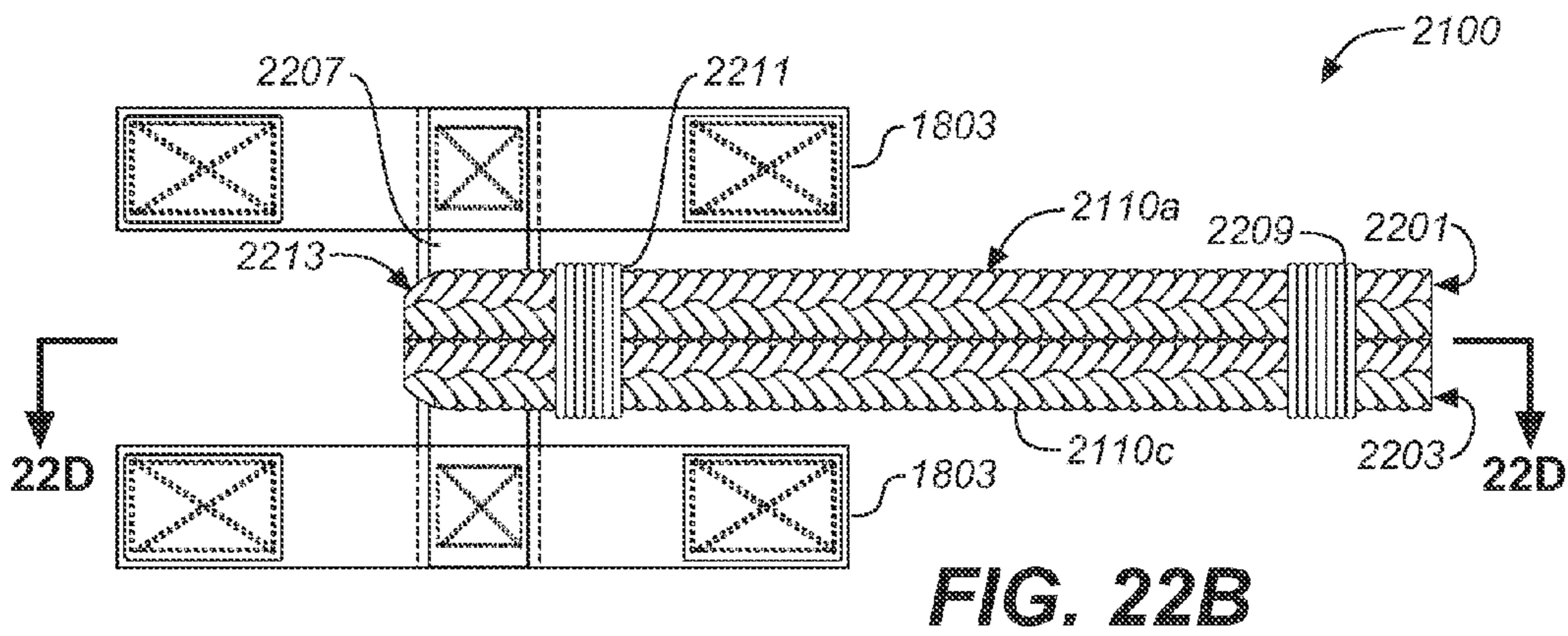
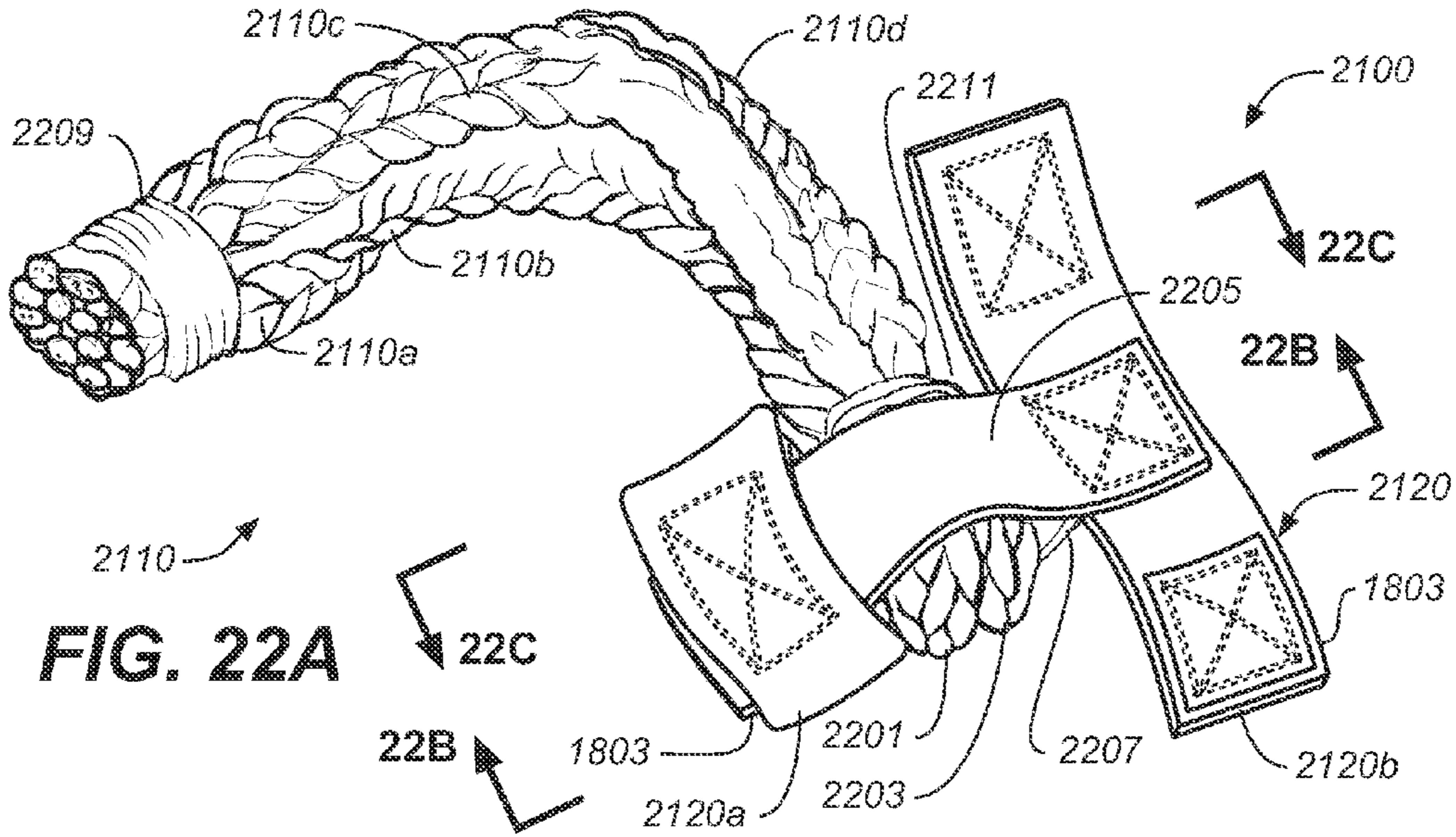

FIG. 21C





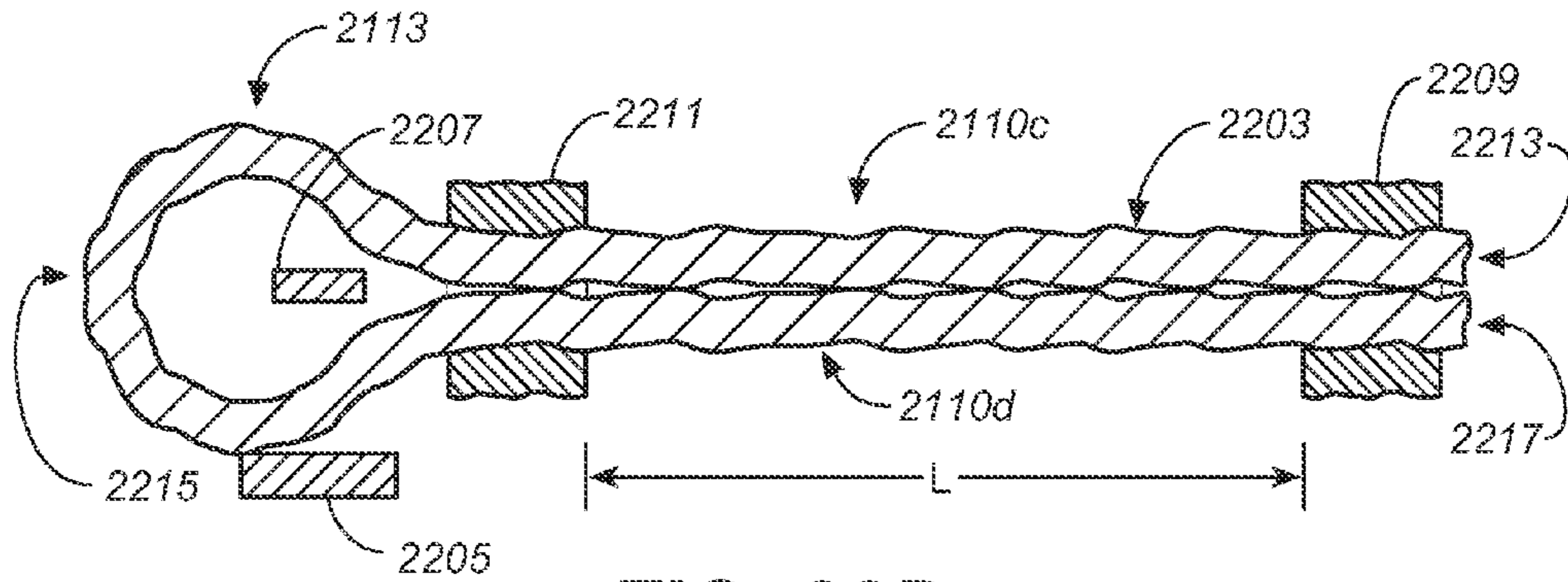

FIG. 22D

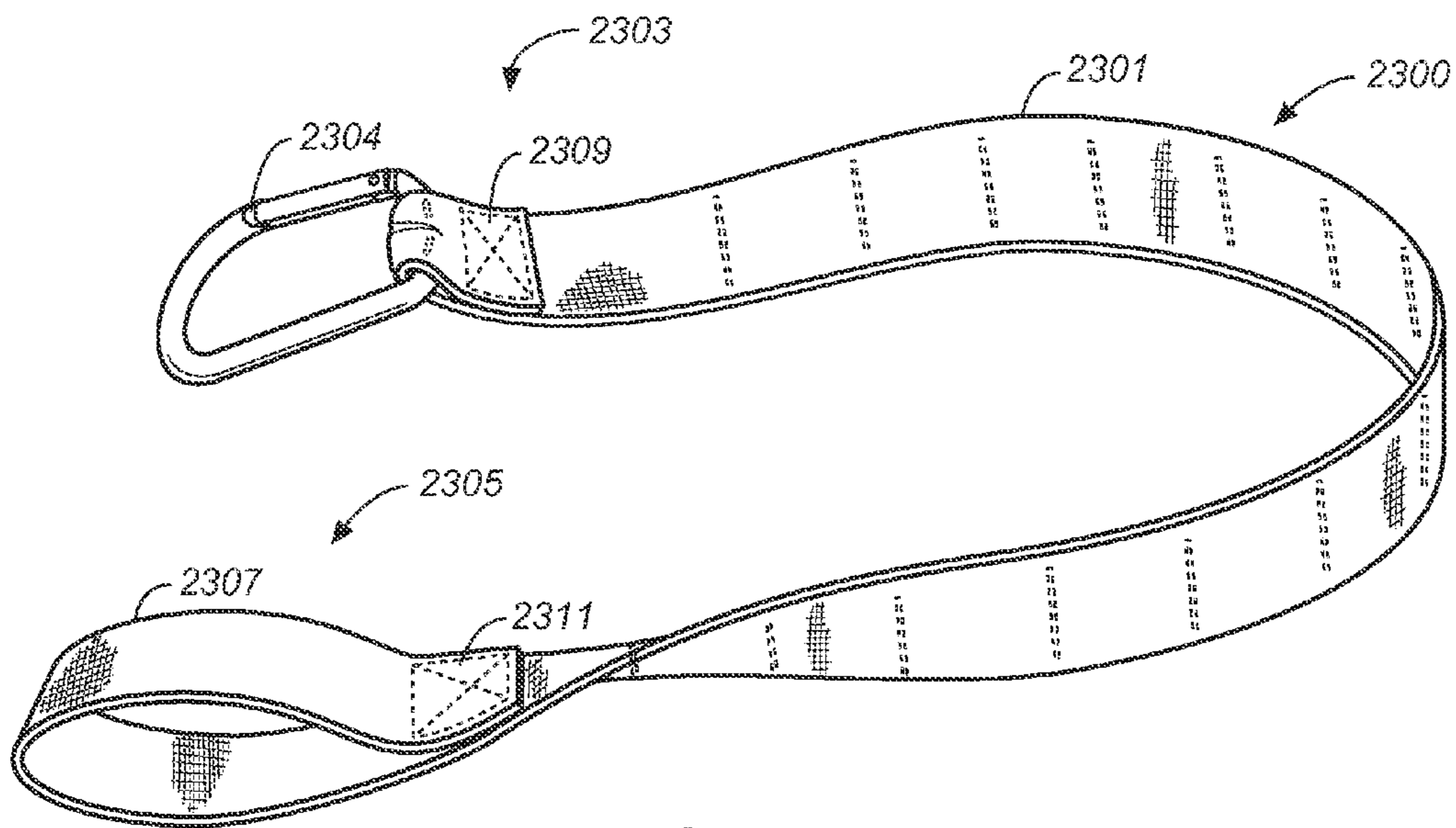

FIG. 23

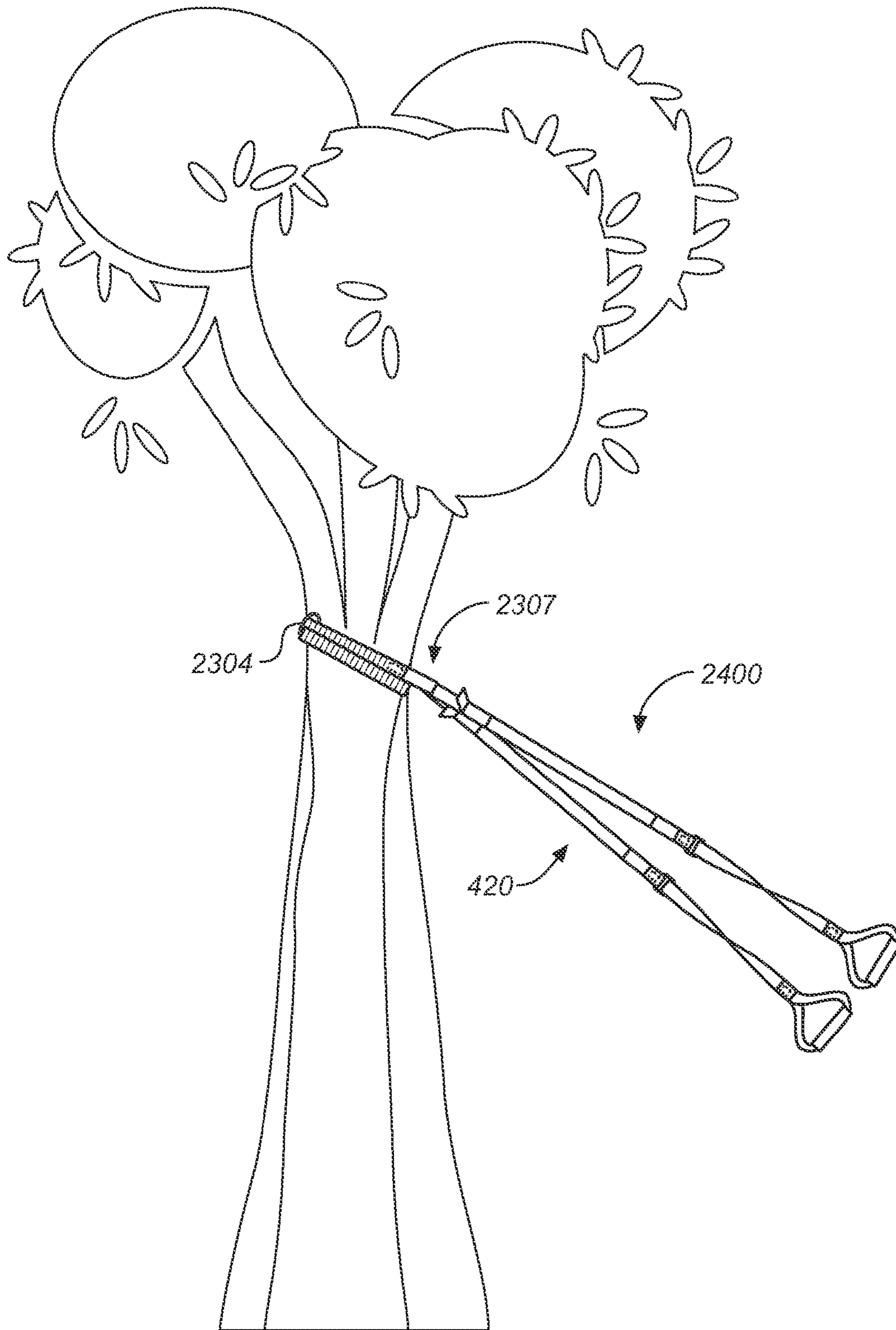

FIG. 24

FIG. 25

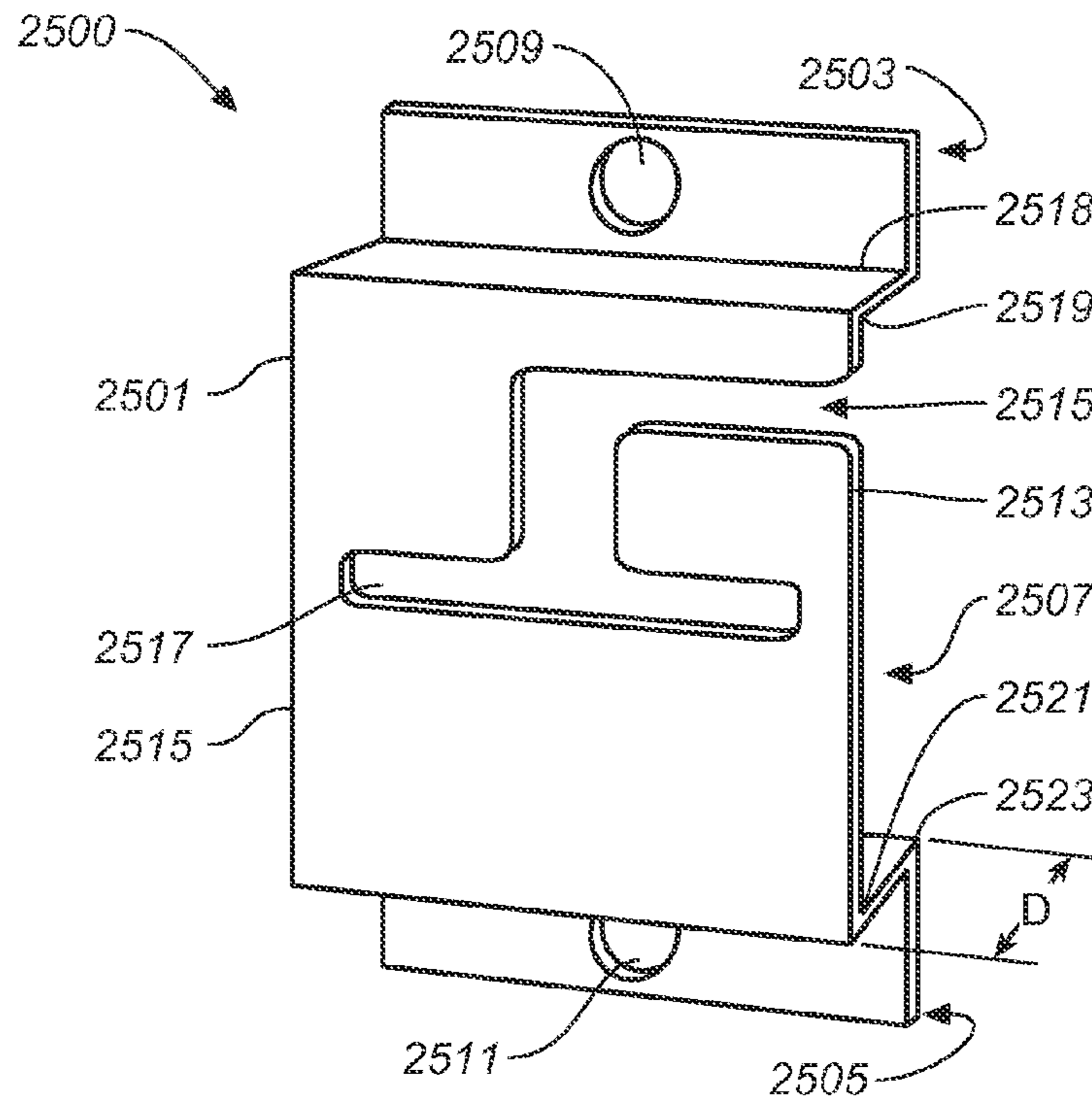
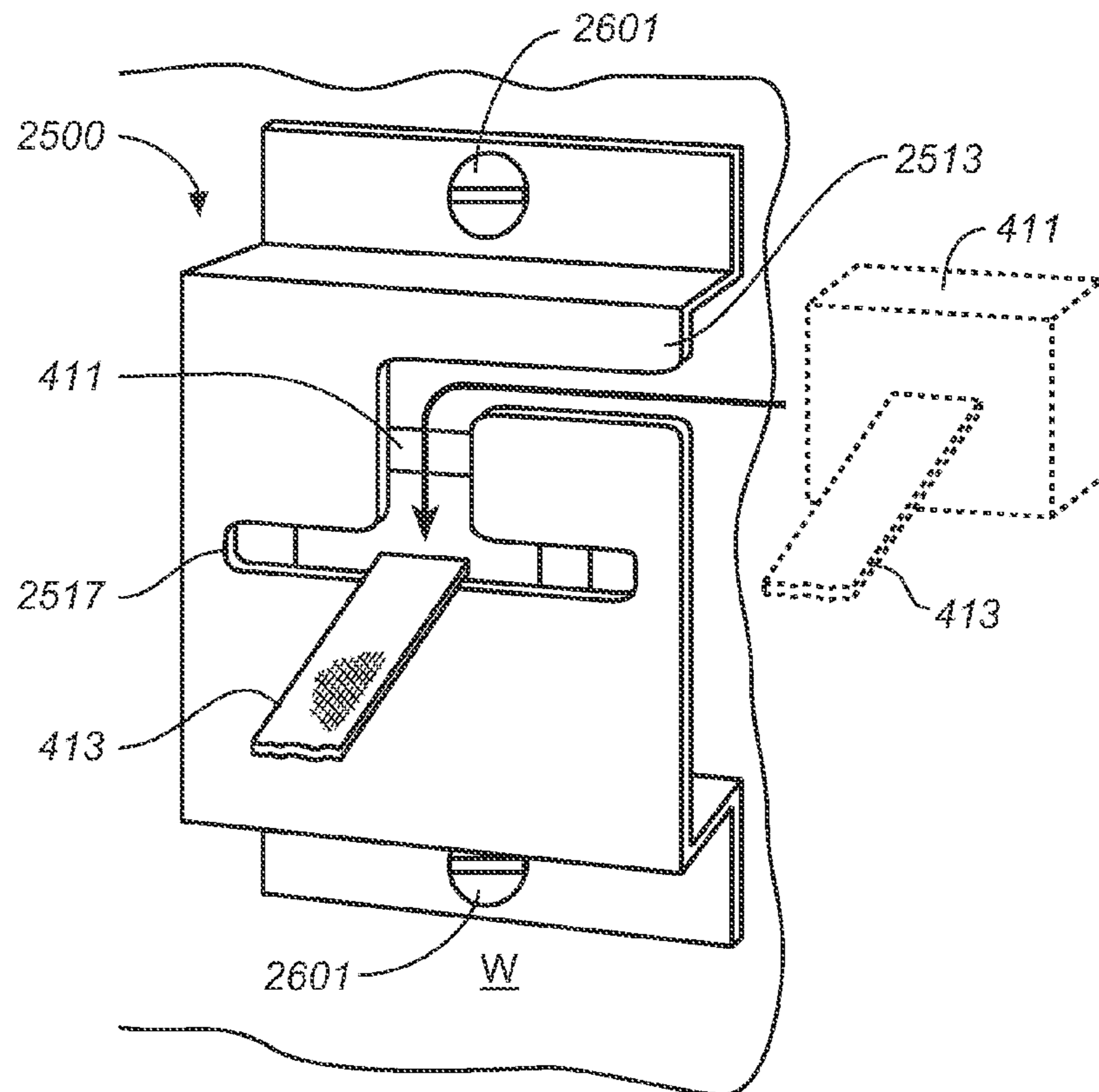

FIG. 26



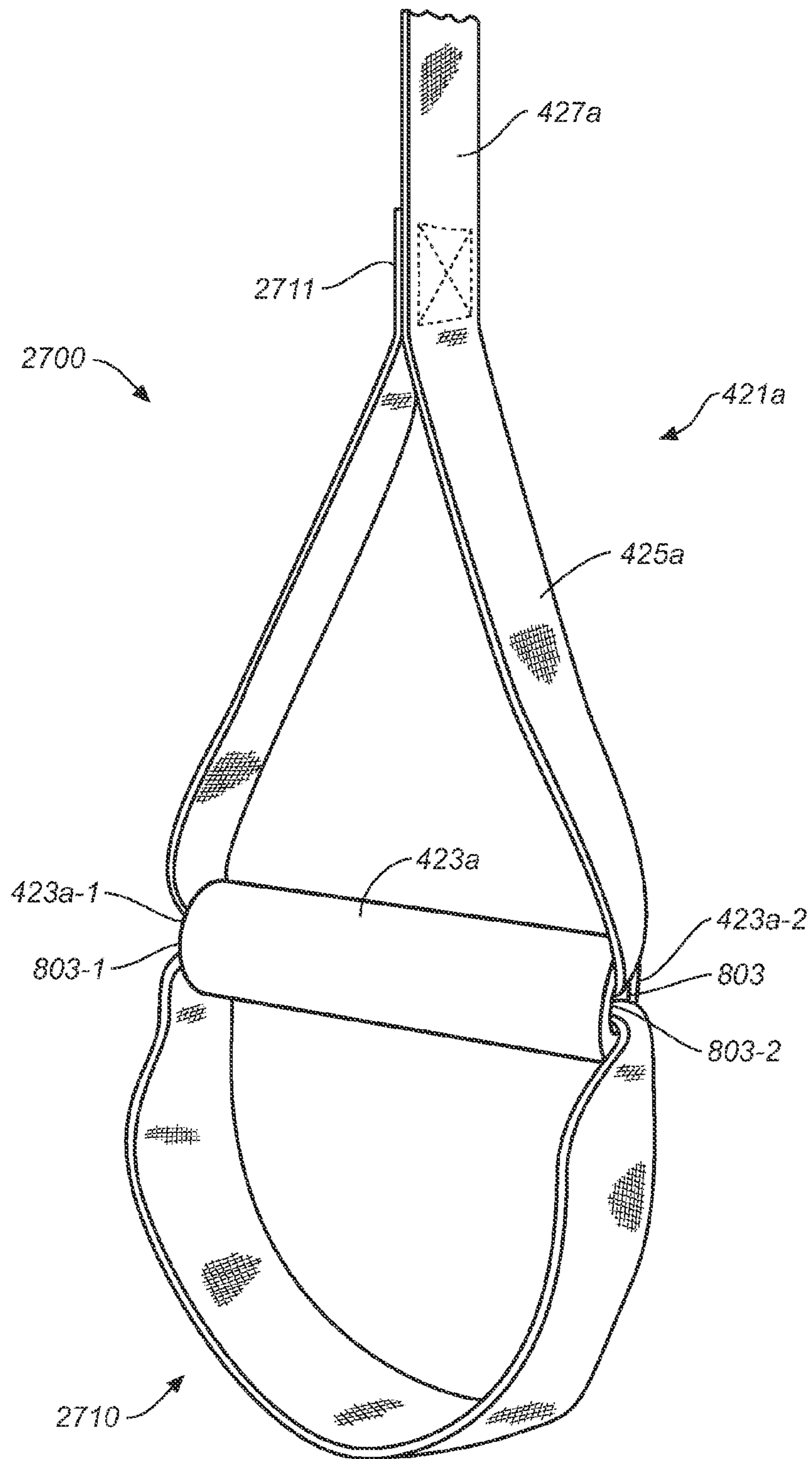

FIG. 27

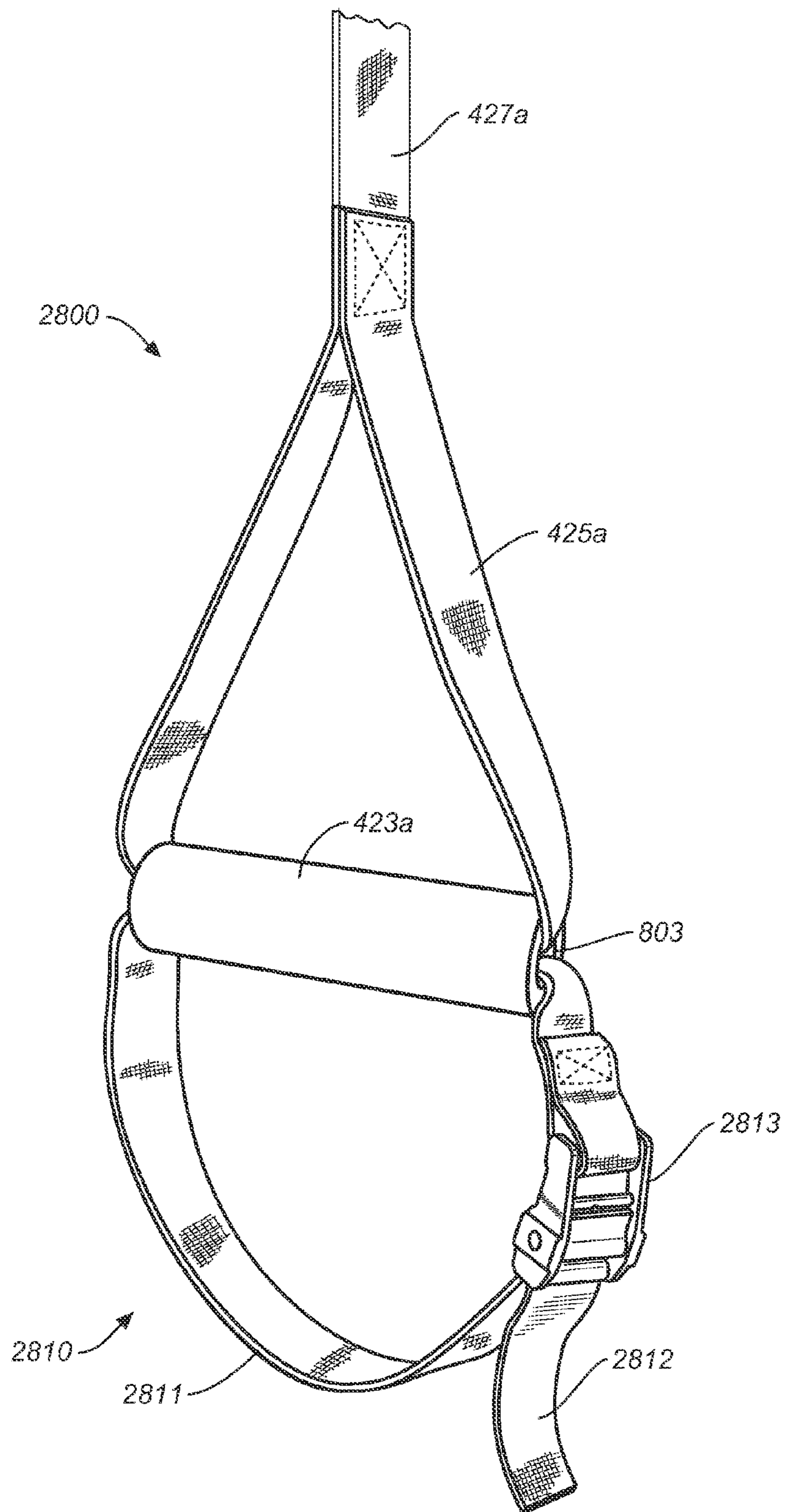

FIG. 28

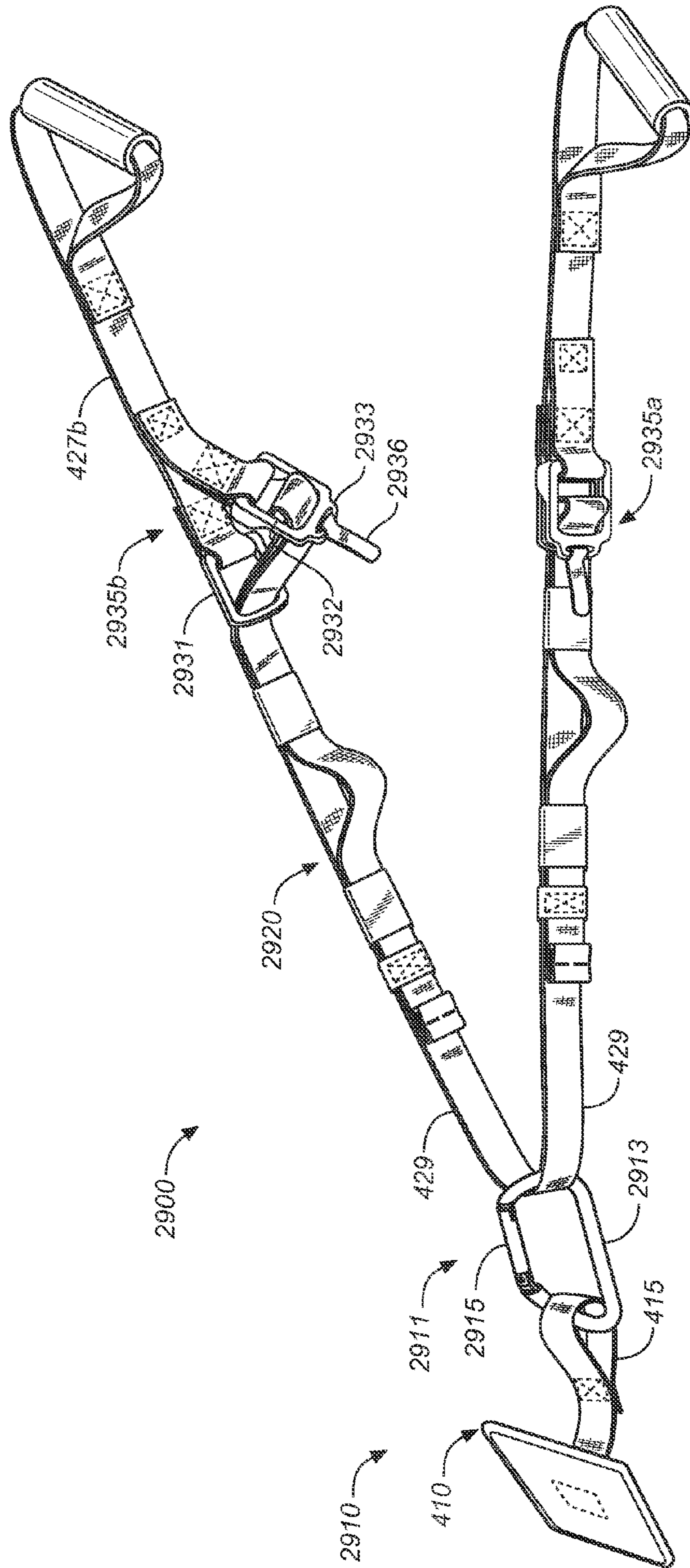

FIG. 29

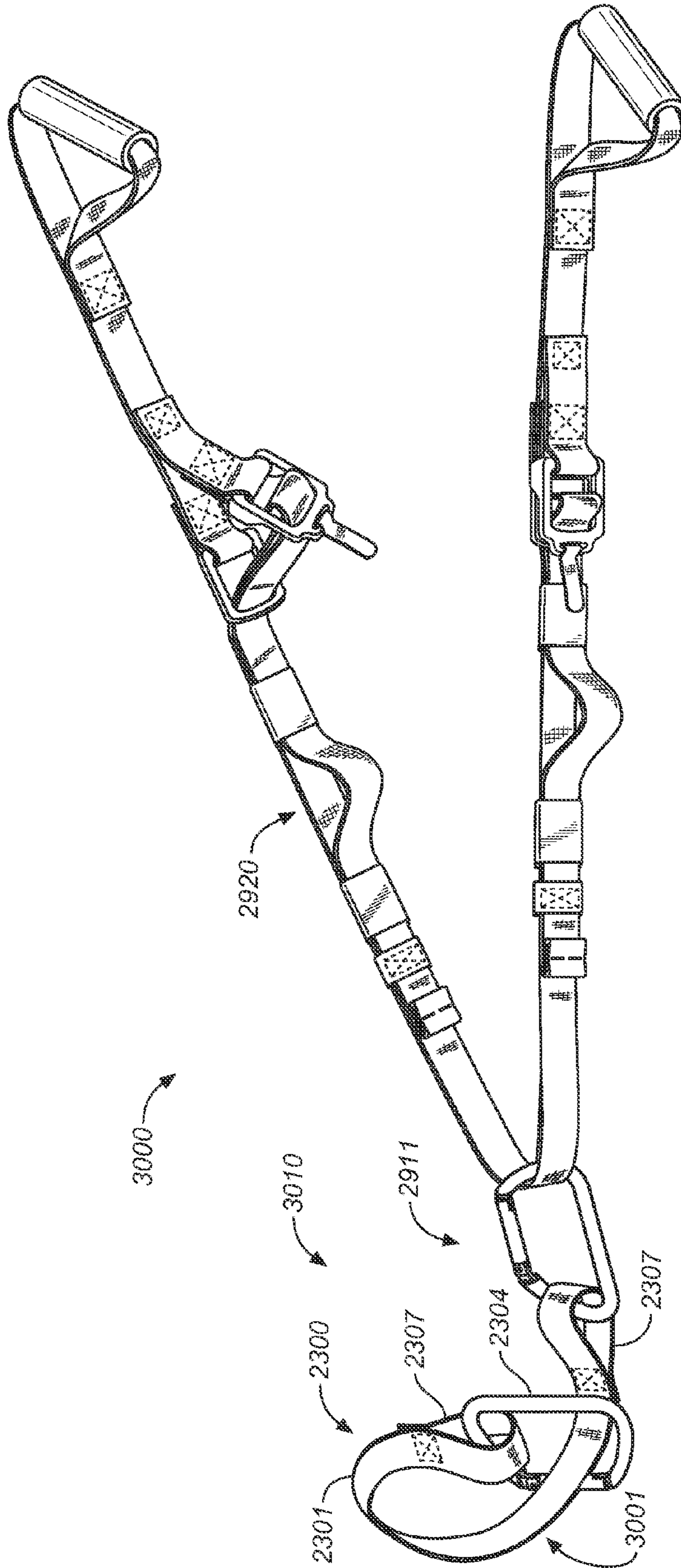

FIG. 30

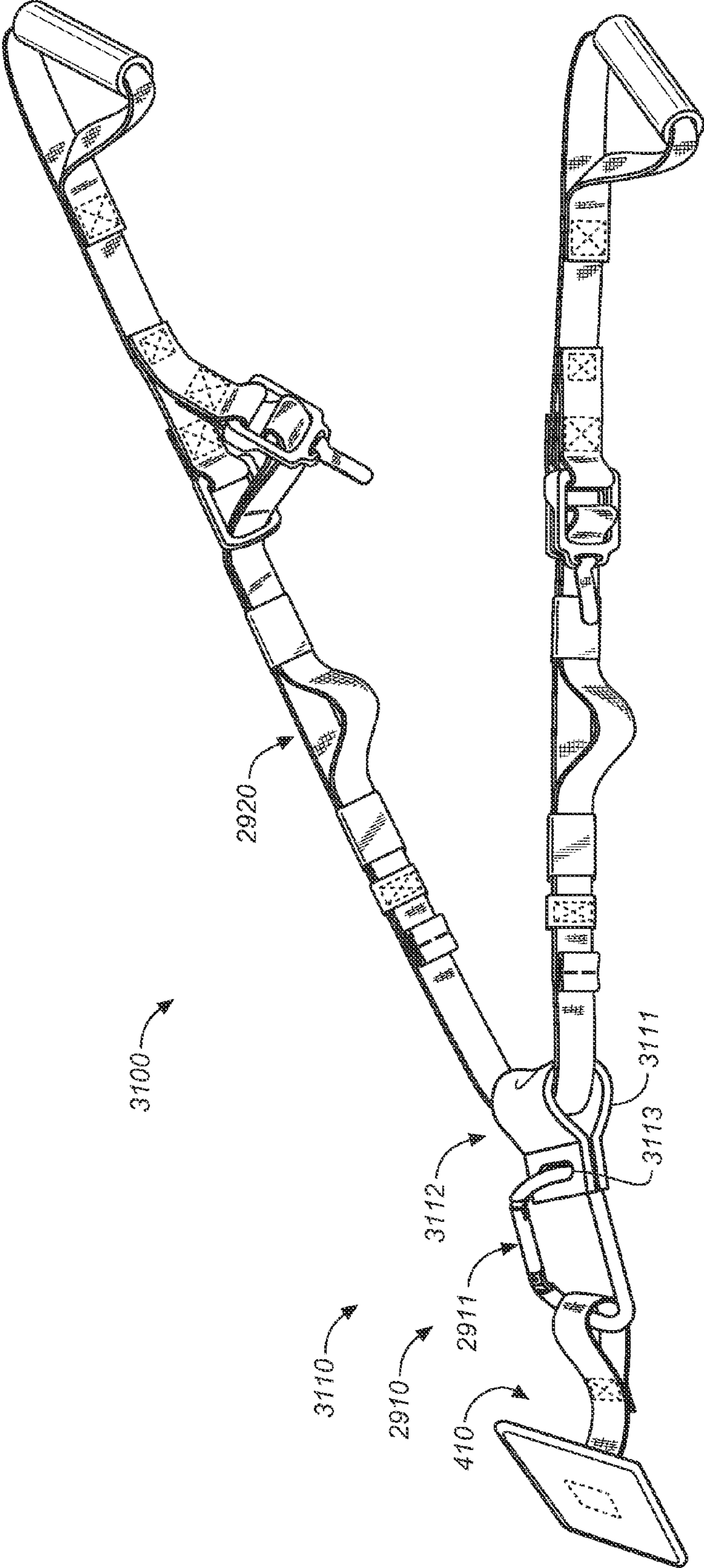

FIG. 31

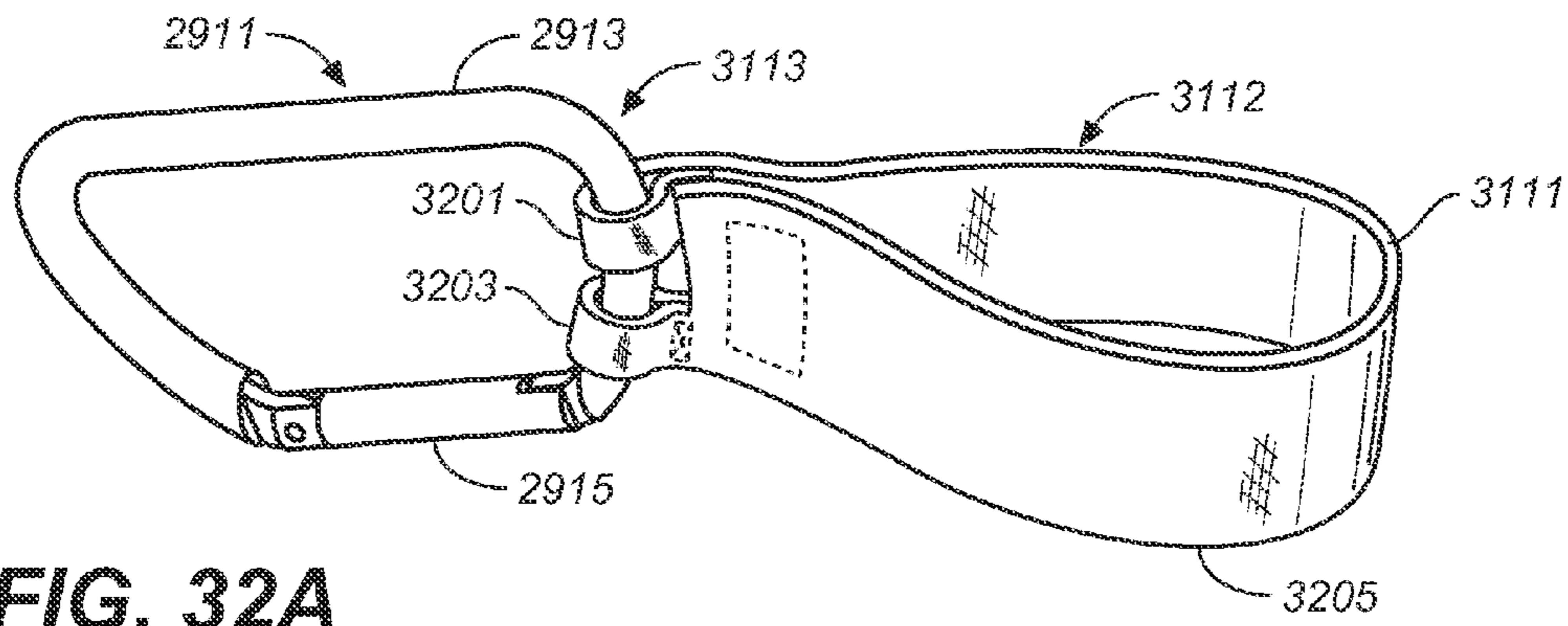

FIG. 32A

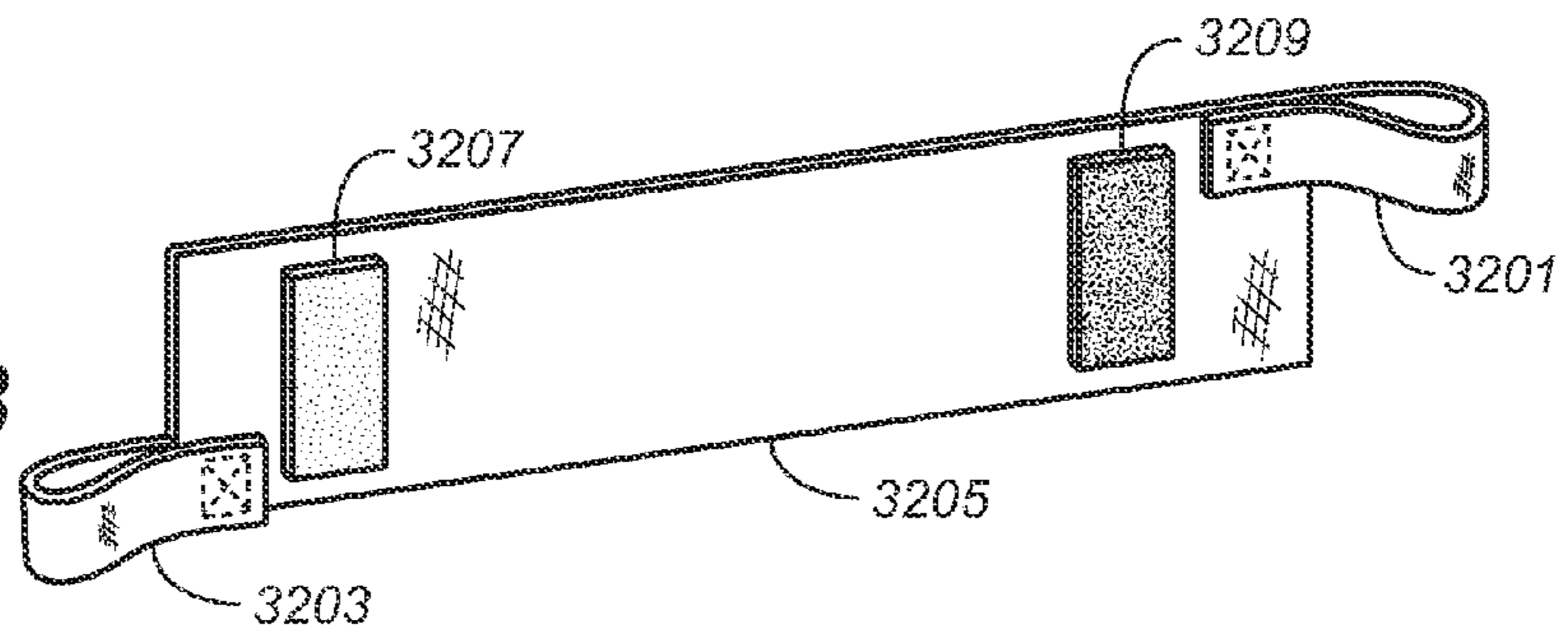

FIG. 32B

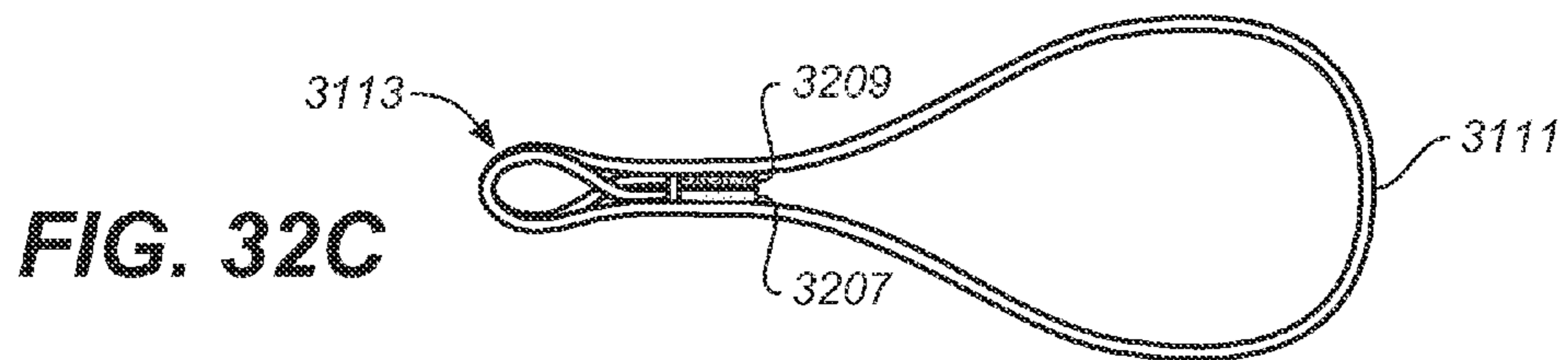

FIG. 32C

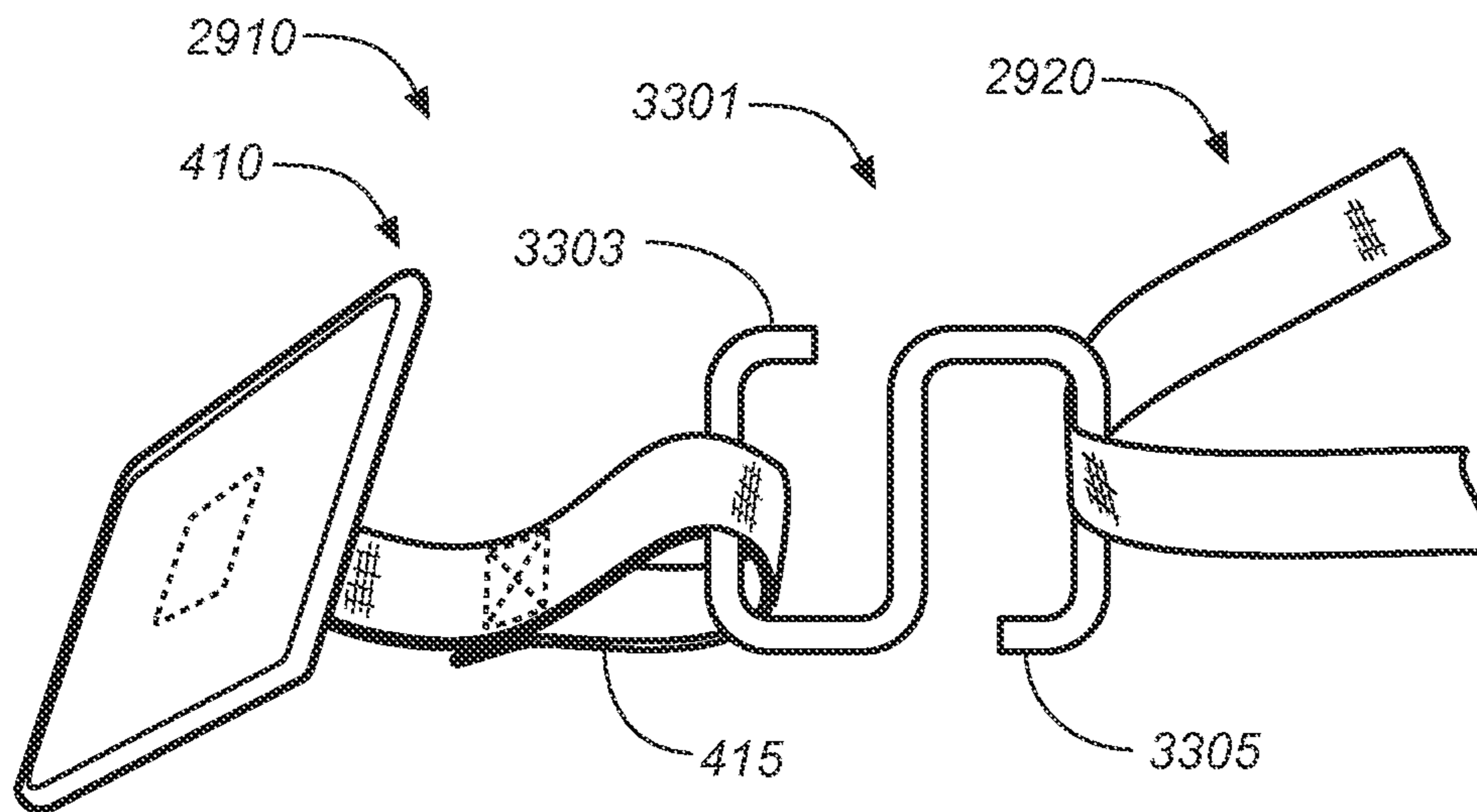

FIG. 33

EXERCISE DEVICE HAVING INELASTIC STRAPS AND INTERCHANGEABLE PARTS

CROSS-REFERENCE TO RELATED APPLICATIONS

This application is a continuation of U.S. patent application Ser. No. 11/948,875, filed Nov. 30, 2007, now U.S. Pat. No. 8,043,197 which claims the benefit of U.S. Provisional Application No. 60/973,129 filed Sep. 17, 2007, the entire contents of which are hereby incorporated by reference herein and made part of this specification.

BACKGROUND OF THE INVENTION

The present invention generally relates to exercise devices, and in particular to an exercise device having an anchor that formed from components that can be removed, replaced, and/or interchanged.

Resistance exercise devices allow a user to exercise by providing a resistance to the movement of a user's arms, legs, or torso. Thus, for example, such devices allow a user to exercise by working one muscle against another, or by working against the weight of the user, by providing a resistance to the movement of a user's arms, legs, or torso. Resistance exercise devices typically include either elastic bands or inelastic straps.

Resistance exercise devices having inelastic straps are typically attachable to a structure, such as, for example, a door. In general, the anchors for such devices are not very flexible in that they are attachable to one type of structure and/or are permanently attached to the exercise device.

There is a need to provide an anchor for an exercise device that is capable of being attached to a variety of structures. There is also a need to provide an anchor for an exercise device that is easily adaptable for attaching to a variety of structures. There is a further need to provide an anchor for an exercise device having easily replaceable components.

BRIEF SUMMARY OF THE INVENTION

The present invention overcomes the disadvantages of prior art by providing an exercise device that is easily configurable and mountable to a variety of structures. For example, certain embodiments described herein include a number of interlocking components that support an exercise device to a structure. In certain other embodiments, the anchor components include one or more of a rigid ring or a flexible ring, which may be open or openable.

In certain embodiments, an anchor to attach an exercise device to a structure is provided, where the exercise device includes an elongated inelastic member having grips. The anchor includes a first portion attachable to the structure, and a second portion including a frictional support for the elongated inelastic member. When the first portion attached to the structure, the second portion is removably connectable to the first portion.

In certain other embodiments, an anchor attachable to an exercise device and a structure is provided, where the exercise device includes an elongated inelastic member having grips. The anchor includes a first portion attachable to the structure and a second portion including a frictional support for the elongated inelastic member. The anchor also includes means for removably connecting the first portion and the second portion with the second portion attached to the structure.

In certain embodiments, an anchor to support an exercise device to a structure is provided, where the exercise device

includes an elongated inelastic member having grips. The anchor includes a first loop including a length of flexible material adapted to receive the elongated inelastic member; and a second loop removably attachable to the first loop.

These features together with the various ancillary provisions and features which will become apparent to those skilled in the art from the following detailed description, are attained by the exercise device of the present invention, embodiments thereof being shown with reference to the accompanying drawings, by way of example only, wherein:

BRIEF DESCRIPTION OF THE SEVERAL VIEWS OF THE DRAWING

FIG. 1 is a schematic front view of a first embodiment of an exercise device as anchored between a door and door jamb;

FIG. 2 is a partial schematic sectional view 2-2 of FIG. 1 showing the exercise device anchored between a door and door jamb;

FIG. 3 is illustrative of a user performing a high row exercise with the exercise embodiment of FIG. 1;

FIG. 4 is a perspective view of a second embodiment of an exercise device;

FIGS. 5A and 5B are views of a first embodiment of an anchor of the exercise device of FIG. 4, where FIG. 5A is a perspective view, and FIG. 5B is sectional view 5B-5B;

FIG. 6 is a schematic top view of the elongated member of the embodiment shown in FIG. 4 having two lengthening mechanisms and two hand grips;

FIG. 7 is a perspective view showing details of the grip and the lengthening mechanism of the embodiment of FIG. 4;

FIG. 8 is a sectional view 8-8 of FIG. 7 showing the hand grip;

FIG. 9A is a perspective view showing details of the slack sleeves of the embodiment of FIG. 4;

FIG. 9B is a sectional view 9B-9B of FIG. 9A showing details of the buckle and attachment of the slack sleeves to the buckle;

FIG. 10 is a schematic top view of an alternative elongated member embodiment having one lengthening mechanism and two finger grips;

FIG. 11 is schematic sectional view 11-11 of the finger grip embodiment of FIG. 10;

FIGS. 12A-12D are schematic drawings illustrating the use of the exercise device, where FIG. 12A is the initial configuration, FIG. 12B illustrates lengthening the elongated member, further illustrated in FIGS. 12B' and 12B'', FIG. 12C shows the application of force to the shorter leg of the elongated member, and FIG. 12D shows the application of force to the grips during an exercise;

FIGS. 13A-13C are schematic drawings illustrating the use of the exercise device having differing arm lengths, where FIG. 13A is the initial configuration, FIG. 13B shows the application of force to one of the pair of legs, and FIG. 13C shows the application of force to the grips during an exercise;

FIG. 14A is a second embodiment of an anchor that can be used for attaching the exercise device to a pole or railing, and FIG. 14B is a exercise device anchored to a pole using the alternative anchoring embodiment of FIG. 14A;

FIGS. 15A-15I illustrate poses of a user using an embodiment of an exercise device to perform exercises, where FIG. 15A is a reverse combination crunch, FIG. 15B is a single leg L-squat, FIG. 15C is a gymnast dip, FIG. 15D is a kneeling combination crunch, FIG. 15E is a lying leg curl, FIG. 15F is a hip lift, FIG. 15G is a front shoulder raise, FIG. 15H is a crunch, and FIG. 15I is a triceps extension;

FIGS. 16A and 16B illustrate an embodiment of the exercise device for doing one handed exercises, where FIG. 16A shows interlocking the handles for one handed exercises, and FIG. 16B illustrates the use of the exercise device in performing a one arm high row exercise;

FIGS. 17A and 17B show an embodiment of a foot grip accessory as attached to a grip of an exercise device, where FIG. 17A illustrates the foot grip accessory gripped by the user's toes, and FIG. 17B illustrates a pair of foot grip accessories with one accessory on each of the pair of grips of an exercise device and grasped by one of the user's heels;

FIGS. 18A, 18B, 18C and 18D show a first embodiment of the foot grip accessory of FIGS. 17A-B, where FIG. 18A is a perspective view of the foot grip accessory, FIG. 18B is a bottom view of the foot grip accessory, FIG. 18C is a side view of part of one of the grip attachment portions, and FIG. 18D is a top view of part of one of the grip accessory attachment portions;

FIGS. 19A, 19B, and 19C show an embodiment of a finger grip accessory as attached to a grip of an exercise device, where FIG. 19A illustrates the one finger placed through one of the loops, FIG. 19B illustrates one finger be placed through each of the two loops, and FIG. 19C shows two fingers placed through each of the two loops;

FIGS. 20A, 20B, and 20C show one embodiment of the finger grip accessory of FIGS. 19A-C, where FIG. 20A is a perspective view of the finger grip accessory, FIG. 20B is a top view 20B-20B of the finger grip accessory, and FIG. 20C is a sectional side view 20C-20C of the finger grip accessory;

FIGS. 21A, 21B, and 21C shown an embodiment of a grip accessory as attached to a grip of an exercise device, where FIG. 21A illustrates a hand gripping three cords, FIG. 21B illustrates the hand gripping two cords, and FIG. 21C illustrates the hand gripping one cord;

FIGS. 22A, 22B, 22C, and 22D show one embodiment of the grip accessory of FIGS. 21A-C, where FIG. 22A is a perspective view of the grip accessory, FIG. 22B is a top view of the grip accessory, FIG. 22C is a bottom view of the grip accessory, and FIG. 22D is sectional side view 22D-22D of FIG. 22C;

FIG. 23 shows a third embodiment of an anchor;

FIG. 24 illustrates the use of the anchor of FIG. 23 to anchor an exercise device to a tree;

FIGS. 25 and 26 shows an embodiment of a bracket for securing an exercise device by an enlarged first end of an anchor, where FIG. 25 is a perspective front view of a bracket for mounting an exercise device, and FIG. 26 illustrates the use of the bracket to anchor the exercise device;

FIG. 27 is a perspective view of a first embodiment combination grip;

FIG. 28 is a perspective view of a second embodiment combination grip;

FIG. 29 is a perspective view of an exercise device including a fourth embodiment of an anchor and a second embodiment of an elongated member;

FIG. 30 is a perspective view of an exercise device including a fifth embodiment of an anchor;

FIG. 31 is a perspective view of an exercise device including a sixth embodiment of an anchor;

FIGS. 32A-32C are views of one embodiment of a support for the exercise device of FIG. 31, where FIG. 32A, is a perspective view showing the support connected to a ring, FIG. 32B is perspective view of the support unfolded, and FIG. 32C is an end view of the support ready to accept a ring; and

FIG. 33 is a perspective view of a seventh embodiment of an anchor.

Reference symbols are used in the Figures to indicate certain components, aspects or features shown therein, with reference symbols common to more than one Figure indicating like components, aspects or features shown therein.

DETAILED DESCRIPTION

For purposes of contrasting various embodiments with the prior art, certain aspects and advantages of these embodiments are described where appropriate herein. Of course, it is to be understood that not necessarily all such aspects or advantages may be achieved in accordance with any particular embodiment. Modifications and variations can be made by one skilled in the art without departing from the spirit and scope of the invention including, but not limited to: the use of inelastic members, which are described herein as straps, that are round or have some other cross-sectional shape, and/or which are formed from two or more members joined together, as by stitching or with an adhesive; or the use of different mechanisms for adjusting the length of inelastic member that are known in the field including, but not limited to, buckles, hooks, or winding the inelastic member about a rigid element. Moreover, any one or more features of any embodiment may be combined with any one or more other features of any other embodiment, without departing from the scope of the invention.

Disclosed herein is an inelastic exercise device that is supported by, or that can be easily attached to, a supporting structure, and that allows a user to perform a large number of exercises by easily adjusting the length of the device and thereafter balancing the device as the user's weight is transferred to the device. Several of the features will now be illustrated with reference to FIGS. 1-3. FIG. 1 is a schematic front view of a first embodiment of exercise device 100 that is anchored at a point A between a door D and door jamb J. FIG. 2 is a partial sectional view 2-2 of FIG. 1 taken through door D and showing exercise device 100 in profile, and FIG. 3 is illustrative of a user U exercising with the exercise device of FIG. 1.

Exercise device 100 includes an anchor 110 and an elongated member 120 having a pair of arms 122, indicated as a first arm 122a and a second arm 122b, on either side of the anchor, as shown schematically in FIGS. 1 and 2. A pair of grips 123 is provided, with one positioned at each end 121 of each arm 122, specifically first arm 122a has a first grip 123a, and second arm 122b has a second grip 123b. Elongated member 120 is substantially inelastic and flexible with a length S between the pair of grips 123, and includes a strap or cord or other inelastic, flexible member, and a lengthening mechanism 135 that provides for increasing or decreasing the length S, as indicated by double arrows AS.

As used herein, the noun "grip" encompasses any device that is interlockable with part of the human body, that is it can be connected in such a way that a person can transfer a force to the grip, preferably a force equal to some or all of the person's weight, and the verb "grip," when used herein, refers to the action of interlocking the device and a body part. When used in an exercise device, a grip is attached to other elements that permit the force to be transferred to another object, including but not limited to a stationary support, a device that can store or release energy, such as an elastic cord or a spring, or another body part. Grips include devices that can be surrounded by a body part, for example flexible loop or a hook, or that a body part can surround, for example an elongated member that can fit within the grasp of the hand. In this context, a member that can be gripped, or is grippable, is one that can surround a body part or can be surrounded by a body

part, and has a size and configuration that permits the transfer of forces from the user to the grip. A “hand grip” is grip that is sized for grasping by the hand, a “foot grip” is grip that is sized for grasping a foot, and a “finger grip” is grip that is sized for grasping by one or more fingers.

Anchor **110** provides a support for elongated member **120** that permits some amount of movement. Specifically, the interaction of anchor **110** and elongated member **120** allows the elongated member to be positioned along on the anchor, and may also provide resistance to the movement of the elongated member along the anchor. Preferably the resistance is sufficient so that, under some circumstances, the support prevents movement of elongated member **120** along anchor **110**, even where there is some mis-match of forces on the ends of the elongated member. In this way exercise device **100** may be used for a variety of exercises, by changing the length of elongated member **120**, for example, and also provide an exercise device that can provide support for the user while exercising.

One type of support is referred to herein, without limitation, as a “frictional support.” Anchors that provide frictional support include, but are not limited to, an element or portion of an element that can support elongated member **120** during exercising, and over which the elongated member can slide. Resistance to the movement of elongated member **120** over anchor **110** may be determined, in part, by the frictional resistance of the elongated member sliding over the anchor. In several embodiments of methods of using exercise device **100**, elongated member **120** slides along anchor **110** while a user positions herself. During exercising, a slight mis-match in the pulling forces on the grips is matched by static friction of the frictional support, and the grips do not move while exercising. That is, the static friction between elongated member **120** and anchor **110** generated by the frictional support is sufficient to permit exercises in which elongated member **120** does not slide through anchor **110** while exercising. Means that provide frictional support include elements or portions of elements that form part of or which are attached to an anchor and which can support an elongated member (that may, for example, include grips) and which can allow the elongated member to slide along the supporting anchor and provide frictional resistance to the motion of the elongated member during exercising.

Anchor **110** is used to provide a fixed anchor point for exercise device **100** and to support a user’s weight as it is applied to arms **122** as indicated by an arrow F in FIG. 2 and as shown in FIG. 3. As shown in FIG. 2, anchor **110** is adapted for positioning exercise device **100** in a door and providing support to elongated member **120** by having an enlarged portion **111**, a portion **113** that can be strap or cord, and an approximately triangular shaped loop **115** that is a frictional support for of the elongated member. With enlarged portion **111** on the opposite side of door D from elongated member **120**, anchor **110** supports the weight of a user as grips **123** are pulled. In addition, anchor **110** provides for positioning the relative length of arms **122** as shown in FIG. 1 by double arrow C. Thus, the total length of elongated member **120** and distribution of that length between each of arms **122** can be easily adjusted through the lengthening mechanism **135** and by pulling the ends of the elongated member. FIG. 2 shows arms **122** each having a length L.

When supported by a structure, such as door D (as shown, for example, in FIGS. 1-3) or a railing, pole or other support member (as shown, for example, in FIGS. 14B and 26) the inventive exercise device provides a pair of grips for a user to exercise against her weight according the user’s position relative to the device, and provides for easily adjusting the length

of the device. As described below, the inventive device can be used to exercise in any one of a large number of orientations according the selected adjustable length and according to where and how the user stands relative to the exercise device.

In general, a user sets the exercise device to a desired length, positions herself on the ground near the exercise device, supports a portion of her body weight from the exercise device by her hands or feet, and exercises by moving her body with her weight supported by the ground and the exercise device. Examples of support on the ground and exercise device include, but are not limited to, standing on one or both legs, lying on the stomach or the back, kneeling, or by having the hands on the ground, and having the exercise device support ones weight by the hands or feet, as appropriate.

In an alternative embodiment (not shown), elongated member **120** does not include a lengthening mechanism **135**. In this embodiment, elongated member **120** is thus substantially inelastic and has a fixed length S between the pair of grips **123**.

With reference to FIG. 3, a user U is shown in one of the many exercise positions, in particular a high row exercise, gripping the pair of grips **123** with the user’s hands and having the user’s feet placed a horizontal distance X from anchor point A. When anchored to a door, it is preferred that anchor point A is on the inwards side of the door (that is, that the door open away from user U) so that jamb J can support the user’s weight. The user U is shown leaning away from anchor point A and supporting a fraction of his or her weight through device **100**. It is apparent that user U can vary the amount of supported weight, and thus the resistance of exercise device **100**, by adjustment of his or her stance relative to anchor point A (distance X) and the length of arms **122** (length L). The user U of FIG. 3 performs a high row exercise by moving his body in a direction E towards and away from anchor point A. Note that other exercises are also possible with the user in this position by the user moving in other directions with the user’s weight supported by the ground and exercise device **100**.

Several embodiments will now be described with reference to the drawings. These embodiments are meant to be illustrative and not limiting to the scope of the claims. FIGS. 4-9 are various views of a second embodiment of an exercise device **400**. Referring first to FIG. 4, a perspective view of exercise device **400** is shown as including a first embodiment of an anchor **410** and an elongated member **420**. Exercise device **400**, anchor **410**, and elongated member **420** are generally similar to exercise device **100**, anchor **110**, and elongated member **120**, respectively, except further detailed below. Where possible, similar elements are identified with identical reference numerals in FIGS. 1-9.

Anchor **410** includes an inelastic, flexible strap **413** having an enlarged first end **411** that is wider than the strap, and a second end that forms a loop **415**. Elongated member **420** passes through loop **415**, defining a pair of arms **422**, indicated as arm **422a** and **422b**. Each arm **422** has a respective end **421**, shown as end **421a** and **421b**, each forming a loop **425**, shown as loop **425a** and **425b**, to support one of a pair of grips **423**, shown as grip **423a** and **423b**. Elongated member **420** also includes a pair of lengthening devices or buckles **435**, shown as buckle **435a** and **435b**, at either end of a central strap **429**. Either one or both of buckles **435** provide for the adjustment of the length of elongated member **420**. Specifically, strap **429** has a pair of ends **431**, indicated as **431a** and **431b**, that pass through buckle **435a** and **435b**, respectively. As described subsequently, elongated member **420** is sub-

stantially inelastic, with the length of the elongated member being adjustable through the action of one or both of the pair of buckles 435.

FIGS. 4, 5A and 5B present several views of anchor 410, where FIG. 5A is a perspective view of the anchor and FIG. 5B is a sectional view 5B-5B of the anchor. As noted previously, anchor 410 includes an inelastic, flexible strap 413. In one embodiment, the majority of lengths of anchor 410 and elongated member 420 are formed of materials that include, but are not limited, to straps of a webbing of a natural or synthetic material having strength sufficient to support the weight of a device user. Webbing materials include, but are not limited to, one or more of a nylon, polypropylene or other polymeric fibers. It is to be understood that a single length of flexible material can alternatively comprise two or more pieces that are stitched, glued, or otherwise attached to one another. In one embodiment, the length of strap 413 is from 6 to 18 inches. In another embodiment, the length of strap 413 is approximately 12 inches.

Strap 413 has an enlarged first end 411 that is wider than the strap, and a second end 417 that is attached to the strap so as to form loop 415. As shown in FIG. 5B, strap 413 has an end 502 forming the core of first end 411. Since one of the intended uses of anchor 410 is to anchor exercise device 400 between a door and jamb, it is preferable that the end 411 include materials that are soft enough to prevent damage to a wood door or door frame and sturdy enough to support the weight of a user. One embodiment that is soft and sturdy is shown in FIG. 5B. Specifically, strap end 502 is partially surrounded by a recessed enclosure 505 and a pillow 507 that covers the strap end and the enclosure. Strap end 502 can further be held within end 411 by gluing and stitching the strap end to enclosure 505 and pillow 507, and by closing the pillow with one or more stitches 509. Strap 413 passes into first end 411 through a slot 504 in enclosure 505 and through slot 501 in pillow 507. In one embodiment, first end 411 is approximately 3.5" by 2.5" and is oriented approximately perpendicular to strap 413. In another embodiment, enclosure 505 is formed of a high-density, closed cell foam, and that pillow 507 is formed from a felt, and includes stitches 503. Alternatively, a second strap or piece of another material could be sewn, glued or otherwise attached to the end of strap 413 to form end 502. In another alternative embodiment, enclosure 505 can include another rigid member, such as a metal or hard plastic plate, to increase the rigidity of strap end 411.

Elongated member 420 is shown in greater detail in FIGS. 6-9, where FIG. 6 is a schematic top view of the elongated member, FIG. 7 is a perspective view of one of the pair of grips 421 and the corresponding one of the pair of buckles 435, FIG. 8 is a sectional view 8-8 of one of the pair of grips 421, and FIG. 9A is a perspective view showing details of one of the pair of buckles and the adjoining strap 429. As shown in FIG. 6, the elongated member 420 has length S, and includes two inelastic strap portions 427, indicated as 427a and 427b, strap 429 and the pair of buckles 435 for adjusting the length S. The portion of elongated member 420 from each end to the nearest buckle has a fixed length—that is, each of the two portions from one of the pair of ends 421 to the corresponding one of the pair of buckles 435 has a fixed length. In one embodiment, the length S is adjustable over a length that allows for a wide range of exercises. Thus, for example and without limitation, length S can be varied in length from approximately 6 feet to 12 feet. In another embodiment, elongated member 420 has a width of approximately 1.5". When used for exercising, strap 429 and loop 415 can slide the elongated member 420 along anchor 410, while

providing enough friction so that there can be some mismatch in forces on the two ends 421 without the elongated member sliding through the anchor while a user is exercising.

The details of one of the pair of ends 421, including strap 429 to grip 423, and including buckle 435 are shown in FIGS. 7, 9A and 9B. Buckle 435 is a cam buckle, the design and use of which are well known in the art. Buckle 435 is attached to strap 427, and thus the length of each of end 421 is not adjustable. Buckle 435 is also slidably accepts and grips strap 429, allowing for adjustment of the length S.

Buckle 435 has a frame 709, a first strap bar 705, a second strap bar 707, and a user movable cam 711. First strap bar 705 supports a loop of strap 427 that is preferably secured by stitches 703. Alternatively, strap 427 can be secured to bar 705 through a second member, such as another looped strap or a plastic or metal piece that loops about bar 705 and provides a location to attach strap 427. Strap 427 has an opposite end that is bound with stitches 701 to form loop 425 to secure grip 423, as described subsequently. Second strap bar 707 and cam 711 supports strap 429. It is to be understood that the use of stitches as described herein to fasten strap portions can also be accomplished through the use of other methods of fastening, such as glue or by melting strap portions together.

Cam 711 is spring loaded such that it normally restrains a strap 429, and that under the action of a user, such as by pushing or pulling the cam, the cam is moved to allow the strap to move. The distance between cam 711 and bar 707 is adjusted by the user and a spring within buckle 435 by pushing on cam 711, allowing strap 429 to slide between cam 711 and bar 707. Thus, the length S can be adjusted by the user actuating cam 711 of buckle 435.

Grip 423 is shown in greater detail in the sectional view of FIG. 8. Grip 423 has a generally tubular shape, with an outer cover 801 and an inner cylindrical tubular portion 803. Cover 801 has a length and outer diameter to allow a hand to easily grab grip 423, and is formed from a material that permits a user to hold it while exercising. In one embodiment, the material for cover 801 is a high-density foam. Portion 803 provides the strength of grip 423 and can be formed from a length and diameter of plastic or other rigid material to match the size of cover 801 and to provide space for a loop 425 to pass through the center of portion 803. In one embodiment, portion 803 is formed from a rigid and light material, such as PVC tubing.

One of the pair of free ends 431 is shown in greater detail in FIG. 9A. Each end 431 is preferably folded back, and is held in place, for example by a stitch 901, to form an easily manipulated end. Elongated member 420 also includes several sleeves, shown as sleeves 903, 905a and 905b that twice surrounds strap 429 to prevent ends 431 from moving about. Specifically, sleeves 903 and 905 are placed between buckles 435, ends 431 and strap 429. Thus sleeves 903 and 905 restrain the portion of strap 429 from a buckle 435 to the corresponding end 431 from moving about as exercise device 420 is moved. As shown in FIG. 9A, sleeve 903 is affixed near end 431, while sleeves 905 can be slid along the length of strap 429. FIG. 9B is a sectional view 9B-9B of FIG. 9A showing details of the cam buckle and attachment of sleeve 905b. In particular, FIG. 9B shows a bar 907 that spans buckle 435 and a strap 909 that is attached both the bar and to sleeve 905b. Strap 909 keeps sleeve 905b from sliding too far down strap 429 during adjustment of the length of the exercise device. It is preferred that sleeves 905b are elastic so that they can easily move and hold together the portions of strap 429.

Alternative Anchor Embodiments

Several anchor embodiments are shown in FIGS. 14A, 14B, 23 through 26, and 29 through 32A-32C. Except where

explicitly stated, any of the anchors may be used to support any of the elongated members of the exercise device. In the following discussion, the anchor embodiments are meant to be illustrative and not to be limiting. Thus, for example and without limitation, embodiments of an exercise device can be anchored in a door, about a pole, railing or stanchion, from a hook installed in a wall, or can be permanently affixed to a wall or exercise structure, for example.

FIG. 14A is a second embodiment of an anchor 1410 that can be used for attaching the exercise device to a pole or railing, and FIG. 14B is an embodiment of an exercise device anchored to a pole using the alternative anchoring embodiment of FIG. 14A.

FIG. 14A shows alternative embodiment anchor 1410 which includes an adjustable loop 1419 and an anchor loop 1415. As described subsequently, anchor 1410 is an alternative anchor, and can, for example, present an anchor loop 1415 for accepting elongate member 420 to form an exercise device 1400. Alternatively, anchor 1410 can support elongate member 120 or any of the other elongate members described herein. Adjustable loop 1419 is formed from a flexible strap 1411 and a cam buckle 1412 as follows. Cam buckle 1412 can be, for example, cam buckle 435 shown in detail in FIG. 9B. Flexible strap 1411 has a free, first end 1414 that is threaded through the cam portion of cam buckle 1412, for example by threading the strap between the second strap bar 707 and movable cam 711 of cam buckle 435. Flexible strap also has a second end 1418 that is attached to cam buckle 1412, for example, by looping the second end about first strap bar 705 of cam buckle 435 and providing a stitching 1416 through a double thickness of strap 1411. Strap 1411 thus threaded through buckle 1412 has forms an adjustable loop 1419 that can be increased or decreased in size by actuating cam buckle 1412 to release strap 1411, moving the strap through the cam buckle, and releasing the cam. End 1414 is held against strap 1411 by a slack sleeve 1413. An anchor loop 1415 is attached to strap 1411 by a stitching 1417.

It is preferred that the majority of lengths of anchor 1410 are formed of materials that include, but are not limited, to straps of a webbing of a natural or synthetic material having a strength sufficient to support the weight of a device user. Webbing include, but are not limited to, webbings made of one or more of nylon, polypropylene or other polymeric fibers. It is understood that alternative embodiments of a single length of flexible material include, but are not limited to, two or more pieces that are stitched, glued, or otherwise attached to one another.

FIG. 14B shows exercise device 1400 formed from anchor 1410 and elongated member 420. Adjustable loop 1413 of anchor 1410 is tightened about a pole P, for example, by placing the adjustable loop over the top of the pole and tightened using cam buckle 1412. Alternatively, strap 1411 can unthreaded from cam buckle 1412, wrapped about pole P, and then threaded through the cam buckle and tightened. In either case, end 1414 is the pulled through cam buckle 1412 and adjustable loop 1419 is tightened about pole P with sufficient force to allow exercise device 1400 to support a user's weight.

In addition to being attached to a pole, anchor 1410 can be tensioned to support exercise device 1400 about a railing, post, or other member. Alternately, the anchor can be attached to a carabineer that is fixed to a wall or other structure.

FIG. 23 shows a third embodiment of an anchor 2300 including a flexible strap 2301 with a first end 2305 having a loop 2307 held in place with stitching 2311 and a second end 2303 having a ring 2304 held within a loop created by stitching 2309, and FIG. 24 illustrates the use of anchor 2300 to anchor the elongated member 420, which could also be elon-

gated member 120, to a tree. In one embodiment, ring 2304 is a gated ring, such as a carabineer. In another embodiment, ring 2304 is a snap ring. It is preferred that the majority of lengths of strap 2301 are formed of materials that include, but are not limited, to straps of a webbing of a natural or synthetic material having a strength sufficient to support the weight of a device user. Preferred webbings include, but are not limited to, webbings made of nylon, polypropylene or other polymeric fibers. FIG. 24 shows an exercise device 2400 formed from anchor 2300 and elongated member 420. Strap 2103 is be wrapped about a tree with ring 2304 accepting the strap. Loop 2307 accepts strap 429, allowing the user to exercise against a tree or other object small enough for strap 2103 to be wrapped about.

FIGS. 25 and 26 shows a bracket 2500 for securing an anchor, such as the first end 411 of anchor 410, where FIG. 25 is a perspective front view of the bracket, and FIG. 26 illustrates the use of the bracket to anchor the exercise device. Bracket 2500 has a first flange 2503 with a mounting hole 2509 and a second flange 2505 with a mounting hole 2511 and a face 2507 that extends from the first flange to the second flange and includes a slot 2515 that extends into the face a face edge 2513 and includes a central slot 2517. In a preferred embodiment, bracket 2500 is formed from a single sheet 2501 of sheet metal, for example that has crease 2518 in flange 2503, crease 2523 in flange 2505, and creases 2519 and 2521 between face 2507 and flanges 2503 and 2505, respectively. In one embodiment, the thickness of sheet 2501 is from 0.05 to 0.10 inches, or more preferably approximately 0.0625 inches, and creases 2518, 2519, 2521, and 2523 are placed to such that face 2507 is parallel to and separated from flanges 2503 and 2505 by a distance D of from approximately 1 to 2 inches, or in another embodiment, approximately 1.5 inches. Mounting holes 2509 and 2511 are, in one embodiment, between approximately 1/4 inch and approximately 1/2 inch in diameter, and in another embodiment approximately 3/8 inch in diameter.

FIG. 26 illustrates the use of bracket 2500. Bracket 2500 is mounted to a wall W, and held in place by a pair of screws 2601 through mounting holes 2509 and 2511. A portion of anchor 410 is shown in phantom on the right side of FIG. 26, specifically enlarged portion 411 and flexible strap 413. Anchor 410 is placed in bracket 2500 as indicated by the arrow. Specifically, strap 413 is slid through the slot 2515 in face edge 2513, with enlarged portion between bracket 2500 and wall W and into central slot 2517. Slot 2515 is sized to be large enough to allow strap 413 to slide through the slot but not so large as to allow enlarged portion 411 to pass through the slot. The use of bracket 2500 allows for exercise device 400, which was previously shown as being mountable in a door jamb, to be mounted against any wall to which the bracket can be mounted.

Several embodiments provide an anchor for an exercise device formed of components that are removably attached. Thus, for example, embodiments include an anchor having a portion to attach to a structure that is removably attached to a portion to support an elongated member. Thus for example, and without limitation, any one of anchors 110, 410, or 2300 may include interlinking or interlocking components. This may permit the replacement or interchanging of anchor components or the addition of additional components, such as straps to lengthen the anchor.

FIG. 29 is a perspective view of an exercise device 2900 including a fourth embodiment of an anchor 2910 and a second embodiment of an elongated member 2920. Exercise device 2900, anchor 2910, and elongated member 2920 are generally similar to exercise devices 100 or 400, anchors 110,

11

410, or 2300 and elongated members 120 or 420, respectively, except further detailed below. Where possible, similar elements are identified with identical reference numerals in the Figures.

Anchor 2910 includes a ring 2911 that passes through loop 415 to form an extension of anchor 410. Ring 2911 is a closed or closable loop of material capable of supporting a user when exercising. The material of ring 2911 may be a metal or plastic having sufficient strength to support an exercising user. An alternative embodiment of ring 2911 is any loop capable of supporting elongated member 2920, and includes, but is not limited to, an open loop, a hook, a ring that deforms (as in a snap ring) or has a movable portion (as in a gated ring) to permit the ring to open or close. FIG. 29 illustrates, without limitation, one embodiment, where ring 2911 is a ring 2913 having a spring loaded gate 2915. In another alternative embodiment, anchor 410, which does not necessarily include loop 415, includes one or more holes, which are preferably reinforced with metal, through which ring 2911 may pass.

Elongated member 2920 includes a pair of buckles 2935, shown as buckle 2935a and 2935b. As shown in detail with respect to buckle 2935a, buckle 2935 includes a first ring 2931 and a second ring 2933 having a center bar 2932 and a tab 2936. Strap 427 is attached to both ring 2931 and 2933, and strap 429 passes through ring 2931, around bar 2932, and back through ring 2931. Buckle 2935a illustrates the buckle restraining straps 429 and 427. When tab 2932 is pulled to separate rings 2931 and 2933, as shown for buckle 2935b, the length of elongated member 2920 may be changed.

When configured for exercising, anchor 410 may pass through a door jamb, as described above, and strap 429 of elongated member 2920 passes through ring 2911 of anchor 2910.

FIG. 30 is a perspective view of an exercise device 3000 including a fifth embodiment of an anchor 3010 and elongated member 2920. Exercise device 3000 is generally similar to exercise devices 100, 400, or 2900, and anchor 3010 is generally similar to anchor 2910, except as explicitly detailed below. Where possible, similar elements are identified with identical reference numerals in the Figures.

Anchor 3010 includes anchor 2300 and ring 2911, where the ring passes through loop 2307. Anchor 3010 may be used to secure exercise device 3000 to one of a variety of supports with ring 2911 supporting elongated member 2920. In one embodiment, ring 2304 may be attached to a ring affixed to a structure. In another embodiment, strap 2301 may be looped about a structure. Thus, for example, FIG. 30 shows ring 2304 positioned to arrange strap 2301 in a loop 3001. Loop 3001 may, for example, be placed about a pole to support exercise device 3000.

FIG. 31 is a perspective view of an exercise device 3100 including a sixth embodiment of an anchor 3110 and elongated member 2920. Anchor 3110 includes anchor 2910 and an anchor loop 3112. Exercise device 3100 is generally similar to exercise devices 2900 or 3000, and anchor 3110 is generally similar to anchors 2910 or 3010, except as explicitly detailed below. Where possible, similar elements are identified with identical reference numerals in the Figures.

Anchor loop 3112 has a first portion 3111 for interacting with elongated member 2920 and a second portion 3113 for connecting to ring 2911 of anchor 2910. Anchor 2910 is described above with regard to the embodiment of FIG. 29. In one embodiment, the material of anchor loop 3112 may include, but is not limited, to a webbing of a natural or synthetic material having strength sufficient to support the weight of a device user. Webbing materials include, but are not limited to, one or more of a nylon, polypropylene or other

12

polymeric fibers. It is to be understood that a single length of flexible material can alternatively comprise two or more pieces that are stitched, glued, or otherwise attached to one another. In another embodiment, the material of elongated anchor loop 3112 includes or is formed entirely of a metal or a plastic. When configured for exercising, anchor 410 may pass through a door jamb, as described above, and strap 429 of elongated member 2920 passes through first portion 3111 of anchor loop 3112.

FIGS. 32A, 32B, and 32C are views of one embodiment of anchor loop 3112, or a portion thereof, where FIG. 32A, is a perspective view of anchor loop 3112 and ring 2911, FIG. 32B is perspective view of the anchor loop unfolded, and FIG. 32C is an end view of the anchor loop ready to accept a ring. Anchor loop 3112 of FIGS. 32A, 32B and 32C is generally similar to the anchor loop of FIG. 31, except further detailed below. Where possible, similar elements are identified with identical reference numerals in the Figures.

As shown in FIG. 32A, anchor loop 3112 includes a strap 3205 that forms first portion 3111 and second portion 3113. Second portion 3113 includes a first loop 3201 and a second loop 3203 that are formed or attached to strap 3205. As shown in FIG. 32B, loops 3201 and 3203 are on opposite ends of strap 3205 and are offset so that loops 3201 and 3203 align when strap 3205 is folded to form second portion 3113 as shown in FIG. 32C.

When assembled for exercising, strap 3205 is folded to align loops 3201 and 3203, and ring 2911 is placed through the aligned loops. Ring 2911 is also attached to anchor 410, which may be placed through a doorjamb. Elongated member 2920 is placed through second portion 3111, and a user may exercise as described herein.

FIG. 33 is a perspective view of a seventh embodiment of and anchor 2910, where ring 2911 of the fourth embodiment exercise device 2900 is replaced with a hook 3301. Hook 3301 allows for the joining of loop 415 and/elongated member 2920. FIG. 33 illustrates hook 3301 as S-hook having a first hook portion 3303 on which loop 415 is attached and a second portion 3305 on which elongated member 2920 is attached.

While exercise device 100, and more specifically exercise devices 400, 2900, 3000, and 3100 have been described with respect to a particular embodiment, there are many alternative embodiments. Thus, for example, there are many embodiments that provide for an adjustable length, substantially inelastic, strap-like member that has an easily adjustable length and balance of the two sides of the strap-like member about the anchor.

Alternative Grip Embodiments

The use of exercise device 100 is determined by the grips available to a user. Grips allow the user to grip, such as by squeezing with sufficient force to support her weight, and include devices that can hold the user within a loop or hook as the user pulls on the exercise device. In this context, a "grip-able" portion refers to the ability to either wrap a body part around and squeeze that portion of the grip, or place a portion of the body through a loop or hook of the grip so that the user can pull against the exercise device and keep the body part within the grip.

Grips are usable for applying forces to various part of the body, including the neck, all or part of the hand, arms, legs, toes, or the heel. Several embodiments of grips are described herein as grips that may be used, for example and without limitation, by the hand, foot, or fingers. The grips described herein may be integral to device 100 or, alternatively, may be attached to, or attachable to, one of the pair of grips that are part of an exercise device, including but not limited to grips

123. The term “accessory” grip is used herein to denote a grip that may be attached to an existing grip on exercise device **100**. It is to be understood that the scope of the present invention extends to the integral information of the accessory grips into exercise device **100**.

The user may choose to exercise with the pair of grips having the same or different accessories, or without a grip accessory. In addition, several embodiments of the exercise device include a grip attachment portion to removably attach the grip of an exercise device, such as exercise device **100** or any exercise device having two grips, and a portion that is grippable by the hand, foot, fingers, or other parts of the body. The use of grip accessories allow a user to build additional strength in the hand or fingers by providing for different types of hand or finger gripping, and allows for additional exercises to be performed, as with the foot grip accessory. In addition, the pair of grips can be coupled, as discussed in reference to FIGS. **16A** and **16B**, allowing a user to exercises using one grip accessory.

One alternative embodiment grip is shown in FIGS. **10** and **11**, where FIG. **10** is a schematic top view of an alternative elongated member **1020** having one cam buckle **435** as a lengthening device, and two finger grips **4001**, and FIG. **11** is a sectional view **11-11** of alternative finger grips. The use of one buckle **435** provides a lighter exercise device **400**, but results in a smaller useful range of lengths for elongated member **1020**. Finger grips **4001** include four holes **4101** for the user’s fingers, and allows for exercise of one or more finger muscles.

One example of a grip accessory is foot grip accessory **1700**, which is illustrated in FIGS. **17A-17B** as being attached to grips **123** of exercise device **100**. Specifically, FIG. **17A** illustrates foot grip accessory **1700** attached to exercise device **100** and gripped by toes T, and FIG. **17B** illustrates a pair of foot grip accessories, one on each of the pair of grips **123**, and each grasped by one of the user’s heel H1 and H2. Each foot grip accessory **1700** has a flexible loop **1710** and a grip attachment portion **1720**. It is preferred that the portion of loop **1710** that extends from grip **123** is approximately 12 inches long to provide enough room for either a user’s heel or toe fit through the loop. With foot grip accessory **1700** so secured, the toes (FIG. **17A**) or heel (FIG. **17B**) can be placed through loop **1710**, and a force can be exerted by the foot against exercise device **100**.

It is preferred that the majority of foot grip accessory **1700** is formed of materials that include, but are not limited, to straps of a webbing of a natural or synthetic material having a strength sufficient to support the weight of a device user. Preferred webbings include, but are not limited to, polymeric fiber webbings made of, for example, nylon or polypropylene or some other polymeric fiber. It is understood that a single length of flexible material can alternatively comprise two or more pieces that are stitched, glued, or otherwise attached to one another.

In a first embodiment foot grip accessory **1700**, flexible loop **1710** is removably attachable, as discussed subsequently, to one of the pair of grips **123**. A specific embodiment of foot grip accessory **1700** is illustrated in FIGS. **18A-D**, where FIG. **18A** is a perspective view of the foot grip accessory, FIG. **18B** is a bottom view of the foot grip accessory, FIG. **18C** is a side view of part of one of the grip attachment portions, and FIG. **18D** is a top view of part of one of the grip accessory attachment portions. As shown in FIGS. **18A** and **18B**, foot grip **1700** is formed from three straps: a loop strap **1801** and two attachment straps **1803**. With the three straps

attached, as described subsequently, loop strap **1801** forms loop **1710** and the two attachment straps **1803** forms the grip attachment portion **1720**.

Loop strap **1801** is formed from a length of strapping having ends that are joined to form a loop. Loop strap **1801** is preferably polymeric fiber webbing 20 inches long and 1.5 inches wide. In the preferred embodiment, the loop includes two triangular shaped double stitched portions **1815**, one of which joins the two ends of loop strap **1801**. Each of the two grip attachment straps **1803** is formed from a length of strapping having a first end **1807** with a first fastening surface **1809** and a second end **1811** with a second fastening surface **1813**. Attachment straps **1803** are preferably polymeric fiber webbing. In one embodiment straps **1803** have a length of 7.5 inches and a width of 1.5 inches. Fastening surfaces **1809** and **1811** are, in one embodiment, attached to loop strap **1801** by double stitching **1817**, and grip attachment straps **1803** are preferably joined midway between ends **1807** and **1811** to the loop strap by double stitching **1805**.

Each attachment strap **1803** includes fastening surfaces **1809** and **1813** are on opposite sides of the strap. In one embodiment, fastening surfaces **1809** and **1813** are matching surfaces, such as matching hook and loop surfaces of a hook and loop fastening system, such as VELCRO® brand hook and loop fasteners. In one embodiment, fastening surfaces **1809** and **1813** are each approximately 2 inches by 1.25 inches.

Foot grip accessory **1700** is removably attachable and is used as follows. Grip attachment portion **1720** of foot grip accessory **1700** is removably attachable to one of the pair of grips **123**, by wrapping the length of each strap **1703** about grip **123a** and contacting fastening surfaces **1809** and **1813** on each strap **1803**. Stitching **1815** allows loop **1710** to open without twisting and provides a secure strap for securing the foot.

Another example of a grip accessory is finger grip accessory **1900**, which is illustrated in FIGS. **19A-19C** with three different exercises when attached to grips **123** of exercise device **100**. Finger grip assembly **1900** has loops **1910** adapted for receiving and being gripped by the thumb and one or more fingers and a grip attachment portion **1920** for attaching the accessory to the grip of an exercise device. Grip attachment portion **1920** is removably attachable to one of the pair of grips **123**. In one embodiment, there are two loops **1910**: a first loop **1910a**, and a second loop **1910b**. With finger grip accessory **1900** so secured, a finger F1 can be placed through one of the loops, for example first loop **1910a** as shown in FIG. **19A**, a finger F1 can be placed through the first loop and a finger F2 can be placed through second loop **1910b** as shown in FIG. **19B**, or two fingers, F1 and F2 can be placed through the first loop and a finger F3 and a finger F4 can be placed through the second loop, as shown in FIG. **19C**.

In one embodiment, each of the pair of grips **123** is provided with one finger grip accessory **1900**. With the finger or fingers so placed through at least one of loops **1910**, a force can be exerted by the pulling against exercise device **100**. Finger grip accessory **1900** has similar functionality as finger grips **4001**.

A specific embodiment of finger grip accessory **1900** is illustrated in FIGS. **20A-C**, where FIG. **20A** is a perspective view of the finger grip accessory, FIG. **20B** is a top view **20B-20B** of the finger grip accessory, and FIG. **20C** is a sectional side view **20C-20C** of the finger grip accessory. Finger grip accessory **1900** includes two loops **1910**, first loop **1910a** and second loop **1910b**, and grip attachment portion **1920** includes three portions **1920a**, **1920b**, and **1920c**. More specifically, finger grip accessory **1900** is

formed from five straps: a loop strap **2001**, three attachment straps **1803**, and a backing strap **2003**. With the five straps attached, as described subsequently, loop strap **2001** forms first loop **1910a** and finger loop **1910b**, that can each receive one or more fingers, and each of the three attachment straps **1803** forms one of grip attachment portion **1920a**, **1920b**, and **1920c**. It is preferred that the majority of finger grip **1900** is formed of the same materials as hand grip **1700**.

In one embodiment, loop strap **2001** is constructed from a polymeric fiber webbing having a length of 21.5 inches long and a width of 1 inch, and backing strip **2003** is a polymeric fiber webbing having a length of 2 inches and a width of 1 inch. Finger grip accessory **1900** is assembled by three stitches **2007** that each pass through one of the three attachment straps **1803** and through loop strap **2001** and backing strap **2003**. In the preferred embodiment, stitching **2007** is double stitched portions. As is shown in FIGS. **20A** and **20C**, a portion of loop strap **2001** protrudes between each of the three attachment straps **1803** to form loops **1910a** and **1910b**. It is preferred that loops **1910a** and **1910b** are formed from lengths of loop strap **1901** that are approximately 8 inches. Loop strap **2001** preferably extends the length of backing strap **2003**, with two loops **1910a** and **1910b** between adjacent attachment straps **1803**.

Finger grip accessory **1900** is removably attachable and is used as follows. Grip attachment portion **1920** of finger grip accessory **1900** is removably attachable to one of the pair of grips **123** by the contact of fastening surfaces **1809** and **1813** on each strap **1803**. With finger grip accessory **1900** so secured, a finger may be placed through one of the loops, for example loop **1910a** as shown in FIG. **20A**, one finger can be placed through each of loop **1910a** and **1910b** as shown in FIG. **20B**, or two fingers can be placed through each of loop **1910a** and **1910b** as shown in FIG. **20C**. With the finger or fingers so placed through at least one of loops **1910**, a force can be exerted by the user against exercise device **100**.

A third example of a grip accessory is grip accessory **2100**, which is illustrated in FIGS. **21A-21C** as being attached to grips **123** of exercise device **100**. Grip accessory **2100** has several cords **2110** that can be gripped in different combinations, as explained subsequently, and a grip attachment portion **2120**. In general, the number of cords **2110** can be from one to five, or more, with four being the number in one embodiment, and with each cord having the same diameter and length. In one embodiment cords **2110** have a grippable length large enough for a human hand, for example a length from 4 inches to 6 inches, and that there is enough additional length to allow the user to pass her hand between cords, as illustrated in FIGS. **21A-21C**. In one embodiment, grip accessory **2100** has four cords, denoted as a first cord **2110a**, a second cord **2110b**, a third cord **2110c**, and a fourth cord **2110d**. The cords can be gripped in almost any combination so that a user can grip any number of cords, from one cord to all 4 cords. FIG. **21A** illustrates hand H gripping three cords, for example the first cord **2110a**, second cord **2110b**, and third cord **2110c**, FIG. **21B** illustrates the hand gripping two cords, for example the first and second cords, and FIG. **21C** illustrates the hand gripping one cord, for example the first cord.

Grip attachment portion **2120** is removably attachable, as discussed subsequently, to one of the pair of grips **123**. With grip accessory **2100** so secured, between one and all of cords **2110** can be gripped, and a force can be exerted by pulling against exercise device **100**. In one embodiment, each of the pair of grips **123** is provided with one grip accessory **2100**.

One embodiment of grip accessory **2100** is illustrated in FIGS. **22A-D**, where FIG. **22A** is a perspective view of the grip accessory, FIG. **22B** is a top view of the grip accessory,

FIG. **22C** is a bottom view of the grip accessory, and FIG. **22D** is sectional side view **22D-22D** of FIG. **22C**. Grip accessory **2100** is formed from four straps, specifically a backing strap **2205**, a front strap **2207**, and two attachment straps **1803**, and two cords **2201** and **2203**. Cords **2110** are formed from two longer cords **2201** and **2203**, and grip attachment portion **2120** is formed from straps **2205**, **2207**, and **1803**.

The two straps **1803** forming grip attachment portion **2120** are attached at their respective central portions between the ends of backing strap **2205** and front strap **2207**. The four cords **2110a-d** are formed from the longer cords **2201** and **2203**. Specifically, as shown in FIG. **22B**, cords **2201** and **2203** are side-by-side and folded in half. Each cord forms a loop **2213** near the middle of cords **2201** and **2203**, with both cords lashed together by whipping **2211** and to form a loop **2213** and with the four ends of cords **2201** and **2203** lashed by whipping **2209**. In the sectional view of FIG. **22D**, cord **2203** is shown with a first end **2213** and second end **2217** lashed together by whipping **2209**, and a central portion **2215** forming loop **2213** about strap **2207**. Each cord **2201** and **2203** is folded in half, and thus each cord forms two cords between whippings **2209** and **2211**. Specifically, cord **2201** forms cords **2210a** and **2210b**, and cord **2203** forms cords **2210c** and **2210d**.

In one embodiment, straps **2205** and **2207** are polymeric fiber webbings, backing strap **2205** has a length of 5 inches and a width of 1 inch, and front strap **2207** preferably has a length of 6 inches and a width of 1 inch. Cords **2201** and **2203** are, in one embodiment, cotton cord having a length of from approximately 20 inches to approximately 30 inches, and, in another embodiment, have a length of from approximately 22 inches to approximately 26 inches. In yet another embodiment, the length is approximately 24 inches. In one embodiment, cords **2201** and **2203** have a diameter that is preferably from $\frac{1}{2}$ inch to 1 inch, or, in another embodiment, approximately $\frac{3}{4}$ inches. The joints between straps **2205** and **2207** and attachment straps **1803** are preferably double stitched. The resulting grip attachment **2100** has four cords with approximately 10 inches of grippable length, allowing enough room for a human hand to pass between and grip cords **2110**.

Grip accessory **2100** is removably attachable and is used as follows. Grip attachment portion **2120** is removably attachable to one of the pair of grips **123** by the contact of fastening surfaces **1809** and **1813** on each strap **1803**. With finger grip accessory **2100** so secured, one, two, three, or all four of cords **2110a-d** may be gripped by the hand. For example, FIG. **22A** illustrates cords **2110a**, **2110b**, and **2110c** gripped by a user, FIG. **22B** illustrates cords **2110a** and **2110b** gripped by a user, and FIG. **22C** illustrates cord **2110a** gripped by a user. With cords **2110** so gripped, a force can be exerted by the user against exercise device **100**.

FIG. **27** is a perspective view of a grip which may be used as either a hand grip or a foot grip, and which is referred to herein without limitation as a "combination" grip **2700**. Grip **2700** may be generally similar to the grips or accessory grips of exercise device **100**, except as explicitly detailed below. Where possible, similar elements are identified with identical reference numerals in the Figures.

In general, combination grip **2700** includes two elements which may be used as grips, which may be at one end or at both ends of the exercise devices described herein including, but not limited to, exercise device **100** or **400**. Thus, for example, combination grip **2700** may be at both of ends **121**, on both of ends **421**, or on one of ends **421a** or **421b**. In the embodiment of FIG. **27**, grip **2700** includes a hand grip **423a** supported by loop **425a** from strap **427a**. Specifically, the

material of strap **427a** continues through loop **425a** and is affixed to the strap by stitching **2711**. Grip **2700** further includes a loop **2710** supported at end **421a**.

In one embodiment, loop **2710** is a strap formed from one or more inelastic pieces that are attached together to form a continuous loop through portion **803**, and the loop is thus integrally attached to hand grip **423**. Thus, for example, hand grip **423a** has a first end **423a-1** and **423a-2** that correspond to a first end **802-1** and a second end **803-2**, respectively, of inner cylindrical tubular portion **803**. In one embodiment, loop **2710** is formed from one or more pieces of webbing with ends sewed together form a single loop through portion **803**, resulting in a portion of the loop hanging below the hand grip.

FIG. **28** is a perspective view of a second embodiment of a combination grip **2800** which may be generally similar to grip **2700**, except as explicitly detailed below. Where possible, similar elements are identified with identical reference numerals in the Figures.

Combination grip **2800** includes a flexible loop **2810** that includes a strap **2811** having an end **2812**, and a length adjustment mechanism **2813**. Strap **2811** passes through tubular portion **803** and length adjustment mechanism **2813** permits the size of loop **2810** to be adjusted by moving end **2812** through the mechanism. Mechanism **2813**, which may be, for example, a cam buckle, as illustrated, or a VELCRO® brand hook and loop fastener, permits the user to adjust the length of loop **2810** to the user's body size. Strap **2811** may either be removable from hand grip **423a**, or may have ends that are too large to permit removal of the grip, and thus is not removable from the hand grip. In an alternative embodiment (not shown), strap **2811** and end **2812** have matching fasteners, such as a VELCRO® brand hook and loop fastener, to prevent dangling of the strap end.

In one embodiment, grip **423** is 5 inches long, and loop **2710** is approximately 20 inches long. In another embodiment, a portion of loop **2710** that is not within portion **803** is padded with $\frac{1}{8}$ inch of a soft material, including but not limited to a rubber based on polychloroprene, such as neoprene. In another embodiment, and loop **2810** is adjustable from approximately 12 inches long to approximately 23 inches long.

In yet another embodiment, loop **2711** or **2811** does not form a loop through portion **803**, but is attached at or near the ends **803-1**, **803-2**.

Methods Of Exercising

The use exercise device **120** is illustrated in FIGS. **12A-12D**, where FIG. **12A** is an initial configuration, FIG. **12B** illustrates lengthening the elongated member **420**, further illustrated in FIGS. **12B'** and **12B''**, FIG. **12C** shows the application of force to the shorter leg of the elongated member, and FIG. **12D** shows the application of force to the grips during an exercise. FIGS. **12A-12D** are illustrative, and in general apply to the exercise devices of the present invention.

For illustrative purposes, FIG. **12A** is assumed to be an initial configuration of an anchored device, and it is assumed that the user wishes to increase the length *S* while keeping the pair of arms **422** the same length (approximately one half of *S*). First, the user actuates one or both buckles **435**. FIG. **12B** schematically shows the result of actuating buckle **435a** and elongating leg **422a** as indicated by the arrows on that figure. FIG. **12B'** shows the user *U* pushing cam **711** and grabbing end **431**, and FIG. **12B''** shows the user pulling end **431** away from the cam, as indicated by the arrow, to shorten the device.

The user then preferentially pulls on the shorter leg **422b** as indicated by force vector *F1* of FIG. **12C**. With both of the pair of legs **422** having approximately the same, longer length the user can then exercise, as indicated in FIG. **12D**, by applying

equal forces *F2* to each handle grip. In practice, it is not necessary for the two forces of FIG. **12D** to be equal, as the application of force to legs **422** away from anchor **410** increases the friction between elongated member **420** and the anchor, allowing the lengths to not change, even under some mis-match of applied forces. Alternatively, exercise device can be adjusted to provide shorter legs **422** by pulling on end **431** to shorten the length *S*.

In addition to being equally balanced between the two arms, it is possible to use the inventive device to provide differing arm lengths for exercising. FIGS. **13A-13C** illustrate the use of an exercise device having differing lengths of arms **422**, where FIG. **13A** is an initial configuration, FIG. **13B** shows the application of force to one of the pair of arms **422**, and FIG. **13C** shows the application of force to the grips during an exercise. For illustrate purposes, FIG. **13A** is assumed to be an initial configuration of an anchored device, and it assumed that the user wishes to adjust the length of arms **422** to different lengths. First, the user preferentially pulls on the shorter leg **422b** as indicated by force vector *F1* of FIG. **13B**. The user can then exercise, as indicated by the equal forces *F2* of FIG. **13C**. In practice, it is not necessary for the two forces of FIG. **13C** to be equal, since as illustrated in FIG. **12**, as the application of force to legs **422** away from anchor **410** increases the friction between elongated member **420** and the anchor also increases. This limits the possibility that the arm lengths will change, even under some mis-match of applied forces. The adjustment of arms **422** to different lengths can be combined with the lengthening or shortening of the length *S* by actuating one or both of buckles **435**.

The inventive exercise device allows for a wide range of exercises. Examples of the many exercises that are possible are presented in TABLE 1 for the inventive device placed over the top of a door. FIGS. **3** and **15** illustrate three of the many exercise positions. In each of these positions the user has selected a length for exercise device **100** or **400**, adjusted as explained with reference to FIG. **12** or **13**, has positioned himself on the ground a desired horizontal distance *X* from anchor point *A* with a portion of his weight being supported by the exercise device. With his weight so supported, as shown in FIGS. **3** and **15**, he moves his body in directions appropriate to the type of exercise to be performed, for example by moving his body toward or away from the wall or ground, by bending his arms or legs while supporting his weight by the exercise device, or performing other movements that exercise his muscles.

Specifically illustrated in FIGS. **3** and **15** are single poses of a user *U* performing a variety of exercises including a high row exercise (FIG. **3**), a reverse combination crunch (FIG. **15A**), a single leg L-squat (FIG. **15B**), a gymnast dip (FIG. **15C**), a kneeling combination crunch (FIG. **15D**), a lying leg curl (FIG. **15E**), a hip lift (FIG. **15F**), a front shoulder raise (FIG. **15G**), a crunch (FIG. **15H**), and a triceps extension (FIG. **15I**). It is apparent from FIGS. **3** and **15** that many different types of exercises are possible with the inventive exercise device according to the length of the device, the positioning of the body, and how the handles are gripped. In addition, the inventive device can be used to perform one handed exercises as illustrated in FIGS. **16A** and **16B**. Specifically, FIG. **16A** shows an exercise device **400'** having interlocking the ends **421a** and **421b** for one handed exercises, and FIG. **16B** illustrates the use of the exercise device **400'** in performing a one arm high row exercise.

TABLE 1

Several Basic, Intermediate, and Advanced Over the Door Anchor Exercises.		
Basic Exercises	Intermediate	Advanced
Pull functions	Pull functions	Pull/lateral functions
Low row	One-arm low row	Lateral raise
High row	One-arm high row	Front shoulder raise
Pull-up	One-arm pull-up	Reverse-grip curl
High curl	One-arm high curl	Combination row/kickback
Low curl	One-arm low curl	Internal rotator cuff
Back fly	Lower chest/lat crunch	External rotator cuff
Wrist curl	Reverse-grip wrist curl	2-Way forearm flexors
Core Strength	Core Strength	Core Strength
Crunch	Kneeling combination crunch	Standing combination crunch
Reverse single leg raise	Reverse leg raise	Reverse leg raise w/ hip lift
Oblique crunch	V-sit-up	Reverse oblique raise
Reverse crunch	Hip lift	V-balance
Bicycle	Reverse bicycle	Reverse combination crunch
Back Bridge		
Legs	Legs	Legs
Squat	Lying hamstring pedal	Lying hamstring curl
Hip hinge	Tip-toe squat	Single-leg hip hinge
Squat lunge	Step-back lunge	Single leg L-squat
Sumo squat	Single leg squat	Diagonal Step-back lunge
Side-to-side lunge	Single calf raise	Crossover off-balance squat
Calf raise	Jumping Ski PT	
Push functions	Push functions	Push functions
Standard press	One-arm incline press	Triceps kickback
Chest fly	Low chest press (outside grip)	One-arm concentration fly
Shoulder press	Reverse Push-up	Reverse crunch/push-up
Overhead triceps extension	One-arm triceps extension	combo
Lat-Pullovers		One-arm shoulder press
		Gymnast dip

Although the invention(s) presented herein have been disclosed in the context of certain preferred embodiments and examples, it will be understood by those skilled in the art that the invention(s) extend beyond the specifically disclosed 40 embodiments to other alternative embodiments and/or uses of the invention(s) and obvious modifications and equivalents thereof. Thus, it is intended that the scope of the invention(s) herein disclosed should not be limited by the particular embodiments described above, but should be determined 45 only by a fair reading of the claims that follow.

What is claimed is:

1. An inelastic exercise device attachable to a structure, said exercise device comprising: 50
 an anchor attachable to the structure; and
 an elongated flexible member disposed between a first grip and a second grip;
 where said anchor includes a loop, where said loop supports said elongated flexible member at a position 55
 between said first grip and said second grip,
 where, with said anchor attached to the structure,
 said elongated flexible member is movable through said loop by the user pulling on said first grip or said second grip, and 60
 said elongated flexible member is removably connectable to said anchor,
 such that a user may exercise by pulling on said first grip and said second grip and supporting their weight by said structure, and 65
 such that a user may remove said elongated flexible member from said anchor when not exercising,

where said loop includes a substantially rigid material, and where said loop includes a gated ring.

2. The inelastic exercise device attachable to a structure of claim 1, where said substantially rigid material includes a metal.

3. The inelastic exercise device attachable to a structure of claim 1, where said substantially rigid material includes a plastic.

4. The inelastic exercise device attachable to a structure of claim 1, where said loop includes a hook.

5. The inelastic exercise device attachable to a structure of claim 1, where said loop is a first loop, and where said anchor includes a second loop of a flexible material.

6. The inelastic exercise device attachable to a structure of claim 5, where said flexible material includes a webbing.

7. The inelastic exercise device attachable to a structure of claim 1, where said anchor is attachable to a door jamb.

8. The inelastic exercise device attachable to a structure of claim 1, where said anchor includes said gated ring or a hook removably attachable to said loop, and where said loop is a flexible member including one or more openings sized to accept said gated ring or hook.

9. An inelastic exercise device attachable to a structure, said exercise device comprising:

an anchor attachable to the structure; and
 an elongated flexible member disposed between a first grip and a second grip;

where said anchor includes a loop, where said loop supports said elongated flexible member at a position 65
 between said first grip and said second grip,

21

where, with said anchor attached to the structure,
 said elongated flexible member is movable through said
 loop by the user pulling on said first grip or said
 second grip, and
 said elongated flexible member is removably connect-
 able to said anchor,
 such that a user may exercise by pulling on said first grip
 and said second grip and supporting their weight by said
 structure, and
 such that a user may remove said elongated flexible mem-
 ber from said anchor when not exercising,
 where said loop includes a substantially rigid material, and
 where said loop includes a snap ring.

10. The inelastic exercise device attachable to a structure of
 claim **9**, where said substantially rigid material includes a
 metal.

22

11. The inelastic exercise device attachable to a structure of
 claim **9**, where said substantially rigid material includes a
 plastic.

12. The inelastic exercise device attachable to a structure of
 claim **9**, where said loop includes a hook.

13. The inelastic exercise device attachable to a structure of
 claim **9**, where said loop is a first loop, and where said anchor
 includes a second loop of a flexible material.

14. The inelastic exercise device attachable to a structure of
 claim **13**, where said flexible material includes a webbing.

15. The inelastic exercise device attachable to a structure of
 claim **9**, where said anchor is attachable to a door jamb.

16. The inelastic exercise device attachable to a structure of
 claim **9**, where said anchor includes said snap ring or a hook
 removably attachable to said loop, and where said loop is a
 flexible member including one or more openings sized to
 accept said snap ring or hook.

* * * * *

UNITED STATES PATENT AND TRADEMARK OFFICE
CERTIFICATE OF CORRECTION

PATENT NO. : 8,469,864 B2
APPLICATION NO. : 13/251440
DATED : June 25, 2013
INVENTOR(S) : Randal Hetrick

Page 1 of 1

It is certified that error appears in the above-identified patent and that said Letters Patent is hereby corrected as shown below:

In the Specification, at Column 1, lines 4-11 please delete the section “Cross-Reference to Related Applications” as it currently reads, and insert the following:

--This application is a continuation of U.S. Patent Application No. 11/948,875, filed November 30, 2007, which claims the benefit of U.S. Provisional Application No. 60/973,129, filed September 17, 2007, the entire contents of which are hereby incorporated by reference herein and made part of this specification.--

Signed and Sealed this
Twenty-fifth Day of March, 2014



Michelle K. Lee
Deputy Director of the United States Patent and Trademark Office