

US008448880B2

(12) **United States Patent**
Hashish et al.

(10) **Patent No.:** **US 8,448,880 B2**
(45) **Date of Patent:** **May 28, 2013**

(54) **APPARATUS AND PROCESS FOR FORMATION OF Laterally Directed Fluid Jets**

(75) Inventors: **Mohamed Hashish**, Bellevue, WA (US);
Steve Craigen, Auburn, WA (US);
Bruce Schuman, Auburn, WA (US);
Eckhardt Ullrich, Kent, WA (US); **Jeno Orova**, Maple Valley, WA (US)

(73) Assignee: **Flow International Corporation**, Kent, WA (US)

(*) Notice: Subject to any disclaimer, the term of this patent is extended or adjusted under 35 U.S.C. 154(b) by 765 days.

(21) Appl. No.: **11/901,961**

(22) Filed: **Sep. 18, 2007**

(65) **Prior Publication Data**

US 2009/0071303 A1 Mar. 19, 2009

(51) **Int. Cl.**
B05B 7/04 (2006.01)
B05B 7/08 (2006.01)
B24C 5/04 (2006.01)

(52) **U.S. Cl.**
USPC **239/434**; 239/426; 451/102

(58) **Field of Classification Search**
USPC 239/398, 434, 407, 410, 413, 426,
239/429, 433; 451/36, 40, 102
See application file for complete search history.

(56) **References Cited**

U.S. PATENT DOCUMENTS

RE23,064 E * 12/1948 Tirrell 451/38
2,577,465 A * 12/1951 Jones et al. 451/90

3,624,966 A *	12/1971	Palmer	451/90
4,478,368 A	10/1984	Yie	
4,555,872 A	12/1985	Yie	
4,848,042 A	7/1989	Smith et al.	51/410
4,934,111 A	6/1990	Hashish et al.	
4,936,512 A	6/1990	Tremoulet, Jr.	
4,951,429 A	8/1990	Hashish et al.	
4,955,164 A *	9/1990	Hashish et al.	451/40
5,018,670 A	5/1991	Chalmers	
5,092,085 A	3/1992	Hashish et al.	
5,144,766 A	9/1992	Hashish et al.	
5,320,289 A	6/1994	Hashish et al.	
5,512,318 A	4/1996	Raghavan et al.	427/230
5,851,139 A	12/1998	Xu	
6,000,308 A	12/1999	LaFountain et al.	83/53
6,280,302 B1	8/2001	Hashish et al.	
6,283,832 B1	9/2001	Shepherd	
6,383,062 B1 *	5/2002	Jou	451/90
6,464,567 B2	10/2002	Hashish et al.	
6,752,686 B1	6/2004	Hashish et al.	
6,755,725 B2	6/2004	Hashish et al.	
6,875,084 B2	4/2005	Hashish et al.	
6,932,285 B1	8/2005	Zeng	

(Continued)

FOREIGN PATENT DOCUMENTS

DE 10225304 A1 12/2003
DE 20 2005 018 108 U1 2/2006

(Continued)

Primary Examiner — Len Tran

Assistant Examiner — Justin Jonaitis

(74) *Attorney, Agent, or Firm* — Seed IP Law Group PLLC

(57) **ABSTRACT**

A processing apparatus is provided to process a workpiece. The processing apparatus can have a low-profile nozzle system capable of navigating through spaces in order to process target regions with relatively small clearances. A fluid jet outputted from the nozzle system is used to cut, mill, or otherwise process the target region of the workpiece.

44 Claims, 13 Drawing Sheets

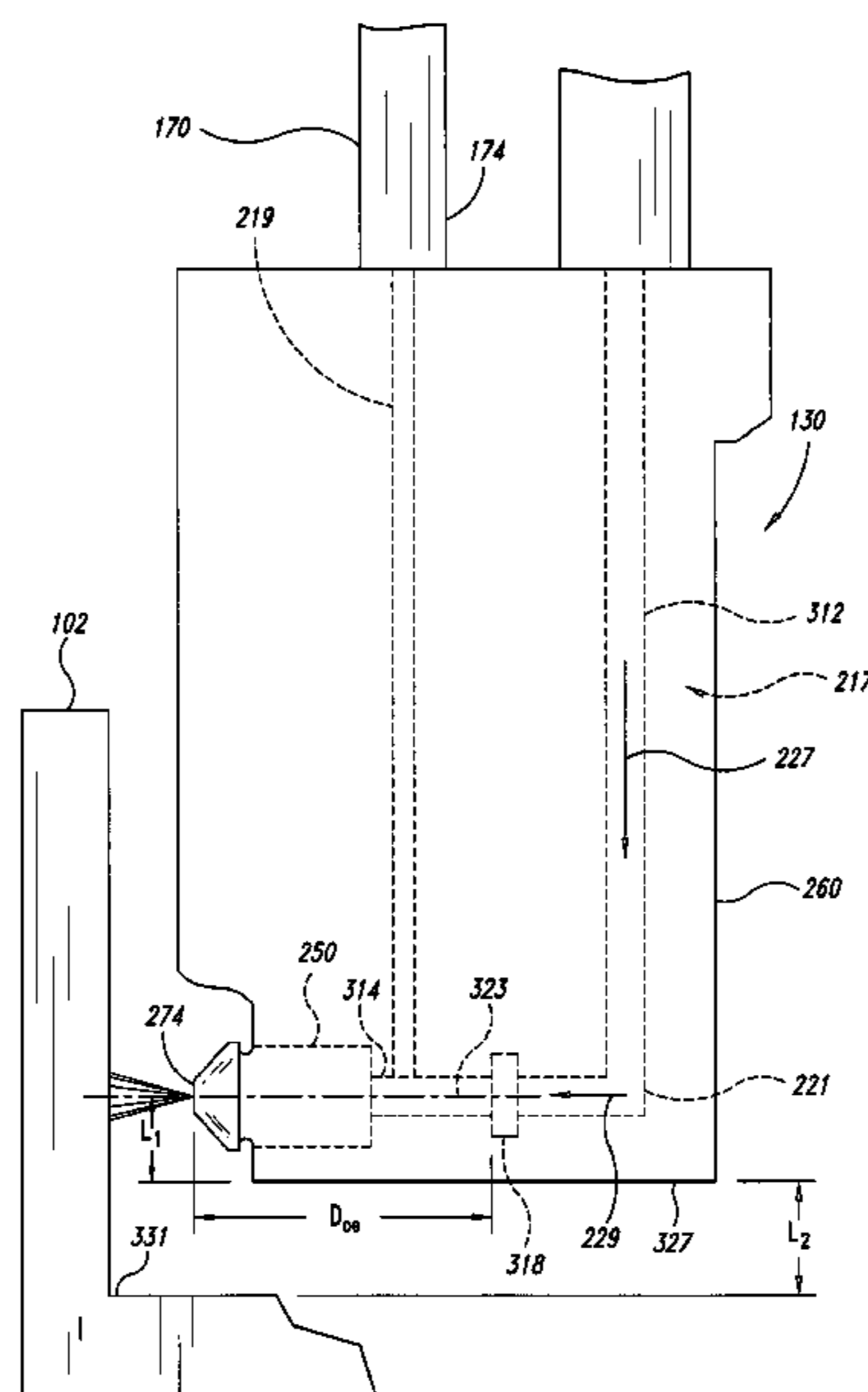

US 8,448,880 B2

Page 2

U.S. PATENT DOCUMENTS

6,939,205 B2 9/2005 Hopf et al.
6,945,859 B2 9/2005 Hashish et al.
7,341,504 B1 * 3/2008 Chen 451/90
2004/0107810 A1 6/2004 Sciulli et al.
2007/0165060 A1 * 7/2007 Helmig et al. 347/20

FOREIGN PATENT DOCUMENTS

EP 0248638 A2 12/1987
JP 63-154156 U 10/1988

JP 02-059267 A 2/1990
JP 04-372399 12/1992
JP 06-328365 11/1994
JP 07-171799 A 7/1995
WO 0044292 A1 8/2000
WO 00/56466 A2 9/2000
WO 03011524 A1 2/2003

* cited by examiner

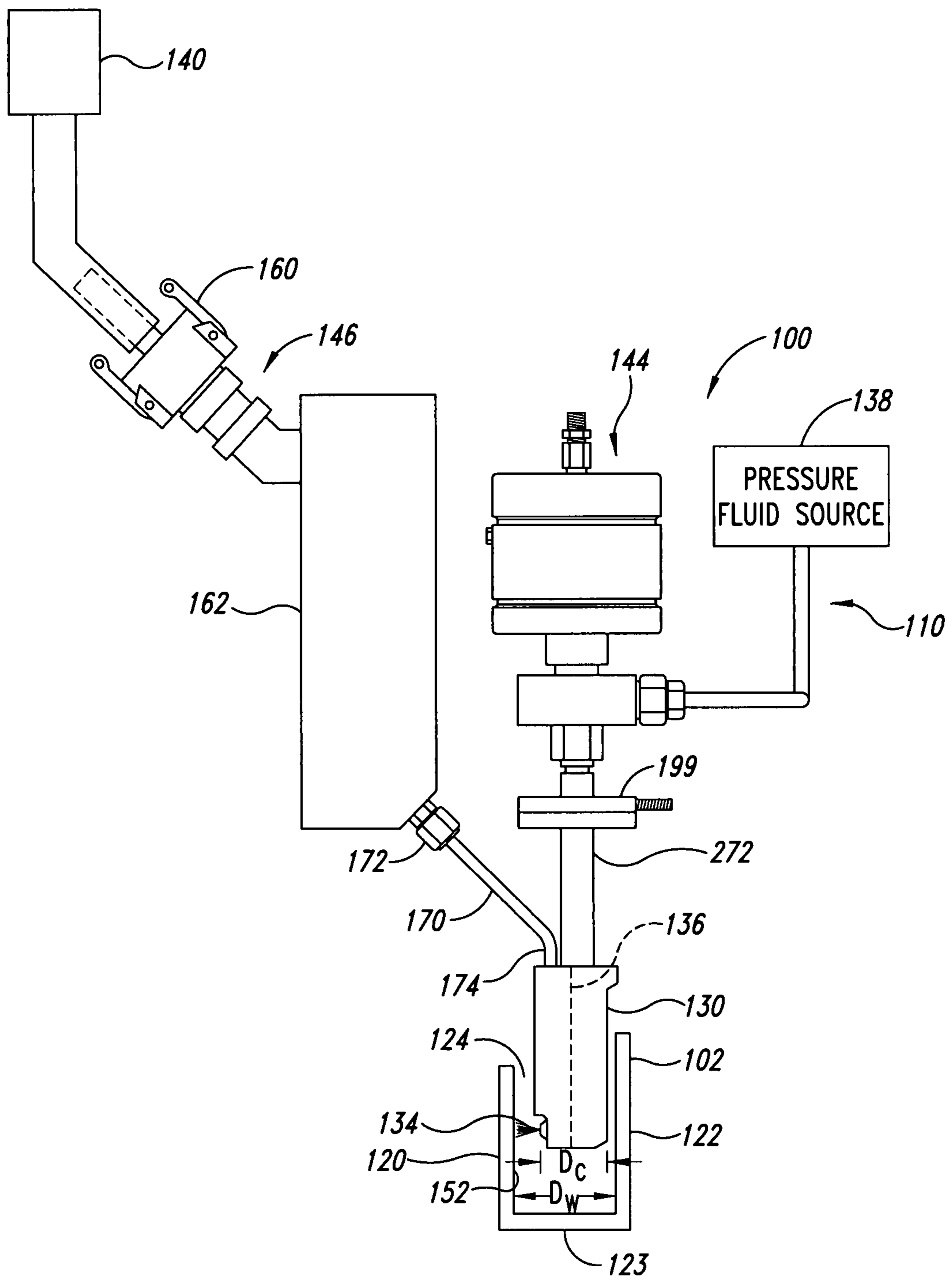

FIG. 1

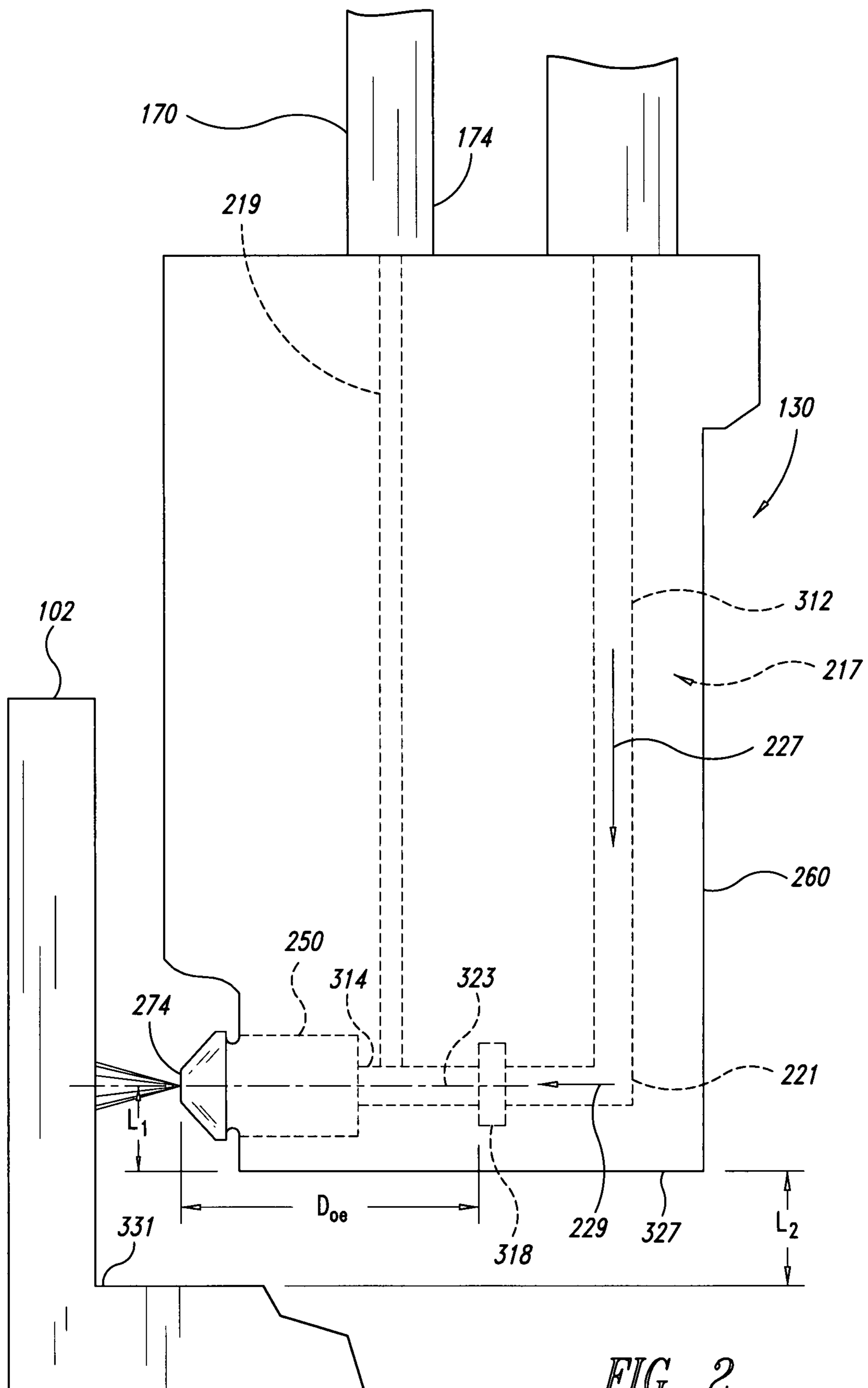
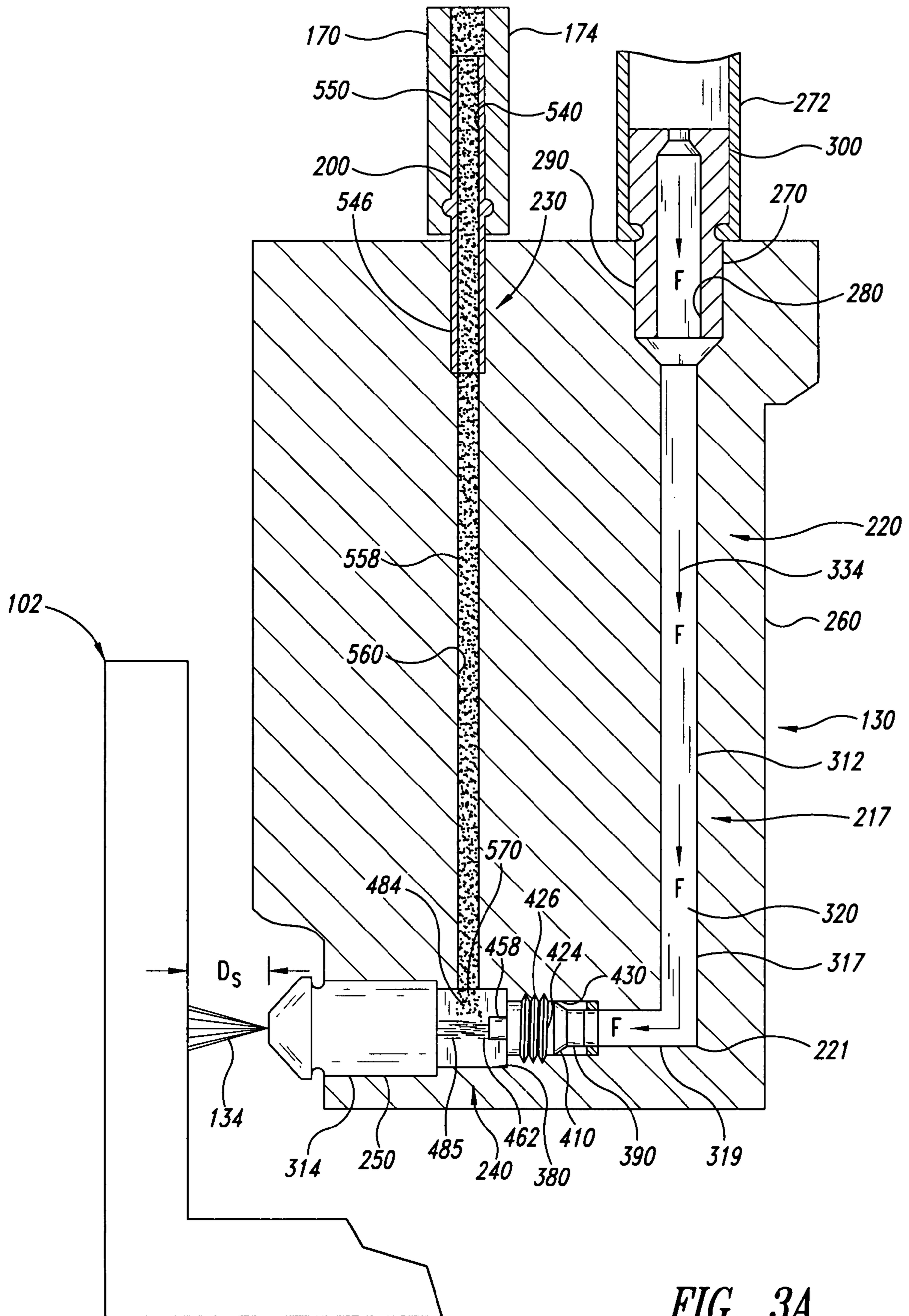

FIG. 2



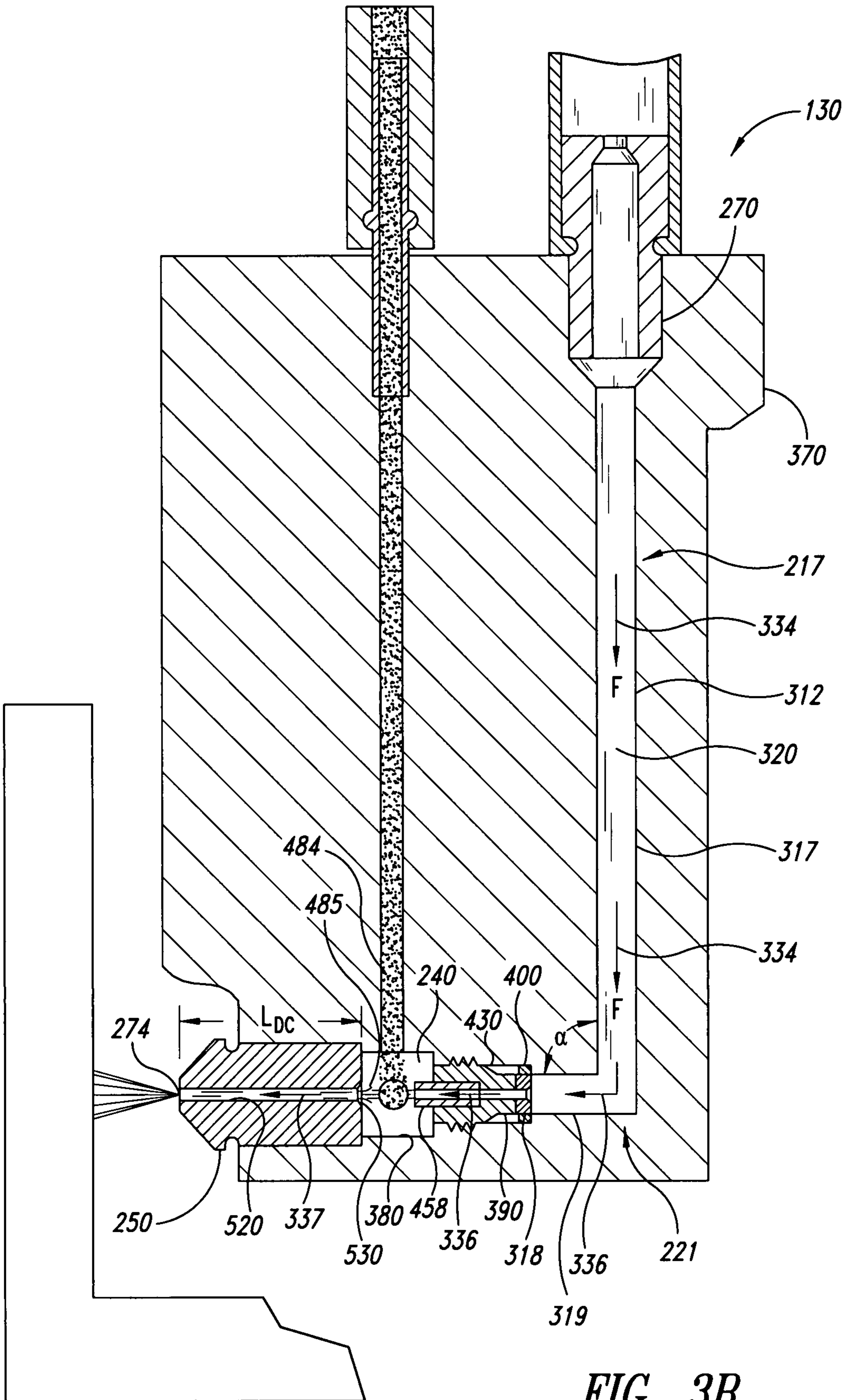

FIG. 3B

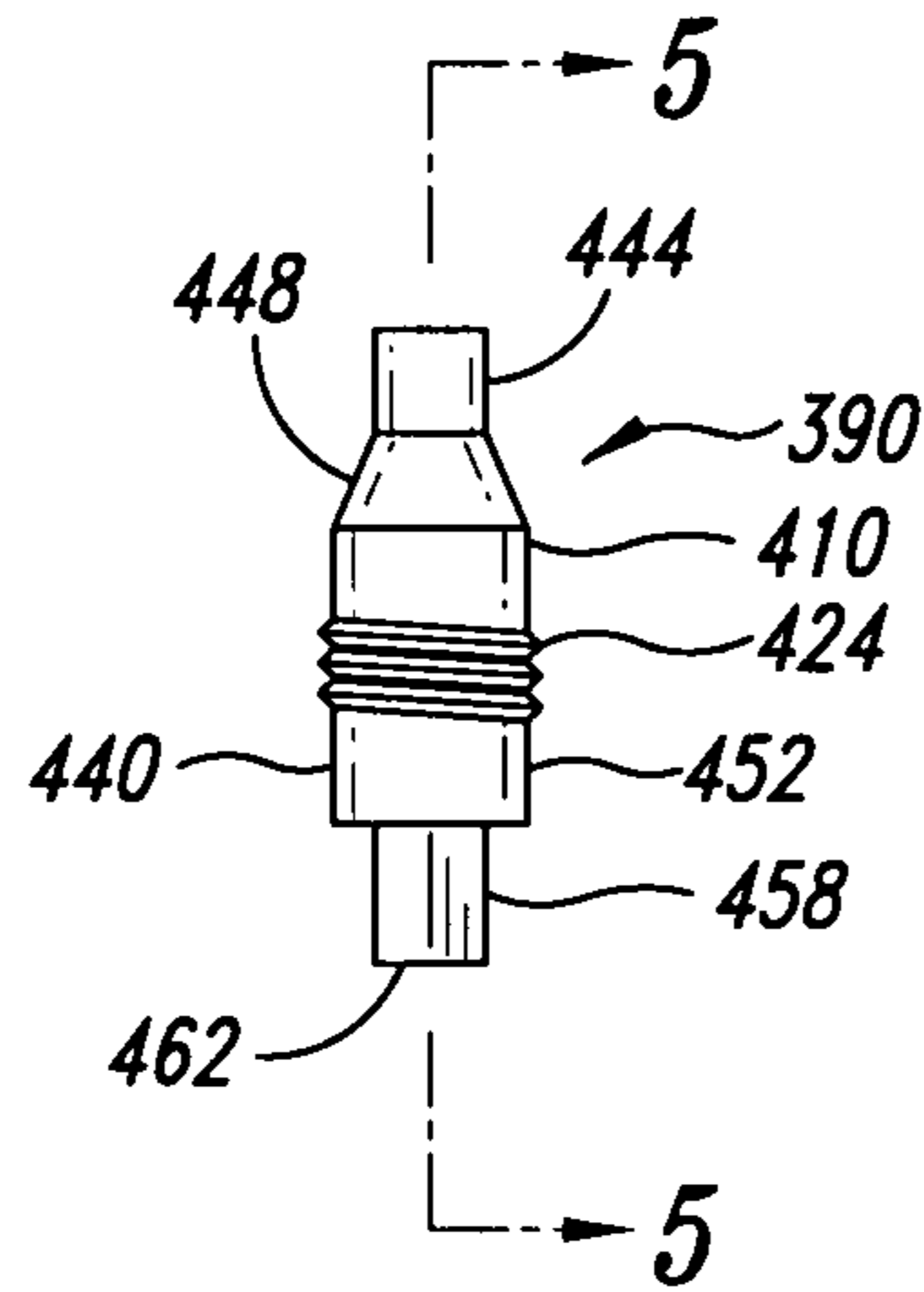

FIG. 4

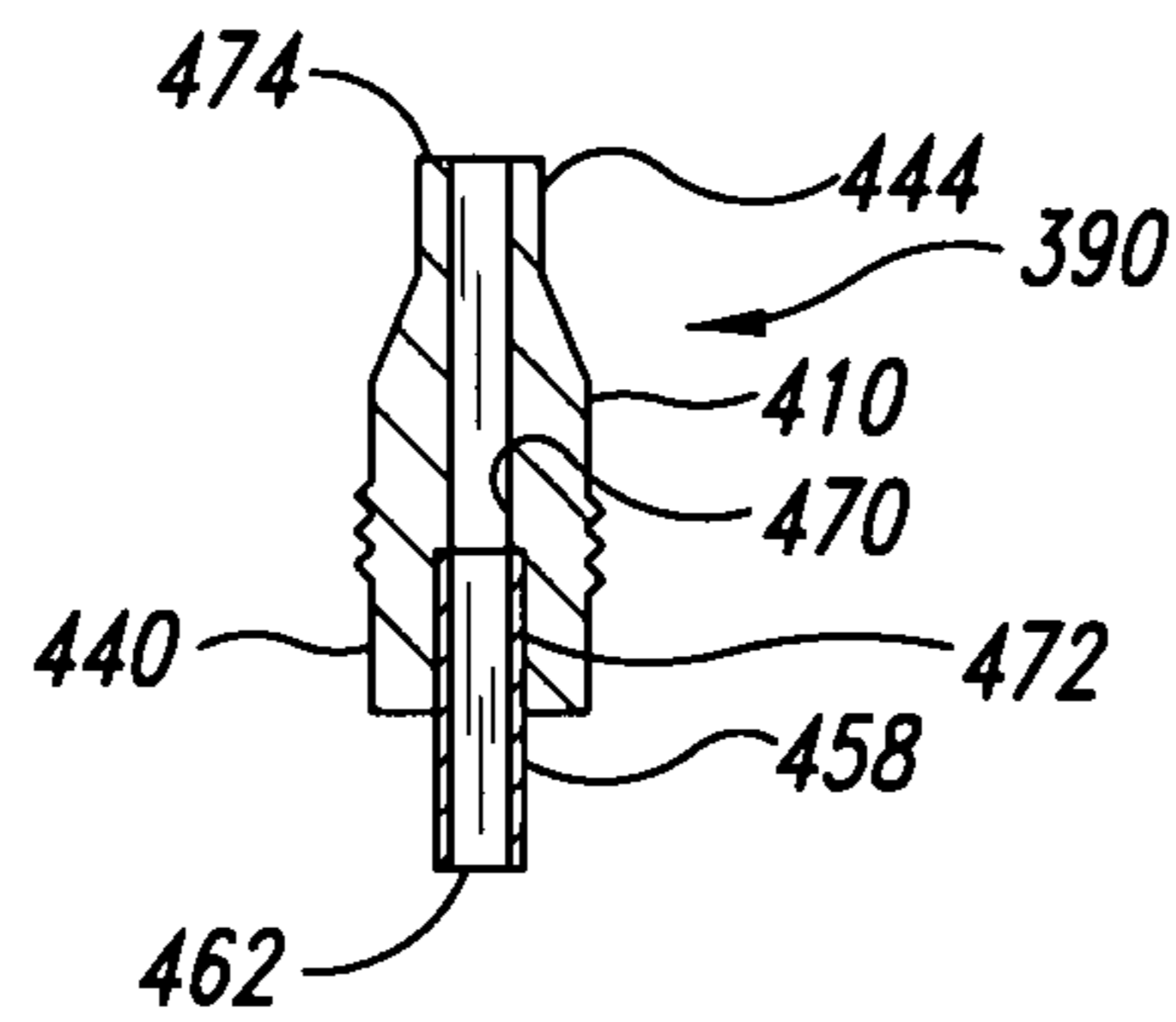

FIG. 5

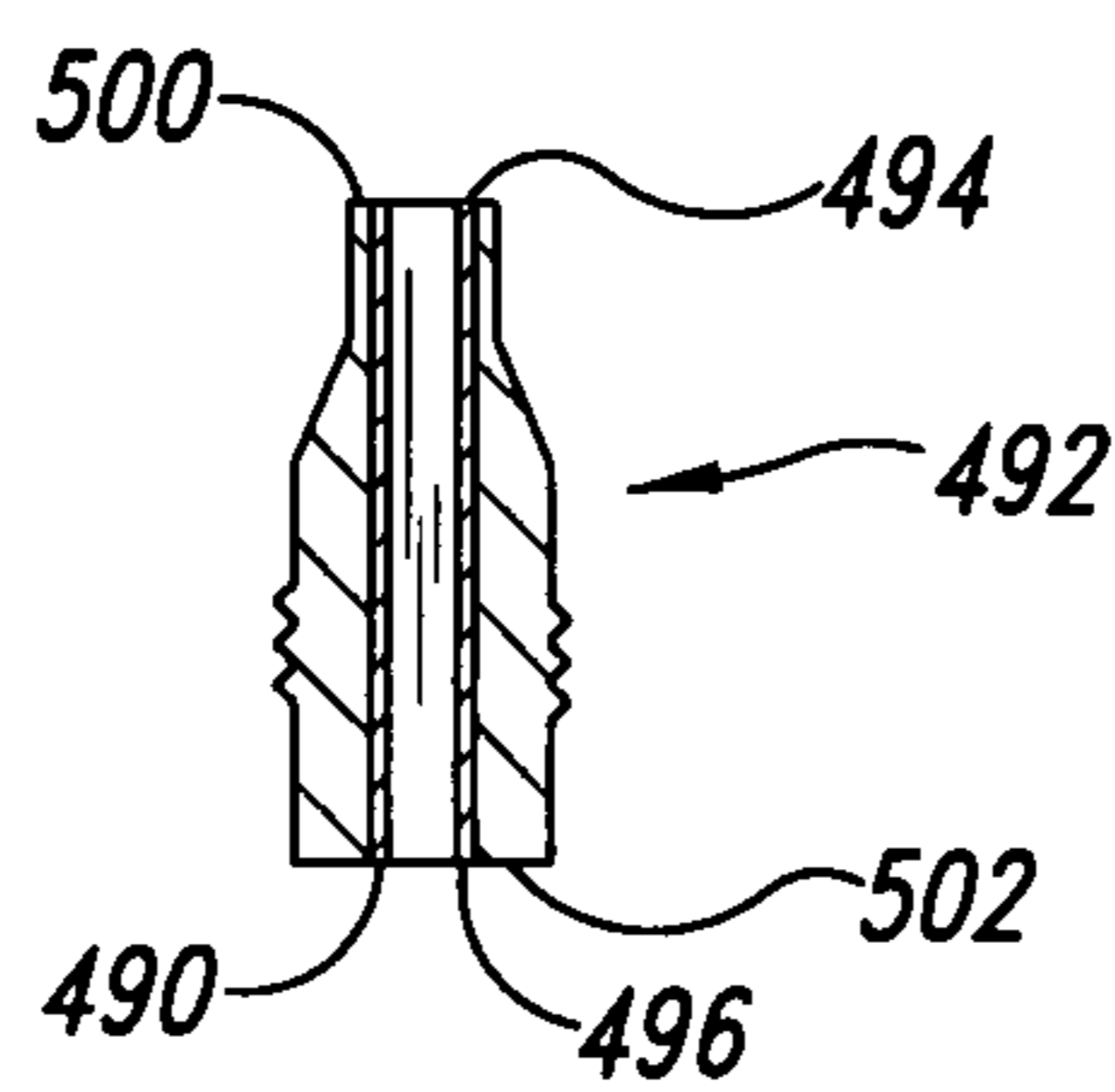

FIG. 6

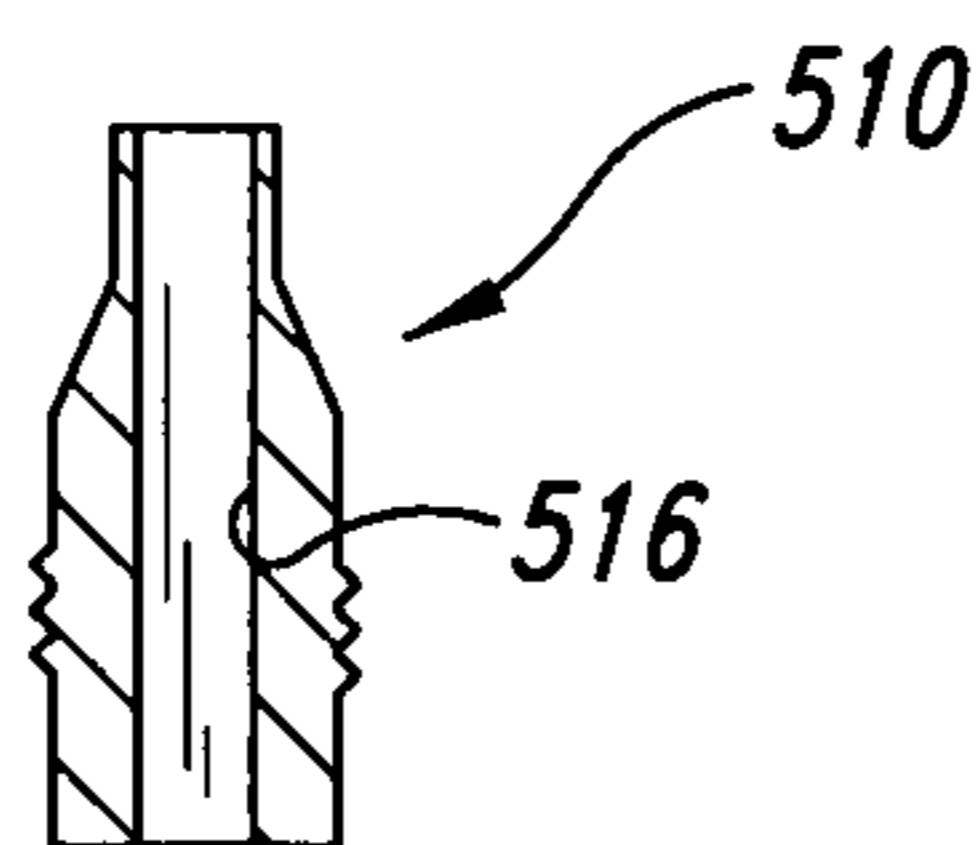

FIG. 7

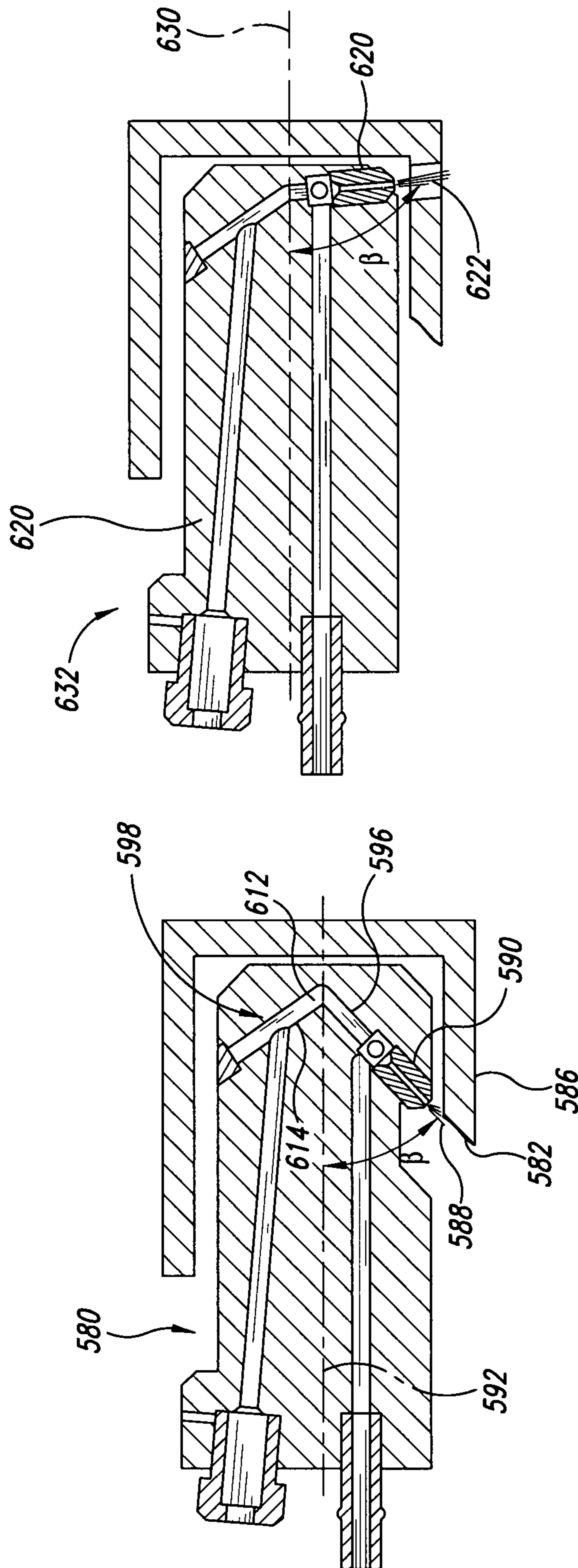
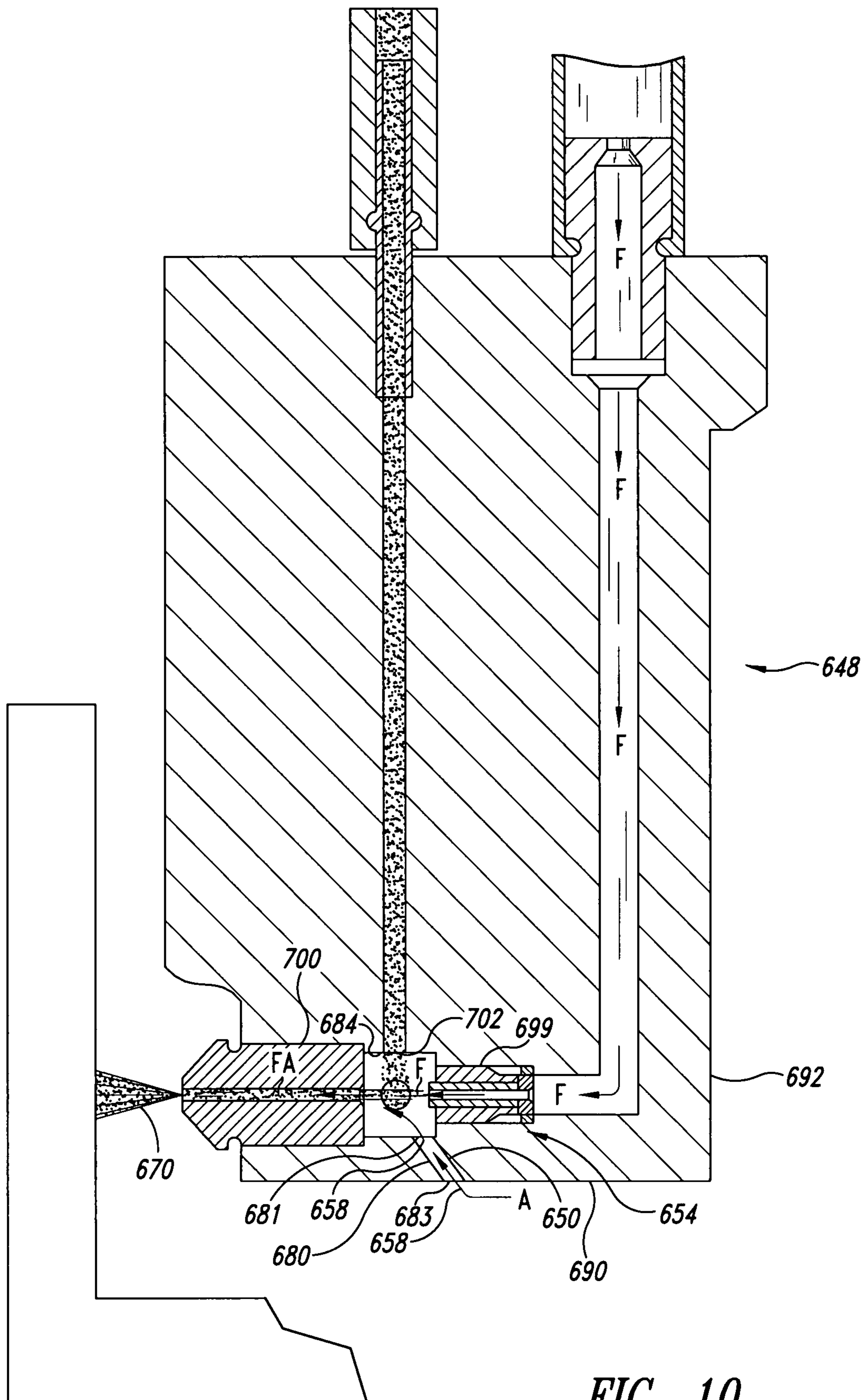

FIG. 9

FIG. 8



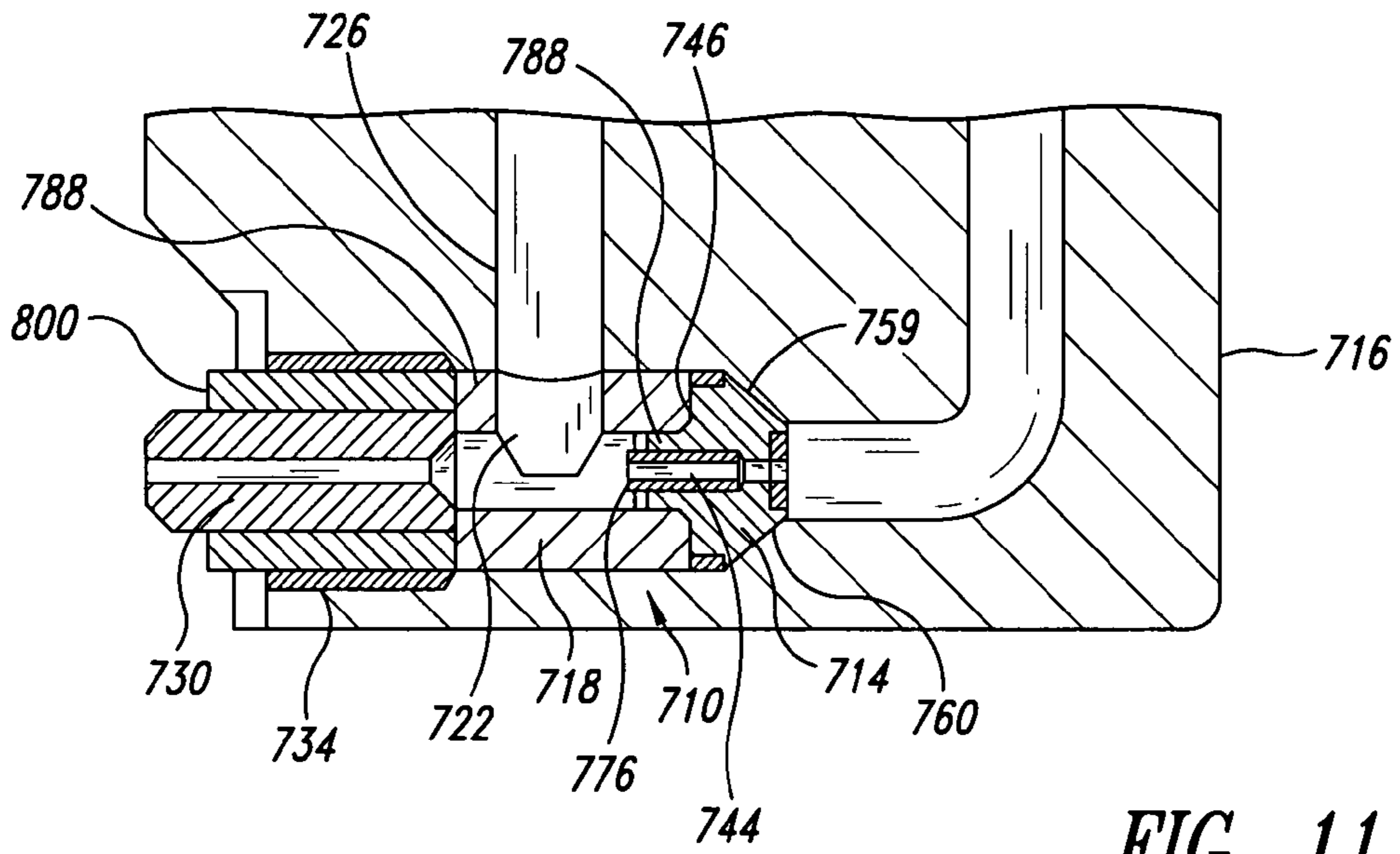

FIG. 11

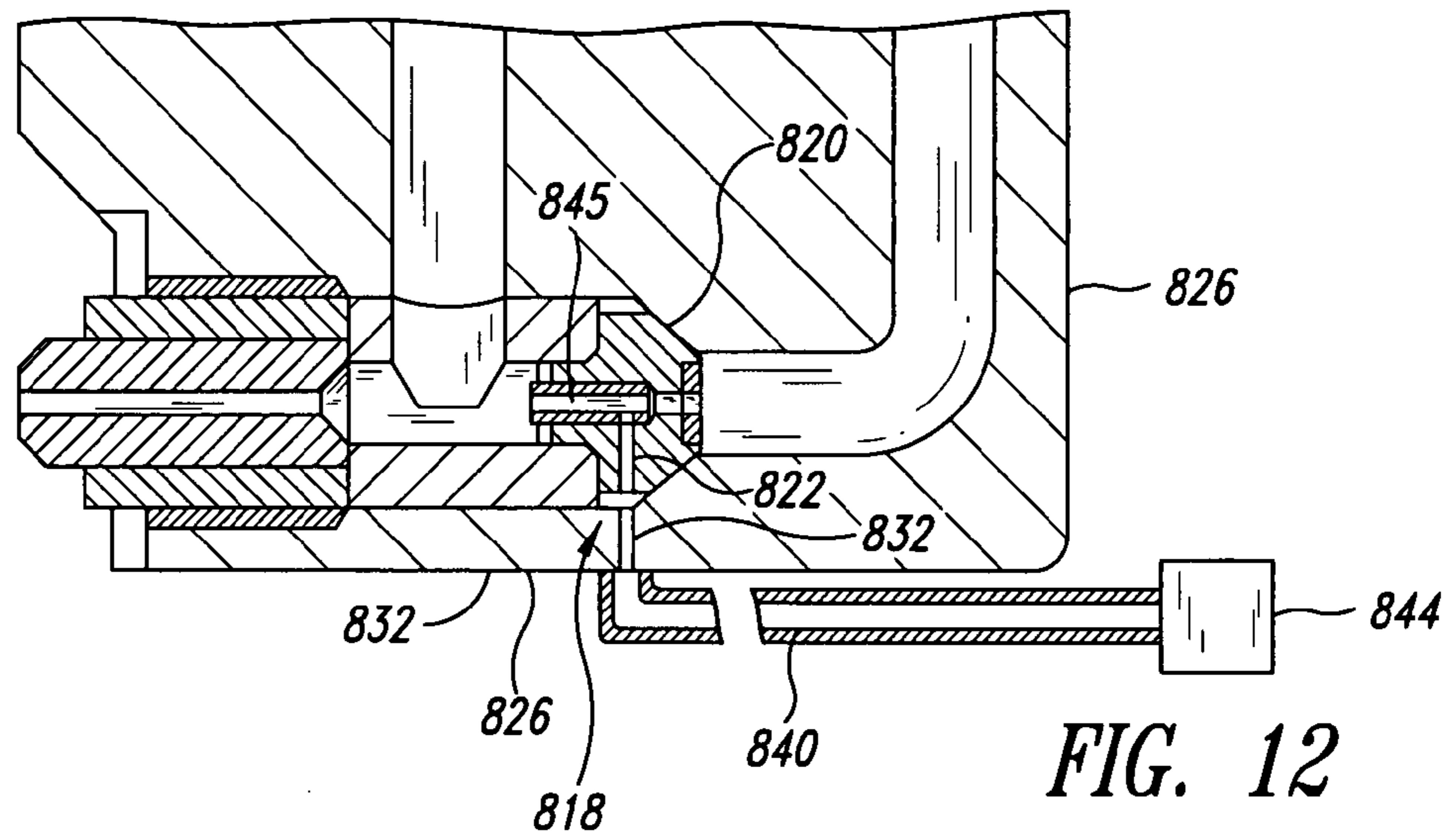

FIG. 12

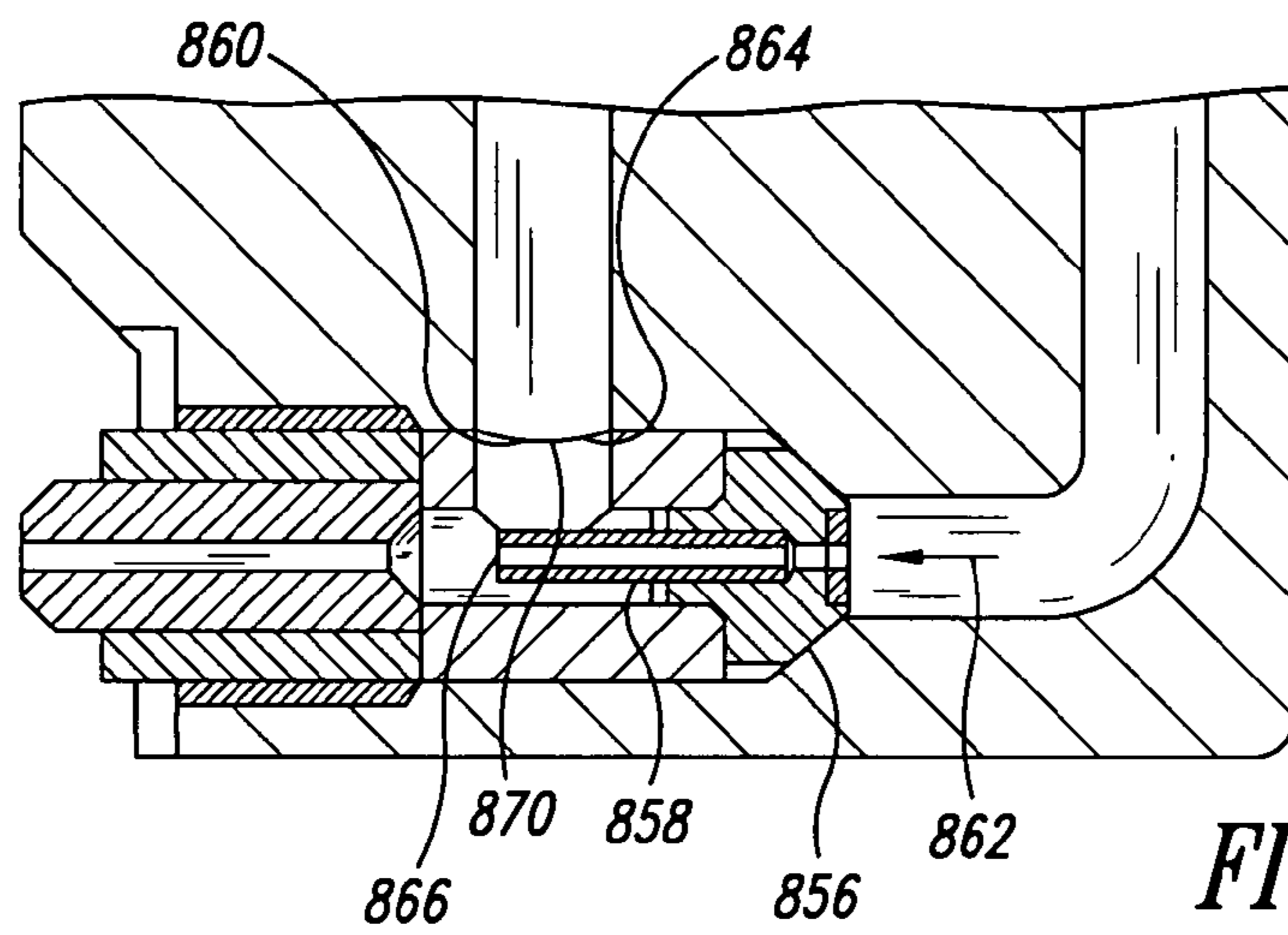

FIG. 13

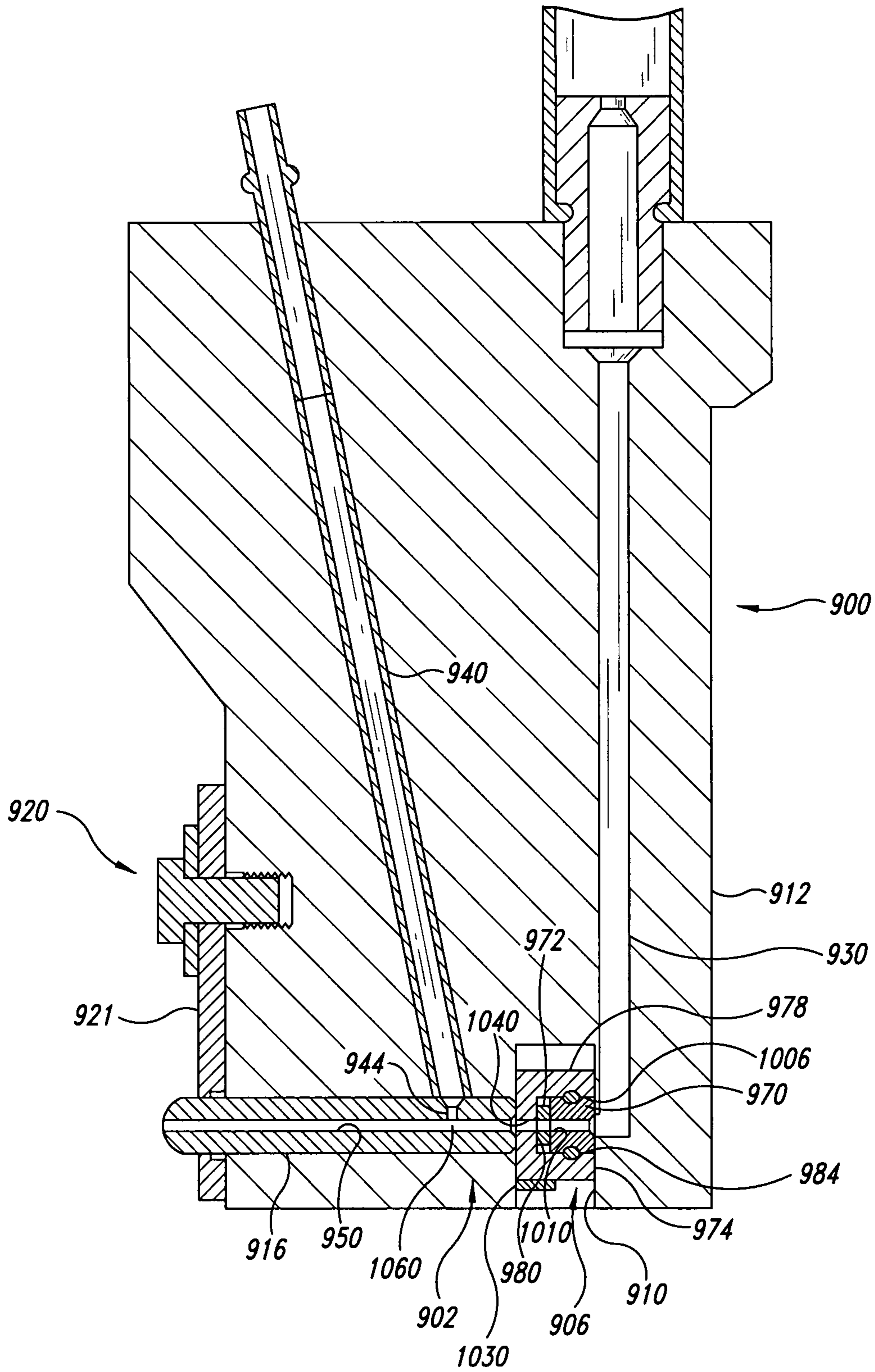

FIG. 14

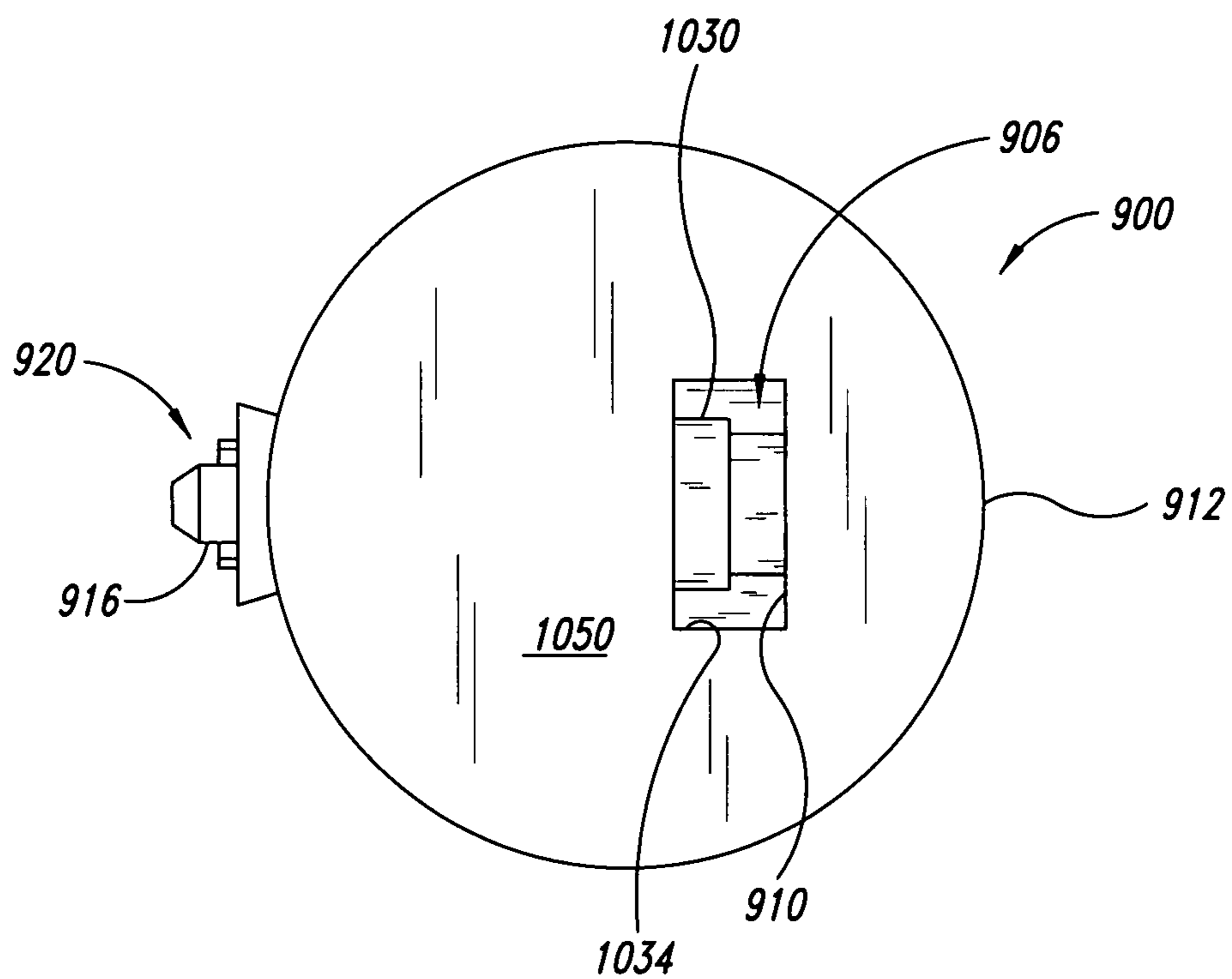
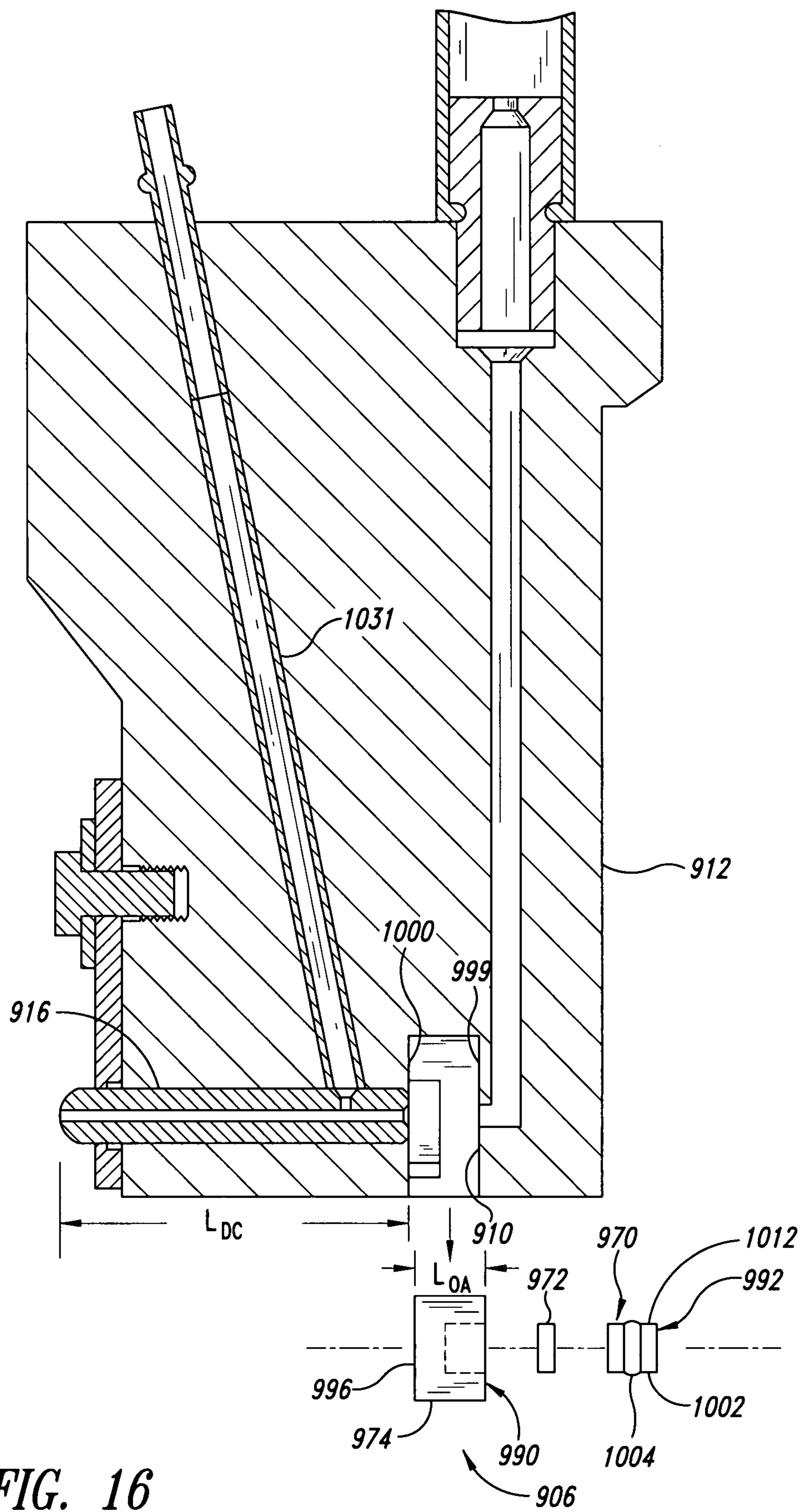

FIG. 15



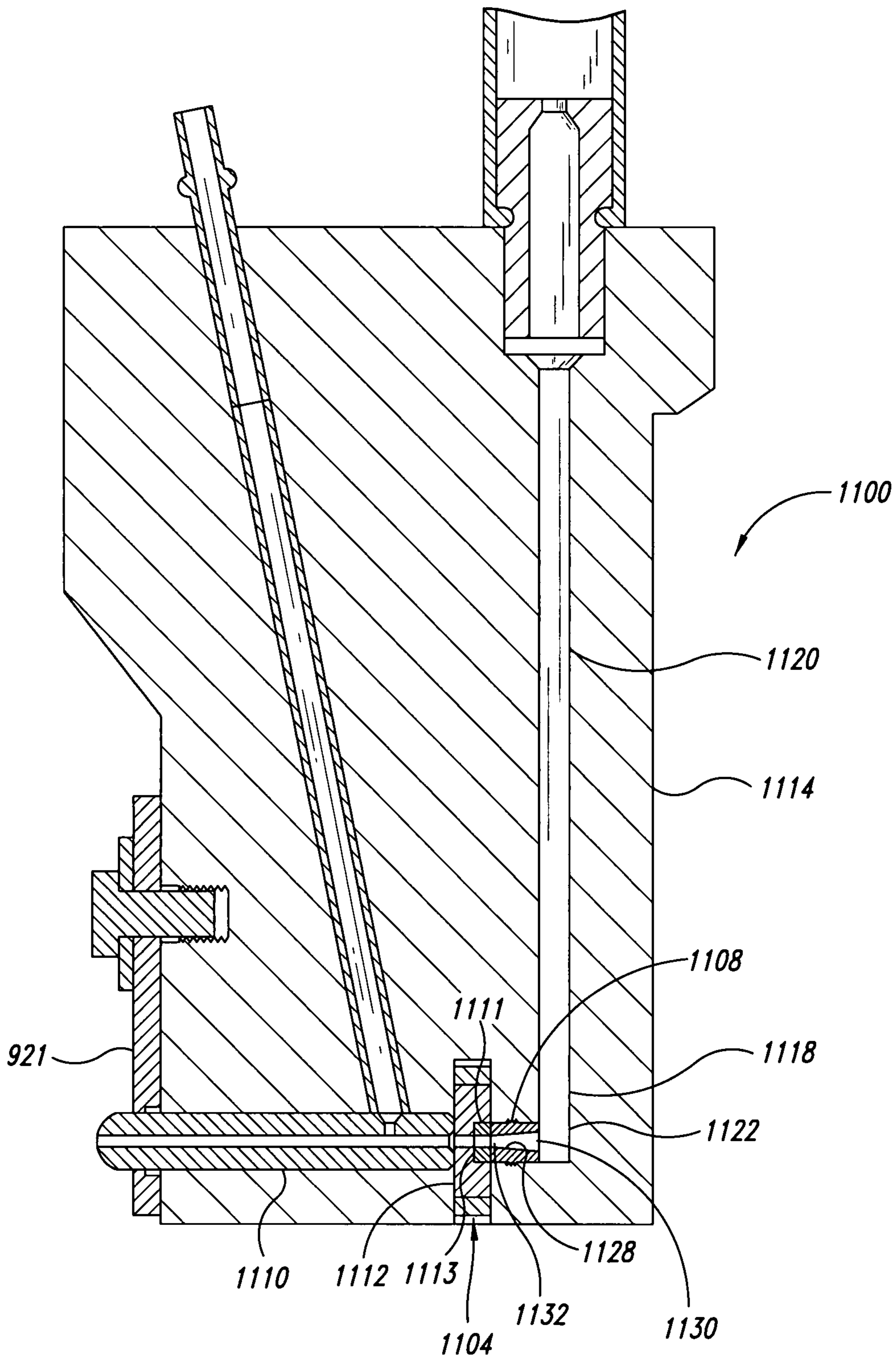

FIG. 17

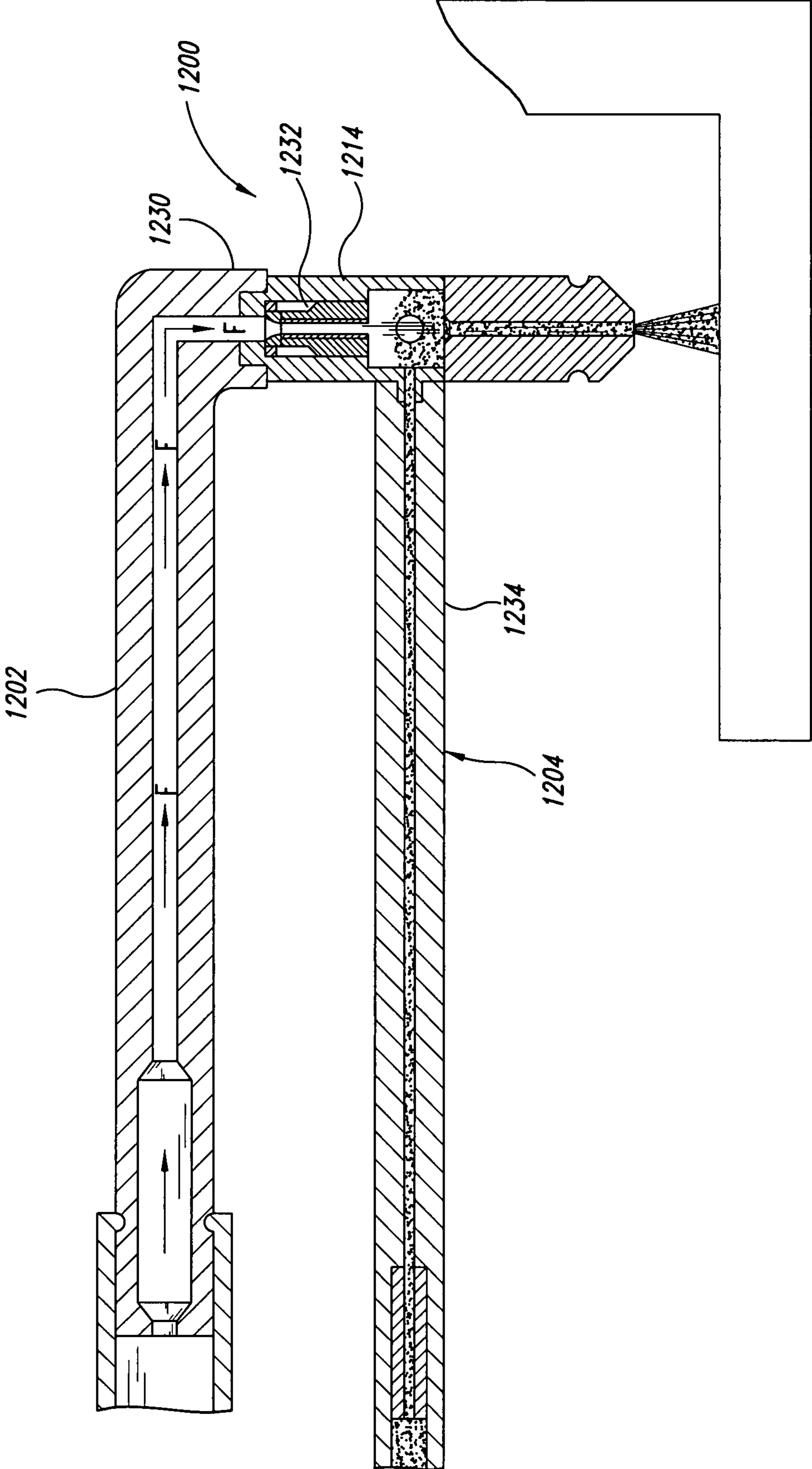

FIG. 18

1

**APPARATUS AND PROCESS FOR
FORMATION OF Laterally Directed
FLUID JETS**

BACKGROUND OF THE INVENTION

1. Field of the Invention

The present invention relates generally to processes and apparatuses for generating fluid jets, and in particular, processes and apparatuses for generating laterally directed high-pressure fluid jets.

2. Description of the Related Art

Conventional fluid jet systems have been used to clean, cut, or otherwise process workpieces by pressurizing fluid and then delivering the pressurized fluid against workpieces. Fluid jet systems often have straight nozzle systems that require significant operating clearance around the target workpiece and, consequently, may be unsuitable for processing workpieces in remote locations or within confined spaces.

For example, nozzle systems are often slender and have large axial lengths rendering them unsuitable for processing many types of workpieces. A conventional nozzle system may have a long straight feed tube, a cutting head and a long straight mixing tube aligned with and downstream of the feed tube. A jewel orifice may be positioned between the feed tube and the mixing tube within the cutting head. During processing, fluid flows along an extremely long linear path extending through the linearly arranged feed tube, orifice, and mixing tube.

Fluid jets can be used to process various types of workpieces, such as aircraft components. Unfortunately, numerous locations of aircraft components may provide minimal amounts of clearance. It may be difficult or impossible to adequately process these areas due to the large overall axial length of conventional fluid jet nozzle systems. For example, aircraft stringers may have flanges about 1.5 inches from one another. Conventional nozzles have axial lengths that are greater than 1.5 inches and, consequently, are unsuitable for use in such tight spaces. Other types of workpieces may likewise have features that cannot be adequately accessed with traditional fluid jet systems.

The present disclosure is directed to overcome one or more of the shortcomings set forth above, and/or provide further unrelated or related advantages.

BRIEF SUMMARY OF THE INVENTION

Some embodiments disclosed herein include the development of a fluid jet delivery system having a nozzle system dimensioned to fit into relatively small spaces. For example, a low-profile nozzle system of a fluid jet delivery system can be navigated through narrow spaces to access a target region, even remote interior regions of a workpiece. Low-profile nozzle systems can fit within various features including, without limitation, apertures, bores, channels, gaps, chambers, cavities, and the like, as well as other features that may provide access to a target site. During a single processing sequence, the nozzle system can pass through any number of features with varying sizes and geometries.

Nozzle systems disclosed herein can output a fluid jet at an orientation based on one or more processing criteria, such as a desired stand-off distance. Different nozzle systems can output fluid jets at different orientations. Even though two nozzle systems may have the same or similar outer dimensions, the two nozzle systems can deliver fluid jets at different orientations.

2

The nozzle systems in some embodiments can output a fluid jet in a lateral direction with respect to a direction of travel of the feed fluid flow. Because the fluid jet is directed laterally outward, the nozzle system can be inserted into and operated within relatively small spaces. The fluid flow within the nozzle system can be redirected one or more times in order to reduce selected dimensions of the nozzle system. In some embodiments, the fluid flow upstream of a nozzle orifice is redirected one time using, for example, an angled conduit.

In some embodiments, a primary direction of travel of the feed fluid flow upstream of the nozzle orifice is not aligned with respect to a secondary direction of travel of the fluid flow downstream of the orifice. In some embodiments, for example, the sum of the vectors of the flow velocity of the fluid jet exiting the nozzle orifice is not aligned with the sum of the vectors of the flow velocity of the fluid flow in a feed fluid conduit that is upstream of the nozzle orifice.

In some embodiments, nozzle systems can include one or more secondary flow ports positioned at various locations along a flow path in the nozzle system. Fluids (e.g., water, saline, air, gases, and the like), media, etchants, and other substances suitable for delivery via the nozzle system can be delivered through the secondary flow ports so as to alter one or more desired flow criteria, including, without limitation, coherency of the fluid jet, dispersion of the fluid jet, proportions of the constituents of the fluid jet (either by weight or by volume), flow turbulence, spreading of the fluid jet, or other flow characteristics, as well as other flow parameters related to the performance of fluid jets. The secondary flow ports can be oriented perpendicularly or obliquely with respect to the direction of flow of the fluid passing through the conduit into which the secondary flow ports feed.

In some embodiments, a fluid jet delivery system for generating a high-pressure abrasive fluid jet comprises a media delivery system configured to output abrasive media, a fluid delivery system configured to output fluid, and a nozzle system. The nozzle system includes a media inlet in fluid communication with the media delivery system, a fluid inlet in fluid communication with the fluid delivery system, a nozzle orifice in fluid communication with the fluid inlet and configured to generate a fluid jet using fluid flowing through the fluid inlet, and a delivery conduit through which the fluid jet generated by the nozzle orifice passes. The delivery conduit comprises an outlet through which the fluid jet exits the nozzle system. The nozzle system further comprises a fluid flow conduit and a media flow conduit. The fluid flow conduit extends between the fluid inlet and the outlet of the delivery conduit. The fluid flow conduit has an upstream section and a downstream section. The nozzle orifice is interposed between the upstream and downstream sections such that fluid in the upstream section passes through the nozzle orifice to generate the fluid jet in the downstream section. The upstream section comprises a flow redirector that receives fluid flow traveling in a first direction and outputs the fluid flow in a second direction towards the nozzle orifice. The first direction is substantially different than the second direction. The media flow conduit extends between the media inlet and the downstream section of the fluid flow conduit such that abrasive media passing through the media conduit is mixed with the fluid jet, generated by the nozzle orifice, passing along the downstream section of the fluid flow conduit.

In some other embodiments, a fluid jet delivery system for producing a high-pressure abrasive fluid jet comprises a nozzle system for generating a high-pressure abrasive fluid jet. The nozzle system comprises a fluid feed conduit, nozzle orifice, a media feed conduit, and an outlet. The fluid feed conduit includes a first section, a second section, and a flow

redirector between the first and second sections. The flow redirector is configured to receive a fluid flow traveling in a first direction through the first section and to direct the fluid flow in a second direction angled with respect to the first direction. The nozzle orifice is downstream of the second section of the fluid feed conduit and configured to generate a fluid jet. Abrasive is delivered through the media feed conduit into a fluid jet generated by the nozzle orifice so as to form a high-pressure abrasive media fluid jet. The high-pressure abrasive media fluid jet exits the nozzle system via the outlet.

In some embodiments, a method for producing a high-pressure abrasive water jet with a nozzle system is provided. The method comprises passing a fluid flow through an upstream section of a feed fluid conduit of the nozzle system. The fluid flow is passed through an angled section of the feed fluid conduit such that the fluid flow delivered out of the angled section is traveling in a different direction than the fluid flow upstream of the angled section. The fluid flow is also passed through a nozzle orifice. The nozzle orifice is positioned downstream of the angled section of the feed fluid conduit. A flow of abrasive media is delivered towards the fluid flow exiting the nozzle orifice so as to form a high-pressure abrasive water jet.

BRIEF DESCRIPTION OF THE SEVERAL VIEWS OF THE DRAWINGS

In the drawings, identical reference numbers identify similar elements or acts. The sizes and relative positions of elements in the drawings are not necessarily drawn to scale. For example, the shapes of various elements and angles may not be drawn to scale, and some of these elements may be arbitrarily enlarged and positioned to improve drawing legibility.

FIG. 1 is an elevational view of a fluid jet delivery system processing a workpiece, in accordance with one illustrated embodiment.

FIG. 2 is a side elevational view of a low-profile nozzle system, wherein some internal components of the nozzle system are in phantom line.

FIG. 3A is a partial cross-sectional view of a low-profile nozzle system for a fluid jet delivery system, in accordance with one embodiment.

FIG. 3B is a cross-sectional view of the low-profile nozzle system of FIG. 3A.

FIG. 4 is a side elevational view of an orifice mount, in accordance with one embodiment.

FIG. 5 is a cross-sectional view of the orifice mount of FIG. 4 taken along the line 5-5 of FIG. 4.

FIG. 6 is a cross-sectional view of an orifice mount, in accordance with one embodiment.

FIG. 7 is a cross-sectional view of an orifice mount, in accordance with one embodiment.

FIG. 8 is a cross-sectional view of a nozzle system generating a laterally directed fluid jet processing a workpiece, in accordance with one embodiment.

FIG. 9 is a cross-sectional view of a nozzle system generating a laterally directed fluid jet processing a workpiece, in accordance with another embodiment.

FIG. 10 is a cross-sectional view of a nozzle system with a secondary port for a mixing chamber, in accordance with one embodiment.

FIGS. 11-13 are cross-sectional views of portions of nozzle systems, in accordance with some embodiments.

FIG. 14 is a cross-sectional view of a nozzle system having a removable orifice assembly, in accordance with one embodiment.

FIG. 15 is a bottom view of the nozzle system of FIG. 14.

FIG. 16 is a cross-sectional view of a nozzle main body and an exploded view of an orifice assembly removed from the nozzle main body.

FIG. 17 is a cross-sectional view of a nozzle system having a removable orifice assembly, in accordance with one embodiment.

FIG. 18 is a cross-sectional view of a modular nozzle system, in accordance with one embodiment.

DETAILED DESCRIPTION OF THE INVENTION

The following description relates to processes and systems for generating and delivering fluid jets suitable for cleaning, abrading, cutting, milling, or otherwise processing workpieces. The fluid jets can be used to conveniently process a wide range of features having different shapes, sizes, and access paths. For example, a fluid jet delivery system can have a nozzle system for delivery through deep or narrow openings, channels, or holes, as well as other difficult to access locations, in addition to easily accessible locations (e.g., an exterior surface of a workpiece). Fluid jet delivery systems with low-profile nozzle systems are disclosed in the context of processing regions of workpieces with minimal clearances because they have particular utility in this context. For example, low-profile nozzle systems can be navigated into and through relatively small spaces in order to access and then process remote interior regions of the workpiece.

Unless the context requires otherwise, throughout the specification and claims which follow, the word “comprise” and variations thereof, such as, “comprises” and “comprising” are to be construed in an open, inclusive sense, that is as “including, but not limited to.”

As used in this specification and the appended claims, the singular forms “a,” “an,” and “the” include plural referents unless the context clearly dictates otherwise. Thus, for example, reference to a nozzle system including “a port” includes a single port, or two or more ports. It should also be noted that the term “or” is generally employed in its sense including “and/or” unless the context clearly dictates otherwise.

FIG. 1 shows a fluid jet delivery system 100 for processing a workpiece 102, illustrated as a generally U-shaped member with opposing sidewalls 120, 122 that define a somewhat narrow channel 124. Generally, the fluid jet delivery system 100 includes a low-profile nozzle system 130 configured to generate a fluid jet 134 capable of processing a wide range of materials. The fluid jet 134 can be oriented at a selected angle with respect to the direction of travel of the fluid flow in the nozzle system upstream of the nozzle orifice and/or the direction of motion of the nozzle system.

The illustrated fluid jet 134 is aimed in a direction that is not aligned with respect to a longitudinal axis 136 of the nozzle system 130, thereby reducing the operating clearance of the nozzle system 130 as compared to operating clearance of conventional nozzles. The nozzle system 130 can have a relative small dimension D_c to reduce the clearance necessary to process the workpiece 102 and, in some embodiments, also to reduce a distance between a rearward portion of the nozzle system 130 and the surface 152 being processed. The dimension D_c can be smaller than a longitudinal length of a linearly arranged conventional nozzle. As used herein, and as discussed below, the term “fluid jet” may refer to a jet comprising only fluid (or mixture of fluids) or a media fluid jet comprising both fluid and media. A fluid jet comprising only fluid may be well suited for effectively cleaning or texturing a substrate. A media fluid jet can include media (e.g., abrasive particles) entrained in various types of fluids, as detailed

5

further below. A media fluid jet comprising media in the form of abrasive may be generally referred to as an abrasive fluid jet.

The fluid jet delivery system **100** can include a pressure fluid source **138** configured to pressurize a fluid used to produce the fluid jet **134** and a media source **140** configured to provide media. In some embodiments, including the illustrated embodiment of FIG. 1, pressurized fluid from the pressure fluid source **138** flows through a fluid delivery system **144** and into the nozzle system **130**. Media from the media source **140** flows through a media delivery system **146** and into the nozzle system **130**. The nozzle system **130** combines the media and fluid and then generates the outwardly directed fluid jet **134** in the form of an abrasive fluid jet (illustrated in a generally horizontal orientation).

Although the illustrated nozzle system **130** is positioned between the sidewalls **120**, **122** and extends vertically, the nozzle system can be at other orientations. The media delivery system **146**, the fluid delivery system **144**, and the nozzle system **130** can cooperate to generate fluid jets at various orientations, and can also achieve a wide range of flow parameters of the fluid jet, including, without limitation, volumetric flow rate, flow velocity, level of homogeneity of the fluid jet **134**, composition of the fluid jet **134** (e.g., ratio of media to pressurized fluid), and combinations thereof.

Various types of workpieces can be processed with the fluid jet delivery system **100**. The illustrated workpiece **102** of FIG. 1 has the pair of spaced apart sidewalls **120**, **122** and a base **123** extending between the sidewalls **120**, **122**. The nozzle system **130** is positioned in the channel **124** having a relatively small width D_w . Such channels **124** are unsuitable for receiving traditional nozzle systems with heights greater than the width D_w . The nozzle system **130** can remain spaced from the sidewalls **120**, **122** while the fluid jet **134** is delivered against the surface **152** to be processed. Because the nozzle system **130** has a relatively small dimension D_c , the nozzle system **130** can be conveniently navigated through the channel **124** without contacting, and possible damaging or marring, one or both of the sidewalls **120**, **122**, even while maintaining desirable stand-off distances.

The workpiece **102** can be formed, in whole or in part, of one or more metals (e.g., steel, titanium, aluminum, and the like), composites (e.g., fiber reinforced composites, ceramic-metal composites, and the like), polymers, plastics, or ceramics, as well as other materials that can be processed with a fluid jet. The subsystems, subassemblies, components, and features of the fluid jet delivery system **100** discussed below can be modified or altered based on the configuration of the workpiece and features to be processed.

The orientation of the nozzle system **130** can be selected based on the access paths for reaching the target region. Accordingly, it will be appreciated that the nozzle system **130** can be in a variety of desired orientations, including generally vertically (illustrated in FIG. 1), generally horizontally (see, e.g., FIGS. 8, 9, and 18), or any orientation therebetween. Thus, the nozzle system **130** can be in a wide range of different positions during a processing routine.

The nozzle system **130** of FIG. 1 can be for ultrahigh-pressures, medium pressures, low pressures, or combinations thereof. Ultrahigh-pressure nozzle systems can operate at pressures equal to or greater than about 40,000 psi (276 MPa). Ultrahigh-pressure nozzles are especially well suited to cut or to mill hard materials (e.g., metals such as steel or aluminum). The illustrated workpiece **102** can comprise a hard material, which is rapidly cut with the ultrahigh fluid jet. Medium pressure nozzles can operate at a pressure in the range of about 15,000 psi (103 MPa) to about 40,000 psi (276 MPa).

6

Medium pressure nozzles operating at a pressure below 40,000 psi (276 MPa) are especially well suited to process soft materials, such as plastic materials. Low pressure nozzles can operate at a pressure lower than about 15,000 psi (103 MPa). The nozzle system **130** can also be used with fluid at other working pressures.

With continued reference to FIG. 1, the media source **140** can contain media in the form of an abrasive that is ultimately entrained in the fluid jet **134**. Although many different types of abrasives may be used, some embodiments use particles on the order of about 120 mesh or finer. For example, in some embodiments, the particles (e.g., garnet) are on the order of about 80 mesh or finer. The particular size of the abrasives can be selected based on the rate of abrasion, rate of cutting, desired surface texture, and the like. The abrasive can be dry or wet (e.g., a wet abrasive in a slurry form) depending on whether the fluid jet **134** abrades, textures, cuts, etch, polishes, cleans, or performs another procedure. The media source **140** can also have other types of media. For example, the media in the source **140** can be a fluid (e.g., liquid, gas, or mixture thereof) used to clean, polish, cut, etch, and the like. For example, the media can be an etching fluid or acid (e.g., hydrochloric acid, nitric acid, hydrofluoric acid, sulfuric acid, fluorosulfuric acid, and other fluids capable of removing material from the workpiece).

The illustrated media delivery system **146** extends from the media source **140** to the nozzle system **130** and, in one embodiment, includes an intermediate conduit **160** extending between the media source **140** and an optional air isolator **162**. As shown in FIGS. 1-3A, media feed line **170** has an upstream end **172** and a downstream end **174** coupled to the air isolator **162** and a media inlet **200** of the nozzle system **130** (FIG. 3A), respectively. Media from the media source **140** can pass through the intermediate conduit **160**, air isolator **162**, and feed line **170** and then into the media inlet **200**.

The media flow rate into the nozzle system **130** can be increased or decreased based on the manufacturing process. In some embodiments, the media is abrasive and the abrasive flow rate is equal to or less than about 7 lb/min (3.2 kg/min), 5 lb/min (2.3 kg/min), 1 lb/min (0.5 kg/min), or 0.5 lb/min (0.23 kg/min), or ranges encompassing such flow rates. In some embodiments, the abrasive flow rate is equal to or less than about 1 lb/min to produce the abrasive fluid jet **134** that is especially well suited for accurately processing targeted material with minimal impact to other untargeted material in proximity to the targeted material.

An actuation system can translate and/or rotate the nozzle system **130** as desired or needed. In some embodiments, including the illustrated embodiment of FIG. 1, an actuation system **199** is provided for selectively moving the nozzle assembly **130** with respect to the workpiece **102**. The actuation system **199** can be in the form of an X-Y-Z positioning table driven by a pair of drive mechanisms. The positioning table can have any number of degrees of freedom. Motors (e.g., stepper motors) can drive the table to control the movement of the nozzle system **130**. Other types of positioning systems employing linear slides, rail systems, motors, and the like can be used to selectively move and actuate the nozzle system **130** as needed or desired. U.S. Pat. No. 6,000,308, which is herein incorporated by reference in its entirety, discloses systems, components, and mechanisms that can be used to control the nozzle system **130**.

FIG. 2 shows the nozzle system **130** including a fluid flow conduit **217** and a media flow conduit **219**. As used herein, the term "conduit" is a broad term and includes, but is not limited to, a tube, hose, bore, channel, or other structure suitable for conveying a substance, such as fluid or media. A nozzle main

body 260 itself can define at least a portion of the fluid flow conduit 217. For example, material can be removed from the nozzle main body 260 to form a section of the fluid flow conduit 217 positioned upstream of an angled flow redirector 221. The illustrated fluid flow conduit 217 of FIG. 2 includes an L-shaped upstream section 312 and a downstream section 314. The upstream section 312 of the fluid flow conduit 217 can include the flow redirector 221 in the form of an elbow. FIGS. 2 and 3A show the fluid flow conduit 217 extending between the fluid inlet 270 and the mixing assembly 240.

The flow redirector 221 of FIGS. 2 and 3A is a non-linear section (e.g., an angled section) of the fluid flow conduit 217 formed via a bending process. In some embodiments, the flow redirector 221 is an angle elbow or other type of fixed or variable fitting. Thus, the flow redirector 221 and upstream and downstream sections 312, 314 can have a one-piece or multi-piece construction.

The flow redirector 221 of FIG. 2 can receive fluid passing through the upstream section 312 in a first direction (indicated by the arrow 227) and output the fluid in a second direction (indicated by the arrow 229) towards a nozzle orifice 318. The downstream section 314 extends between an outlet 274 and the nozzle orifice 318. The nozzle orifice 318 is positioned between the upstream and downstream sections 312, 314 such that fluid from the upstream section 312 passes through the nozzle orifice 318 to generate the fluid jet passing into the downstream section 314.

A distance D_{OE} between the nozzle orifice 318 and the outlet 274 can be selected based on the amount of clearance for processing the workpiece. The distance D_{OE} can be equal to or less than about 2 inches. In some embodiments, the distance D_{OE} can be equal to or less than about 1.5 inches. In some embodiments, the distance D_{OE} is in the range of about 1 inch to about 3 inches. In some embodiments, the distance D_{OE} is in the range of about 0.75 inch to about 2 inches. Other dimensions are also possible.

The nozzle orifice 318 of FIG. 2 has a centerline 323 near an outermost edge or surface 327 of the nozzle system 130. A length L_1 between the centerline 323 and the edge 327 can be minimized to increase processing flexibility. As such, a length L_2 from the centerline 323 to the workpiece 120 can be relatively small in order to access locations without much clearance. For increased processing flexibility, the length L_1 is less than about 0.5 inch (12.7 mm). In some embodiments, the length L_1 is less than about 0.15 inch (3.81 mm) to process relatively small features. In some embodiments, the length L_1 is about 0.1 inch (2.54 mm) such that the nozzle system 130 can conveniently process the corner 331 of the workpiece 102. In some embodiments, the length L_1 is greater than about 0.1 inch (2.54 mm) to process workpieces with more clearance. Other lengths L_1 are also possible. Various types of fluid components can form portions of the fluid flow conduit 217. FIG. 3A shows the downstream section 314 of the fluid flow conduit 217 including a mixing assembly 240 and a delivery conduit 250. The mixing assembly 240 of FIG. 3A is in communication with both a fluid feed assembly 220 and a media feed assembly 230. The delivery conduit 250 is positioned downstream of the mixing assembly 240 and is configured to generate the illustrated fluid jet 134.

In general, fluid flows through the fluid feed assembly 220 and into the mixing assembly 240. Media can pass through the media feed assembly 230 and into the mixing assembly 240 such that a selected amount of the media 484 is entrained in the fluid flow 485 passing through the mixing assembly 240. The fluid and entrained media then flow through the delivery conduit 250 thereby forming the fluid jet 134. The fluid feed assembly 220, media feed assembly 230, and mix-

ing assembly 240 are disposed in the main body or housing 260 of the nozzle assembly 130.

The fluid feed assembly 220 of FIG. 3A includes a fluid inlet 270 coupled to a fluid feed line 272 of the fluid delivery system 144. As used herein, the term "inlet" is a broad term that includes, without limitation, a feature that serves as an entrance. Exemplary inlets can include, but are not limited to, connectors (either threaded or unthreaded), bores (e.g., an internally threaded bore), passageways, and other types of components suitable for receiving a flowable substance. The illustrated fluid inlet 270 is a connector having a channel 280, a mounting portion 290 temporarily or permanently coupled to the nozzle main body 260, and a coupling portion 300 temporarily or permanently coupled to the fluid feed line 272.

Referring to FIGS. 3A and 3B, the upstream section 312 of the fluid flow conduit 217 includes a first section 317 extending upstream from the flow redirector 221 and a second section 319 extending downstream from the flow redirector 221. Generally, a substantial portion of the first section 317 extends primarily in a first direction (indicated by the arrows 334). The downstream second section 319 extends primarily in a second direction (indicated by the arrows 336) different than the first direction. The illustrated flow redirector 221 can guide fluid from the first section 317 to the second section 319, and thus reduce the working clearance needed to operate the nozzle system 130 in comparison to the working clearance required to operate linearly arranged conventional nozzle systems.

In some embodiments, including the illustrated embodiment of FIG. 3B, the flow redirector 221 defines an angle α between the first and second sections 317, 319. The illustrated angle α is about 90 degrees. The flow redirector can also define other angles α as discussed in connection with FIGS. 8 and 9. Additionally, the nozzle system 130 can have more than one flow redirector 221.

As best seen in FIG. 3B, the mixing assembly 240 includes the nozzle orifice 318 for producing a fluid jet, a mixing chamber 380, and an orifice mount 390 positioned between the nozzle orifice 318 and mixing chamber 380. The term "nozzle orifice" as used herein generally refers to, but is not limited to, a component or feature having an aperture or opening that produces a fluid jet suitable for processing a workpiece. Various types of jewels, fluid jet producing devices, or cutting stream producing devices can be used to achieve the desired flow characteristics of the fluid jet 134. In some embodiments, an orifice of the nozzle orifice 318 has a diameter in the range of about 0.001 inch (0.025 mm) to about 0.02 inch (0.5 mm). Nozzle orifices with orifices having other diameters can also be used, if needed or desired.

A sealing member 400 can form a fluid tight seal to reduce, limit, or substantially eliminate any fluid escaping to the mixing assembly 240. The illustrated sealing member 400 is a generally annular compressible member surrounding the nozzle orifice 318, thereby sealing the interface between the nozzle orifice 318 and the nozzle main body 260. Additionally, the sealing member 400 can help hold the nozzle orifice 318 in a desired position. Polymers, rubbers, metals, and combinations thereof can be used to form the sealing member 400.

The nozzle system 130 can employ various types of orifice mounts. FIGS. 4 and 5 show the orifice mount 390 including a mount main body 410 and a guide tube 458 protruding outwardly from the mount main body 410. The guide tube 458 can be temporarily or permanently coupled to the mount main body 410. For example, a press fit, interference fit, or shrink fit can be used to couple the guide tube 458 to the mount main body 410.

FIGS. 3A and 4 show the mount main body 410 including engagement features 424 for engaging complementary features 426 of the nozzle main body 260. The illustrated engagement features 424 are in the form of external threads that mate with internal threads 426. The engagement features 424, 426 cooperate to limit or substantially prevent axial movement of the mount main body 410 with respect to the nozzle main body 260, even when an ultra high-pressure fluid flow passes through the mixing assembly 240.

To remove and replace the nozzle orifice 318, the orifice mount 390 can be conveniently twisted to move it axially out of a receiving cavity 430 of the nozzle main body 260. After the nozzle orifice 318 is removed, another nozzle orifice can be installed. The nozzle orifice 318 can thus be replaced any number of times during the working life of the nozzle system 130.

With continued reference to FIGS. 4 and 5, the mount main body 410 includes an enlarged portion 440 for engaging the nozzle main body 260, a seating portion 444 for holding the nozzle orifice 318 in a desired position, and a tapered portion 448 extending between the enlarged portion 440 and the seating portion 444. The enlarged portion 440 has an outer perimeter that is greater than the outer perimeter of the seating portion 444. The tapered portion 448 has an outer perimeter that gradually decreases between the enlarged portion 440 and the seating portion 444. As shown in FIG. 3A, the enlarged portion 440 can bear against an inner surface of the nozzle main body 260. The seating portion 444 can press the nozzle orifice 318 against the nozzle main body 260 to limit or substantially eliminate unwanted movement of the nozzle orifice 318.

Referring to FIG. 5, the mount main body 410 and the guide tube 458 cooperate to define a channel 470. The channel 470 extends between a seating face 474 of the seating portion 444 and a downstream end 462 of the tube 458. The mount main body 410 can have a stepped region 472 for receiving the tube 458.

The tube 458 can help guide fluid flow through the mixing assembly 240. For example, as shown in FIGS. 3A and 3B, the tube 458 protrudes into and directs the flow of fluid 485 through the mixing chamber 380. The downstream end 462 of the tube 458 can be positioned upstream, within, or downstream of the media flow 484 being introduced to the fluid flow 485, depending on the desired interaction of the media flow 484 and fluid flow 485.

The tube 458 can be formed of different materials suitable for contacting different types of flows. For improved wear characteristics, the tube 458 can be made, in whole or in part, of a hardened material that can be repeatedly exposed to the fluid jet exiting the nozzle orifice 318. The hardened material can be harder than the material (e.g., steel) forming the mount main body 410 in order to keep damage to the tube 458 below or at an acceptable level. The tube 458, for example, can erode less than traditional materials used to form orifice mounts and, consequently, can retain its original shape even after extended use. The softer mount main body 410 can limit damage to the nozzle main body 260.

Hardened materials may include, without limitation, tungsten carbide, titanium carbide, and other abrasion resistant or high wear materials that can withstand exposure to fluid jets. Various types of testing methods (e.g., the Rockwell hardness test or Brinell hardness test) can be used to determine the hardness of a material. In some non-limiting exemplary embodiments, the tube 458 is made, in whole or in part, of a material having a hardness that is greater than about 3 R_c (Rockwell, Scale C), 5 R_c , 10 R_c , or 20 R_c of the hardness of the mount main body 410 and/or the nozzle main body 260.

The tube 458 can be made, in whole or in part, of a material having a hardness greater than about 62 R_c , 64 R_c , 66 R_c , 67 R_c , and 69 R_c , or ranges encompassing such hardness values. In some embodiments, the orifice mount 390 can be formed, in whole or in part, of a durable material (e.g., one or more metals with desirable fatigue properties, such as toughness) and the tube 458 can be formed, in whole or in part, of a high wear material. In some embodiments, for example, the orifice mount 390 is formed of steel and the tube 458 is formed of tungsten carbide.

FIG. 6 shows an orifice mount 492 with a completely buried tube 490. An upstream end 494 and a downstream end 496 of the tube 490 are proximate or flush with respective faces 500, 502 of the orifice mount 492. FIG. 7 shows an orifice mount 510 without a separate tube. A coating 516 can be applied to an inner surface of a throughhole the orifice mount 510. The coating 516 can comprise a hardened material, or other suitable high wear materials.

Referring again to FIG. 3B, the delivery conduit 250 includes the outlet 274, an inlet 530, and a channel 520 extending between the outlet 274 and the inlet 530. The media 484 can be combined with the fluid jet in the mixing chamber 380 to form an abrasive fluid jet 337 that proceeds into and through the channel 520. The abrasive fluid jet 337 proceeds along the channel 520 and is ultimately delivered from the outlet 274 as the fluid jet 134.

The delivery conduit 250 can be a mixing tube, focusing tube, or other type of conduit configured to produce a desired flow (e.g., a coherent flow in the form of a round jet, fan jet, etc.). The delivery conduit 250 can have an axial length L_{DC} that is equal to or less than about 2 inches (5.1 cm). In some embodiments, the length L_{DC} is in the range of about 0.5 inch (1.3 cm) to about 2 inches (5.1 cm). In some embodiments, the length L_{DC} can be equal to or less than about 1 inch (2.5 cm). The average diameter of the channel 520 can be equal to or less than about 0.05 inch (1.3 mm). In some embodiments, the average diameter of the channel 520 is in the range of about 0.002 inch (0.05 mm) to about 0.05 inch (1.3 mm). The length L_{DC} , diameter of the channel 520, and other design parameters can be selected to achieve the desired mixing action of the fluid mixture passing therethrough. In some embodiments, a ratio of the length L_{DC} to the average diameter of the channel 520 is equal to or less than about 25, 20, or 15, or ranges encompassing such ratios. In some embodiments, the ratio of the length L_{DC} to the average diameter of the channel 520 is in the range of about 15 to about 25.

The relatively small distance between the outlet 274 and the nozzle orifice 318 can help reduce the size of the nozzle system 130. In some embodiments, the distance from the outlet 274 to the nozzle orifice 318 is in the range of about 0.5 inch (1.3 cm) to about 3 inches (7.6 cm). Such embodiments permit enhanced mixing of abrasives, if any, and the high pressure feed fluid F. In some embodiments, the distance from the outlet 274 to the nozzle orifice 318 is in the range of about 0.25 inch (0.64 cm) to about 2 inches (5.1 cm). In such embodiments, the dimension D_c of the nozzle system 130 (see FIG. 1) can be less than about 4 inches, 5 inches, or 6 inches, thereby permitting the nozzle system 130 to be passed through relatively small spaces.

Referring again to FIG. 3A, the media feed line 170 is in fluid communication with the media inlet 200 of the media feed assembly 230. The media inlet 200 defines a channel 540 for media flow therethrough. A mounting portion 546 of the media inlet 200 is temporarily or permanently coupled to the nozzle main body 260. A coupling portion 550 of the media inlet 200 is temporarily or permanently coupled to the media feed line 170. A media delivery conduit 558 defining a media

passageway **560** extends between the media inlet **200** and mixing assembly **240**. The illustrated media delivery conduit **558** is generally parallel to the fluid flow conduit **217**, although this is not required. In some embodiments, the media delivery conduit **558** can be positioned on a different plane than the fluid flow conduit **217**.

The media feed assembly **230** further includes a media outlet **570** positioned upstream of the delivery conduit **250** and downstream of the orifice mount **390** with respect to the fluid flowing from the nozzle orifice **318**. Media **484** from the media outlet **570** may combine with the fluid flow from the orifice mount **390** to form the abrasive fluid entering the delivery conduit **250**.

FIGS. **8** and **9** show horizontally oriented nozzle systems that can be generally similar to the nozzle system **130** of FIG. **1**. A nozzle system **580** of FIG. **8** is processing a bevel **582** of a workpiece **586**. A delivery conduit **590** of the nozzle system **580** delivers a fluid jet **588** at an acute angle β (illustrated as about 45 degrees) with respect to a longitudinal axis **592** of the nozzle system **580**. Other angles are also possible. For example, FIG. **9** shows a nozzle system **632** including a delivery conduit **620** delivering a fluid jet **622** at an obtuse angle β (illustrated as about 100 degrees) with respect to a longitudinal axis **630** of the nozzle system **632**. The angle β can be selected based on the processing criteria related to the process to be performed. Other angles (e.g., angles orthogonal to a second non-linear section **614**) are also possible.

The nozzle system **580** of FIG. **8** further includes a fluid delivery conduit **598** having a flow redirector **596** that is somewhat V-shaped (as viewed from the side). The illustrated flow redirector **596** includes a first non-linear section **612** and the second non-linear section **614** connected to the first angled section **612**. The illustrated non-linear sections **612**, **614** are angled sections, and because each of the angled sections **612**, **614** defines an obtuse angle, fluid can flow through the flow redirector **596** without causing significant damage to inner surfaces of the flow redirector **596**.

The nozzle system **580** can generate the fluid jet **588** with a relatively high flow rate, even if the fluid jet **588** is at a relatively small acute angle β to process angled surfaces, such as the bevel **582** of FIG. **8**. The nozzle system **580** can access locations with relatively small amounts of clearance to process angled surfaces. The number and configuration of non-linear sections of the flow redirector **596** can be selected based on operating parameters, such as desired flow rate, size of the nozzle system **580**, and orientation and position of the fluid jet **588**, as well as other parameters that may affect the speed and quality of processing.

FIG. **10** shows a nozzle system **648** including a secondary port **650** for delivering fluid A (indicated by the arrows **658**) into a mixing device **654**. The flow of fluid A, such as air, can be used to adjust one or more flow criteria of the fluid jet **670**. The illustrated secondary port **650** extends between an outlet **681** positioned along a mixing chamber **684** and an inlet **683** positioned along the outermost surface **690** of a nozzle main body **692**. Air passing through the secondary port **650** can help prevent media from impacting the downstream section of the orifice mount **699** and may therefore reduce wear of the orifice mount **699**. An air cushion can be formed within the mixing chamber **684**. For example, a stream of airflow can form an air cushion extending between the outlet **681** and a delivery conduit **700** to reduce or limit damage (e.g., wear or erosion) to the mixing chamber **684**, especially the surface opposite a media inlet **702**. The stream of airflow A can direct media, fluid F, or other matter in the mixing chamber **684** into and through the delivery conduit **700**. Even if media (or other matter) strikes the surfaces of the mixing chamber **684**, the

stream of airflow A can serve as an air cushion that reduces the impact velocity of the media to reduce or limit damage to the surfaces of the mixing chamber **684**. The media, fluid F, and air A can therefore merge together in the mixing chamber **684** while keeping damage to the nozzle system **648** at or below an acceptable level.

FIGS. **11-13** illustrate mixing devices that may be generally similar to each other and, accordingly, the following description of one of the mixing devices applies equally to the other, unless indicated otherwise. FIG. **11** shows a mixing device **710** including an orifice mount **714** sandwiched between a nozzle main body **716** and a manifold **718** having a manifold inlet **722** for receiving media from a media feed conduit **726**. A sealing surface **759** forms a fluid tight seal between the orifice mount **714** and nozzle main body **716**. A delivery conduit **730** is coupled to the nozzle main body **716** via a coupler **734**.

The orifice mount **714** includes a tapered sealing portion **760** (illustrated as an approximately frusto-conical surface) for contacting the nozzle main body **716**, a guide tube **744**, and an enlarged body **746** generally between the seating portion **760** and the guide tube **744**. Because the manifold **718** axially retains the orifice mount **714**, the axial length of the orifice mount **714** of FIG. **11** can be smaller than the axial length of the orifice mount **390** of FIGS. **3A** and **3B**. The orifice mount **714** of FIG. **11** can have a smaller axial length because it does not need to accommodate external threads or other coupling features.

The illustrated seating portion **760** of the orifice mount **714** and a complementary surface **759** of the nozzle main body **716** are both generally frusto-conical to facilitate self-centering of the orifice mount **714**. Additionally, when the orifice mount **714** is pressed against the surface **759**, a seal **760** can be formed. Various types of materials can be used to form the seating portion **760** and the surface **759** of the orifice mount **714**. One or more metals can be used to form at least a portion of the seating portion **760** and the surface **759** in order to form the desired seal **760**.

Because the manifold **718** presses the orifice mount **714** against the nozzle main body **716**, the manifold **718** can experience significant compressive forces. The orifice mount **714** or manifold **718** or both can experience significant compressive loads without appreciable damage via, for example, cracking (e.g., micro-cracking), buckling, plastic deformation, and other failure modes. Suitable materials for forming, in whole or in part, the orifice mount **714** and/or manifold **718** include, without limitation, metals (e.g., steel, aluminum, and the like), ceramics, and other materials selected based on fracture toughness, wear characteristics, yield strength, and the like. For example, the orifice mount **714** is made of steel and the manifold **718** is made of ceramic.

The coupler **734** can securely couple the delivery conduit **730** in the nozzle main body **716**. The coupler **734** can have engagement features (e.g., external threads) that mate with complementary engagement features (e.g., internal threads) of the nozzle main body **716**. The coupler **734** can be conveniently moved axially through the nozzle main body **716** until it presses against the manifold **718**, which in turn presses against the orifice mount **714**.

An interference fit, press fit, shrink fit, or other type of fit can be used to limit or substantially eliminate unwanted movement of the delivery conduit **730** with respect to the coupler **734**. Other coupling means can also be used. For example, one or more adhesives, welds, fasteners (e.g., set-screws), or set of complementary threads can be used. An

adhesive in some embodiments can be applied between an outer surface of the delivery conduit 730 and an interior surface of the coupler 734.

Venting of orifice mounts can be used to adjust jet coherency, as well as other flow criteria. For example, venting can create a higher pressure area at the upstream end of the orifice flow passage 744 than the pressure in the mixing chamber area, and accordingly, the media coming through the orifice flow passage 744 does not travel upstream. FIG. 12 shows a secondary port 818 extending through an orifice mount 820 and a nozzle main body 826. The secondary port 818 includes an inner secondary port 822 and an outer secondary port 832. The inner secondary port 822 extends between a gap between the orifice mount 820 and the nozzle main body 826 and a channel 845. The outer secondary port 832 extends between the gap and the outer surface 832 of the nozzle main body 826.

In some embodiments, including the illustrated embodiment of FIG. 12, a secondary feed line 840 is in communication with the outer secondary port 832 and a secondary fluid source 844. The secondary fluid source 844, in some embodiments, pressurizes a substance (e.g., a fluid, media, and the like) that is delivered at a selected flow rate into the orifice mount 820 via the secondary port 818 in order to adjust one or more flow criteria, such as the dispersion of the fluid jet, coherency of the fluid jet, and other flow criteria that effect the performance of the fluid jet, as well as the ratio of constituents of the fluid jet. The secondary fluid source 844 can include a pump (e.g., a low pressure pump) or other types of pressurizing devices.

Alternatively, the outer secondary port 832 can be exposed to the surrounding environment. Air drawn from the surrounding environment through the secondary port 818 can mix with the fluid jet passing through the channel 845 of the orifice mount 820.

FIG. 13 shows an orifice mount 856 having a downstream end 866 positioned to engage a media flow. The orifice mount 856 includes a guide tube 858 extending downstream of at least a portion of a manifold media inlet 860 with respect to the direction of the primary fluid flow (indicated by the arrow 862). The illustrated downstream end 866 of the tube 858 is positioned downstream, with respect to the direction of the primary fluid flow, of the manifold media inlet 860. Abrasive media passing through the manifold media inlet 860 may strike and flow around the tube 858 and then mix with the primary fluid flowing out of the tube 858.

FIG. 14 illustrates a nozzle system 900 without a mixing chamber so as to further reduce the size of the nozzle system 900. The nozzle system 900 includes a mixing device 902 with one or more removable components. The components of the mixing device 902 can be removed in order to perform maintenance (e.g., either on the component or on the nozzle system itself), replace the component, and/or perform inspections.

The mixing device 902 of FIG. 14 includes a removable orifice assembly 906 in a receiving slot 910 of a nozzle main body 912 (see FIG. 15) and a slender delivery conduit 916. If needed or desired, the entire orifice assembly 906 can be conveniently removed from the nozzle system 900 for disassembling, as shown in FIG. 16.

Referring to FIGS. 14 and 16, the orifice assembly 906 includes a face seal 970, a nozzle orifice 972, and an orifice mount 974 having a receiving section 978. The receiving section 978 surrounds and retains both the face seal 970 and nozzle orifice 972. FIG. 14 shows the nozzle orifice 972 between the face seal 970 and a back wall 980 of the orifice mount 974. A cylindrical sidewall 984 of the receiving section

978 can closely receive and maintain proper alignment of both the nozzle orifice 972 and face seal 970.

With respect to FIG. 16, a front face 990 of the orifice mount 974 and a front surface 992 of the face seal 970 can be generally flush so that the orifice assembly 906 can be slid into and out of the receiving slot 910 without appreciable interference between the face seal 970 and the nozzle main body 912. In the illustrated embodiment, the front face 990 and a rear face 996 of the orifice mount 974 can slide smoothly against a corresponding front surface 999 and a rear surface 1000 of the receiving slot 910.

The face seal 970 of FIG. 16 includes a main body 1002 and a sealing member 1004 disposed in a groove 1006 (FIG. 14) extending circumferentially about the main body 1002. The main body 1002 defines a central bore 1010 and includes an outer surface 1012 (FIG. 16) dimensioned to fit closely within the receiving section 978 of the orifice mount 974.

The sealing member 1004 of FIG. 16 can be an O-ring, annular compressible member, or other type of component capable of forming a fluid tight interface between the face seal 970 and the orifice mount 974. The illustrated groove 1006 and sealing member 1004 are positioned generally midway along the axial length of the sealing member 1004. The groove 1006 and sealing member 1004 can also be at other locations, and other types of sealing arrangements can be used.

Various types of retaining means may be employed to retain the mixing devices in desired positions in the nozzle main body. FIGS. 14 and 15 show a retaining member 1030 surrounding a portion of the orifice assembly 906. The retaining member 1030 is fixedly coupled to an inner surface 1034 of the slot 910 and can tightly hold the orifice assembly 906 to maintain proper alignment of the channels 1010, 1040, 950. Additionally or alternatively, one or more retaining clips, clamps, pins, fasteners, or brackets can be used to hold one or more components of the nozzle system 900, if needed or desired.

An external mounting assembly 920 for retaining the delivery conduit 916 is coupled to the nozzle main body 912. The external mounting assembly 920 includes a protective plate 921 that can be pressed against and cover a section of the nozzle main body 912. The protective plate 921 can be a generally planar sheet made of a hardened material suitable for protecting the nozzle main body 912, even if the protective plate 921 strikes the workpiece. The delivery conduit 916 of FIG. 14 is configured to combine a primary fluid flow and a secondary media flow. The delivery conduit 916 includes a secondary port 944 positioned along the channel 950. A media flow conduit 940 includes an inner surface formed of a hardened material. The illustrated media flow conduit 940 is a tubular member capable of resisting abrasive wear and positioned in the nozzle main body 912. The media flow passing through the secondary port 944 and the primary fluid flow from the orifice assembly 906 can be combined at a mixing section 1060 of the channel 950.

As shown in FIG. 16, the longitudinal length L_{DC} of the delivery conduit 916 can be relatively large because of the short length of the orifice assembly 906. Because the delivery conduit 250 defines a mixing chamber, the longitudinal length L_{DC} of the delivery conduit 916 can be increased to achieve the desired amount of mixing. A length L_{OA} of the orifice assembly 906 can be relatively small because it does not have external threads. In some embodiments, the length L_{OA} of the orifice assembly 906 is in the range of about 0.1 inch (2.5 mm) to about 0.5 inch (12.7 mm). In some embodiments, the length L_{OA} of the orifice assembly 906 is about 0.2 inches (5.1 mm). In some embodiments, the longitudinal

15

length L_{DC} of the delivery conduit **916** is in the range of about 0.5 inch (12.7 mm) to about 3 inches (76.2 mm). Such delivery conduits **916** are well suited for receiving a wide range of medias and producing highly focused coherent abrasive water jets. In some embodiments, the longitudinal length L_{DC} is in the range of about 1 inch (25.4 mm) to about 3 inches (76.2 mm). If the delivery conduit **916** becomes damaged, the mounting assembly **920** can be operated to release and remove the damaged delivery conduit **916**.

FIG. **17** shows a nozzle assembly **1100** that may be generally similar to the nozzle assembly **900** of FIG. **16**. In general, the nozzle assembly **1100** includes an orifice assembly **1104** interposed between a face seal **1108** and a delivery conduit **1110**. The orifice assembly **1104** includes a thin disk-shaped orifice mount **1112** to further reduce the size of the nozzle assembly **1100**. A nozzle orifice **1111** is positioned in a centrally disposed recess **1113** of the orifice mount **1112**. The nozzle assembly **1100** further includes a nozzle main body **1114** in which the face seal **1108** is positioned at a downstream end **1118** of the fluid feed conduit **1120**. The face seal **1108** and downstream end **1118** of the fluid feed conduit **1120** cooperate to form an angled flow redirector **1122**.

The face seal **1108** is dimensioned to fit within a receiving bore **1124** of the main body **1114** and includes a flow passageway **1128** with a varying axial cross-sectional area in order to accelerate the fluid flow. In the illustrated embodiment of FIG. **17**, the passageway **1128** of the face seal **1108** tapers inwardly from an entrance aperture **1130** to an exit aperture **1132**. The face seal **1108** can be made, in whole or in part, of a metal, polymers, plastic, rubber, and other materials suitable contacting the mounting orifice **1112** and through which the primary fluid flows.

FIG. **18** illustrates a nozzle system **1200** with a modular fluid feed assembly **1202** and a modular media feed assembly **1204**. The fluid feed assembly **1202** includes a fluid flow conduit **1230** that can be removably coupled to a main body **1214** of the nozzle system **1200**. Similarly, the modular media feed assembly **1204** can include a media flow conduit **1234** that can be removably coupled to the main body **1214**. In alternative embodiments, the fluid flow conduit **1230** and the media flow conduit **1234** can be permanently coupled to the main body **1214** of the nozzle system **1200**.

As noted above, the fluid delivery systems and nozzle systems discussed herein can be used in numerous applications. Additionally, all of the above U.S. patents, U.S. patent application publications, U.S. patent applications, foreign patents, foreign patent applications and non-patent publications referred to in this specification and/or listed in the Application Data Sheet, U.S. Pat. Nos. 6,000,308 and 5,512,318 are incorporated herein by reference, in their entirety.

From the foregoing it will be appreciated that, although specific embodiments of the invention have been described herein for purposes of illustration, various modifications may be made without deviating from the spirit and scope of the invention. Accordingly, the invention is not limited except as by the appended claims.

What is claimed is:

1. A nozzle system for generating a high-pressure abrasive waterjet, comprising:

a nozzle main body consisting of a single piece of material, the single piece of material comprising a fluid flow conduit and a media flow conduit extending therethrough, the fluid flow conduit extending through the single piece of material of the nozzle main body from a high-pressure water inlet toward an outlet through which a high-pressure waterjet exits the nozzle system, the fluid flow conduit having an upstream section and a downstream

16

section, the upstream section comprising a flow redirector configured and dimensioned to receive high-pressure water flow traveling in a first direction and to output the high-pressure water flow in a second direction toward the downstream section of the fluid flow conduit, the first direction being substantially different than the second direction, the media flow conduit extending through the single piece of material between a media inlet and the downstream section of the fluid flow conduit such that abrasive media passing through the media flow conduit is mixed with the high-pressure waterjet;

a nozzle orifice interposed between the upstream and downstream sections of the fluid flow conduit within the single piece of material of the nozzle main body such that high-pressure water in the upstream section passes through an aperture of the nozzle orifice to generate the high-pressure waterjet; and

a delivery conduit positioned downstream of the nozzle orifice within the downstream section of the fluid flow conduit of the nozzle main body, the delivery conduit including the outlet through which the high-pressure waterjet exits the nozzle system.

2. The nozzle system of claim **1**, wherein the flow redirector is an angled elbow.

3. The nozzle system of claim **1**, wherein the flow redirector defines an angle between the first direction and the second direction, and the angle is in the range of about 10 degrees to about 170 degrees.

4. The nozzle system of claim **1**, wherein the flow redirector defines an angle between the first direction and the second direction, and the angle is about 90 degrees.

5. The nozzle system of claim **1**, wherein a distance between the nozzle orifice and the outlet of the delivery conduit is less than about 6 inches.

6. The nozzle system of claim **5**, wherein the distance between the nozzle orifice and the outlet delivery conduit is less than about 2 inches.

7. The nozzle system of claim **1**, wherein the nozzle orifice defines a centerline, and a distance between the centerline of the nozzle orifice and an outer edge of an end of the single piece of material of the nozzle main body is equal to or less than about 0.5 inch.

8. The nozzle system of claim **1**, wherein the media flow conduit is configured to carry a sufficient amount of abrasive media capable of mixing with the high-pressure waterjet so as to form a high-pressure abrasive waterjet for cutting metal.

9. A low-profile nozzle system for a high-pressure abrasive waterjet delivery system, comprising:

a nozzle main body comprising a piece of material and having a fluid flow conduit and a media flow conduit both extending through the piece of material such that the nozzle main body is a single component with the fluid flow conduit and media flow conduit being passages therein;

a delivery conduit coupled to the nozzle main body and having an outlet for outputting a high-pressure abrasive waterjet from the nozzle system; and

a nozzle orifice positioned within the fluid flow conduit of the nozzle main body upstream of the outlet of the delivery conduit, the nozzle orifice configured to generate a high-pressure waterjet when high-pressure water passes through an aperture of the nozzle orifice;

wherein the fluid flow conduit within the piece of material of the nozzle main body includes an upstream section positioned upstream of the nozzle orifice and a downstream section positioned downstream of the nozzle orifice, the upstream section comprising an angled elbow

17

for receiving a high-pressure water flow traveling in a first direction and outputting the high-pressure water flow traveling in a second direction towards the nozzle orifice, the first direction being different than the second direction; and

wherein the media flow conduit intersects the downstream section of the fluid flow conduit within the piece of material of the nozzle main body, and the media flow conduit is configured to deliver abrasive media that mixes with the high-pressure waterjet generated by the nozzle orifice to form the high-pressure abrasive waterjet delivered out of the outlet of the delivery conduit.

10. The nozzle system of claim 9, wherein the angled elbow defines an angle in the range of about 10 degrees to about 170 degrees between the first direction and the second direction.

11. The nozzle system of claim 9, wherein the delivery conduit comprising comprises a channel through which the high-pressure waterjet passes and a secondary port extending from the channel to the media flow conduit.

12. The nozzle system of claim 9, wherein the delivery conduit is a mixing tube comprising a channel extending therethrough, wherein a ratio of an axial length of the mixing tube to an average diameter of the channel is equal to or less than about 100.

13. The nozzle system of claim 9, further comprising: an orifice mount positioned between the nozzle orifice and the outlet of the delivery conduit, the orifice mount having a channel extending therethrough, the channel of the orifice mount positioned within at least a portion of the downstream section of the fluid flow conduit of the nozzle main body.

14. The nozzle system of claim 13, wherein at least a portion of the orifice mount defining the channel comprises tungsten carbide.

15. The nozzle system of claim 9, further comprising: an orifice mount positioned between the nozzle orifice and the outlet of the delivery conduit, the orifice mount comprising a channel through which the high-pressure waterjet passes, a main body for engaging the nozzle orifice, and a guide tube coupled to the main body, the guide tube defining at least a portion of the channel.

16. The nozzle system of claim 9, further comprising: an orifice mount configured to hold the nozzle orifice, the orifice mount comprising a guide tube extending downstream of at least a portion of a downstream end of the media flow conduit with respect to a direction of travel of the high-pressure waterjet.

17. The nozzle system of claim 16 wherein the guide tube comprises a material harder than the orifice mount.

18. The nozzle system of claim 9, further comprising: an orifice mount between the nozzle orifice and the outlet of the delivery conduit, the orifice mount having a channel through which the high-pressure waterjet flows and a secondary port through which secondary fluid flows such that the secondary fluid and high-pressure waterjet are combined in the channel.

19. The nozzle system of claim 9, wherein the piece of material of the nozzle main body includes a mixing chamber defining at least a portion of the downstream section of the fluid flow conduit and into which the media flowing through the media flow conduit combines with the high-pressure waterjet and a secondary port connected to the mixing chamber through which fluid is vented.

20. The nozzle system of claim 9, wherein the outlet of the delivery conduit and the nozzle orifice are separated by a distance equal to or less than about 2 inches.

18

21. A nozzle system configured to generate a high-pressure abrasive media waterjet, the nozzle system comprising:

a delivery conduit having an outlet through which a high-pressure abrasive media waterjet exits the nozzle system;

a nozzle main body consisting of a piece of material, the piece of material including a fluid feed conduit and a media feed conduit extending through a portion thereof such that the fluid feed conduit and the media feed conduit define internal passages through the same piece of material, the fluid feed conduit comprising a first section, a second section, and a flow redirector between the first and second sections, and the flow redirector being configured to receive a high-pressure water flow traveling in a first direction through the first section and to direct the high-pressure water flow in a second direction angled with respect to the first direction; and

a nozzle orifice positioned within the nozzle main body downstream of the fluid redirector and configured to generate a high-pressure waterjet which mixes with abrasive delivered into the high-pressure waterjet through the media feed conduit to form the high-pressure abrasive media waterjet.

22. The nozzle system of claim 21, further comprising: an angle defined between the first direction and the second direction, the angle is less than about 170 degrees.

23. The nozzle system of claim 21, wherein the outlet of the delivery conduit and the nozzle orifice are separated by a distance equal to or less than about 2 inches.

24. The nozzle system of claim 23, wherein the distance is equal to or less than about 1.5 inches.

25. The nozzle system of claim 21, wherein the delivery conduit is a mixing tube positioned downstream of the nozzle orifice, the mixing tube comprising a channel, wherein a ratio of an axial length of the mixing tube to an average diameter of the channel is less than about 100.

26. The nozzle system of claim 21, further comprising: a removable orifice assembly configured to be moved into and out of a receiving slot of the piece of material of the nozzle main body, the orifice assembly comprising the nozzle orifice, an orifice mount dimensioned to hold the nozzle orifice within the receiving slot of the nozzle main body, and a sealing member configured to form a seal with the nozzle main body.

27. The nozzle system of claim 26, further comprising: a face seal positioned upstream of the nozzle orifice, and the face seal having a passageway that tapers inwardly from an entrance aperture to an exit aperture adjacent the nozzle orifice.

28. The nozzle system of claim 27, wherein the face seal is dimensioned to fit within a receiving bore of the piece of material of the nozzle main body, and the receiving bore extending from the receiving slot towards the flow redirector.

29. A low-profile nozzle system for a high-pressure abrasive waterjet delivery system, comprising:

a delivery conduit having a nozzle outlet for outputting an abrasive waterjet from the nozzle system;

a nozzle orifice positioned upstream of the nozzle outlet of the delivery conduit and configured to generate a waterjet when fluid passes through an aperture of the nozzle orifice; and

a nozzle main body consisting of a single piece of material, the delivery conduit removably coupled to the nozzle main body, the nozzle orifice removably installed within the nozzle main body, and the single piece of material comprising:

19

- a fluid flow conduit having an upstream section positioned upstream of the nozzle orifice and a downstream section positioned downstream of the nozzle orifice, the upstream section comprising an angled elbow for receiving a fluid flow traveling in a first direction and outputting the fluid flow traveling in a second direction towards the nozzle orifice, the first direction being different than the second direction; and
- a media flow conduit intersecting the downstream section of the fluid flow conduit, and the media flow conduit being configured to deliver abrasive media that mixes with a waterjet generated by the nozzle orifice to form the abrasive waterjet delivered out of the nozzle outlet of the delivery conduit.
- 30.** The nozzle system of claim **29**, wherein the single piece of material of the nozzle main body further comprises:
- a mixing chamber defining at least a portion of the downstream section of the fluid flow conduit and into which the media flowing through the media flow conduit combines with the waterjet; and
 - a secondary port connected to the mixing chamber and through which fluid is vented.
- 31.** The nozzle system of claim **29** wherein the nozzle outlet of the delivery conduit and the nozzle orifice are separated by a distance equal to or less than about 2 inches.
- 32.** The nozzle system of claim **29** wherein the nozzle orifice defines a centerline, and a distance between the centerline of the nozzle orifice and an outer edge of an end of the single piece of material of the nozzle main body of the nozzle system is equal to or less than about 0.5 inch.
- 33.** A low-profile nozzle system for generating a high-pressure abrasive waterjet, comprising:
- a media inlet for receiving abrasive media from a media delivery system;
 - a fluid inlet for receiving high-pressure water from a high-pressure water delivery system;
 - a nozzle orifice for receiving high-pressure water from the fluid inlet, the nozzle orifice defining a centerline, a distance between the centerline of the nozzle orifice and an outer edge of an end of the nozzle system being equal to or less than about 0.5 inch, and the nozzle orifice configured to generate a high-pressure waterjet using high-pressure water flowing through the fluid inlet;
 - a delivery conduit having an outlet through which the high-pressure waterjet exits the nozzle system; and
 - a nozzle main body consisting of a single piece of material, the delivery conduit removably coupled to the nozzle main body, the nozzle orifice removably installed within the nozzle main body, and the single piece of material comprising:
 - a fluid flow conduit extending from the fluid inlet toward the outlet of the delivery conduit, the fluid flow conduit having an upstream section and a downstream section, the nozzle orifice interposed between the upstream and downstream sections such that high-pressure water in the upstream section passes through an aperture of the nozzle orifice to generate a high-pressure waterjet in the downstream section, the upstream section comprising a flow redirector configured and dimensioned to receive high-pressure water flow traveling in a first direction and to output the high-pressure water flow in a second direction

20

- towards the nozzle orifice, the first direction being substantially different than the second direction; and a media flow conduit extending between the media inlet and the downstream section of the fluid flow conduit such that abrasive media passing through the media conduit is mixed with the waterjet generated by the nozzle orifice.
- 34.** The nozzle system of claim **33**, wherein the flow redirector defines an angle between the first direction and the second direction, and the angle is in the range of about 10 degrees to about 170 degrees.
- 35.** The nozzle system of claim **33**, wherein the flow redirector defines an angle between the first direction and the second direction, and the angle is about 90 degrees.
- 36.** The nozzle system of claim **33**, wherein a distance between the nozzle orifice and the outlet of the delivery conduit is less than about 2 inches.
- 37.** The nozzle system of claim **33**, wherein the delivery conduit is a mixing tube comprising a channel extending therethrough positioned downstream of the nozzle orifice, the mixing tube having a secondary port positioned along the channel to receive abrasive from the media flow conduit.
- 38.** The nozzle system of claim **33**, further comprising: an orifice mount positioned between the nozzle orifice and the outlet of the delivery conduit, the orifice mount having a channel extending therethrough, the channel positioned within a portion of the downstream section of the fluid flow conduit.
- 39.** The nozzle system of claim **33**, further comprising: an orifice mount positioned between the nozzle orifice and the outlet of the delivery conduit, the orifice mount comprising a channel through which the high-pressure waterjet passes, a main body for engaging the nozzle orifice, and a guide tube coupled to the main body, the guide tube defining at least a portion of the channel.
- 40.** The nozzle system of claim **21**, further comprising: a coupler to removably secure the delivery conduit to the nozzle main body in fluid communication with the fluid feed conduit, the coupler including external threads to mate with corresponding threads formed in the single piece of material of the nozzle main body.
- 41.** The nozzle system of claim **40** wherein the delivery conduit is a mixing tube and the coupler removably secures the mixing tube to the nozzle main body.
- 42.** The nozzle system of claim **40** wherein the nozzle orifice is held in position within the fluid feed conduit of the nozzle main body by the coupler.
- 43.** The nozzle system of claim **40**, further comprising: an orifice mount to support the nozzle orifice, the orifice mount urged against the single piece of the material of the nozzle main body as the external threads of the coupler are moved into threaded engagement with the corresponding threads formed in the single piece of material of the nozzle main body.
- 44.** A high-pressure abrasive waterjet cutting system including the nozzle system of claim **21** and further comprising:
- a high-pressure water delivery system coupled to the fluid feed component of the nozzle main body of the nozzle system to deliver high-pressure water thereto; and
 - an abrasive media delivery system coupled to the media feed conduit of the nozzle main body of the nozzle system to deliver abrasives thereto.

* * * * *

UNITED STATES PATENT AND TRADEMARK OFFICE
CERTIFICATE OF CORRECTION

PATENT NO. : 8,448,880 B2
APPLICATION NO. : 11/901961
DATED : May 28, 2013
INVENTOR(S) : Mohamed Hashish et al.

Page 1 of 1

It is certified that error appears in the above-identified patent and that said Letters Patent is hereby corrected as shown below:

In the Claims:

Column 17, Line 18:

“conduit comprising comprises a channel through which the” should read, --conduit comprises a channel through which the--.

Signed and Sealed this
Twelfth Day of August, 2014



Michelle K. Lee
Deputy Director of the United States Patent and Trademark Office