

US008424592B2

(12) **United States Patent**
Meshenky et al.

(10) **Patent No.:** **US 8,424,592 B2**
(45) **Date of Patent:** **Apr. 23, 2013**

(54) **HEAT EXCHANGER HAVING CONVOLUTED FIN END AND METHOD OF ASSEMBLING THE SAME**

(75) Inventors: **Steven P. Meshenky**, Racine, WI (US);
Charles M. Rastall, Cudahy, WI (US)

(73) Assignee: **Modine Manufacturing Company**,
Racine, WI (US)

(*) Notice: Subject to any disclaimer, the term of this patent is extended or adjusted under 35 U.S.C. 154(b) by 1301 days.

(21) Appl. No.: **12/182,747**

(22) Filed: **Jul. 30, 2008**

(65) **Prior Publication Data**

US 2009/0025916 A1 Jan. 29, 2009

Related U.S. Application Data

(63) Continuation-in-part of application No. 12/061,191, filed on Apr. 2, 2008, now abandoned, and a continuation-in-part of application No. PCT/US2008/051747, filed on Jan. 23, 2008.

(60) Provisional application No. 60/881,919, filed on Jan. 23, 2007.

(51) **Int. Cl.**
F28D 1/04 (2006.01)
F28F 1/14 (2006.01)

(52) **U.S. Cl.**
USPC **165/151**; 165/181

(58) **Field of Classification Search** 165/151, 165/152, 179, 181, 183, 81, 82, 84, 109.1
See application file for complete search history.

(56) **References Cited**

U.S. PATENT DOCUMENTS

1,553,093	A *	9/1925	Modine	165/151
2,178,095	A	10/1939	Bowser		
2,252,211	A	8/1941	Seemiller		
2,329,789	A	9/1943	Schank et al.		
2,615,687	A	10/1952	Simmons		
2,735,698	A	2/1956	Brinen		
2,782,009	A	2/1957	Rippingille		
2,819,731	A	1/1958	Louthan		
3,262,495	A	7/1966	Baird		

(Continued)

FOREIGN PATENT DOCUMENTS

CH	318033	12/1956
DE	2903543	8/1980

(Continued)

OTHER PUBLICATIONS

DE102009015892.8 German Search Report, dated Sep. 21, 2009, 4 pages.

(Continued)

Primary Examiner — Tho V Duong

(74) *Attorney, Agent, or Firm* — Michael Best & Friedrich LLP

(57) **ABSTRACT**

The present invention provides a heat exchanger for transferring heat between a first working fluid and a second working fluid. The heat exchanger can include a corrugated fin positionable along a flow path of the first working fluid between adjacent tube walls and being operable to increase heat transfer between the first working fluid and the second working fluid. The fin can include a leg defined between adjacent folds. The heat exchanger can also include a plurality of convolutions extending inwardly from a distal end of the leg and terminating at different distances from the end.

11 Claims, 12 Drawing Sheets

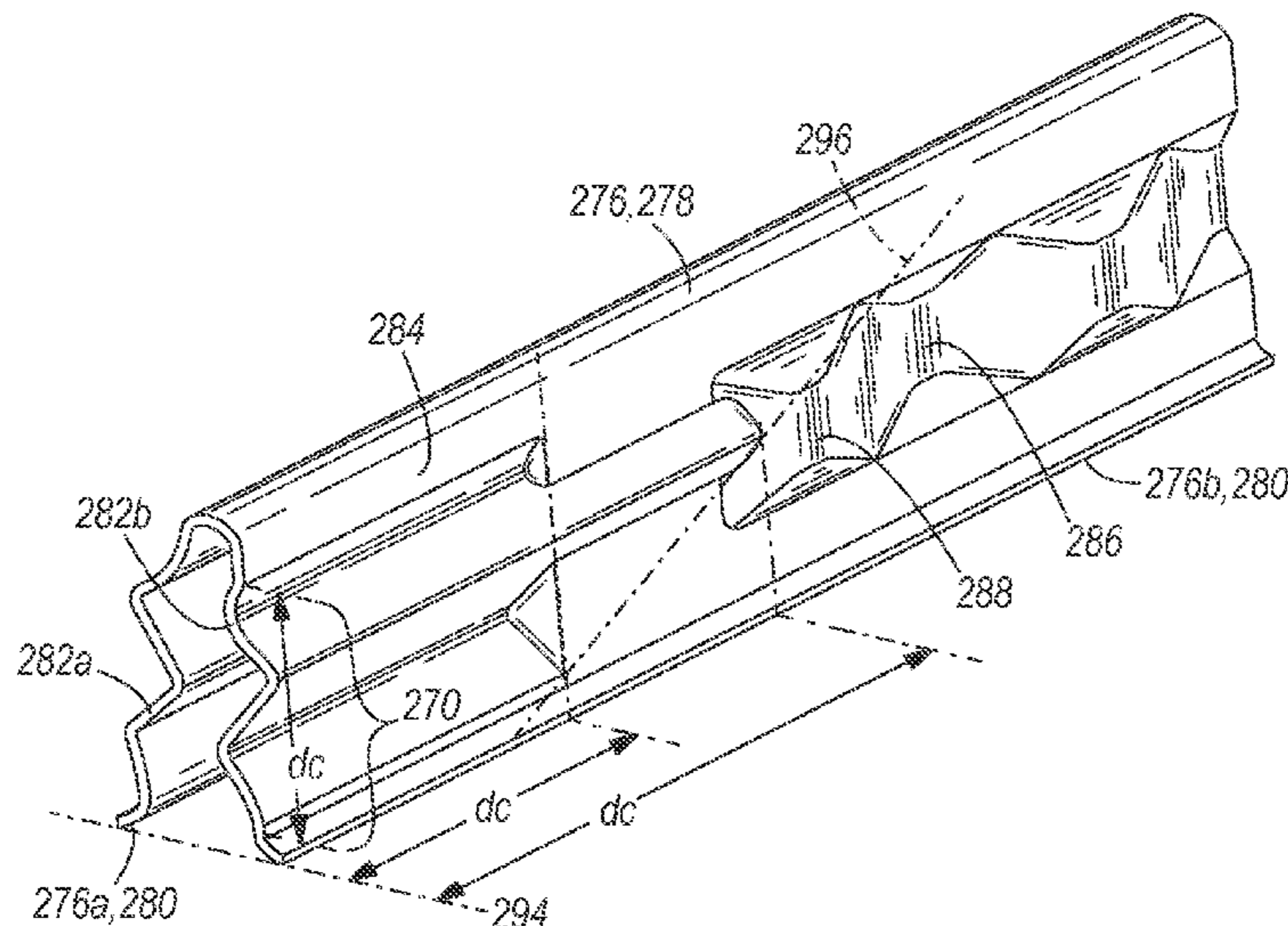

U.S. PATENT DOCUMENTS

3,313,343	A	4/1967	Ware et al.	
3,372,743	A	3/1968	Pall et al.	
4,096,616	A	6/1978	Coffinberry	
4,303,052	A	12/1981	Manfredo et al.	
4,420,039	A	12/1983	Dubrovsy	
4,428,418	A	1/1984	Beasley et al.	
4,436,145	A	3/1984	Manfredo et al.	
4,474,162	A	10/1984	Mason	
4,733,722	A	3/1988	Forbes et al.	
4,823,868	A	4/1989	Neebel	
4,903,762	A	2/1990	Marsais et al.	
5,029,636	A	7/1991	Kadle	
5,307,870	A	5/1994	Kamiya et al.	
5,372,187	A *	12/1994	Haushalter	165/109.1
5,417,280	A	5/1995	Hayashi et al.	
5,560,424	A	10/1996	Ogawa	
5,623,989	A *	4/1997	Kroger	165/152
5,625,229	A	4/1997	Kojima et al.	
5,636,685	A	6/1997	Gawve et al.	
5,671,806	A	9/1997	Schmalzried	
5,685,075	A	11/1997	Kato	
5,845,701	A	12/1998	Ruppel et al.	
5,996,633	A	12/1999	Kato	
6,019,169	A	2/2000	Ruppel et al.	
6,164,370	A	12/2000	Robinson et al.	
6,179,050	B1	1/2001	Dey et al.	
6,293,337	B1	9/2001	Strahle et al.	
6,435,268	B1 *	8/2002	Bhatti et al.	165/111
6,474,408	B1	11/2002	Yeh et al.	
6,729,388	B2 *	5/2004	Emrich et al.	165/153
6,904,965	B2	6/2005	Beck et al.	
6,920,918	B2	7/2005	Knecht et al.	
6,964,296	B2	11/2005	Memory et al.	
7,032,313	B2	4/2006	Memory et al.	
7,040,386	B2 *	5/2006	Shimoya et al.	165/153
7,077,190	B2	7/2006	Hayashi et al.	
7,107,680	B2	9/2006	Ueda	
7,174,948	B2	2/2007	Schindler et al.	
7,204,302	B2	4/2007	Shibagaki et al.	
7,255,159	B2	8/2007	Sagasser et al.	
7,367,386	B2	5/2008	Sato et al.	
7,487,589	B2	2/2009	Smith et al.	
8,016,025	B2	9/2011	Brost et al.	
2002/0007935	A1	1/2002	Marsala	
2003/0010480	A1	1/2003	Shibagaki et al.	
2004/0177668	A1	9/2004	Sagasser et al.	
2005/0161206	A1	7/2005	Ambros et al.	
2005/0224070	A1	10/2005	Hanai et al.	
2006/0201663	A1	9/2006	Strahle et al.	
2006/0231240	A1	10/2006	Rothenhofer et al.	
2006/0283585	A1	12/2006	Smith et al.	
2007/0012430	A1	1/2007	Duke et al.	
2007/0056721	A1	3/2007	Usui et al.	
2007/0114007	A1	5/2007	Schindler et al.	
2007/0175617	A1	8/2007	Brost et al.	
2007/0227715	A1	10/2007	Shimoya et al.	
2008/0041556	A1	2/2008	Braun et al.	
2008/0047696	A1	2/2008	Sperandei et al.	
2009/0194265	A1	8/2009	Nakamura	
2009/0250201	A1	10/2009	Grippe et al.	
2010/0025024	A1	2/2010	Meshenky et al.	

FOREIGN PATENT DOCUMENTS

DE	3743293	6/1989
DE	3815070	11/1989
DE	4223423	1/1994
DE	4307053	9/1994
DE	4313505	10/1994
DE	19519633	12/1996
DE	69315281	3/1998
DE	19644584	4/1998
DE	19651625	6/1998

DE	19853455	6/1999
DE	19836889	2/2000
DE	20003919	5/2000
DE	19902004	7/2000
DE	10040645	6/2002
DE	10238882	5/2003
DE	10242311	3/2004
DE	10359806	7/2005
DE	202004020294	5/2006
DE	102005034997	2/2007
EP	0242063	10/1987
EP	0584806	3/1994
EP	0704667	4/1996
EP	0974804	1/2000
EP	1376043	1/2004
EP	1411315	4/2004
EP	1464908	10/2004
EP	1522811	4/2005
EP	1544564	6/2005
FR	2447529	8/1980
FR	2777645	10/1999
GB	1129924	10/1968
JP	01305296	12/1989
JP	4198692	7/1992
JP	4332392	11/1992
JP	08025028	1/1996
JP	2000097589	4/2000
JP	2000121286	4/2000
JP	2000304486	11/2000
JP	2003106785	4/2003
JP	2003240387	8/2003
JP	2007003029	1/2007
JP	2007225190	9/2007
RU	2047081	10/1995
WO	2004085947	10/2004
WO	2005001366	1/2005
WO	2006010463	2/2006

OTHER PUBLICATIONS

Office Action from the Patent Office of the People's Republic of China for Application No. 200910133634.3 dated Feb. 16, 2012 (Translation and Original, 14 pages).

First Office Action from the State Intellectual Property Office of the People's Republic of China for Application No. 200880002935.6 dated Jul. 15, 2010 (3 pages—English Translation).

Office Action from United States Patent office for U.S. Appl. No. 11/594,454 dated Feb. 3, 2010 (8 pages).

PCT/US2008/051747 International Preliminary Report on Patentability dated Aug. 6, 2009 (6 pages).

Chinese Office Action for Application No. 200880002935.6 dated Jan. 26, 2011 (3 pages).

Office Action Non-Final Rejection for U.S. Appl. No. 11/015,159 dated Nov. 9, 2007 (10 pages).

Office Action Final Rejection for U.S. Appl. No. 11/015,159 dated Jun. 11, 2008 (11 pages).

Office Action Request for Restriction / Election for U.S. Appl. No. 11/015,159 dated Jan. 7, 2009 (5 pages).

Office Action Non-Final Rejection for U.S. Appl. No. 11/015,159 dated May 6, 2009 (8 pages).

Office Action Final Rejection for U.S. Appl. No. 11/015,159 dated Nov. 24, 2009 (6 pages).

Office Action Non-Final Rejection for U.S. Appl. No. 11/015,159 dated Apr. 13, 2010 (6 pages).

Office Action Examiner Interview Summary for U.S. Appl. No. 11/015,159 dated Jun. 17, 2010 (4 pages).

Office Action Final Rejection for U.S. Appl. No. 11/015,159 dated Dec. 3, 2010 (6 pages).

PCT/US2008/051747 International Search Report, 3 pages, Dated Jun. 5, 2008.

* cited by examiner

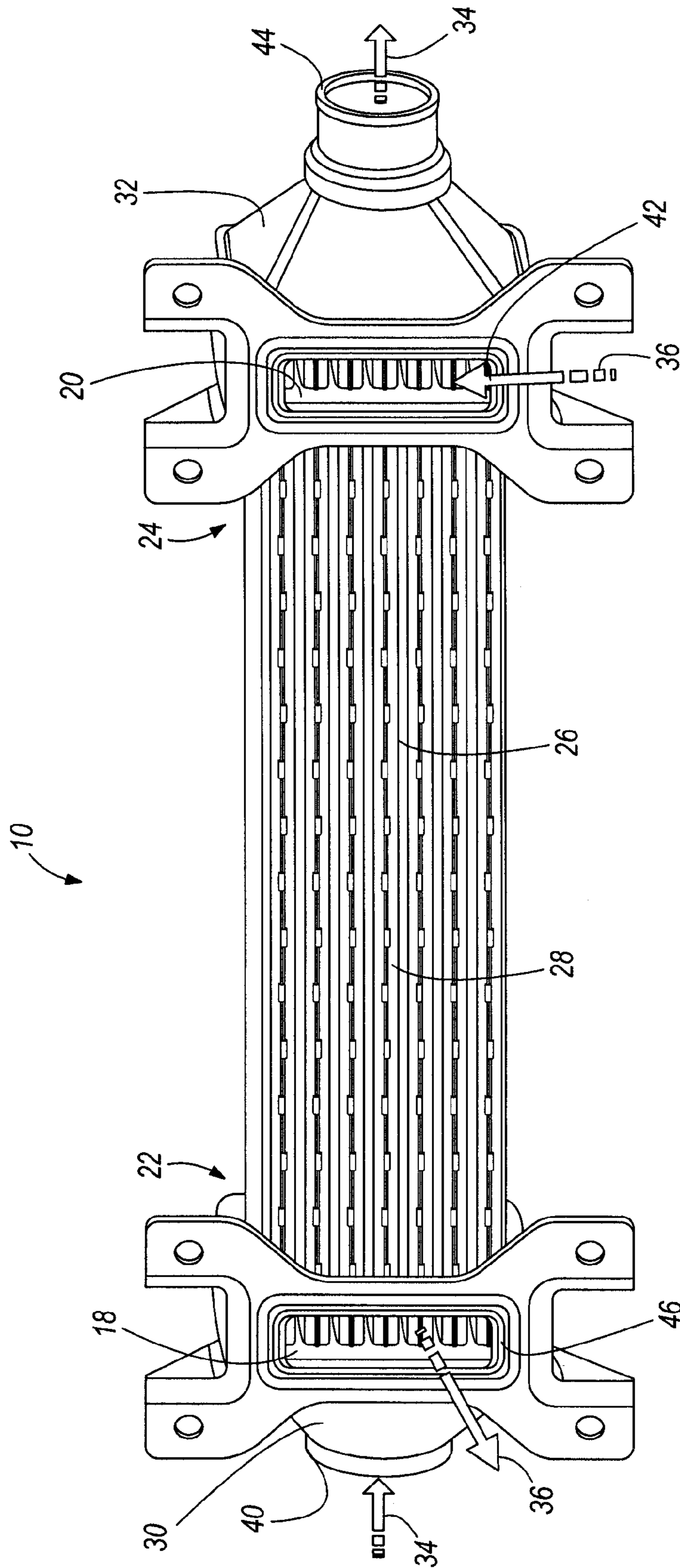

FIG. 1

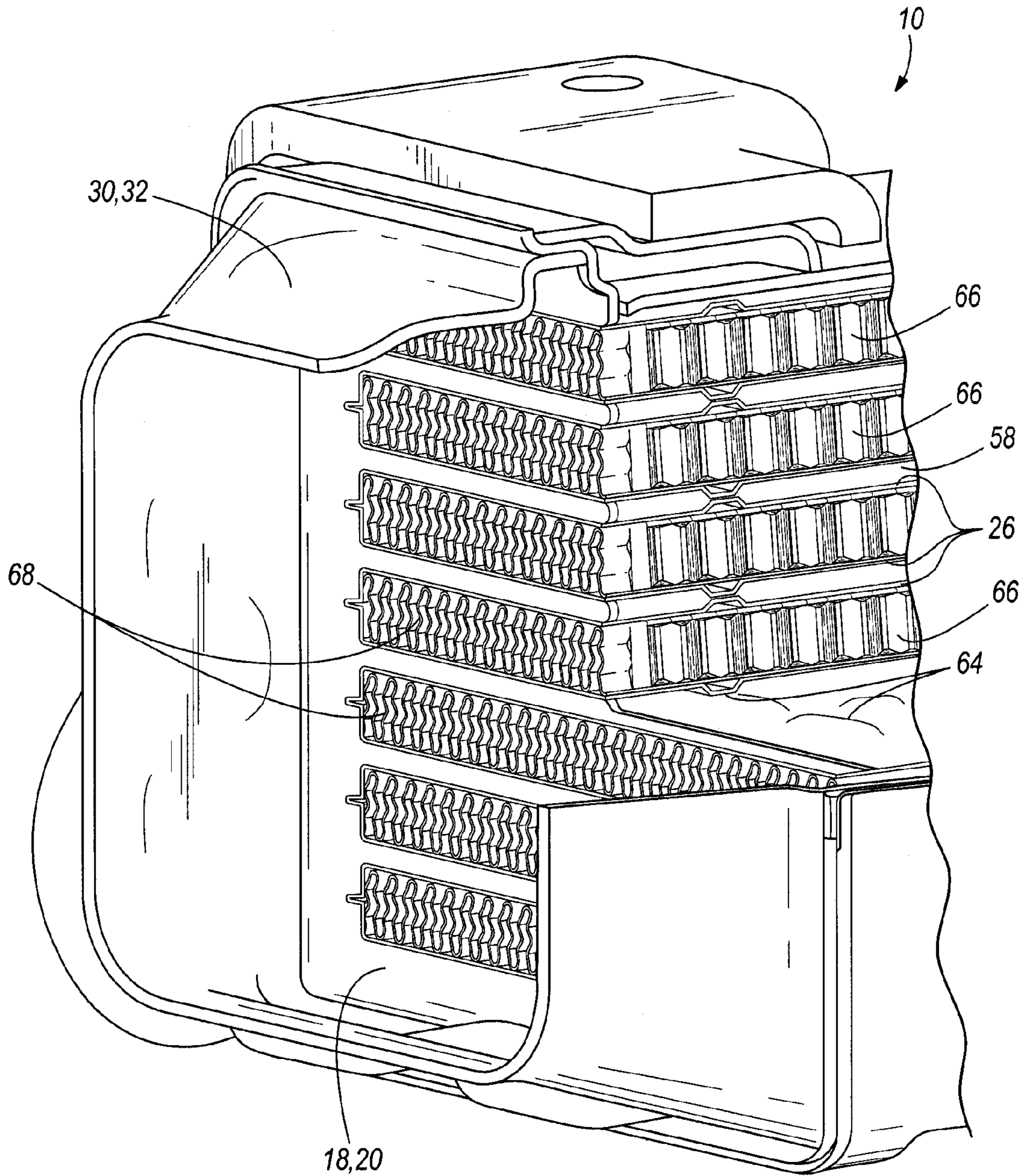
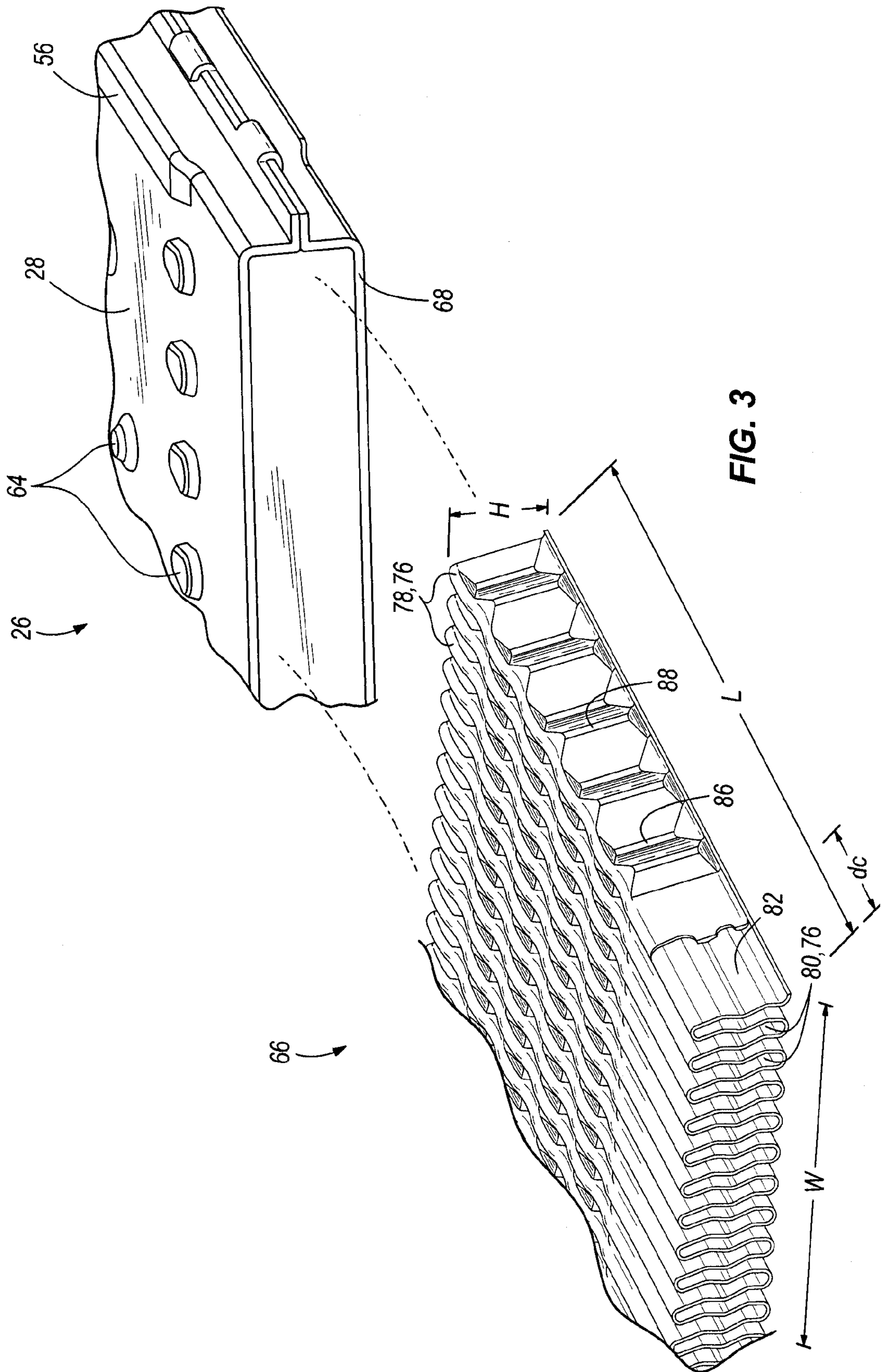
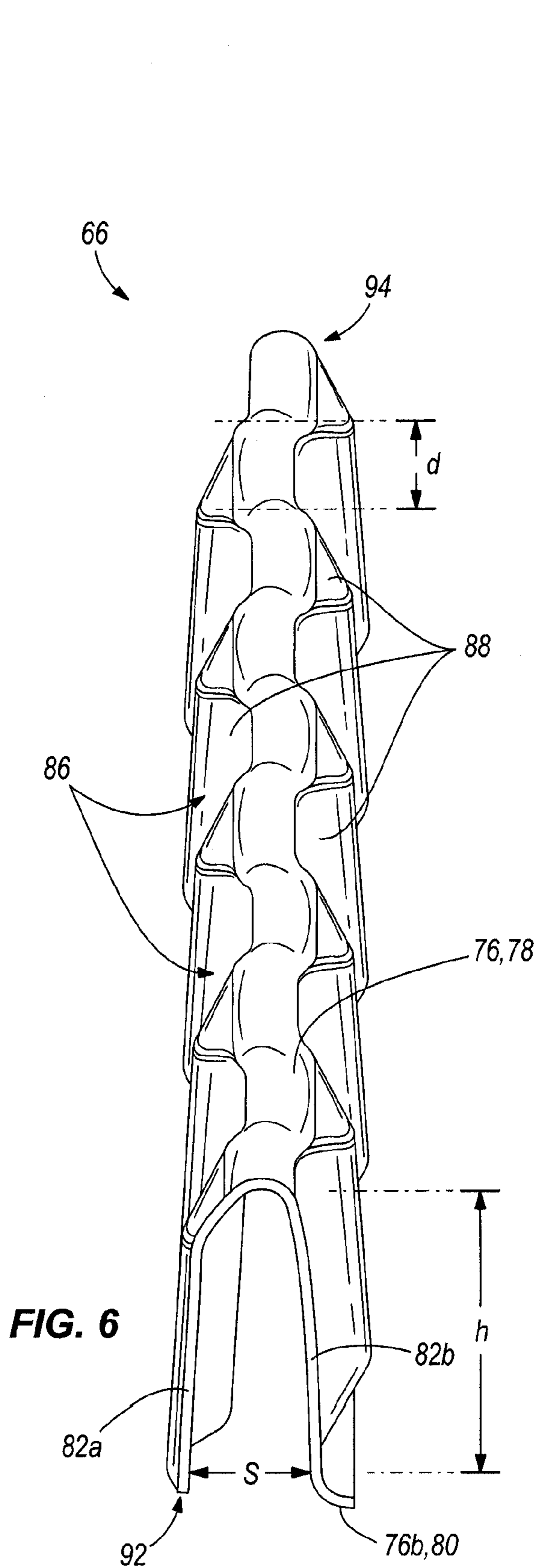
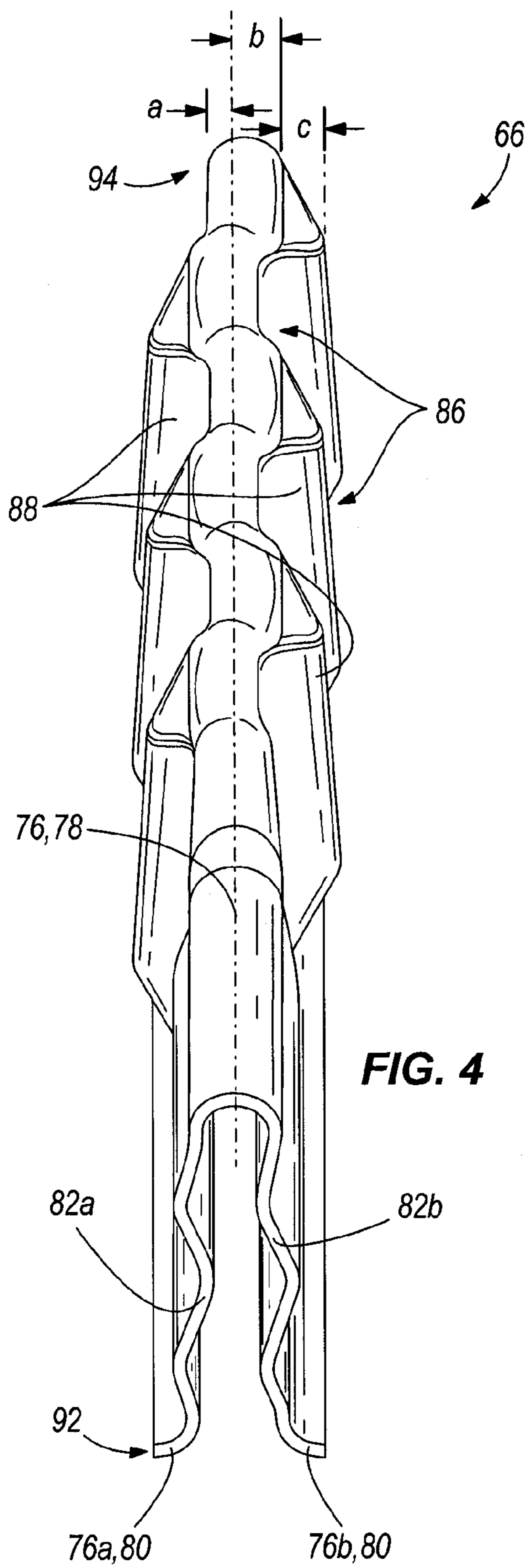

FIG. 2





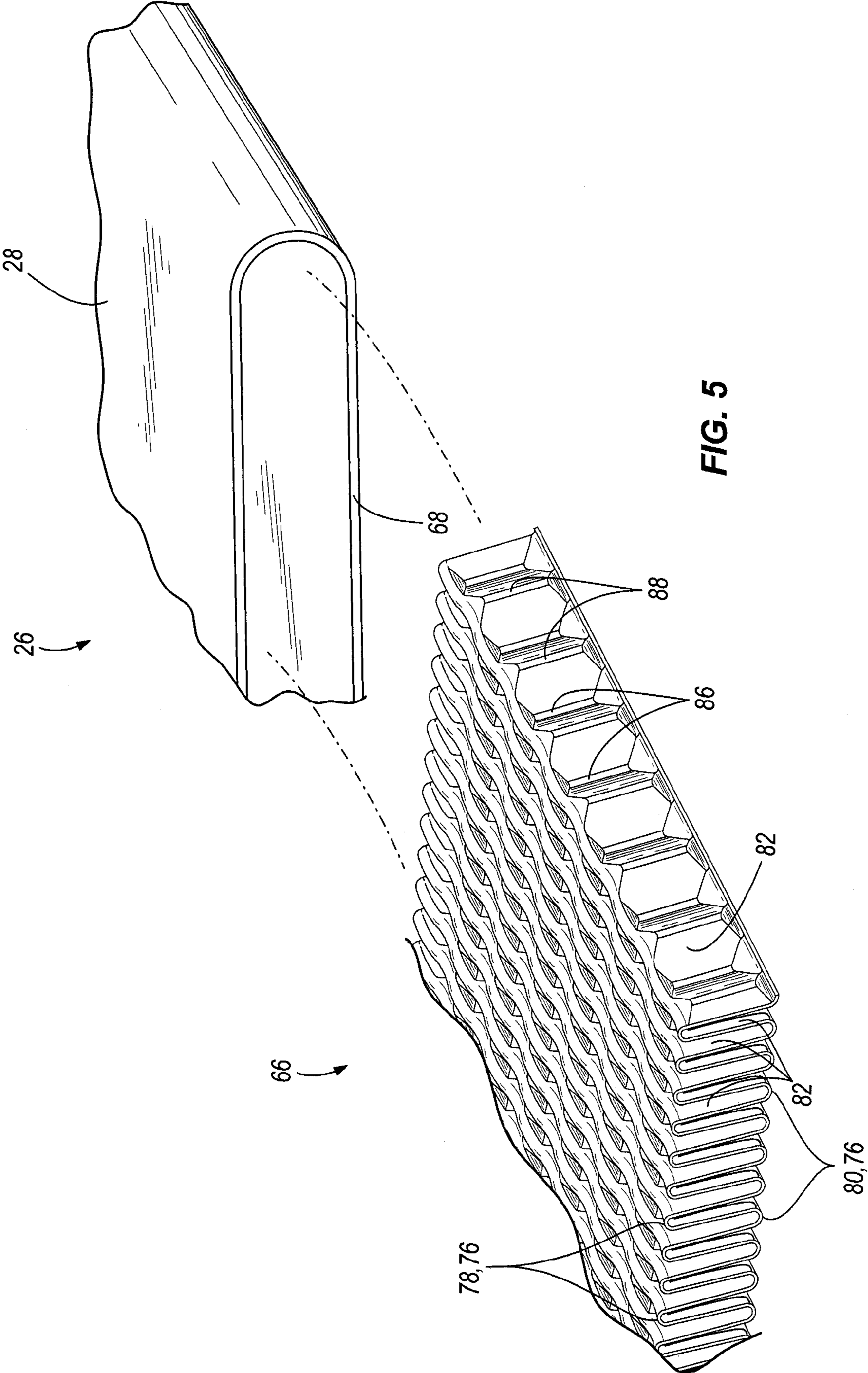

FIG. 5

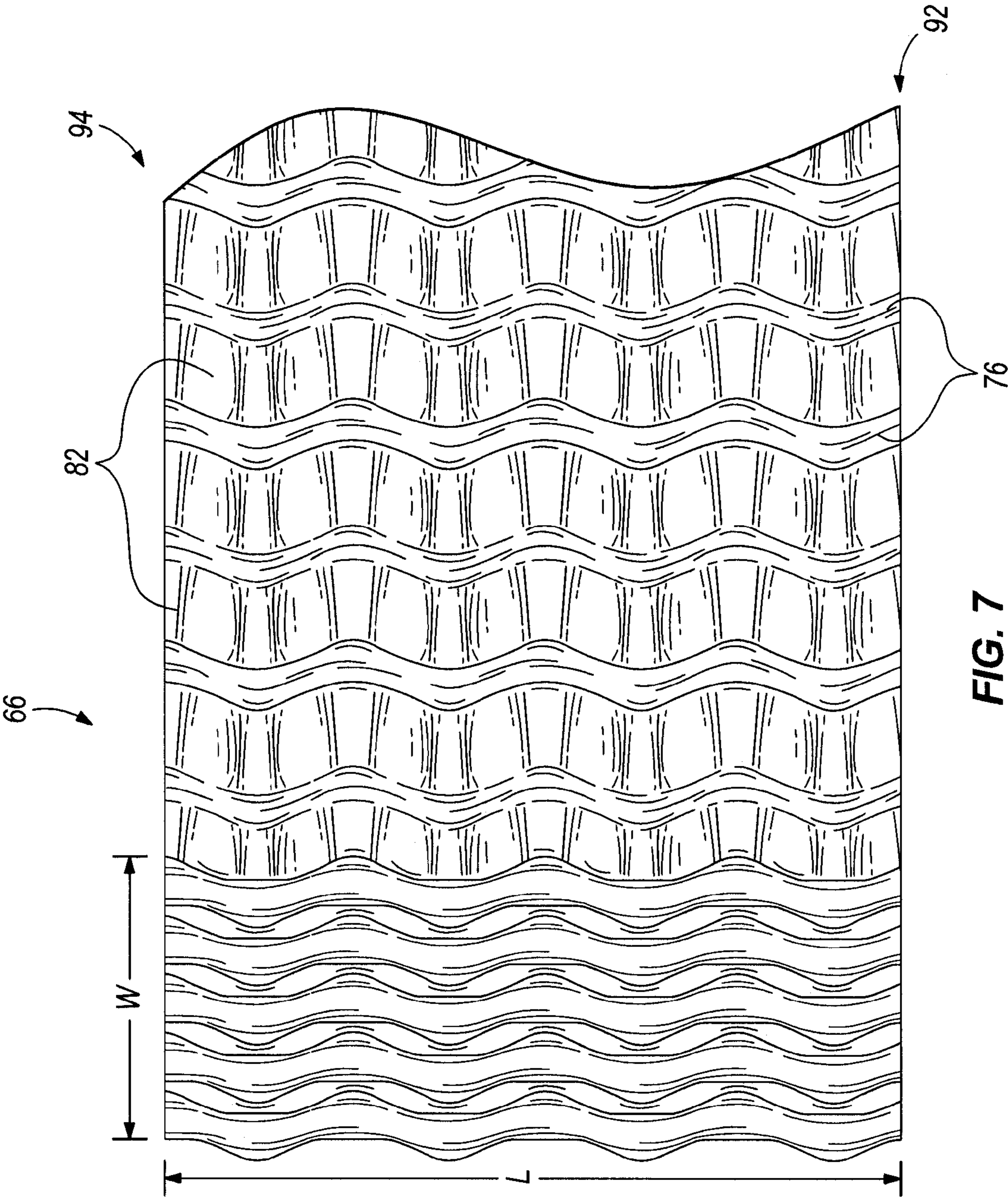

FIG. 7

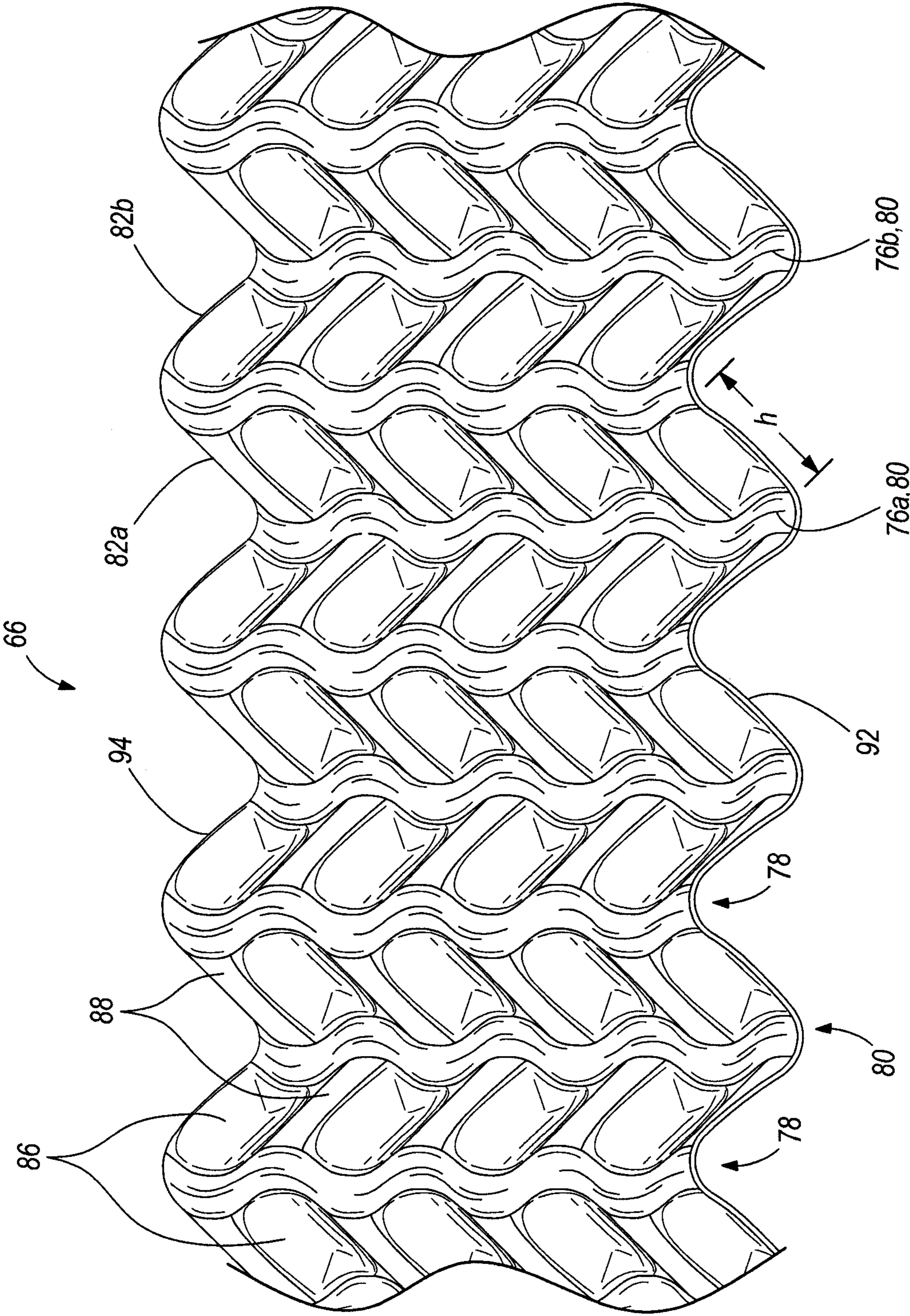

FIG. 8

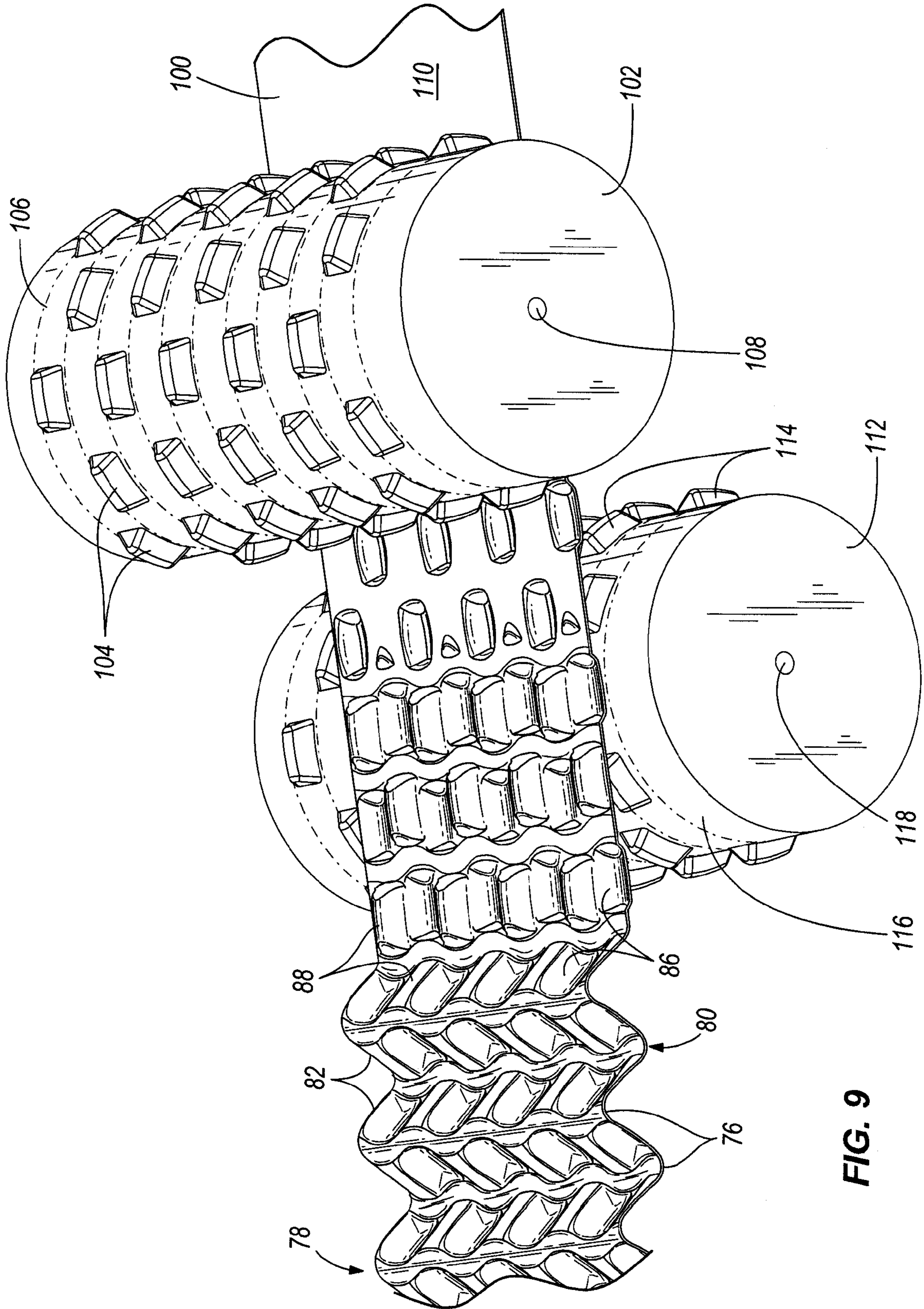

FIG. 9

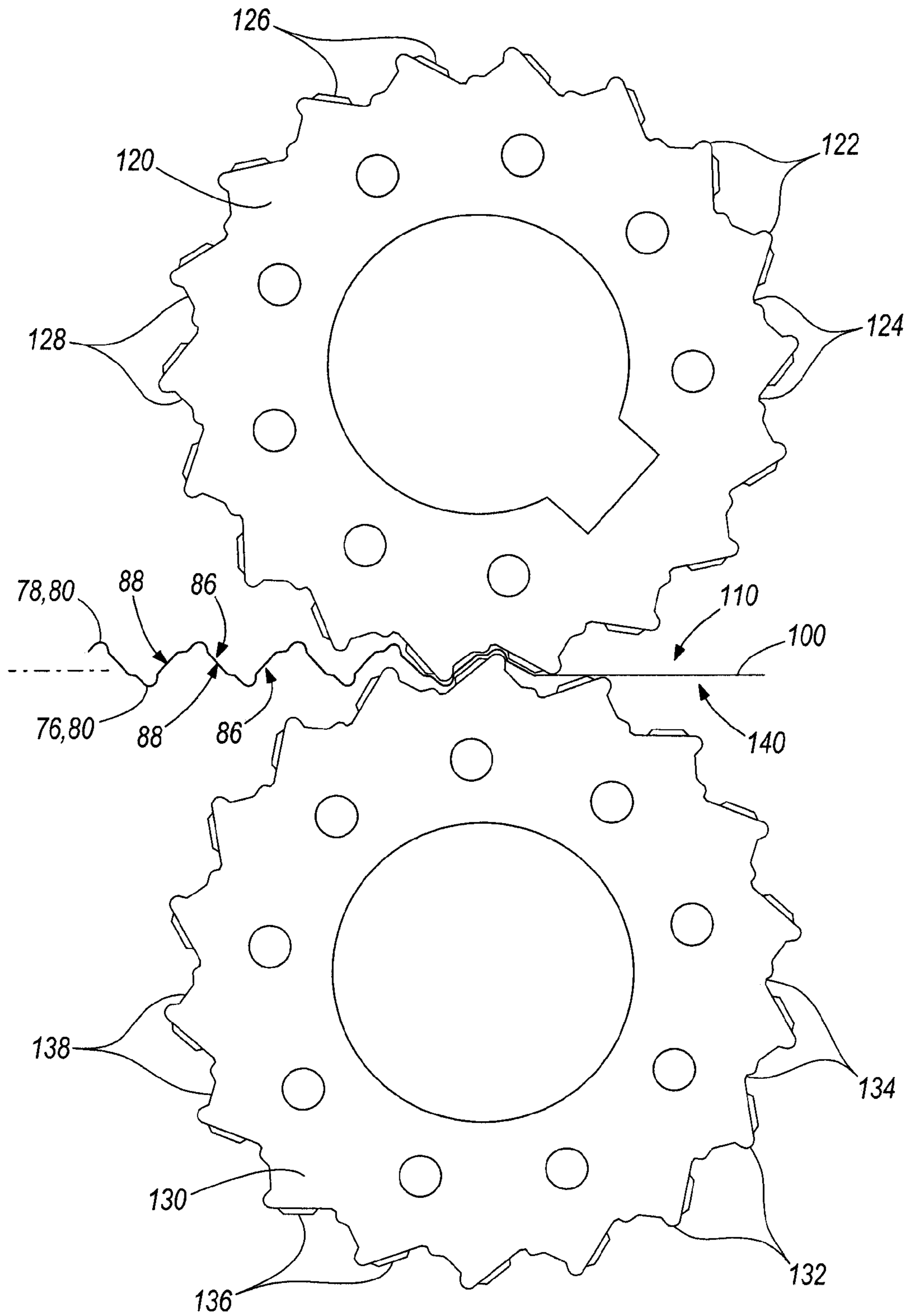

FIG. 10

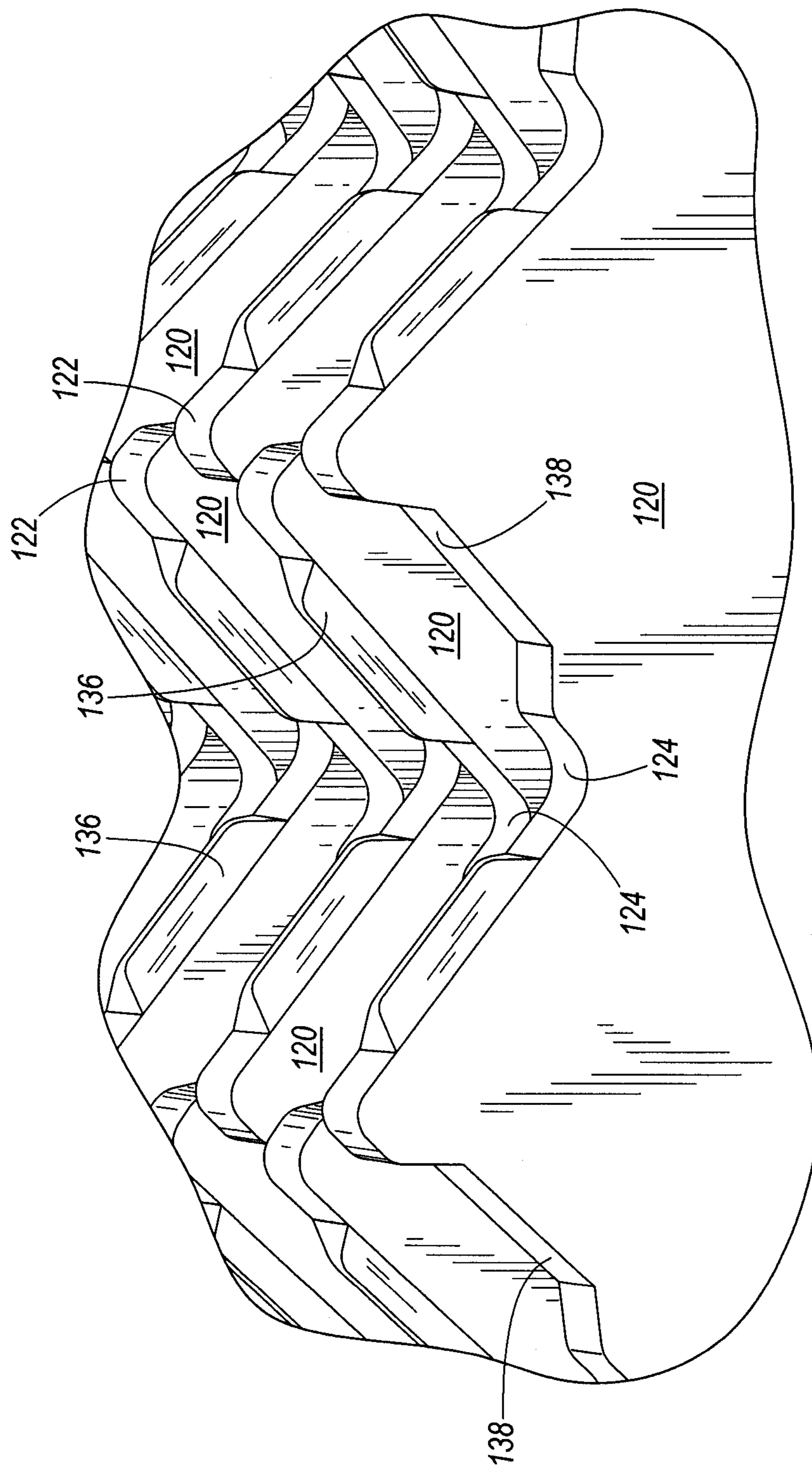
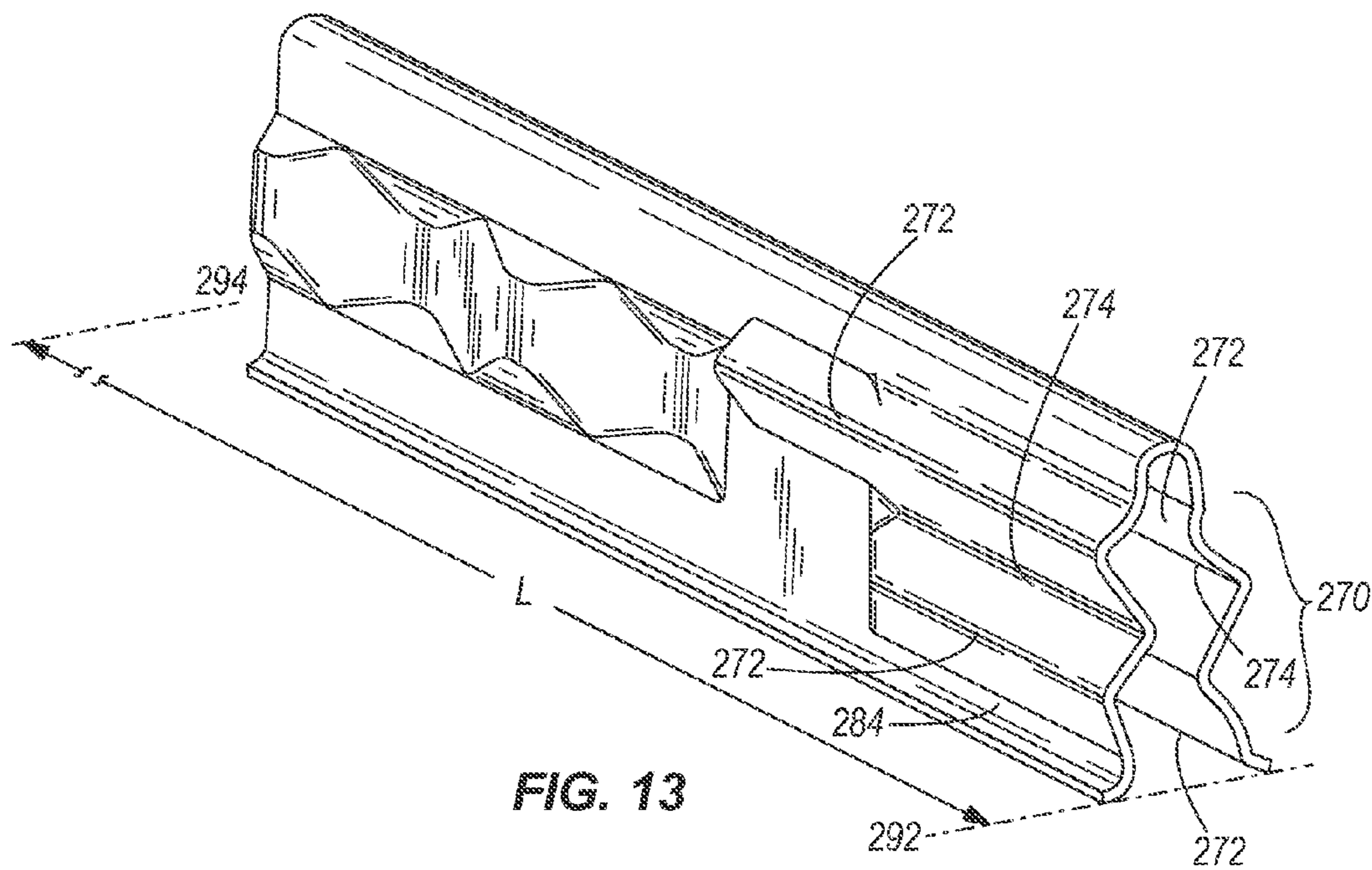
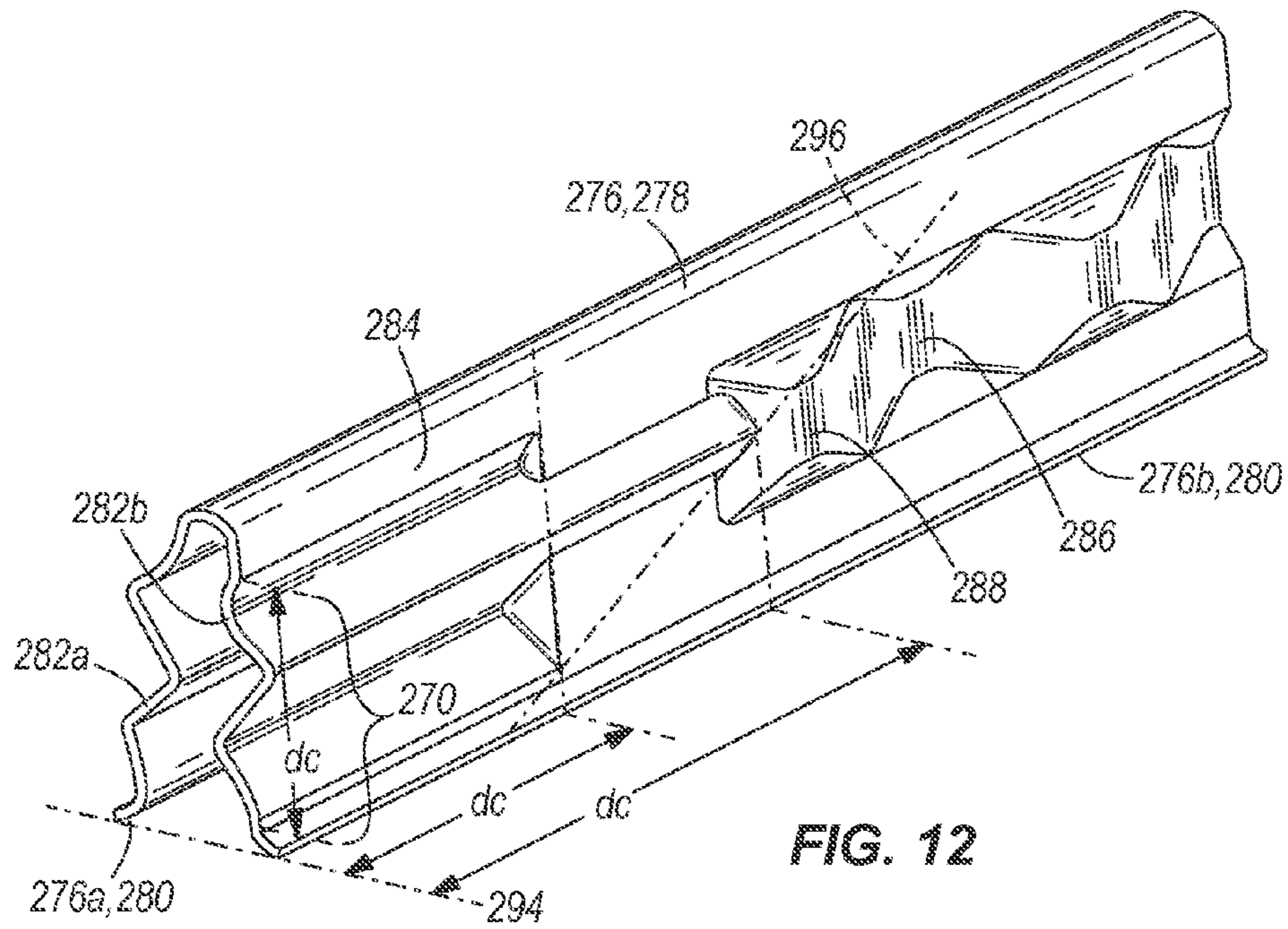

FIG. 11



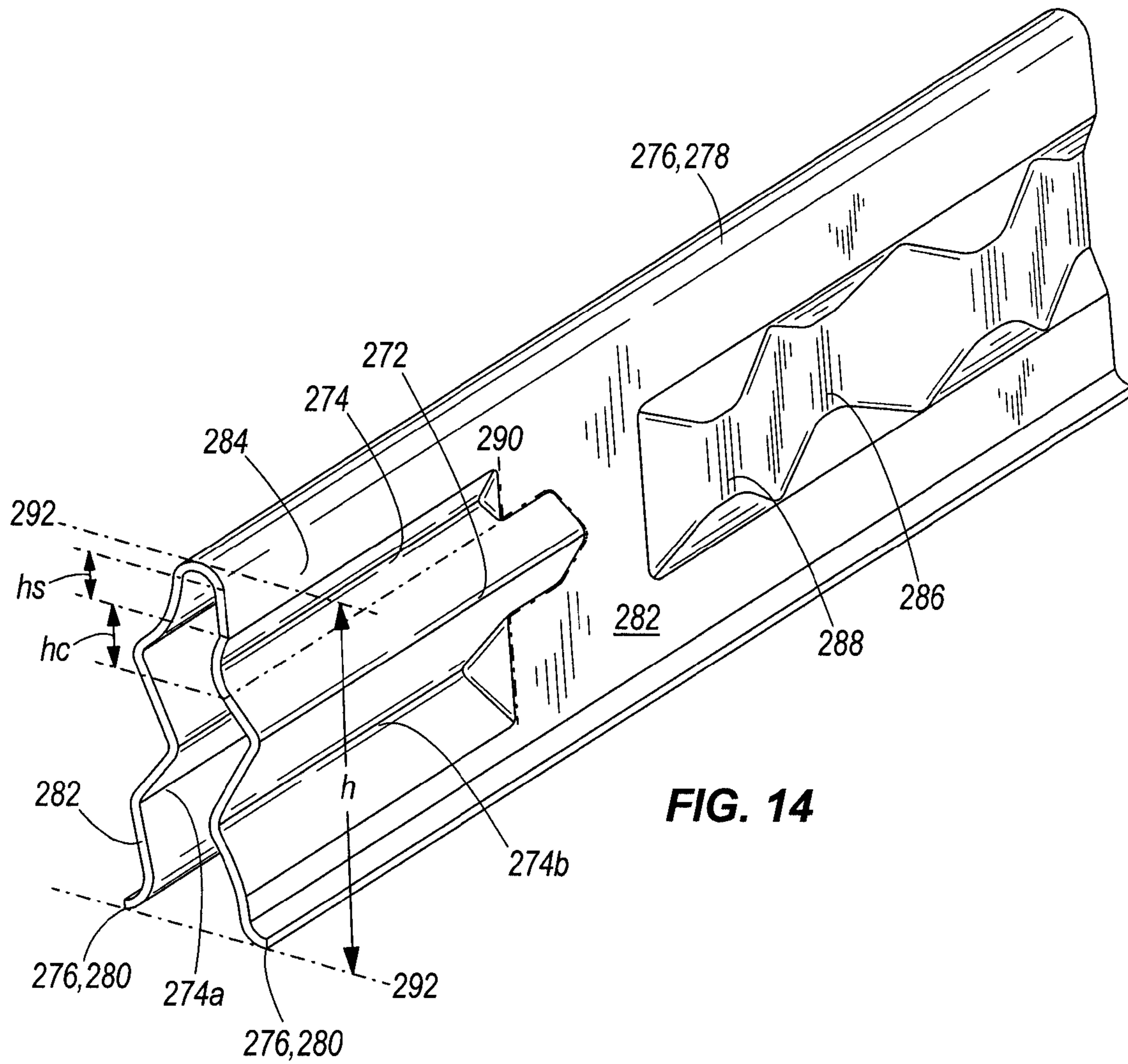

FIG. 14

1

HEAT EXCHANGER HAVING CONVOLUTED FIN END AND METHOD OF ASSEMBLING THE SAME

CROSS-REFERENCE TO RELATED APPLICATIONS

The present application is a continuation-in-part of U.S. patent application Ser. No. 12/061,191, filed Apr. 2, 2008, and is also a continuation-in-part of PCT Patent Application Serial Number PCT/US2008/051747, filed Jan. 23, 2008, which claims priority to U.S. Provisional Application Ser. No. 60/881,919 filed Jan. 23, 2007, the entire contents of which are hereby incorporated by reference.

FIELD OF THE INVENTION

The present invention relates to heat exchangers and more particularly, to a fin for an exhaust gas recirculation cooler and a method of forming the same.

SUMMARY

In some embodiments, the present invention provides a heat exchanger for transferring heat between a first working fluid and a second working fluid. The heat exchanger can include a pair of spaced apart headers, a number of tubes extending between the pair of headers and providing a flow path for the first working fluid and being positioned along a flow path for the second working fluid, and a fin supportable in one of the tubes and having a fold extending in a direction substantially parallel to a length of the one of the tubes between the pair of headers. The fin can include a number of recesses extending into and spaced along the fold.

The present invention also provides a heat exchanger for transferring heat between a first working fluid and a second working fluid including a pair of spaced apart headers, a number of tubes extending between the pair of headers and providing a flow path for the first working fluid and being positioned along a flow path for the second working fluid, and a fin supportable in one of the tubes and having a fold extending in a direction substantially parallel to the flow path for the first working fluid through the tubes. The fold can define first and second legs of the fin. A recess can be formed on the first leg and a protrusion can be formed on the second leg opposite to the recess on the first leg.

In some embodiments, the present invention provides a heat exchanger for transferring heat between a first working fluid and a second working fluid including a pair of spaced apart headers, a number of tubes extending between the pair of headers and providing a flow path for the first working fluid and being positioned along a flow path for the second working fluid, and a fin supportable in one of the tubes and having a serpentine fold extending in a direction substantially parallel to a length of the tube between the pair of headers.

The present invention also provides a heat exchanger for transferring heat between a first working fluid and a second working fluid including a corrugated fin positionable along a flow path of the first working fluid between adjacent tube walls and operable to increase heat transfer between the first working fluid and the second working fluid. The fin can include a leg defined between adjacent folds and a plurality of convolutions extending inwardly from a distal end of the leg and terminating at different distances from the end.

In some embodiments, the present invention provides a corrugated fin for a heat exchanger, the heat exchanger having a flow path of a first working fluid and a flow path of a second

2

working fluid and being operable to transfer heat between the first and second working fluids. The fin can include a leg defined between adjacent folds and positionable along the flow path of the first working fluid and a plurality of convolutions extending inwardly from a distal end of the leg and having different lengths in the direction of the flow of the first working fluid along the flow path.

The present invention also provides a method of forming a heat exchanger for transferring heat between a first working fluid and a second working fluid. The method can include the acts of corrugating a fin to define a plurality of legs and forming a plurality of convolutions along one of the plurality of legs, the plurality of convolutions extending inwardly from a distal end of the leg and terminating at different distances from the end.

Other aspects of the invention will become apparent by consideration of the detailed description and accompanying drawings.

BRIEF DESCRIPTION OF THE DRAWINGS

FIG. 1 is a bottom perspective view of a heat exchanger according to some embodiments of the present invention.

FIG. 2 is a partially cut-away view of a portion of the heat exchanger shown in FIG. 1.

FIG. 3 is an exploded perspective view of a portion of a tube and a fin of the heat exchanger shown in FIG. 1.

FIG. 4 is a perspective view of a portion of the fin shown in FIG. 3.

FIG. 5 is an exploded perspective view of a portion of a tube and a fin according to an alternate embodiment of the present invention.

FIG. 6 is a perspective view of a portion of the fin shown in FIG. 5.

FIG. 7 is a top view of a partially formed fin that can be manufactured according to the method shown in FIG. 9.

FIG. 8 is a perspective view of a partially formed fin that can be manufactured according to the method shown in FIG. 10.

FIG. 9 illustrates a method for forming the fin shown in FIG. 5.

FIG. 10 illustrates another method for forming the fin shown in FIG. 5.

FIG. 11 is a perspective view of a section of the fin forming device shown in FIG. 10.

FIG. 12 is a perspective view of a portion of a heat exchanger fin according to some embodiments of the present invention.

FIG. 13 is a perspective view of a portion of a heat exchanger fin according to some embodiments of the present invention.

FIG. 14 is a perspective view of a portion of a heat exchanger fin according to some embodiments of the present invention.

DETAILED DESCRIPTION

Before any embodiments of the invention are explained in detail, it is to be understood that the invention is not limited in its application to the details of construction and the arrangement of components set forth in the following description or illustrated in the following drawings. The invention is capable of other embodiments and of being practiced or of being carried out in various ways. Also, it is to be understood that the phraseology and terminology used herein is for the purpose of description and should not be regarded as limiting. The use of "including," "comprising," or "having" and varia-

tions thereof herein is meant to encompass the items listed thereafter and equivalents thereof as well as additional items.

Unless specified or limited otherwise, the terms “mounted,” “connected,” “supported,” and “coupled” and variations thereof are used broadly and encompass both direct and indirect mountings, connections, supports, and couplings. Further, “connected” and “coupled” are not restricted to physical or mechanical connections or couplings.

Also, it is to be understood that phraseology and terminology used herein with reference to device or element orientation (such as, for example, terms like “central,” “upper,” “lower,” “front,” “rear,” and the like) are only used to simplify description of the present invention, and do not alone indicate or imply that the device or element referred to must have a particular orientation. In addition, terms such as “first” and “second” are used herein for purposes of description and are not intended to indicate or imply relative importance or significance.

FIGS. 1-4 illustrate a heat exchanger 10 according to some embodiments of the present invention. In some embodiments, including the illustrated embodiments of FIGS. 1-4, the heat exchanger 10 can operate as an exhaust gas recirculation cooler (EGRC) and can be operated with the exhaust system and/or the emission system of a vehicle. In other embodiments, the heat exchanger 10 can be used in other (e.g., non-vehicular) applications, such as, for example, in electronics cooling, industrial equipment, building heating and air-conditioning, and the like. In addition, it should be appreciated that the heat exchanger 10 of the present invention can take many forms, utilize a wide range of materials, and can be incorporated into various other systems.

During operation and as explained in greater detail below, the heat exchanger 10 can transfer heat from a high temperature first working fluid (e.g., exhaust gas, water, engine coolant, CO₂, an organic refrigerant, R12, R245fa, air, and the like) to a lower temperature second working fluid (e.g., water, engine coolant, CO₂, an organic refrigerant, R12, R245fa, air, and the like). In addition, while reference is made herein to transferring heat between two working fluids, in some embodiments of the present invention, the heat exchanger 10 can operate to transfer heat between three or more fluids. Alternatively or in addition, the heat exchanger 10 can operate as a recuperator and can transfer heat from a high temperature location of a heating circuit to a low temperature location of the same heating circuit. In some such embodiments, the heat exchanger 10 can transfer heat from a working fluid traveling through a first portion of the heat transfer circuit to the same working fluid traveling through a second portion of the heat transfer circuit.

As shown in FIGS. 1 and 2, the heat exchanger 10 can include a first header 18 and a second header 20 positioned at respective first and second ends 22, 24 of a stack of heat exchanger tubes 26 having outer surfaces 28 (shown in FIGS. 1, 3, and 5). In the illustrated embodiment of FIGS. 1-4, the first end 22 is secured to a first collecting tank 30 and the second end 24 is secured to a second collecting tank 32. In other embodiments, the heat exchanger 10 can include a single header 18 and/or a single tank 30 located at one of the first and second ends 22, 24 or at another location on the heat exchanger 10.

As shown in FIGS. 1 and 2, each of the tubes 26 can be secured to the first and second headers 18, 20 such that a first working fluid flowing through the heat exchanger 10 is maintained separate from a second working fluid flowing through the heat exchanger 10. More specifically, the heat exchanger 10 defines a first flow path (represented by arrows 34 in FIG. 1) for the first working fluid and a second flow path (repre-

sented by arrows 36 in FIG. 1) for a second working fluid, and the first and second flow paths 34, 36 are separated such that the first working fluid is prevented from entering the second flow path 36 and such that the second working fluid is prevented from entering the first flow path 34.

In some embodiments, such as the illustrated embodiment, the tubes 26 are secured to the first and second headers 18, 20 and the first and second tanks 30, 32 such that the first working fluid enters the heat exchanger 10 through a first inlet aperture 40 in the first tank 30, travels through the tubes 26 of the heat exchanger 10 along the first flow path 34, and is prevented from entering the second flow path 36. In these embodiments, the tubes 26 can be secured to the first and second headers 18, 20 and the first and second tanks 30, 32 such that the second working fluid enters the heat exchanger 10 through a second inlet aperture 42 in the second tank 32, travels through the heat exchanger 10 along the second flow path 36 between the tubes 26, and is prevented from entering the first flow path 34.

In other embodiments, the tubes 26 can have other orientations and configurations and the first and second flow paths 34, 36 can be maintained separate by dividers, fins, partitions, and the like. In still other embodiments, the first flow path 34 can extend through some of the tubes 26 while the second flow path 36 can extend through other tubes 26.

As shown in FIG. 2, the headers 18, 20 can have apertures sized to receive one or more of the tubes 26. As illustrated by FIGS. 1 and 2, the first working fluid flowing along the first flow path 34 can enter the tubes 26 through apertures formed in the first header 18. In these embodiments, the first header 18 can also direct the second working fluid from the second inlet aperture 42 between adjacent tubes 26 and can prevent the second working fluid from flowing into the tubes 26. The first header 18 can also prevent the first working fluid from flowing between the tubes 26.

In the illustrated embodiment, the heat exchanger 10 is configured as a cross-flow heat exchanger such that the first flow path 34 or a portion of the first flow path 34 is opposite to the second flow path 36 or a portion of the second flow path 36. In other embodiments, the heat exchanger 10 can have other configurations and arrangements, such as, for example, a parallel-flow or a counter-flow configuration.

In the illustrated embodiment, the heat exchanger 10 is configured as a single-pass heat exchanger with the first working fluid traveling along the first flow path 34 through at least one of a number of tubes 26 and with the second working fluid traveling along the second flow path 36 between adjacent tubes 26. In other embodiments, the heat exchanger 10 can be configured as a multi-pass heat exchanger with the first working fluid traveling in a first pass through one or more of the tubes 26 and then traveling in a second pass through one or more different tubes 26 in a direction opposite to the flow direction of the first working fluid in the first pass. In these embodiments, the second working fluid can travel along the second flow path 36 between adjacent tubes 26.

In yet other embodiments, the heat exchanger 10 can be configured as a multi-pass heat exchanger with the second working fluid traveling in a first pass between a first pair of adjacent tubes 26 and then traveling in a second pass between another pair of adjacent tubes 26 in a direction opposite to the flow direction of the second working fluid in the first pass. In these embodiments, the first working fluid can travel along the first flow path 34 through at least one of the tubes 26.

In the illustrated embodiment, the heat exchanger 10 includes seven tubes 26, each of which has a substantially rectangular cross-sectional shape. In other embodiments, the heat exchanger 10 can include one, two, three, four, five, six,

5

eight, or more tubes **26**, each of which can have a triangular, circular, square or other polygonal, oval, or irregular cross-sectional shape.

As mentioned above, in some embodiments, the second flow path **36** or a portion of the second flow path **36** can extend across the outer surface **28** of one or more of the tubes **26**. In some such embodiments, ribs **56** (see FIG. 3) can be formed along the outer surfaces **28** of the tubes **26** to at least partially define channels **58** between adjacent tubes **26**. Alternatively, as shown in FIG. 5, the tubes **26** of the heat exchanger **10** can be generally oval shaped (i.e., a simple extruded tube) and devoid of ribs **56** defining channels **58**. A housing can be provided around the tubes **26** to prevent the second fluid from leaking out of the heat exchanger **10** between adjacent tubes **26**. In such an embodiment, the housing would define the second flow path **36** between/around the tubes **26**.

In embodiments, such as the illustrated embodiment of FIGS. 1-4, having outwardly extending ribs **56**, the ribs **56** of each tube **26** can be secured to an adjacent tube **26**. In some such embodiments, the ribs **56** of one tube **26** can be soldered, brazed, or welded to an adjacent tube **26**. In other embodiments, adjacent tubes **26** can be secured together with inter-engaging fasteners, other conventional fasteners, adhesive or cohesive bonding material, by an interference fit, etc. In addition, a housing can be provided around the tubes **26** of the embodiment illustrated in FIGS. 1-4.

Additional elevations, recesses, or deformations **64** can also or alternatively be provided on the outer surfaces **28** of the tubes **26** to provide structural support to the heat exchanger **10**, prevent the deformation or crushing of one or more tubes **26**, maintain a desired spacing between adjacent tubes **26**, improve heat exchange between the first and second working fluids, and/or generate turbulence along one or both of the first and second flow paths **34**, **36**.

The heat exchanger **10** can include fins **66**, which improve heat transfer between the first and second working fluids as the first and second working fluids travel along the first and second flow paths **34**, **36**, respectively. The fins **66** can provide the heat exchanger core (i.e., the tubes **26**) with increased surface area for distribution of the heat provided by the first and/or second working fluids. As shown in FIGS. 2, 3, and 5, the fins **66** can be positioned in the tubes **26**. Alternatively or in addition, fins **66** can be positioned between adjacent tubes **26**. In other embodiments, fins **66** can be integrally formed with the tubes **26** and can extend outwardly from the outer surfaces **28** of the tubes **26**, or alternatively, inwardly from inner surfaces **38** of the tubes **26**. In some embodiments, the fins **66** can improve the durability and strength of the heat exchanger **10**. The configurations (geometrical and topographical) of the fins **66** can be such that the expansion and contraction experienced by the material due to thermal fluctuations can be compensated for with increased flexibility (discussed in further detail below).

In the illustrated embodiment of FIG. 2, a fin **66** is supported in each of the tubes **26**, and extends along the entire length or substantially the entire length of each of the tubes **26** between opposite ends **68** of the tubes **26**. As FIG. 2 illustrates, the fin **66** can also or alternatively extend across the entire width or substantially the entire width of each of the tubes **26** between opposite sides of the tubes **26**. In other embodiments, a fin **26** can be supported in only one or less than all of the tubes **26**, and the fin(s) **66** can extend substantially the entire length of the tube(s) **26** between opposite ends **68** of the tube(s) **26**, or alternatively, the fin(s) **66** can extend through the tube(s) **26** along substantially less than the entire length of the tube(s) **26**. In still other embodiments, two or more fins **66** can be supported by or in each tube **26**. In some

6

embodiments, the fins **66** can be secured to the tubes **26**. In some such embodiments, the fins **66** are soldered, brazed, or welded to the tubes **26**. In other embodiments, the fins **26** can be connected to the tubes **26** in another manner, such as, for example, by an interference fit, adhesive or cohesive bonding material, fasteners, etc.

In some embodiments, the ends **68** of the tubes **26** can be press-fit into one or both of the first and second headers **18**, **20**. In some such embodiments, the ends **68** of the tubes **26** and the fins **66** supported in the tubes **26** or between the tubes **26** can be at least partially deformed when the tubes **26** and/or the fins **66** are press-fit into the first and/or second headers **18**, **20**. As such, the tubes **26** and/or the fins **66** are pinched and maintained in compression to secure the tubes **26** and/or the fins **66** in a desired orientation and to prevent leaking. In some embodiments, the tubes **26** can be brazed, soldered, or welded to the first and/or second headers **18**, **20**.

In the illustrated embodiments, roll-formed sheets of metal are folded to form the fins **66** in a method that will be described in further detail below. In other embodiments, the fins **66** can be cast or molded in a desired shape and can be formed from other materials (e.g., aluminum, copper, iron, and other metals, composite material, alloys, and the like). In still other embodiments, the fins **66** can be cut or machined to shape in any manner, can be extruded or pressed, can be manufactured in any combination of such operations, and the like.

As most clearly shown in FIGS. 3 and 7, the fin **66** can be corrugated and have an overall length L , width W , and height H . The length L of the fin **66** is defined as the general direction of fluid flow within the tube **26** (i.e., from the first header **18** to the second header **20**). As shown in the embodiment illustrated in FIG. 3, each fold forms a serpentine spine **76** that extends generally in parallel to the length L of the fin **66**.

The illustrated embodiment of the fin **66** includes a series of parallel-running spines **76** that form alternating peaks **78** and valleys **80** along the width W of the fin **66**. As shown in FIG. 2, the peaks **78** and valleys **80** can engage respective upper and lower interior sides (e.g., between upper and lower sides in FIGS. 2, 3, and 5) of a tube **26**. In the illustrated embodiment, legs or flanks **82** extend between each pair of adjacent folds (i.e., from a peak **78** to a valley **80** or vice versa) along the length L , to give the fin **66** a height H . In addition, the fins **66** of some embodiments can have pointed, squared, or irregularly shaped peaks **78** and/or valleys **80**. The resulting lateral edge of the fin **66** of the illustrated embodiment, as shown in FIGS. 2 and 3 can be generally wavy. However, in other embodiments, the lateral edge can be generally sinusoidal or saw-toothed, among other shapes. The structural elements formed by each fold **76** of the corrugated fin **66** are described more specifically with reference to FIGS. 4 and 6 below.

As illustrated by FIGS. 4 and 6, a first leg **82a** can be at least partially defined on one side of a spine **76** and a second leg **82b** can be at least partially defined on the other side of the spine **76**. Fold **76a** is positioned immediately adjacent to the first leg **82a** and defines a height h of the leg **82a**. Similarly, fold **76b** is positioned at the distal end of the second leg **76b**, which has the same height h . The space S between adjacent legs **82a**, **82b** is defined as the distance between the points located at the same distance along length L and height h of each leg **82**. The legs **82** of the fin **66** can also have various topographical configurations. For example, at one point along the length L , the legs **82** can be convoluted or wavy (i.e., when viewed from an end of the fin **66**, and at another point along the length L , the legs **82** can be straight.

As shown in FIGS. 3-8, the legs 82 can include contour elements such as recesses 86 and protrusions 88 spaced along their length L. These elements are deformations in the material that forms the fin 66 and do not pierce or provide connections between opposite sides of the fin 66. In some such 5 embodiments, a recess 86 formed on one side of a leg 82 can consequently form a protrusion 88 on the opposite side of the leg 82 (i.e., a recess 86 is a geometric complement of protrusion 88). The contour elements formed in the fin 66 can appear as pyramid, frustum, prism, and/or hemispheroid-like 10 projections or recesses, among others. In the illustrated embodiment, the contour elements each have two planes of symmetry (one of which is the length L, space s plane, and the other of which is the height h, space s plane). As such, the upper half of the contour element is a mirror image of the 15 bottom half (with respect to the height h of the leg 82 it is positioned on). Similarly, the left half of the contour element is a mirror image of the right half (with respect to the length L of the leg 82 it is positioned on). In some embodiments, a protrusion 86 in one leg 82a can be positioned such that it is at least partially receivable in a recess 88 in an adjacent leg 82b (i.e., at the same distance along height h and length L of each leg).

In some embodiments, contour elements can extend along the entire height h of the leg 82 from one fold 76 to an adjacent 25 fold 76 (i.e., from a peak 78 to an adjacent valley 80 or vice versa). Each contour element has a width d, as shown in FIG. 6. In the illustrated embodiment, the width d also indicates the spacing between similar contour elements. In other embodiments, the spacing between similar contour elements can be 30 greater than the width d of an intervening or alternating contour element.

As shown in FIG. 4, the serpentine shape of the spine 76 is determined by the geometry and placement of the recesses 86 and protrusions 88. In the illustrated embodiments, recesses 86 are alternated with protrusions 88 along the length L of each leg 82, and each of the contours extends between adjacent 35 folds 76. Accordingly, a number of recesses 86 and a number of protrusions 88 can be spaced along the edge of each fold 76. FIG. 4 includes reference measurements to more clearly illustrate the geometry of the fin 66. Specifically, reference a indicates the distance between the midline of the fold 76 and the edge of a recess 86, reference b indicates the distance between the midline of the fold 76 and the edge of a 40 protrusion 88, and reference c indicates the lateral distance (i.e., the direction normal to the length L of the fin and width d of the contour element) from the edge of the contour element at the fold 76, to its outermost point/extension.

As illustrated in FIGS. 3-6, a fin 66 formed with longitudinal rows of alternating contour elements 86, 88, can be 50 folded such that the space S between adjacent legs 82 at a particular height h can be generally constant along their length L. Thus, the flow path cross-sectional area is essentially constant along the length L between opposite ends 68 of the tube 26. Accordingly, the first flow path 34 is made circuitous and is consequently longer than a straighter flow path. Such a fin configuration can increase turbulence of the working fluid and consequently allow for more efficient heat transfer without causing significant pressure changes/buildup along the length L of the fin 66. Additionally, contour elements formed in the fins 66 can impact the shape of the spine 76. For example, FIGS. 3-8 show how a pattern of recesses 86 and protrusions 88—specifically longitudinal rows of the continuously alternating contour elements—can create a serpentine-shaped spine 76. As such, even the flow path immediately adjacent to the inner surfaces 38 of the tube 26 is elongated and made circuitous. The serpentine shape of the

spine 76 can also provide a reinforced connection between the tube 26 and the fin 66 which can also improve heat transfer.

In embodiments having fins 66 with wavy or contoured cross-sections, such as the illustrated embodiments, the fins 66 operate as elastic members to absorb or at least partially 5 absorb vibrations and/or to absorb expansions and contractions of the fins 66 caused by fluctuating temperatures of the first and/or second working fluids. In some such embodiments, the elasticity of the contoured fins 66 prevents or 10 reduces cracking and breaking of the fins 66. Alternatively or in addition, the elasticity of the contoured fins 66 prevents and/or reduces cracking and breaking of connections (e.g., solder points, braze points, weld points, etc.) between the spines 76 of the fins 66 and the interior sides of the tubes 26.

As shown in FIGS. 5-8, in some embodiments, contours 86, 88 can extend continuously from a first lateral edge 92 to a second lateral edge 94, along the length L of a leg 82. In other embodiments, such as those illustrated in FIGS. 2-4, contours only extend continuously along the length L of a 20 middle portion of the fin 66, while the edges 92, 94 have a different topographical configuration. For example, as shown in the embodiments of FIGS. 3 and 4, the convolutions of the fin 66 can start at a lateral edge 92 of a fin 66 and extend along the length L of the fin 66 a common distance, dc. In some 25 embodiments, the convolutions can extend from a lateral edge of the fin 66 to a point beyond the connection plane of the header 18, with the stack of tubes 26. The contoured portion can allow for changes in length L (i.e., longitudinal flexibility), while the convoluted edges can compensate for changes 30 in height h of the legs 82 (i.e., vertical flexibility). This can be desirable in embodiments where the height of the fin H is constrained by connection to the inner surfaces 38 of the tube 26, especially where the tube ends 68 are further constrained by the first and second headers 18, 20.

FIGS. 12-14 represent an alternate embodiment of a heat exchanger fin 266 according to the present invention. The portion of a heat exchanger fin 266 shown in FIGS. 6 and 7 is similar in many ways to the illustrated embodiments of FIGS. 1-8 described above. Accordingly, with the exception of 40 mutually inconsistent features and elements between the embodiment of FIGS. 12-14 and the embodiments of FIGS. 1-8, reference is hereby made to the description above accompanying the embodiments of FIGS. 1-8 for a more complete description of the features and elements (and alternatives and/or additions to the features and elements) of the embodiment of FIGS. 12-14. Features and elements in the embodiment of FIGS. 12-14 corresponding to features and elements in the embodiments of FIGS. 1-8 are numbered in the 200 series.

As illustrated in FIGS. 12-14, fin 266 can have convolutions 270 extending from the lateral edges 292, 294 a distance, dc (i.e., parallel to length, L) along the leg 282 of the fin 266, in a direction parallel to the folds 276 that define the leg 282. In other embodiments, convolutions 270 can be positioned along the fin 266 at a location that is not immediately 55 adjacent a lateral edge 292, 294. Any number of convolutions 270 can be provided on a portion of leg 282, and the number of convolutions 270 can be consistent or vary from leg portion to leg portion (and/or from lateral edge 292 to lateral edge 294, and/or from fin 266 to fin 266, etc.). In addition, the geometrical shape of the convolutions 270 can vary from rounded to pointed. The number of differing shape convolutions 270 can be consistent or vary from leg portion to leg portion (and/or from lateral edge 292 to lateral edge 294, and/or from fin 266 to fin 266, etc.). Further, as shown in the illustrated embodiment of FIG. 14, the height, hc of each 65 convolution, the total convoluted height, cc (see FIG. 12) on

a particular leg **282**, and the height, h_s of any space (area lying in the plane of leg **282**) between convolutions **270** can be consistent or vary from leg portion to leg portion (and/or from lateral edge **292** to lateral edge **294**, and/or from fin **266** to fin **266**, etc.).

Convolutions **270** can include beads **272** and dimples **274** that alternate along the height h of the fin **266**. In general, a bead **272** is a convolution **270** projecting in one direction from the plane of a leg **282** (defined by a point adjacent each of the folds defining the leg and one other point on the leg **282**), while a dimple **274** is a convolution projecting in the opposite direction from the plane of a leg **282**. In order to clarify the following explanation, the following naming convention will be followed: when the surface of any particular leg **282** is viewed, beads **272** will extend away from the viewer while dimples **274** will extend toward the viewer. As such, it should be understood that two or more dimples **274** could be positioned adjacent each other (as could two or more beads **272**).

FIGS. **12-14** illustrate that convolutions **270** on a single leg **282** can extend varying distances, d_c along the length L of the fin **266**. For example, in FIG. **12**, the uppermost convolution, dimple **274**, extends from lateral edge **292** of the fin **266** a distance, d_c less than the adjacent convolution, bead **272** (immediately below the uppermost convolution). Further, two non-adjacent convolutions **290** can extend the same distance, d_c (i.e., have the same length)-dimples **274** in FIG. **12** or dimple **274** and bead **272** in FIG. **13** for example. In other embodiments two or more adjacent convolutions **270** can extend the same distance, d_c along the length L of the leg. In addition, the lengths of corresponding convolutions **270** (i.e., convolutions at the same height h —for example, **274a** and **274b** in FIG. **14**) on adjacent legs **282** can be different or similar depending on the embodiment of the invention.

Alternatively or in addition, convolutions **270** can extend to different endpoints with respect to contour elements **286**, **288**. For example, in FIG. **12**, the middle convolution, bead **272**, extends from lateral edge **292** of the fin **266** into the protrusion **288** most proximal to the lateral edge **292**. In such embodiments, adjacent ends of two of the convolutions **270** are oriented along, or intersected by, a line **296** which is non-perpendicular to the flow of working fluid along the flow path. As illustrated in the embodiment of FIG. **13**, the uppermost convolution, bead **272**, extends the farthest of all the convolutions on leg **282a** and terminates immediately adjacent the contour element, recess **286**. As illustrated in the embodiment of FIG. **14**, the middle convolution **270** extends to an end point a distance away from the protrusion **288** most proximal to lateral edge **292**.

In some embodiments of the present invention, spaces **284** (area lying in the plane of leg **282**) can be provided between convolutions **270** and/or between a convolution **270** and a fold **276**. As illustrated in FIG. **12**, space **284** is provided between the uppermost dimple **274** and peak **278**. In another example illustrated in FIG. **13**, space **284** is provided between the lowermost bead **272** and valley **280**.

It should be understood that any of the features or elements described above, particularly but not exclusively with respect to convolutions **270**, can be provided on any, all, or none of the fins **266** in a heat exchanger **210** and/or the portions of a heat exchanger fin **266** (leg **282**, fold **276**, lateral edge **292**, **294**, etc.). Further, convolutions **270** can be provided on fins **266** having through-holes and/or cut outs in the leg **282** of the fin **266** (such as disclosed in U.S. patent application Ser. No. 11/367,611, hereby incorporated by reference), alternatively or in addition to contour elements **286**, **288**. Contour elements **286**, **288** can, in some embodiments, be isolated from (i.e., not extend into) the folds **276** of the fin **266** as shown in FIGS.

12-14. Still further, convolutions **270** can be provided on the legs of fins **266** having louvers, slits or notches (such as disclosed in U.S. patent application Ser. No. 11/015,159), a combination of such features, and/or having no contour elements **286**, **288** at all.

In embodiments having fins **266** with convolutions **270**, such as the illustrated embodiments of FIGS. **3**, **4**, and **12-14**, the fins **266** operate as elastic members to absorb or at least partially absorb vibrations and/or to absorb expansions and contractions of the fins **266** caused by fluctuating temperatures of the first and/or second working fluids. In some such embodiments, the elasticity of the contoured fins **266** in the region of the convolutions prevents or reduces cracking and breaking of the fins **66** and/or cracking and breaking of connections (e.g., solder points, braze points, weld points, etc.) between the spines **276** of the fins **266** and the interior sides of the tubes **226**. Further, in the case that cracking does occur in such embodiments, a staggered profile **290** (see FIG. **14**) where the convolutions **270** terminate along the height h of the leg (distal from the lateral edges **292**, **294** of the fin **266**) can force the crack to propagate a longer distance (in some cases following the profile **290**) toward the connection points of the fin **266** with inner surfaces **238** of the tube **226** which can take longer to occur, thus extending the functional life of the heat exchanger **210**. Alternatively or in addition, a varied staggered profile **290** of convolutions **270** adjacent legs **282** can cause cracks to propagate toward the inner surfaces **238** of the tube **226** at different positions along the length L of the tube, reducing the tendency of the tube itself to crack (and/or the extent of cracking), thereby preserving the isolation of first and second flow paths **234**, **236** and extending the functional life of the heat exchanger **210**.

FIG. **9** illustrates a method of forming a fin **66** for a heat exchanger **10** according to some embodiments of the present invention. The method involves roll-forming a pattern of recesses **86** and protrusions **88** into a sheet of deformable heat conducting material **100** (e.g. aluminum, copper, bronze, and alloys including one or more of these metals). To clarify the description, the process of contour formation is shown in FIG. **9** (and discussed with reference to FIG. **9**) as occurring in two distinct and consecutive steps for a particular longitudinally-located, lateral section of the sheet. First, at the right-hand side of the figure, recesses **86** are roll-formed, then, to the left of that, protrusions **88** are roll-formed. However, in practice, roll-formation of recesses **86** and protrusions **88** can be executed simultaneously (as described and illustrated with respect to the alternative embodiments shown in FIGS. **10** and **11** below). Whether the recesses **86** and protrusions **88** are formed consecutively or simultaneously, the roll-formed fin **66** in FIG. **9** then undergoes a folding process (right-hand side of the figure) to create spines **76**. The steps discussed above can be incorporated into a high-speed assembly process which is described in more detail below.

As shown in FIG. **9**, the method can make use of a first cylindrically-shaped roller **102** having projections **104** positioned in longitudinal rows along its curved exterior surface **106**. The first roller **102** can be rotated about its axis **108** as it makes contact with a first side **110** of the sheet of deformable material **100**, positioned tangentially with respect to the curved surface **106**. The weight of the first roller **102** can be used to exert pressure on the deformable material such that the projections **104** form recesses **86** in the material **100**. In other embodiments, the sheet of material **100** can be forced into contact with the roller **100** by other means to form recesses **86**.

The shape and size of the projections **104** with respect to the thickness of the sheet of material **100** can be such that the

11

recesses **86** formed by contact of projections **104** with the first side **110** of the sheet of deformable material **100** create their geometric complement on a second side (not visible) of the sheet **100** which is opposite to the first side **110**. Thus, recesses **86** and protrusions **88** can be simultaneously formed on the first side **110** and an opposite second side of the sheet **100**, respectively.

A second cylindrically-shaped roller **112** having projections **114** positioned in longitudinal rows along its curved surface **116** can be positioned adjacent to the opposite side of the sheet **100** from the first roller **102**. The second roller **112** can also be rotated about its axis **118** as it makes contact with the second side of the sheet of deformable material **100**, positioned tangentially with respect to the curved surface **116**. In this way, recesses **86** can be formed on the second side of the sheet **100**, and corresponding projections **88** can be formed on the first side **110**.

The rollers **102**, **112** can be formed by axially stacking cylindrical disks, the boundaries of which are illustrated by dashed lines in FIG. **9**. In some embodiments, disks with various shaped projections **114** and/or circumferential spacing between projections **114** can be assembled into a roller that will form fins **66** with different dimensions and geographies. Similarly, the disks can be circumferentially staggered to provide fins **66** with more or less space between rows of contour elements, which can result in wider or narrower spines **76**. The rollers **102**, **112** can be arranged with respect to each other such that the recesses **86** and protrusions **88** on each side of the sheet are formed at specific locations with respect to each other. For example, FIGS. **7-9** illustrate how the rollers **102**, **112** can be aligned to form lateral and longitudinal rows of alternating recesses **86** and protrusions **88** along the sheet **100**. The lateral rows are separated by narrow gaps where the sheet **100** can be folded to form corrugations such that the lateral rows become legs **82** and the gaps become spines **76**. In the illustrated embodiment, the rollers **102**, **112** are staggered slightly to form serpentine-shaped spines **76**. In other embodiments, the rollers **102**, **112** can be aligned to form straight spines **76**. In still other embodiments, the positioning, size, and/or shape of the projections **104**, **114** on the first and/or second rollers **102**, **112** can be varied to change the geometry and/or topography of the fin **66**. In still other embodiments, curved surfaces **106**, **116** of the rollers **102**, **112** can be provided with indentions corresponding (i.e., in location, size, shape, etc.) to the projections **114**, **104** in the opposing roller **112**, **102**, in order to better define the contours formed in the sheet **100**.

FIG. **10** illustrates a method of forming fins **66** according to another embodiment of the invention. The method illustrated in FIG. **10** uses star-shaped rollers to simultaneously form contour elements and partially fold the fin **66**. A first star-shaped disk **120** represents a first star-shaped roller that is positioned on a first side **110** of a sheet of deformable material **100** in the illustrated embodiment of FIG. **10**. Along the circumference of the first disk **120**, alternating ridges **122** and crevasses **124** create the star shape of the disk. The ridges **122** and crevasses **124** can contribute to the formation of peaks **78** and valleys **80** as will be described in further detail below. Between each ridge **122** and crevasse **124** is formed a projection **126** or an indentation **128**. The projections **126** and indentions **128** can form recesses **86** and protrusions **88** in the fin as will also be discussed in further detail below. In some embodiments, such as the illustrated embodiment, the projections **126** and indentions **128** can be geometric complements and have multiple planes of symmetry as discussed

12

previously with respect to recesses **86** and protrusions **88**. In other embodiments, the ridges **122** can be geometric complements of crevasses **124**.

A second star-shaped disk **130** in FIG. **10** represents a second star-shaped roller that can have alternating ridges **132** and crevasses **134** that separate alternating projections **136** and indentions **138** similar (i.e., in shape, size, etc.) to those of the first disk **120**. Alternatively or in addition, the projections **136** can be geometric complements of indentions **128** and projections **126** can be geometric complements of indentions **138**, in which case, projections **126**, **136** need not be geometric complements of indentions **128**, **138** on the same disk. The second star-shaped disk **130** is positioned on a second side **140** of the sheet of material **100**.

The first and second star-shaped disks **120**, **130** can be positioned with respect to each other such that each ridge **122** of the first disk **120** fits within a crevasse **134** of the second disk **130** and each ridge **132** of the second disk **130** fits within a crevasse **124** of the first disk **120** as the disks **120**, **130** turn on their respective axes. Thus, when the sheet of deformable material **100** is fed between the star-shaped disks **120**, **130**, the corresponding ridges **122** and crevasses **134** fold the material to form peaks **78**, and corresponding ridges **132** and crevasses **124** fold the material to form valleys **80**. Similarly, the projections **126**, **136** and corresponding indentions **138**, **128** form recesses **86** and protrusions **88** in the fin **66**.

Star-shaped rollers can be made up of star-shaped disks **120** that are stacked axially, similar to the arrangement discussed above with respect to the embodiment of FIG. **9**. FIG. **11** illustrates how these star-shaped disks **120** can be stacked in an alternating arrangement such that a projection **126** in one disk is positioned adjacent an indentation **128** in a second disk. Adjacent disks can be staggered such that the ridges **122** and crevasses **124** in one disk are not in direct alignment with the ridges **122** and crevasses **124** in a second disk, as shown in FIG. **11**. By complementary positioning of two star-shaped rolls having this arrangement of disks, a fin **66** can be formed having serpentine spines **76**, as shown in FIGS. **3-8**.

After the fins **66** have been roll-formed and folded, they can be cut to the appropriate size and then fined into tubes **26**. In other embodiments, the fins **66** can be cut before they are folded. Alternatively, the tubes **26** can be assembled around the fins **66**. In still other embodiments, the tubes **26** and the fins **66** can be cut to size simultaneously.

The embodiments described above and illustrated in the figures are presented by way of example only and are not intended as a limitation upon the concepts and principles of the present invention. As such, it will be appreciated by one having ordinary skill in the art that various changes in the elements and their configuration and arrangement are possible without departing from the spirit and scope of the present invention.

What is claimed is:

1. A corrugated fin for a heat exchanger, the heat exchanger having a flow path of a first working fluid and a flow path of a second working fluid and being operable to transfer heat between the first and second working fluids, the fin comprising:

a leg defined between adjacent folds and positionable along the flow path of the first working fluid; and
a plurality of convolutions extending inwardly from a distal end of the leg, at least some of the plurality of convolutions having different lengths in the direction of the flow of the first working fluid along the flow path,
wherein the plurality of convolutions include three adjacent convolutions, and wherein two of the three convo-

13

lutions have similar lengths in a direction substantially parallel to a spine formed between the leg and an adjacent leg.

2. The corrugated fin of claim 1, wherein at least one of the plurality of convolutions terminates adjacent to a contour extending along the leg.

3. The corrugated fin of claim 1, wherein at least two non-adjacent ones of the plurality of convolutions extend inwardly a common distance in the direction of the flow of the first working fluid along the flow path.

4. The corrugated fin of claim 1, wherein the corrugated fin includes a plurality of adjacent legs, each of the plurality of adjacent legs including a plurality of convolutions extending inwardly from distal ends of the legs and terminating at different distances from the ends in the direction of the flow of the first working fluid along the flow path.

5. The corrugated fin of claim 1, wherein adjacent ends of at least two of the plurality of convolutions are intersected by a line which is non-perpendicular to the flow of the first working fluid along the first flow path.

6. The corrugated fin of claim 1, wherein the two of the three convolutions are shorter than the other of the three convolutions in the direction substantially parallel to the spine.

7. The corrugated fin of claim 1, wherein the two of the three convolutions are positioned on opposite sides of the other of the three convolutions.

8. The corrugated fin of claim 1, wherein the two of the three convolutions are positioned adjacent each other.

9. A corrugated fin for a heat exchanger, the heat exchanger having a flow path of a first working fluid and a flow path of a second working fluid and being operable to transfer heat between the first and second working fluids, the fin comprising:

a leg defined between adjacent folds and positionable along the flow path of the first working fluid; and a plurality of convolutions extending inwardly from a distal end of the leg and having different lengths in the direction of the flow of the first working fluid along the flow path,

14

wherein the plurality of convolutions include at least three adjacent convolutions with a middle one of the convolutions having a greater length in a direction substantially parallel to a spine formed between the leg and an adjacent leg.

10. A corrugated fin for a heat exchanger, the heat exchanger having a flow path of a first working fluid and a flow path of a second working fluid and being operable to transfer heat between the first and second working fluids, the fin comprising:

a leg defined between adjacent folds and positionable along the flow path of the first working fluid; and a plurality of convolutions extending inwardly from a distal end of the leg and having different lengths in the direction of the flow of the first working fluid along the flow path,

wherein opposite ends of the leg are secured between tube walls and, in a region of connection of the tubes to a collecting tank, the convolutions are configured to compensate for length changes in a stacking direction of the tubes caused by temperature changes.

11. A corrugated fin for a heat exchanger, the heat exchanger having a flow path of a first working fluid and a flow path of a second working fluid and being operable to transfer heat between the first and second working fluids, the fin comprising:

a leg defined between adjacent folds and positionable along the flow path of the first working fluid; and a plurality of convolutions extending inwardly from a distal end of the leg and having different lengths in the direction of the flow of the first working fluid along the flow path,

further comprising a plurality of adjacent legs, each of the plurality of adjacent legs including a plurality of convolutions extending inwardly from distal ends of the legs and terminating at a distance in the direction of the flow of the first working fluid along the flow path different than a corresponding convolution of an adjacent leg.

* * * * *

UNITED STATES PATENT AND TRADEMARK OFFICE
CERTIFICATE OF CORRECTION

PATENT NO. : 8,424,592 B2
APPLICATION NO. : 12/182747
DATED : April 23, 2013
INVENTOR(S) : Steven P. Meshenky and Charles M. Rastall

Page 1 of 1

It is certified that error appears in the above-identified patent and that said Letters Patent is hereby corrected as shown below:

Title Page, Item (63) Related U.S. Application should read:

-- Continuation-in-part of application No. PCT/US2008/051747, filed on January 23, 2008. --.

In the specification,

After the sub-heading "CROSS-REFERENCE TO RELATED APPLICATIONS"

Column 1, lines 8-14 should read -- The present application is a continuation-in-part of application No. PCT/US2008/051747, filed on January 23, 2008. --.

Signed and Sealed this
Nineteenth Day of April, 2016



Michelle K. Lee
Director of the United States Patent and Trademark Office