



US008414655B2

(12) **United States Patent**  
**Alferness et al.**

(10) **Patent No.:** **US 8,414,655 B2**  
(45) **Date of Patent:** **\*Apr. 9, 2013**

(54) **REMOVABLE LUNG REDUCTION DEVICES, SYSTEMS, AND METHODS**

(75) Inventors: **Clifton A. Alferness**, Redmond, WA (US); **Hugo X. Gonzalez**, Woodinville, WA (US); **David H. Dillard**, Redmond, WA (US)

(73) Assignee: **Spiration, Inc.**, Redmond, WA (US)

(\*) Notice: Subject to any disclaimer, the term of this patent is extended or adjusted under 35 U.S.C. 154(b) by 62 days.  
  
This patent is subject to a terminal disclaimer.

(21) Appl. No.: **12/828,629**

(22) Filed: **Jul. 1, 2010**

(65) **Prior Publication Data**

US 2011/0054632 A1 Mar. 3, 2011

**Related U.S. Application Data**

(60) Continuation of application No. 12/428,287, filed on Apr. 22, 2009, now Pat. No. 7,757,692, which is a continuation of application No. 10/847,554, filed on May 17, 2004, now abandoned, which is a division of application No. 09/951,105, filed on Sep. 11, 2001, now abandoned.

(51) **Int. Cl.**  
**A61F 2/04** (2006.01)

(52) **U.S. Cl.** ..... **623/23.65**

(58) **Field of Classification Search** ..... 606/108, 606/198, 191, 106, 200; 128/200.26, 200.24, 128/207.15, 207.14, 207.16; 623/23.65

See application file for complete search history.

(56) **References Cited**

U.S. PATENT DOCUMENTS

2,832,078 A	4/1958	Williams
2,981,254 A	4/1961	Vanderbilt
3,320,972 A	5/1967	High et al.
3,445,916 A	5/1969	Schulte
3,472,230 A	10/1969	Forgarty
3,540,431 A	11/1970	Modin-Uddin
3,617,060 A	11/1971	Iezzi

(Continued)

FOREIGN PATENT DOCUMENTS

CA	2375752	1/2001
CA	2401331	3/2001

(Continued)

OTHER PUBLICATIONS

U.S. Appl. No. 09/686,204, filed Oct. 10, 2000, and its ongoing prosecution history including without limitation Office Actions, Amendments, Remarks, and any other potentially relevant documents.

(Continued)

*Primary Examiner* — Pedro Philogene

(74) *Attorney, Agent, or Firm* — Knobbe, Martens, Olson & Bear, LLP

(57) **ABSTRACT**

An air passageway obstruction device includes a frame structure and a flexible membrane overlying the frame structure. The frame structure is collapsible upon advancement of the device into the air passageway, expandable into a rigid structure upon deploying in the air passageway and recollapsible upon removal from the air passageway. The flexible membrane obstructs inhaled air flow into a lung portion communicating with the air passageway. The device may be removed after deployment in an air passageway by recollapsing the device and pulling the device proximally through a catheter.

**18 Claims, 7 Drawing Sheets**

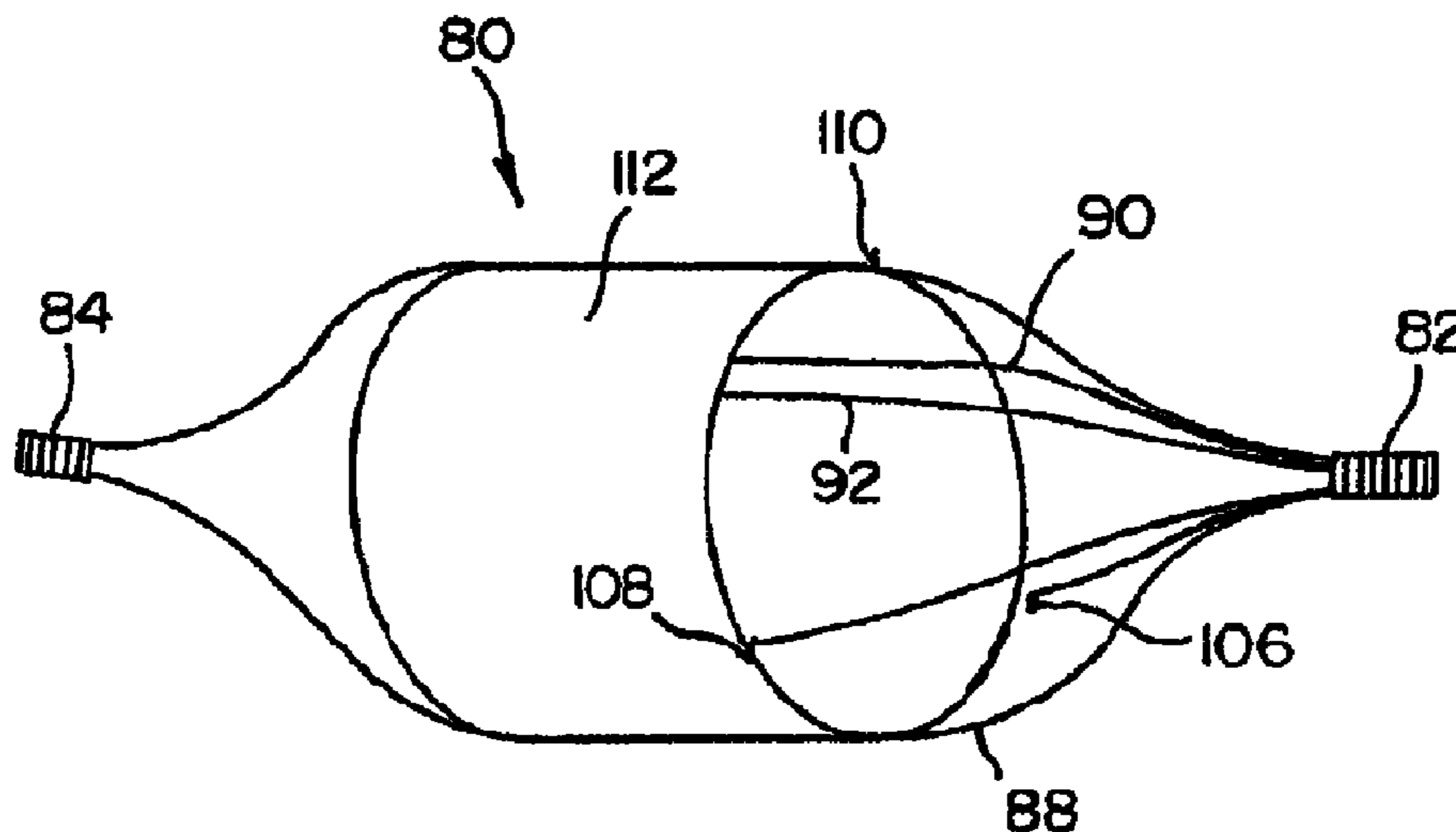

# US 8,414,655 B2

U.S. PATENT DOCUMENTS						
3,657,744	A	4/1972 Ersek	5,683,451	A	11/1997	Lenker et al.
3,671,979	A	6/1972 Mouloupoulos	5,693,089	A	12/1997	Inoue
3,757,783	A	9/1973 Alley	5,697,968	A	12/1997	Rogers et al.
3,760,808	A	9/1973 Bleuer	5,702,343	A	12/1997	Alferness
3,788,327	A	1/1974 Donowitz et al.	5,702,409	A	12/1997	Rayburn et al.
3,874,388	A	4/1975 King et al.	5,725,519	A	3/1998	Penner et al.
4,014,318	A	3/1977 Dockum et al.	5,752,965	A	5/1998	Francis et al.
4,056,854	A	11/1977 Boretos et al.	5,755,770	A	5/1998	Ravenscroft
4,084,268	A	4/1978 Ionescu et al.	5,797,960	A	8/1998	Stevens et al.
4,086,665	A	5/1978 Poirier	5,800,339	A	9/1998	Salama
4,212,463	A	7/1980 Repinski et al.	5,803,078	A	9/1998	Brauner
4,218,782	A	8/1980 Rygg	5,833,694	A	11/1998	Poncet
4,222,126	A	9/1980 Boretos et al.	5,840,081	A	11/1998	Andersen et al.
4,250,873	A	2/1981 Bonnet	5,851,232	A	12/1998	Lois
4,302,854	A	12/1981 Runge	5,855,587	A	1/1999	Hyon
4,339,831	A	7/1982 Johnson	5,855,597	A	1/1999	Jayaraman
4,569,674	A	2/1986 Phillips et al.	5,855,601	A	1/1999	Bessler et al.
4,582,058	A	4/1986 Depel et al.	5,876,445	A	3/1999	Andersen et al.
4,592,741	A	6/1986 Vincent	5,925,063	A	7/1999	Khosravi
4,619,246	A	10/1986 Molgaard-Nielsen et al.	5,944,738	A	8/1999	Amplatz et al.
4,681,110	A	7/1987 Wiktor	5,947,997	A	9/1999	Pavcnik et al.
4,710,192	A	12/1987 Liotta et al.	5,954,636	A	9/1999	Schwartz et al.
4,727,873	A	3/1988 Mobin-Uddin	5,954,766	A	9/1999	Zadno-Azizi et al.
4,732,152	A	3/1988 Wallsten et al.	5,957,949	A	9/1999	Leonhardt et al.
4,759,758	A	7/1988 Gabbay	5,972,009	A	10/1999	Fortier et al.
4,795,449	A	1/1989 Schneider et al.	5,976,158	A	11/1999	Adams et al.
4,808,183	A	2/1989 Panje	5,976,174	A	11/1999	Ruiz
4,819,664	A	4/1989 Nazari	5,984,965	A	11/1999	Knapp et al.
4,830,003	A	5/1989 Wolff et al.	6,003,517	A	12/1999	Sheffield et al.
4,832,680	A	5/1989 Haber et al.	6,007,575	A	12/1999	Samuels
4,846,836	A	7/1989 Reich	6,009,614	A	1/2000	Morales
4,850,999	A	7/1989 Planck	6,010,525	A	1/2000	Bonutti et al.
4,852,568	A	8/1989 Kensey	6,020,380	A	2/2000	Killian
4,877,025	A	10/1989 Hanson	6,027,525	A	2/2000	Suh et al.
4,934,999	A	6/1990 Bader	6,045,560	A	4/2000	McKean et al.
4,968,294	A	11/1990 Salama	6,051,022	A	4/2000	Cai et al.
4,979,505	A	12/1990 Cox	6,068,635	A	5/2000	Gianotti
5,061,274	A	10/1991 Kensey	6,068,638	A	5/2000	Makower
5,116,360	A	5/1992 Pinchuk et al.	6,077,291	A	6/2000	Das
5,116,564	A	5/1992 Jansen et al.	6,083,255	A	7/2000	Laufer et al.
5,123,919	A	6/1992 Sauter et al.	6,096,027	A	8/2000	Layne
5,151,105	A	9/1992 Kwan-Gett	6,099,551	A	8/2000	Gabbay
5,158,548	A	10/1992 Lau et al.	6,123,663	A	9/2000	Rebuffat
5,161,524	A	11/1992 Evans	6,132,458	A	10/2000	Stahle et al.
5,283,063	A	2/1994 Freeman	6,135,729	A	10/2000	Aber
5,304,199	A	4/1994 Myers	6,135,991	A	10/2000	Muni et al.
5,306,234	A	4/1994 Johnson	6,141,855	A	11/2000	Morales
5,314,473	A	5/1994 Godin	6,149,664	A	11/2000	Kurz
5,352,240	A	10/1994 Ross	6,162,245	A	12/2000	Jayaraman
5,358,518	A	10/1994 Camilli	6,165,179	A	12/2000	Cathcart et al.
5,366,478	A	11/1994 Brinkerhoff et al.	6,168,614	B1	1/2001	Andersen et al.
5,382,261	A	1/1995 Palmaz	6,174,323	B1	1/2001	Biggs et al.
5,392,775	A	2/1995 Adkins, Jr. et al.	6,183,520	B1	2/2001	Pintauro et al.
5,398,844	A	3/1995 Zaslavsky	6,200,333	B1	3/2001	Laufer
5,409,019	A	4/1995 Wilk	6,203,551	B1	3/2001	Wu
5,411,507	A	5/1995 Hecke	6,206,918	B1	3/2001	Campbell et al.
5,411,552	A	5/1995 Andersen et al.	6,231,589	B1	5/2001	Wessman et al.
5,413,599	A	5/1995 Imachi et al.	6,234,996	B1	5/2001	Bagaoisan et al.
5,417,226	A	5/1995 Juma	6,238,334	B1	5/2001	Easterbrook, III et al.
5,445,626	A	8/1995 Gigante	6,240,615	B1	6/2001	Kimes et al.
5,453,090	A	9/1995 Martinez et al.	6,241,654	B1	6/2001	Alferness
5,484,444	A	1/1996 Braunschweiler et al.	6,245,102	B1	6/2001	Jayaraman
5,486,154	A	1/1996 Kelleher	6,258,100	B1	7/2001	Alferness et al.
5,499,995	A	3/1996 Teirstein	6,267,775	B1	7/2001	Clerc et al.
5,500,014	A	3/1996 Quijano et al.	6,270,527	B1	8/2001	Campbell et al.
5,507,754	A	4/1996 Green et al.	6,287,290	B1	9/2001	Perkins et al.
5,507,797	A	4/1996 Suzuki	6,287,334	B1	9/2001	Moll et al.
5,509,900	A	4/1996 Kirkman	6,293,951	B1	9/2001	Alferness et al.
5,549,626	A	8/1996 Miller et al.	6,302,893	B1	10/2001	Limon et al.
5,549,628	A	8/1996 Cooper et al.	6,312,407	B1	11/2001	Zadno-Azizi et al.
5,562,608	A	10/1996 Sekins et al.	6,325,777	B1	12/2001	Zadno-Azizi et al.
5,562,728	A	10/1996 Lazarus et al.	6,325,778	B1	12/2001	Zadno-Azizi et al.
5,603,698	A	2/1997 Roberts et al.	6,327,772	B1	12/2001	Zadno-Azizi et al.
5,645,565	A	7/1997 Rudd et al.	6,328,689	B1	12/2001	Gonzalez et al.
5,649,953	A *	7/1997 Lefebvre ..... 606/200	6,331,183	B1 *	12/2001	Suon ..... 606/200
5,660,175	A	8/1997 Dayal	6,342,062	B1 *	1/2002	Suon et al. .... 606/200
5,662,713	A	9/1997 Andersen et al.	6,355,014	B1	3/2002	Zadno-Azizi et al.
5,669,933	A	9/1997 Simon et al.	6,398,775	B1	6/2002	Perkins et al.
			6,402,754	B1	6/2002	Gonzalez

# US 8,414,655 B2

6,416,554	B1	7/2002	Alferness et al.	2004/0210248	A1	10/2004	Gordon et al.
6,425,916	B1	7/2002	Garrison et al.	2004/0211412	A1	10/2004	Alferness et al.
6,428,561	B1	8/2002	Johansson-Ruden et al.	2004/0243140	A1	12/2004	Alferness et al.
6,439,233	B1	8/2002	Geertsema	2005/0033310	A1	2/2005	Alferness et al.
6,440,164	B1	8/2002	DiMatteo et al.	2005/0137611	A1	6/2005	Escudero et al.
6,447,530	B1	9/2002	Ostrovsky et al.				
6,458,076	B1	10/2002	Pruitt				
6,458,153	B1	10/2002	Bailey et al.				
6,471,718	B1	10/2002	Staehle et al.				
6,485,407	B2	11/2002	Alferness et al.				
6,488,673	B1	12/2002	Laufer				
6,491,706	B1	12/2002	Alferness et al.				
6,493,589	B1	12/2002	Medhkour et al.				
6,503,272	B2	1/2003	Duerig et al.				
6,510,846	B1	1/2003	O'Rourke				
6,514,290	B1	2/2003	Loomas				
6,527,761	B1	3/2003	Soltesz et al.				
6,540,782	B1	4/2003	Snyders				
6,544,291	B2	4/2003	Taylor				
6,558,429	B2	5/2003	Taylor				
6,568,387	B2	5/2003	Davenport et al.				
6,569,166	B2	5/2003	Gonzalez				
6,585,639	B1	7/2003	Kotmel et al.				
6,589,256	B2	7/2003	Forber				
6,592,594	B2	7/2003	Rimbaugh et al.				
6,599,311	B1	7/2003	Biggs et al.				
6,600,307	B2	7/2003	Turski et al.				
6,610,043	B1	8/2003	Ingenito				
6,629,951	B2	10/2003	Laufer et al.				
6,634,363	B1	10/2003	Danek et al.				
6,638,285	B2	10/2003	Gabbay				
6,669,724	B2	12/2003	Park et al.				
6,679,264	B1	1/2004	Deem et al.				
6,682,250	B2	1/2004	Banks				
6,682,520	B2	1/2004	Ingenito				
6,694,979	B2 *	2/2004	Hundertmark et al. .. 128/207.14				
6,709,401	B2	3/2004	Perkins et al.				
6,712,812	B2	3/2004	Roschak et al.				
6,722,360	B2	4/2004	Doshi				
6,743,259	B2	6/2004	Ginn				
6,749,606	B2	6/2004	Keast et al.				
6,860,847	B2	3/2005	Alferness et al.				
6,887,256	B2	5/2005	Gilson et al.				
6,904,909	B2	6/2005	Andreas et al.				
6,929,637	B2	8/2005	Gonzalez et al.				
6,941,950	B2	9/2005	Wilson et al.				
6,951,571	B1	10/2005	Srivastava				
6,958,076	B2	10/2005	Acosta et al.				
6,989,027	B2	1/2006	Allen et al.				
7,011,094	B2	3/2006	Rapacki et al.				
7,141,046	B2	11/2006	Perkins et al.				
7,175,644	B2	2/2007	Cooper et al.				
7,278,430	B2	10/2007	Kumar				
7,357,795	B2	4/2008	Kaji et al.				
7,412,977	B2	8/2008	Fields et al.				
7,434,578	B2 *	10/2008	Dillard et al. .... 128/200.24				
7,842,061	B2 *	11/2010	Dillard et al. .... 606/191				
7,875,048	B2	1/2011	Dillard et al.				
2001/0010017	A1	7/2001	Letac et al.				
2002/0077593	A1	6/2002	Perkins et al.				
2002/0077696	A1	6/2002	Zadno-Azizi et al.				
2002/0095209	A1	7/2002	Zadno-Azizi et al.				
2002/0112729	A1	8/2002	DeVore et al.				
2002/0147462	A1	10/2002	Mair et al.				
2003/0018327	A1	1/2003	Truckai et al.				
2003/0050648	A1	3/2003	Alferness et al.				
2003/0051733	A1	3/2003	Kotmel et al.				
2003/0055331	A1	3/2003	Kotmel et al.				
2003/0127090	A1	7/2003	Gifford et al.				
2003/0154988	A1	8/2003	DeVore et al.				
2003/0180922	A1	9/2003	Eaton et al.				
2003/0181922	A1	9/2003	Alferness				
2003/0183235	A1	10/2003	Rimbaugh et al.				
2003/0195385	A1	10/2003	De Vore				
2003/0212412	A1	11/2003	Dillard et al.				
2003/0216769	A1	11/2003	Dillard et al.				
2004/0039250	A1	2/2004	Tholfson et al.				
2004/0143283	A1	7/2004	McGill et al.				
2004/0206349	A1	10/2004	Alferness et al.				

## FOREIGN PATENT DOCUMENTS

CA	2408923	11/2001
DE	100 04 979	8/2000
EP	1 151 729	11/2001
EP	1 157 663	11/2001
EP	1 206 276	5/2002
GB	2 324 729	11/1998
GB	2 348 138	9/2000
JP	2004-535887	12/2004
JP	2005-527297	9/2005
RU	2140211	10/1999
SU	852321	8/1981
SU	1371700	2/1988
SU	1593651	9/1990
WO	WO 88/09683	12/1988
WO	WO 94/26175	11/1994
WO	WO 95/32018	11/1995
WO	WO 96/34582	11/1996
WO	WO 97/13471	4/1997
WO	WO 97/27893	8/1997
WO	WO 97/44085	11/1997
WO	WO 98/01084	1/1998
WO	WO 98/19633	5/1998
WO	WO 98/39047	9/1998
WO	WO 98/44854	10/1998
WO	WO 98/48706	11/1998
WO	WO 99/01076	1/1999
WO	WO 99/13801	3/1999
WO	WO 99/26692	6/1999
WO	WO 99/32040	7/1999
WO	WO 99/42059	8/1999
WO	WO 99/42161	8/1999
WO	WO 99/59503	11/1999
WO	WO 99/64109	12/1999
WO	WO 00/18329	4/2000
WO	WO 00/27292	5/2000
WO	WO 00/42950	7/2000
WO	WO 00/51500	9/2000
WO	WO 00/51510	9/2000
WO	WO 00/62699	10/2000
WO	WO 00/78386	12/2000
WO	WO 00/78407	12/2000
WO	WO 01/02042	1/2001
WO	WO 01/03641	1/2001
WO	WO 01/03642	1/2001
WO	WO 01/05334	1/2001
WO	WO 01/10313	2/2001
WO	WO 01/10314	2/2001
WO	WO 01/12104	2/2001
WO	WO 01/13839	3/2001
WO	WO 01/13908	3/2001
WO	WO 01/28433	4/2001
WO	WO 01/30266	5/2001
WO	WO 01/45590	6/2001
WO	WO 01/49213	7/2001
WO	WO 01/52775	7/2001
WO	WO 01/54585	8/2001
WO	WO 01/54625	8/2001
WO	WO 01/54685	8/2001
WO	WO 01/66190	9/2001
WO	WO 01/74271	10/2001
WO	WO 01/87170	11/2001
WO	WO 01/89366	11/2001
WO	WO 01/95786	12/2001
WO	WO 02/05884	1/2002
WO	WO 02/22072	3/2002
WO	WO 02/32333	4/2002
WO	WO 02/34322	5/2002
WO	WO 02/38038	5/2002
WO	WO 02/47575	6/2002
WO	WO 02/056794	7/2002
WO	WO 02/064045	8/2002
WO	WO 02/064190	8/2002

WO	WO 02/069823	9/2002
WO	WO 02/094087	11/2002
WO	WO 03/022124	3/2003
WO	WO 03/030975	4/2003
WO	WO 03/034927	5/2003
WO	WO 03/034946	5/2003
WO	WO 03/041779	5/2003
WO	WO 03/047468	6/2003
WO	WO 03/078579	9/2003
WO	WO 03/079944	10/2003
WO	WO 03/088820	10/2003
WO	WO 03/099164	12/2003
WO	WO 2004/010845	5/2004
WO	WO 2005/013835	2/2005
WO	WO 2009/135070	11/2009

## OTHER PUBLICATIONS

U.S. Appl. No. 09/379,972, filed Aug. 24, 1999, Pub. No. 2010/0256714, published Oct. 7, 2010 and its ongoing prosecution history including without limitation Office Actions, Amendments, Remarks, and any other potentially relevant documents.

U.S. Appl. No. 09/379,973, filed Aug. 24, 1999 and its ongoing prosecution history including without limitation Office Actions, Amendments, Remarks, and any other potentially relevant documents.

U.S. Appl. No. 09/780,232, filed Feb. 9, 2001, Pub. No. 2001/0025132, published Sep. 27, 2001 and its ongoing prosecution history including without limitation Office Actions, Amendments, Remarks, and any other potentially relevant documents.

U.S. Appl. No. 09/902,821, filed Jul. 10, 2001 and its ongoing prosecution history including without limitation Office Actions, Amendments, Remarks, and any other potentially relevant documents.

U.S. Appl. No. 09/912,613, filed Jul. 24, 2001, Pub. No. 2001/0041906, published Nov. 15, 2001 and its ongoing prosecution history including without limitation Office Actions, Amendments, Remarks, and any other potentially relevant documents.

U.S. Appl. No. 10/052,875, filed Oct. 25, 2001, Pub. No. 2003/0083671, published May 1, 2003, and its ongoing prosecution history including without limitation Office Actions, Amendments, Remarks, and any other potentially relevant documents.

U.S. Appl. No. 09/881,862, filed Jun. 14, 2001, Pub. No. 2001/0052344, published Dec. 20, 2001 and its ongoing prosecution history including without limitation Office Actions, Amendments, Remarks, and any other potentially relevant documents.

U.S. Appl. No. 09/901,764, filed Jul. 10, 2001, Pub. No. 2003/0013935, published Jan. 16, 2003 and its ongoing prosecution history including without limitation Office Actions, Amendments, Remarks, and any other potentially relevant documents.

U.S. Appl. No. 10/317,667, filed Dec. 11, 2002, Pub. No. 2003/0158515, published Aug. 21, 2003, and its ongoing prosecution history including without limitation Office Actions, Amendments, Remarks, and any other potentially relevant documents.

U.S. Appl. No. 10/744,577, filed Dec. 22, 2003, Pub. No. 2004/0167636, published Aug. 26, 2004, and its ongoing prosecution history including without limitation Office Actions, Amendments, Remarks, and any other potentially relevant documents.

U.S. Appl. No. 10/746,981, filed Dec. 23, 2003, Pub. No. 2004/0143282, published Jul. 22, 2004 and its ongoing prosecution history including without limitation Office Actions, Amendments, Remarks, and any other potentially relevant documents.

U.S. Appl. No. 10/933,778, filed Sep. 3, 2004, Pub. No. 2005/0033344, published Feb. 10, 2005 and its ongoing prosecution history including without limitation Office Actions, Amendments, Remarks, and any other potentially relevant documents.

U.S. Appl. No. 10/081,712, filed Feb. 21, 2002, and its ongoing prosecution history including without limitation Office Actions, Amendments, Remarks, and any other potentially relevant documents.

U.S. Appl. No. 09/951,105, filed Sep. 11, 2001, and its ongoing prosecution history including without limitation Office Actions, Amendments, Remarks, and any other potentially relevant documents.

U.S. Appl. No. 10/178,073, filed Jun. 21, 2002, and its ongoing prosecution history including without limitation Office Actions, Amendments, Remarks, and any other potentially relevant documents.

U.S. Appl. No. 10/103,487, filed Mar. 20, 2002, and its ongoing prosecution history including without limitation Office Actions, Amendments, Remarks, and any other potentially relevant documents.

U.S. Appl. No. 10/418,929, filed Apr. 17, 2003, and its ongoing prosecution history including without limitation Office Actions, Amendments, Remarks, and any other potentially relevant documents.

U.S. Appl. No. 10/124,790, filed Apr. 16, 2002, and its ongoing prosecution history including without limitation Office Actions, Amendments, Remarks, and any other potentially relevant documents.

U.S. Appl. No. 10/143,353, filed May 9, 2002, and its ongoing prosecution history including without limitation Office Actions, Amendments, Remarks, and any other potentially relevant documents.

U.S. Appl. No. 10/150,547, filed May 17, 2002, and its ongoing prosecution history including without limitation Office Actions, Amendments, Remarks, and any other potentially relevant documents.

U.S. Appl. No. 10/847,554, filed May 17, 2004, and its ongoing prosecution history including without limitation Office Actions, Amendments, Remarks, and any other potentially relevant documents.

U.S. Appl. No. 10/387,963, filed Mar. 12, 2003, and its ongoing prosecution history including without limitation Office Actions, Amendments, Remarks, and any other potentially relevant documents.

U.S. Appl. No. 10/847,427, filed May 17, 2004, and its ongoing prosecution history including without limitation Office Actions, Amendments, Remarks, and any other potentially relevant documents.

U.S. Appl. No. 10/848,041, filed May 18, 2004, and its ongoing prosecution history including without limitation Office Actions, Amendments, Remarks, and any other potentially relevant documents.

U.S. Appl. No. 10/848,571, filed May 17, 2004, and its ongoing prosecution history including without limitation Office Actions, Amendments, Remarks, and any other potentially relevant documents.

Amendment mailed Mar. 3, 2004 in response to Office Action dated Oct. 3, 2003 in the related copending U.S. Appl. No. 09/951,105.

Andre A. Kulisz, Autocath 100—Nonsurgical, Intraurethral Bladder Control Device for Urinary Incontinent and Urinary Retentive Women—Another Dr. Kulisz's Development, <http://www.kulisz.com/autocath.htm>, 2003, 3 pp.

Dillard et al., "Evaluation of a Novel Intra-bronchial Valve Device to Produce Lung Volume Reduction," Poster show at conference in Jun. 2002.

EWS Endobronchial Watanabe Spigots, Novatech, edited Apr. 17, 2002.

Harris et al., "The Experimental Production in Dogs of Emphysema with Associated Asthmatic Syndrome by Means of an Intratracheal Ball Valve," *J Exp Med* 30:1919; 75-88.

Horiuchi et al: Three Cases of Intractable Pneumothorax Treated Successfully by Bronchial Embolization using Silicon; *JJSB*, 2001. pp. 25-30.

Inaspettato: Endoscopic Treatment of Bronchopleural Fistulas Using N-butyl-2-cyanoacrylate; *Surgical Laparoscopy & Endoscopy*; vol. 4 No. 1, pp. 62-64, 1994.

Jones et al: Closure of a Benign Broncho-Oesophageal Fistula by Endoscopic Injection of Bovine Collagen, Cyanocrylate Glue and Gelfoam; 1996, pp. 53-55 *Aust. N.Z. J. Surg.*

Lewis et al, "Pulmonary Interstitial Emphysema: Selective Bronchial Occlusion with a Swan-Ganz Catheter." *Archives of Disease in Childhood*, 63:1988, 313-315.

Matthew et al. "Selective Bronchial Obstruction for Treatment of Bullous Interstitial Emphysema," *J. of Ped.* 96:1980, 475-477.

Okada et al: Emergent Bronchofiberoptic Bronchial Occlusion for Intractable Pneumothorax with Severe Emphysema; The Japanese Journal of Thoracic and Cardiovascular Surgery, 1998. pp. 1078-1081.

Puhakka et al., "Acute Bronchial Obstruction: An Experimental Rabbit Model Study." Int. J. of Pediatric Otorhinolaryngology. 18:1989, 107-118.

Snider et al., "The Definition of Emphysema: Report of the National Heart Lung and Blood Institute, Division of Lung Diseases Workshop", Am. Ev. Respir. Dis., 132:182-185, 1985.

Watanabe et al: Bronchial Embolization Using Dental Impression Material in a Case of Pyelo-bronchial Fistula with Candida Fungemia; 1991. Journal of the Japan Society for Bronchology, pp. 607-610.

European Supplemental Search Report in European Application. No. 00969008.2, dated Feb. 26, 2004, 5 pp.

International Search Report in International application No. PCT/US00/40701, mailed Jan. 25, 2001, 3 pp.

International Search Report in International application No. PCT/US02/25555, mailed Mar. 19, 2003, 4 pp.

Office Action dated Apr. 28, 2009 for Canadian Application No. 2,459,702.

European Search Report for European application No. 02759335.9 dated Jan. 31, 2007.

Extended European Search Report for European Application No. 08022468.6, dated Jul. 28, 2009.

Office Action dated Apr. 17, 2012 for European Application No. 08022468.6.

US Office Action mailed Oct. 3, 2003 from related copending U.S. Appl. No. 09/951,105.

\* cited by examiner

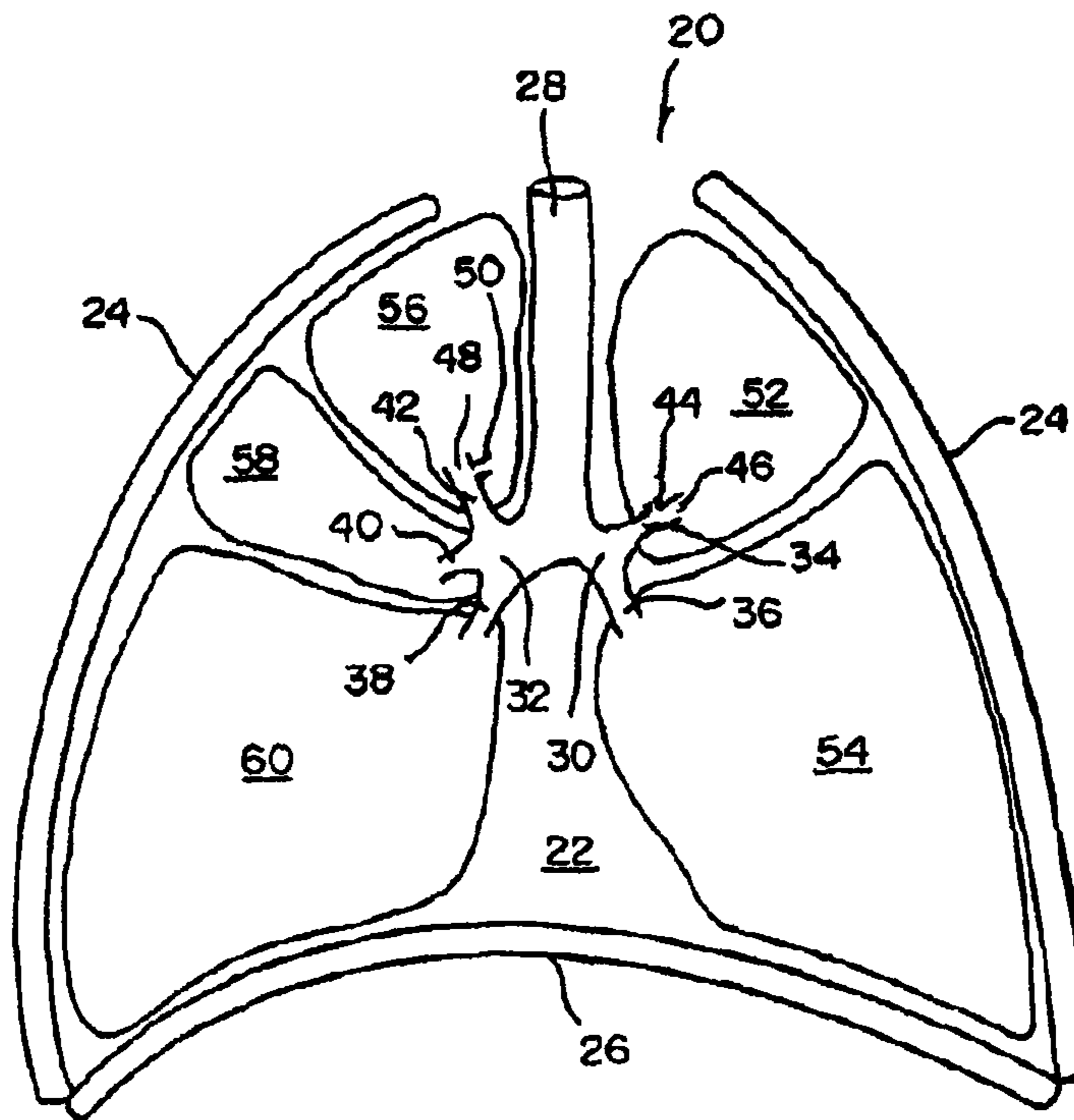

FIG. 1

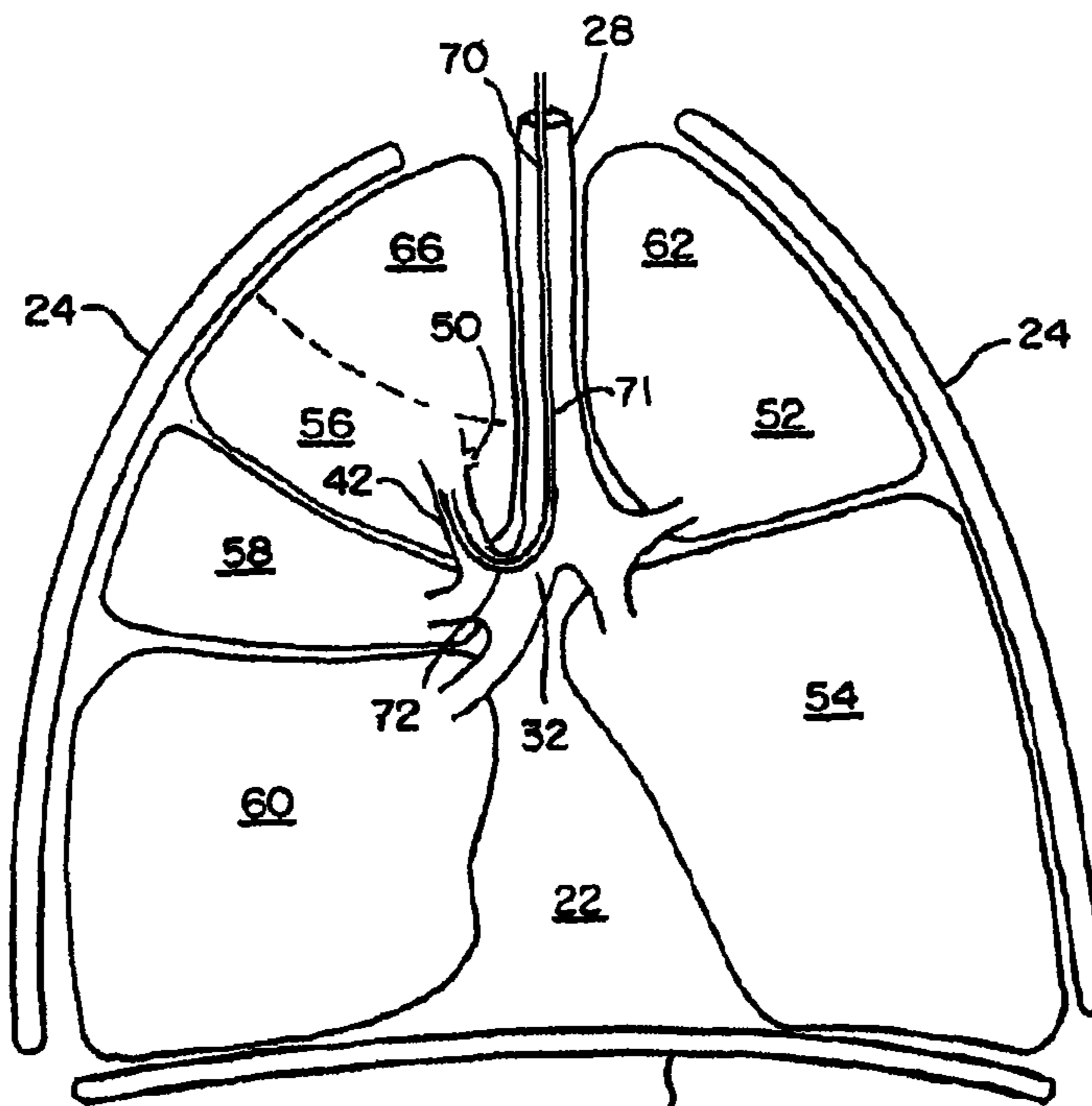

FIG. 2

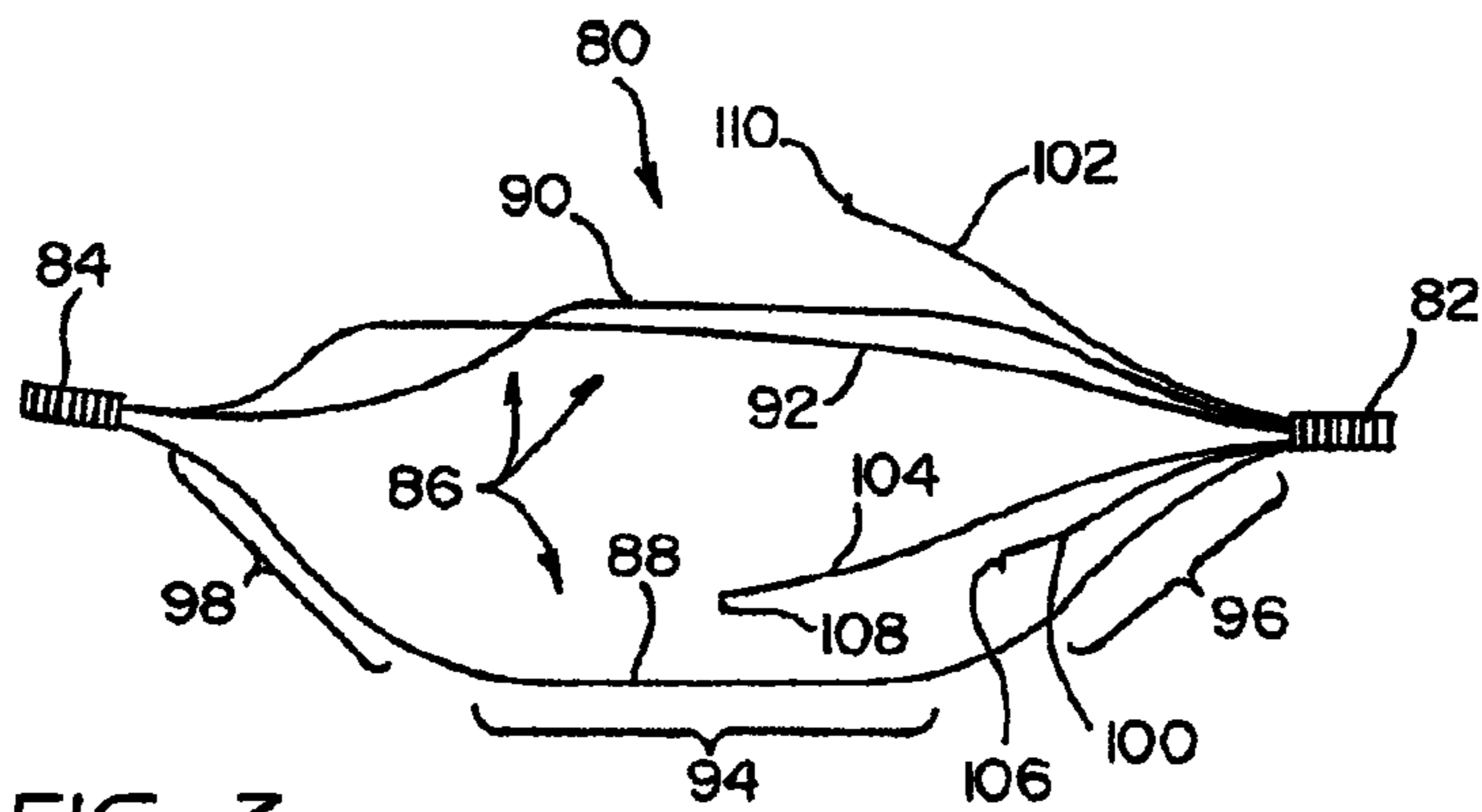

FIG. 3

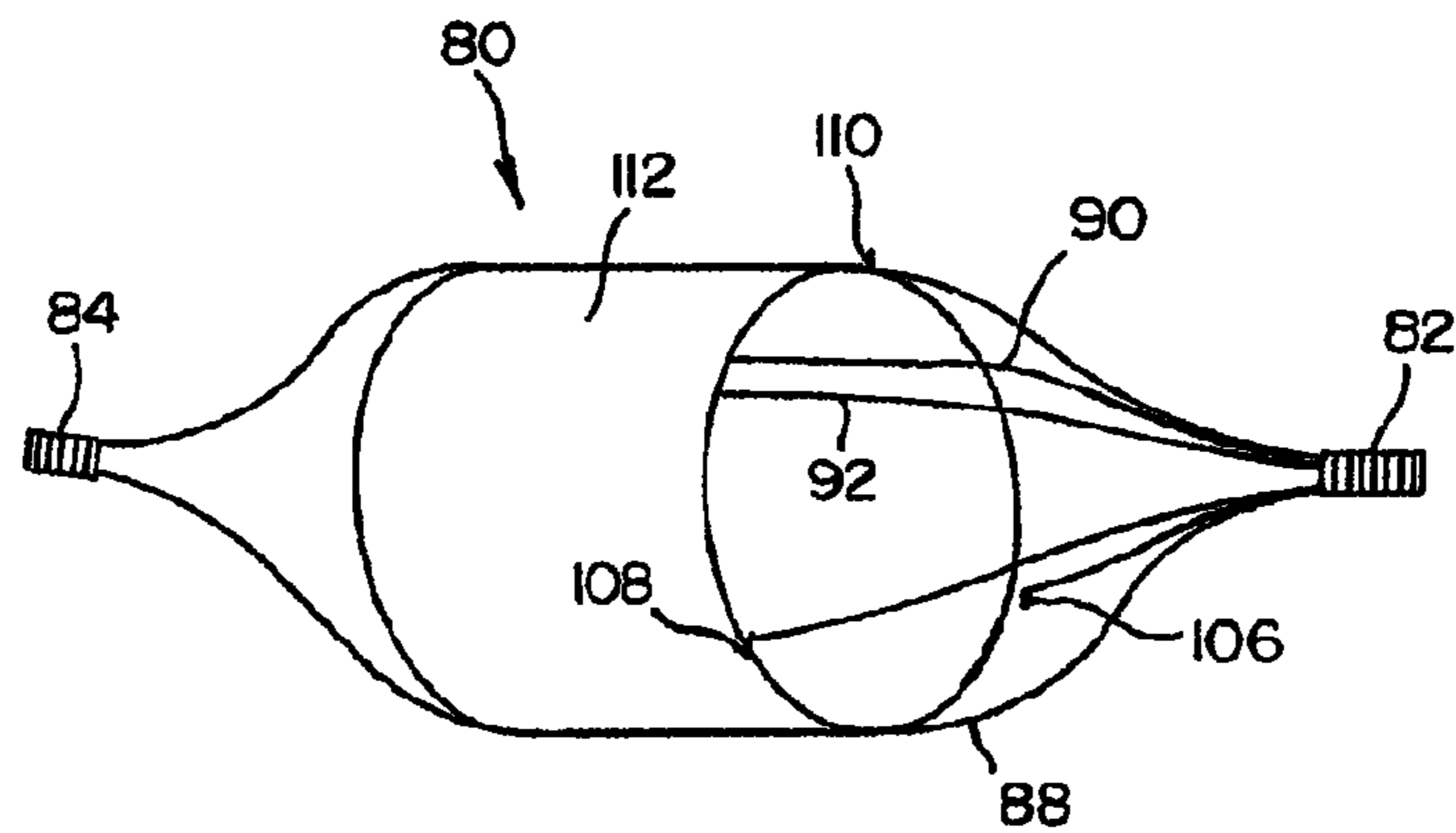

FIG. 4

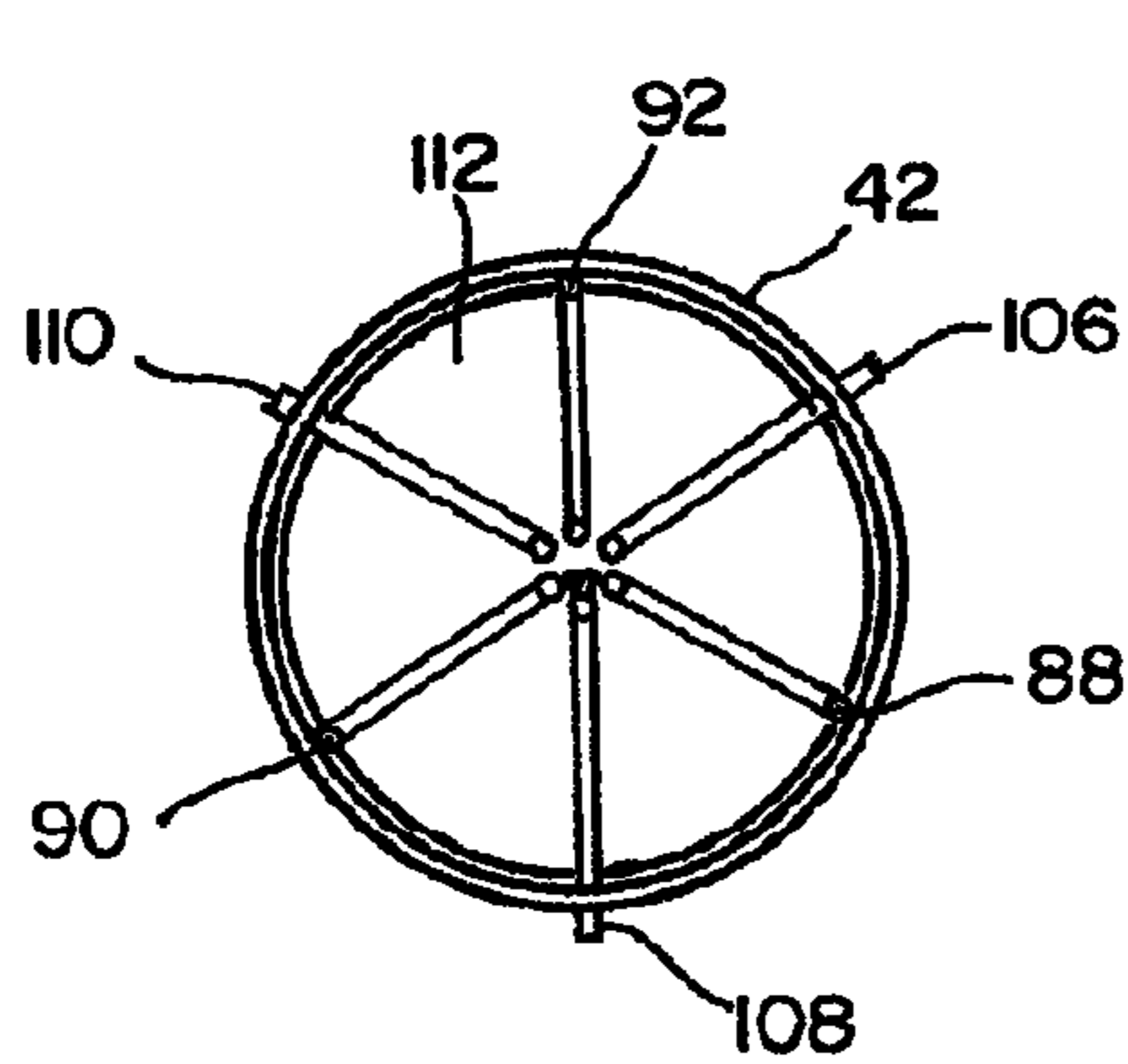

FIG. 5

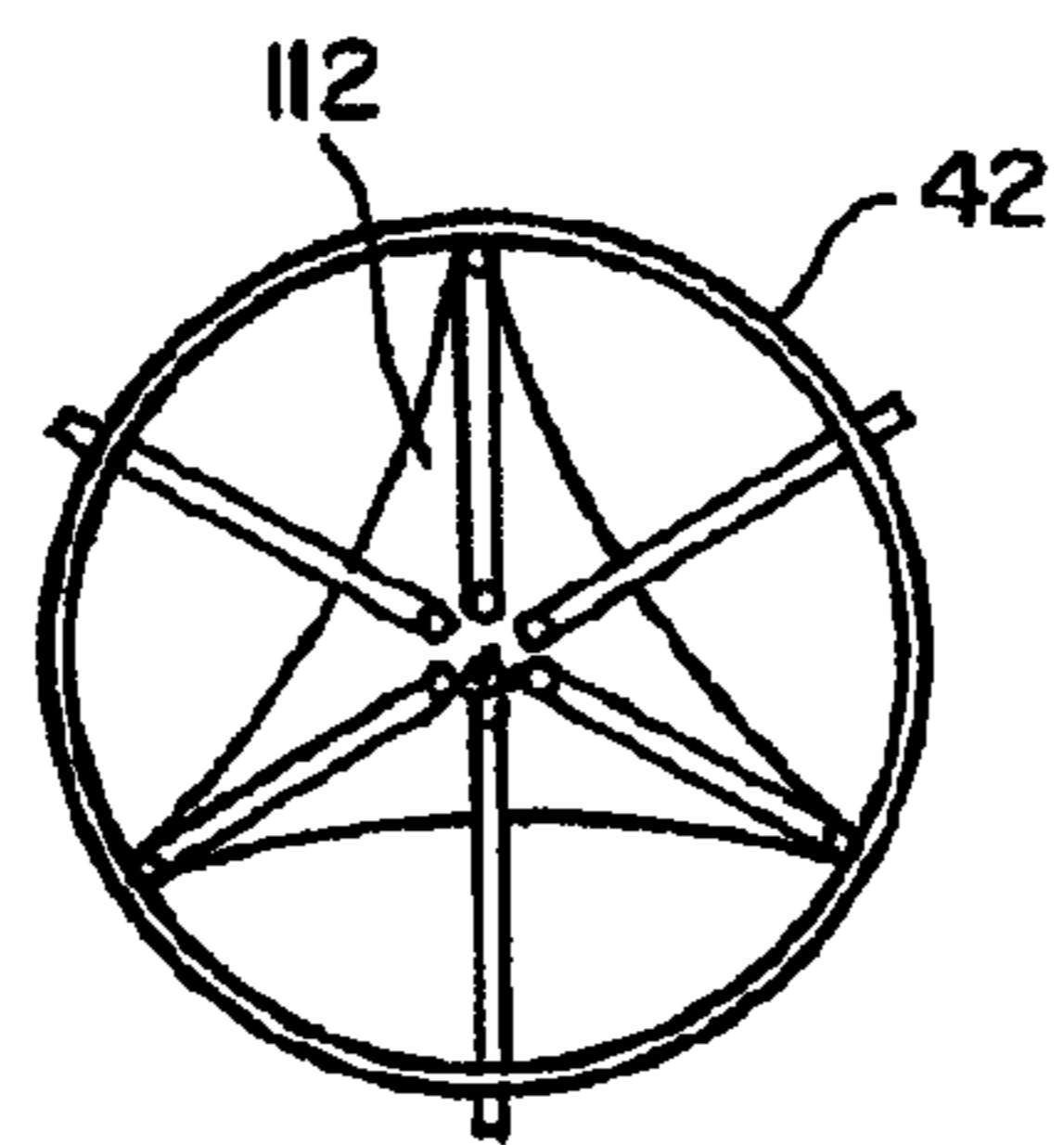

FIG. 6

FIG. 7

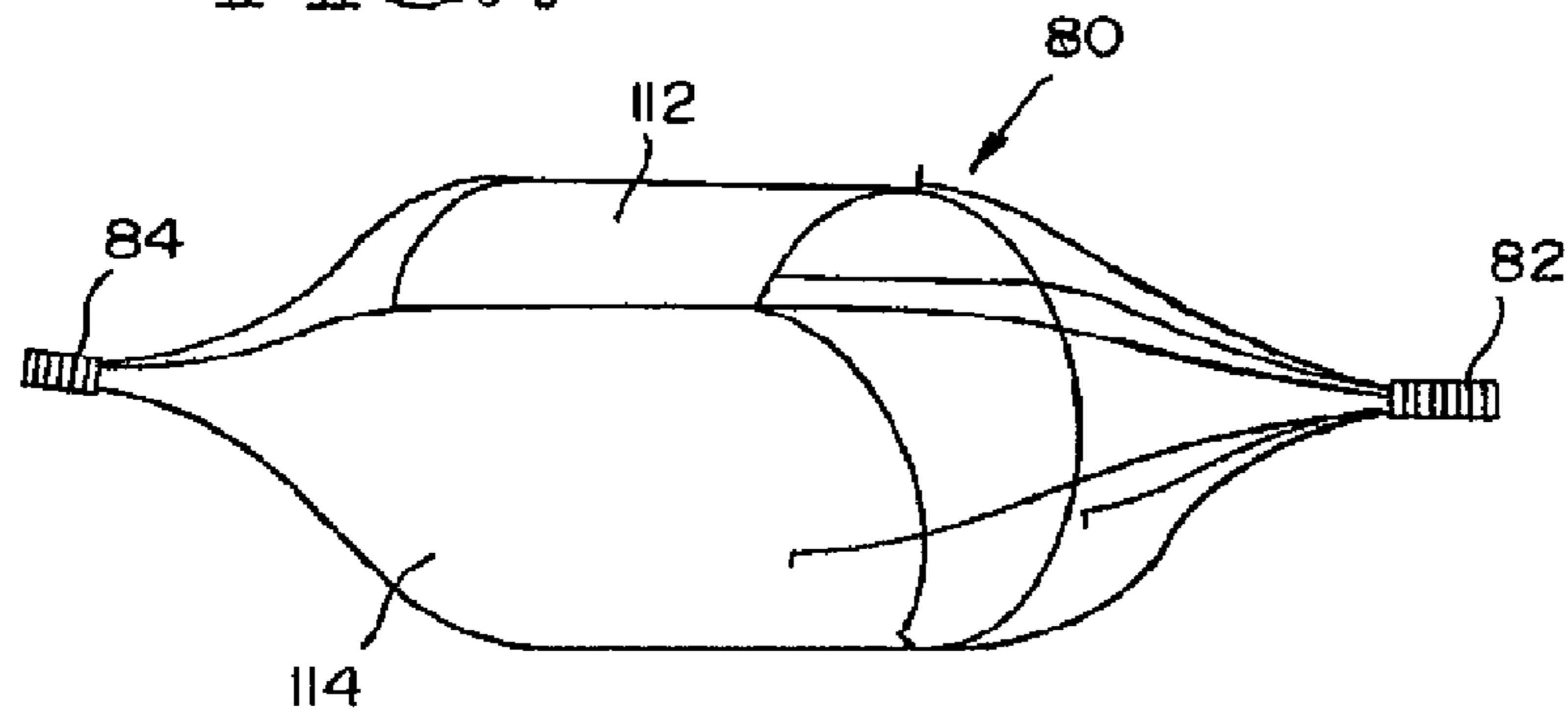

FIG. 8

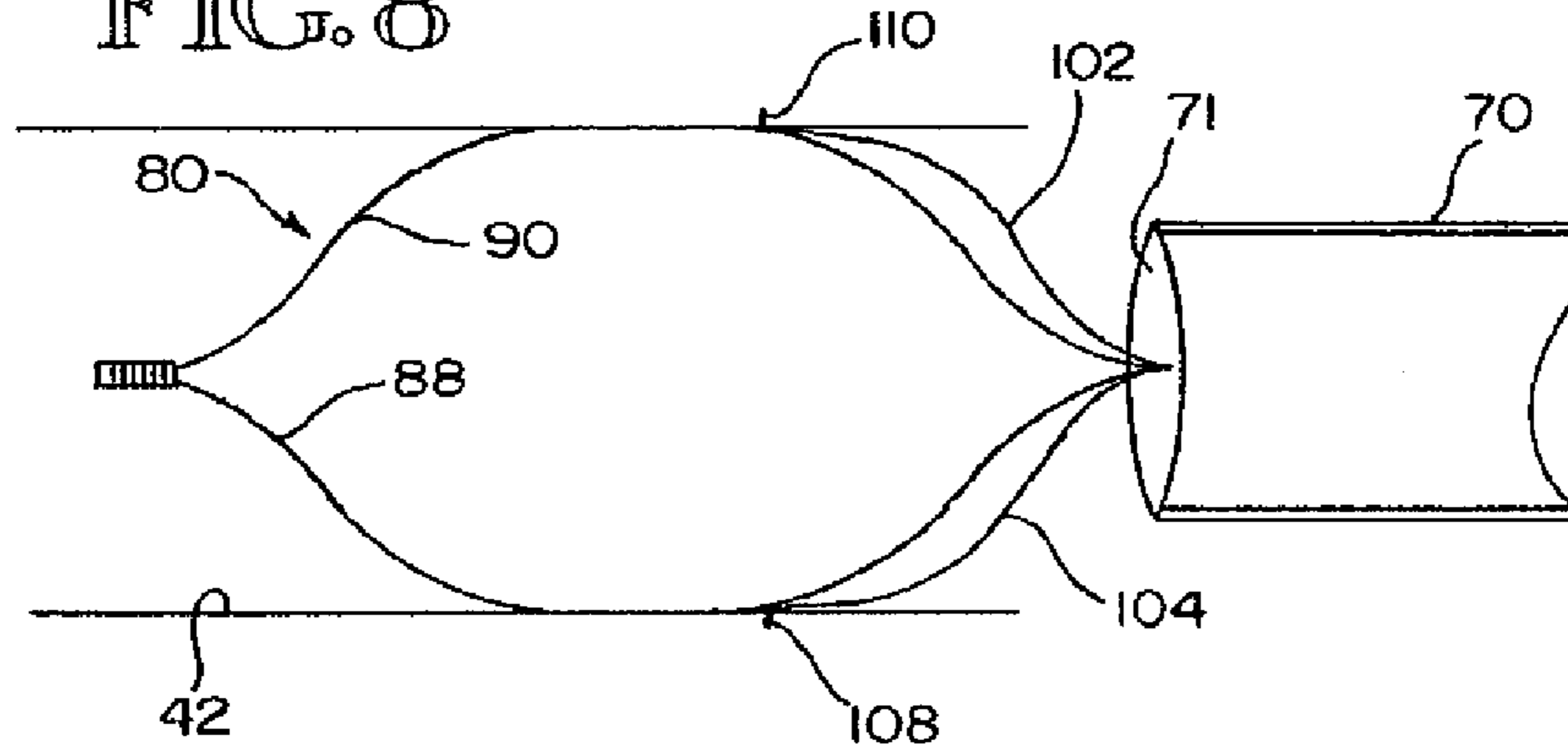
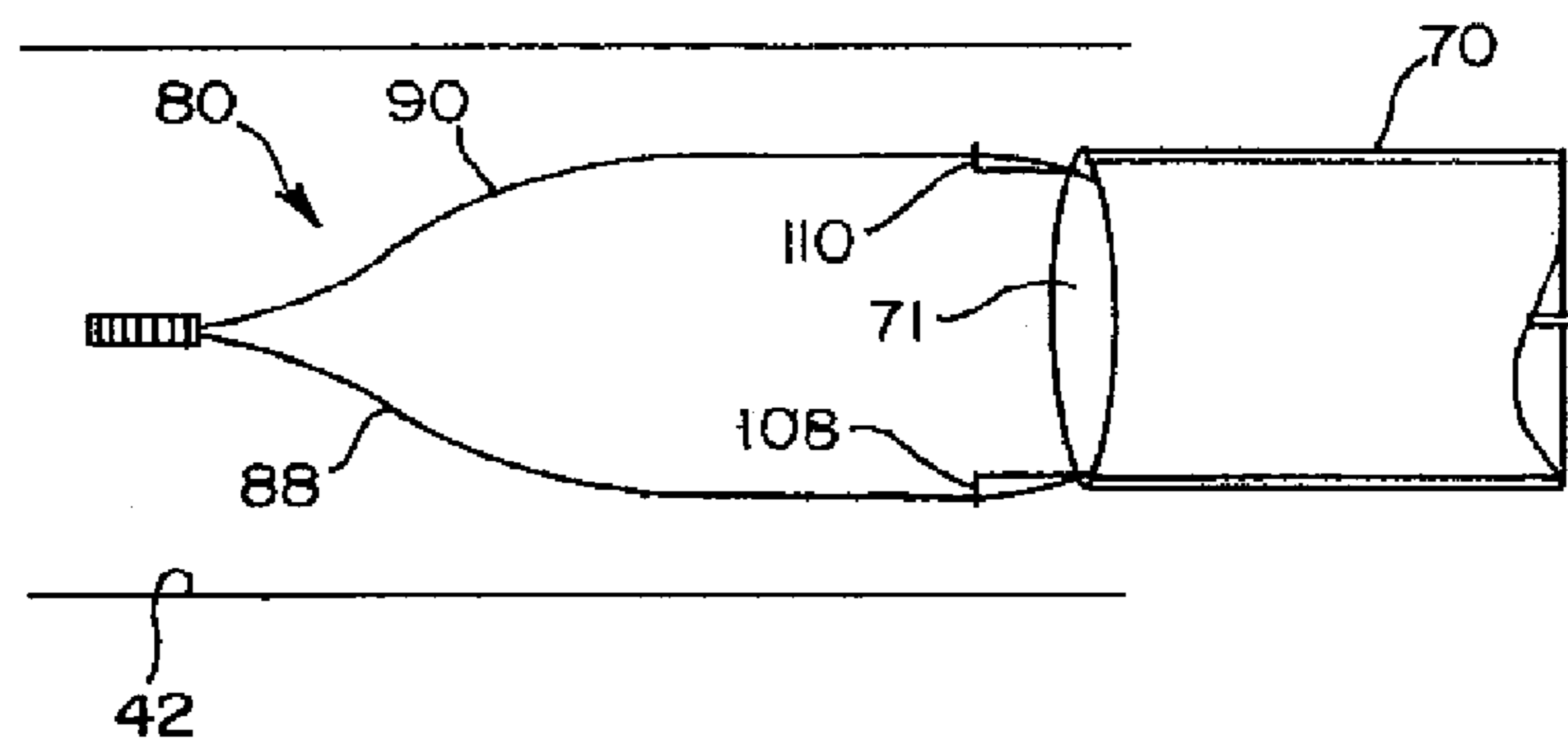
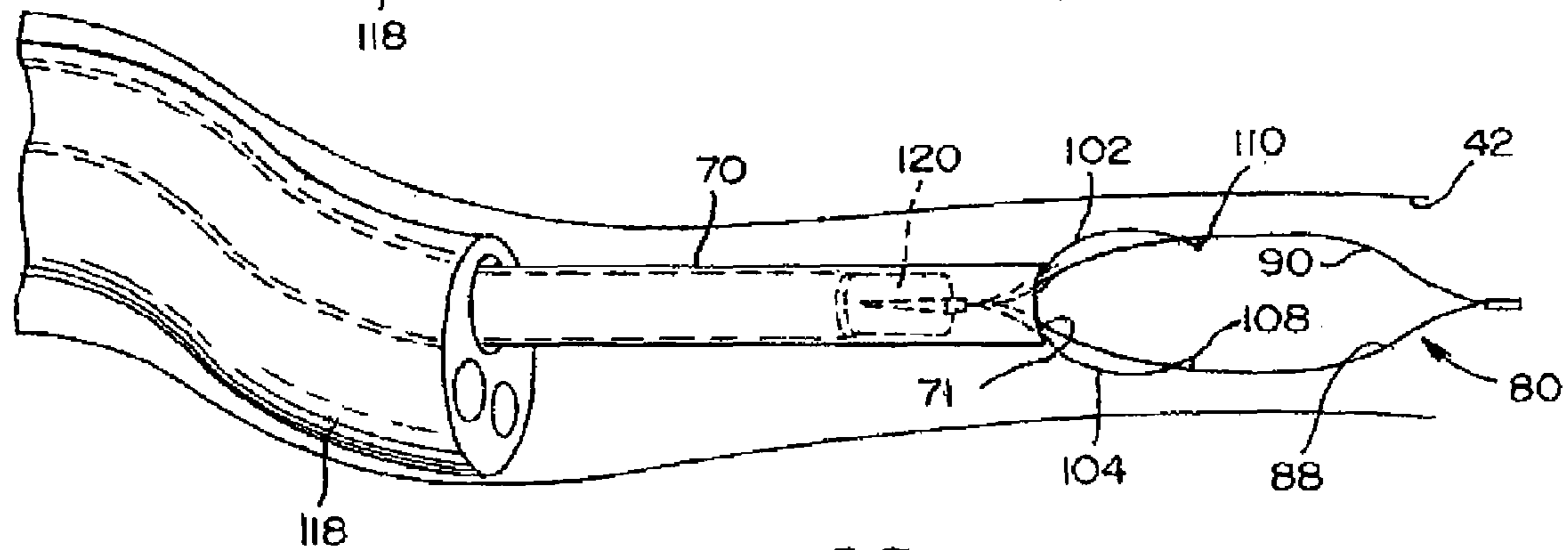
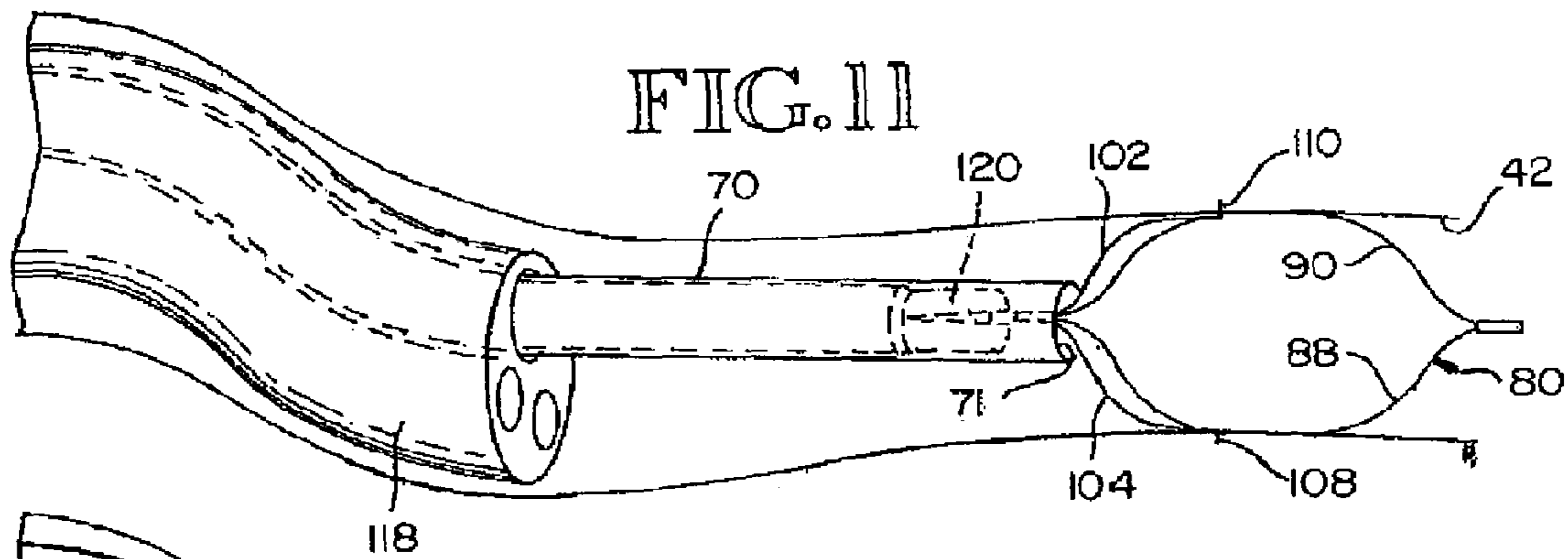
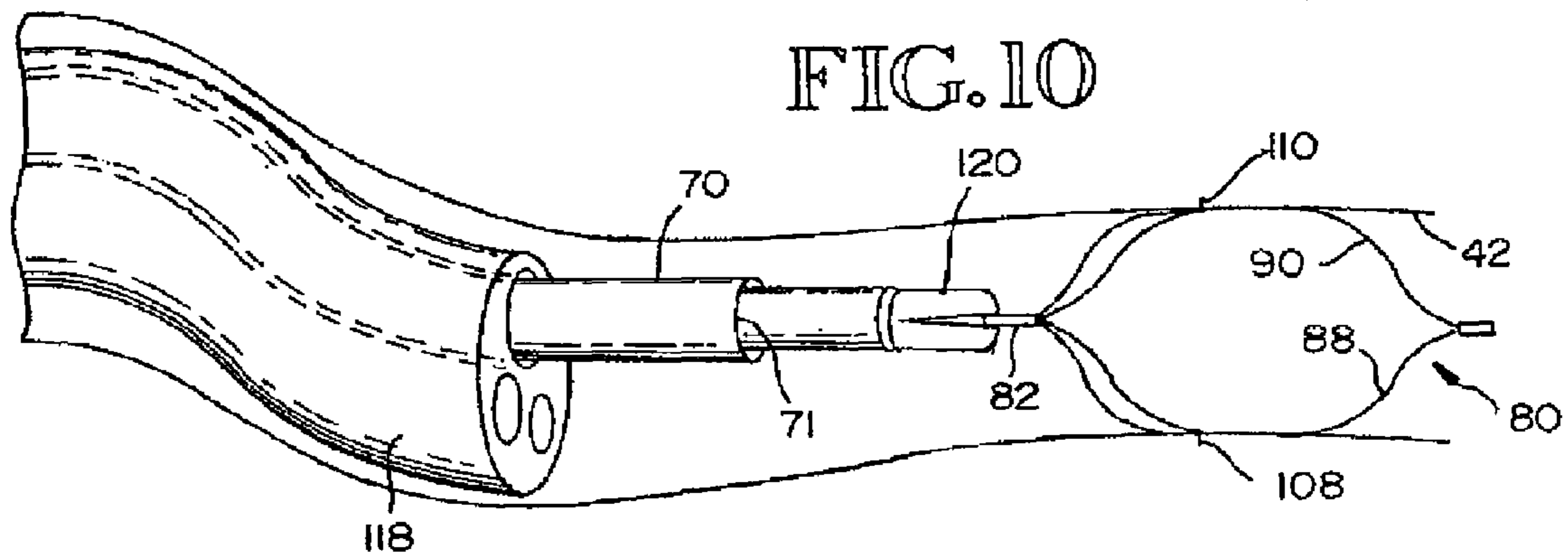

FIG. 9







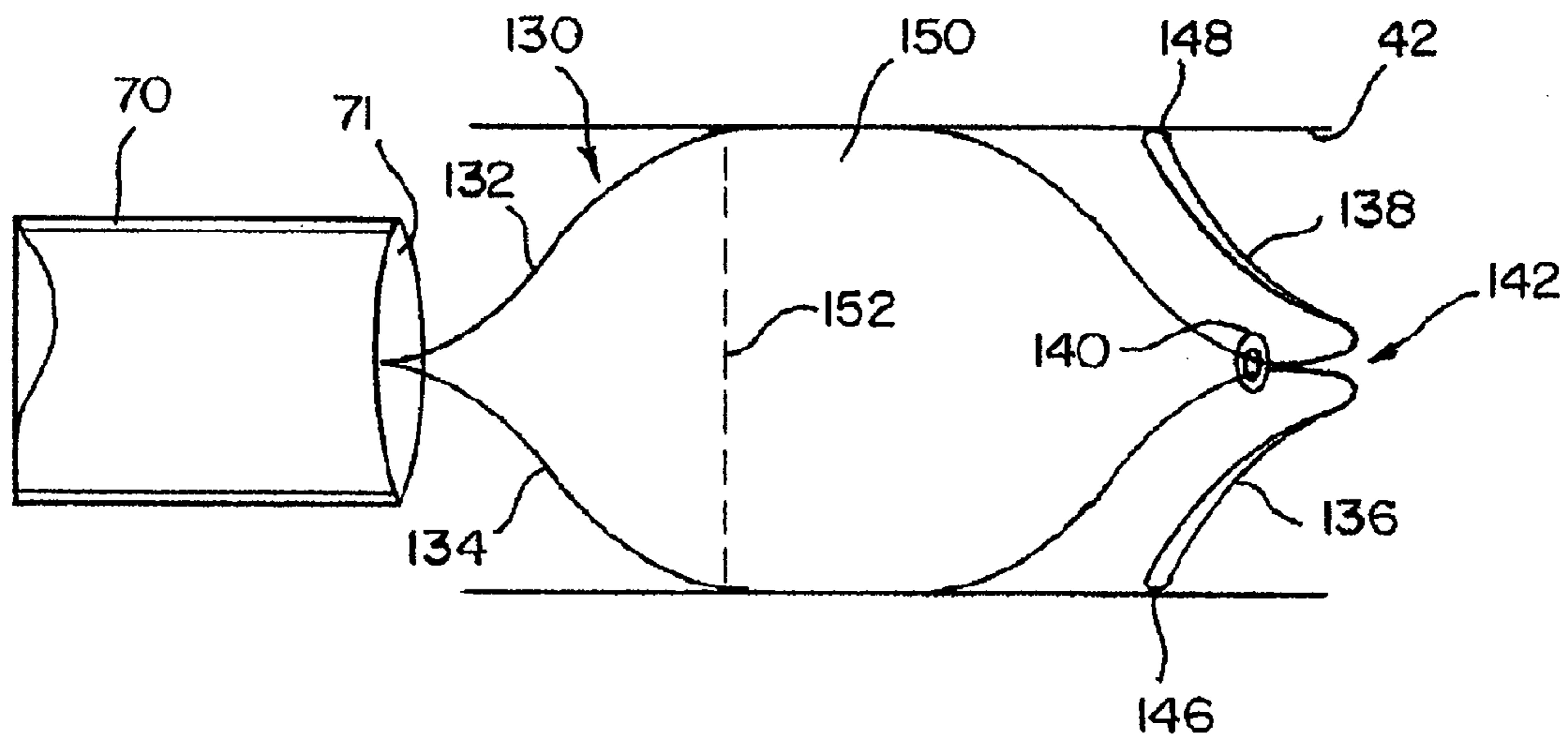

FIG. 13

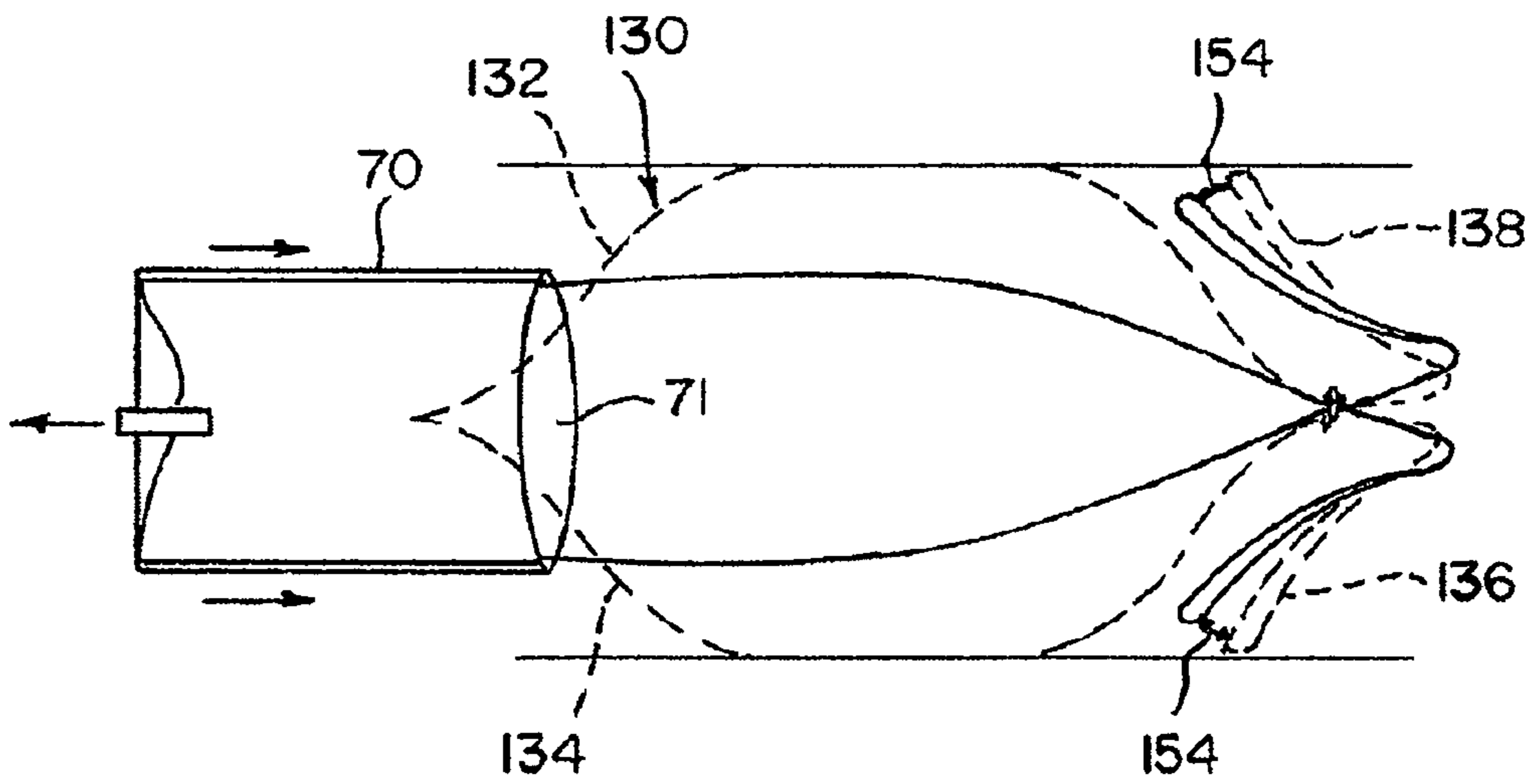

FIG. 14

FIG. 15

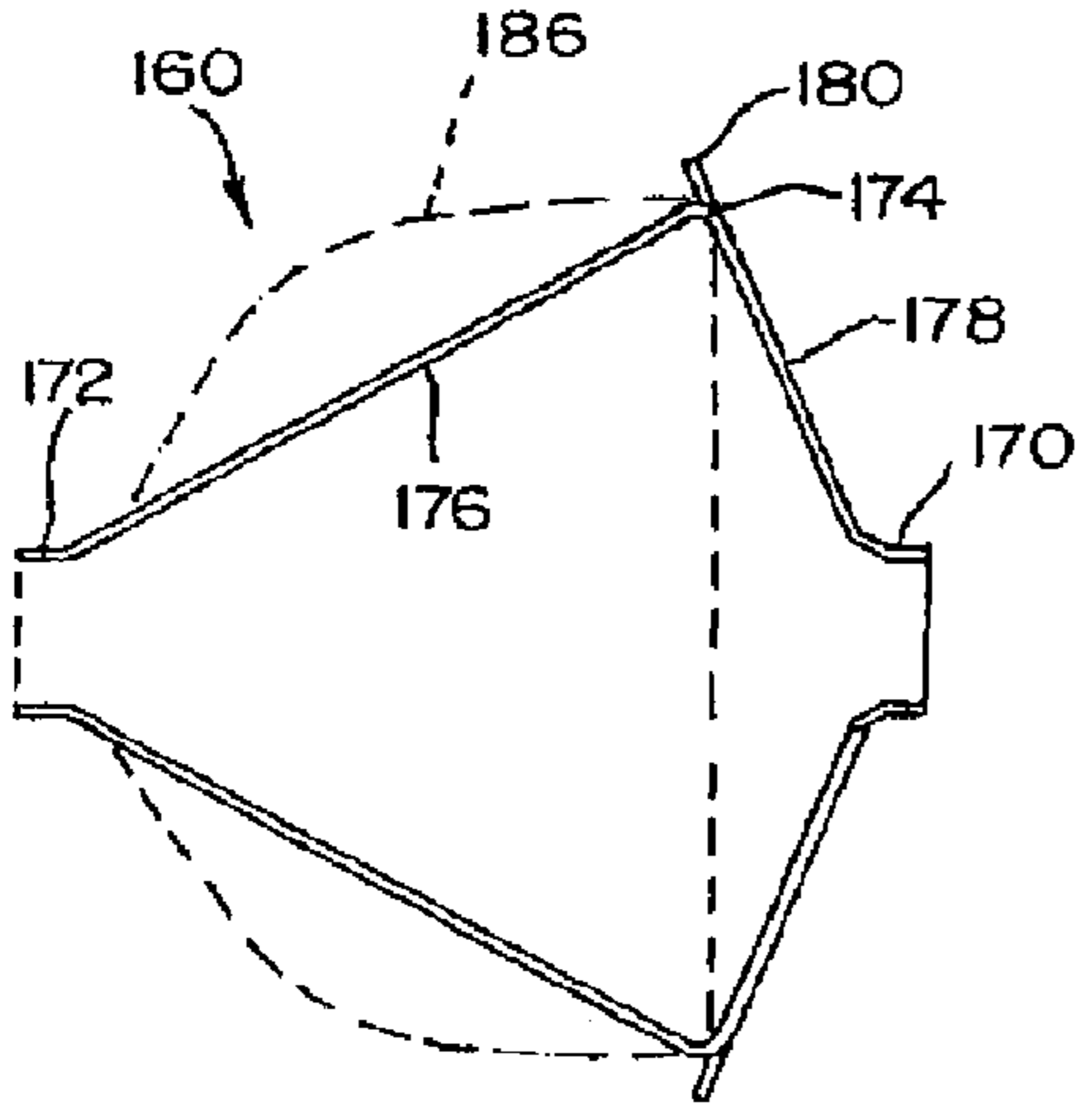
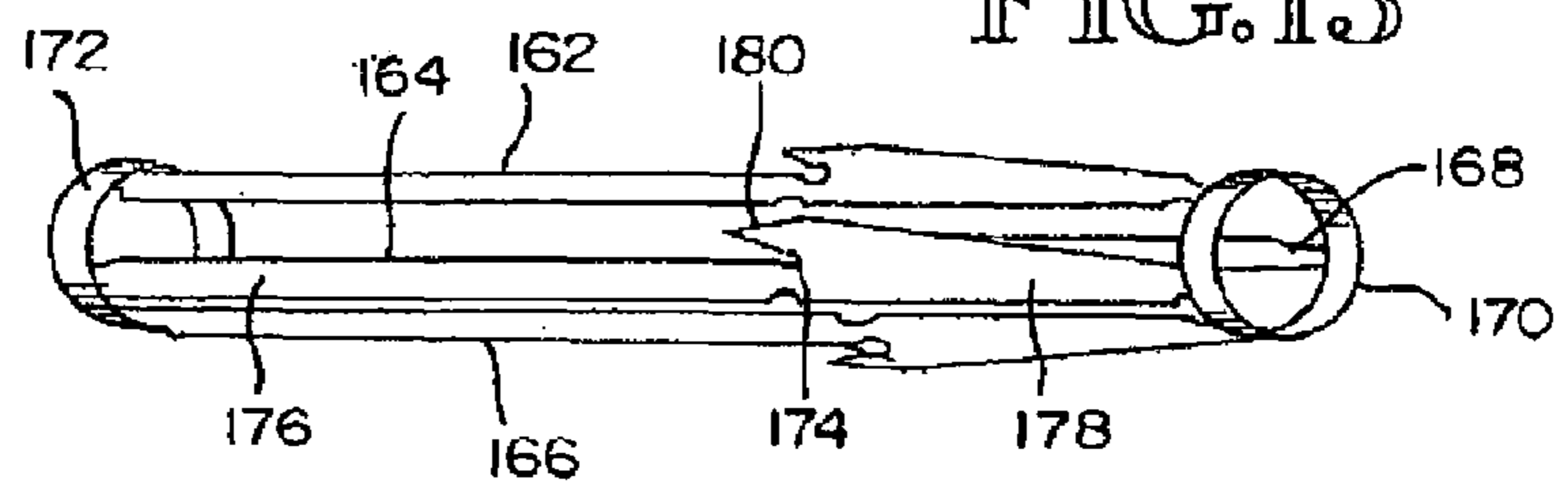

FIG. 16

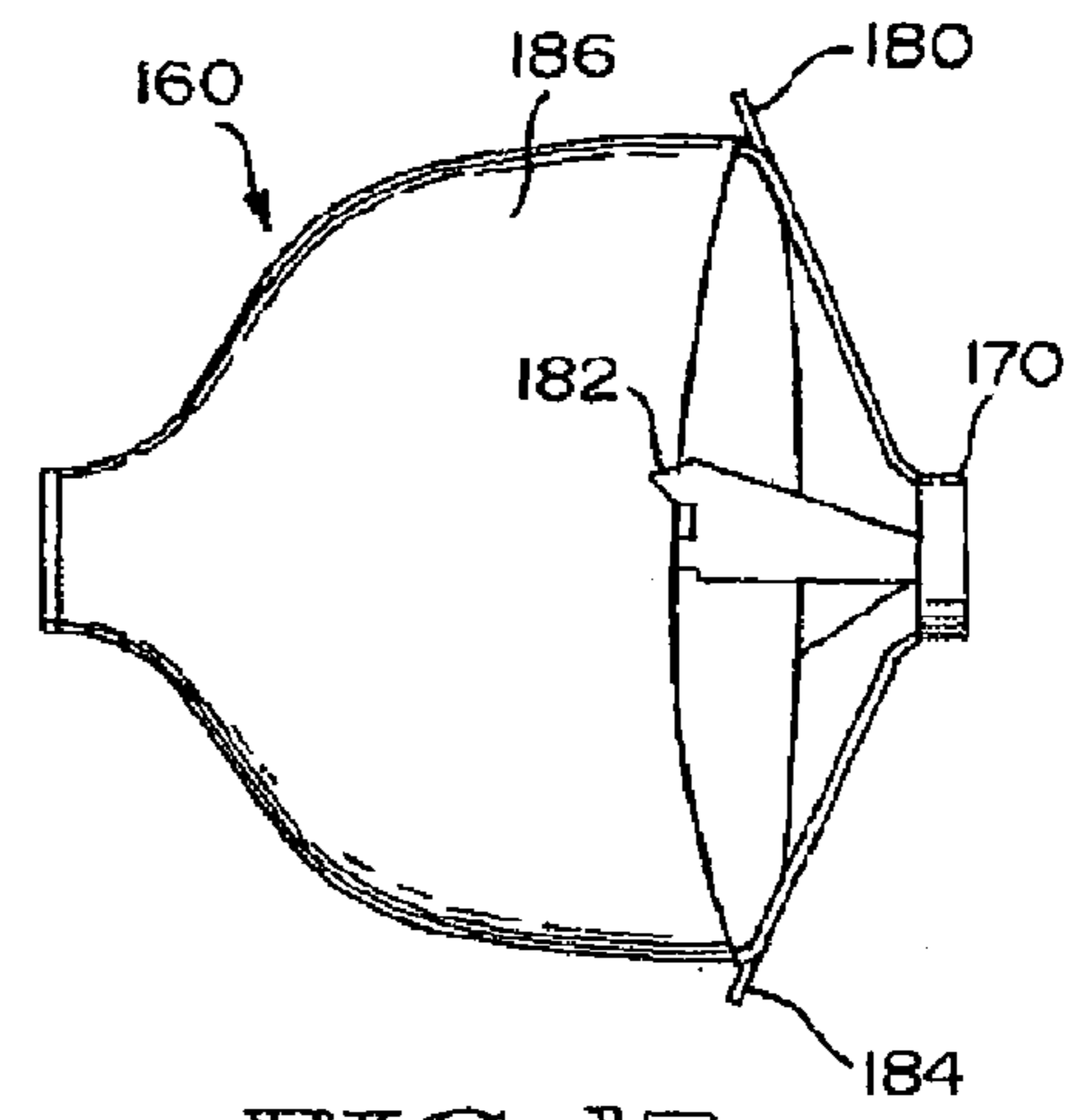

FIG. 17

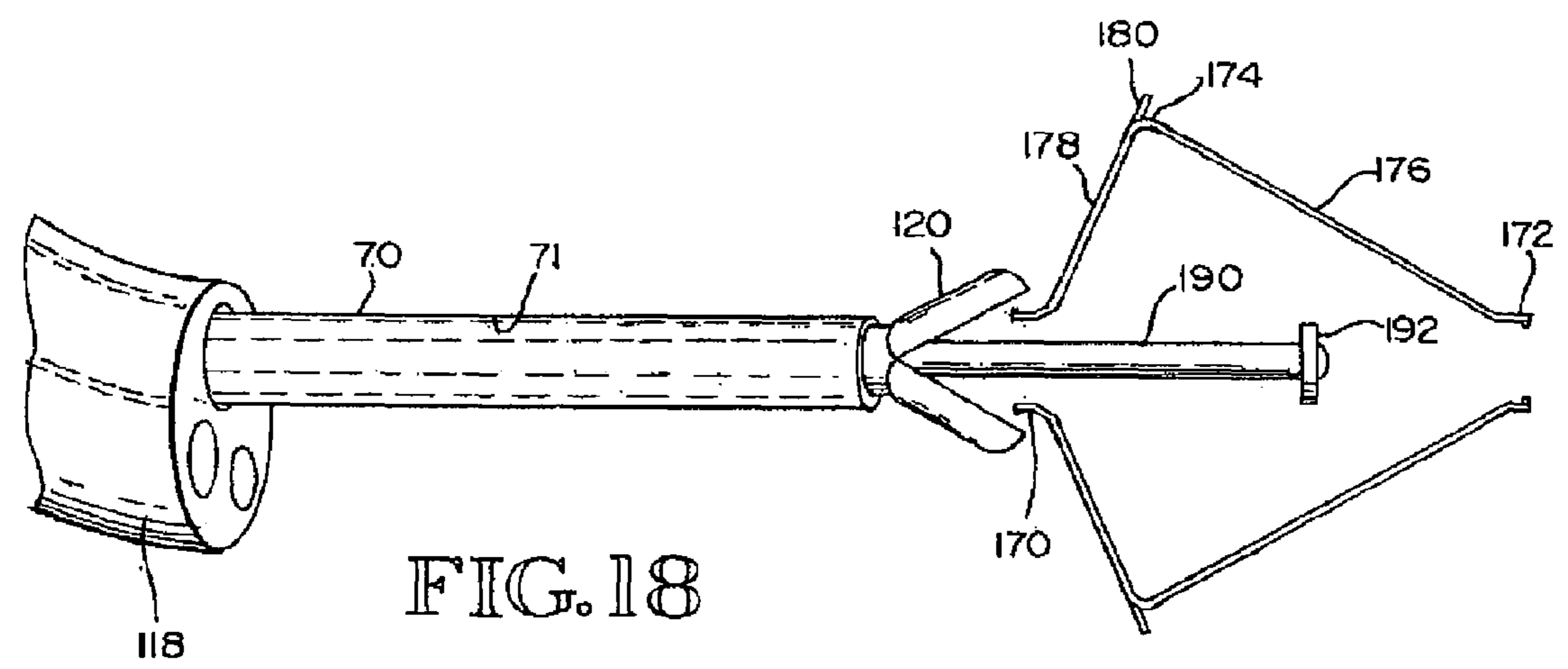
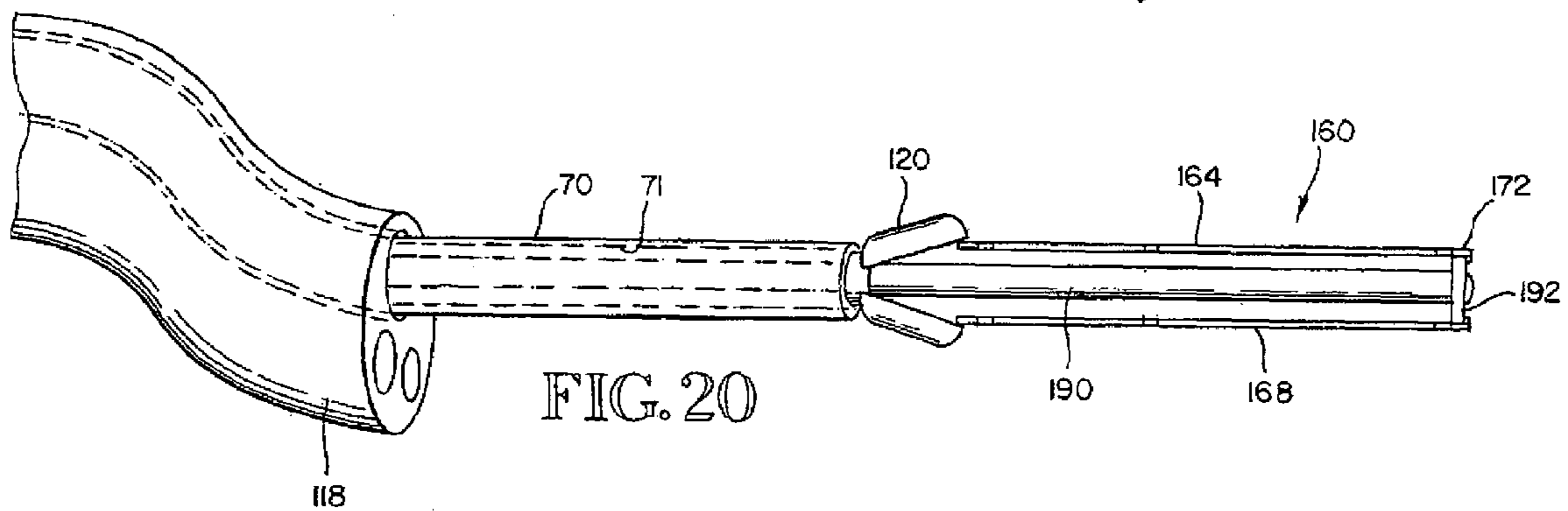
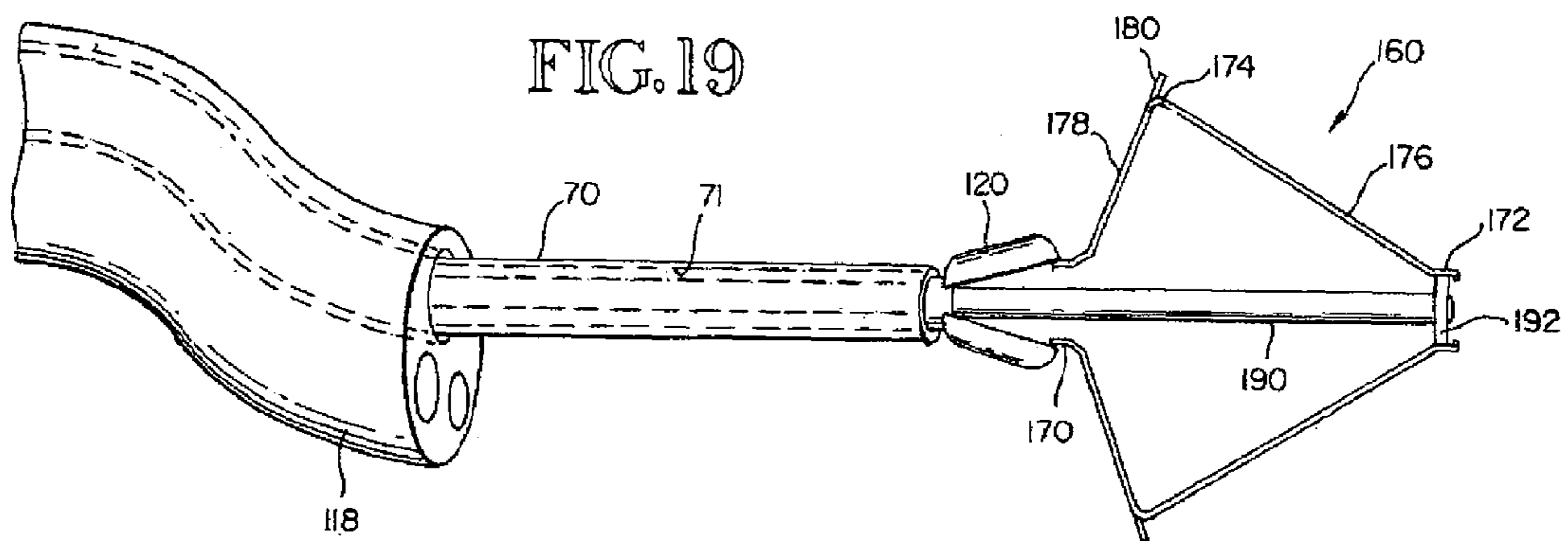

FIG. 18



## REMOVABLE LUNG REDUCTION DEVICES, SYSTEMS, AND METHODS

### CROSS REFERENCE TO RELATED APPLICATIONS

This application is a continuation of U.S. application Ser. No. 12/428,287, now U.S. Pat. No. 7,757,692, filed Apr. 22, 2009, which is a continuation of U.S. application Ser. No. 10/847,554, filed May 17, 2004, now abandoned which is a divisional of U.S. application Ser. No. 09/951,105, filed Sep. 11, 2001, now abandoned each of which is hereby incorporated herein by reference in its entirety.

### BACKGROUND OF THE INVENTION

The present invention is generally directed to a treatment of Chronic Obstructive Pulmonary Disease (COPD). The present invention is more particularly directed to removable air passageway obstruction devices, and systems and methods for removing the devices.

Chronic Obstructive Pulmonary Disease (COPD) has become a major cause of morbidity and mortality in the United States over the last three decades. COPD is characterized by the presence of airflow obstruction due to chronic bronchitis or emphysema. The airflow obstruction in COPD is due largely to structural abnormalities in the smaller airways. Important causes are inflammation, fibrosis, goblet cell metaplasia, and smooth muscle hypertrophy in terminal bronchioles.

The incidence, prevalence, and health-related costs of COPD are on the rise. Mortality due to COPD is also on the rise. In 1991 COPD was the fourth leading cause of death in the United States and had increased 33% since 1979.

COPD affects the patients whole life. It has three main symptoms: cough; breathlessness; and wheeze. At first, breathlessness may be noticed when running for a bus, digging in the garden, or walking up hill. Later, it may be noticed when simply walking in the kitchen. Over time, it may occur with less and less effort until it is present all of the time.

COPD is a progressive disease and currently has no cure. Current treatments for COPD include the prevention of further respiratory damage, pharmacotherapy, and surgery. Each is discussed below.

The prevention of further respiratory damage entails the adoption of a healthy lifestyle. Smoking cessation is believed to be the single most important therapeutic intervention. However, regular exercise and weight control are also important. Patients whose symptoms restrict their daily activities or who otherwise have an impaired quality of life may require a pulmonary rehabilitation program including ventilatory muscle training and breathing retraining. Long-term oxygen therapy may also become necessary.

Pharmacotherapy may include bronchodilator therapy to open up the airways as much as possible or inhaled .beta.-agonists. For those patients who respond poorly to the foregoing or who have persistent symptoms, Ipratropium bromide may be indicated. Further, courses of steroids, such as corticosteroids, may be required. Lastly, antibiotics may be required to prevent infections and influenza and pneumococcal vaccines may be routinely administered. Unfortunately, there is no evidence that early, regular use of pharmacotherapy will alter the progression of COPD.

About 40 years ago, it was first postulated that the tethering force that tends to keep the intrathoracic airways open was lost in emphysema and that by surgically removing the most

affected parts of the lungs, the force could be partially restored. Although the surgery was deemed promising, the procedure was abandoned.

The lung volume reduction surgery (LVRS) was later revived. In the early 1990's, hundreds of patients underwent the procedure. However, the procedure has fallen out of favor due to the fact that Medicare stopped reimbursing for LVRS. Unfortunately, data is relatively scarce and many factors conspire to make what data exists difficult to interpret. The procedure is currently under review in a controlled clinical trial. What data does exist tends to indicate that patients benefited from the procedure in terms of an increase in forced expiratory volume, a decrease in total lung capacity, and a significant improvement in lung function, dyspnea, and quality of life. However, the surgery is not without potential complications. Lung tissue is very thin and fragile. Hence, it is difficult to suture after sectioning. This gives rise to potential infection and air leaks. In fact, nearly thirty percent (30%) of such surgeries result in air leaks.

Improvements in pulmonary function after LVRS have been attributed to at least four possible mechanisms. These include enhanced elastic recoil, correction of ventilation/perfusion mismatch, improved efficiency of respiratory musculature, and improved right ventricular filling.

Lastly, lung transplantation is also an option. Today, COPD is the most common diagnosis for which lung transplantation is considered. Unfortunately, this consideration is given for only those with advanced COPD. Given the limited availability of donor organs, lung transplant is far from being available to all patients.

In view of the need in the art for new and improved therapies for COPD which provide more permanent results than pharmacotherapy while being less invasive and traumatic than LVRS, at least two new therapies have recently been proposed.

Both of these new therapies provide lung size reduction by permanently collapsing at least a portion of a lung.

In accordance with a first one of these therapies, and as described in U.S. Pat. No. 6,258,100 assigned to the assignee of the present invention and incorporated herein by reference, a lung may be collapsed by obstructing an air passageway communicating with the lung portion to be collapsed. The air passageway may be obstructed by placing an obstructing member in the air passageway. The obstructing member may be a plug-like device which precludes air flow in both directions or a one-way valve which permits air to be exhaled from the lung portion to be collapsed while precluding air from being inhaled into the lung portion. Once the air passageway is sealed, the residual air within the lung will be absorbed over time to cause the lung portion to collapse.

As further described in U.S. Pat. No. 6,258,100, the lung portion may be collapsed by inserting a conduit into the air passageway communicating with the lung portion to be collapsed. An obstruction device, such as a one-way valve is then advanced down the conduit into the air passageway. The obstruction device is then deployed in the air passageway for sealing the air passageway and causing the lung portion to be collapsed.

The second therapy is fully described in copending U.S. application Ser. No. 09/534,244, filed Mar. 23, 2000, for LUNG CONSTRICTION APPARATUS AND METHOD and, is also assigned to the assignee of the present invention. As described therein, a lung constriction device including a sleeve of elastic material is configured to cover at least a portion of a lung. The sleeve has a pair of opened ends to permit the lung portion to be drawn into the sleeve. Once

drawn therein, the lung portion is constricted by the sleeve to reduce the size of the lung portion.

Both therapies hold great promise for treating COPD. Neither therapy requires sectioning and suturing of lung tissue.

While either therapy alone would be effective in providing lung size reduction and treatment of COPD, it has recently been proposed that the therapies may be combined for more effective treatment. More specifically, it has been proposed that the therapies could be administered in series, with the first mentioned therapy first applied acutely for evaluation of the effectiveness of lung size reduction in a patient and which lung portions should be reduced in size to obtain the best results. The first therapy is ideal for this as it is noninvasive and could be administered in a physician's office. Once the effectiveness of lung size reduction is confirmed and the identity of the lung portions to be collapsed is determined, the more invasive second mentioned therapy may be administered.

In order to combine these therapies, or simply administer the first therapy for evaluation, it will be necessary for at least some of the deployed air passageway obstruction devices to be removable. Unfortunately, such devices as currently known in the art are not suited for removal. While such devices are expandable for permanent deployment, such devices are not configured or adapted for recollapse after having once been deployed in an air passageway to facilitate removal. Hence, there is a need in the art for air passageway obstruction devices which are removable after having been deployed and systems and methods for removing them.

#### SUMMARY OF THE INVENTION

The invention provides device for reducing the size of a lung comprising an obstructing structure dimensioned for insertion into an air passageway communicating with a portion of the lung to be reduced in size, the obstructing structure having an outer dimension which is so dimensioned when deployed in the air passageway to preclude air from flowing into the lung portion to collapse the portion of the lung for reducing the size of the lung, the obstructing structure being collapsible to permit removal of the obstruction device from the air passageway.

The invention further provides an assembly comprising a device for reducing the size of a lung, the device being dimensioned for insertion into an air passageway communicating with a portion of the lung to be reduced in size, the device having an outer dimension which is so dimensioned when deployed in the air passageway to preclude air from flowing into the lung portion to collapse the portion of the lung for reducing the size of the lung, a catheter having an internal lumen and being configured to be passed down a trachea, into the air passageway, and a retractor dimensioned to be passed down the internal lumen of the catheter, seizing the device, and pulling the obstruction device proximally into the internal lumen to remove the device from the air passageway. The device is collapsible after having been deployed to permit the device to be pulled proximally into the internal lumen of the catheter by the retractor.

The invention further provides a method of removing a deployed air passageway obstruction device from an air passageway in which the device is deployed. The method includes the steps of passing a catheter, having an internal lumen, down a trachea and into the air passageway, advancing a retractor down the internal lumen of the catheter to the device, seizing the device with the retractor, collapsing the device to free the device from deployment in the air passage-

way, and pulling the device with the retractor proximally into the internal lumen of the catheter.

The invention still further provides an air passageway obstruction device comprising a frame structure, and a flexible membrane overlying the frame structure. The frame structure is collapsible upon advancement of the device into the air passageway, expandable into a rigid structure upon deployment in the air passageway whereby the flexible membrane obstructs inhaled air flow into a lung portion communicating with the air passageway, and re-collapsible upon removal from the air passageway.

The invention still further provides an air passageway obstruction device comprising frame means for forming a support structure, and flexible membrane means overlying the support structure. The frame means is expandable to an expanded state within an air passageway to position the membrane means for obstructing air flow within the air passageway and is collapsible for removal of the device from the air passageway.

#### BRIEF DESCRIPTION OF THE DRAWINGS

The features of the present invention which are believed to be novel are set forth with particularity in the appended claims. The invention, together with further objects and advantages thereof, may best be understood by making reference to the following description taken in conjunction with the accompanying drawings, in the several figures of which like referenced numerals identify identical elements, and wherein:

FIG. 1 is a simplified sectional view of a thorax illustrating a healthy respiratory system;

FIG. 2 is a sectional view similar to FIG. 1 but illustrating a respiratory system suffering from COPD and the execution of a first step in treating the COPD condition in accordance with the present invention;

FIG. 3 is a perspective view, illustrating the frame structure of a removable air passageway obstruction device embodying the present invention;

FIG. 4 is a perspective view of the complete air passageway obstruction device of FIG. 3;

FIG. 5 is an end view of the device of FIG. 3 illustrating its operation for obstructing inhaled air flow;

FIG. 6 is another end view of the device of FIG. 3 illustrating its operation for permitting exhaled air flow;

FIG. 7 is a perspective view of the device of FIG. 3, illustrating its operation for permitting partial exhaled air flow;

FIG. 8 is a side view illustrating a first step in removing the device of FIG. 3 in accordance with one embodiment of the present invention;

FIG. 9 is another side view illustrating the collapse of the device of FIG. 3 as it is removed from an air passageway;

FIG. 10 is a side view illustrating an initial step in the removal of the device of FIG. 3 in accordance with another embodiment of the present invention;

FIG. 11 is a side view illustrating engagement of the frame structure of the device with a catheter during removal of the device;

FIG. 12 is a side view illustrating the collapse of the device by the catheter during removal of the device;

FIG. 13 is a side view of another air passageway obstruction device embodying the present invention during an initial step in its removal from an air passageway;

FIG. 14 is another side view of the device of FIG. 13 illustrating its collapse during removal from the air passageway;

5

FIG. 15 is a perspective view of the frame structure of another removable air passageway obstruction device embodying the present invention;

FIG. 16 is a cross-sectional side view of the device of FIG. 15 shown in a deployed state;

FIG. 17 is a perspective side view of the device of FIG. 15 shown in a deployed state;

FIG. 18 is a side view illustrating an initial step in removing the device of FIG. 15 from an air passageway;

FIG. 19 is a side view illustrating an intermediate step in the removal of the device of FIG. 15; and

FIG. 20 is a side view illustrating the collapse of the device of FIG. 15 during its removal from an air passageway.

#### DETAILED DESCRIPTION OF THE PREFERRED EMBODIMENTS

Referring now to FIG. 1, it is a sectional view of a healthy respiratory system. The respiratory system 20 resides within the thorax 22 which occupies a space defined by the chest wall 24 and the diaphragm 26.

The respiratory system 20 includes the trachea 28, the left mainstem bronchus 30, the right mainstem bronchus 32, the bronchial branches 34, 36, 38, 40, and 42 and sub-branches 44, 46, 48, and 50. The respiratory system 20 further includes left lung lobes 52 and 54 and right lung lobes 56, 58, and 60. Each bronchial branch and sub-branch communicates with a respective different portion of a lung lobe, either the entire lung lobe or a portion thereof. As used herein, the term "air passageway" is meant to denote either a bronchial branch or sub-branch which communicates with a corresponding individual lung lobe or lung lobe portion to provide inhaled air thereto or conduct exhaled air therefrom.

Characteristic of a healthy respiratory system is the arched or inwardly arcuate diaphragm 26. As the individual inhales, the diaphragm 26 straightens to increase the volume of the thorax 22. This causes a negative pressure within the thorax. The negative pressure within the thorax in turn causes the lung lobes to fill with air. When the individual exhales, the diaphragm returns to its original arched condition to decrease the volume of the thorax. The decreased volume of the thorax causes a positive pressure within the thorax which in turn causes exhalation of the lung lobes.

In contrast to the healthy respiratory system of FIG. 1, FIG. 2 illustrates a respiratory system suffering from COPD. Here it may be seen that the lung lobes 52, 54, 56, 58, and 60 are enlarged and that the diaphragm 26 is not arched but substantially straight. Hence, this individual is incapable of breathing normally by moving the diaphragm 26. Instead, in order to create the negative pressure in the thorax 22 required for breathing, this individual must move the chest wall outwardly to increase the volume of the thorax. This results in inefficient breathing causing these individuals to breathe rapidly with shallow breaths. It has been found that the apex portion 62 and 66 of the upper lung lobes 52 and 56, respectively, are most affected by COPD.

In accordance with this embodiment of the present invention, COPD treatment or evaluation is initiated by feeding a conduit or catheter 70 down the trachea 28, into a mainstream bronchus such as the right mainstem bronchus 32, and into an air passageway such as the bronchial branch 42 or the bronchial sub-branch 50. An air passageway obstruction device embodying the present invention is then advanced down an internal lumen 71 of the catheter 70 for deployment in the air passageway. Once deployed, the obstruction device precludes inhaled air from entering the lung portion to be collapsed. In accordance with the present invention, it is preferable that the

6

obstruction device take the form of a one-way valve. In addition to precluding inhaled air from entering the lung portion, the device further allows air within the lung portion to be exhaled. This results in more rapid collapse of the lung portion. However, obstruction devices which preclude both inhaled and exhaled air flow are contemplated as falling within the scope of the invention.

The catheter 70 is preferably formed of flexible material such as polyethylene. Also, the catheter 70 is preferably performed with a bend 72 to assist the feeding of the catheter from the right mainstem bronchus 32 into the bronchial branch 42.

FIGS. 3 and 4 show an air passageway obstruction device 80 embodying the present invention. The device 80 includes a proximal end 82 and a distal end 84. The device 80 further includes a frame structure 86 including frame supports 88, 90, and 92.

Each of the frame supports has a shape to define a generally cylindrical center portion 94 and a pair of oppositely extending inwardly arcuate conical end portions 96 and 98. The frame structure further includes a plurality of fixation members 100, 102, and 104 which extend distally from the proximal end 82. The fixation members have the generally conical shape and terminate in fixation projections or anchors 106, 108, and 110 which extend radially outwardly.

Overlying and partially enclosing the frame structure 86 is a flexible membrane 112. The flexible membrane extends over the generally cylindrical and conical portions 94 and 98 defined by the frame structure. Hence, the flexible membrane is opened in the proximal direction.

The flexible membrane may be formed of silicone or polyurethane, for example. It may be secured to the frame structure in a manner known in the art such as by crimping, riveting, or adhesion.

The frame structure 86 and the device 80 are illustrated in FIGS. 3 and 4 as the device would appear when fully deployed in an air passageway. The frame structure supports and frame structure fixation members are preferably formed of stainless steel or Nitinol or other suitable material which has memory of an original shape. The frame structure permits the device to be collapsed for advancement down the internal lumen 71 of the catheter 70 into the air passageway where the device is to be deployed. Once the point of deployment is reached, the device is expelled from the catheter to assume its original shape in the air passageway. In doing so, the generally cylindrical portion 94 contacts the inner wall of the air passageway and the fixation projections 106, 108, and 110 pierce the wall of the air passageway for fixing or anchoring the device 80 within the air passageway.

When the device 80 is deployed, the frame structure 86 and flexible membrane 112 form an obstructing structure or one-way valve. FIGS. 5 and 6 show the valve action of the device 80 when deployed in an air passageway, such as the bronchial branch 42.

As shown in FIG. 5, during inhalation, the flexible membrane is filled with air and expands outwardly to obstruct the air passageway 42. This precludes air from entering the lung portion being collapsed. However, as shown in FIG. 6, during expiration, the flexible membrane 112 deflects inwardly to only partially obstruct the air passageway 42. This enables air, which may be in the lung portion being collapsed, to be exhaled for more rapid collapse of the lung portion. FIG. 7 is another view showing the device 80 during expiration with a portion 114 of the membrane 112 deflected inwardly.

FIGS. 8 and 9 illustrate a manner in which the device 80 may be removed from the air passageway 42 in accordance with one embodiment of the present invention. As previously

mentioned, it may be desired to remove the device **80** if it is only used for evaluating the effectiveness of collapsing a lung portion or if it is found the more effective treatment may be had with the collapse of other lung portions.

The device **80** is shown in FIG. **8** in a fully deployed state. The catheter **70** having the internal lumen **71** is advanced to the proximal end of the device **80**. In FIG. **8** it may be noted that the fixation members **102** and **104** define a larger conical radius than the frame supports **88** and **90**. Hence, when the proximal end of the device is engaged by a retractor and the catheter **70** is moved distally as shown in FIG. **9**, the internal lumen of the catheter engages the fixation members **102** and **104** before it engages the frame supports **88** and **90**. This causes the fixation projections to first disengage the inner wall of the air passageway **42**. With the device now free of the air passageway side wall, the retractor may be used to pull the device into the internal lumen **71** of the catheter **70** causing the support structure and thus the device to collapse. The collapsed device may now fully enter the internal lumen of the catheter for removal.

FIGS. **10-12** show another embodiment of the present invention for removing the device **80** from the air passageway **42**. Here, the catheter **70** is fed down a bronchoscope **118** to the device **80**. The retractor takes the form of a forceps **120**.

In FIG. **10** it may be seen that the forceps has just engaged the proximal end **82** of the device **80**. In FIG. **11** the forceps **120** is held stationary while the catheter **70** is advanced distally so that the internal lumen **71** of the catheter **70** engages the fixation members **102** and **104**. Further advancement of the catheter **70** as seen in FIG. **12** deflects the fixation projections **110** and **108** inwardly away from the inner wall of the air passageway **42**. Now, the forceps may be used to pull the device **80** into the internal lumen **71** of the catheter **70** for removal of the device **80** from the air passageway **42**.

FIGS. **13** and **14** show another removable air passageway obstruction device **130** and a method of removing it from an air passageway in accordance with the present invention. The device **130** is shown in FIG. **13** deployed in the air passageway **42** and the catheter **70** is in ready position to remove the device **130** from the air passageway **42**.

The device **130** is of similar configuration to the device **80** previously described. Here however, the fixation members **136** and **138** are extensions of the frame supports **132** and **134**, respectively. To that end, it will be noted in FIG. **13** that the frame supports **132** and **134** cross at a pivot point **140** at the distal end **142** of the device **130**. They extend distally and then are turned back at an acute angle to terminate at fixation or anchor ends **146** and **148**. When the device is deployed as shown in FIG. **13**, the cylindrical portions of the support frame engage the inner wall of the air passageway **42** and the fixation points **146** and **148** project into the inner wall of the air passageway **42** to maintain the device in a fixed position. The flexible membrane **150** extends from the dashed line **152** to the pivot or crossing point **140** of the frame supports **132** and **134** to form a one-way valve.

When the device is to be removed, the frame structure of the device **130** is held stationary by a retractor within the catheter **70** and the catheter is advanced distally. When the catheter **70** engages the frame supports **132** and **134**, the frame supports are deflected inwardly from their dashed line positions to their solid line positions. This also causes the fixation members **136** and **138** to be deflected inwardly from their dashed line positions to their solid line positions in the direction of arrows **154**. These actions disengage the device **130** from the inner wall of the air passageway **42**. Now, the

retractor may pull the device into the internal lumen **71** of the catheter **70** for removal of the device **130** from the air passageway **42**.

FIGS. **15-17** show a still further removable air passageway obstruction device **160** embodying the present invention. As shown in the initial collapsed state in FIG. **15**, the device **160** includes a plurality of frame supports **162**, **164**, **166**, and **168**. The frame supports extend between a proximal ring **170** and a distal ring **172**. The device **160** is preferably laser cut from a sheet of Nitinol.

Since each of the frame supports are identical, only frame support **164** will be described herein. As will be noted, the support **164** includes a bend point **174** with a relatively long section **176** extending distally from the bend point **174** and a relatively short section **178** extending proximally from the bend point **174**. The short section **178** includes a fixation projection or anchor **180** extending slightly distally from the bend point **174**.

FIGS. **16** and **17** show the device **160** in its deployed configuration. When the device is deployed, it is advanced down a catheter to its deployment site in its collapsed state as shown in FIG. **15**. When the deployment site is reached, the device **160** is held outside of the catheter and the rings **170** and **172** are pulled toward each other. This causes the device to bend at the bend points of the frame supports. This forms fixation projections **180**, **182**, and **184** extending into the inner wall of the air passageway to fix the device in position.

The relatively long sections of the frame supports are covered with a flexible membrane **186** as shown in FIGS. **16** and **17** to form a one-way valve. The valve functions as previously described to obstruct inhaled air flow but to permit exhaled air flow.

FIGS. **18-20** illustrate a manner of removing the device **160** from an air passageway. Once again a catheter **70** is advanced down a bronchoscope **118** to the device **160**. Next, a retractor including a forceps **120** and pin **190** are advanced to the device. The pin **190**, carrying a larger diameter disk **192**, extends into the device as the forceps **120** grasps the proximal ring **170** of the device **160**. The pin **190** continues to advance until the disk **192** engages the distal ring **172** of the device **160** as shown in FIG. **19**. Then, while the forceps **120** holds the proximal ring **170**, the pin **190** and disk **192** are advanced distally carrying the distal ring **172** distally. This causes the device **160** to straighten and collapse as shown in FIG. **20**. Now, the forceps **120**, pin **190**, and the device **160** may be pulled into the internal lumen **71** of the catheter **70** for removal of the device. As will be appreciated by those skilled in the art, the foregoing steps may be reversed for deploying the device **160**.

While particular embodiments of the present invention have been shown and described, modifications may be made, and it is therefore intended in the appended claims to cover all such changes and modifications which fall within the true spirit and scope of the invention.

What is claimed is:

1. A method of moving a device in an air passageway, wherein the device comprises a flexible frame with at least one frame support, the frame support further comprising at least one fixation projection configured to extend inwardly into the air passageway while deployed, wherein the at least one fixation projection is configured to release from the air passageway when pulled in a proximal direction, the method of moving the device comprising:
  - 65 advancing a catheter through a trachea and into the air passageway, the catheter having at least one internal lumen;



9

advancing a retractor through the internal lumen of the catheter to the device;  
 grasping a portion of the device with the retractor;  
 collapsing the device to free the device from deployment in the air passageway; and  
 advancing the catheter over at least a portion of the retractor and a proximal end of the device; and  
 withdrawing the catheter from the air passageway and trachea.

2. The method of moving the device of claim 1, wherein the device further comprises a proximal portion located in an axially-central location, and wherein grasping comprises grasping the proximal section of the device with the retractor.

3. The method of moving the device of claim 1, wherein the step of collapsing the device releases the at least one fixation projection from the air passageway.

4. The method of moving the device of claim 1, wherein the device is collapsible so as to fit within the internal lumen of the catheter.

5. The method of moving the device of claim 1, wherein the device further comprises a membrane configured to contact an air passageway wall.

6. The method of moving the device of claim 1, further comprising pulling the device and retractor proximally into the internal lumen of the catheter after collapsing the device.

7. The method of moving the device of claim 1, further comprising the step of removing the device from the air passageway.

8. A kit for moving a device, the device being collapsible and dimensioned for insertion into an air passageway communicating with a portion of a lung to be treated, the device being movable from a collapsed position to a deployed position, the device further comprising at least one anchor configured to engage the air passageway when the device is in a deployed position, and wherein the at least one anchor is

10

configured to release from the air passageway when pulled in a proximal direction, and wherein the kit comprises:

a catheter having an internal lumen and being dimensioned to fit within the air passageway; and

a retractor configured to fit within the internal lumen of the catheter and comprising at a distal end a member for engaging the device to remove the device from the air passageway.

9. The kit of claim 8, wherein the retractor is configured to pull the device proximally into the internal lumen of the catheter.

10. The kit of claim 9, wherein the catheter is configured to collapse the device as the device is pulled into the internal lumen of the catheter.

11. The kit of claim 8, wherein the device comprises at least one anchor is disposed at a distal end.

12. The kit of claim 8, wherein the device forms a one-way valve.

13. The kit of claim 8, wherein the device comprises a collapsible frame and a flexible membrane overlying the collapsible frame.

14. The kit of claim 13, wherein the device has an open proximal end and a closed distal end.

15. The kit of claim 14, wherein the flexible membrane is configured to preclude air from flowing into the lung portion by at least partially inflating in response to air flowing in a distal direction, and wherein the flexible membrane is configured to permit air to flow out of the lung portion by at least partially deflating in response to air flowing in a proximal direction.

16. The kit of claim 8, wherein the retractor is configured to engage a centrally-located proximal rod on the device.

17. The kit of claim 8, wherein the retractor is a forceps.

18. The kit of claim 8, wherein the catheter is dimensioned to fit within a bronchoscope.

\* \* \* \* \*