



US008414528B2

(12) **United States Patent**
Liu et al.

(10) **Patent No.:** **US 8,414,528 B2**
(45) **Date of Patent:** **Apr. 9, 2013**

- (54) **POLYMER SCAFFOLD SHEATHS**
- (75) Inventors: **Annie P. Liu**, Cupertino, CA (US);
Jason Phillips, Lake Elsinore, CA (US);
Mark C. Johnson, Murrieta, CA (US);
Sean McNiven, San Francisco, CA (US)
- (73) Assignee: **Abbott Cardiovascular Systems Inc.**,
Santa Clara, CA (US)
- (*) Notice: Subject to any disclaimer, the term of this
patent is extended or adjusted under 35
U.S.C. 154(b) by 0 days.

5,653,697 A	8/1997	Quiachon et al.
5,693,066 A	12/1997	Rupp et al.
5,709,703 A	1/1998	Lukic et al.
5,749,852 A	5/1998	Schwab et al.
5,765,682 A	6/1998	Bley et al.
5,776,141 A	7/1998	Klein et al.
5,782,855 A	7/1998	Lau et al.
5,817,100 A	10/1998	Igaki
5,868,707 A	2/1999	Williams et al.
5,893,868 A	4/1999	Holman et al.
5,964,730 A	10/1999	Williams et al.
6,010,529 A	1/2000	Herweck et al.
6,110,146 A	8/2000	Berthiaume et al.
6,132,450 A	10/2000	Hanson et al.
6,152,944 A	11/2000	Holman et al.
6,197,016 B1	3/2001	Fourkas et al.

(21) Appl. No.: **13/118,311**

(Continued)

(22) Filed: **May 27, 2011**

FOREIGN PATENT DOCUMENTS

(65) **Prior Publication Data**
US 2012/0302955 A1 Nov. 29, 2012

WO	WO 98/39056	9/1998
WO	WO 02/060345	8/2002
WO	WO 2011/094048	8/2011

- (51) **Int. Cl.**
A61M 25/00 (2006.01)
- (52) **U.S. Cl.** **604/103.05**
- (58) **Field of Classification Search** 604/103.05,
604/160, 161; 623/1.11, 1.12
See application file for complete search history.

OTHER PUBLICATIONS

U.S. Appl. No. 12/861,719, filed Aug. 23, 2010, Wang et al.
U.S. Appl. No. 12/916,349, filed Oct. 29, 2010, Papp.

(Continued)

(56) **References Cited**

Primary Examiner — Aarti B Berdichevsky
(74) *Attorney, Agent, or Firm* — Squire Sanders (US) LLP

U.S. PATENT DOCUMENTS

4,243,050 A	1/1981	Littleford
4,581,025 A	4/1986	Timmermans
4,710,181 A	12/1987	Fuqua
5,158,545 A	10/1992	Trudell et al.
5,211,654 A	5/1993	Kaltenbach
5,250,033 A	10/1993	Evans et al.
5,352,236 A	10/1994	Jung et al.
5,458,615 A	10/1995	Klemm et al.
5,545,211 A	8/1996	An et al.
5,591,226 A	1/1997	Trerotola et al.
5,647,857 A	7/1997	Anderson et al.

(57) **ABSTRACT**

A medical device includes a polymer scaffold crimped to a catheter having an expansion balloon. A sheath pair is placed over the crimped scaffold after crimping to reduce recoil of the crimped polymer scaffold and maintain scaffold-balloon engagement relied on to hold the scaffold to the balloon when the scaffold is being delivered to a target in a body. The sheath pair is removed by a health professional before placing the scaffold within the body.

19 Claims, 6 Drawing Sheets

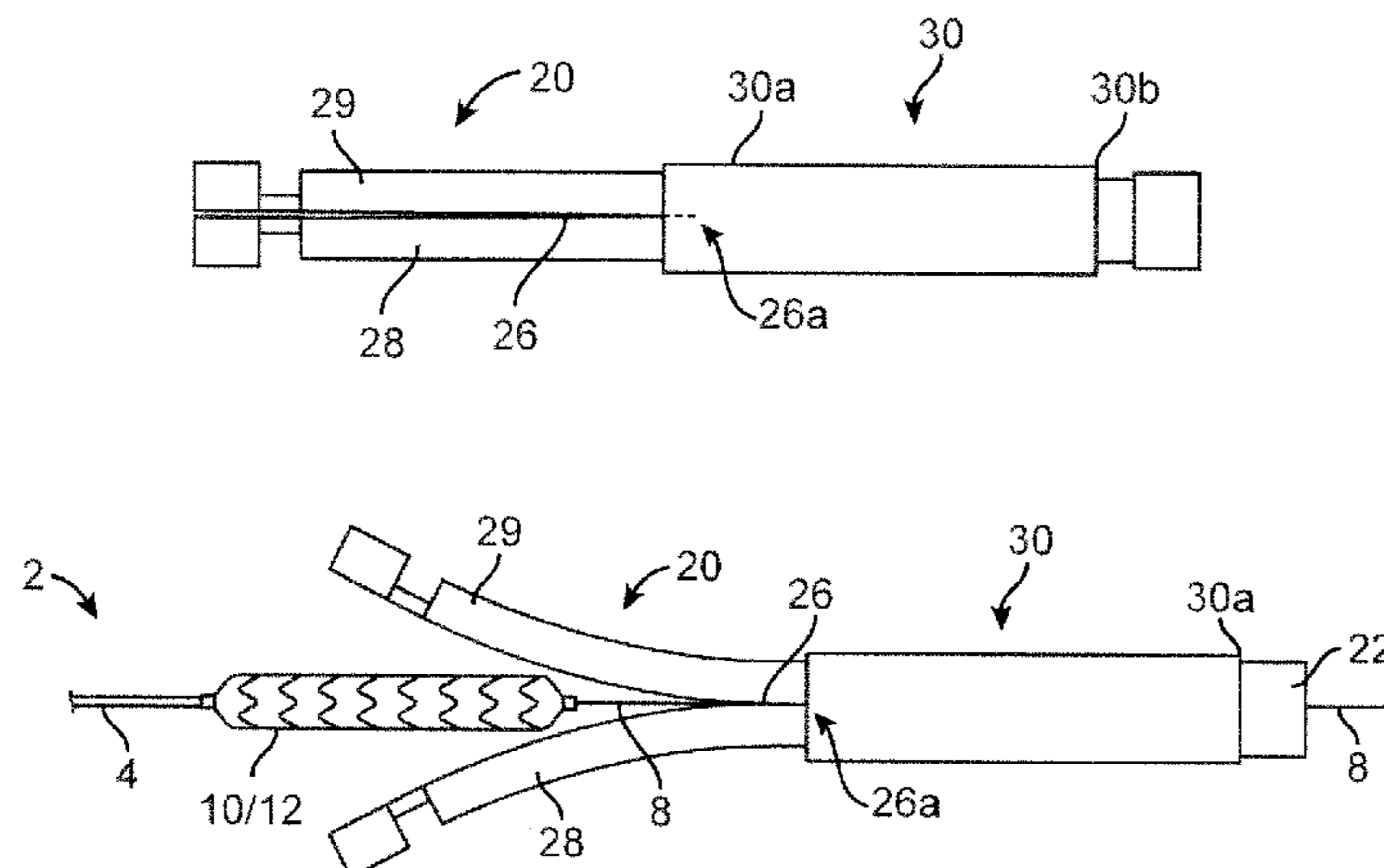

US 8,414,528 B2

Page 2

U.S. PATENT DOCUMENTS

6,254,609 B1 7/2001 Vrba et al.
6,334,867 B1 1/2002 Anson
6,342,066 B1 1/2002 Toro et al.
6,355,013 B1 3/2002 Van Muiden
6,416,529 B1 7/2002 Holman et al.
6,533,806 B1 3/2003 Sullivan et al.
6,749,584 B2* 6/2004 Briggs et al. 604/103.05
6,783,542 B2 8/2004 Eidenschink
6,790,224 B2 9/2004 Gerberding
6,805,703 B2 10/2004 McMorrow
6,827,731 B2 12/2004 Armstrong et al.
6,899,727 B2 5/2005 Armstrong et al.
7,198,636 B2 4/2007 Cully et al.
7,314,481 B2 1/2008 Karpel
7,347,868 B2 3/2008 Burnett et al.
7,384,426 B2 6/2008 Wallace et al.
7,618,398 B2 11/2009 Holman et al.
2001/0001128 A1* 5/2001 Holman et al. 623/1.11
2002/0052640 A1 5/2002 Bigus et al.

2002/0099431 A1* 7/2002 Armstrong et al. 623/1.11
2003/0004561 A1 1/2003 Bigus et al.
2003/0212373 A1 11/2003 Hall et al.
2004/0073286 A1 4/2004 Armstrong et al.
2004/0143315 A1 7/2004 Bruun et al.
2006/0015171 A1 1/2006 Armstrong
2008/0010947 A1 1/2008 Huang et al.
2009/0221965 A1* 9/2009 Osypka 604/160
2010/0004735 A1 1/2010 Yang et al.
2011/0184509 A1* 7/2011 Von Oepen et al. 623/1.23
2012/0042501 A1* 2/2012 Wang et al. 29/505
2012/0109281 A1* 5/2012 Papp 623/1.15

OTHER PUBLICATIONS

U.S. Appl. No. 13/089,225, filed Apr. 18, 2011, Roberts et al.
U.S. Appl. No. 13/107,666, filed May 13, 2011, Wang.
International Search Report for PCT/US2012/039719, mailed Aug.
29, 2012, 13 pgs.

* cited by examiner

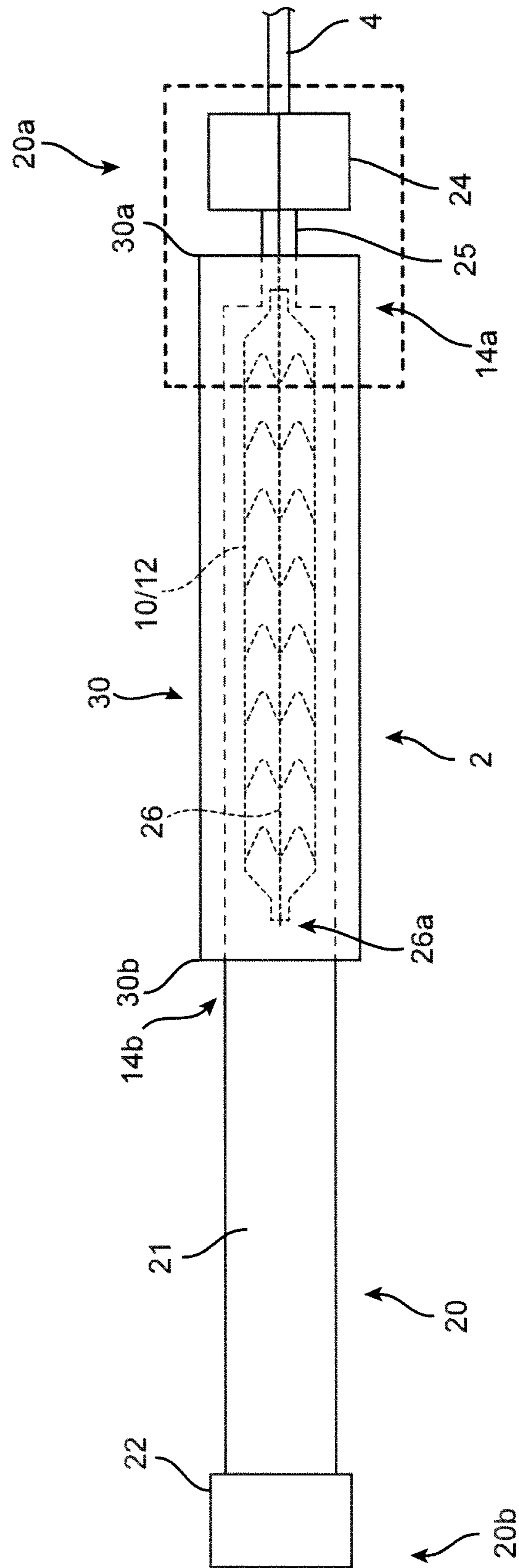

FIG. 1

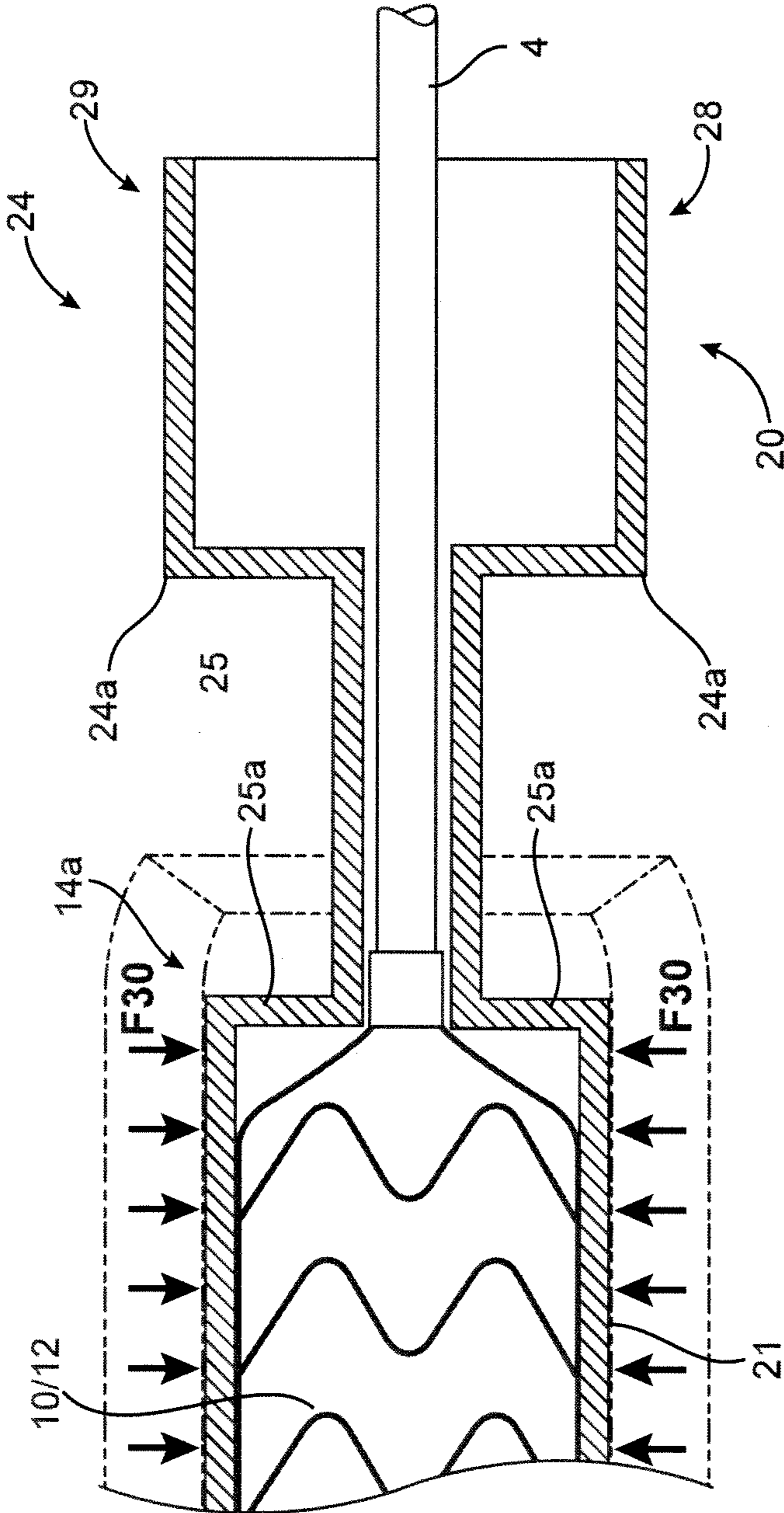

FIG. 1A

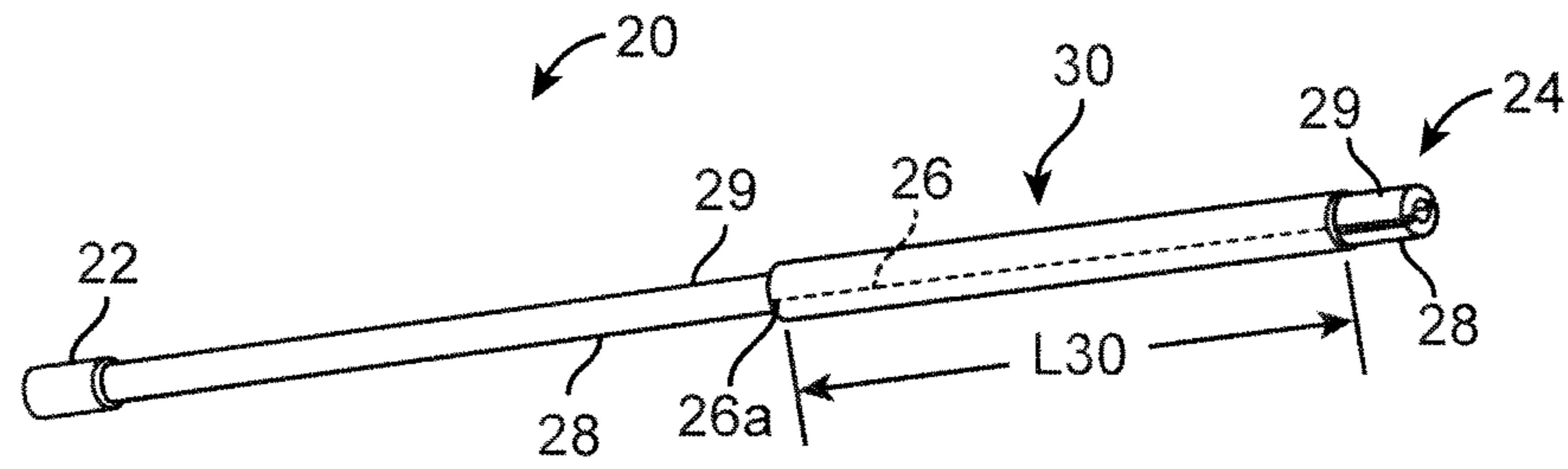

FIG. 2A

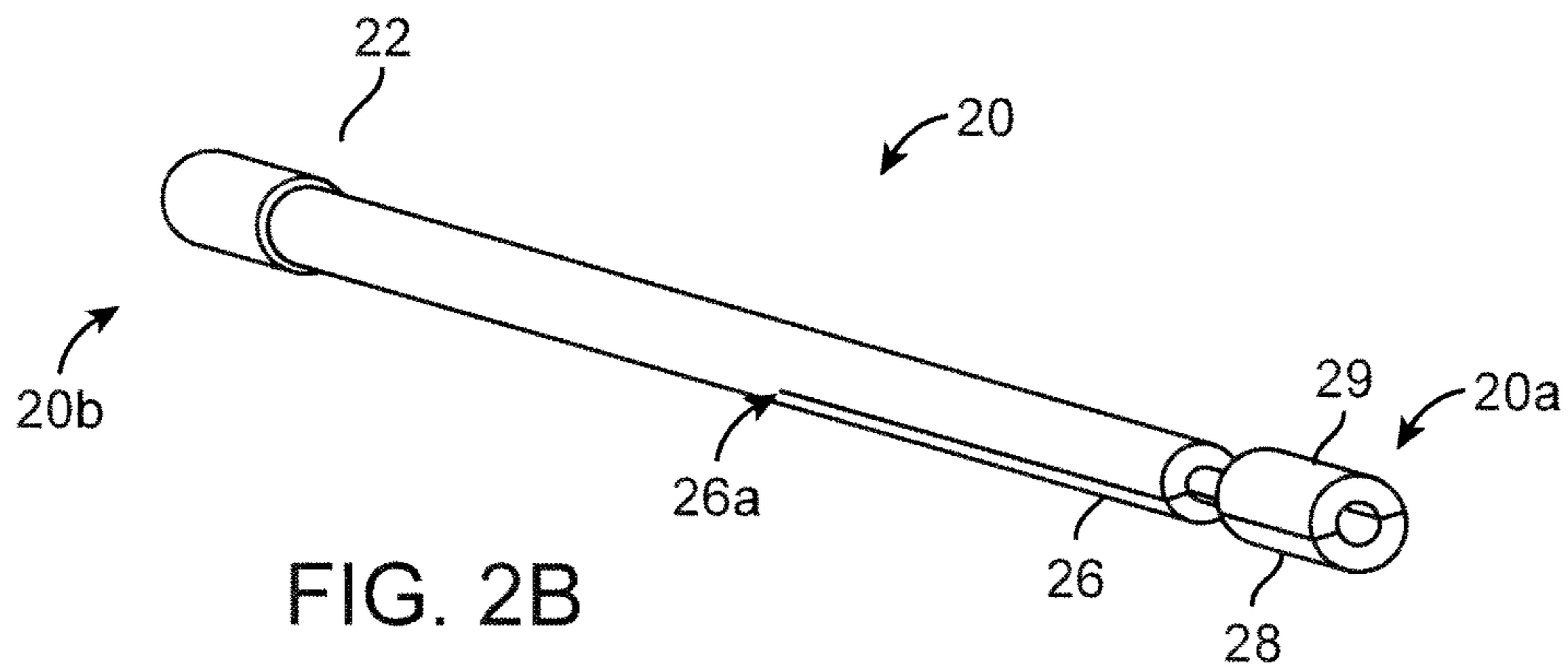

FIG. 2B

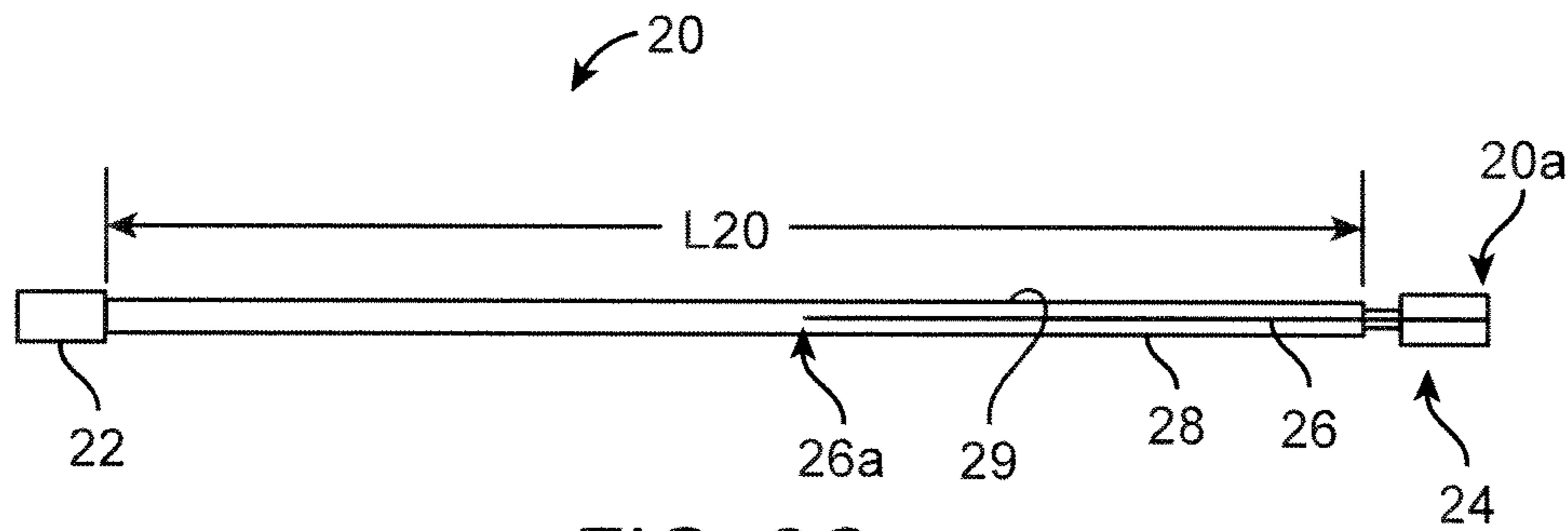

FIG. 2C

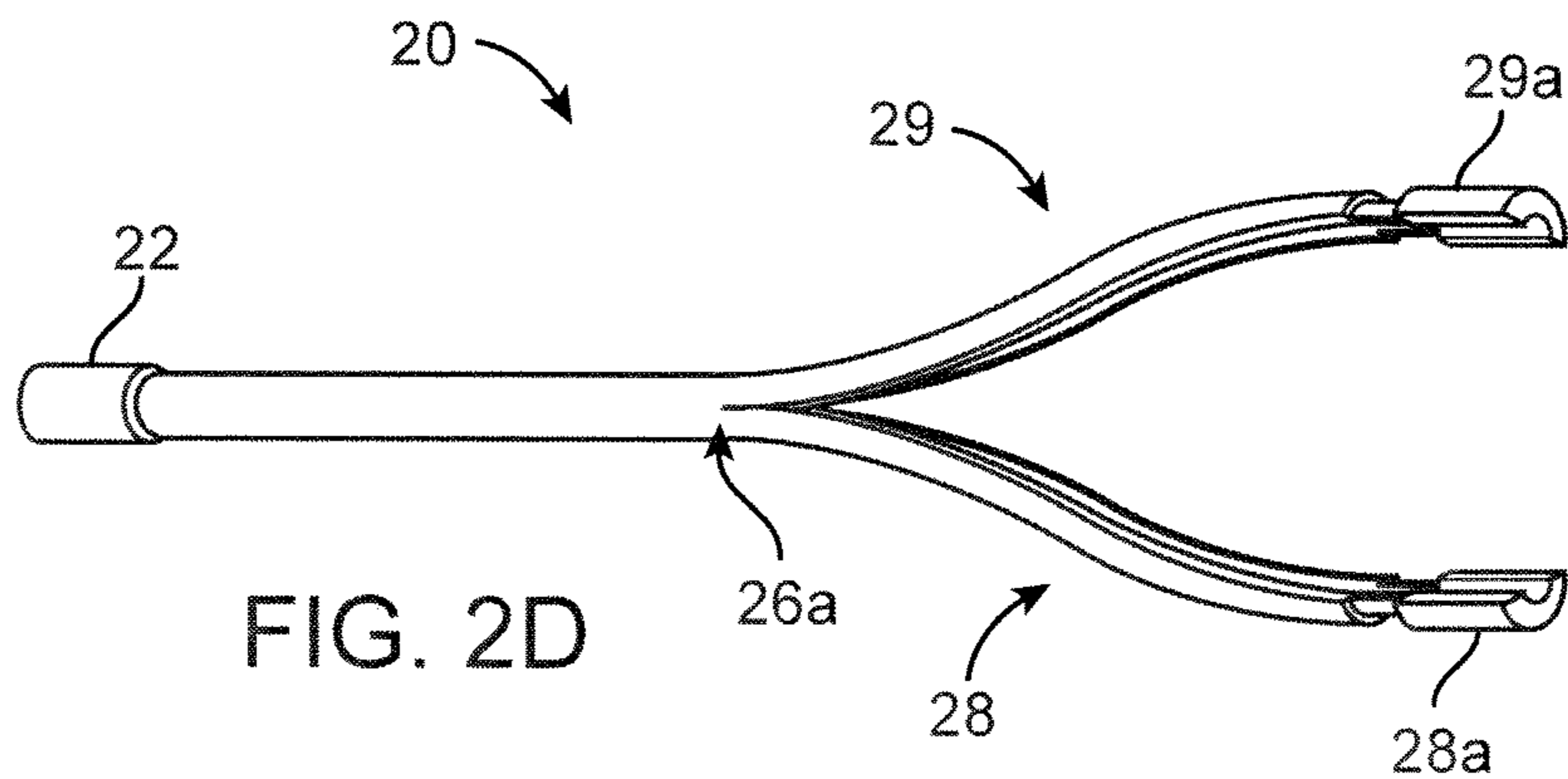

FIG. 2D

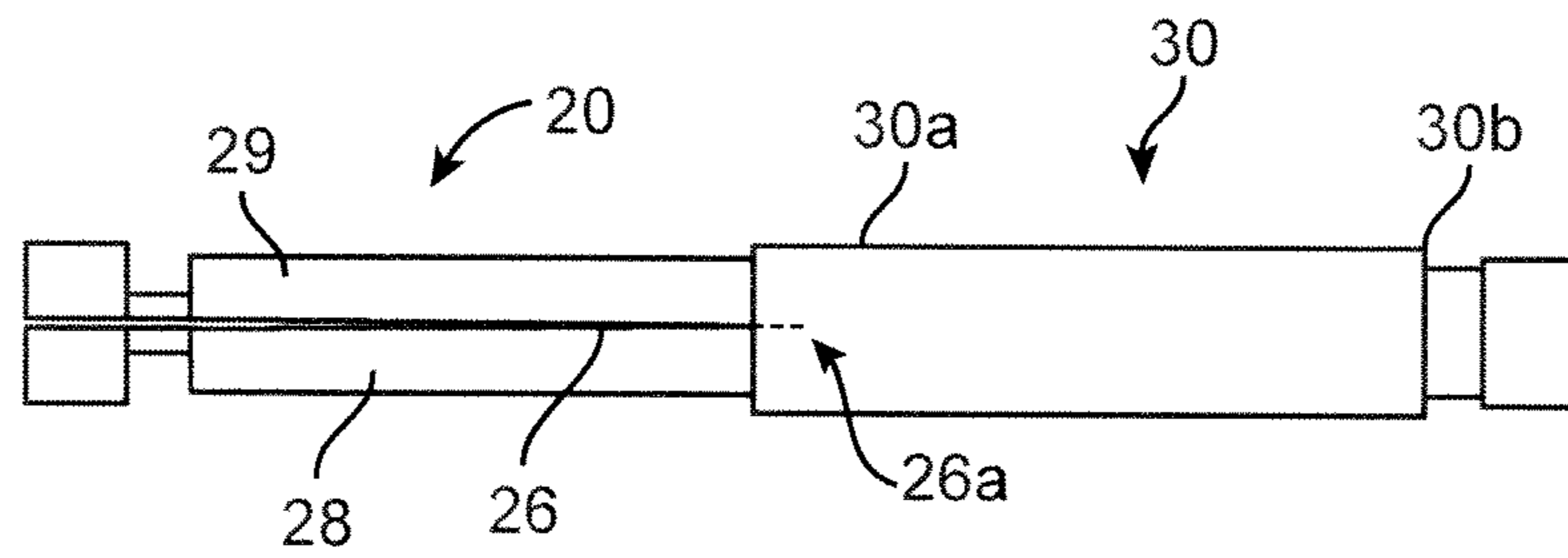

FIG. 3A

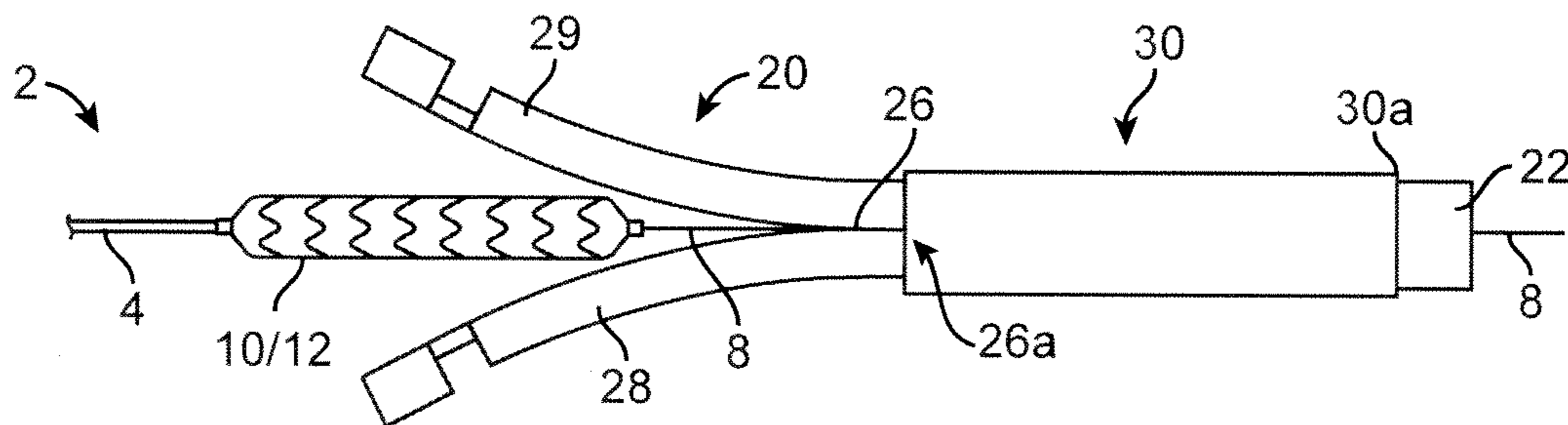

FIG. 3B

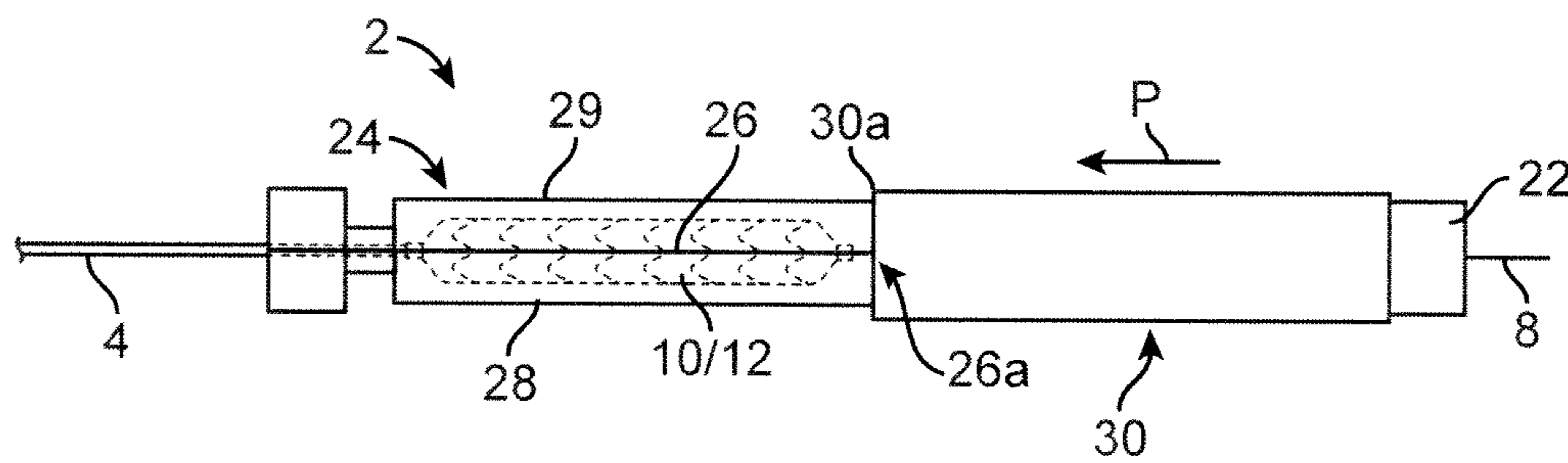

FIG. 3C

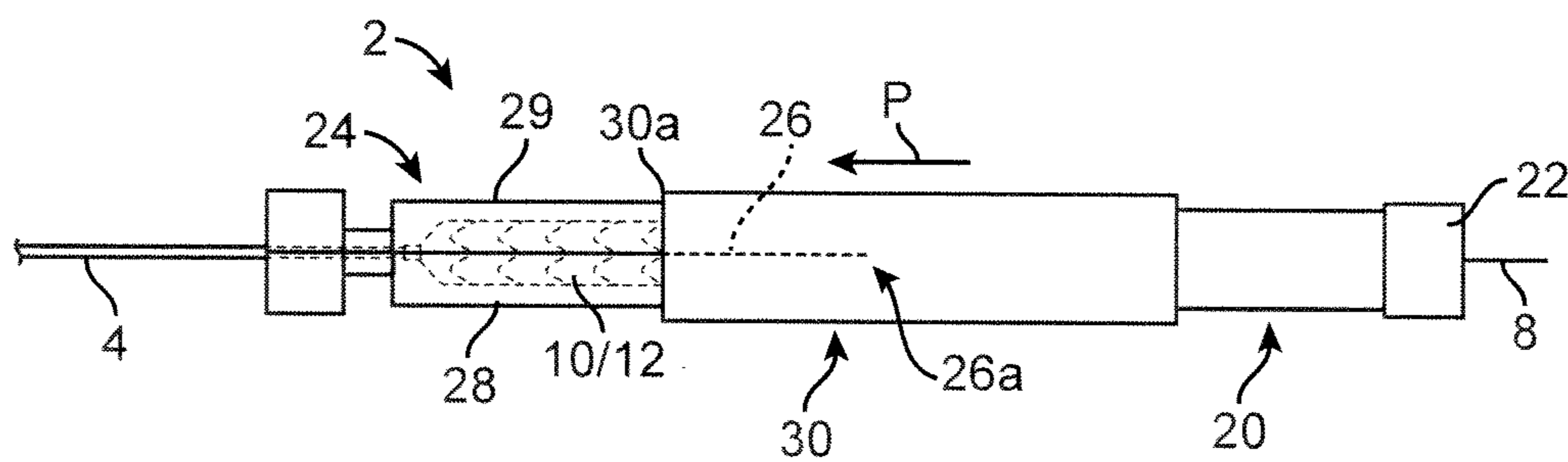

FIG. 3D

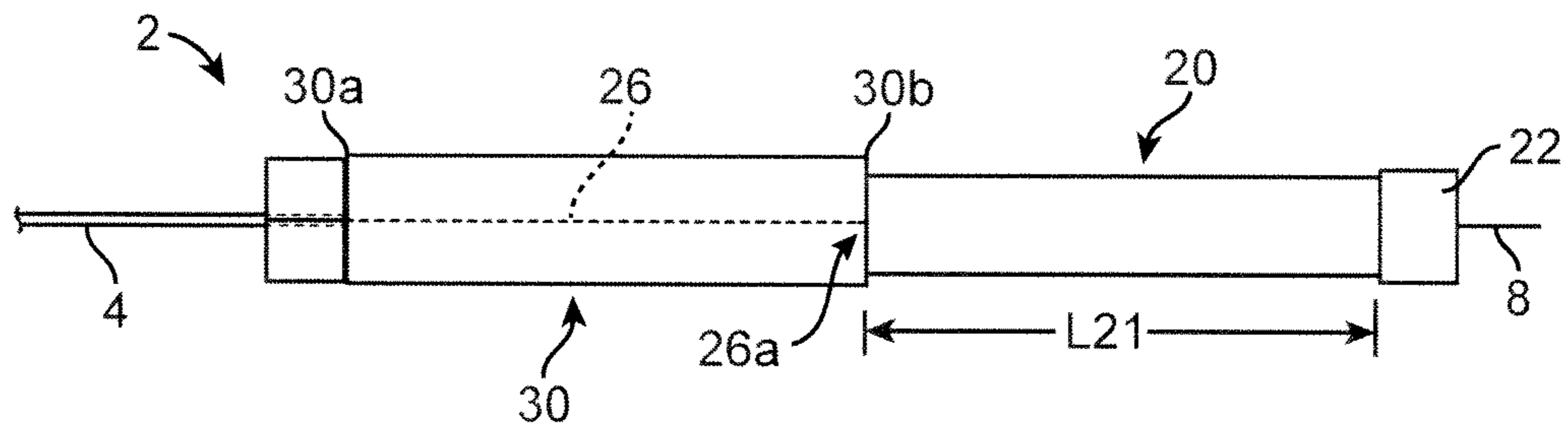

FIG. 4A

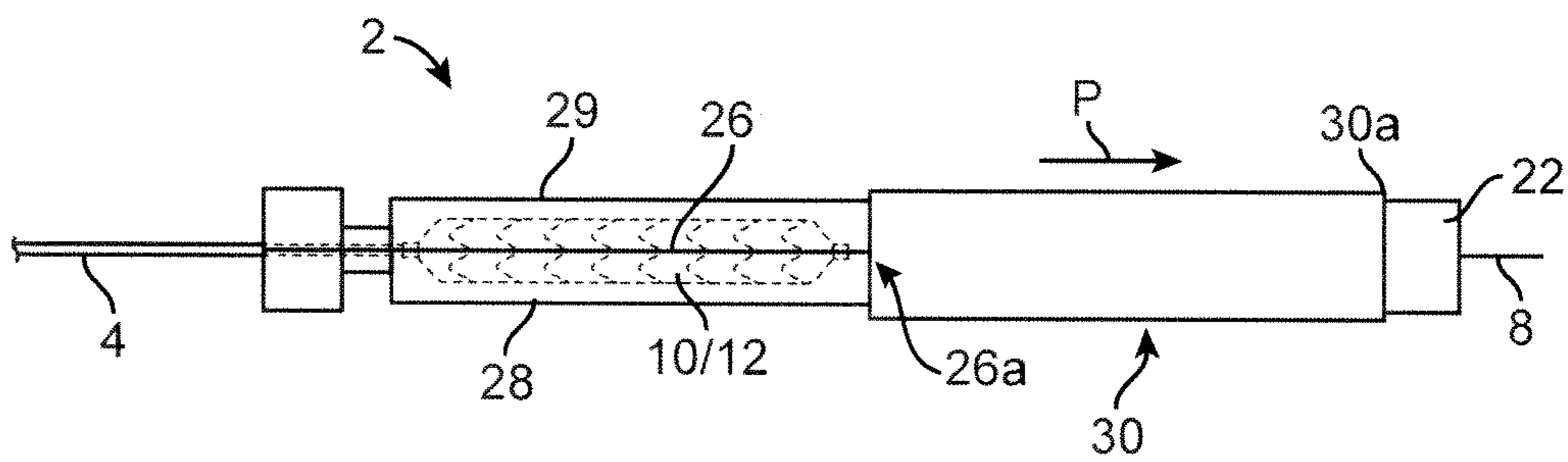

FIG. 4B

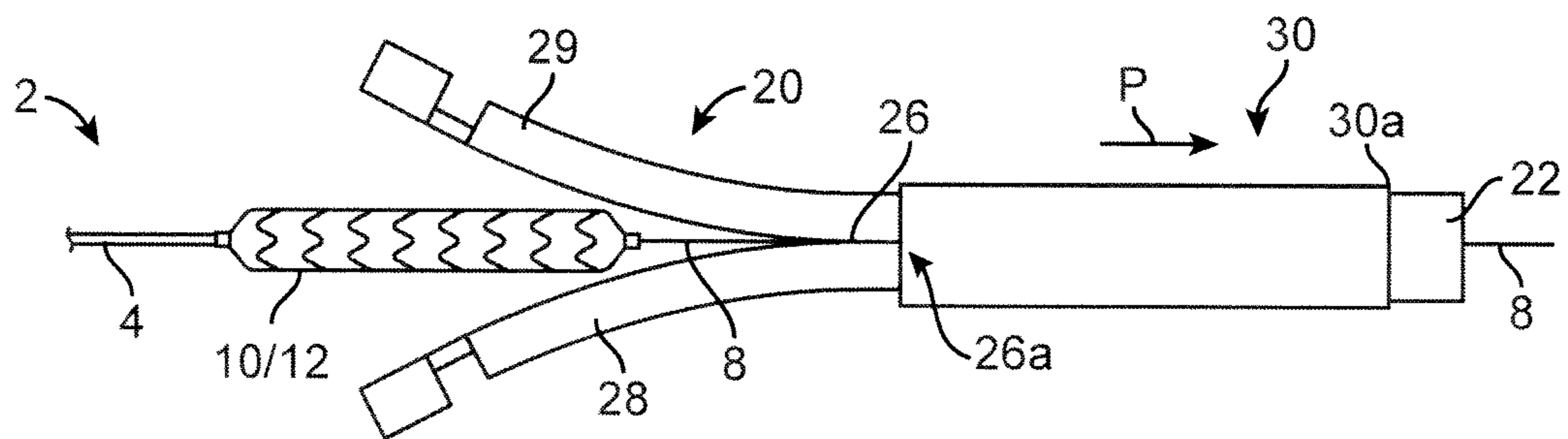

FIG. 4C

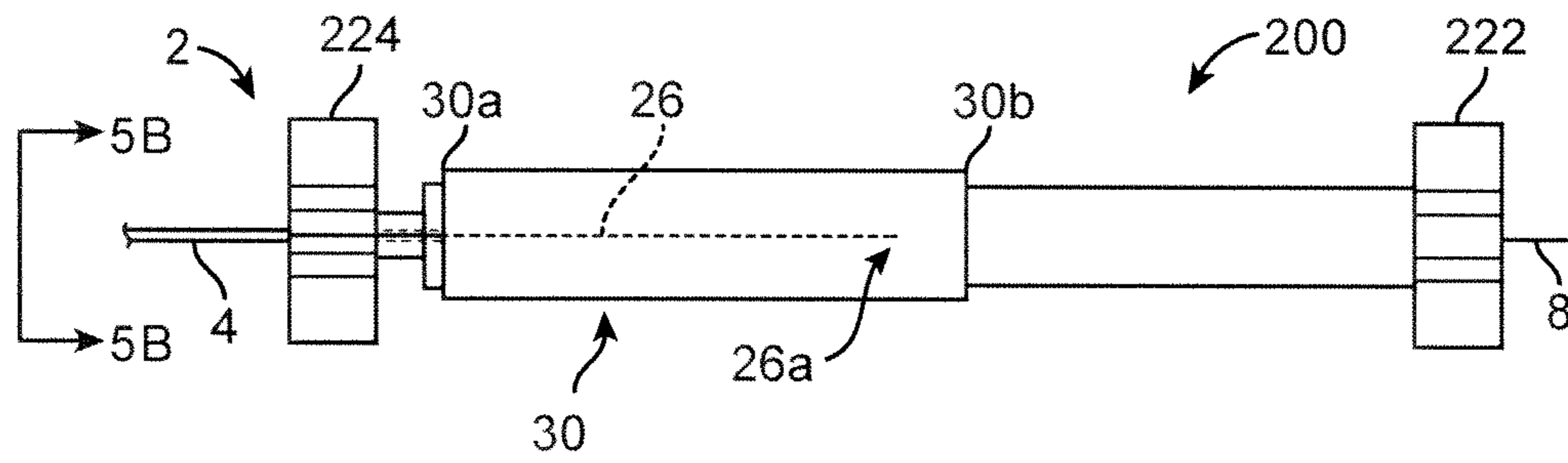

FIG. 5A

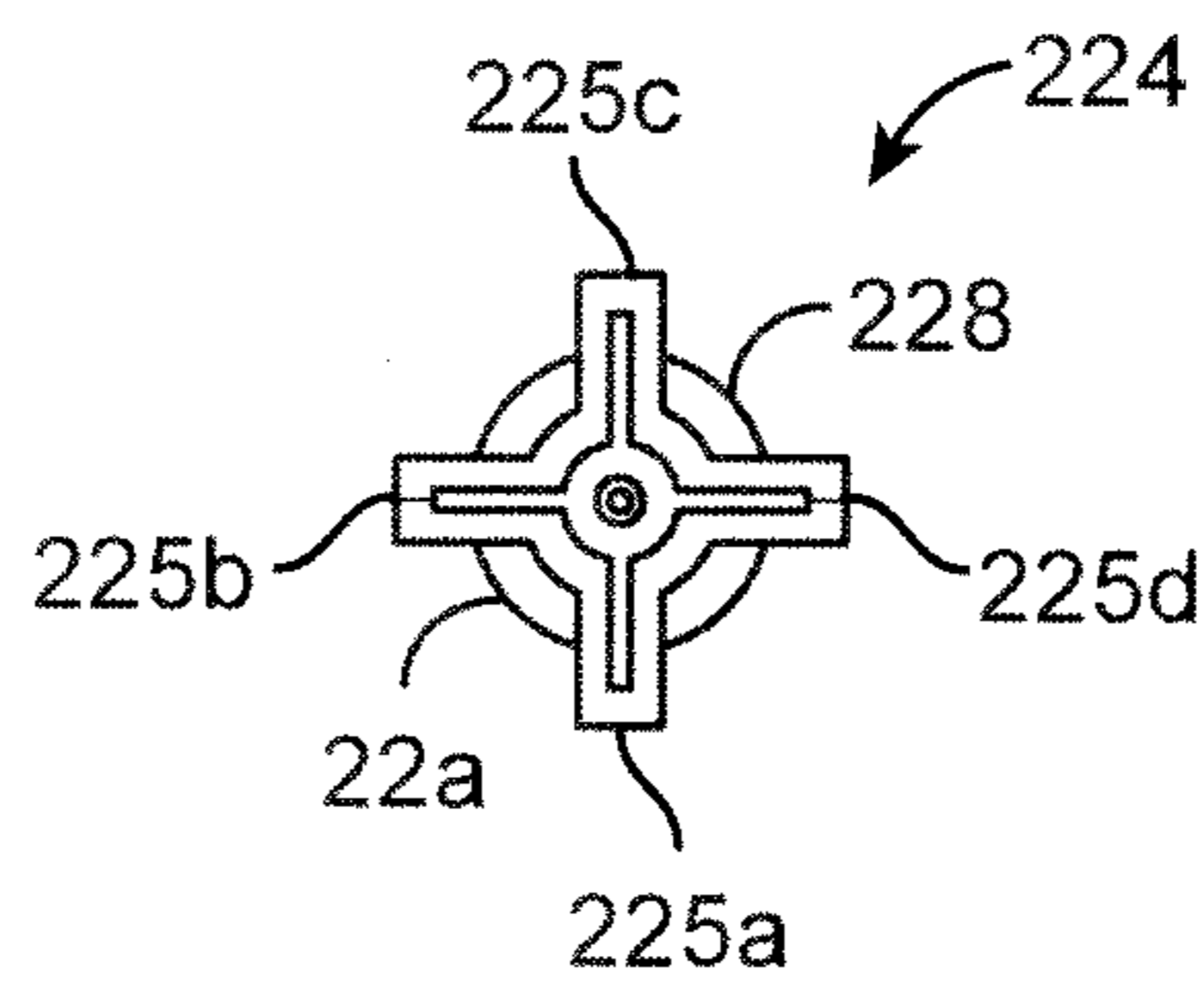

FIG. 5B

POLYMER SCAFFOLD SHEATHS

BACKGROUND OF THE INVENTION

1. Field of the Invention

The present invention relates to drug-eluting medical devices; more particularly, the invention relates to sheaths for polymeric scaffolds crimped to a delivery balloon.

2. Background of the Invention

A variety of non-surgical interventional procedures have been developed over the years for opening stenosed or occluded blood vessels in a patient caused by the build up of plaque or other substances on the walls of the blood vessel. Such procedures usually involve the percutaneous introduction of an interventional device into the lumen of the artery. In one procedure the stenosis can be treated by placing an expandable interventional device such as an expandable stent into the stenosed region to hold open and sometimes expand the segment of blood vessel or other arterial lumen. Metal or metal alloy stents have been found useful in the treatment or repair of blood vessels after a stenosis has been compressed by percutaneous transluminal coronary angioplasty (PTCA), percutaneous transluminal angioplasty (PTA) or removal by other means. Metal stents are typically delivered in a compressed condition to the target site, then deployed at the target into an expanded condition or deployed state to support the vessel.

The following terminology is used. When reference is made to a “stent”, this term will refer to a metal or metal alloy structure, generally speaking, while a scaffold will refer to a polymer structure. It is understood, however, that the art sometimes uses the term “stent” when referring to either a metal or polymer structure.

Metal stents have traditionally fallen into two general categories—balloon expanded and self-expanding. The later type expands to a deployed or expanded state within a vessel when a radial restraint is removed, while the former relies on an externally-applied force to configure it from a crimped or stowed state to the deployed or expanded state.

For example, self-expanding stents formed from, for example, shape memory metals or super-elastic nickel-titanium (NiTi) alloys are designed to automatically expand from a compressed state when the stent is advanced out of a distal end of the delivery catheter into the body lumen, i.e. when the radial restraint is withdrawn or removed. Typically, these stents are delivered within a radially restraining polymer sheath. The sheath maintains the low profile needed to navigate the stent towards the target site. Once at the target site, the sheath is then removed or withdrawn in a controlled manner to facilitate deployment or placement at the desired examples. Examples of self-expanding stents constrained within a sheath when delivered to a target site within a body are found in U.S. Pat. No. 6,254,609, US 20030004561 and US 20020052640.

Balloon expanded stents, as the name implies, are expanded upon application of an external force through inflation of a balloon, upon which the stent is crimped. The expanding balloon applies a radial outward force on the luminal surfaces of the stent. During the expansion from a crimped or stowed, to deployed or expanded state the stent undergoes a plastic or irreversible deformation in the sense that the stent will essentially maintain its deformed, deployed state after balloon pressure is withdrawn.

Balloon expanded stents may also be disposed within a sheath, either during a transluminal delivery to a target site or during the assembly of the stent-balloon catheter delivery system. The balloon expanded stent may be contained within

a sheath when delivered to a target site to minimize dislodgment of the stent from the balloon while en route to the target vessel. Sheaths may also be used to protect a drug eluting stent during a crimping process, which presses or crimps the stent to the balloon catheter. When an iris-type crimping mechanism, for example, is used to crimp a stent to balloon, the blades of the crimper, often hardened metal, can form gouges in a drug-polymer coating or even strip off coating such as when the blades and/or stent struts are misaligned during the diameter reduction. Examples of stents that utilize a sheath to protect the stent during a crimping process are found in U.S. Pat. No. 6,783,542 and U.S. Pat. No. 6,805,703.

A polymer scaffold, such as that described in US 20100004735 may be made from a biodegradable, bioabsorbable, bioresorbable, or bioerodable polymer. The terms biodegradable, bioabsorbable, bioresorbable, biosoluble or bioerodable refer to the property of a material or stent to degrade, absorb, resorb, or erode away after the scaffold has been implanted at the target vessel. The polymer scaffold described in US 2010/0004735, as opposed to a metal stent, is intended to remain in the body for only a limited period of time. In many treatment applications, the presence of a stent in a body may be necessary for a limited period of time until its intended function of, for example, maintaining vascular patency and/or drug delivery is accomplished. Moreover, it is believed that biodegradable scaffolds, as opposed to a metal stent, allow for improved healing of the anatomical lumen and reduced incidence of late stent thrombosis. In these cases, there is a desire to treat a vessel using a polymer scaffold, in particular a bioerodable polymer scaffold, as opposed to a metal stent, so that the prosthesis’s presence in the vessel is for a limited duration. However, there are numerous challenges to overcome when developing a delivery system having a polymer scaffold.

Polymer material considered for use as a polymeric scaffold, e.g. poly(L-lactide) (“PLLA”), poly(L-lactide-co-glycolide) (“PLGA”), poly(D-lactide-co-glycolide) or poly(L-lactide-co-D-lactide) (“PLLA-co-PDLA”) with less than 10% D-lactide, and PLLD/PDLA stereo complex, may be described, through comparison with a metallic material used to form a stent, in some of the following ways. A suitable polymer has a low strength to weight ratio, which means more material is needed to provide an equivalent mechanical property to that of a metal. Therefore, struts must be made thicker and wider to have the required strength for a stent to support lumen walls at a desired radius. The scaffold made from such polymers also tends to be brittle or have limited fracture toughness. The anisotropic and rate-dependant inelastic properties (i.e., strength/stiffness of the material varies depending upon the rate at which the material is deformed) inherent in the material only compound this complexity in working with a polymer, particularly, bio-absorbable polymer such as PLLA or PLGA. Challenges faced when securing a polymer scaffold to a delivery balloon are discussed in U.S. patent application Ser. No. 12/861,719.

When using a polymer scaffold, several of the accepted processes for metal stent handling can no longer be used. A metal stent may be crimped to a balloon in such a manner as to minimize, if not eliminate recoil in the metal structure after removal from the crimp head. Metal materials used for stents are generally capable of being worked more during the crimping process than polymer materials. This desirable property of the metal allows for less concern over the metal stent—balloon engagement changing over time when the stent-catheter is packaged and awaiting use in a medical procedure. Due to the material’s ability to be worked during the crimping process, e.g., successively crimped and released at high tem-

peratures within the crimp mechanism, any propensity for elastic recoil in the material following crimping can be significantly reduced, if not eliminated, without affecting the stent's radial strength when later expanded by the balloon. As such, following a crimping process the stent-catheter assembly often does not need packaging or treatment to maintain the desired stent-balloon engagement and delivery profile. If the stent were to recoil to a larger diameter, meaning elastically expand to a larger diameter after the crimping forces are withdrawn, then significant dislodgment force could be lost and the stent-balloon profile not maintained at the desired diameter needed to deliver the stent to the target site.

While a polymer scaffold may be formed so that it is capable of being crimped in such a manner as to reduce inherent elastic recoil tendencies in the material when crimped, e.g., by maintaining crimping blades on the scaffold surface for an appreciable dwell period, the effectiveness of these methods are limited. Significantly, the material generally is incapable of being worked to the degree that a metal stent may be worked without introducing deployed strength problems, such as excessive cracking in the material. Recoil of the crimped structure, therefore, is a problem that needs to be addressed.

In view of the foregoing, there is a need to address the challenges associated with securing a polymer scaffold to a delivery balloon and maintaining the integrity of a scaffold-balloon catheter delivery system up until the time when the scaffold and balloon are delivered to a target site within a body.

SUMMARY OF THE INVENTION

The invention is directed to sheaths used to maintain a polymer scaffold balloon engagement and delivery system profile and methods for assembly of a medical device including a balloon expandable polymer scaffold contained within a sheath. The invention is also directed to a sheath and methods for applying a sheath that enable the sheath to be easily removed by a medical professional, e.g., a doctor, in an intuitive manner without disrupting the crimped scaffold-balloon engagement or damaging the scaffold. Sheaths according to the invention are removed before the medical device is introduced into a patient.

Sheaths according to the invention are particularly useful for maintaining scaffold-balloon engagement and desired delivery profile following a crimping process for scaffolds formed at diameters near to, or larger than a deployed diameter are crimped down to a crossing-profile, or crimped diameter. A scaffold formed at these diameters can exhibit enhanced radial strength when supporting a vessel, as compared to a scaffold formed nearer to a crimped diameter. A scaffold formed near to a deployed diameter, however, increases the propensity for elastic recoil in the scaffold following the crimping process, due to the shape memory in the material. The shape memory relied on for enhancing radial strength at deployment, therefore, also introduces greater elastic recoil tendencies for the crimped scaffold. Recoil both increases the crossing profile and reduces the scaffold-balloon engagement needed to hold the scaffold on the balloon. In one aspect, the invention is directed to maintaining the crossing profile and/or maintaining balloon-scaffold engagement for scaffolds formed near to a deployed diameter.

In another aspect, the invention is directed to a method of assembly of a catheter that includes crimping a polymer scaffold to a balloon of the catheter and within a short period of removal of the scaffold from the crimper placing a restraining sheath over the scaffold. The steps may further include apply-

ing an extended dwell time following a final crimping of the scaffold, followed by applying the restraining sheath. Both the crimping dwell time and applied restraining sheath are intended to reduce recoil in the crimped scaffold. The restraining sheath may include both a protecting sheath and a constraining sheath.

In another aspect, the invention is directed to a sterilized medical device, e.g., by E-beam radiation, contained within a sterile package, the package containing a scaffold crimped to a balloon catheter and a sheath disposed over the crimped scaffold to minimize recoil of the crimped scaffold. The sheath covers the crimped scaffold and extends beyond a distal end of the catheter. The sheath may extend at least the length of the scaffold beyond the distal end of the catheter. At the distal end of the sheath there is an portion configured for being manually grabbed and pulled distally of the catheter to remove the sheath from the catheter.

In another aspect, the invention is directed to an apparatus and methods for removing a sheath pair from a scaffold in a safe, intuitive manner by a health professional. According to this aspect of the invention, the sheath pair may be removed by a medical specialist such as a doctor without risk of the scaffold becoming dislodged from the balloon or damaged, such as when the sheath pair is accidentally removed in an improper manner by a health professional.

Sheaths arranged according to the invention provide an effective radial constraint for preventing recoil in a crimped scaffold, yet are comparatively easy to manually remove from the scaffold. A sheath that applies a radial constraint can be difficult to remove manually without damaging the crimped scaffold, dislodging or shifting it on the balloon. In these cases it is desirable to arrange the sheaths in a manner to apply an effective radial constraint yet make the sheaths capable of manual removal in a safe and intuitive manner. By making the sheath removal process easy to follow and intuitive, the possibility that a health professional will damage the medical device when removing the sheath is reduced.

According to another aspect of the invention a crimped scaffold is constrained within a protecting sheath and a constraining sheath. The protecting sheath protects the integrity of the crimped scaffold-balloon structure while the constraining sheath is applied and/or removed from the crimped scaffold. Arranged in this manner a radial inward force may be applied to a crimped scaffold via a sheath, without risking dislodgement or shifting of the scaffold on the balloon when the sheath is manually removed.

According to another aspect, a sheath pair is used to impose a higher radial inward constraint on a crimped polymer scaffold than is possible using a single sheath that must be manually removed from the scaffold before the scaffold can be introduced into a patient.

According to another aspect of the invention, a sheath pair covering a crimped scaffold is removed by sliding a first sheath over a second sheath until the first sheath abuts an end of the second sheath, at which point the second sheath is removed by simultaneously pulling on both sheaths.

In accordance with the foregoing objectives, in one aspect of the invention there is a method for assembling a scaffold-balloon catheter, comprising providing a balloon-catheter having a scaffold crimped to the balloon; and constraining the crimped scaffold including placing a protecting sheath over the scaffold to protect the scaffold, then pushing a constraining sheath over the protecting sheath to constrain recoil in the scaffold using the constraining sheath; wherein the scaffold is configured for being passed through the body of a patient only after the constraining sheath and protecting sheath are removed.

5

In another aspect, there is an apparatus, comprising a catheter assembly having a distal end and including a scaffold comprising a polymer crimped to a balloon; a sheath disposed over the scaffold, the sheath applying a radial inward force on the crimped scaffold to limit recoil of the scaffold; the sheath extending distally of the catheter distal end by about a length equal to the length of the scaffold; and wherein the apparatus is configured for being passed through the body of a patient only after the sheath is removed. The sheath may comprise a protecting sheath and a constraining sheath that is placed over the protecting sheath and the crimped scaffold to limit recoil of the scaffold by an applying an inwardly directed radial force on the crimped scaffold.

In another aspect, there is an apparatus, comprising a scaffold crimped to a balloon of a catheter, the catheter having a distal end and the scaffold being crimped to the balloon proximally of the distal end; a first sheath disposed over the scaffold, the first sheath including an extension that is distal of the catheter distal end; and a second sheath disposed over the scaffold; wherein the first sheath and second sheath are configured such that the apparatus is capable of being configured into a medical device suitable for being introduced into a patient by (a) pulling the second sheath distally along the first sheath outer surface such that the second sheath is displaced to a location substantially distal of the scaffold or the catheter distal end, and (b) after the first sheath has been moved to the substantially distal location, removing the first sheath from the scaffold by pulling the second sheath against the first sheath extension, thereby displacing the first sheath distally with the second sheath.

In another aspect, there is an apparatus, comprising a scaffold crimped to a balloon of a catheter, the catheter having a distal end and the scaffold being crimped to the balloon proximally of the distal end; a first sheath disposed over the scaffold, the first sheath including an extension distal of the catheter distal end and a portion forming an interfering ledge disposed proximal to the scaffold; and a second sheath disposed over the scaffold and first sheath, the second sheath applying a preload to the scaffold and the first sheath to maintain contact between the first sheath and scaffold; wherein the first sheath is removable from the scaffold only after the second sheath has been moved to the distal extension such that the interfering ledge is capable of deflecting away from the scaffold only when the second sheath is removed from the scaffold; and wherein the apparatus is configured as a medical device suitable for being introduced into a patient when the first and second sheaths are removed from the catheter.

INCORPORATION BY REFERENCE

All publications and patent applications mentioned in the present specification are herein incorporated by reference to the same extent as if each individual publication or patent application was specifically and individually indicated to be incorporated by reference. To the extent there are any inconsistent usages of words and/or phrases between an incorporated publication or patent and the present specification, these words and/or phrases will have a meaning that is consistent with the manner in which they are used in the present specification.

BRIEF DESCRIPTION OF THE DRAWINGS

FIG. 1 is a side view of a polymer scaffold-balloon catheter assembly (medical device) with a pair of sheaths placed over the crimped scaffold.

6

FIG. 1A shows a side view cross-section of a portion of the device of FIG. 1 at a proximal end thereof.

FIG. 2A is a perspective view of the sheath pair of FIG. 1.

FIGS. 2B-2D show a side view, and first and perspective views of a protecting sheath of the sheath pair of FIG. 2A.

FIGS. 3A-3D illustrate a method of securing the sheath pair of FIG. 2A to a distal end of the catheter assembly of FIG. 1.

FIGS. 4A-4C illustrate a method of removing the sheath pair of FIG. 2A from the distal end of the catheter assembly of FIG. 1.

FIGS. 5A-5B illustrate side and front views of an alternative embodiment of a protecting sheath.

DETAILED DESCRIPTION OF EMBODIMENTS

A polymer scaffold according to a preferred embodiment is formed from a radially expanded, or biaxially expanded extruded PLLA tube. The scaffold is laser cut from the expanded tube. The diameter of the tube is preferably selected to be about the same, or larger than the intended deployed diameter for the scaffold to provided desirable radial strength characteristics, as explained earlier. The scaffold is then crimped onto the balloon of the balloon catheter. Preferably, an iris-type crimper is used to crimp the scaffold to the balloon. The desired crimped profile for the scaffold is $\frac{1}{2}$ or less than $\frac{1}{2}$ of the starting (pre crimp) diameter of the expanded tube and scaffold. In the embodiments the ratio of the starting diameter (before crimping) to the final crimp diameter may be 2:1, 2.5:1, 3:1, or higher. For example, the ratio of starting diameter to final crimped diameter may be greater than the ratio of the deployed diameter to the final crimped diameter of the scaffold, e.g., from about 4:1 to 6:1.

The pre-crimp memory in the scaffold material following crimping will induce some recoil when the scaffold is removed from the crimper. While a dwell period within the crimper can reduce this recoil tendency, it is found that there is residual recoil that needs to be restrained while the scaffold is awaiting use. This is done by placing a restraining sheath over the scaffold immediately after the crimper blades are released and the scaffold removed from the crimper head. This need to reduce recoil is particularly evident when the diameter reduction during crimping is high, since for a larger starting diameter compared to the crimped diameter the crimped material can have higher recoil tendencies. Examples of polymers that may be used to construct sheaths described herein are Pebax, PTFE, Polyethelene, Polycarbonate, Polyimide and Nylon. Examples of restraining sheaths for polymer scaffold, and methods for attaching and removing restraining sheaths for polymer scaffold are described in U.S. application Ser. No. 12/916,349.

FIG. 1 shows a side view of a distal portion of a scaffold-balloon catheter assembly 2. The catheter assembly 2 includes a catheter shaft 4 and a scaffold 10 crimped to a delivery balloon 12. As shown there are two separate sheaths 20, 30 disposed over the scaffold 10. The scaffold 10 is contained within a protecting sheath 20 and a constraining sheath 30, which is slid over the outer surface of the protecting sheath 20 to position it over the scaffold 10. Before inserting the catheter assembly 2 distal end within a patient, both the constraining sheath 30 and protecting sheath 20 are removed by a health professional.

The sheaths 20, 30 provide an effective radial constraint for reducing recoil in the crimped scaffold 10. Yet the sheaths 20, 30 are also easily removed by a health professional at the time of a medical procedure. A sheath that applies a radial constraint can be difficult to manually remove without adversely

affecting the structural integrity of the medical device. In these cases, it is desirable to arrange the sheaths so that special handling is not required by the health professional when the sheath is manually removed. By making the sheath removal process easy to follow or intuitive, the possibility that a health professional will damage the medical device by improperly removing the sheath is reduced.

The constraint imposed by the sheaths **20**, **30** maintain the scaffold **10** at essentially the same, or close to the same diameter it had when removed from the crimping mechanism, i.e., the crimped crossing profile, which is needed for traversing tortuous vessels to deliver the scaffold **10** to a target location in a body. The sheath **30** is tightly fit over the sheath **20** and scaffold **10** so that the radial inward force applied on the scaffold **10** can reduce recoil in the scaffold **10**. The health professional may then remove both sheaths at the time of the medical procedure. As such, any potential recoil in the scaffold **10** prior to using the medical device is minimized.

The sheath **30**, although imposing a tight fit on the scaffold **10** (through sheath **30**), can be easily removed by a health professional without risk of the scaffold **10** being accidentally pulled off of the balloon **12**. This is accomplished by the manner in which the sheath **20** is positioned and removed from the scaffold **10**. If there are excessive pulling forces on the scaffold **10** when sheaths are removed, the scaffold **10** may dislodge from a balloon **12**, or shift on the balloon **12**, thereby reducing scaffold-balloon engagement relied on to hold the scaffold **10** to the balloon **12**.

When the scaffold **10** is constrained by sheath **30**, as in FIG. 1, the constraining sheath **30** is located over the section of the protecting sheath **20** where the crimped scaffold **10** is found. This sheath **30** is made from a polymer tube material having a thickness and pre-stressed inner diameter size suitably chosen to cause the sheath **30** to apply a radially inward directed force on the scaffold **10**. The thicker the tube and the smaller the pre-stressed inner diameter size for the sheath **30** the higher this constraint will be on the scaffold **10**. However, the sheath **30** thickness should not be too thick, nor its inner diameter too small as this will make it difficult to slide the sheath **30** over, or remove the sheath **30** from the scaffold **10**. If excessive force is needed to reposition the sheath **30**, the scaffold **10** can dislodge from the balloon **12** or become damaged when the sheath **30** is moved.

If only the single sheath **30** were used to constrain the scaffold **10**, i.e., the sheath **20** is not present, the amount of preload that the sheath **30** could apply to the scaffold **10** without affecting scaffold-balloon engagement would be limited. However, by introducing the protecting sheath **20** between the scaffold-balloon surface and sheath **30** the sheath **30** can impose a higher preload on the scaffold **10** without risk to the integrity of the scaffold-balloon engagement when the sheath **30** is applied to and/or removed from the scaffold **10**. The protecting sheath **20** therefore serves to protect the integrity of the scaffold-balloon structure as the sheath **30** is repositioned relative to the scaffold **10**.

The protecting sheath **20** extends over the entire length of the scaffold (as shown) and beyond the distal tip **6** of the catheter, for reasons that will become apparent. The protecting sheath **20** is preferably formed from a unitary piece of polymer material, which is shaped to form differently sized portions **22**, **24** and **25** for protecting the scaffold/balloon **10/12**.

At the distal end **20b** of sheath **20** there is a raised end **22** in the form of a cylinder section having a larger diameter than the body portion **21** of the sheath **20** to the right of end **22** which covers the scaffold **10** in FIG. 1. As such, raised end **22** provides an abutting surface with respect to distal movement

of sheath **30**, i.e., end **30b** of sheath **30** abuts end **22** when sheath **30** is moved to the left in FIG. 1. End **22** may alternatively take the shape of a cone with the largest diameter end of the cone being the most distal end of the sheath **20**. The raised end **22** is used to remove the sheaths **20**, **30**, as explained below.

The protecting sheath **20** has a cut **26**, extending from the proximal end **20a** to a location about at the distal the tip **6** of the catheter assembly **2**. The cut **26** forms an upper and lower separable half **28**, **29** of the sheath **20**. These halves **29**, **28** are configured to freely move apart when the sheath **30** is positioned towards the distal end **20b**. The location **26a** may be thought of as a living hinge **26a** about which the upper half **29** and lower half **28** of the sheath **20** can rotate, or deflect away from the scaffold **10**. When sheath **30** is moved distally of the scaffold **10** in FIG. 1, the halves **28**, **29** will tend to open up naturally, due to the preload applied by sheath **30** near hinge **26a** (the separable halves **28**, **29** can be more clearly seen in FIGS. 2A-2D). This arrangement for halves **29**, **28** allows sheath **20** it to be easily removed from the scaffold **10** with minimal disruption to scaffold-balloon structural integrity, after sheath **30** is moved to distal end **20b**. When sheath **30** is being fitted over the scaffold **10** or removed from the scaffold **10**, the presence of the halves **28**, **29** prevent direct contact between the sliding sheath **30** and the surface of the scaffold **10**.

At a proximal end **20a** of sheath **20** there are portions **24** and **25** formed when the combined proximal ends of halves **28**, **29** are brought together as in FIG. 1. When the halves **28**, **29** are brought together the portions **24** and **25** take the form of a stepped or notched portion **25** and a raised end **24** similar to end **22**, as shown in FIG. 1 and the cross-sectional view of the proximal end **20a** of the assembly of FIG. 1A. The notched or stepped portion **25** has an outer diameter less than the outer diameter of the portion **21** of the sheath that covers the scaffold **10**, as well as the outer diameter of the scaffold/balloon **10/12**. The raised end **24** has a diameter that is greater than the body portion **21**. The raised end **24** provides an abutment or stop **24a** preventing the proximal end **30a** of the sheath **30** from moving to the right in FIG. 1. As such, the end **24** prevents the sheath **30** from sliding off of the scaffold **10**. The portion **24** also serves to identify the approximate location of the sheath **30** proximal end **30a** so that it is fitted over the scaffold **10** and balloon **12**. Sheath **30** has a length about equal to the length of the portion **25** plus the scaffold/balloon length so that when end **30a** abuts end **24** the sheath **30** will properly cover the entire scaffold/balloon **10/12** length.

Portion **25** discourages removal of the sheath **20** prior to removal of sheath **30** from the scaffold **10**. FIG. 1A shows the distal end **20a** with the sheath **30** (shown in phantom) replaced by the inwardly directed preload **F30** it applies to sheath portion **21** when positioned over the scaffold **10**. A distal end of portion **25** forms a ledge **25a**. When sheath **30** is positioned over the scaffold **10** the inwardly directed preload **F30** applied to sheath portion **21** urges the halves **29**, **28** together. With the halves **28**, **29** urged together, the scaffold/balloon proximal end **14a** blocks movement of the sheath **20** to the left in FIG. 1A by interfering with the movement of the ledge **25a** to the left. Thus, if a user attempts to pull the sheath **20** off prior to removing the sheath **30** from the scaffold **10** area (which can damage the scaffold/balloon integrity), there will be resistance to this movement due to the ledges **25a** abutting the balloon proximal end **14a** (the ledge **25a** thus may be thought of as an interference or interfering ledge part of the sheath **20**). This resistance should indicate to the user that the sheaths **20**, **30** are being removed in an improper manner. When the sheaths **20**, **30** are removed properly, the

first sheath 30 is moved to the distal end 20b of the sheath 20 (thereby removing the preload F30) so that the halves 28, 29 freely open up to allow the ledge 25a to easily pass over the scaffold 10 so that sheath 20 is removed without resistance. The user is thereby informed that the sheath 20 is removed properly when there is no resistance to removing the sheath 20 from the balloon-catheter assembly 2.

Thus, scaffold-balloon integrity is protected by the presence of the halves 28, 29 and the notched portion 25, as discussed above. The extended length of sheath 20, beyond the tip 6, e.g., is about equal to a length of the scaffold 10, the length of the sheath 30 or greater than both. This length beyond the distal end 6 facilitates an intuitive sliding removal or attachment of the sheath 30 from/to the scaffold 10 by respectively sliding the sheath 30 along the sheath 20 extension that is distal of tip 6 of the catheter assembly 2. The length of the sheath 20 that extends beyond the distal end 4 of the catheter assembly 2 (length L21 in FIG. 4A) may depend on the choice of sheaths used. For example, from the perspective of the health professional removal process, if the sheath 20 is more stiff (e.g., higher wall thickness and/or modulus) relative to the sheath 30 then the length beyond distal end 4 for sheath 20 may be longer so that the halves 28, 29 sheath 20 can be more safely displaced from the scaffold 10 by clearing the sheath 30 more distally of the scaffold 10. If the sheath 30 wall thickness and/or modulus is higher relative to sheath 20 than the length may be shorter since the sheath 30 will tend to naturally open up the halves 28, 29 as it is moved distally of the tip 6. Also, a thicker or higher modulus sheath 20 and/or sheath 30 may be desirable to increase the resistance to improper removal of sheath 20, e.g., as when a user attempts to remove sheath 20 with, or before removing sheath 30 from the scaffold 10 (as discussed earlier).

Referring to FIGS. 2B-2D, there are shown various views of the sheath 20. FIG. 2A shows the sheath 20 with the sheath 30. As mentioned above sheath 30 is sized to have a length L30 such that sheath 30 applies a sufficiently uniform radial inward force or preload on the scaffold 10 when end 30a abuts end 24a. The length L30 should therefore be slightly greater than the length of the scaffold-balloon structure. The sheath 30 can be slid towards or away from the scaffold location (i.e., its location in FIG. 2A or FIG. 1) over the sheath outer surface 20. As noted earlier, the sheath 20 has separable upper and lower halves 29, 28 formed by a cut 26 made across the tube forming sheath 20. FIG. 2D is a perspective view of the upper and lower halves 28, 29 separated from each other. As can be appreciated from this view, the halves 28, 29 rotate about the hinge 26a when they separate. FIGS. 2B and 2C show an additional side and perspective view, respectively, of the sheath 20 showing the aforementioned structure, including the portions of notched or stepped portion 25 and end 24 discussed earlier.

The length L20 in FIG. 2C should be chosen to extend over the scaffold 10 length as well as a sufficient distance beyond the scaffold 10 so that the sheath 30 can be pushed onto the scaffold 10, and removed from the scaffold 10 while the halves 28, 29 are disposed over the scaffold 10. The length L20 may be at least twice the length of sheath 30, i.e., $L20=2*L30$, to achieve this purpose. This length should be sufficient to allow the upper and lower halves 28, 29 to peel or rotate about the living hinge 26a and freely away from the scaffold surface (as in FIG. 2D) without interference from the sheath 30.

As mentioned earlier, a thicker tube and smaller inner diameter for sheath 30 will cause the sheath 30 to apply a greater pre-load on the scaffold 10. The sheath 30 thickness and/or inner diameter size is selected with the sheath 20 in

mind. That is, the sizing of one can determine what sizing to use for the other, based on achieving an appropriate balance among the amount of pre-load F30 (FIG. 1A) desired, the ease in which the sheath 30 can be placed over or removed from the scaffold 10 location, increasing resistance to improper removal of sheath 20 (ledge 25a abutting proximal end 14a, as discussed above) and avoiding disruption to the integrity of the scaffold-balloon structure, e.g., pulling the scaffold 10 off the balloon when the sheath 30 is being removed. For example, if a relatively thin and/or low modulus tube is used for sheath 20 (as compared to sheath 30), the sheath 30 will impose a higher localized pre-load on the scaffold 10. And the scaffold 10 is more likely to be affected by sheath 30 movement because the sheath 20 easily deforms under the movement of the sheath 30. If the sheath 20 is made thick and/or a higher modulus tube material is used for sheath 20 (compared to sheath 30) the scaffold 10 will not be as affected by movement of the sheath 30. And local changes in pre-load on the scaffold 10 will tend to be lower since the sheath 20 does not deform as easily under the movement of the sheath 30.

Referring to FIGS. 3A-3D, methods of assembly using the sheaths 20, 30 (sheath pair) are now described. The scaffold 10 is crimped to the balloon 12 of the catheter assembly 2 using a crimping mechanism. As noted above, for a polymer scaffold the diameter reduction during crimping may be 2:1, 2.5:1, 3:1, 4:1 or higher. This diameter reduction introduces high stresses in the scaffold structure. The memory in the material following crimping causes recoil of the scaffold structure, as discussed earlier.

One can incorporate lengthy dwell times within the crimper, e.g., after the final crimp step, to allow stress-relaxation to occur in the structure while heated crimper blades are maintaining a fixed diameter and temperature to facilitate stress relaxation. Both the dwell period and the disposing of a constraining sheath over the crimped scaffold after crimping helps to reduce recoil after crimping. Crimping of the scaffold 10 to the balloon 12 including desirable dwell times and temperatures that can affect stress relaxation and recoil after crimping are disclosed in U.S. patent application Ser. No. 12/861,719, U.S. patent application Ser. No. 13/089,225 and U.S. patent application Ser. No. 13/107,666.

The sheath pair, shown in FIG. 3A, is placed on a mandrel 8 before being attached to the catheter assembly 2. The mandrel 8 is passed through the catheter shaft 4 guidewire lumen (not shown), and exits at the distal end 6 of the catheter assembly 2. The sheath pair is then placed on the mandrel 8 distally of the catheter assembly 2. The mandrel 8 is then used to guide the sheath pair over the scaffold-balloon 10/12 as illustrated in FIGS. 3B-3D.

Referring to FIG. 3B, the distal end 30a of the sheath 30 is adjacent to the raised end 22 of the sheath 20. In this configuration the halves 28, 29 can freely open or close. The sheath pair is then brought towards the scaffold-balloon 10/12. The halves 28, 29 easily deflect over the scaffold-balloon 10/12. The sheath pair may be slid towards the scaffold-balloon 10/12 as follows. Holding the catheter assembly 2 stationary, grasping the mandrel 8 with one hand and the sheath pair with the other hand and sliding the sheath pair over the mandrel 8 until the halves 28, 29 are located over the scaffold-balloon 10/12 as shown in FIG. 3C. When properly positioned, the portions 24, 25 are positioned with respect to proximal end 14a as shown in FIG. 1A.

Referring to FIGS. 3C-3D, once the halves 28, 29 are located properly over the scaffold-balloon 10/12 to protect this structure, the constraining sheath 30 can be pushed over the scaffold-balloon 10/12 (as indicated in FIGS. 3C-3D by P). The sheath 30 may be pushed over the scaffold-balloon

11

10/12 in the following manner. The raised end 22 and mandrel 8 are grasped with one hand to hold the two stationary. Then, using the other hand the sheath 30 is pushed over the scaffold-balloon 10/12 until the end 30a of sheath 30 is disposed adjacent to, or abuts the raised end 24 of the sheath 20, which indicates the proximate location of the proximal end 14a of the balloon-scaffold 10/12. Alternatively, the portion 24 and catheter shaft 4 may be simultaneously held with one hand, while the sheath 30 is pushed towards the scaffold 10 with the other hand. By grasping the portion 24 with the catheter shaft 4, the halves 28, 29 are held in place relative to the scaffold 10 while the sheath 30 is being pushed over the scaffold 10.

The catheter assembly 2 with sheaths arranged as in FIG. 4A is packaged and sterilized. At the time when the catheter assembly is to be used in a medical procedure the package is opened and the sheath pair removed from the distal end. The catheter assembly 2 is not configured for being introduced into the patient until the sheath pair is removed. FIGS. 1, 1A and 4A depict the arrangement of the sheaths 20, at the distal end of the catheter assembly 2 when the packaged and sterile medical device is received by a health professional. Examples of such sterile packaging is found in U.S. patent publication no. US 2008-0010947. The sheath 20 extends well-beyond the distal end 6 of the catheter 2 assembly such that it overhangs the distal end 6. The overhanging portion of the sheath 20, which has a length of more than L21 (FIG. 4A), is provided to facilitate a safe and intuitive removal of the sheath pair by a health professional, thereby reducing the chances that the sheath pair are removed improperly.

Referring to FIGS. 4B-4C, methods for removing the sheath pair from the scaffold-balloon 10/12 by the health professional are now described. These illustrations refer to moving the sheath pair over the mandrel 8; however, a mandrel 8 is not necessary. The sheath pair may be safely removed from the catheter assembly 2 without using a mandrel 8.

A sterilized and packaged catheter assembly with sheaths 20, 30 positioned as shown in 4A typically includes the stiffening mandrel 8 in the catheter shaft 4 lumen to provide bending stiffness for shaft 4. A distal end of the mandrel 8 has a curled end, or an extension/stop at the distal end (not shown), which is used to manually withdraw the mandrel 8 from the catheter shaft 4 lumen by pulling the mandrel 8 towards the distal end 6 of the catheter assembly 2. In the following example the sheaths 20, 30 are removed. The prescribed steps preferably also include the act of removing the mandrel 8 from the catheter shaft lumen by, e.g., simultaneously gripping the raised end 22, sheath 30 and mandrel 8.

First, the sheath 30 is pulled away from the scaffold-balloon 10/12 structure, where it is shown positioned in FIG. 4A. The sheath 30 may be withdrawn or pulled away from the scaffold-balloon 10/12 in the following manner. One hand grasps the raised end 22 and mandrel 8, to hold the two stationary, while the other hand grasps and pulls the sheath 30 towards the raised end 22. When the sheath 30 reaches the raised end 22 the halves 28, 29 should freely deflect away from the scaffold 10 surface, since a majority if not all of the cut 26 is to the left of the sheath 30 (FIG. 4B). At this point both sheaths 20, 30 can be simultaneously pulled away from the scaffold-balloon 10/12.

As an alternative, the sheaths 20, 30 may be removed by grasping the catheter assembly distal portion, e.g., the catheter shaft 4, and optionally portion 24 as well with one hand and grasping and pulling the sheath 30 distally of the catheter assembly 2 with the other hand. Once the sheath 30 has abutted the raised end 22 (and removing hand from portion 24, if being gripped with shaft 4), continued pulling on the sheath 30 distally can safely remove both sheaths without risk

12

of dislodging the scaffold 10 from the balloon. The pulling of the sheath 30 distally, while it abuts the raised end 22, causes both the sheath 20 and the sheath 30 to be removed from the scaffold-balloon 10/12. The raised end 22 therefore functions as an abutment for removing both sheaths in a safe manner with minimal disruption to the crimped scaffold. This final pulling away of the sheath 20 from scaffold 10 may also simultaneously remove the stiffening mandrel 8 from the catheter shaft 4 lumen.

As discussed earlier, the assembly of sheaths 20, 30 discourages a health professional from removing the sheath 20 before sheath 30 is moved to end 22. For example, if a health professional were to pull on the end 22 while the sheath 30 is positioned over the scaffold, the ledges 25a abutting proximal end 14a will interfere with distal movement of the sheath (FIG. 1A). When this resistance is felt, this should indicate to the health professional that the sheath 20 is being removed in an improper manner. If the sheath 30 is first moved to end 22, then the sheath 20 can be pulled off of the catheter distal end 6 very easily since the halves 29, 28 (free of the preload F30) will easily open up and pass over the scaffold 10.

Referring to FIGS. 5A-5B there is illustrated an alternative embodiment of the sheath 20, which will be referred to as sheath 200. This sheath has raised abutments or surfaces 224, 222 formed at the distal and proximal ends of sheath 200. Otherwise the sheath 200 has the same construction as sheath 20. The raised end 224 forms proximal ends of halves 228, 229. And the sheath 200 has the cut 226 and hinge point 226a.

The proximal abutment 224 is shown in a frontal view in FIG. 5B. In this view the abutment 224 may take the form of a cross having ends 225a, 225b, 225c and 225d. The ends 225 form raised abutment surfaces that prevent or resist the sheath 30 from being moved to the left of the sheath 200 when the two are positioned over the scaffold. For example, when the packaged catheter assembly is being transported to a medical facility, the sheath 30 may slip proximally of the scaffold 10, thereby removing the constraint on the scaffold. By placing the abutment 225 at the proximal end of the sheath 200, the sheath 30 cannot move proximally. The same type of abutment 222 may also be formed at the distal end.

In a method of assembly the raised ends 222, 224 may be formed after the sheaths 20, 30 have been positioned over the scaffold-balloon 10/12 structure using, e.g., a hand crimper. The hand crimper is applied at the location 224 to form the cross members 225 (FIG. 5B) and also at the distal end of sheath 200 a similar structure 222.

The above description of illustrated embodiments of the invention, including what is described in the Abstract, is not intended to be exhaustive or to limit the invention to the precise forms disclosed. While specific embodiments of, and examples for, the invention are described herein for illustrative purposes, various modifications are possible within the scope of the invention, as those skilled in the relevant art will recognize.

These modifications can be made to the invention in light of the above detailed description. The terms used in the following claims should not be construed to limit the invention to the specific embodiments disclosed in the specification. Rather, the scope of the invention is to be determined entirely by the following claims, which are to be construed in accordance with established doctrines of claim interpretation.

What is claimed is:

1. An apparatus, comprising:
 - a catheter assembly having a distal end and including a scaffold comprising a polymer crimped to a balloon, the scaffold having a length;

13

a protecting sheath disposed over the scaffold, extending distally of the distal end, and having a total length that is a sum of a first length and a second length, wherein the first length is about the scaffold length, the second length is equal to or greater than the first length, and the second length is about equal to an amount that the protecting sheath extends distally of the distal end; and

a constraining sheath disposed over the protecting sheath and the scaffold to limit recoil of the scaffold by applying an inwardly directed radial force on the scaffold; wherein the apparatus is configured for being passed through a body only after the constraining and protecting sheaths are removed.

2. The apparatus of claim 1, wherein the protecting sheath includes a first and second separable half forming a proximal portion of the protecting sheath.

3. The apparatus of claim 1, wherein the protecting sheath includes a first protecting sheath portion and a second protecting sheath portion spanning the first length and the second length, respectively,

wherein the first protecting sheath portion comprises a cut forming halves of the protecting sheath, and wherein the second protecting sheath portion is substantially devoid of the cut.

4. The apparatus of claim 3, wherein the second protecting sheath portion includes a raised portion located distally and proximally of the first protecting sheath portion.

5. An apparatus, comprising:

a catheter assembly having a distal end and including a scaffold comprising a polymer crimped to a balloon, the scaffold having a length;

a sheath disposed over the scaffold and extending distally of the catheter distal end by about a length equal to the scaffold length;

the sheath including a protecting sheath disposed over the scaffold and a constraining sheath disposed over the protecting sheath and the scaffold to limit recoil of the scaffold by applying an inwardly directed radial force on the scaffold, wherein the protecting sheath includes an abutment having an extent capable of preventing the constraining sheath from being disposed proximally of a proximal end of the scaffold and balloon; and

wherein the apparatus is configured for being passed through a body only after the constraining and protecting sheaths are removed.

6. The apparatus of claim 5, wherein the abutment comprises a crimped portion of the protecting sheath.

7. An apparatus, comprising:

a scaffold crimped to a balloon of a catheter, the catheter having a distal end and the scaffold being crimped to the balloon proximally of the distal end;

a first sheath disposed over the scaffold, the first sheath including an extension that is disposed distally of the catheter distal end; and

a second sheath disposed over the scaffold;

wherein the first sheath and second sheath are arranged relative to each other such that the apparatus is capable of being configured into a medical device suitable for being introduced into a patient by (a) pulling the second sheath distally along the first sheath outer surface such that the second sheath is displaced to a location substantially distal of the scaffold or the catheter distal end, and (b) after the first sheath has been moved to the substantially distal location, removing the first sheath from the scaffold by pulling the second sheath against the first sheath extension, thereby displacing the first sheath distally with the second sheath.

14

8. The apparatus of claim 7, the catheter having a shaft and the shaft having a lumen, further including

a mandrel disposed within the shaft lumen;

wherein the mandrel, first sheath and second sheath are arranged relative to each other such that the apparatus is capable of being configured into a medical device suitable for being introduced into a patient by simultaneously removing the mandrel from the lumen and the first sheath from the scaffold by pulling the second sheath against the first sheath extension while gripping the mandrel, thereby displacing the first sheath distally with the second sheath and removing the mandrel from the catheter shaft lumen.

9. The apparatus of claim 7, wherein the first sheath extension has a length about equal to the length of the second sheath.

10. The apparatus of claim 9, wherein the first sheath extension includes an abutment preventing removal of the second sheath from the first sheath extension when the second sheath is displaced to the location substantially distal of the scaffold or the catheter distal end.

11. An apparatus, comprising:

a scaffold crimped to a balloon of a catheter, the catheter having a distal end and the scaffold being crimped to the balloon proximally of the distal end;

a first sheath disposed over the scaffold, the first sheath including a distal extension disposed distally of the catheter distal end and a notched portion disposed proximally of the scaffold; and

a second sheath disposed over the scaffold and first sheath, the second sheath applying a preload to the scaffold and the first sheath to maintain contact between the first sheath and scaffold;

wherein the first sheath is removable from the scaffold only after the second sheath has been moved to the distal extension such that the notched portion is capable of deflecting away from the scaffold only when the second sheath is removed from the scaffold; and

wherein the apparatus is configured as a medical device suitable for being introduced into a patient when the first and second sheaths are removed from the catheter.

12. The apparatus of claim 11, wherein the first sheath includes an upper and lower half which together form the notched portion.

13. The apparatus of claim 12, wherein the first sheath includes a raised portion disposed proximally of the notched portion.

14. An apparatus, comprising:

a catheter assembly having a distal end and including a scaffold comprising a polymer crimped to a balloon, the scaffold having a length;

a sheath disposed over the scaffold and applying a radial inward force on the scaffold to limit recoil of the scaffold;

the sheath comprises a protecting sheath and a constraining sheath disposed on the protecting sheath, wherein the sheath extends distally of the catheter distal end by about a length equal to the length of the scaffold; and

the protecting sheath includes a first and second separable half forming a proximal portion of the protecting sheath, wherein the first and second separable halves terminate at about the catheter distal end or a scaffold distal end and form a living hinge, and wherein the first and second separable halves separate from each other when the constraining sheath is disposed on the protecting sheath and substantially distal of the living hinge;

wherein the apparatus is configured for being passed through a body only after the constraining and protecting sheaths are removed.

15. The apparatus of claim **14**, wherein the protecting sheath is at least twice the length of the constraining sheath. 5

16. The apparatus of claim **14**, wherein the protecting sheath extends distally of the distal end by at least the scaffold length.

17. The apparatus of claim **16**, wherein the protecting sheath extends distally of the distal end by more than the scaffold length. 10

18. The apparatus of claim **14**, wherein the protecting sheath includes an interfering ledge preventing removal of the protecting sheath when the constraining sheath is disposed over the scaffold. 15

19. The apparatus of claim **18**, wherein a first and second portion of the interfering ledge are separated from each other by a radial force applied by the constraining sheath on the protecting sheath when the constraining sheath is substantially distal of the living hinge. 20

* * * * *