



US008406443B2

(12) **United States Patent**
Westerkull et al.

(10) **Patent No.:** **US 8,406,443 B2**
(45) **Date of Patent:** **Mar. 26, 2013**

(54) **BONE ANCHORED BONE CONDUCTIVE HEARING AID**

(75) Inventors: **Patrik Westerkull**, Smørum (DK); **Lars Jinton**, Smørum (DK)

(73) Assignee: **Oticon Medical A/S**, Smørum (DK)

(*) Notice: Subject to any disclaimer, the term of this patent is extended or adjusted under 35 U.S.C. 154(b) by 486 days.

(21) Appl. No.: **12/780,560**

(22) Filed: **May 14, 2010**

(65) **Prior Publication Data**

US 2010/0292529 A1 Nov. 18, 2010

(30) **Foreign Application Priority Data**

May 14, 2009 (EP) 09160282

(51) **Int. Cl.**
H04R 25/02 (2006.01)
H04R 25/00 (2006.01)

(52) **U.S. Cl.** **381/326**; 381/151; 381/380; 600/25

(58) **Field of Classification Search** 381/326, 381/322, 23.1, 151, 380, 374; 606/72, 75, 606/129; 600/379, 25; 607/137
See application file for complete search history.

(56) **References Cited**

U.S. PATENT DOCUMENTS

3,732,621	A	5/1973	Bostrom	
4,498,461	A *	2/1985	Hakansson	600/25
4,793,808	A	12/1988	Kirsch	
4,904,233	A *	2/1990	Håkansson et al.	600/25
5,087,200	A	2/1992	Brajnovic et al.	
5,135,395	A	8/1992	Marlin	

5,571,015	A	11/1996	Siegmund	
5,735,790	A *	4/1998	Håkansson et al.	600/25
RE35,784	E	5/1998	Linkow et al.	
5,935,170	A *	8/1999	Håkansson et al.	600/25
6,053,920	A	4/2000	Carlsson et al.	
7,021,676	B2 *	4/2006	Westerkull	285/321
7,065,223	B2 *	6/2006	Westerkull	381/326
7,116,794	B2 *	10/2006	Westerkull	381/326
7,160,244	B2 *	1/2007	Westerkull	600/25
7,198,596	B2 *	4/2007	Westerkull	600/25
7,376,237	B2 *	5/2008	Westerkull	381/326
7,409,070	B2 *	8/2008	Pitulia	381/326
8,005,247	B2 *	8/2011	Westerkull	381/318
8,059,844	B2 *	11/2011	Westerkull et al.	381/322
8,144,908	B2 *	3/2012	Åsnes	381/326
8,184,840	B2 *	5/2012	Spitaels et al.	381/326
8,216,287	B2 *	7/2012	Parker	606/300
2005/0249366	A1 *	11/2005	Westerkull	381/151

(Continued)

FOREIGN PATENT DOCUMENTS

DE	2802602	A1	8/1978
EP	0216031	A1	4/1987

(Continued)

Primary Examiner — Edgardo San Martin

(74) *Attorney, Agent, or Firm* — Birch, Stewart, Kolasch & Birch, LLP

(57) **ABSTRACT**

The invention relates to a bone anchored bone conductive hearing aid which has a bone implantable screw (3) with an implant axis (25) intended to be generally perpendicular to a bone surface at an implant point and a skin penetrating abutment (5) which is connected to the implantable screw (3) through a contact surface (16) at a contra-lateral end thereof where the abutment (5) at a lateral end thereof has a coupling surface (15) whereto a hearing aid is detachably coupled along a hearing aid coupling axis (20) the implant axis (25) and the hearing aid coupling axis (20) are arranged at an angle α with respect to each other.

7 Claims, 5 Drawing Sheets

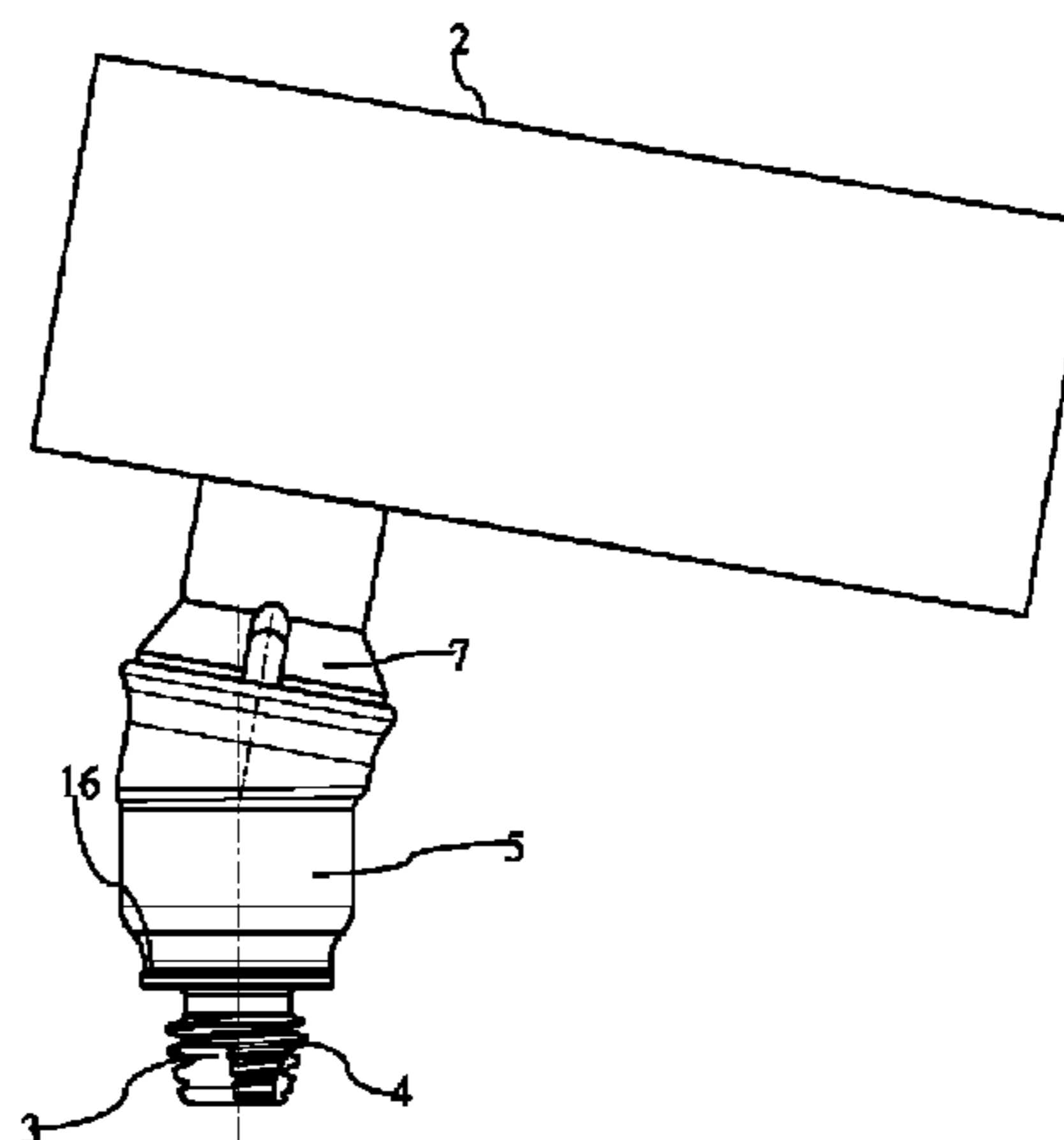
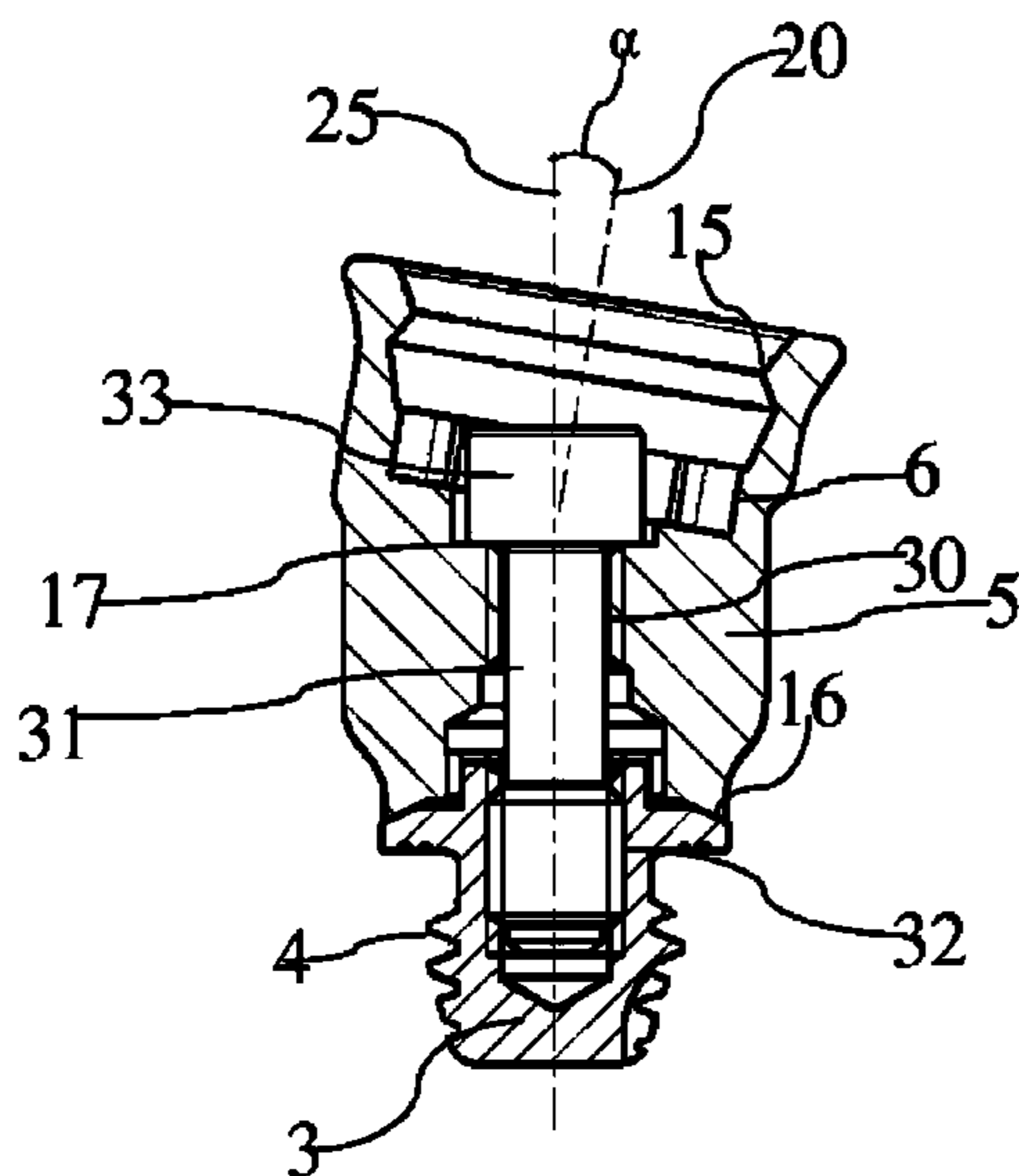

US 8,406,443 B2

Page 2

U.S. PATENT DOCUMENTS

2006/0126874 A1* 6/2006 Westerkull 381/326
2006/0211910 A1* 9/2006 Westerkull 600/25
2007/0009853 A1* 1/2007 Pitulia 433/173
2007/0053536 A1* 3/2007 Westerkull 381/326
2009/0082817 A1* 3/2009 Jinton et al. 606/301
2009/0245554 A1* 10/2009 Parker 381/326
2009/0248023 A1* 10/2009 Parker 606/60
2010/0286776 A1* 11/2010 Andersson 623/16.11
2011/0158443 A1* 6/2011 snes et al. 381/326
2012/0078035 A1* 3/2012 Andersson et al. 600/25
2012/0095284 A1* 4/2012 Westerkull et al. 600/25

2012/0172658 A1* 7/2012 Bjorn et al. 600/25
2012/0215056 A1* 8/2012 Hillbratt et al. 600/25

FOREIGN PATENT DOCUMENTS

EP 0323421 A2 7/1989
EP 0497082 A1 8/1992
EP 0715839 A2 6/1996
EP 1547543 A1 6/2005
WO WO 83/02047 A1 6/1983
WO WO 98/55049 A1 12/1998
WO WO 2007/024657 A2 3/2007

* cited by examiner

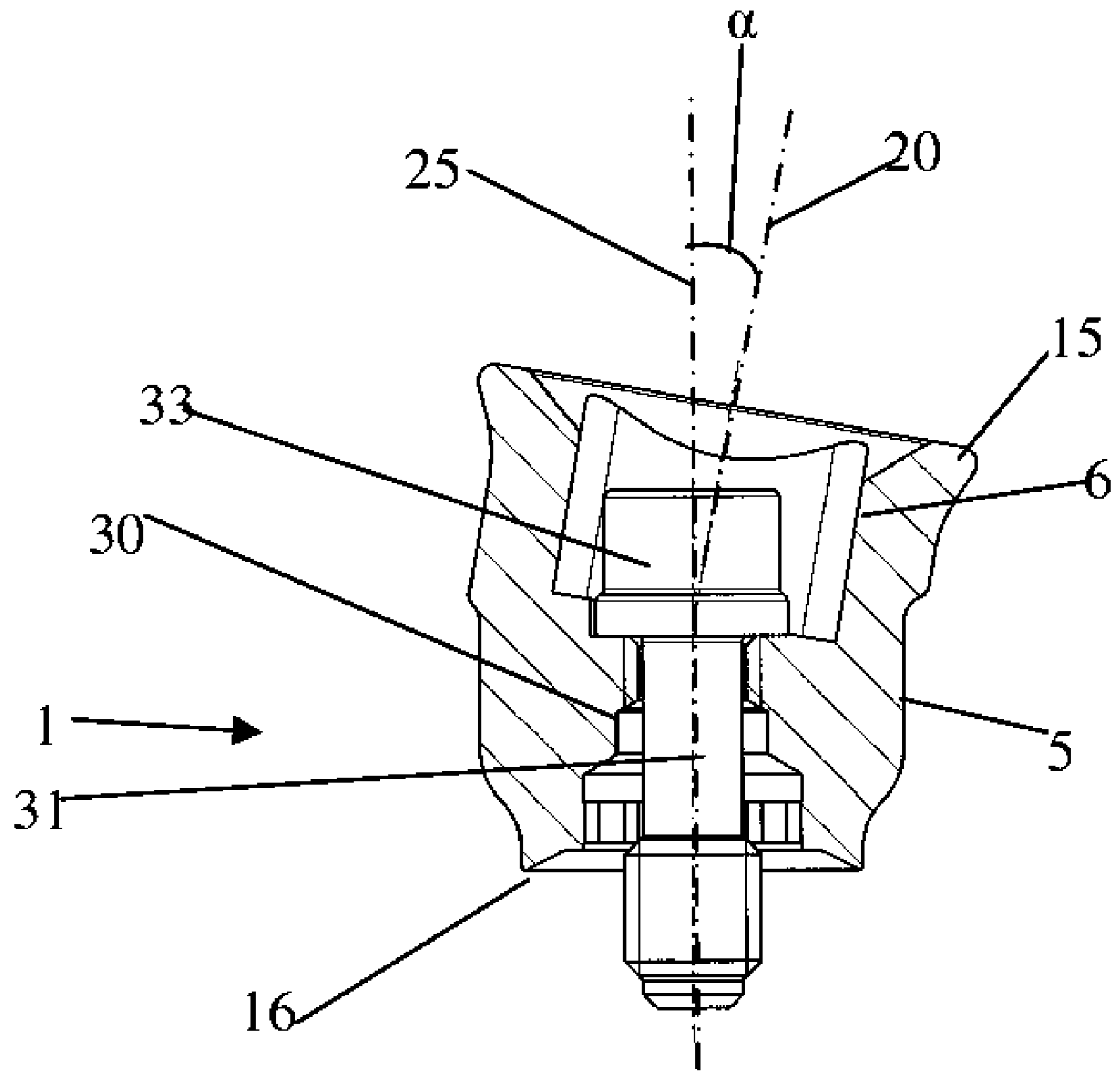

Fig. 1

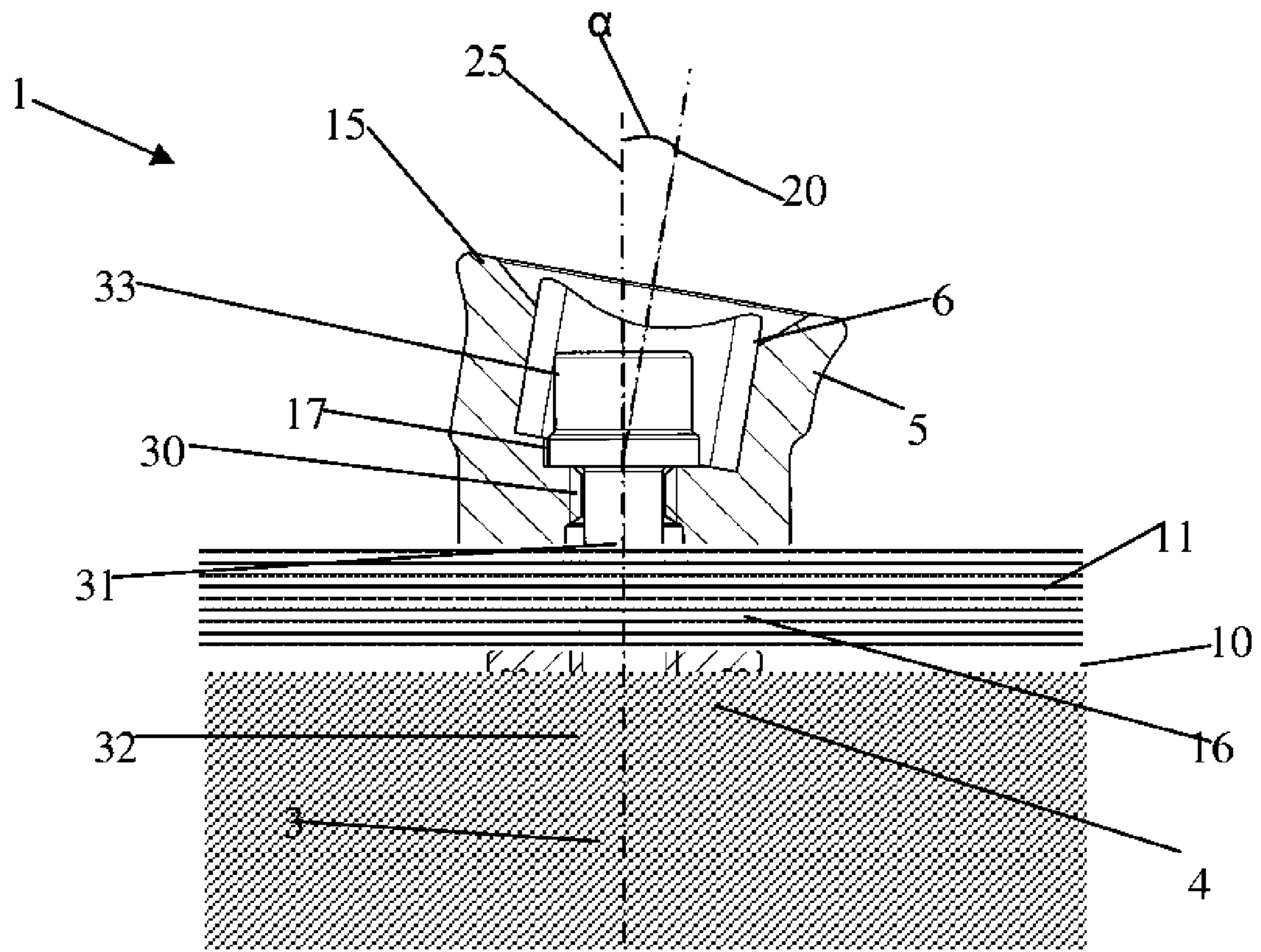

Fig. 2

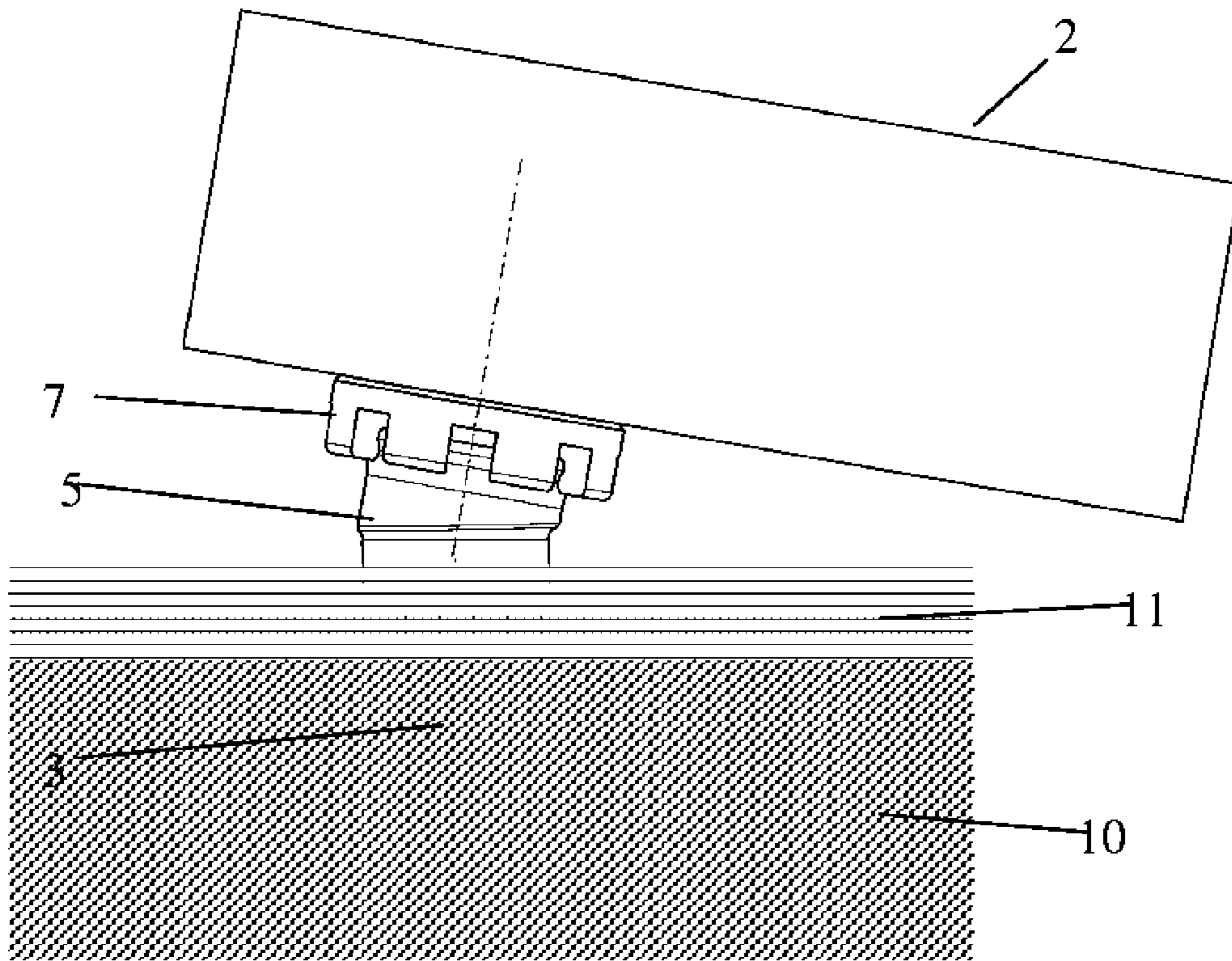

Fig. 3

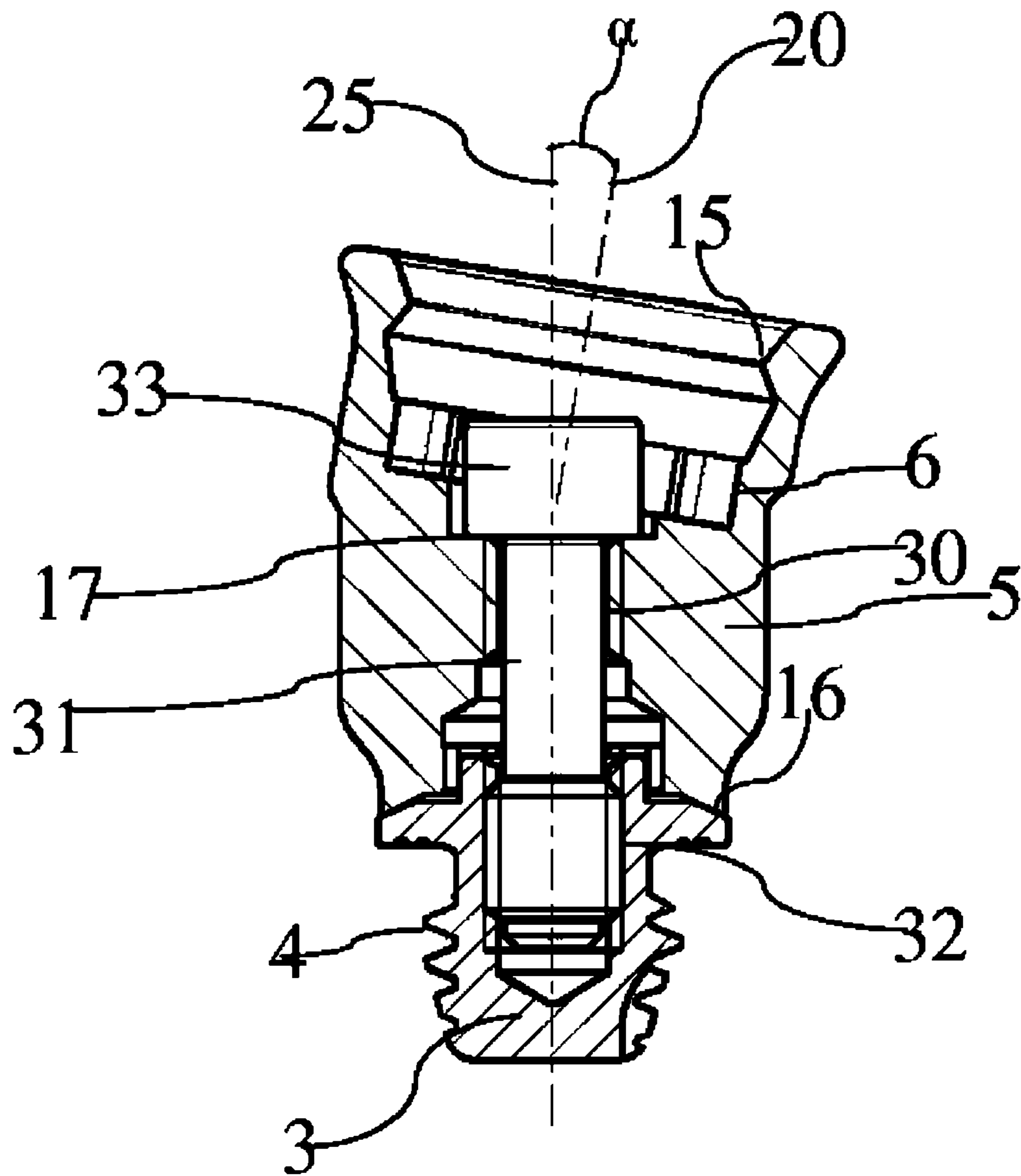

Fig. 4

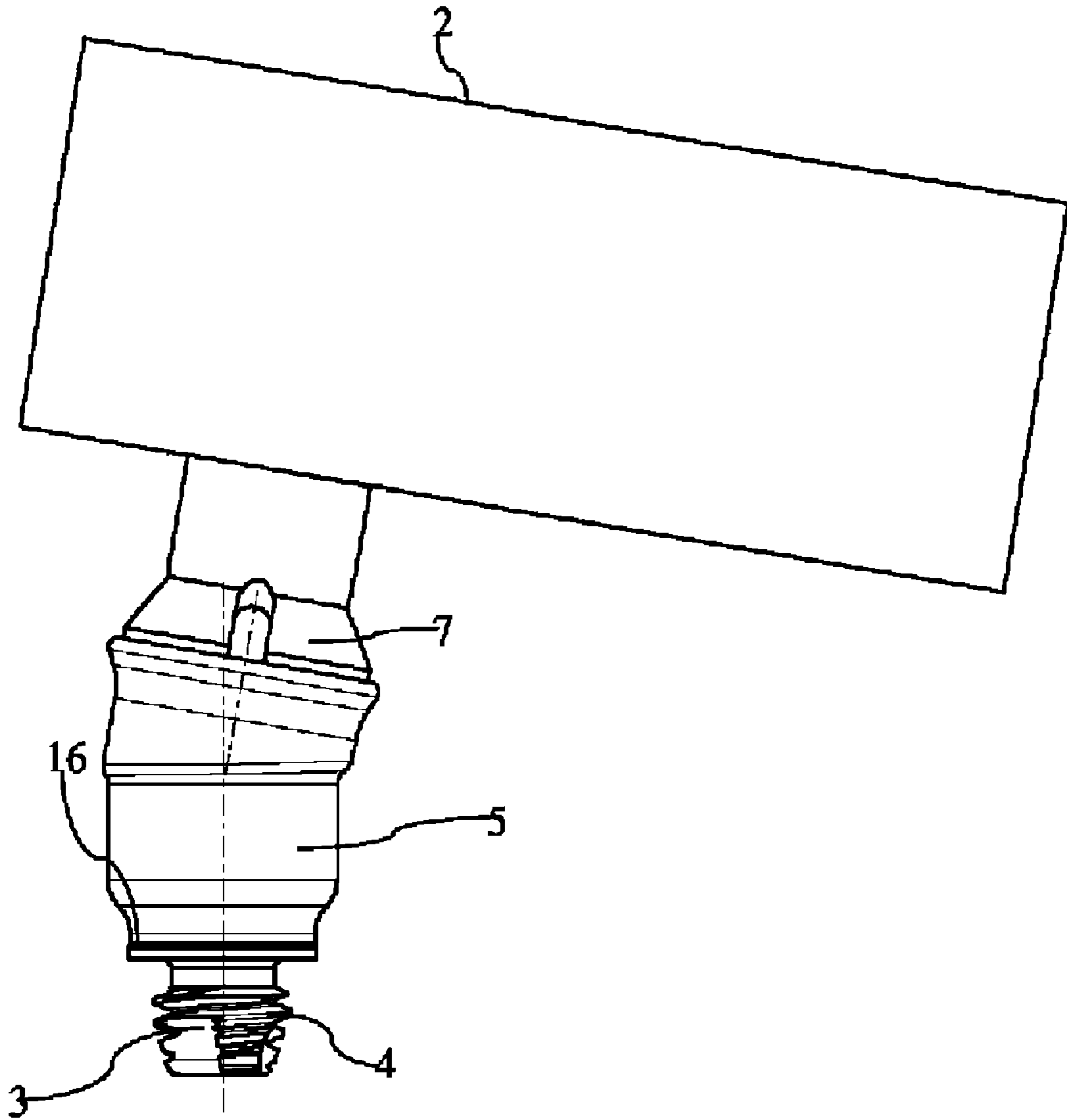

Fig. 5

BONE ANCHORED BONE CONDUCTIVE HEARING AID

TECHNICAL FIELD

The present invention relates to a bone anchored bone conductive hearing aid. The invention relates specifically to a bone anchored bone conductive hearing aid which has a bone implantable screw with an implant axis intended to be generally perpendicular to a bone surface at an implant point and a skin penetrating abutment which is connected to the implantable screw through a contact surface at a contra-lateral end thereof where the abutment at a lateral end thereof has a coupling surface whereto a hearing aid is detachably coupled along a hearing aid coupling axis.

BACKGROUND ART

Bone anchored bone conduction hearing aids are essential for the rehabilitation of patients suffering from some specific type of hearing loss for which traditional hearing aids are insufficient. This type of device consists of an external hearing aid with a vibrating transducer which is connected via a coupling to a skin penetrating abutment mounted on an implant fixture anchored in the skull bone. It is important that the coupling is sufficiently firm, to avoid poor transmission of the vibrations, but it is also important that the coupling is not too firm, since it is also important that the hearing aid falls off in case of a sudden impact, to avoid that the skull bone anchoring is damaged. In a coupling like this there are always coupling forces pressing components in the connection against the abutment. The coupling forces can be generated by a separate spring, a flexible material or by a magnet. The patient takes on and off the hearing aid daily, so wear and tear durability of the coupling is also important.

DISCLOSURE OF INVENTION

In some cases with conventional implant systems, the implant fixture, anchored in the skull bone, can end up in an unsuitable position due to anatomical variations.

An object of the present invention is to provide a hearing aid which overcomes this problem.

The object of the invention is achieved by a bone anchored hearing aid as defined above wherein the implant axis and the hearing aid coupling axis are arranged at an angle α with respect to each other

By providing such an angle between the two axes it is ensured that the hearing aid may rest coupled on the abutment, without touching the skin of the user at any other point.

Further objects of the invention are achieved by the embodiments defined in the dependent claims and in the detailed description of the invention.

As used herein, the singular forms "a," "an," and "the" are intended to include the plural forms as well (i.e. to have the meaning "at least one"), unless expressly stated otherwise. It will be further understood that the terms "includes," "comprises," "including," and/or "comprising," when used in this specification, specify the presence of stated features, integers, steps, operations, elements, and/or components, but do not preclude the presence or addition of one or more other features, integers, steps, operations, elements, components, and/or groups thereof. It will be understood that when an element is referred to as being "connected" or "coupled" to another element, it can be directly connected or coupled to the other element or intervening elements maybe present, unless expressly stated otherwise.

BRIEF DESCRIPTION OF DRAWINGS

The invention will be explained more fully below in connection with a preferred embodiment and with reference to the drawings in which:

FIG. 1 shows a sectional side view of the angled abutment with a connection screw,

FIG. 2 shows a sectional side view of the angled abutment with the connection screw joined with the implant fixture, and

FIG. 3 shows a bone anchored hearing aid attached to the angled abutment,

FIG. 4 shows a sectional side view of the angled abutment, with an internal flange portion arranged for the connection of a vibrator unit,

FIG. 5 shows a bone anchored hearing aid attached to the angled abutment at the internal flange portion thereof.

The figures are schematic and simplified for clarity, and they just show details which are essential to the understanding of the invention, while other details are left out. Throughout, the same reference numerals are used for identical or corresponding parts.

Further scope of applicability of the present invention will become apparent from the detailed description given hereinafter. However, it should be understood that the detailed description and specific examples, while indicating preferred embodiments of the invention, are given by way of illustration only, since various changes and modifications within the spirit and scope of the invention will become apparent to those skilled in the art from this detailed description.

A hearing-aid attachment system 1 for connection of a bone conduction hearing aid (FIG. 3, position No 2) to an osseointegrated implant 3 is shown in FIG. 2 and FIG. 4. The system comprises an implant 3 which is fixated in the bone 10 of a wearer as especially indicated in FIGS. 2 and 3. As seen in the figures the implant 3 comprises a screw 3 with an external thread 4, and an abutment 5 that goes through the skin 11. A hearing aid 2 has a coupling 7 that allows the hearing aid 2 to be connected to the abutment 5, as is seen in FIGS. 3 and 5. To this end the abutment 5 has a coupling surface 15 at its lateral end. (With "lateral" is to be understood a direction away from the bone or skin surface whereas contra-lateral is to be understood as a direction towards the skin and bone surface of a wearer) This coupling surface 15 is in contact with the hearing aid coupling 7. In the embodiment in FIGS. 4 and 5, the coupling surface is provided at an internal circumference of the cup shaped abutment 5. As seen in FIGS. 3 and 5, the axial orientation of the hearing aid coupling 7 in relation to the implanted screw 3 is decided by the axial orientation of the coupling surface 15 when the hearing aid 2 is attached to the abutment 5. The abutment 5 has an implant contact surface 16 at a contra-lateral end thereof and this surface 16 is in contact with a lateral end of the implant 3. A hearing aid coupling axis 20 is defined by the coupling surface 15, and an implant axis 25 is defined by the implant screw 3. As seen in FIG. 1 the abutment is designed so that there is an angle α between the hearing aid coupling axis 20 and the implant axis 25.

Generally the implant screw 3 is to be implanted perpendicular to the bone surface, but this is not always a well defined direction as the surface of the bone is not necessarily even, and also during the implant procedure some variation in the screw placement may follow due to the craftsman nature of this procedure.

The angle α is preferably in the range between 5 and 20 degrees.

3

Preferably the angle α is provided by an angulation of the coupling surface **15** and the contact surface **16** with respect to each other.

Both the coupling surface **15** and the contact surface **16** are circular. This allows the abutment **5** to be turned around the axis **25** and fastened at any rotational angle with respect to the implant screw **3**, whereby the angle α may be freely rotated about the implant axis **25**.

As seen in FIGS. **1**, **2** and **4**, the abutment has a central hole **30** and a connection screw **31** where, as further seen in FIGS. **2** and **4** the implant **3** has a threaded inner hole **32** for the connection screw **31**. The axial orientation of the connection screw **31** corresponds to the axial orientation of the implant screw **3**.

At the lateral end the abutment **5** comprises a recess **6**, which is shaped such that a head **33** of screw **31** may be seated therein. The recess **6** thus comprises a seat surface **17** for the screw head **33** arranged perpendicular to the implant axis **25**. In this way the head **33** of the connection screw **31** can be accessed from the lateral end of the abutment **5**, and the screw **31** may be tightened in the threaded hole **32** to establish a strong sealing force between the abutment contact surface **16** and the implanted screw **3**, through tightening forces imparted onto the surface **17**.

In a further embodiment (not shown in the drawing) the abutment coupling contact surface is a spherical surface and the hearing aid coupling has a corresponding reverse spherical surface, and further, the hearing aid coupling is magnetically attached to the abutment coupling contact surface. This allows the angle α to be varied by attaching the hearing aid coupling on different locations on the spherical abutment coupling contact surface.

The invention is defined by the features of the independent claim(s). Preferred embodiments are defined in the dependent claims. Any reference numerals in the claims are intended to be non-limiting for their scope.

4

Some preferred embodiments have been shown in the foregoing, but it should be stressed that the invention is not limited to these, but may be embodied in other ways within the subject-matter defined in the following claims.

The invention claimed is:

1. Bone anchored bone conductive hearing aid which has a bone implantable screw (**3**) with an implant axis (**25**) intended to be generally perpendicular to a bone surface at an implant point and a skin penetrating abutment (**5**) which is connected to the implantable screw (**3**) through a contact surface (**16**) at a contra-lateral end thereof where the abutment (**5**) at a lateral end thereof has a coupling surface (**15**) whereto a hearing aid is detachably coupled along a hearing aid coupling axis (**20**), wherein the implant axis (**25**) and the hearing aid coupling axis (**20**) are arranged at an angle α with respect to each other.

2. Bone anchored bone conductive hearing aid as claimed in claim **1** wherein the angle α is in the range between 5 and 20 degrees.

3. Bone anchored bone conductive hearing aid as claimed in claim **2** wherein the coupling surface (**15**) and the contact surface of the abutment (**5**) are circular.

4. Bone anchored bone conductive hearing aid as claimed in claim **3** wherein the abutment comprise a through going hole (**30**) for a fastening screw (**31**), and where the screw and screw hole is aligned along the implant axis (**25**).

5. Bone anchored bone conductive hearing aid as claimed in claim **4** wherein a recess (**6**) is provided at the lateral end of the abutment (**5**) for receiving a screw head (**33**) of the fastening screw (**31**).

6. Bone anchored bone conductive hearing aid as claimed in claim **5** wherein the recess (**6**) at the contra lateral end thereof comprise a seat surface for the screw head (**33**) arranged perpendicular to the implant axis (**25**).

7. Bone anchored bone conductive hearing aid as claimed in claim **1** wherein the hearing aid is magnetically attached to the skin penetrating abutment (**5**).

* * * * *