

US008398641B2

(12) **United States Patent**
Wallace et al.

(10) **Patent No.:** **US 8,398,641 B2**
(45) **Date of Patent:** **Mar. 19, 2013**

(54) **TISSUE MODIFICATION DEVICES AND METHODS**

(75) Inventors: **Michael P. Wallace**, Pleasanton, CA (US); **Robert Garabedian**, Sunnyvale, CA (US); **Nestor C. Cantorna**, Union City, CA (US); **Jeffery L. Bleich**, Palo Alto, CA (US); **Roy Leguidleguid**, Union City, CA (US); **Ronald Leguidleguid**, Union City, CA (US)

(73) Assignee: **Baxano, Inc.**, San Jose, CA (US)

(*) Notice: Subject to any disclaimer, the term of this patent is extended or adjusted under 35 U.S.C. 154(b) by 0 days.

(21) Appl. No.: **13/338,103**

(22) Filed: **Dec. 27, 2011**

(65) **Prior Publication Data**
US 2012/0095468 A1 Apr. 19, 2012

Related U.S. Application Data

(63) Continuation-in-part of application No. 12/773,595, filed on May 4, 2010, and a continuation-in-part of application No. 12/496,094, filed on Jul. 1, 2009, said application No. 12/773,595 is a continuation-in-part of application No. PCT/US2009/050492, filed on Jul. 14, 2009.

(Continued)

(51) **Int. Cl.**
A61B 17/00 (2006.01)

(52) **U.S. Cl.** **606/79**

(58) **Field of Classification Search** 606/79, 606/82, 84, 85, 176, 177; 407/29.11

See application file for complete search history.

(56) **References Cited**

U.S. PATENT DOCUMENTS

184,804 A	11/1876	Stohlmann
289,104 A	11/1883	How
863,389 A	8/1907	Harkin
1,039,487 A	9/1912	Casebolt
1,201,467 A	10/1916	Hoglund
1,374,638 A	4/1921	De Cew et al.
1,543,195 A	6/1925	Thygesen

(Continued)

FOREIGN PATENT DOCUMENTS

DE	3209403 A1	9/1983
DE	4036804 A1	5/1992

(Continued)

OTHER PUBLICATIONS

Bleich et al.; U.S. Appl. No. 13/484,744 entitled "Devices and Methods for Tissue Modification," filed May 31, 2012.

(Continued)

Primary Examiner — Nicholas Woodall
(74) *Attorney, Agent, or Firm* — Shay Glenn LLP

(57) **ABSTRACT**

Described herein are devices and methods for cutting tissue in a patient. In some embodiments, a bimanually controlled device may include a tissue modification region; at least two flexible elongate lengths of cable that extend substantially adjacent to each other proximally to distally; a plurality of rungs extending between the lengths of cable; and a pair of flexible elongate cutting members extending along the length of the tissue modification region of the device. Each elongate cutting member has a thickness cuts a discrete trough into tissue to a depth that is greater than the thickness of the cutting member. The device may further include a substrate sized and configured to releasably hold the cutting members a distance from one another and a pair of couplers positioned toward an outer edge region of the substrate and configured to releasably secure a cutting member to the outer edge region of the substrate.

17 Claims, 31 Drawing Sheets

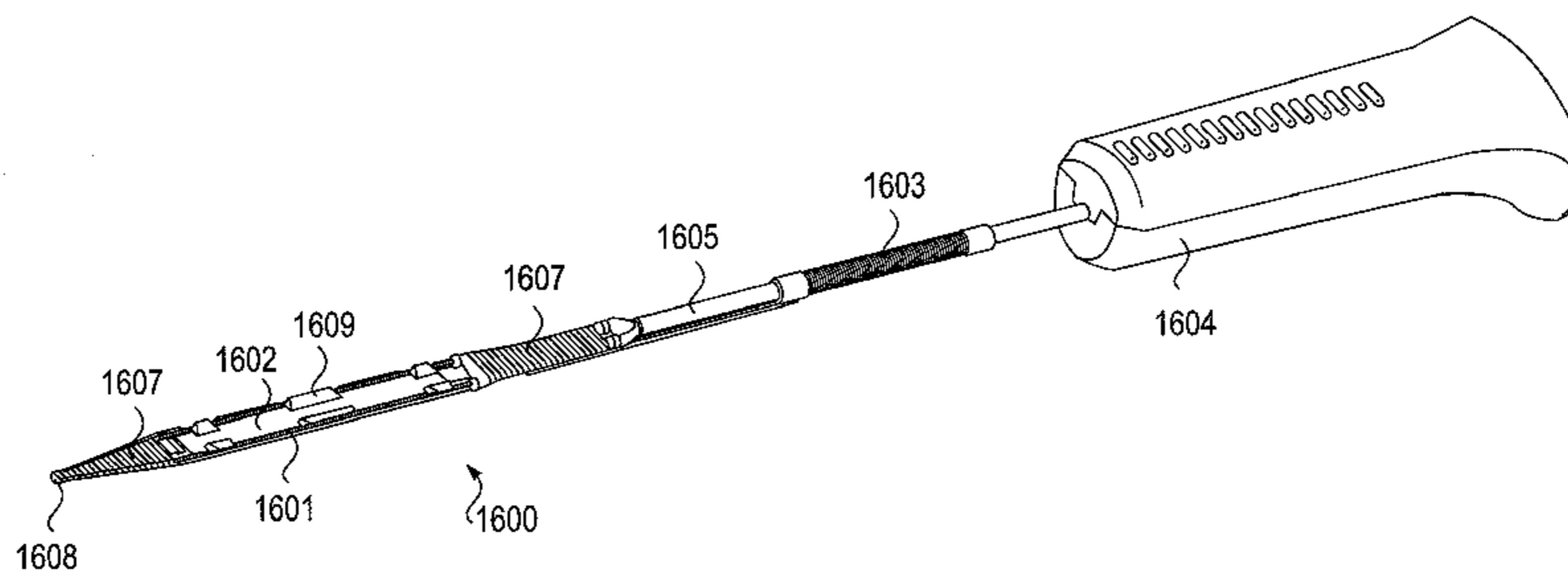

Related U.S. Application Data

(60) Provisional application No. 61/175,323, filed on May 4, 2009, provisional application No. 61/254,638, filed on Oct. 23, 2009, provisional application No. 61/285,188, filed on Dec. 10, 2009, provisional application No. 61/077,441, filed on Jul. 1, 2008, provisional application No. 61/080,647, filed on Jul. 14, 2008, provisional application No. 61/081,685, filed on Jul. 17, 2008, provisional application No. 61/163,699, filed on Mar. 26, 2009, provisional application No. 61/427,432, filed on Dec. 27, 2010, provisional application No. 61/472,107, filed on Apr. 5, 2011.

References Cited

U.S. PATENT DOCUMENTS

(56)

1,690,812 A 11/1928 Bertels
 1,938,200 A 12/1933 Wells
 2,243,757 A 5/1941 Kohls et al.
 2,269,749 A 1/1942 Wilkie
 2,372,553 A 3/1945 Coddington
 2,437,697 A 3/1948 Kalom
 2,516,882 A 8/1950 Kalom
 2,704,064 A 5/1955 Fizzell
 2,820,281 A 1/1958 Amsen
 2,843,128 A 7/1958 Storz
 2,982,005 A 5/1961 Booth
 RE25,582 E 5/1964 Davies
 3,150,470 A 9/1964 Barron
 3,200,814 A 8/1965 Taylor et al.
 3,389,447 A 6/1968 Theobald et al.
 3,491,776 A 1/1970 Fleming
 3,495,590 A 2/1970 Zeiller
 3,528,152 A 9/1970 Funakubo et al.
 3,624,484 A 11/1971 Colyer
 3,640,280 A 2/1972 Slanker et al.
 3,651,844 A 3/1972 Barnes
 3,664,329 A 5/1972 Naylor
 3,682,162 A 8/1972 Colyer
 3,699,729 A 10/1972 Garvey et al.
 3,752,166 A 8/1973 Lyon et al.
 3,774,355 A 11/1973 Dawson et al.
 3,830,226 A 8/1974 Staub et al.
 3,835,859 A 9/1974 Roberts et al.
 3,956,858 A 5/1976 Catlin et al.
 3,957,036 A 5/1976 Normann
 3,978,862 A 9/1976 Morrison
 3,999,294 A 12/1976 Shoben
 4,015,931 A 4/1977 Thakur
 4,099,519 A 7/1978 Warren
 4,108,182 A 8/1978 Hartman et al.
 4,160,320 A 7/1979 Wikoff
 4,172,440 A 10/1979 Schneider et al.
 4,203,444 A 5/1980 Bonnell et al.
 4,207,897 A 6/1980 Lloyd et al.
 4,259,276 A 3/1981 Rawlings
 4,405,061 A 9/1983 Bergandy
 D273,806 S 5/1984 Bolesky et al.
 4,464,836 A 8/1984 Hissa
 4,502,184 A 3/1985 Karubian
 4,515,168 A 5/1985 Chester et al.
 4,518,022 A 5/1985 Valdes et al.
 4,545,374 A 10/1985 Jacobson
 4,573,448 A 3/1986 Kambin
 4,580,545 A 4/1986 Dorsten
 4,590,949 A 5/1986 Pohndorf
 4,616,660 A 10/1986 Johns
 4,621,636 A 11/1986 Fogarty
 4,625,725 A 12/1986 Davison et al.
 4,660,571 A 4/1987 Hess et al.
 4,678,459 A 7/1987 Onik et al.
 4,690,642 A 9/1987 Kyotani
 4,700,702 A 10/1987 Nilsson
 4,709,699 A 12/1987 Michael et al.
 4,741,343 A 5/1988 Bowman et al.

4,750,249 A 6/1988 Richardson
 4,794,931 A 1/1989 Yock
 4,808,157 A 2/1989 Coombs
 4,817,628 A 4/1989 Zelear et al.
 4,856,193 A 8/1989 Grachan
 4,867,155 A 9/1989 Isaacson
 4,872,452 A 10/1989 Alexson
 4,873,978 A 10/1989 Ginsburg
 4,883,460 A 11/1989 Zanetti
 4,894,063 A 1/1990 Nashe
 4,912,799 A 4/1990 Coleman, Jr.
 RE33,258 E 7/1990 Onik et al.
 4,943,295 A 7/1990 Hartlaub et al.
 4,946,462 A 8/1990 Watanabe
 4,957,117 A 9/1990 Wysham
 4,962,766 A 10/1990 Herzon
 4,973,329 A 11/1990 Park et al.
 4,990,148 A 2/1991 Worrick, III et al.
 4,994,036 A 2/1991 Biscopig et al.
 4,994,072 A 2/1991 Bhate et al.
 4,995,200 A 2/1991 Eberhart
 5,019,082 A 5/1991 Frey et al.
 5,025,787 A 6/1991 Sutherland et al.
 5,026,379 A 6/1991 Yoon
 5,026,386 A 6/1991 Michelson
 5,078,137 A 1/1992 Edell et al.
 5,089,003 A 2/1992 Fallin et al.
 5,100,424 A 3/1992 Jang et al.
 5,108,403 A 4/1992 Stern
 5,123,400 A 6/1992 Edgerton
 5,125,928 A 6/1992 Parins et al.
 5,147,364 A 9/1992 Comparetto
 5,152,749 A 10/1992 Giesy et al.
 5,161,534 A 11/1992 Berthiaume
 5,163,939 A 11/1992 Winston
 5,176,649 A 1/1993 Wakabayashi
 5,178,145 A 1/1993 Rea
 5,178,161 A 1/1993 Kovacs
 5,191,888 A 3/1993 Palmer et al.
 5,195,507 A 3/1993 Bilweis
 5,201,704 A 4/1993 Ray
 5,215,105 A 6/1993 Kizelshteyn et al.
 5,219,358 A 6/1993 Bendel et al.
 5,234,435 A 8/1993 Seagrave, Jr.
 5,242,418 A 9/1993 Weinstein
 5,250,035 A 10/1993 Smith et al.
 5,255,691 A 10/1993 Otten
 5,271,415 A 12/1993 Foerster et al.
 5,281,218 A 1/1994 Imran
 5,284,153 A 2/1994 Raymond et al.
 5,284,154 A 2/1994 Raymond et al.
 5,300,077 A 4/1994 Howell
 5,325,868 A 7/1994 Kimmelstiel
 5,341,807 A 8/1994 Nardella
 5,351,679 A 10/1994 Mayzels et al.
 5,353,784 A 10/1994 Nady-Mohamed
 5,353,789 A 10/1994 Schlobohm
 5,353,802 A 10/1994 Ollmar
 5,360,441 A 11/1994 Otten
 5,365,928 A 11/1994 Rhinehart et al.
 5,374,261 A 12/1994 Yoon
 5,383,879 A 1/1995 Phillips
 5,385,146 A 1/1995 Goldreyer
 5,387,218 A 2/1995 Meswania
 5,396,880 A 3/1995 Kagan et al.
 5,421,348 A 6/1995 Larnard
 5,423,331 A 6/1995 Wysham
 5,437,661 A 8/1995 Rieser
 5,439,464 A 8/1995 Shapiro
 5,441,044 A 8/1995 Tovey et al.
 5,441,510 A 8/1995 Simpson et al.
 5,454,815 A 10/1995 Geisser et al.
 5,456,254 A 10/1995 Pietroski et al.
 5,496,325 A 3/1996 McLees
 5,512,037 A 4/1996 Russell et al.
 5,515,848 A 5/1996 Corbett, III et al.
 5,531,749 A 7/1996 Michelson
 5,534,009 A 7/1996 Lander
 5,546,958 A 8/1996 Thorud et al.

US 8,398,641 B2

5,554,110 A	9/1996	Edwards et al.	6,099,514 A	8/2000	Sharkey et al.
5,555,892 A	9/1996	Tipton	6,102,930 A	8/2000	Simmons, Jr.
5,560,372 A	10/1996	Cory	6,106,558 A	8/2000	Picha
5,562,695 A	10/1996	Obenchain	6,113,534 A	9/2000	Koros et al.
5,571,181 A	11/1996	Li	D432,384 S	10/2000	Simons
5,582,618 A	12/1996	Chin et al.	6,132,387 A	10/2000	Gozani et al.
5,598,848 A	2/1997	Swanson et al.	6,136,014 A	10/2000	Sirimanne et al.
5,620,447 A	4/1997	Smith et al.	6,142,993 A	11/2000	Whayne et al.
5,630,426 A	5/1997	Eggers et al.	6,142,994 A	11/2000	Swanson et al.
5,634,475 A	6/1997	Wolvek	6,146,380 A	11/2000	Racz et al.
5,643,304 A	7/1997	Schechter et al.	6,152,894 A	11/2000	Kubler
5,651,373 A	7/1997	Mah	6,169,916 B1	1/2001	West
5,656,012 A	8/1997	Sienkiewicz	6,205,360 B1	3/2001	Carter
5,680,860 A	10/1997	Imran	6,214,001 B1	4/2001	Casscells et al.
5,681,324 A	10/1997	Kammerer et al.	6,214,016 B1	4/2001	Williams et al.
5,697,889 A	12/1997	Slotman et al.	6,236,892 B1	5/2001	Feler
5,709,697 A	1/1998	Ratcliff et al.	6,251,115 B1	6/2001	Williams et al.
5,725,530 A	3/1998	Popken	6,256,540 B1	7/2001	Panescu et al.
5,735,792 A	4/1998	Vanden Hoek et al.	6,259,945 B1	7/2001	Epstein et al.
5,755,732 A	5/1998	Green et al.	6,261,582 B1	7/2001	Needham et al.
5,759,159 A	6/1998	Masreliez	6,266,551 B1	7/2001	Osadchy et al.
5,762,629 A	6/1998	Kambin	6,266,558 B1	7/2001	Gozani et al.
5,766,168 A	6/1998	Mantell	6,267,760 B1	7/2001	Swanson
5,769,865 A	6/1998	Kermode et al.	6,272,367 B1	8/2001	Chance
5,775,331 A	7/1998	Raymond et al.	6,277,094 B1	8/2001	Schendel
5,779,642 A	7/1998	Nightengale	6,280,447 B1	8/2001	Marino et al.
5,788,653 A	8/1998	Lorenzo	6,292,702 B1	9/2001	King et al.
5,792,044 A	8/1998	Foley et al.	6,298,256 B1	10/2001	Meyer
5,795,308 A	8/1998	Russin	6,312,392 B1	11/2001	Herzon
5,800,350 A	9/1998	Coppleson et al.	6,324,418 B1	11/2001	Crowley et al.
5,803,902 A	9/1998	Sienkiewicz et al.	6,324,432 B1	11/2001	Rigaux et al.
5,803,904 A	9/1998	Mehdizadeh	6,325,764 B1	12/2001	Griffith et al.
5,807,263 A	9/1998	Chance	6,334,068 B1	12/2001	Hacker
5,810,744 A	9/1998	Chu et al.	6,343,226 B1	1/2002	Sunde et al.
5,813,405 A	9/1998	Montano, Jr. et al.	6,358,254 B1	3/2002	Anderson
5,824,040 A	10/1998	Cox et al.	6,360,750 B1	3/2002	Gerber et al.
5,830,151 A	11/1998	Hadzic et al.	6,364,886 B1	4/2002	Sklar
5,830,157 A	11/1998	Foote	6,368,324 B1	4/2002	Dinger et al.
5,830,188 A	11/1998	Abouleish	6,370,411 B1	4/2002	Osadchy et al.
5,833,692 A	11/1998	Cesarini et al.	6,370,435 B2	4/2002	Panescu et al.
5,836,810 A	11/1998	Asum	6,383,509 B1	5/2002	Donovan et al.
5,836,948 A	11/1998	Zucherman et al.	6,390,906 B1	5/2002	Subramanian
5,843,110 A	12/1998	Dross et al.	6,391,028 B1	5/2002	Fanton et al.
5,846,196 A	12/1998	Siekmeyer et al.	6,416,505 B1	7/2002	Fleischman et al.
5,846,244 A	12/1998	Cripe	6,423,071 B1	7/2002	Lawson
5,851,191 A	12/1998	Gozani	6,423,080 B1	7/2002	Gellman et al.
5,851,209 A	12/1998	Kummer et al.	6,425,859 B1	7/2002	Foley et al.
5,851,214 A	12/1998	Larsen et al.	6,425,887 B1	7/2002	McGuckin et al.
5,853,373 A	12/1998	Griffith et al.	6,428,486 B2	8/2002	Ritchart et al.
5,865,844 A	2/1999	Plaia et al.	6,436,101 B1	8/2002	Hamada
5,868,767 A	2/1999	Farley et al.	6,442,848 B1	9/2002	Dean
5,879,353 A	3/1999	Terry	6,446,621 B1	9/2002	Svensson
5,885,219 A	3/1999	Nightengale	6,451,335 B1	9/2002	Goldenheim et al.
5,895,417 A	4/1999	Pomeranz et al.	6,454,767 B2	9/2002	Alleyne
5,897,583 A	4/1999	Meyer et al.	6,464,682 B1	10/2002	Snoke
5,899,909 A	5/1999	Claren et al.	6,466,817 B1	10/2002	Kaula et al.
5,904,657 A	5/1999	Unsworth et al.	6,468,289 B1	10/2002	Bonutti
5,916,173 A	6/1999	Kirsner	6,470,209 B2	10/2002	Snoke
5,918,604 A	7/1999	Whelan	6,478,805 B1	11/2002	Marino et al.
5,919,190 A	7/1999	VanDusseldorp	6,487,439 B1	11/2002	Skladnev et al.
5,928,158 A	7/1999	Aristides	6,488,636 B2	12/2002	Bryan et al.
5,928,159 A	7/1999	Eggers et al.	6,491,646 B1	12/2002	Blackledge
5,941,822 A	8/1999	Skladnev et al.	6,500,128 B2	12/2002	Marino
5,961,522 A	10/1999	Mehdizadeh	6,500,189 B1	12/2002	Lang et al.
5,972,013 A	10/1999	Schmidt	6,512,958 B1	1/2003	Swoyer et al.
5,976,110 A	11/1999	Greengrass et al.	6,516,223 B2	2/2003	Hofmann
5,976,146 A	11/1999	Ogawa et al.	6,520,907 B1	2/2003	Foley et al.
6,002,964 A	12/1999	Feler et al.	6,527,786 B1	3/2003	Davis et al.
6,004,326 A	12/1999	Castro et al.	6,533,749 B1	3/2003	Mitusina et al.
6,004,330 A	12/1999	Middleman et al.	6,535,759 B1	3/2003	Epstein et al.
6,010,493 A	1/2000	Snoke	6,540,742 B1	4/2003	Thomas et al.
6,015,406 A	1/2000	Goble et al.	6,540,761 B2	4/2003	Houser
6,022,362 A	2/2000	Lee et al.	6,546,270 B1	4/2003	Goldin et al.
6,030,383 A	2/2000	Benderev	6,558,353 B2	5/2003	Zohmann
6,030,401 A	2/2000	Marino	6,558,390 B2	5/2003	Cragg
6,038,480 A	3/2000	Hrdlicka et al.	6,562,033 B2	5/2003	Shah et al.
6,048,345 A	4/2000	Berke et al.	6,564,078 B1	5/2003	Marino et al.
6,068,642 A	5/2000	Johnson et al.	6,564,079 B1	5/2003	Cory et al.
6,073,051 A	6/2000	Sharkey et al.	6,564,088 B1	5/2003	Soller et al.

US 8,398,641 B2

Page 4

6,569,160 B1	5/2003	Goldin et al.	7,010,352 B2	3/2006	Hogan
6,575,979 B1	6/2003	Cragg	7,011,635 B1	3/2006	Delay
6,579,291 B1	6/2003	Keith et al.	7,011,663 B2	3/2006	Michelson
6,584,345 B2	6/2003	Govari	7,014,616 B2	3/2006	Ferrera
6,592,559 B1	7/2003	Pakter et al.	7,033,373 B2	4/2006	de la Torre et al.
6,595,932 B2	7/2003	Ferrera	7,041,099 B2	5/2006	Thomas et al.
6,597,955 B2	7/2003	Panescu et al.	7,047,084 B2	5/2006	Erickson et al.
6,606,523 B1	8/2003	Jenkins	7,048,682 B2	5/2006	Neisz et al.
6,607,530 B1	8/2003	Carl et al.	7,050,848 B2	5/2006	Hoey et al.
6,609,018 B2	8/2003	Cory et al.	7,063,682 B1	6/2006	Whayne et al.
6,610,066 B2	8/2003	Dinger et al.	7,069,083 B2	6/2006	Finch et al.
6,620,129 B2	9/2003	Stecker et al.	7,070,556 B2	7/2006	Anderson et al.
6,622,731 B2	9/2003	Daniel et al.	7,070,596 B1	7/2006	Woloszko et al.
6,624,510 B1	9/2003	Chan et al.	7,079,883 B2	7/2006	Marino et al.
6,626,916 B1	9/2003	Yeung et al.	7,081,122 B1	7/2006	Reiley et al.
6,632,184 B1	10/2003	Truwit	7,087,053 B2	8/2006	Vanney
6,638,233 B2	10/2003	Corvi et al.	7,087,058 B2	8/2006	Cragg
RE38,335 E	11/2003	Aust et al.	7,107,104 B2	9/2006	Keravel et al.
6,648,883 B2	11/2003	Francischelli et al.	7,118,576 B2	10/2006	Gitis et al.
6,666,874 B2	12/2003	Heitzmann et al.	7,141,019 B2	11/2006	Pearlman
6,673,063 B2	1/2004	Brett	7,166,073 B2	1/2007	Ritland
6,673,068 B1	1/2004	Berube	7,166,081 B2	1/2007	McKinley
6,678,552 B2	1/2004	Pearlman	7,166,107 B2	1/2007	Anderson
6,682,535 B2	1/2004	Hoogland	7,169,107 B2	1/2007	Jersey-Willuhn et al.
6,682,536 B2	1/2004	Vardi et al.	7,172,562 B2	2/2007	McKinley
6,685,709 B2	2/2004	Sklar	7,177,677 B2	2/2007	Kaula et al.
6,699,246 B2	3/2004	Zucherman et al.	7,181,289 B2	2/2007	Pflueger et al.
6,723,049 B2	4/2004	Skladnev et al.	7,189,240 B1	3/2007	Dekel
6,726,531 B1	4/2004	Harrel	7,192,430 B2	3/2007	Truckai et al.
6,726,685 B2	4/2004	To et al.	7,198,598 B2	4/2007	Smith et al.
6,733,496 B2	5/2004	Sharkey et al.	7,198,626 B2	4/2007	Lee et al.
6,736,815 B2	5/2004	Ginn	7,207,949 B2	4/2007	Miles et al.
6,736,835 B2	5/2004	Pellegrino et al.	7,211,082 B2	5/2007	Hall et al.
6,746,451 B2	6/2004	Middleton et al.	7,214,186 B2	5/2007	Ritland
6,752,814 B2	6/2004	Gelman et al.	7,214,197 B2	5/2007	Prass
6,760,616 B2	7/2004	Hoey et al.	7,216,001 B2	5/2007	Hacker et al.
6,764,491 B2	7/2004	Frey et al.	7,223,278 B2	5/2007	Davison et al.
6,772,012 B2	8/2004	Ricart et al.	7,236,832 B2	6/2007	Hemmerling et al.
6,776,765 B2	8/2004	Soukup et al.	7,238,189 B2	7/2007	Schmieding et al.
6,786,876 B2	9/2004	Cox	7,239,911 B2	7/2007	Scholz
6,788,966 B2	9/2004	Kenan et al.	7,245,789 B2	7/2007	Bates et al.
6,790,210 B1	9/2004	Cragg et al.	7,270,658 B2	9/2007	Woloszko et al.
6,795,737 B2	9/2004	Gielen et al.	7,270,659 B2	9/2007	Ricart et al.
6,805,695 B2	10/2004	Keith et al.	7,282,033 B2	10/2007	Urmey
6,805,697 B1	10/2004	Helm et al.	7,282,061 B2	10/2007	Sharkey et al.
6,807,444 B2	10/2004	Tu et al.	7,295,881 B2	11/2007	Cohen et al.
6,830,561 B2	12/2004	Jansen et al.	7,318,823 B2	1/2008	Sharps et al.
6,830,570 B1	12/2004	Frey et al.	7,337,005 B2	2/2008	Kim et al.
6,832,111 B2	12/2004	Tu et al.	7,337,006 B2	2/2008	Kim et al.
6,845,264 B1	1/2005	Skladnev et al.	7,367,972 B2	5/2008	Francischelli et al.
6,847,849 B2	1/2005	Mamo et al.	7,383,639 B2	6/2008	Malandain
6,851,430 B2	2/2005	Tsou	7,390,330 B2	6/2008	Harp
6,865,409 B2	3/2005	Getsla et al.	7,419,487 B2	9/2008	Johnson et al.
6,872,204 B2	3/2005	Houser	7,449,019 B2	11/2008	Uchida et al.
6,875,221 B2	4/2005	Cull	7,452,351 B2	11/2008	Miller et al.
6,882,879 B2	4/2005	Rock	7,470,236 B1	12/2008	Kelleher et al.
6,884,220 B2	4/2005	Aviv et al.	7,476,226 B2	1/2009	Weikel et al.
6,890,353 B2	5/2005	Cohn et al.	7,494,473 B2	2/2009	Eggers et al.
6,895,283 B2	5/2005	Erickson et al.	7,500,977 B2	3/2009	Assell et al.
6,899,716 B2	5/2005	Cragg	7,503,920 B2	3/2009	Siegal
6,907,884 B2	6/2005	Pellegrino et al.	7,507,218 B2	3/2009	Aliski et al.
6,911,003 B2	6/2005	Anderson et al.	7,522,953 B2	4/2009	Gharib et al.
6,911,016 B2	6/2005	Balzum et al.	7,553,307 B2	6/2009	Bleich et al.
6,916,328 B2	7/2005	Brett	7,555,343 B2	6/2009	Bleich
6,923,813 B2	8/2005	Phillips et al.	7,578,819 B2	8/2009	Bleich et al.
6,929,647 B2	8/2005	Cohen	7,617,006 B2	11/2009	Metzler et al.
6,949,104 B2	9/2005	Griffis et al.	7,641,658 B2	1/2010	Shaolian et al.
6,962,587 B2	11/2005	Johnson et al.	7,648,521 B2	1/2010	Hestad
6,969,392 B2	11/2005	Gitis et al.	7,655,026 B2	2/2010	Justis et al.
6,971,986 B2	12/2005	Staskin et al.	7,666,186 B2	2/2010	Harp
6,972,199 B2	12/2005	Lebouitz et al.	7,666,209 B2	2/2010	Zucherman et al.
6,973,342 B1	12/2005	Swanson	7,738,968 B2	6/2010	Bleich
6,976,986 B2	12/2005	Berube	7,738,969 B2	6/2010	Bleich
6,991,643 B2	1/2006	Saadat	7,740,631 B2	6/2010	Bleich et al.
6,994,693 B2	2/2006	Tal	7,857,813 B2	12/2010	Schmitz et al.
6,997,934 B2	2/2006	Snow et al.	7,887,538 B2	2/2011	Bleich et al.
6,999,820 B2	2/2006	Jordan	7,918,849 B2	4/2011	Bleich et al.
7,001,333 B2	2/2006	Hamel et al.	7,938,830 B2	5/2011	Saadat et al.
7,008,431 B2	3/2006	Simonson	7,959,577 B2	6/2011	Schmitz et al.

US 8,398,641 B2

7,963,915 B2	6/2011	Bleich	2006/0058732 A1	3/2006	Harp
8,048,080 B2	11/2011	Bleich et al.	2006/0064101 A1	3/2006	Arramon
8,062,298 B2	11/2011	Schmitz et al.	2006/0079919 A1	4/2006	Harp
8,062,300 B2	11/2011	Schmitz et al.	2006/0085048 A1	4/2006	Cory et al.
2001/0014806 A1	8/2001	Ellman et al.	2006/0085049 A1	4/2006	Cory et al.
2001/0025192 A1	9/2001	Gerber et al.	2006/0089650 A1	4/2006	Nolde
2001/0039419 A1	11/2001	Francischelli et al.	2006/0089688 A1	4/2006	Panescu
2002/0022788 A1	2/2002	Corvi et al.	2006/0095028 A1	5/2006	Bleich
2002/0029060 A1	3/2002	Hogendijk	2006/0095059 A1	5/2006	Bleich et al.
2002/0106681 A1	8/2002	Wexler et al.	2006/0122458 A1	6/2006	Bleich
2002/0138091 A1	9/2002	Pflueger	2006/0122620 A1	6/2006	Kim
2002/0165590 A1	11/2002	Crowe et al.	2006/0122653 A1	6/2006	Bradley et al.
2002/0183647 A1	12/2002	Gozani et al.	2006/0122654 A1	6/2006	Bradley et al.
2003/0015203 A1	1/2003	Makower et al.	2006/0142753 A1	6/2006	Francischelli et al.
2003/0074037 A1	4/2003	Moore et al.	2006/0149278 A1	7/2006	Abdou
2003/0105503 A1	6/2003	Marino	2006/0161189 A1	7/2006	Harp
2003/0113906 A1	6/2003	Sangha et al.	2006/0173374 A1	8/2006	Neubardt et al.
2003/0130655 A1	7/2003	Woloszko	2006/0184175 A1	8/2006	Schomer et al.
2003/0130738 A1	7/2003	Hovda et al.	2006/0195107 A1	8/2006	Jones et al.
2003/0167021 A1	9/2003	Shimm	2006/0200153 A1	9/2006	Harp
2003/0187368 A1	10/2003	Safa et al.	2006/0200154 A1	9/2006	Harp
2003/0188749 A1	10/2003	Nichols et al.	2006/0200155 A1	9/2006	Harp
2003/0212400 A1	11/2003	Bloemer et al.	2006/0200219 A1	9/2006	Thrope et al.
2003/0225412 A1	12/2003	Shiraishi	2006/0206115 A1	9/2006	Schomer et al.
2003/0225415 A1	12/2003	Richard	2006/0206117 A1	9/2006	Harp
2004/0006379 A1	1/2004	Brett	2006/0206118 A1	9/2006	Kim et al.
2004/0006391 A1	1/2004	Reiley	2006/0206178 A1	9/2006	Kim
2004/0019359 A1	1/2004	Worley et al.	2006/0224060 A1	10/2006	Garell et al.
2004/0030330 A1	2/2004	Brassell et al.	2006/0224078 A1	10/2006	Hoey et al.
2004/0049208 A1	3/2004	Hill et al.	2006/0235451 A1	10/2006	Schomer et al.
2004/0059260 A1	3/2004	Truwit	2006/0235452 A1	10/2006	Schomer et al.
2004/0064058 A1	4/2004	McKay	2006/0264952 A1	11/2006	Nelson et al.
2004/0097927 A1	5/2004	Yeung et al.	2006/0264994 A1	11/2006	Schomer et al.
2004/0098074 A1	5/2004	Erickson et al.	2006/0271080 A1	11/2006	Suddaby
2004/0106940 A1	6/2004	Shaolian et al.	2006/0276720 A1	12/2006	McGinnis et al.
2004/0111084 A1	6/2004	Brett	2006/0276802 A1	12/2006	Vresilovic et al.
2004/0122433 A1	6/2004	Loubens et al.	2006/0276836 A1	12/2006	Bergin et al.
2004/0122482 A1	6/2004	Tung et al.	2007/0010717 A1	1/2007	Cragg
2004/0127893 A1	7/2004	Hovda	2007/0016097 A1	1/2007	Farquhar et al.
2004/0143165 A1	7/2004	Alleyne	2007/0016185 A1	1/2007	Tullis et al.
2004/0143280 A1	7/2004	Suddaby	2007/0027464 A1	2/2007	Way et al.
2004/0162609 A1	8/2004	Hossainy et al.	2007/0027514 A1	2/2007	Gerber
2004/0167444 A1	8/2004	Laroya et al.	2007/0049962 A1	3/2007	Marino et al.
2004/0167553 A1	8/2004	Simpson et al.	2007/0055215 A1	3/2007	Tran et al.
2004/0181150 A1	9/2004	Evans et al.	2007/0055262 A1	3/2007	Tomita et al.
2004/0199084 A1	10/2004	Kelleher et al.	2007/0055263 A1	3/2007	Way et al.
2004/0199159 A1	10/2004	Lee et al.	2007/0073356 A1	3/2007	Rooney et al.
2004/0220576 A1	11/2004	Sklar	2007/0106219 A1	5/2007	Grabinsky
2004/0225233 A1	11/2004	Frankowski et al.	2007/0123766 A1	5/2007	Whalen, III et al.
2004/0260358 A1	12/2004	Vaughan et al.	2007/0123890 A1	5/2007	Way et al.
2005/0027199 A1	2/2005	Clarke	2007/0162044 A1	7/2007	Marino
2005/0033393 A1	2/2005	Daglow	2007/0162061 A1	7/2007	Way et al.
2005/0049592 A1	3/2005	Keith et al.	2007/0162062 A1	7/2007	Norton et al.
2005/0149035 A1	7/2005	Pimenta et al.	2007/0166345 A1	7/2007	Pavcnik et al.
2005/0171587 A1	8/2005	Daglow et al.	2007/0198019 A1	8/2007	Schomer et al.
2005/0182454 A1	8/2005	Gharib et al.	2007/0213583 A1	9/2007	Kim et al.
2005/0187537 A1	8/2005	Loeb et al.	2007/0213584 A1	9/2007	Kim et al.
2005/0197661 A1	9/2005	Carrison et al.	2007/0213733 A1	9/2007	Bleich et al.
2005/0203599 A1	9/2005	Garabedian et al.	2007/0213734 A1	9/2007	Bleich et al.
2005/0209610 A1	9/2005	Carrison	2007/0213795 A1	9/2007	Bradley et al.
2005/0209617 A1	9/2005	Koven et al.	2007/0255162 A1	11/2007	Abboud et al.
2005/0209622 A1	9/2005	Carrison	2007/0255369 A1	11/2007	Bonde et al.
2005/0216023 A1	9/2005	Aram et al.	2007/0270795 A1	11/2007	Francischelli et al.
2005/0222598 A1	10/2005	Ho et al.	2007/0270865 A1	11/2007	Arnin et al.
2005/0222647 A1	10/2005	Wahlstrand et al.	2007/0276286 A1	11/2007	Miller
2005/0256423 A1	11/2005	Kirsner	2007/0276390 A1	11/2007	Solsberg et al.
2005/0261692 A1	11/2005	Carrison et al.	2007/0282217 A1	12/2007	McGinnis et al.
2005/0277942 A1	12/2005	Kullas et al.	2007/0293782 A1	12/2007	Marino
2005/0283148 A1	12/2005	Janssen et al.	2007/0299403 A1	12/2007	Crowe et al.
2005/0283204 A1	12/2005	Buhlmann et al.	2007/0299459 A1	12/2007	Way et al.
2006/0004369 A1	1/2006	Patel et al.	2008/0033465 A1	2/2008	Schmitz et al.
2006/0015035 A1	1/2006	Rock	2008/0051812 A1	2/2008	Schmitz et al.
2006/0025702 A1	2/2006	Sterrantino et al.	2008/0058820 A1	3/2008	Harp
2006/0025703 A1	2/2006	Miles et al.	2008/0058874 A1	3/2008	Westlund et al.
2006/0025797 A1	2/2006	Lock et al.	2008/0064945 A1	3/2008	Marino et al.
2006/0030854 A1	2/2006	Haines	2008/0064976 A1	3/2008	Kelleher et al.
2006/0036211 A1	2/2006	Solsberg et al.	2008/0064977 A1	3/2008	Kelleher et al.
2006/0036271 A1	2/2006	Schomer et al.	2008/0065178 A1	3/2008	Kelleher et al.
2006/0036272 A1	2/2006	Solsberg et al.	2008/0071191 A1	3/2008	Kelleher et al.

2008/0086034	A1	4/2008	Schmitz et al.	EP	1611851	A1	1/2006
2008/0091227	A1	4/2008	Schmitz et al.	EP	1006885	B1	9/2006
2008/0097465	A1	4/2008	Rollins et al.	FR	2706309		12/1994
2008/0103504	A1	5/2008	Schmitz et al.	JP	2960140	B2	10/1999
2008/0119711	A1	5/2008	Nikumbe et al.	JP	23116868		4/2003
2008/0125621	A1	5/2008	Gellman et al.	JP	24065380	A2	3/2004
2008/0125709	A1	5/2008	Chang et al.	RU	2107459		3/1998
2008/0140153	A1	6/2008	Burdulis	WO	WO92/22259	A2	12/1992
2008/0140169	A1	6/2008	Imran	WO	WO-96/22057		7/1996
2008/0146867	A1	6/2008	Gellman et al.	WO	WO97/14362	A1	4/1997
2008/0147084	A1	6/2008	Bleich et al.	WO	WO-97/34536	A2	9/1997
2008/0161809	A1	7/2008	Schmitz et al.	WO	WO-99/18866	A1	4/1999
2008/0161810	A1	7/2008	Melkent	WO	WO-99/21500	A1	5/1999
2008/0197024	A1	8/2008	Simpson et al.	WO	WO-00/67651	A1	11/2000
2008/0200912	A1	8/2008	Long et al.	WO	WO-01/08571	A1	2/2001
2008/0221383	A1	9/2008	Way et al.	WO	WO-01/62168	A2	8/2001
2008/0221586	A1	9/2008	Garcia-Bengochea et al.	WO	WO-02/07901	A1	1/2002
2008/0255439	A1	10/2008	Tang et al.	WO	WO-02/34120	A2	5/2002
2008/0275458	A1	11/2008	Bleich et al.	WO	WO-02/076311	A2	10/2002
2008/0288005	A1	11/2008	Jackson	WO	WO-03/026482	A2	4/2003
2008/0312660	A1	12/2008	Bleich et al.	WO	WO-03/066147	A1	8/2003
2008/0319459	A1	12/2008	Al-najjar	WO	WO-2004/002331	A1	1/2004
2009/0018507	A1	1/2009	Schmitz et al.	WO	WO-2004/028351	A2	4/2004
2009/0018610	A1	1/2009	Gharib et al.	WO	WO-2004/04272	A1	5/2004
2009/0036936	A1	2/2009	Solsberg et al.	WO	WO-2004/056267	A1	7/2004
2009/0054804	A1	2/2009	Gharib et al.	WO	WO-2004/078066	A2	9/2004
2009/0054936	A1	2/2009	Eggen et al.	WO	WO-2004/080316	A1	9/2004
2009/0054941	A1	2/2009	Eggen et al.	WO	WO-2004/096080	A2	11/2004
2009/0062871	A1	3/2009	Chin et al.	WO	WO-2005/009300	A1	2/2005
2009/0062872	A1	3/2009	Chin et al.	WO	WO-2005/057467	A2	6/2005
2009/0082763	A1	3/2009	Quick et al.	WO	WO-2005/077252	A1	8/2005
2009/0105604	A1	4/2009	Bertagnoli et al.	WO	WO-2005/089433	A2	9/2005
2009/0105788	A1	4/2009	Bartol et al.	WO	WO-2006/009705	A2	1/2006
2009/0118709	A1	5/2009	Sand et al.	WO	WO-2006/015302	A1	2/2006
2009/0124934	A1	5/2009	Rabbitte et al.	WO	WO-2006/017507	A2	2/2006
2009/0138056	A1	5/2009	Anderson et al.	WO	WO-2006/039279	A2	4/2006
2009/0143807	A1	6/2009	Sand	WO	WO-2006/042206	A2	4/2006
2009/0143829	A1	6/2009	Shluzas	WO	WO-2006/044727	A2	4/2006
2009/0149865	A1	6/2009	Schmitz et al.	WO	WO-2006/047598	A1	5/2006
2009/0171381	A1	7/2009	Schmitz et al.	WO	WO-2006/056195	A2	6/2006
2009/0177112	A1	7/2009	Gharib et al.	WO	WO-2006/058079	A3	6/2006
2009/0177144	A1	7/2009	Masmanidis et al.	WO	WO-2006/062555	A2	6/2006
2009/0177241	A1	7/2009	Bleich et al.	WO	WO-2006/086241	A2	8/2006
2009/0182382	A1	7/2009	Justis et al.	WO	WO-2006/099285	A2	9/2006
2009/0192403	A1	7/2009	Gharib et al.	WO	WO-2006/102085	A2	9/2006
2009/0204016	A1	8/2009	Gharib et al.	WO	WO-2007/008709	A2	1/2007
2009/0204119	A1	8/2009	Bleich et al.	WO	WO-2007/021588	A1	2/2007
2009/0209879	A1	8/2009	Kaula et al.	WO	WO-2007/022194	A2	2/2007
2009/0216284	A1	8/2009	Chin et al.	WO	WO-2007/059343	A2	2/2007
2009/0299166	A1	12/2009	Nishida	WO	WO-2007/067632	A2	6/2007
2010/0004654	A1	1/2010	Schmitz et al.	WO	WO-2008/008898	A2	1/2008
2010/0010334	A1	1/2010	Bleich et al.	WO	WO-2008/157513	A1	12/2008
2010/0057087	A1	3/2010	Cha	WO	WO-2009/012265	A2	1/2009
2010/0094231	A1	4/2010	Bleich et al.	WO	WO-2009/018220	A1	2/2009
2010/0274250	A1	10/2010	Wallace et al.	WO	WO-2009/021116	A2	2/2009
2010/0331883	A1	12/2010	Schmitz et al.	WO	WO-2009/036156	A1	3/2009
2010/0331900	A1	12/2010	Garabedian et al.	WO	WO-2009/046046	A1	4/2009
2011/0004207	A1	1/2011	Wallace et al.	WO	WO-2009/058566	A1	5/2009
2011/0046613	A1	2/2011	Schmitz et al.	WO	WO-2009/151926	A2	12/2009
2011/0060314	A1	3/2011	Wallace et al.	WO	WO-2010/014538		4/2010
2011/0112539	A1	5/2011	Wallace et al.				
2011/0160731	A1	6/2011	Bleich et al.				
2011/0160772	A1	6/2011	Arcenio et al.				
2011/0190772	A1	8/2011	Saadat				
2011/0196257	A1	8/2011	Schmitz et al.				
2011/0224709	A1	9/2011	Bleich				
2011/0224710	A1	9/2011	Bleich				
2012/0016368	A1	1/2012	Bleich et al.				
2012/0078255	A1	3/2012	Bleich et al.				
2012/0184809	A1	7/2012	Bleich et al.				
2012/0191003	A1	7/2012	Garabedian et al.				
2012/0239041	A1	9/2012	Bleich et al.				

FOREIGN PATENT DOCUMENTS

EP	359883	A1	3/1990
EP	1304080	A2	4/2003
EP	1340467	A2	9/2003
EP	1207794	B1	5/2004
EP	1315463	B1	5/2005

OTHER PUBLICATIONS

Schmitz et al.; U.S. Appl. No. 13/232,882 entitled "Tissue Modification Devices," filed Sep. 14, 2011.

Schmitz et al.; U.S. Appl. No. 13/267,683 entitled "Flexible Tissue Removal Devices and Methods," filed Oct. 6, 2011.

Sun et al.; U.S. Appl. No. 13/340,363 entitled "Flexible Neural Localization Devices and Methods," filed Dec. 29, 2011.

Wallace et al.; U.S. Appl. No. 13/338,103 entitled "Tissue Modification Devices and Methods," filed Dec. 27, 2011.

Wallace et al.; U.S. Appl. No. 13/338,134 entitled "Surgical Tools for Treatment of Spinal Stenosis," Dec. 27, 2011.

US Surgical Kerrison Spinal Rongeur K943116 [online] Retrieved from the internet: <URL. <http://www.ussurg.com/uss/index.html>> Jul. 27, 1994.

Edwards et al, "T-Saw Laminoplasty for the Management of Cervical Spondylotic Myelopathy," SPINE, Lippincott Williams & Wilkins, Inc., 2000, vol. 25 (14): 1788-1794, Jan. 1, 2000.

- Honl et al, "The Use of Water-Jetting Technology in Prostheses Revision Surgery—First Results of Parameter Studies on Bone and Bone Cement," *J. Biomed Mater Res (Applied Biomaterials)*, John Wiley & Sons, Inc. 2000, 53, 6:781-790. Jan. 1, 2000.
- Jun, Byung-Yoon, "Posterior Lumbar Interbody Fusion With Restoration of Lamina and Facet Fusion," *SPINE*, Lippincott Williams & Wilkins, Inc., 2000. vol. 25 No. 8, 917-922. Jan. 1, 2000.
- Abdel-Wanis et al., "Tumor growth potential after tumoral and instrumental contamination: an in-vivo comparative study of T-saw, Gigli saw, and scalpel," *Journal of orthopaedic science*, 2001, vol. 6, 424-429. Jan. 1, 2001.
- Hara et al., "En Bloc Laminoplasty Performed with Threadwire Saw: Technical Note," *Neurosurgery*, Jan. 2001, vol. 48, No. 1, pp. 235-239. Jan. 1, 2001.
- Hata et al, "A less invasive surgery for rotator cuff tear; Mini-open repair," *Journal of Shoulder and Elbow Surgery*, 2001, vol. 10 No. 1, 11-16. Jan. 1, 2001.
- Sen, Cengiz, Tibia proksimalinde Gigli testeresi ile yapilan parkutan osteotominin guvenilirliigi Kadavra calismasi, *Acta orthopaedica et traumatologica turcica*, 2002, vol. 36, 136-140; (In Russian w/ Eng Summary). Jan. 1, 2002.
- Shiraishi T., "A new technique for exposure of the cervical spine laminae." *Journal of neurosurgery Spine*, 2002, vol. 96(1). vol. 96(1). 122-126. Jan. 1, 2002.
- Shiraishi T., Skip laminectomy—a new treatment for cervical spondylotic myelopathy, preserving bilateral muscular attachments to the spinous processes: a preliminary report, *Spine*, 2002, vol. 2(2), 108-115. Jan. 1, 2002.
- Tomita et al., "The Use of the T-Saw for Expansive Midline laminoplasty in the Treatment of Cervical Myelopathy," *Orthopedics and Traumatology*, No. 3, pp. 169-178, 2002. Jan. 1, 2002.
- Martin-Benloch et al., "Expansive Laminoplasty as a Method for Managing Cervical Multilevel Spondylotic Myelopathy," *Spine*, Lippincott Williams & Wilkins, Inc., 2003, vol. 28 No. 7, 680-684. Jan. 1, 2003.
- Miyamoto et al., "Kyphectomy Using a Surgical Threadwire (T-saw) for Kyphotic Deformity in a Child With Myelomeningocele," *SPINE*, Lippincott Williams & Wilkins, Inc., 2003, vol. 28 No. 10, E187-E190. Jan. 1, 2003.
- Shiraishi et al., "Results of Skip Laminectomy—Minimum 2-Year Follow-up Study Compared With Open-Door Laminoplasty," *Spine*, Lippincott Williams & Wilkins, Inc., 2003, vol. 28 No. 24, 2667-2672, Jan. 1, 2003.
- Takada et al., "Unusual Metastasis to the Cauda Equina From Renal Cell Carcinoma," *SPINE*, Lippincott Williams & Wilkins, Inc., 2003, vol. 28 No. 6, E114-E117. Jan. 1, 2003.
- Eralp et al., "A comparison of two osteotomy techniques for tibial lengthening," *Archives of orthopaedic and trauma surgery*, 2004, vol. 124:298-300. Jan. 1, 2004.
- Skippen et al., "The Chain Saw—A Scottish Invention," *Scottish Medical Journal*, 2004, vol. 49(2), 72-75. Jan. 1, 2004.
- Bohinski et al., "Novel use of a threadwire saw for high sacral amputation," *Journal of neurosurgery: Spine*, 2005, vol. 3, 71-78. Jan. 1, 2005.
- Nakagiri et al., "Thoracoscopic Rib Resection Using a Gigli Saw," *The Annals of Thoracic Surgery*, 2005. vol. 80, 755-756, Jan. 1, 2005.
- Osaka et al., "Clinical significance of a wide excision policy for sacrococcygeal chordoma," *J Cancer Res Clin Oncol*, 2005, Total pp. 6. Jan. 1, 2005.
- Fessler Richard G, "Minimally Invasive Microendoscopic Decompressive Laminotomy for Lumbar Stenosis," *American Association of Neurological Surgeons*, 2006. Online CME course, [Retrieved on Jun. 29, 2006 from the internet http://www.aans.amedtrain.com/lumbar_ste Jan. 1, 2006.
- Park et al, "Cases of the Excision of Carious Joints," *John Scrymgeour*, Glasgow, 1806, Total pp. 6. Jan. 1, 1806.
- Pancoast, Joseph, "A Treatise on Operative Surgery," *Carey and Hart*, Philadelphia, 1844 Total pp. 11. Jan. 1, 1844.
- Truax, Charles, "The Mechanics of Surgery," *Chicago, IL*; 1899, Total pp. 3, Jan. 1, 1899.
- Burrows, Harold, "Surgical instruments and applicances used in operations," *Faber and Faber*, London, 1937, total pp. 4. Jan. 1, 1937.
- Wilkins, Robert H, "Neurosurgical Classics," *Johnson Reprint Corporation*, New York, 1965, 377-382. Jan. 1, 1965.
- Dammann, Gordon, *Pictorial Encyclopedia of Civil War Medical Instruments and Equipment*, Pictorial Histories Publishing Company, Missoula, Montana, 1983, Total pp. 2, Jan. 1, 1983.
- Barer Malvin, "Instrument to Enhance Passage of the Gigli Saw," *Journal of Pediatric Orthopedics*, Raven Press, New York, 1984, 4:762-763, Jan. 1, 1984.
- Paley et al., "Percutaneous Osteotomies," *Orthopedic Clinics of North America*, 1991, vol. 22, No. 4, 613-624, Jan. 1, 1991.
- Paktiss et al., "Afghan Percutaneous Osteotomy," *Journal of Pediatric Orthopaedics*, Raven Press Ltd, New York, 1993, vol. 13, No. 4, 531-533, Jan. 1, 1993.
- Peltier, Leonard *Orthopedics: A History and Iconography*, Norman Publishing, San Francisco, 1993, Total pp. 3, Jan. 1, 1993.
- Rutkow, Ira, "Surgery an Illustrated History," *Mosby—Year Book, Inc.*, St. Louis, 1993, Total pp. 4, Jan. 1, 1993.
- Goel, Atul, "Neurosurgical forum, Supraorbital Craniotomy," *Journal of Neurosurgery*, 1994, vol. 81, 642-643, Jan. 1, 1994.
- Tomita et al., "Total en bloc spondylectomy and circumspinal decompression for solitary spinal metastasis," *Paraplegia*, 1994, 32:36-46. Jan. 1, 1994.
- Tomita K. et al., "Total en bloc spondylectomy for solitary spinal, metastases," *International Orthopaedics (SICOT)*, 1994: 18: 291-298. Jan. 1, 1994.
- Brunori et al., "Celebrating the centennial (1894-1994): Leonardo Gigli and his wire saw," *J. Neurosurg*, 1995, 82:1086-1090. Jan. 1, 1995.
- Tomita et al., "The Threadwire Saw; a New Device for Cutting Bone," *The Journal of Bone and Joint Surgery*, 1996, vol. 76, 1915-1917, Jan. 1, 1996.
- Baumgart et al., "Indikation and Technik der Knochendurchtrennung," *Der Chirurg*, 1998, vol. 69:1186-1196. (in German with Eng Summary). Jan. 1, 1998.
- Stevens et al., "Calvarial Bone Graft Harvest Using the Gigli Saw," *Journal of Oral and Maxillofacial Surgery*, 1998, vol. 56, 798-799. Jan. 1, 1998.
- Tomita et al., "Expansive Midline T-Saw Laminoplasty (Modified Spinour Process-Splitting) for the Management of Cervical Myelopathy," *SPINE*, Lippincott Williams & Wilkins, Inc, 1998, 23(1), 32-37, Jan. 1, 1998.
- Fujita et al., "Chordoma in the Cervical Spine Managed with En Bloc Excision," *SPINE*, Lippincott Williams & Wilkins, Inc., 1999, 24 (17), 1848-1851, Jan. 1, 1999.
- Gore Smoother User Manual, *W. L. Gore & Associates, Inc.* Flagstaff, AZ, Dec. 1999, Total pp. 3. Jan. 1, 1999.
- Kawahara et al., "Recapping T-Saw Laminoplasty for Spinal Cord Tumors," *SPINE*, 1999, vol. 24 No. 13, pp. 1363-1370 Jan. 1, 1999.
- Peavy et al., "Companson of Cortical Bone Ablations by Using Infrared Laser Wavelengths 2.9 to 9.2 μ m," *Lasers in Surgery and Medicine*, 1999, vol. 26, 421-434. Jan. 1, 1999.
- Zeppelin Laminectomy Rongeur K901372, [online] Retrieved from the internet <URL: <http://www.zeppelin-medical.com/download/instruments.pdf>>. Oct. 24, 2006.
- Reckling Frederick, "Modifed Stethoscope Earpiece Makes Excellent Gigli Saw Guide," *J Bone and Joint Surgery Am.* Dec. 1972, 54-A-(8), 1787-1788, Dec. 1, 1972.
- Ellman Int. Disc-FX System Accessories K052241 [online] Retrieved from the Internet: <URL: <http://www.ellman.com/medical/>>. Feb. 27, 2006.
- Bartol et al., "Arthoroscopic Microscopic Discectomy in Awake Patients: The Effectiveness of Local/Neurolept Anaesthetic," *Canadian Spine Society Meeting*, Vernon BC, Canada, Mar. 2002.
- Bartol et al., "Use of Neve Stimulator to Localise the Spinal Nerce Root During Arthoroscopic Discectomy Procedures," *Canadian Spine Society Meeting*, Vernon BC, Canada. Mar. 2002.
- Ohta et al., "Superimposed Mechanomyographic Response at Different Contraction intensity in Medial Gastrocnemius and Soleus Muscles," *International Journal of Sport and Health Science*, vol. 5, 63-70, 2007.

Schwieger et al., "Abrasive Water Jet Cutting as a New Procedure for Cutting Cancellous Bone—In Vitro Testing in Comparison with the Oscillating Saw" Wiley Interscience. www.interscience.wiley.com, Sep. 20, 2004, 223-228. Sep. 20, 2004.

Moped Bone-Cutting tool. Product brochure. Total pp. 4 First accessed Dec. 15, 2005.

Codman Laminectomy Shaver (a Johnson & Johnson company www.codman.com) catalogue, pp. 416-431, [online] Retrieved

from the internet: <URL: http://www.codman.com/PDFs/Catalog_04_R.pdf>. First accessed Oct. 24, 2006.

Integra Ruggles TM Kerrison Rongeurs [online] Retrieved from the internet: <URL: <http://www.integra-is.com/products!?product=22>>. First accessed Oct. 24, 2006.

Herkowitz, , "The Cervical Spine Surgery Atlas", *Herkowitz, "The Cervical Spine Surgery Atlas"*, 2004, 2nd Edition Jan. 1, 2004 , 203-206, 208.

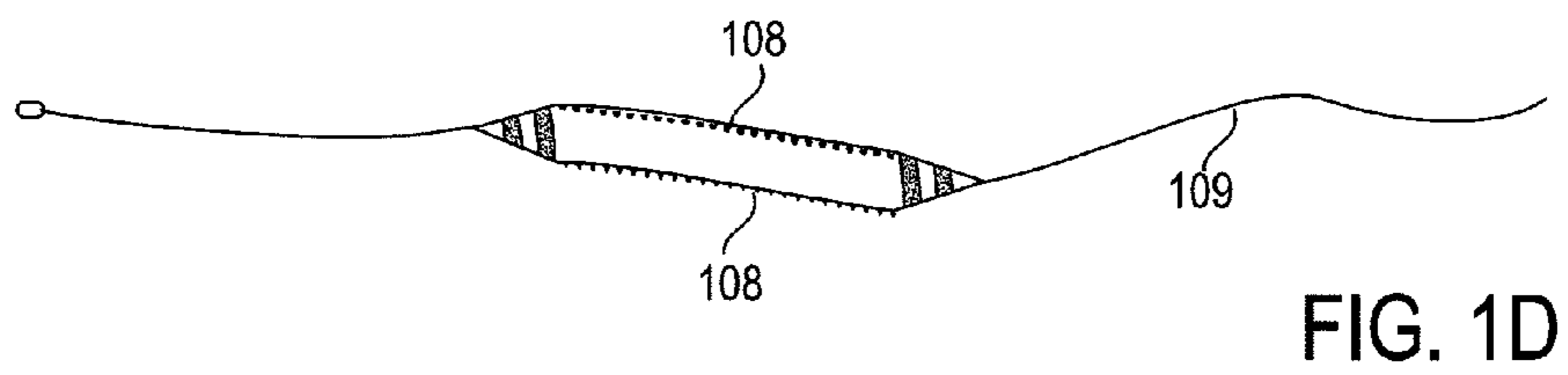
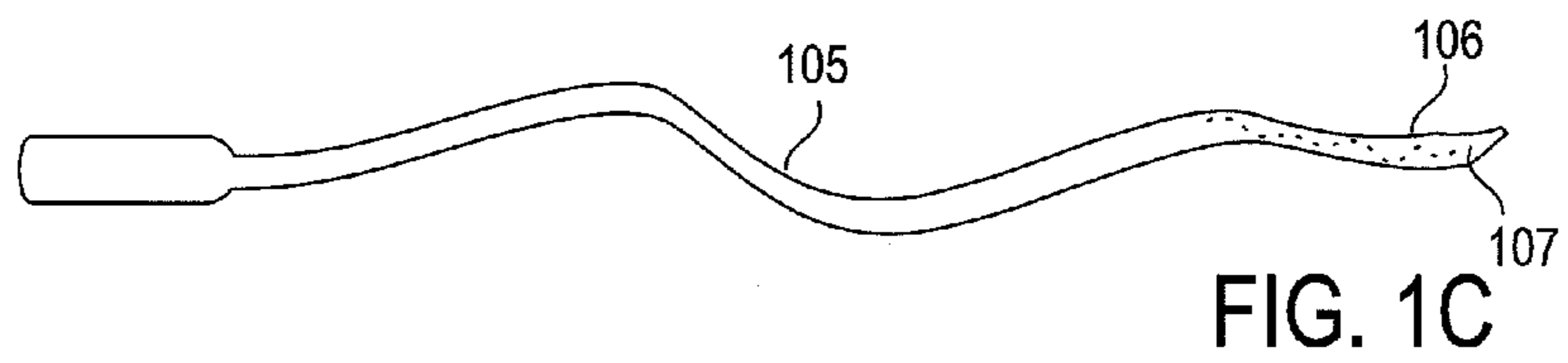
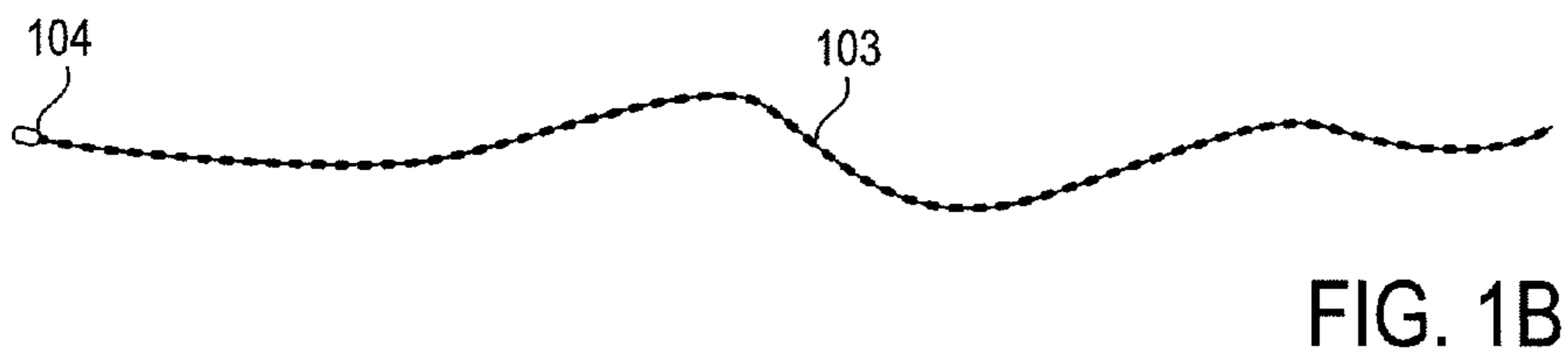
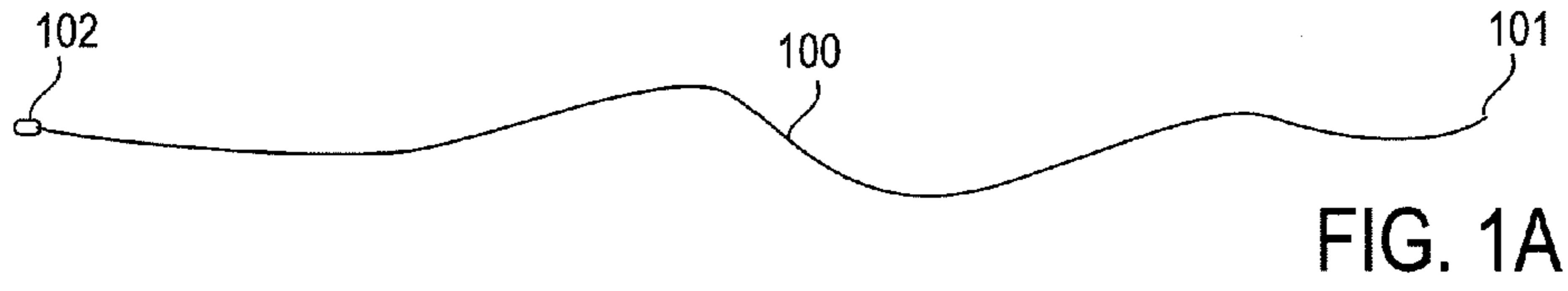

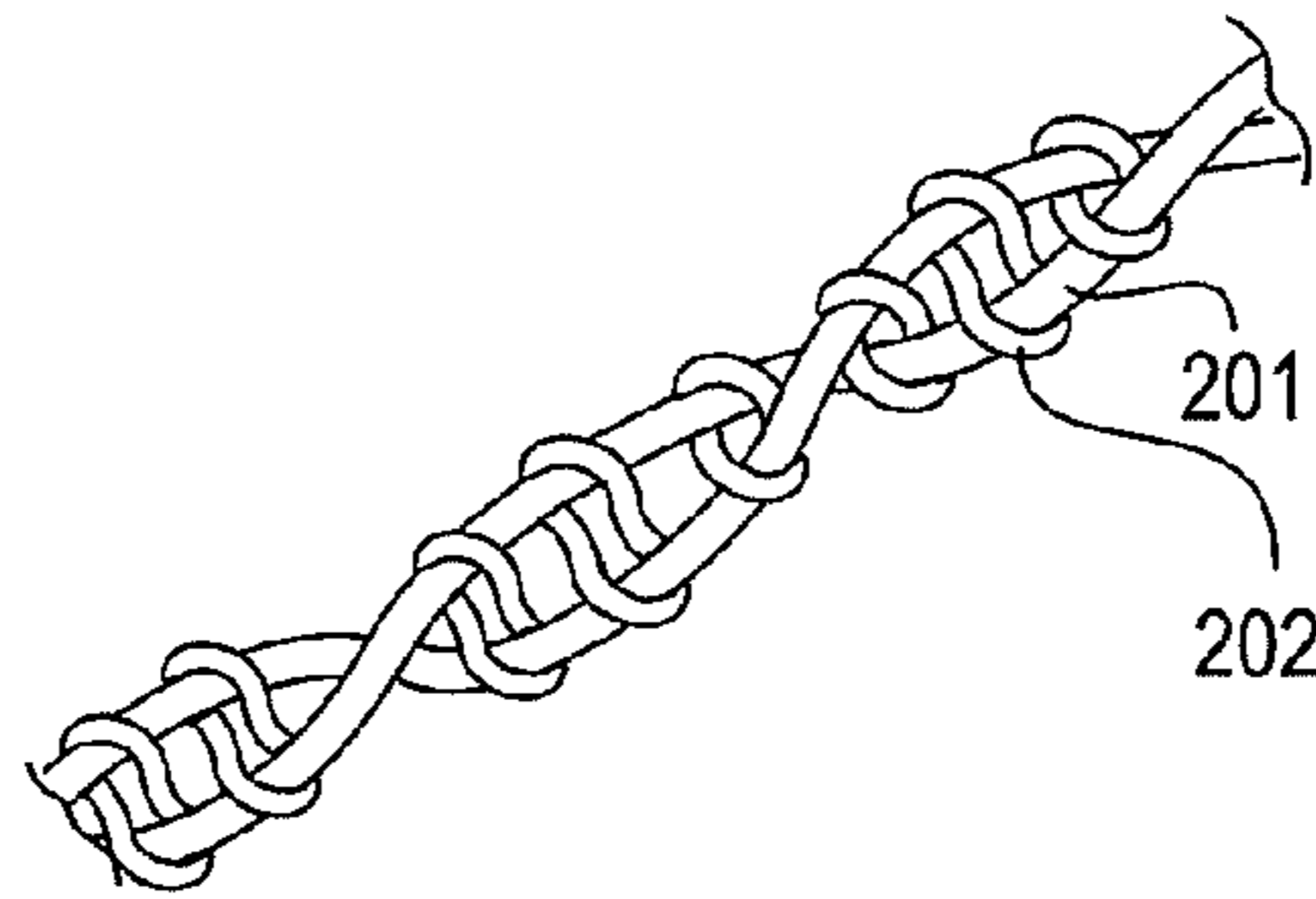

FIG. 2

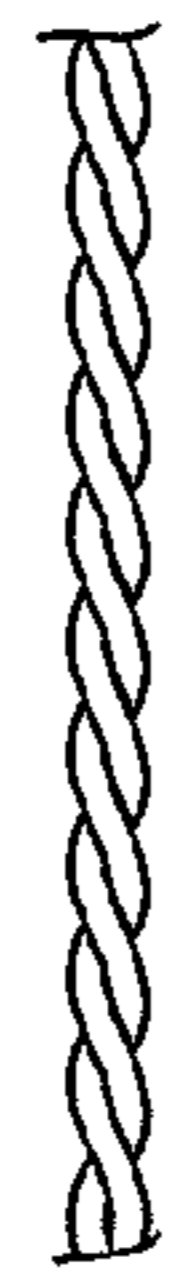

FIG. 3A

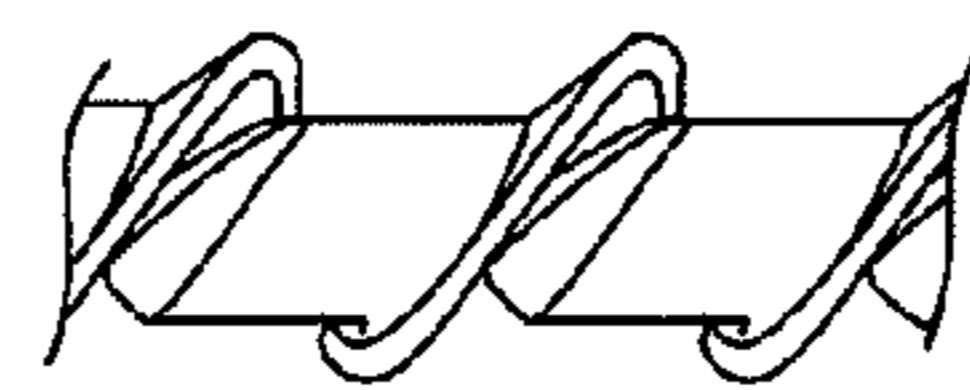

FIG. 3B

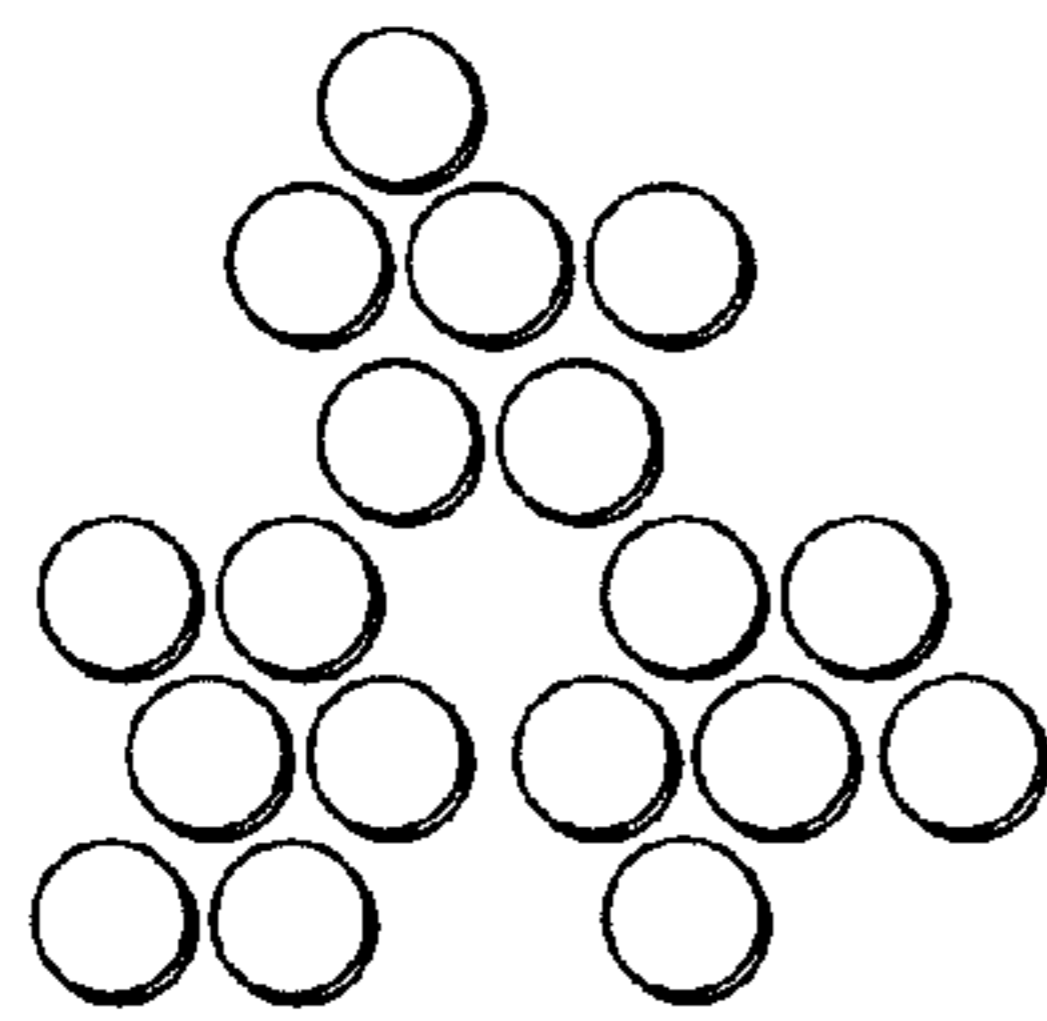

FIG. 3C

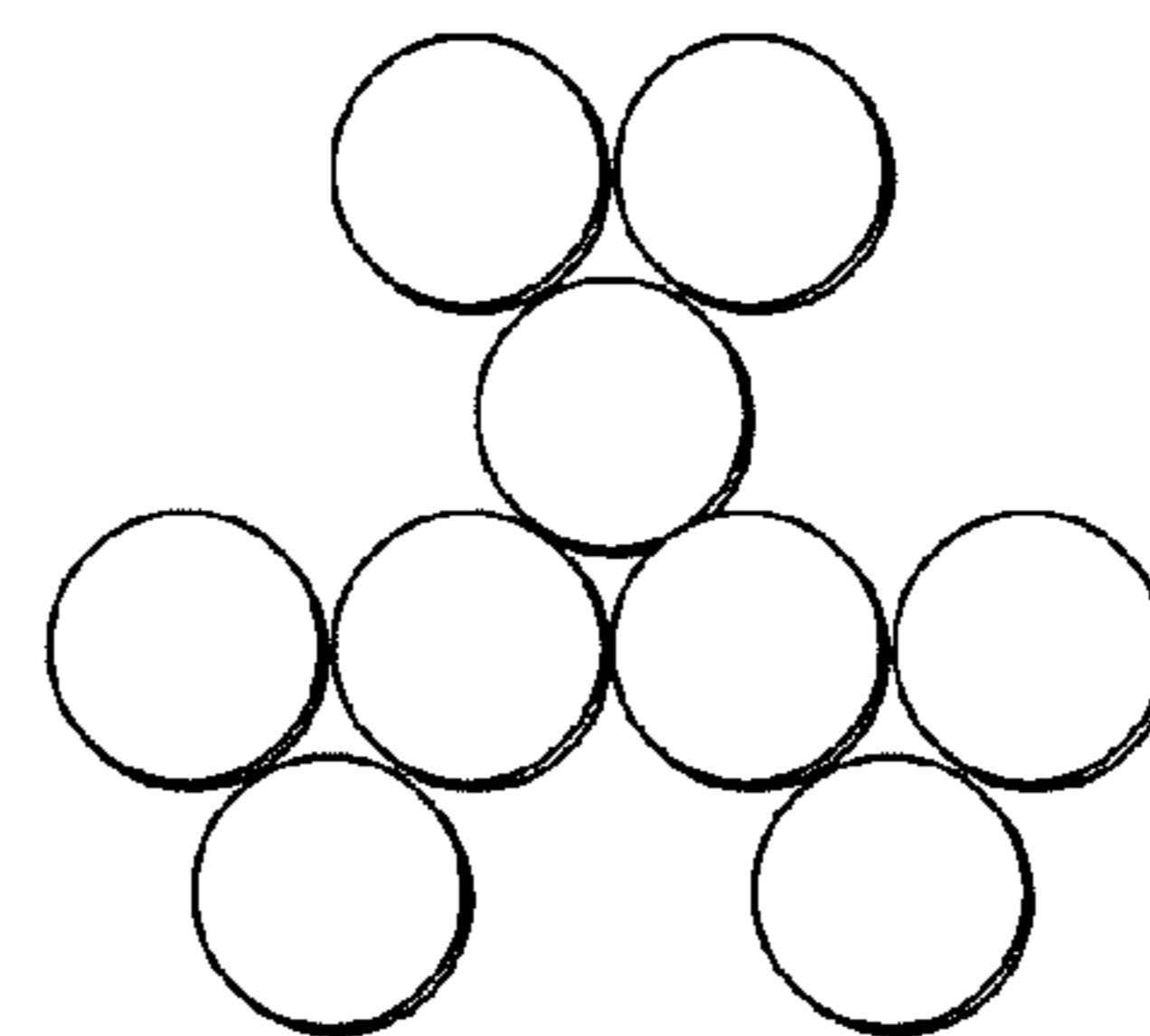

FIG. 3D

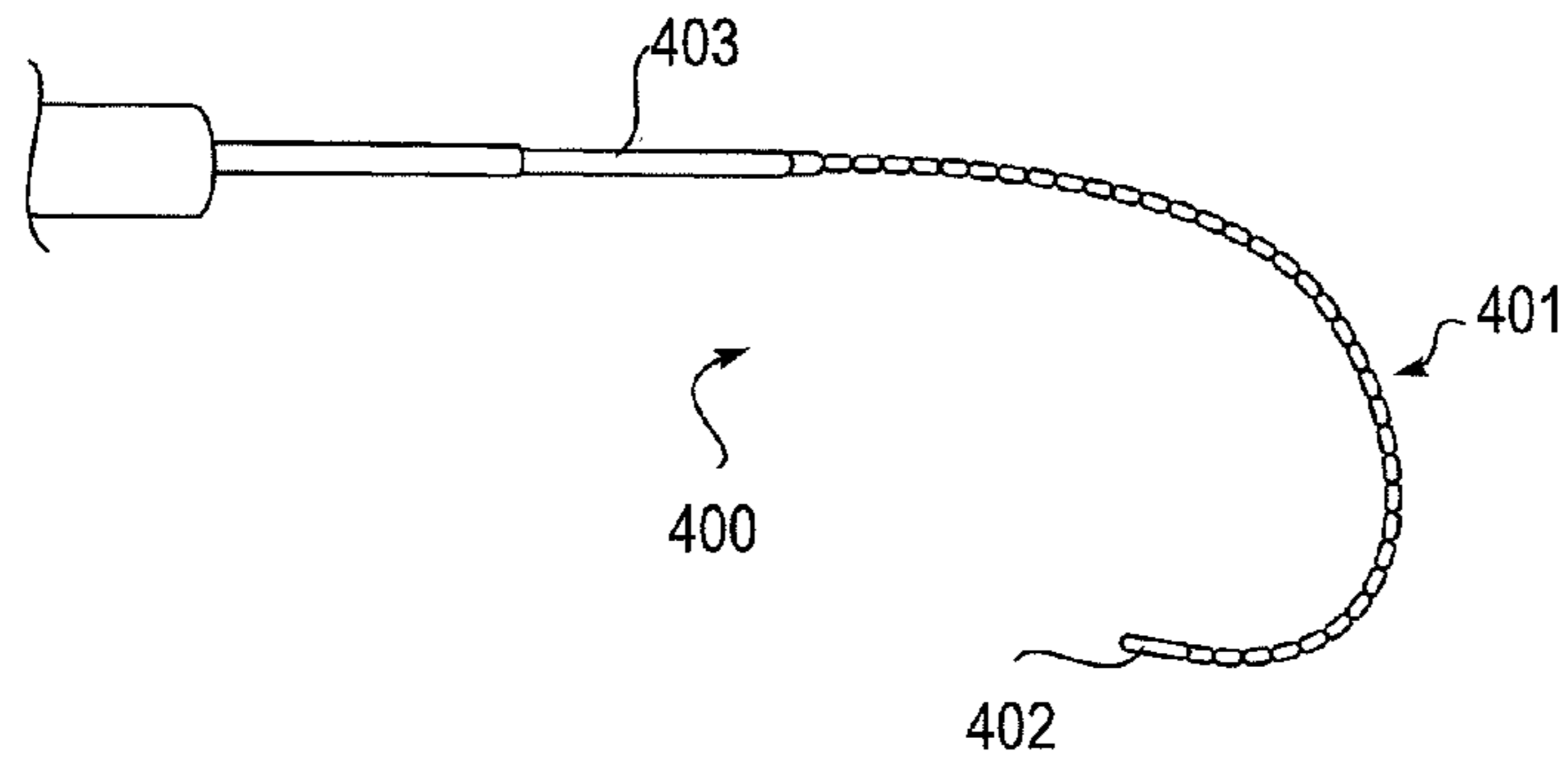

FIG. 4

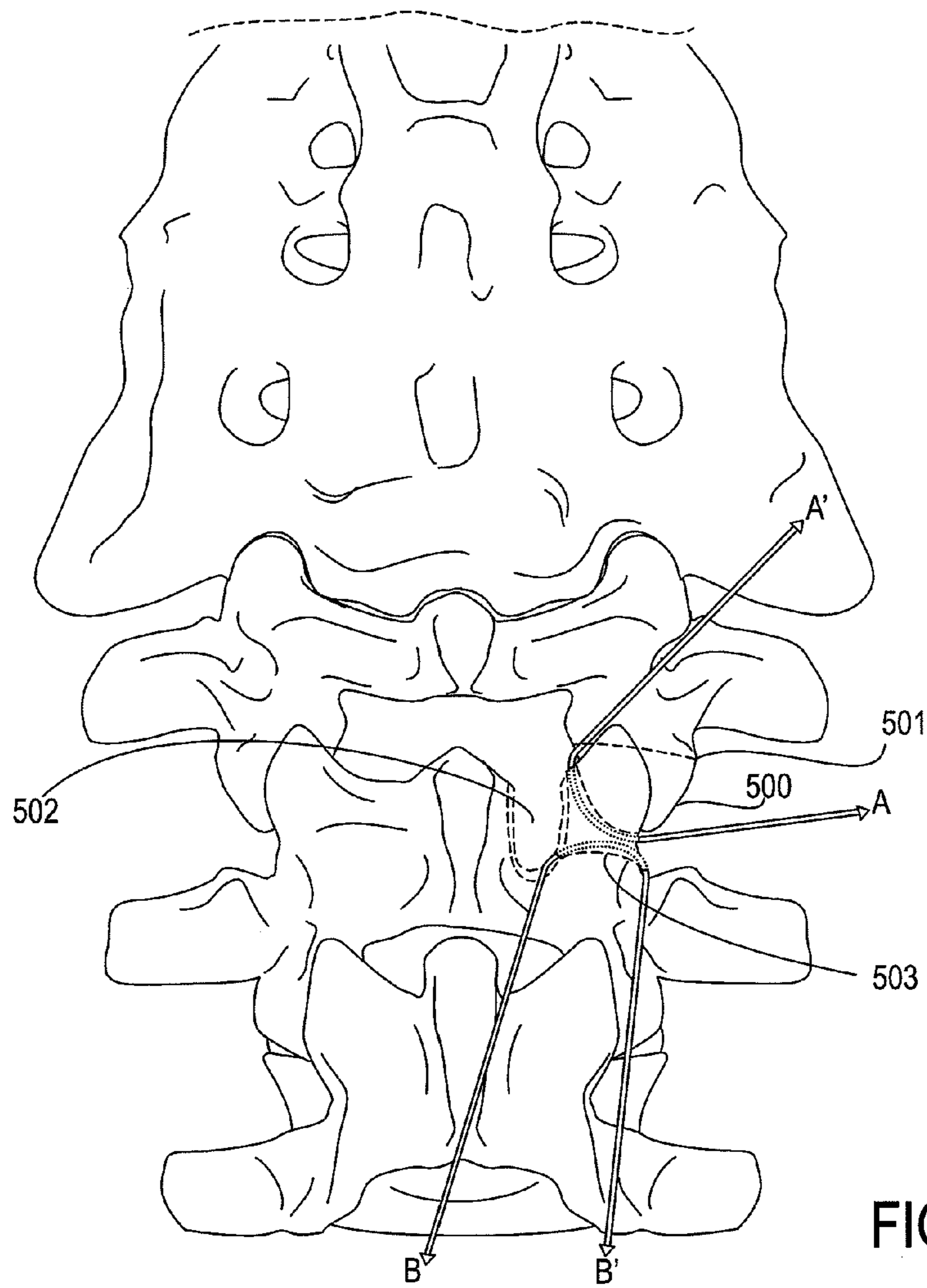

FIG. 5

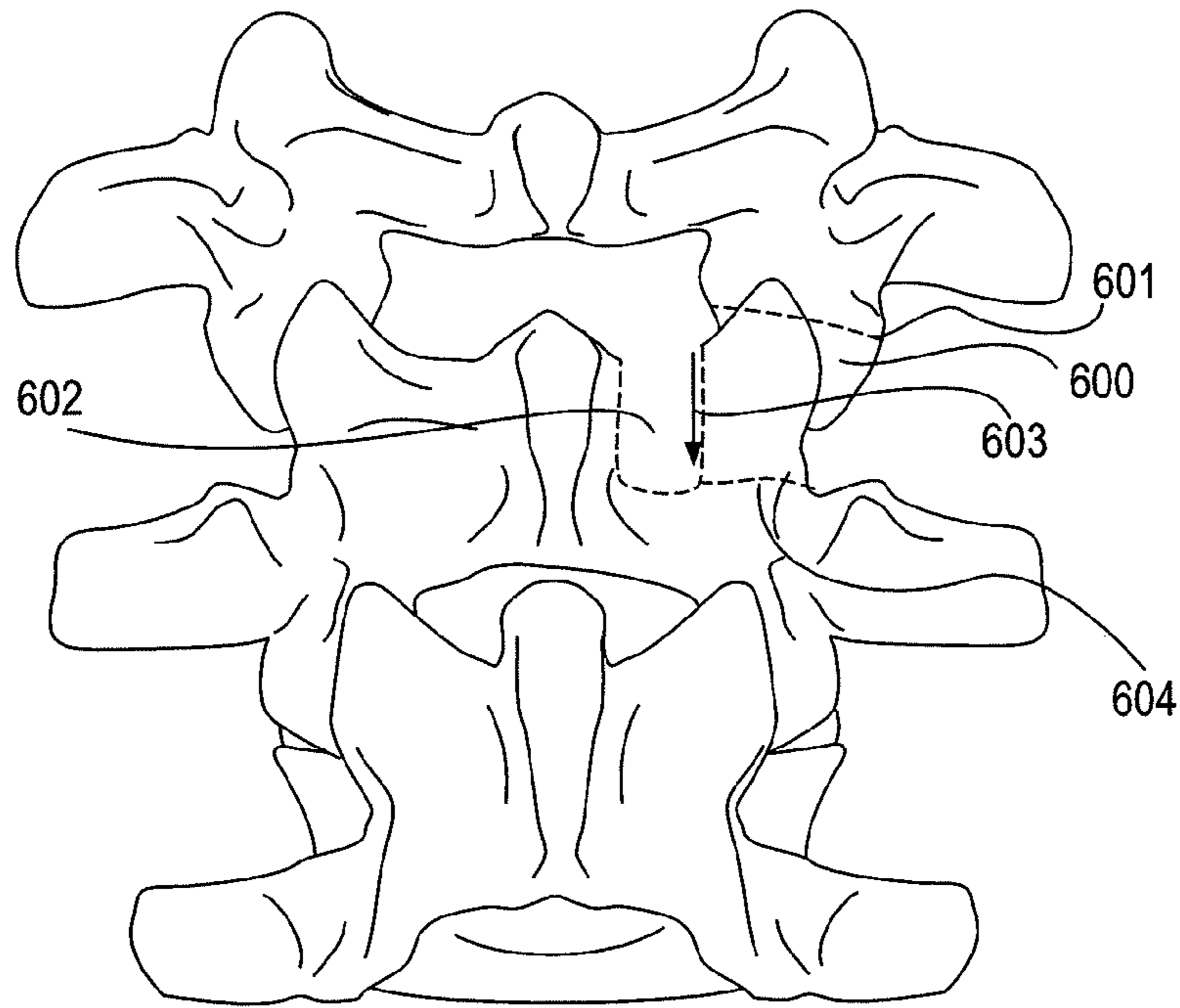

FIG. 6A

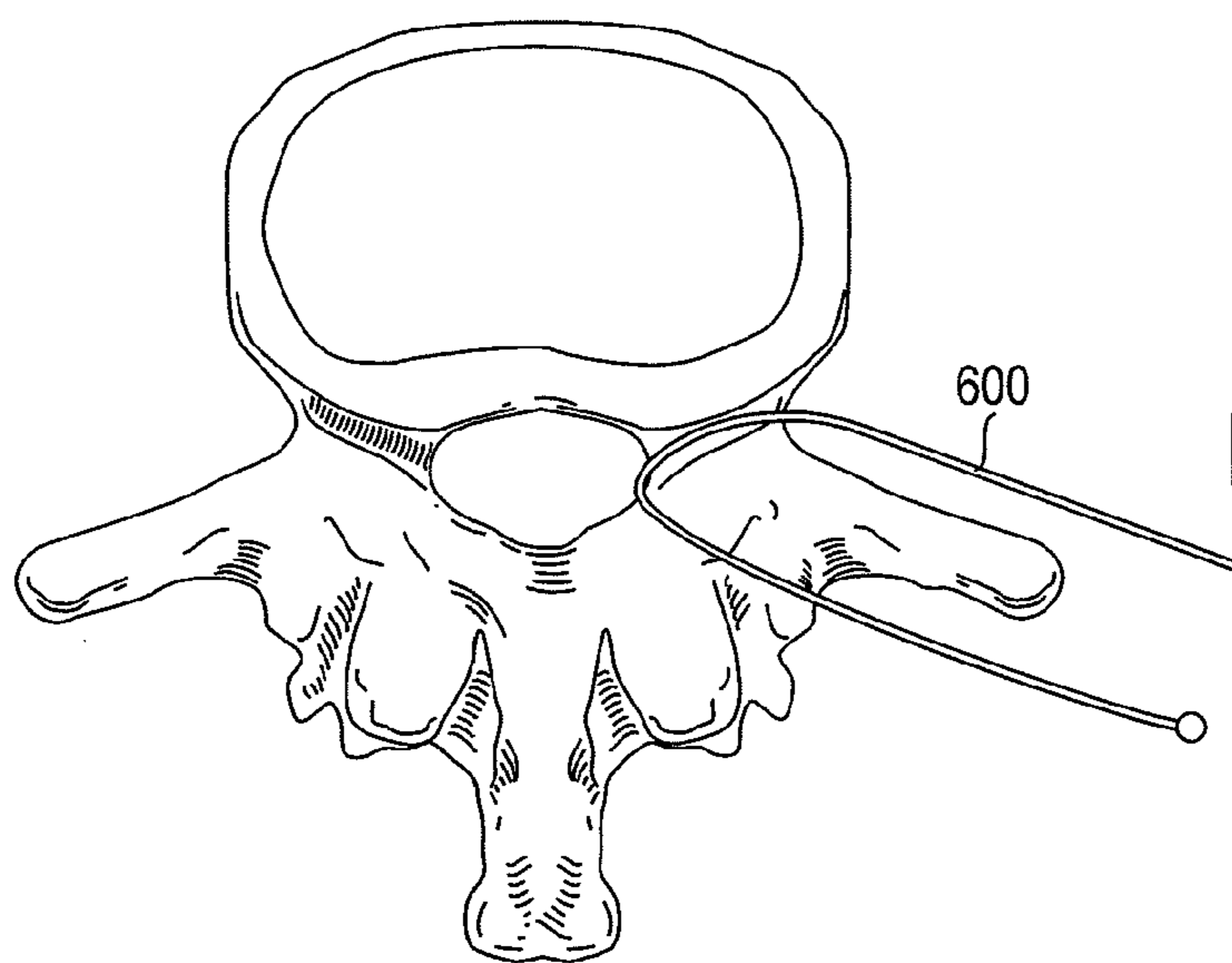

FIG. 6B

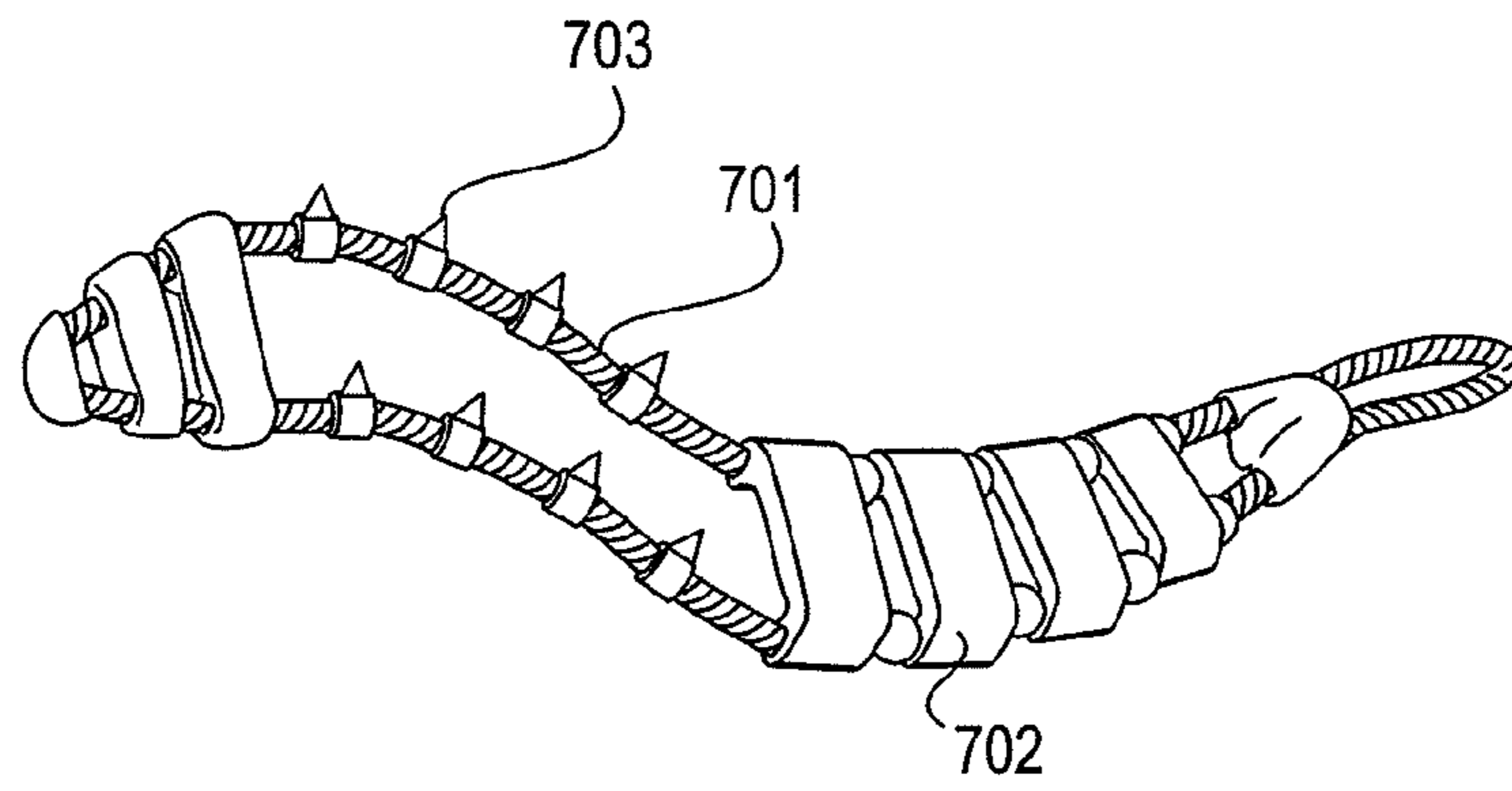

FIG. 7

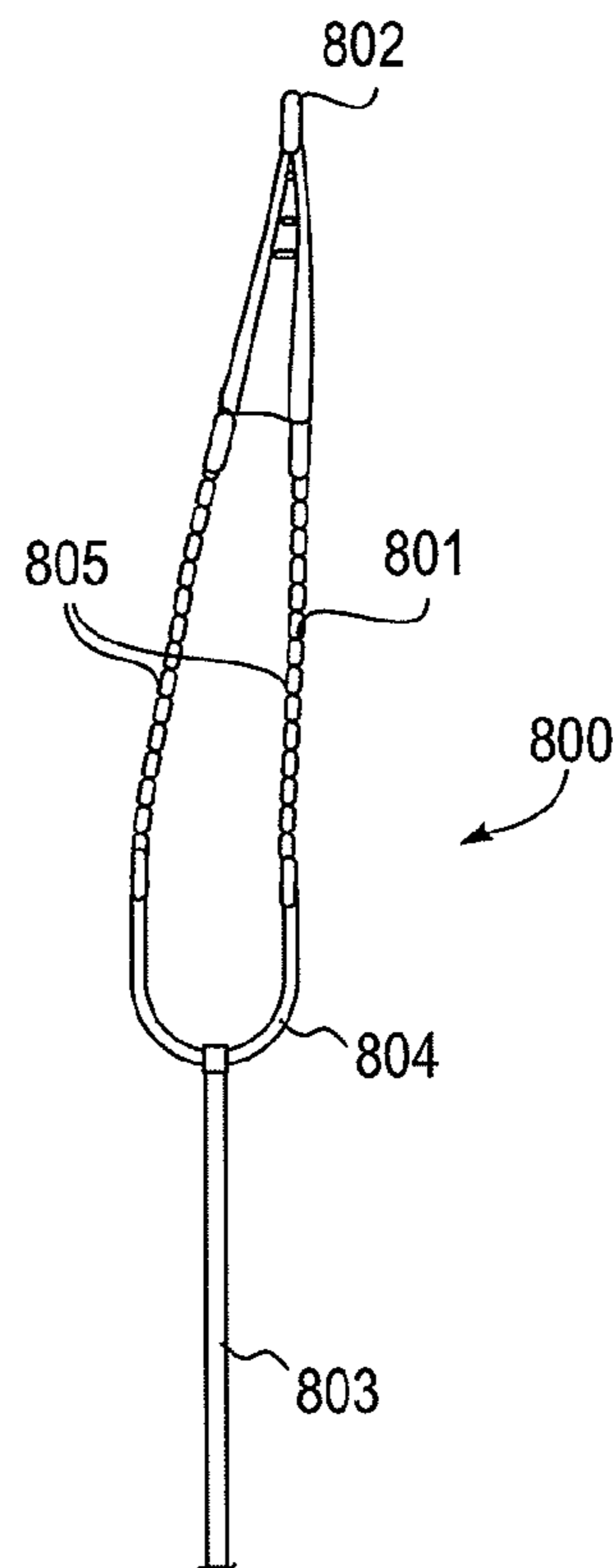

FIG. 8

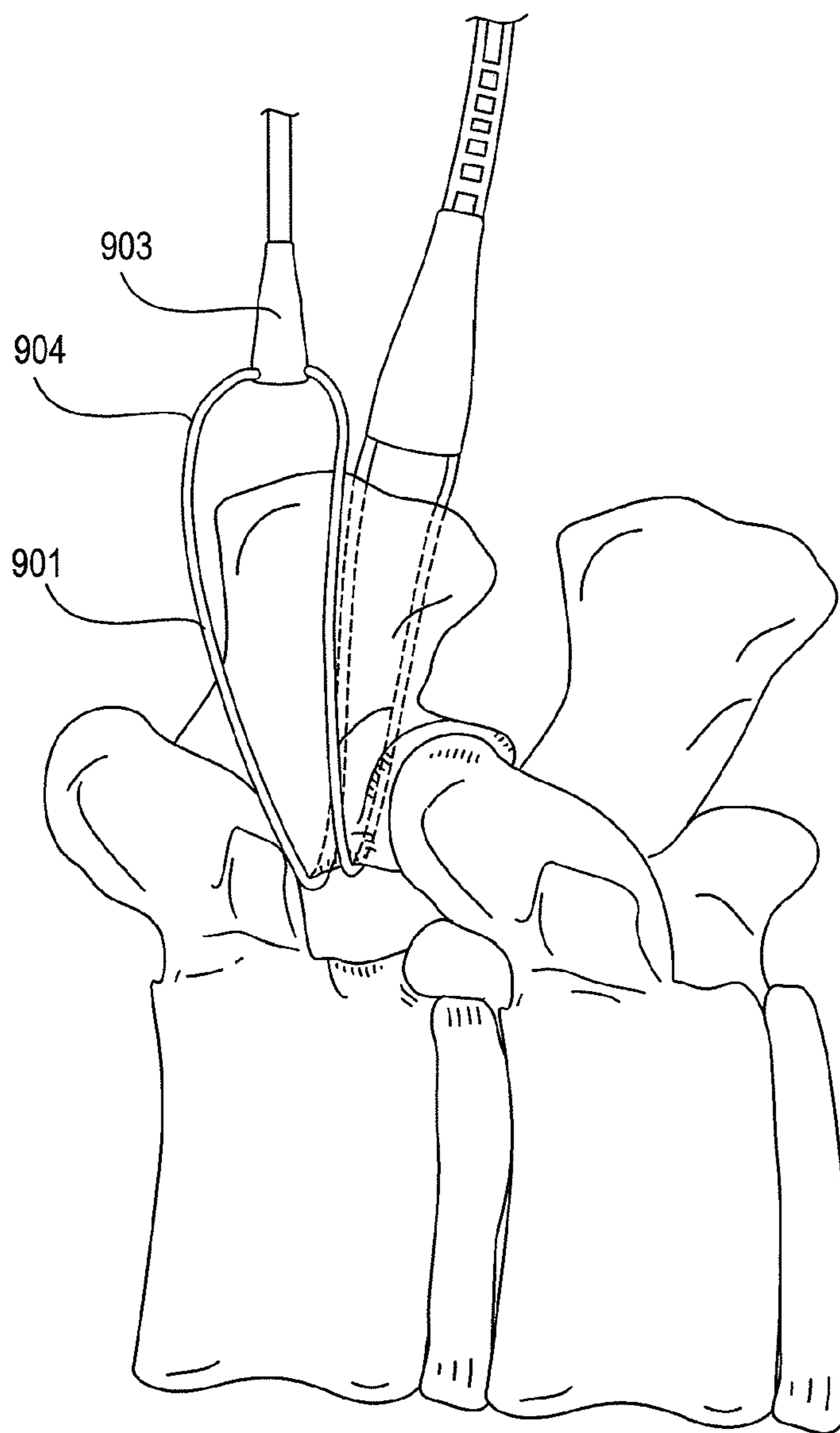

FIG. 9

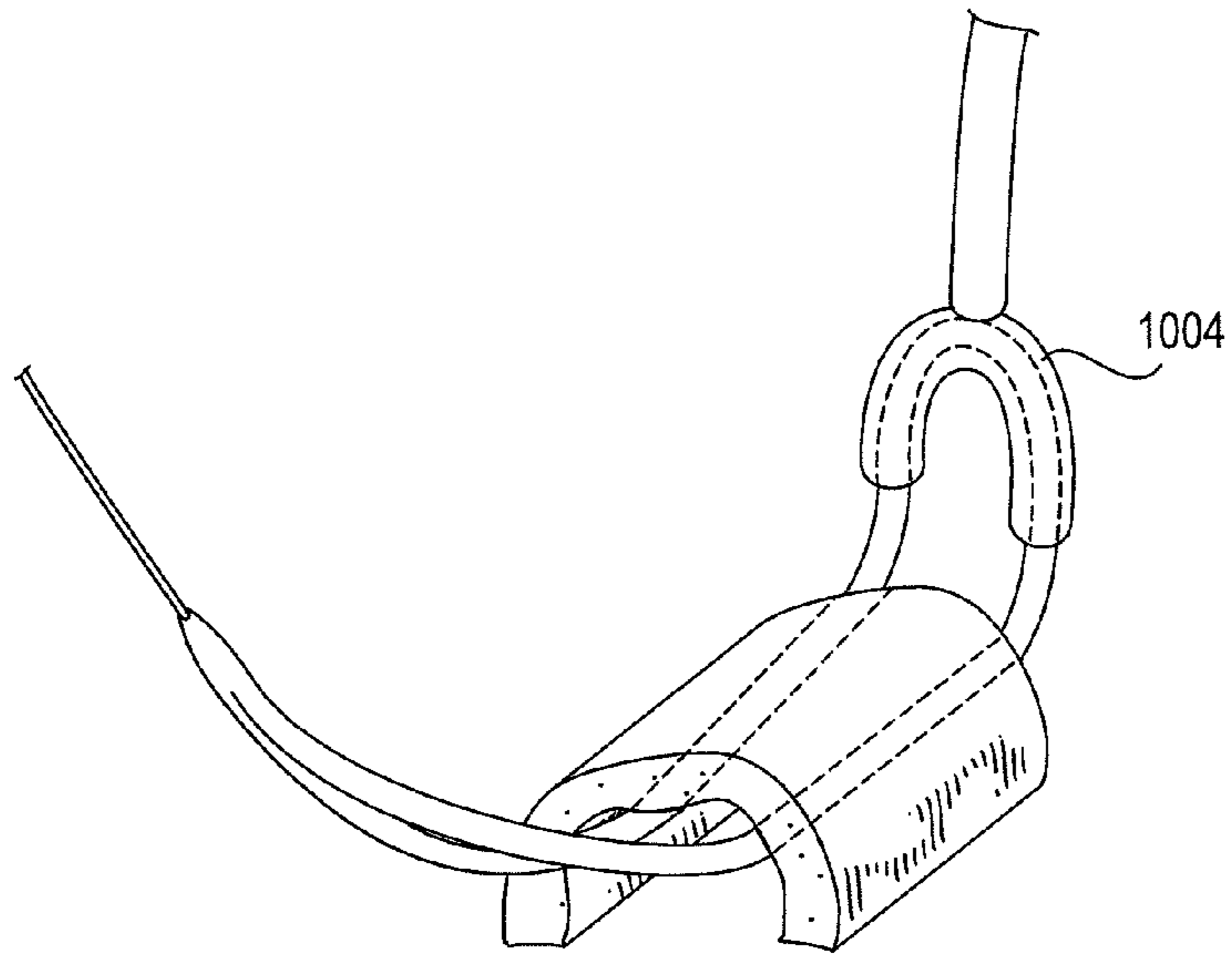

FIG. 10

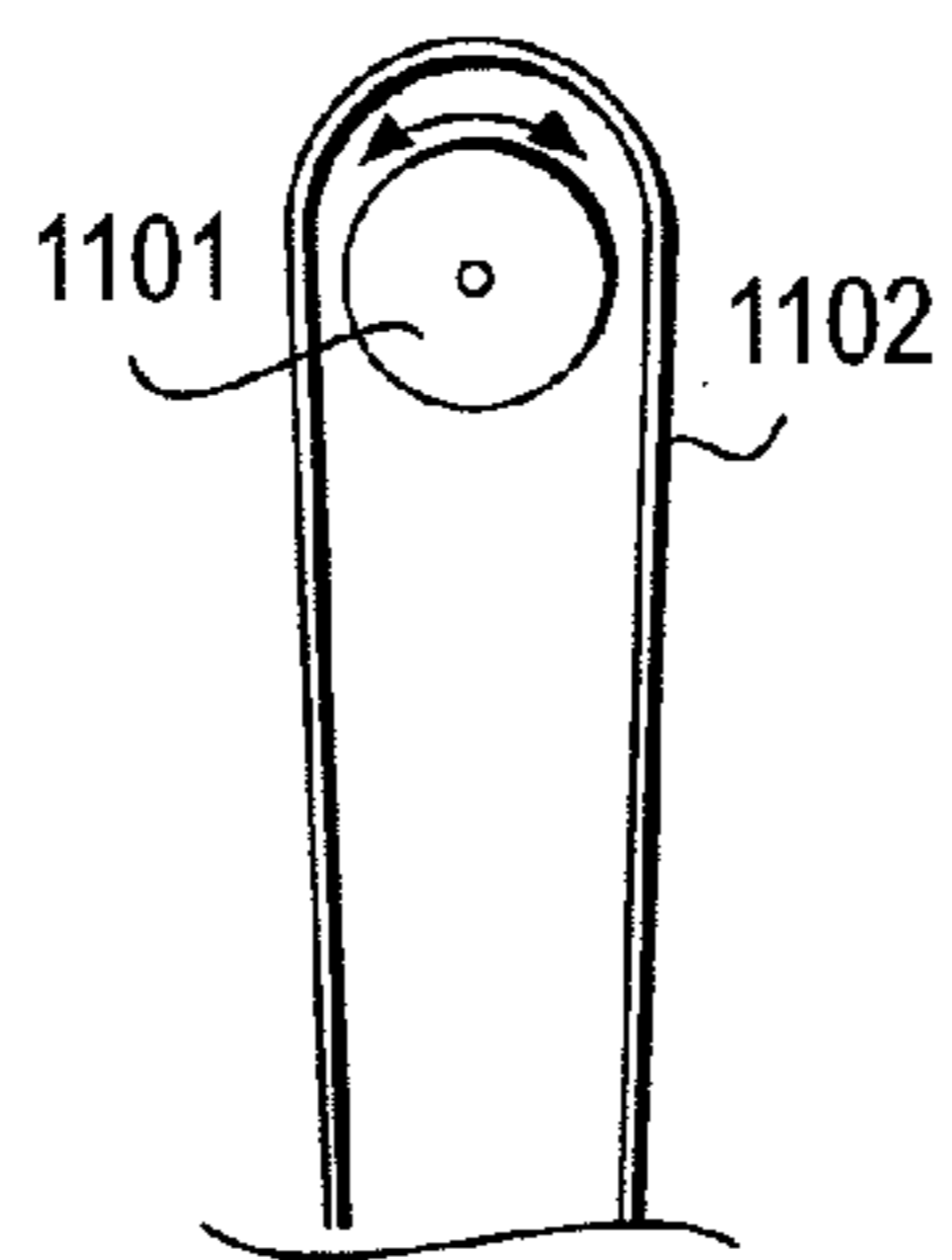

FIG. 11

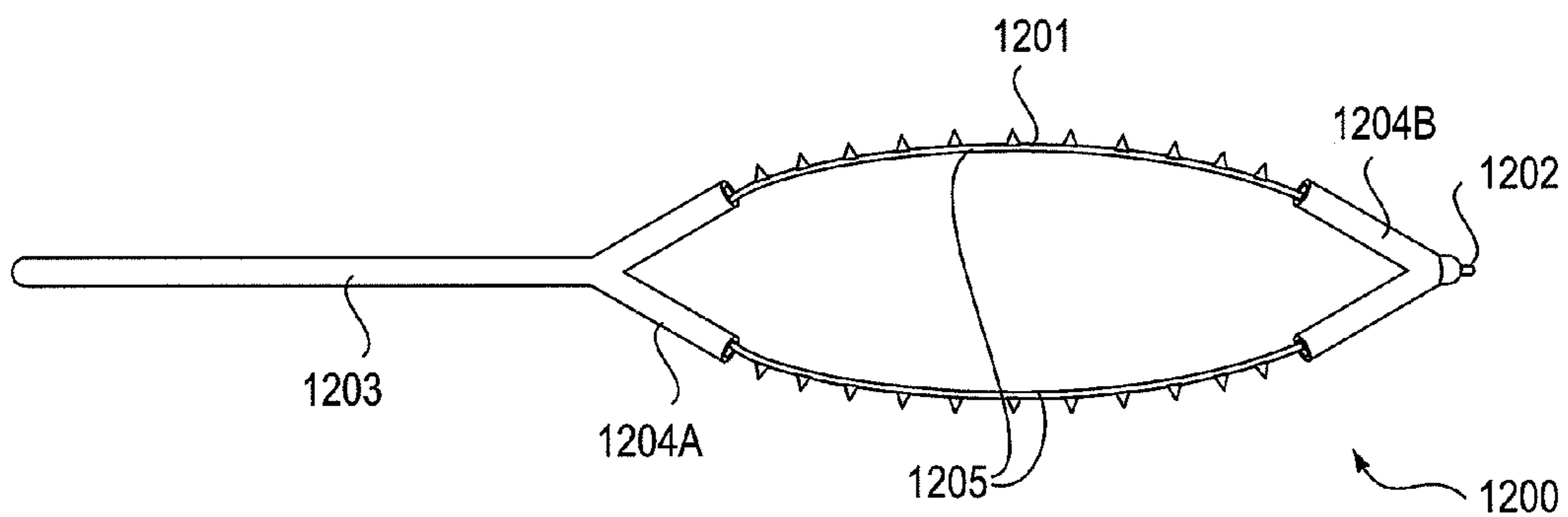

FIG. 12

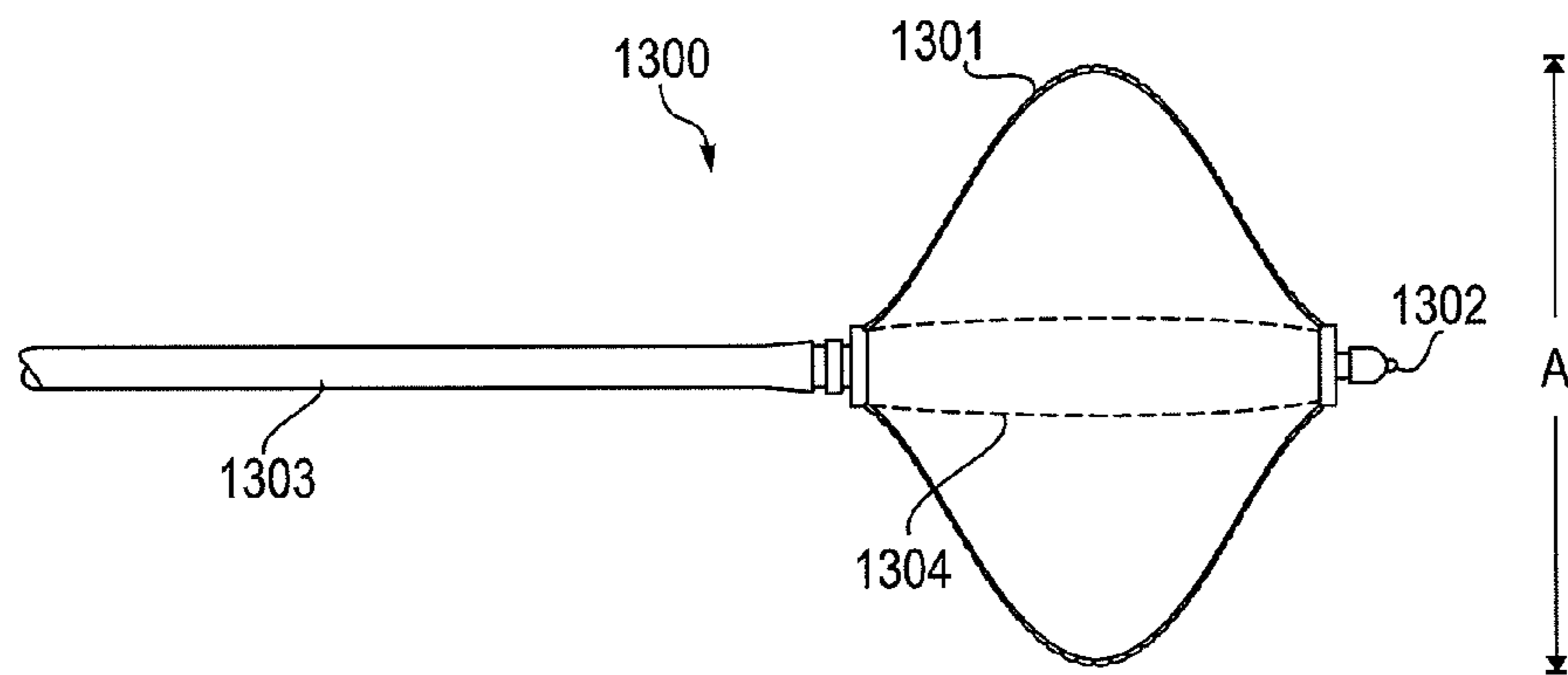

FIG. 13A

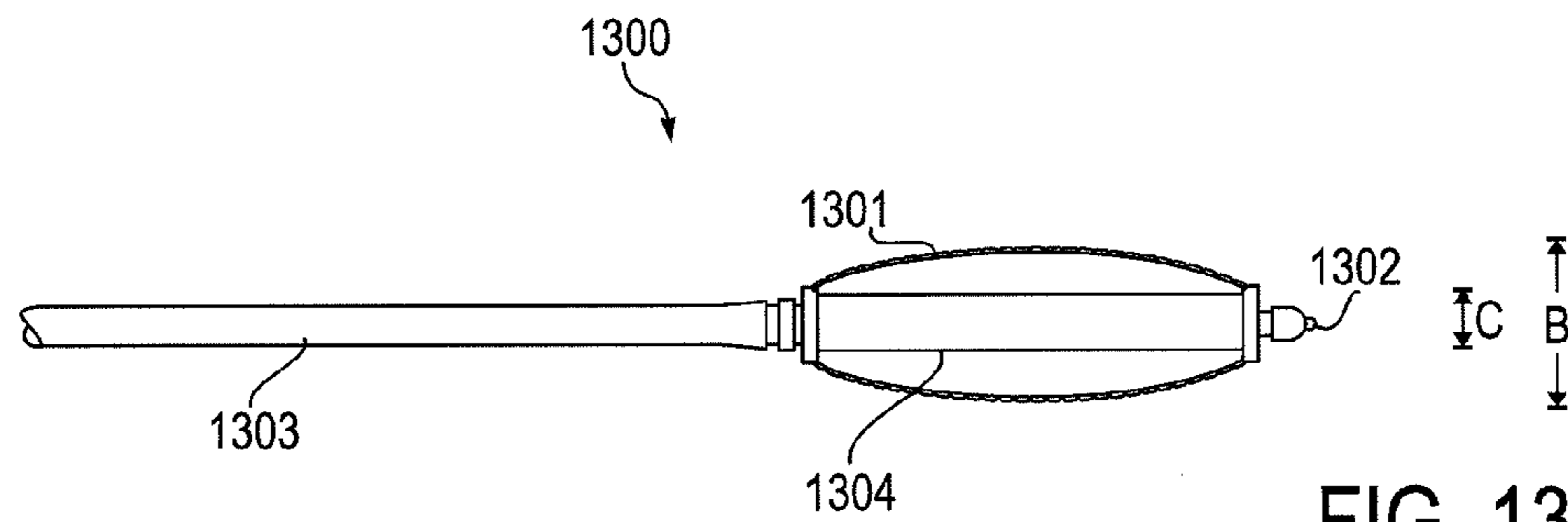
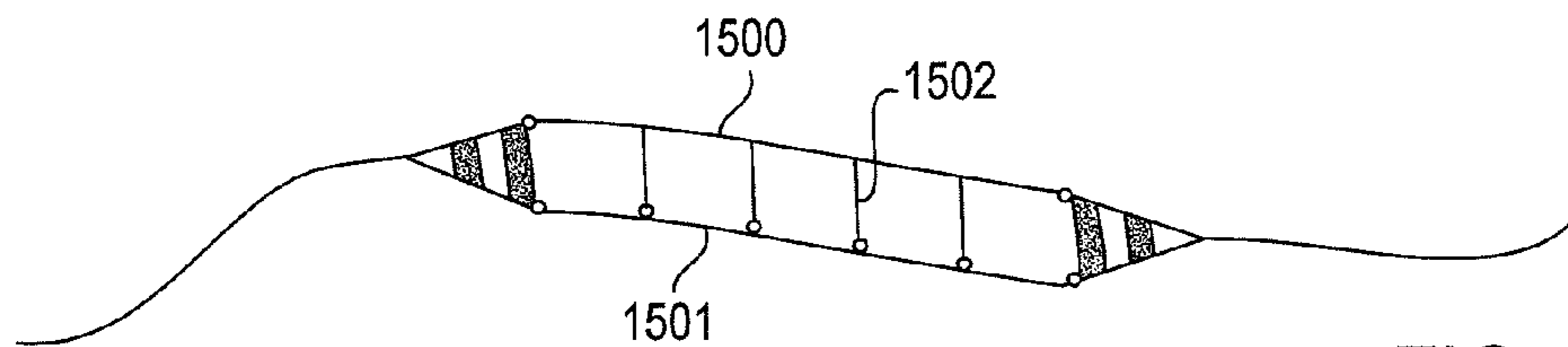
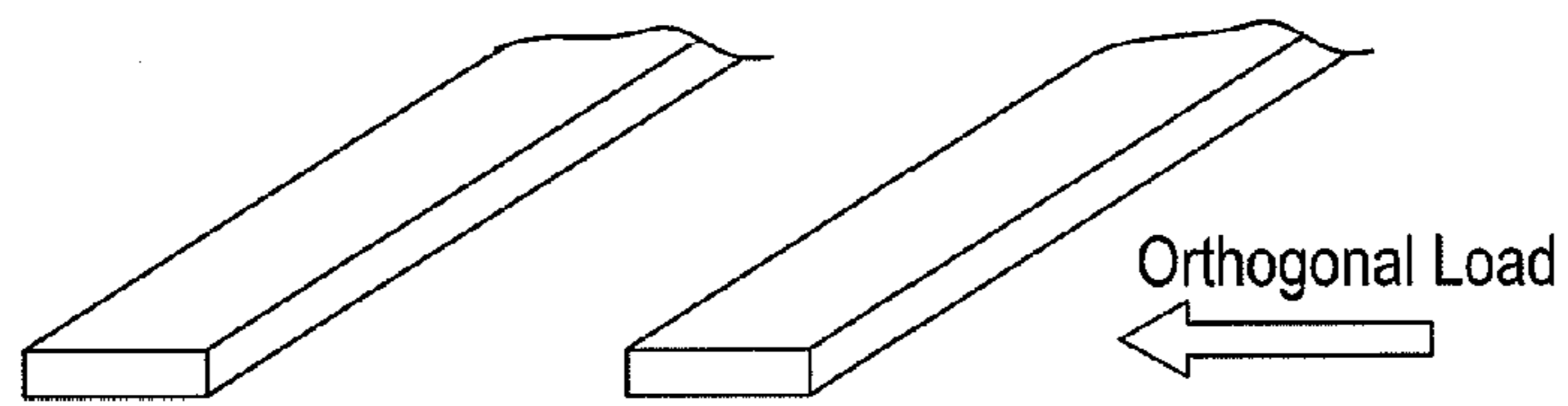
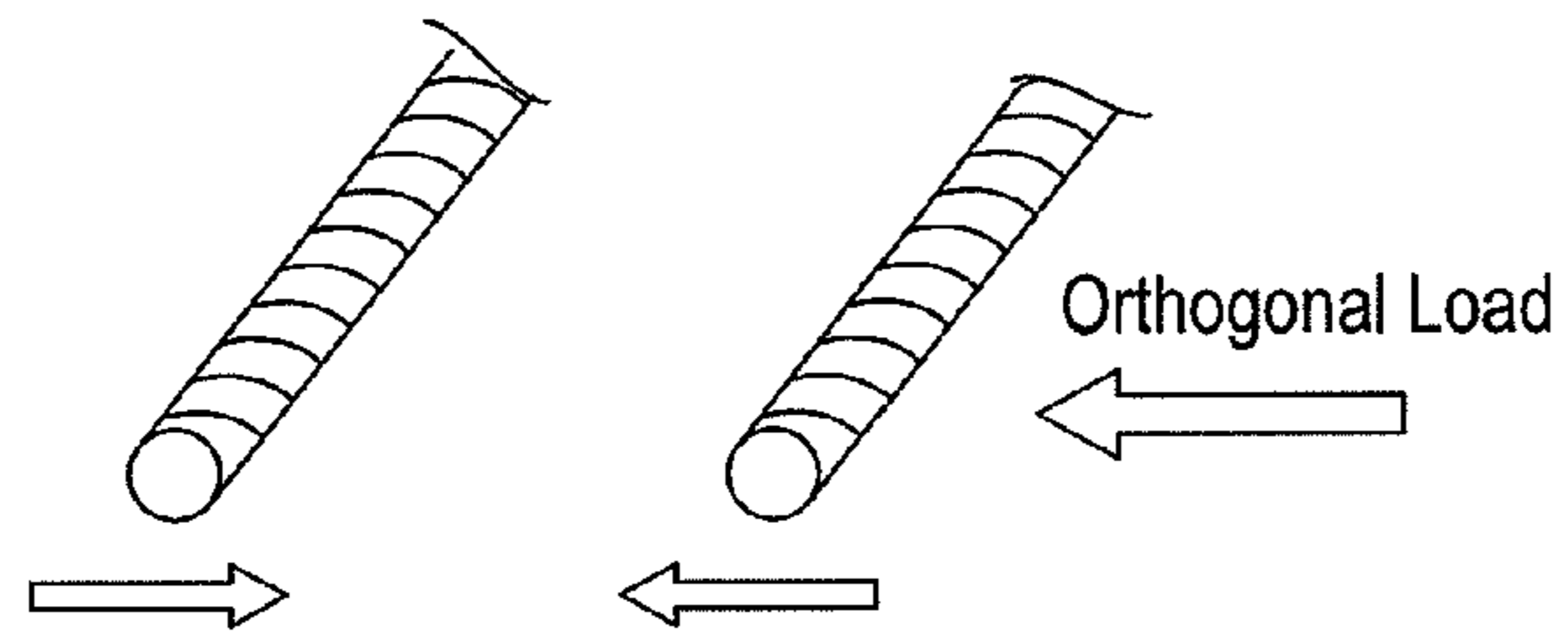
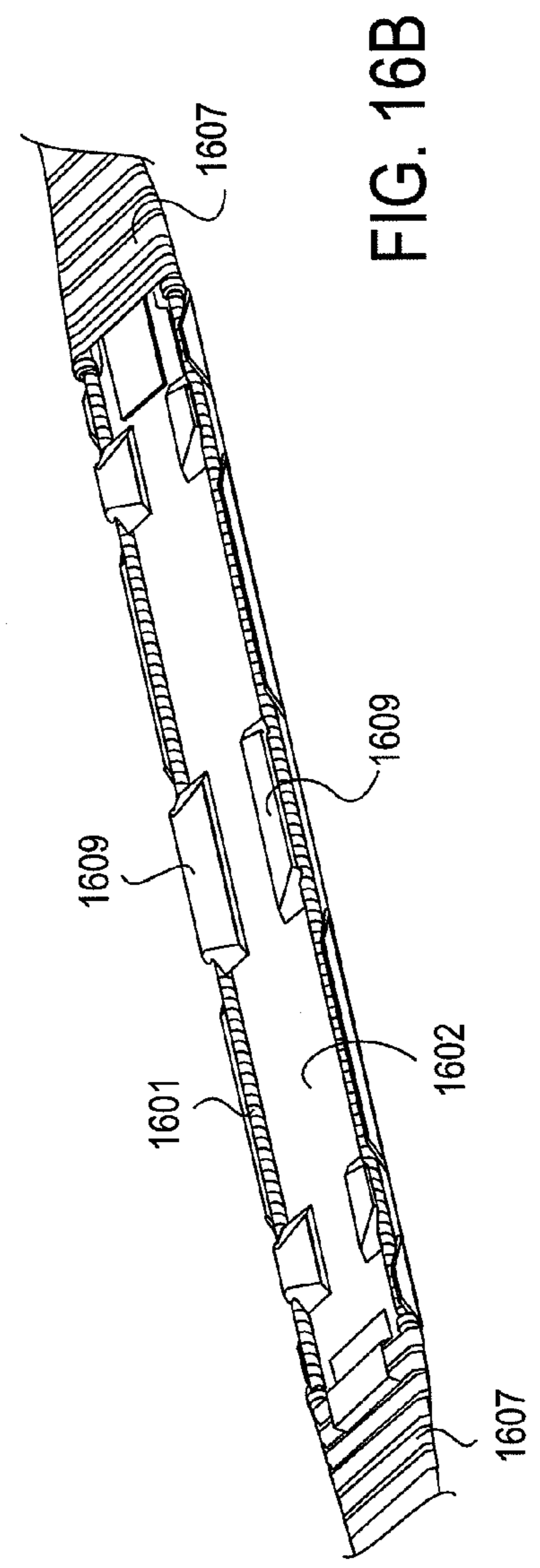
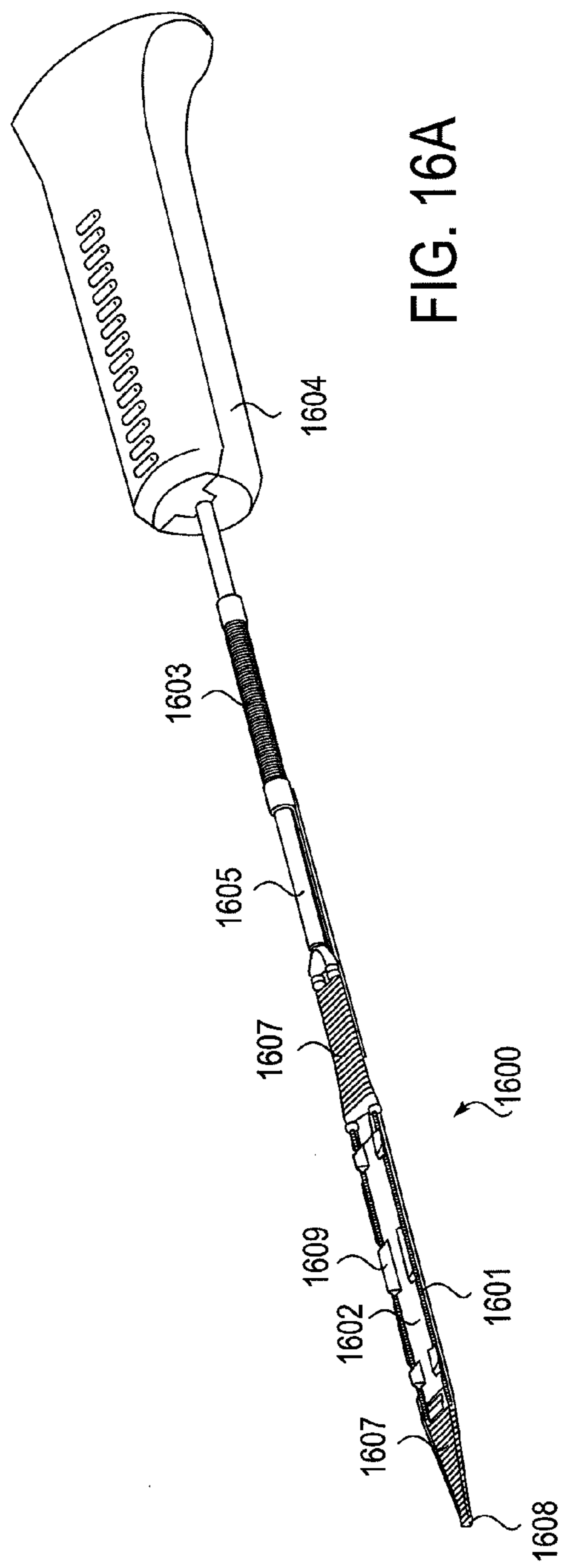

FIG. 13B





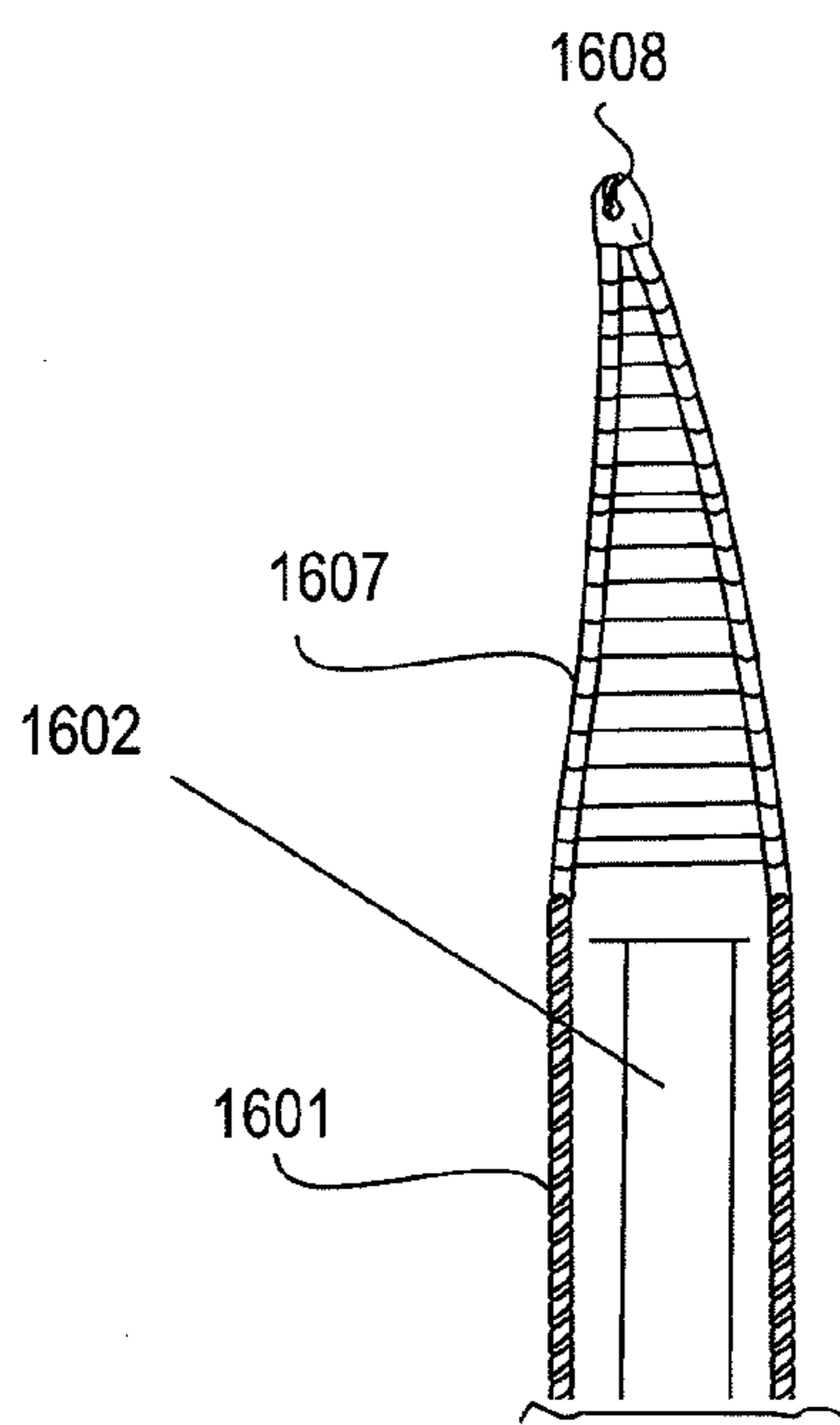

FIG. 16C

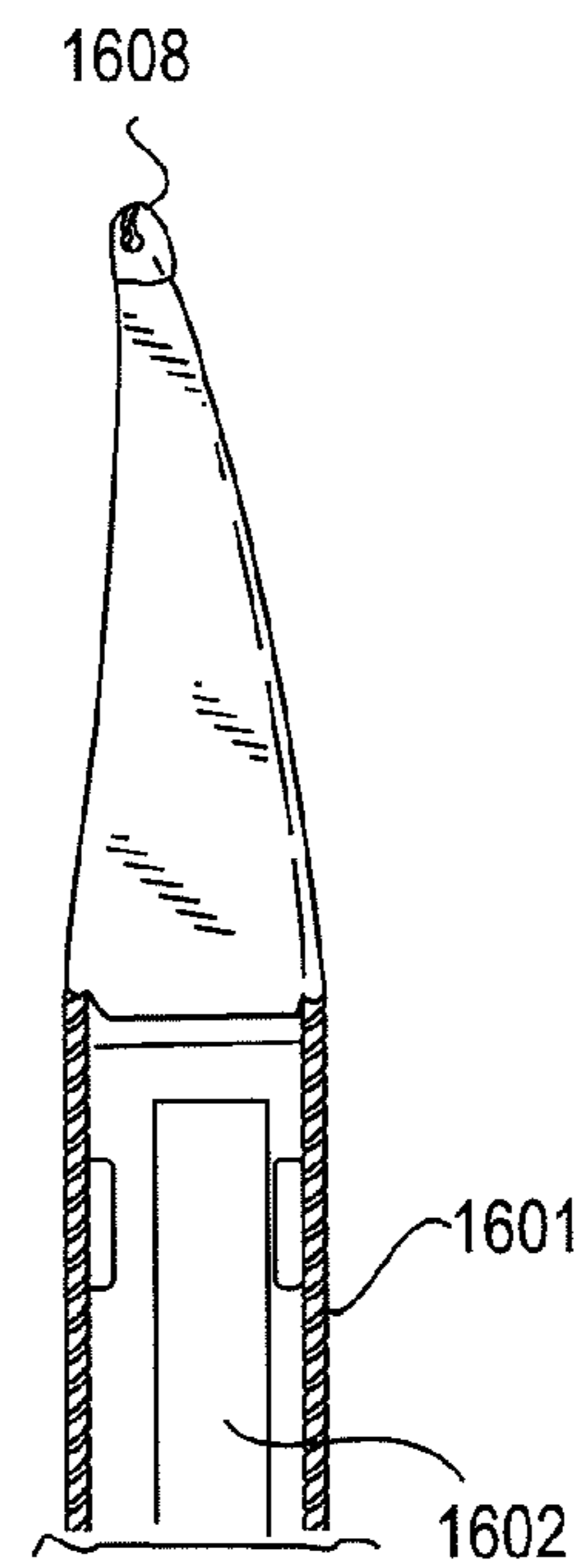

FIG. 16D

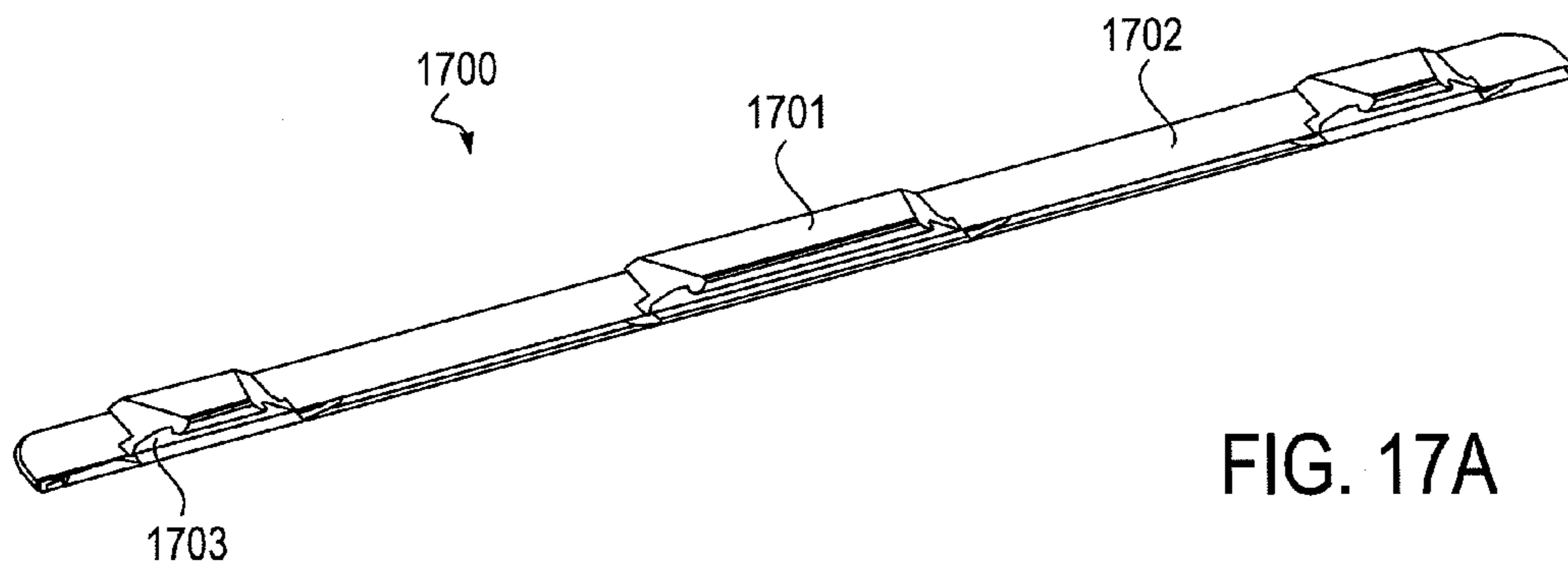

FIG. 17A

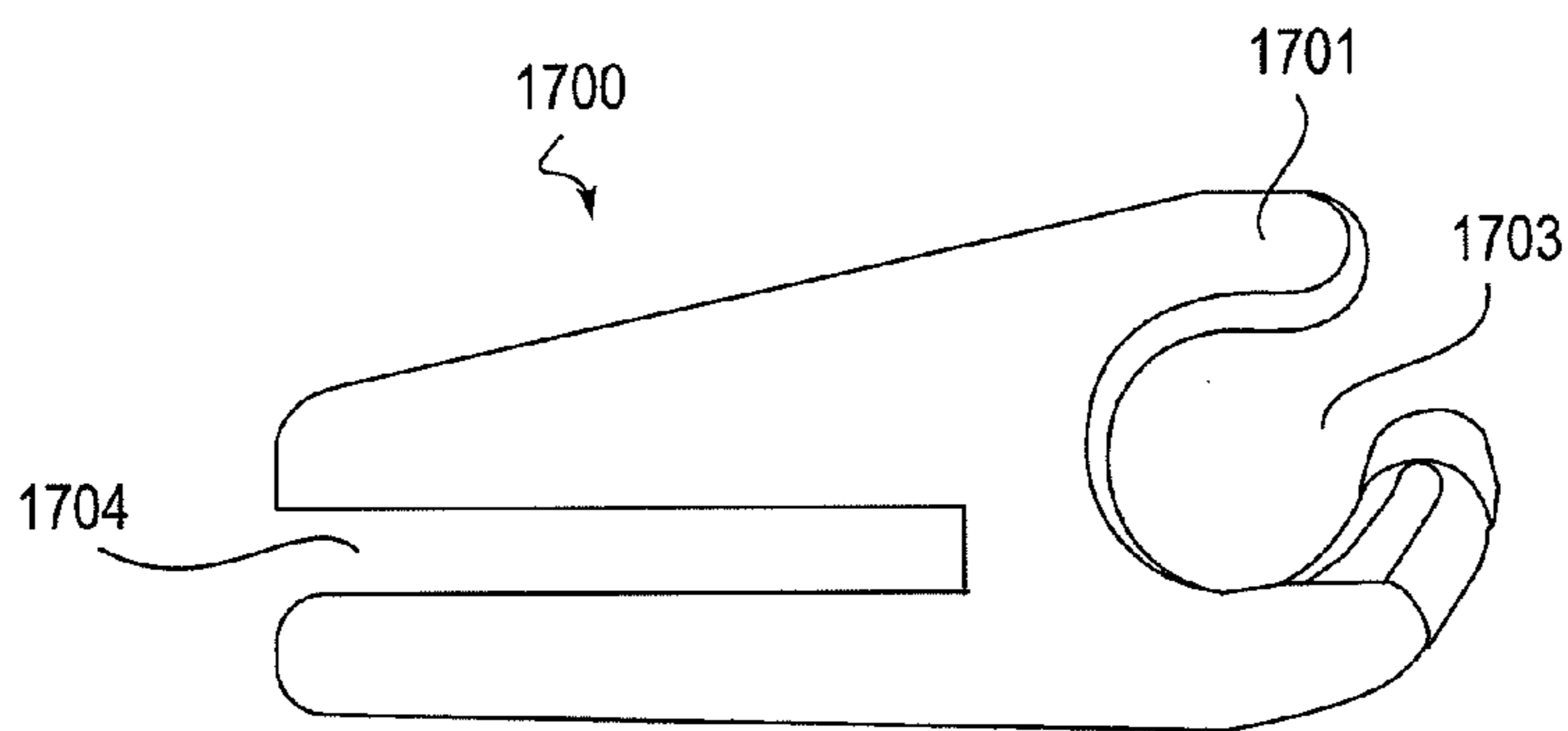

FIG. 17B

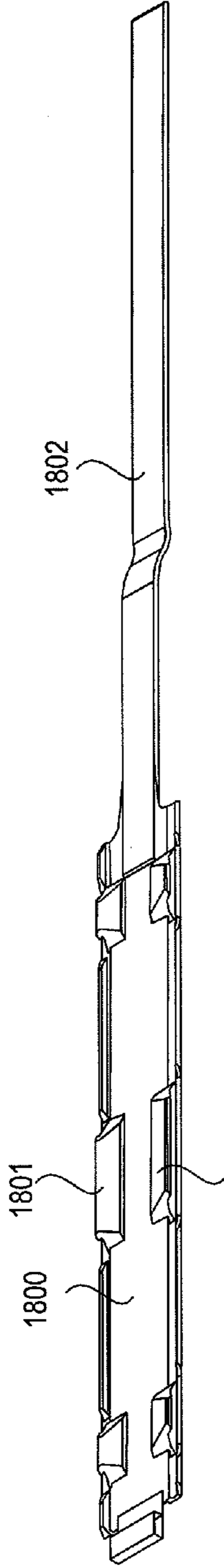

FIG. 18A

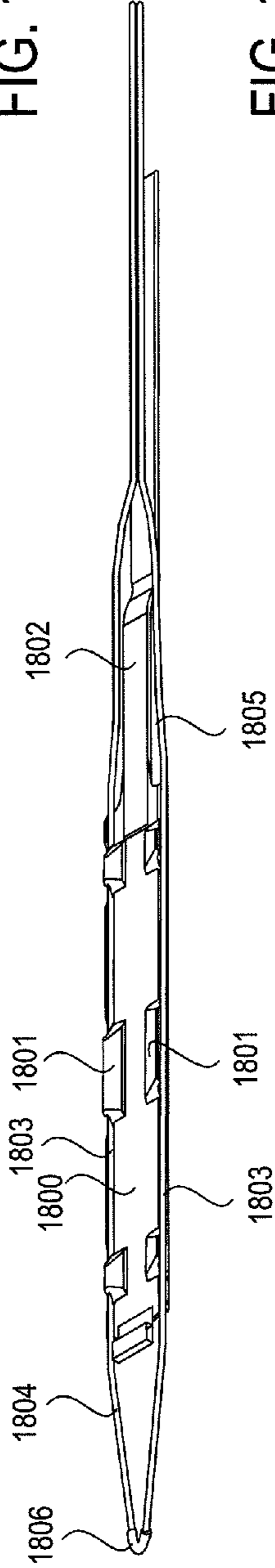

FIG. 18B

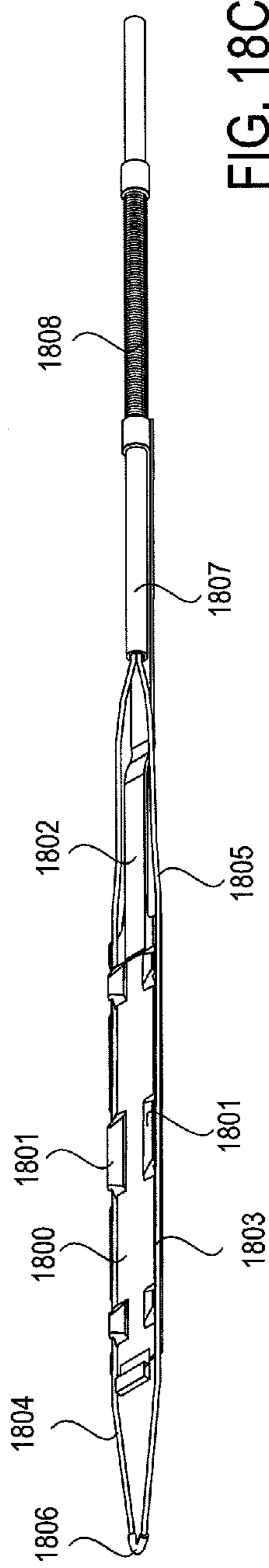

FIG. 18C

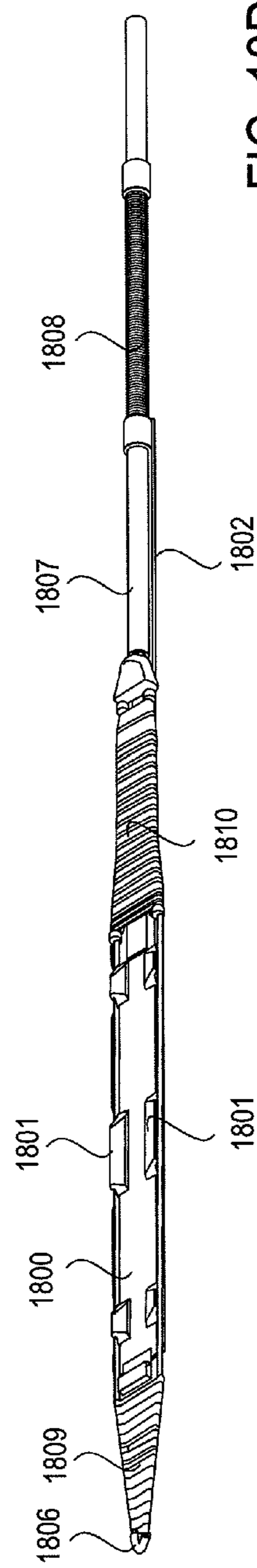

FIG. 18D

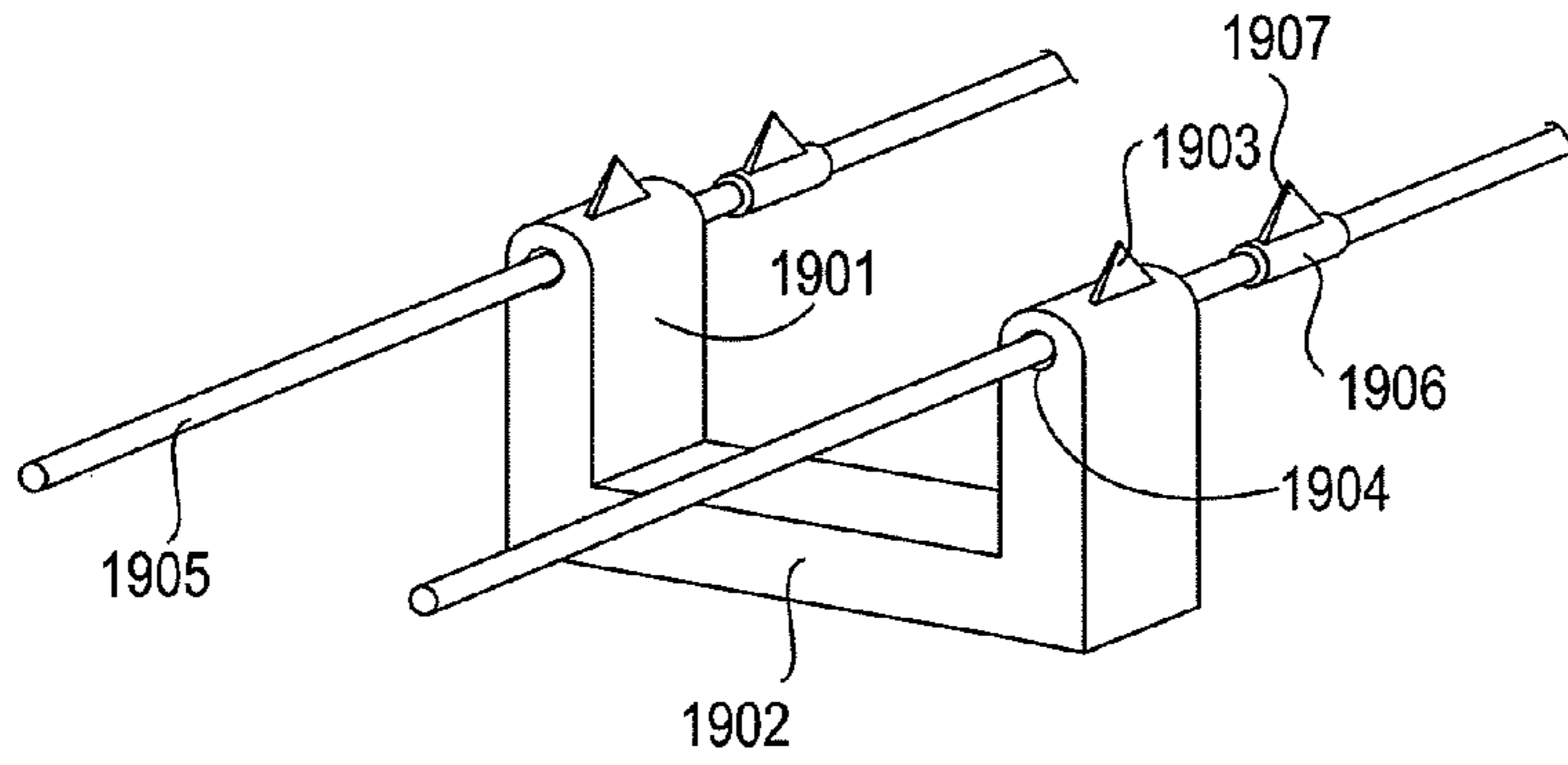

FIG. 19A

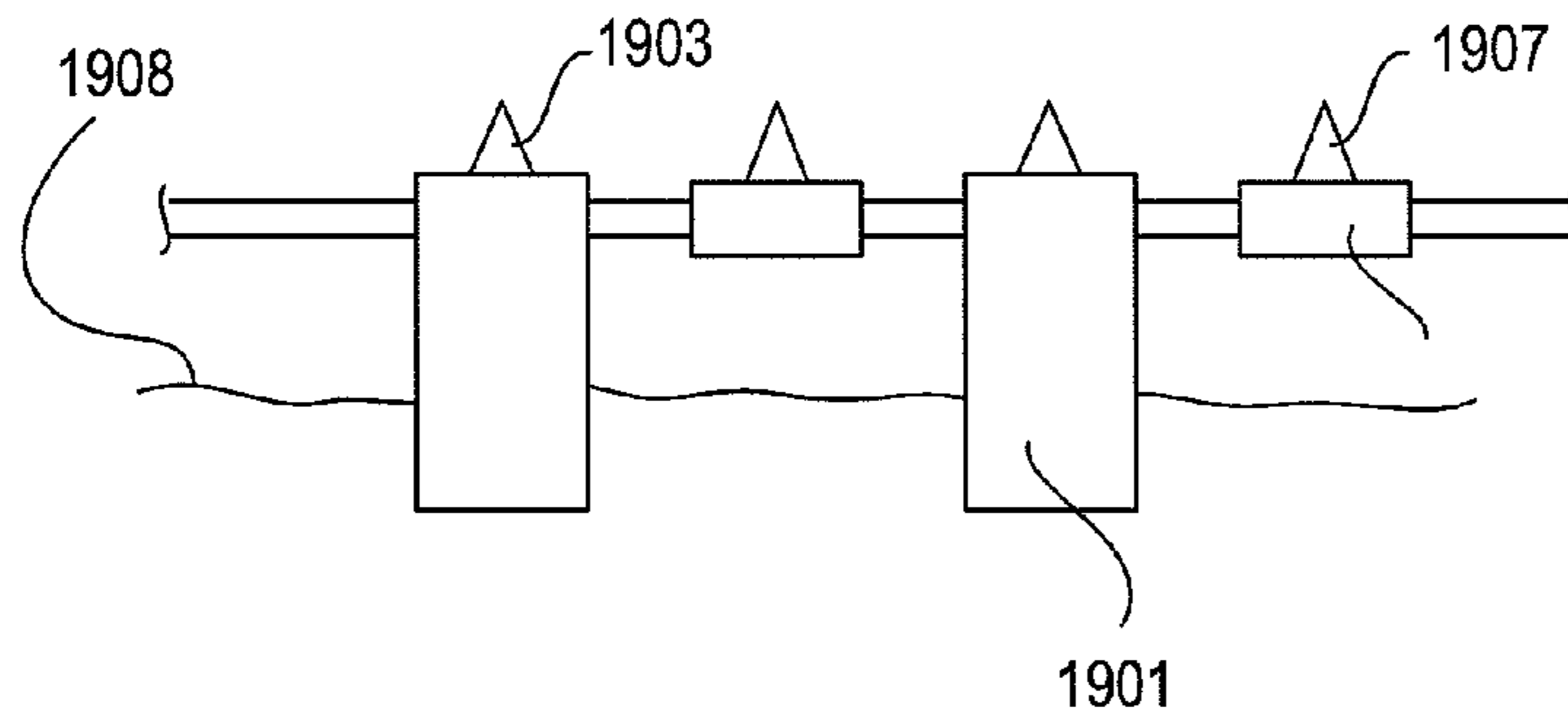

FIG. 19B

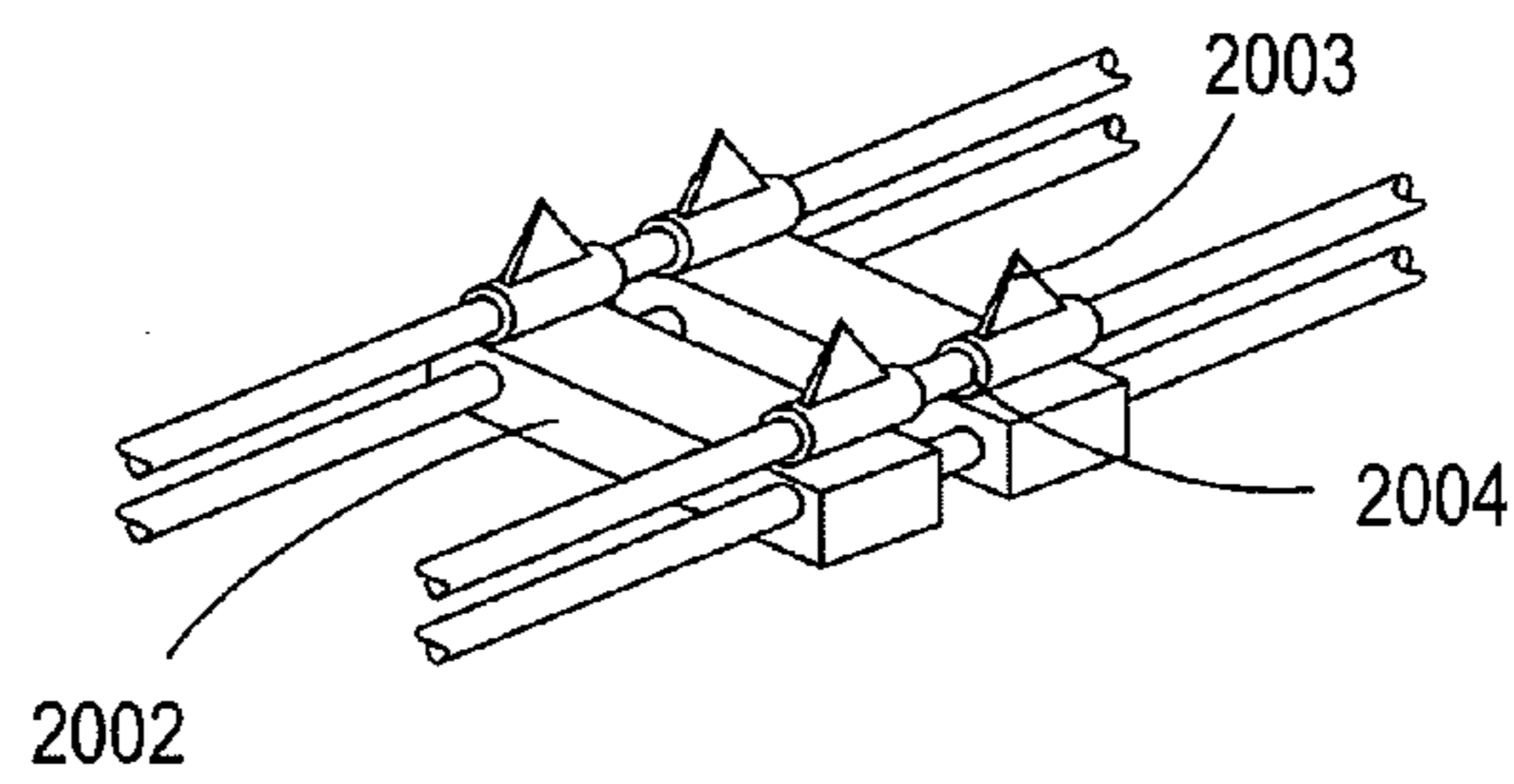

FIG. 20A

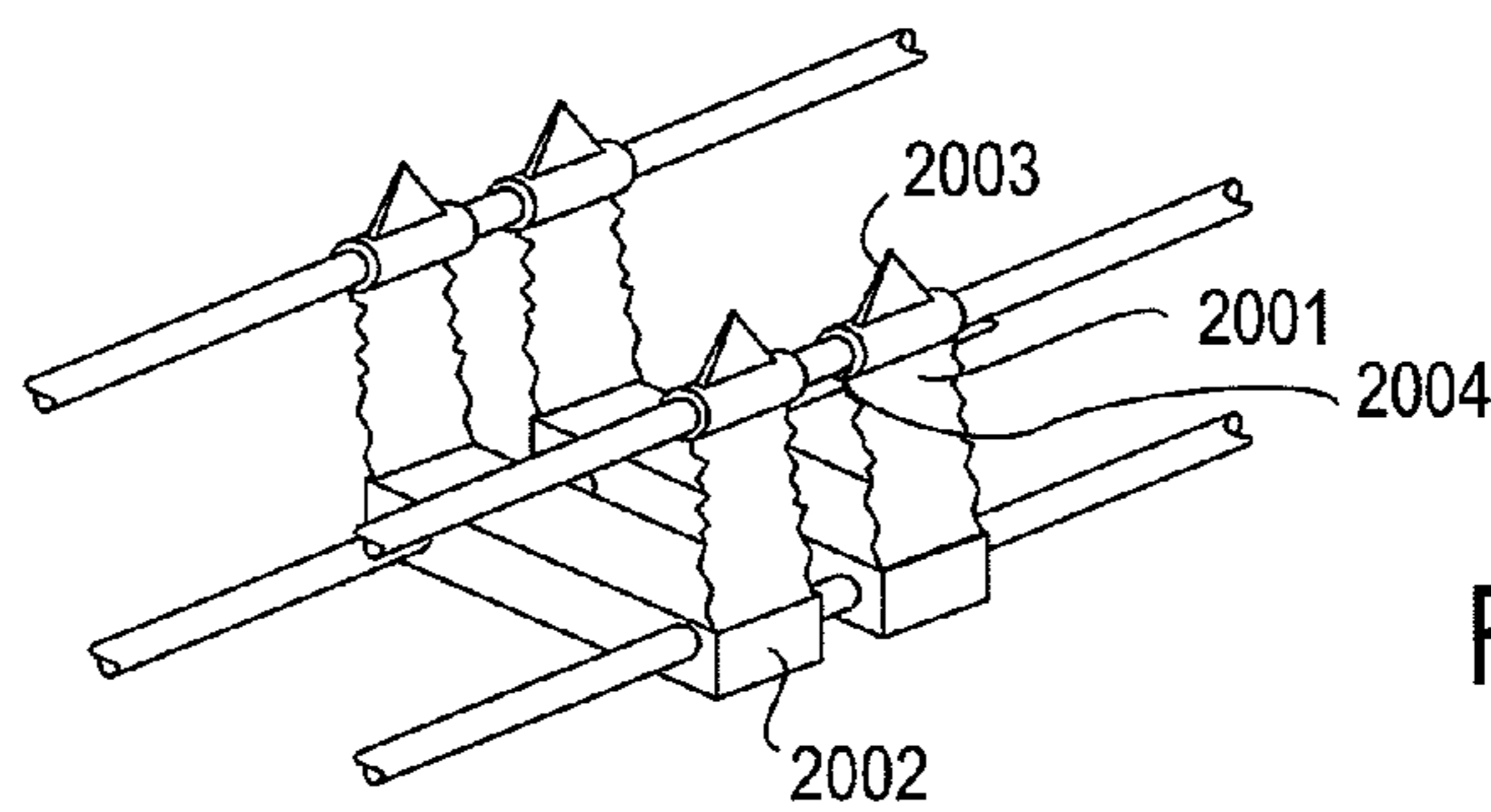

FIG. 20B

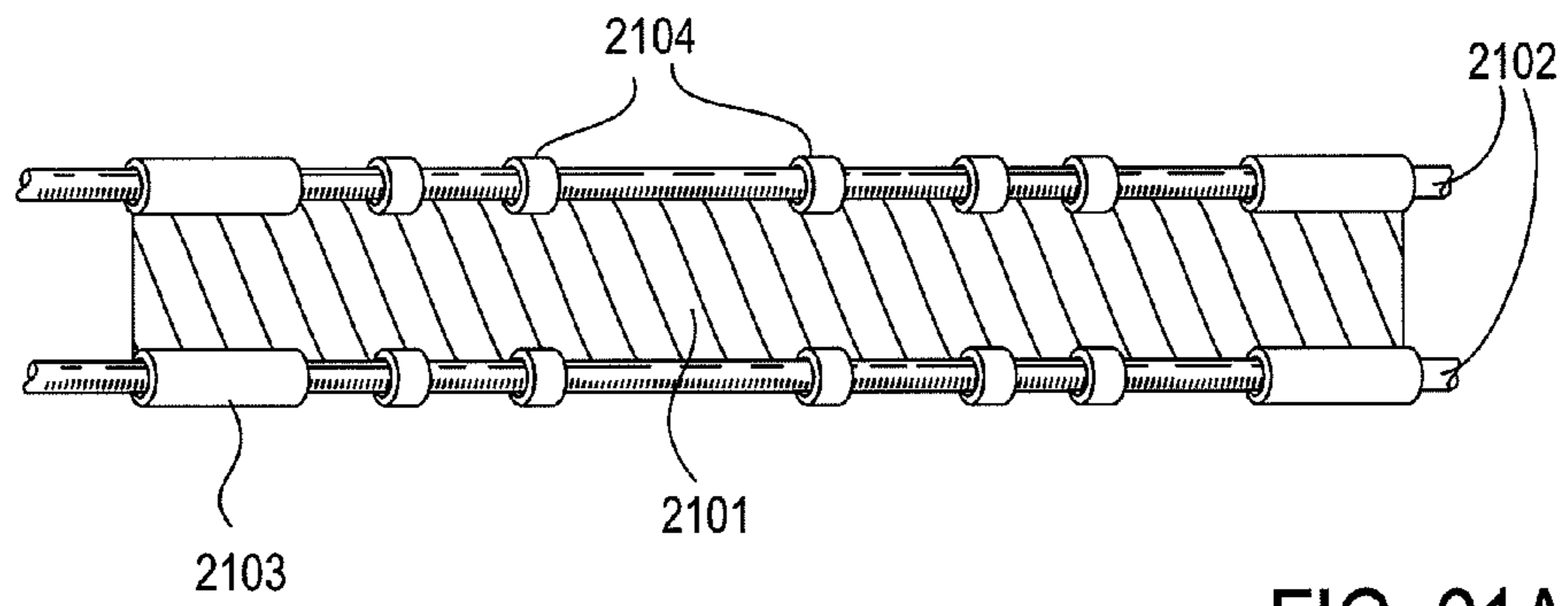

FIG. 21A

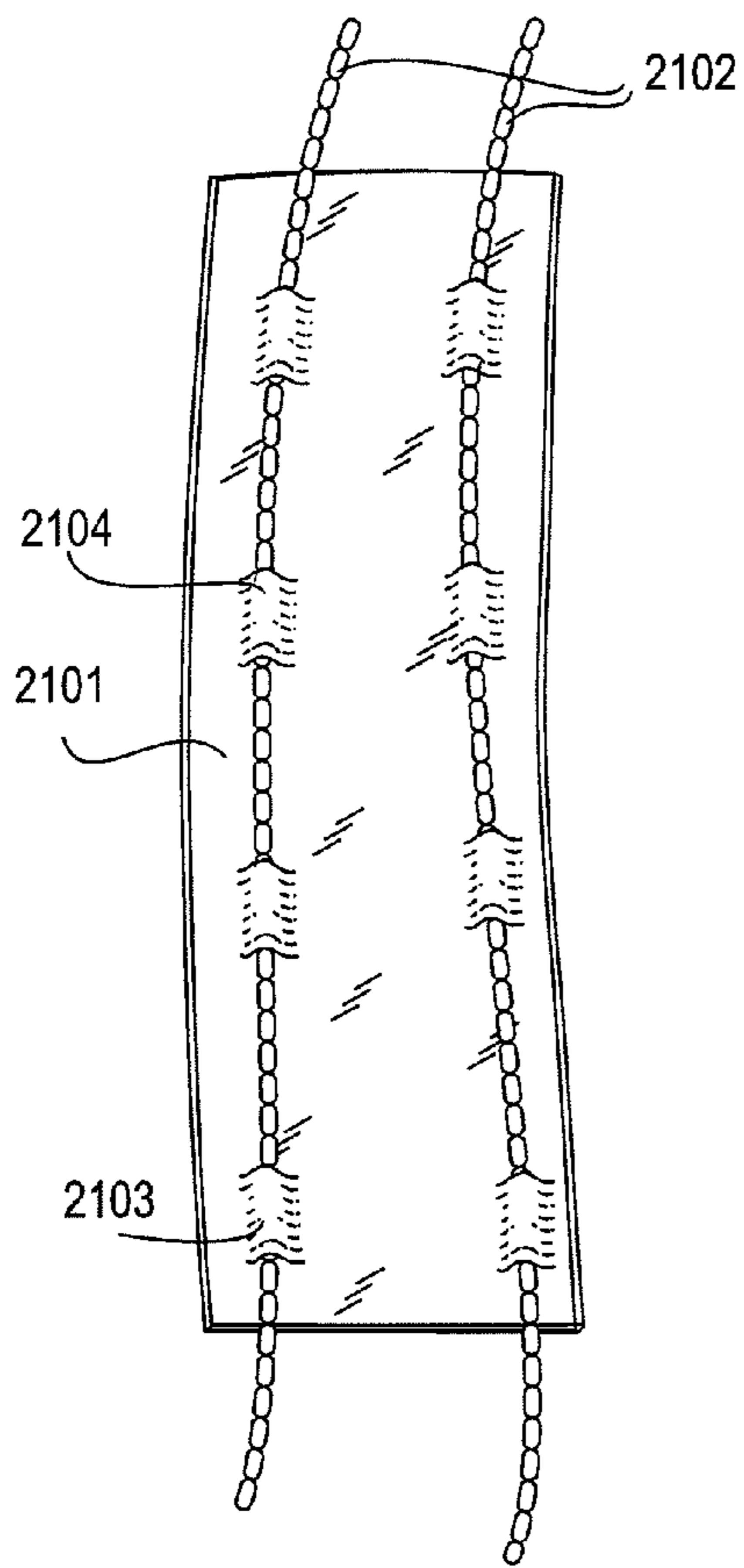

FIG. 21B

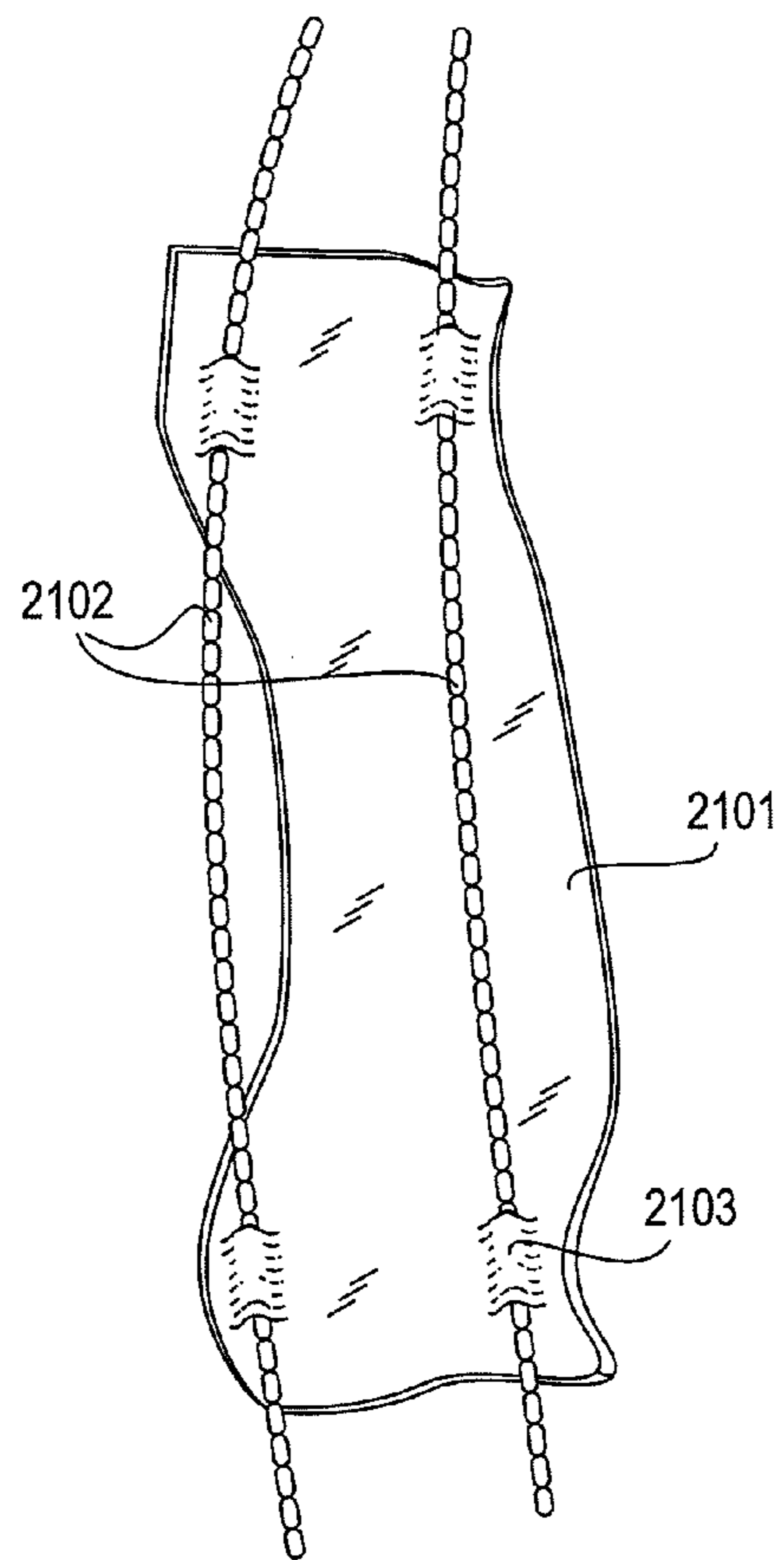

FIG. 21C

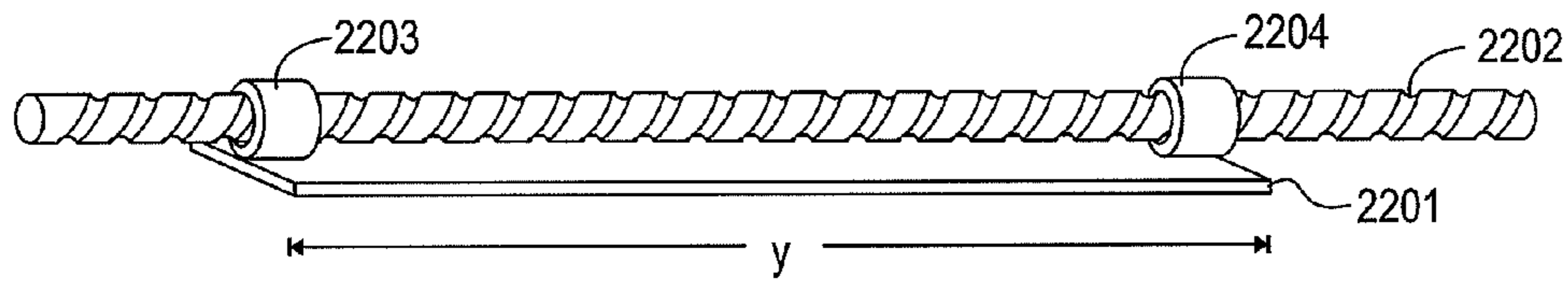

FIG. 22A

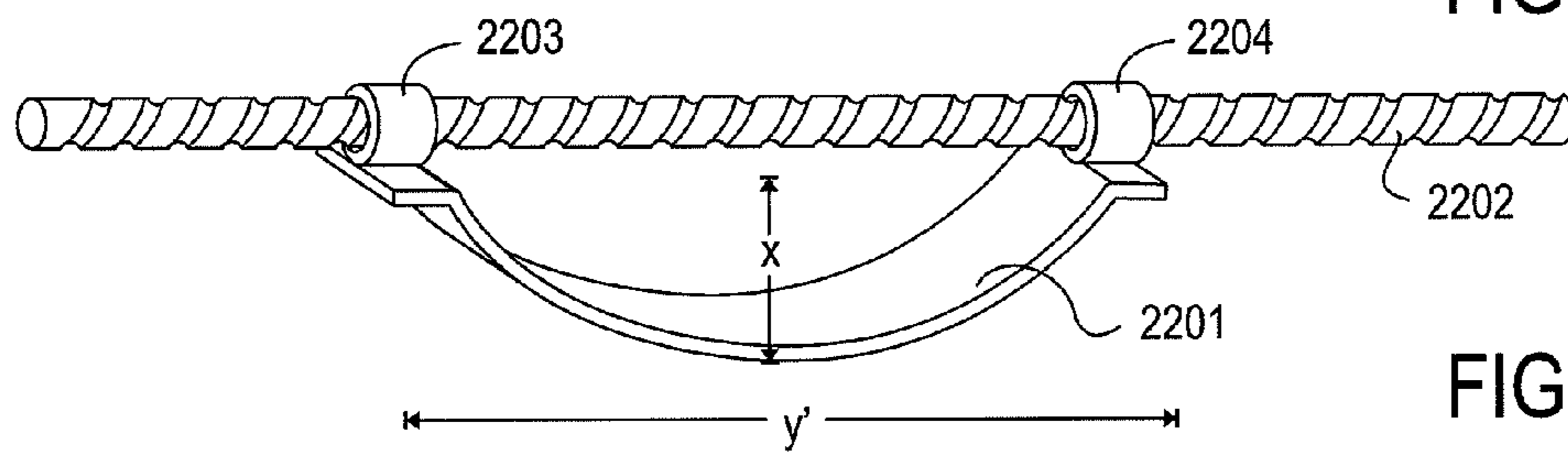

FIG. 22B

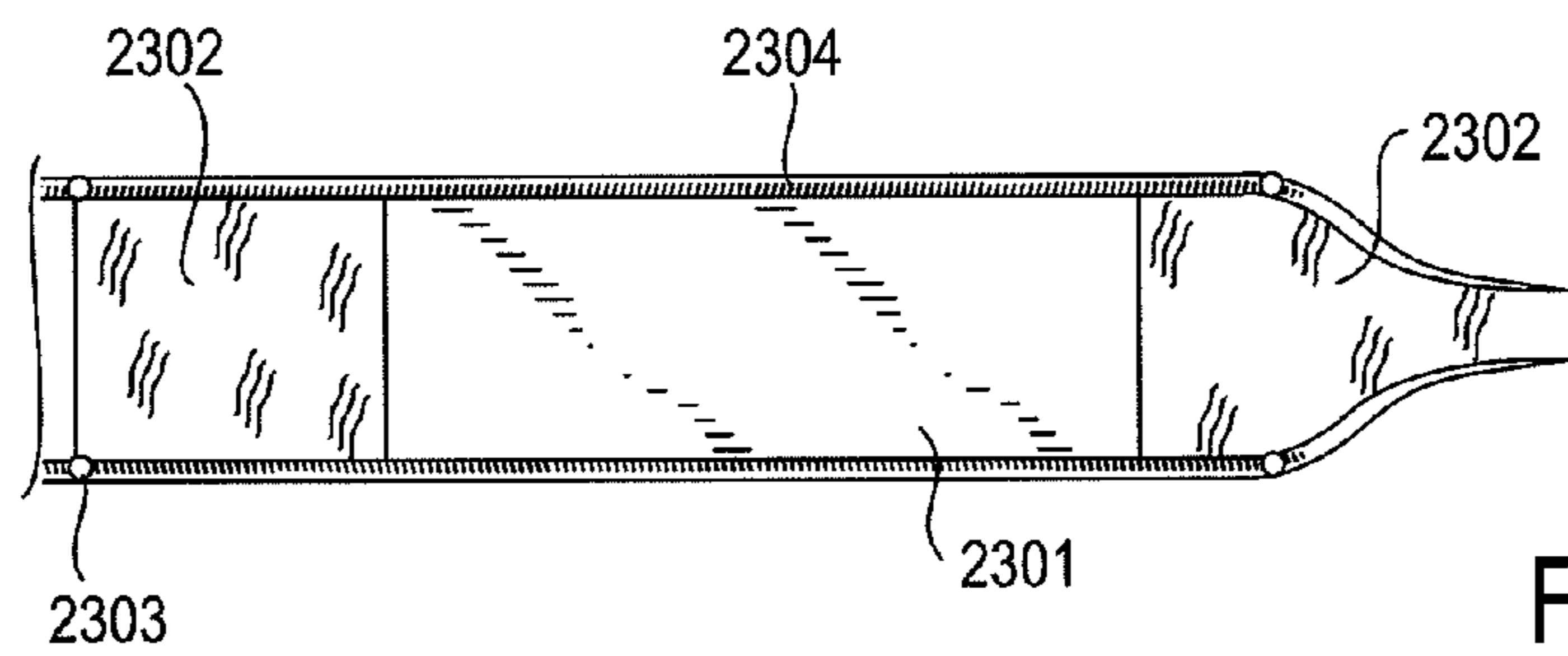

FIG. 23A

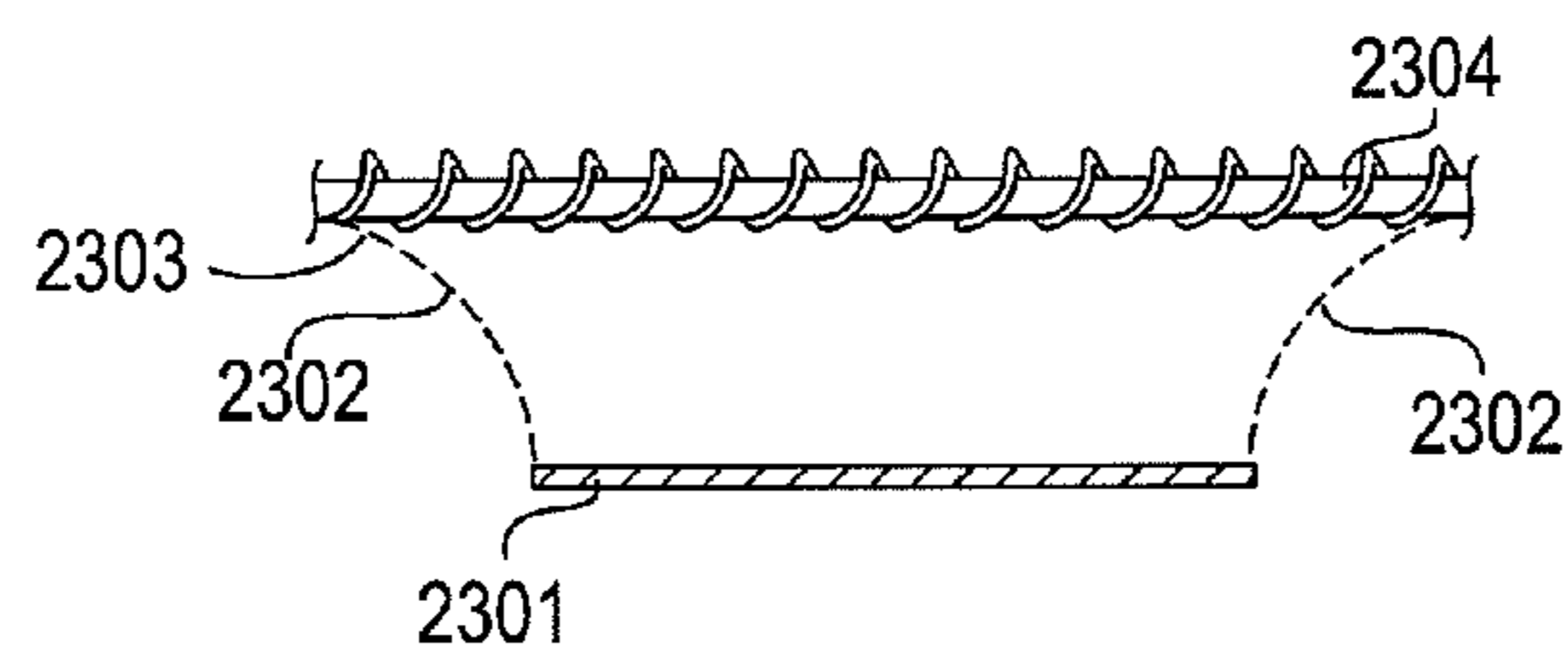

FIG. 23B

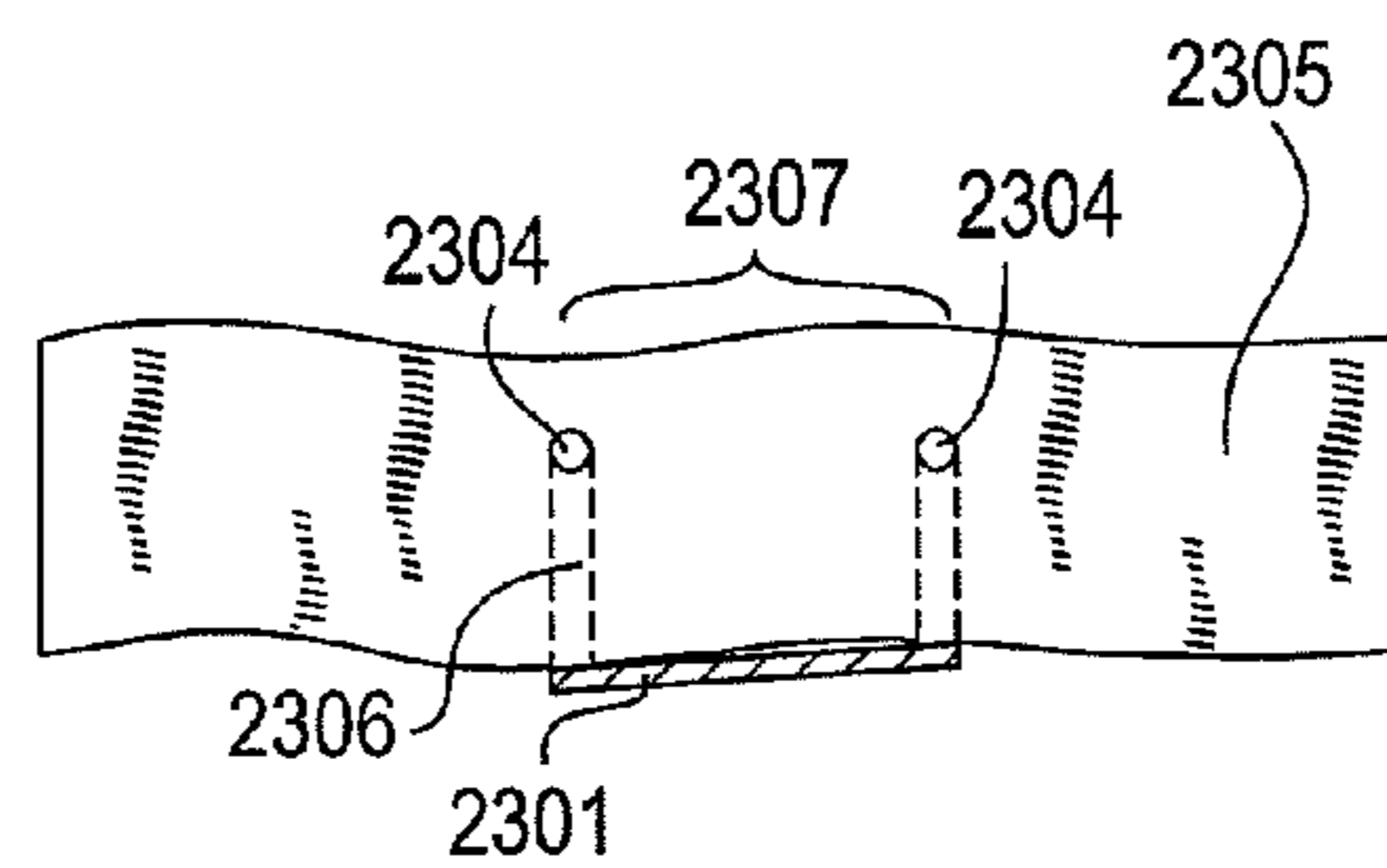

FIG. 23C

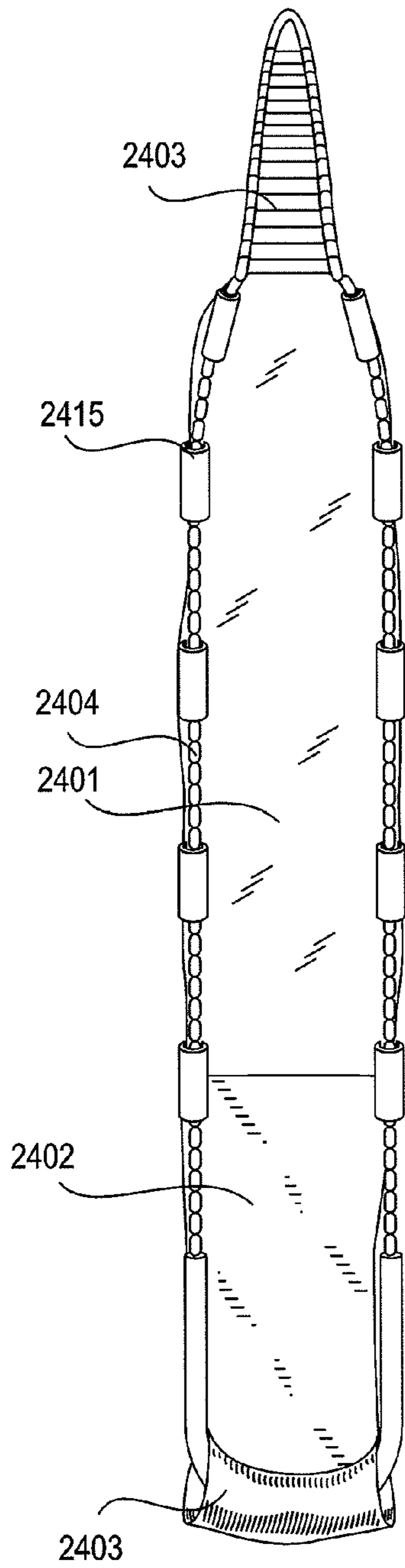

FIG. 24A

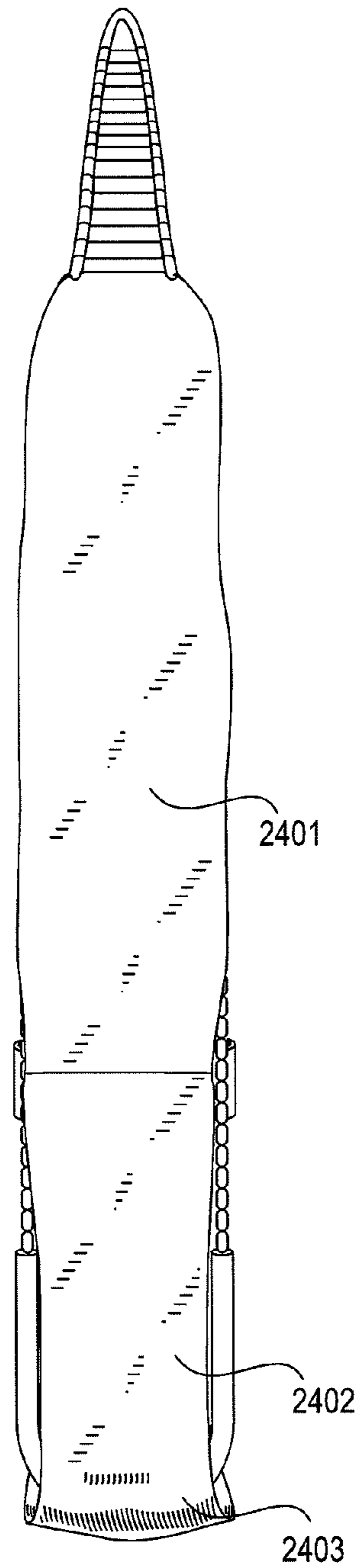

FIG. 24B

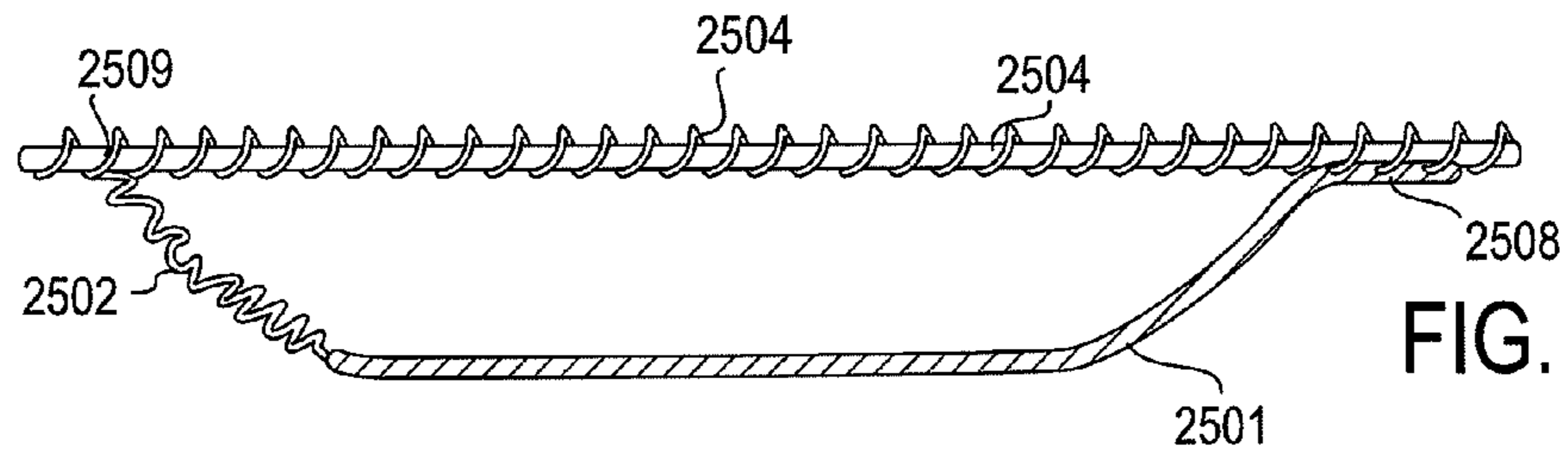

FIG. 25

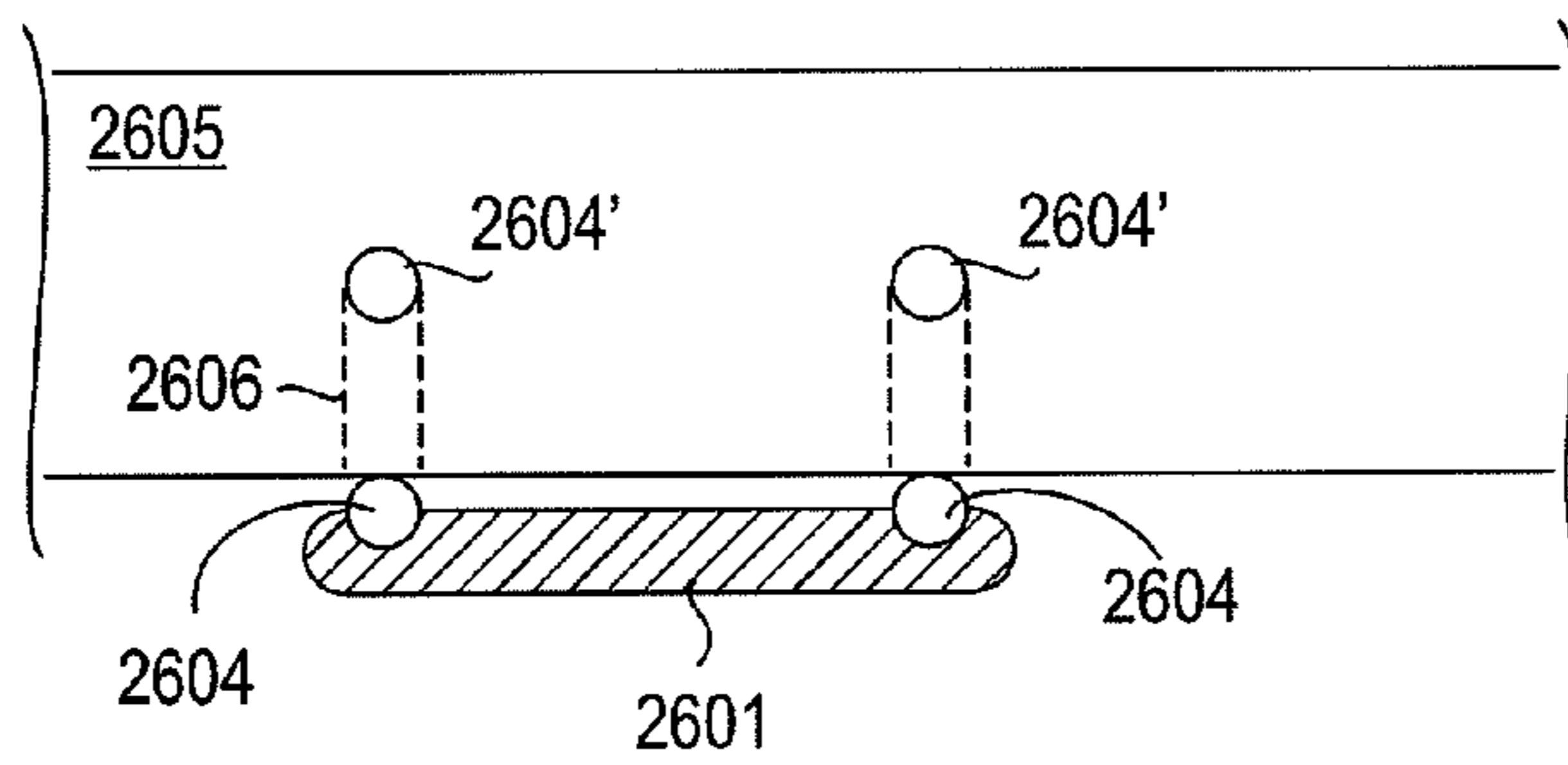

FIG. 26A

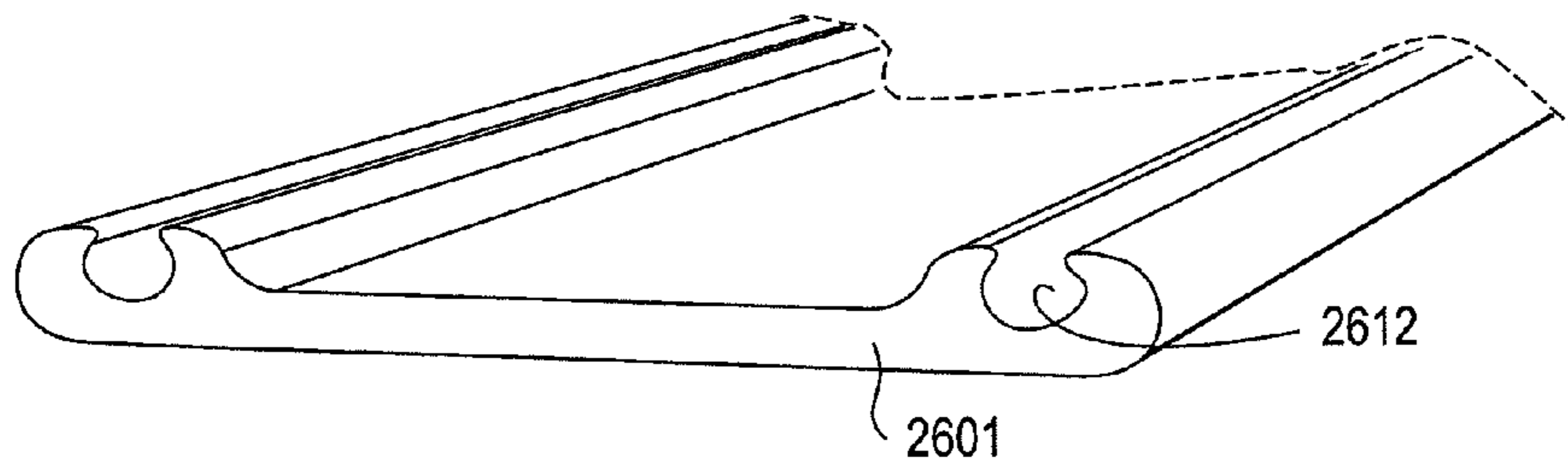

FIG. 26B

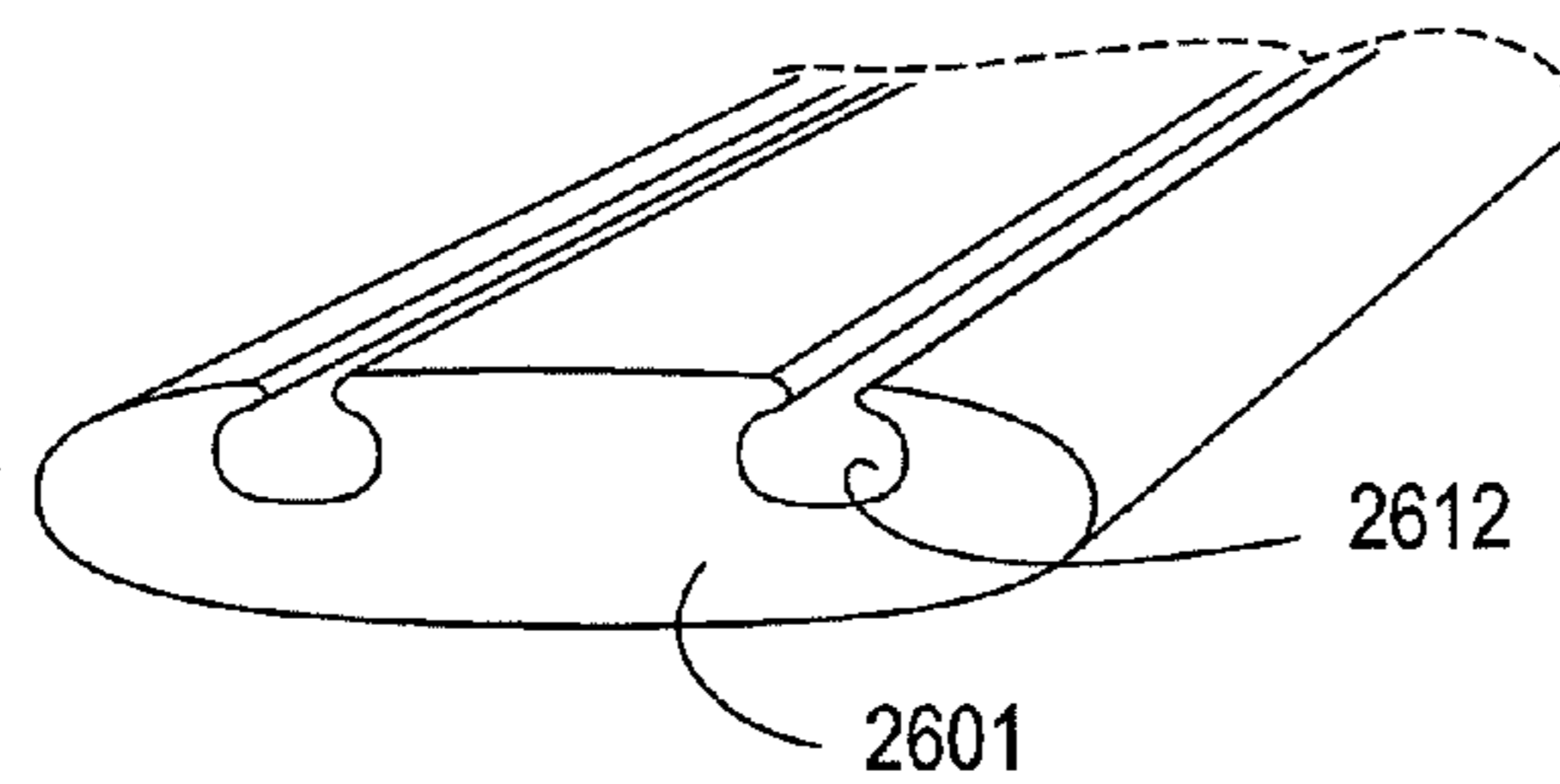

FIG. 26C

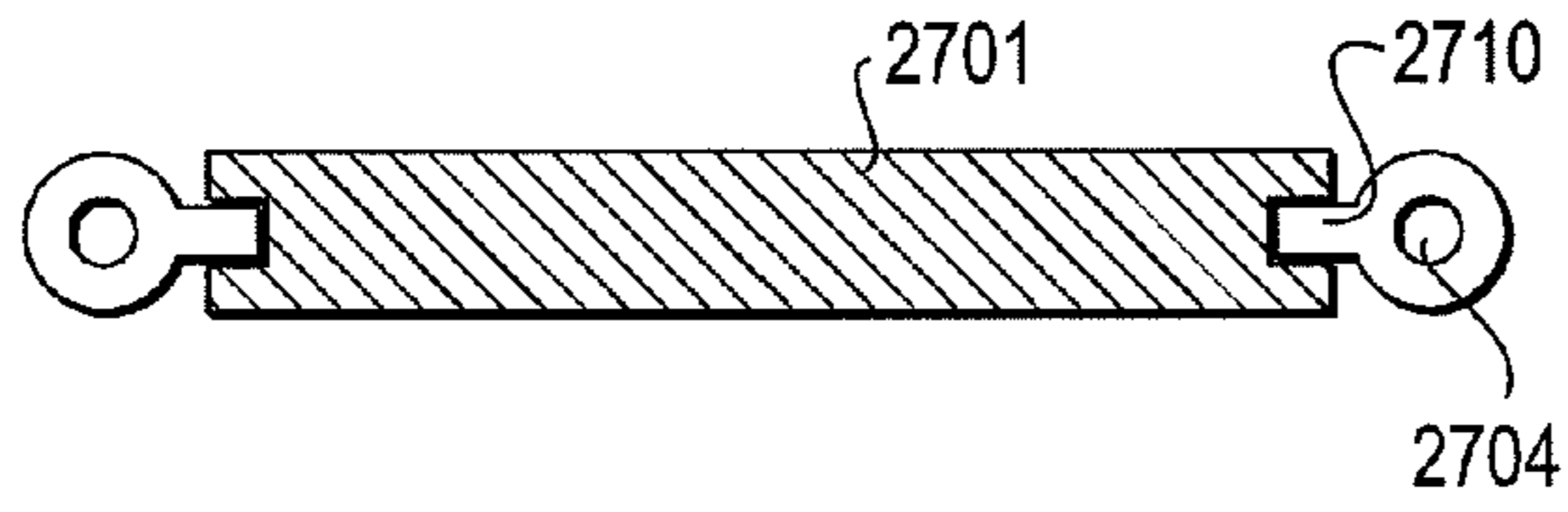

FIG. 27A

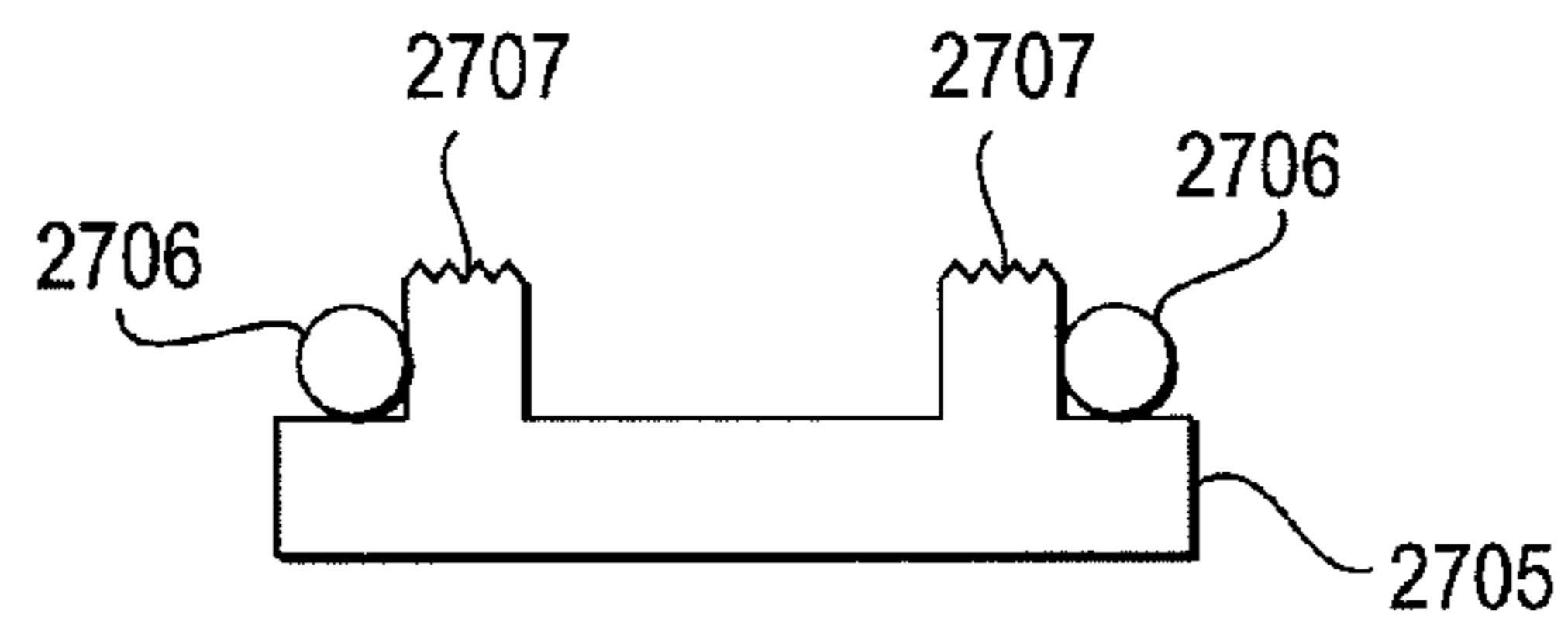

FIG. 27B

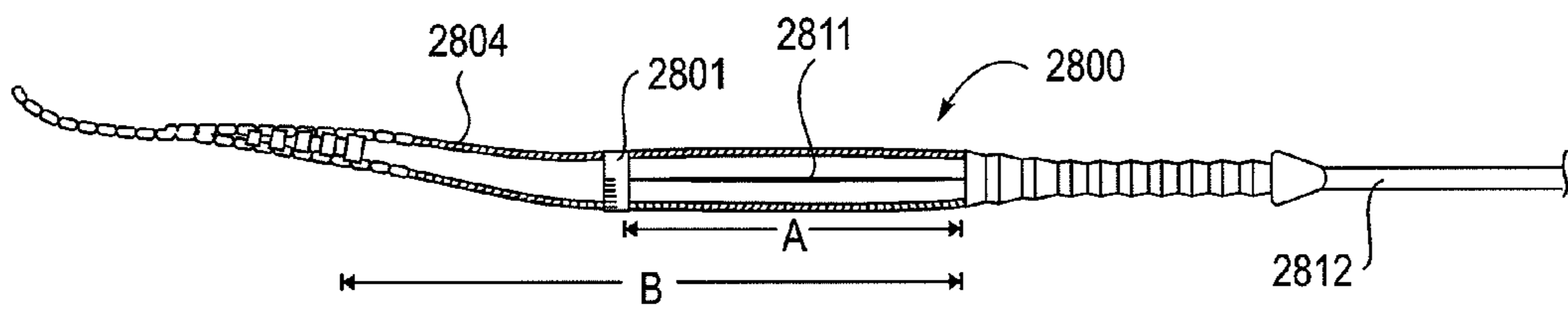

FIG. 28

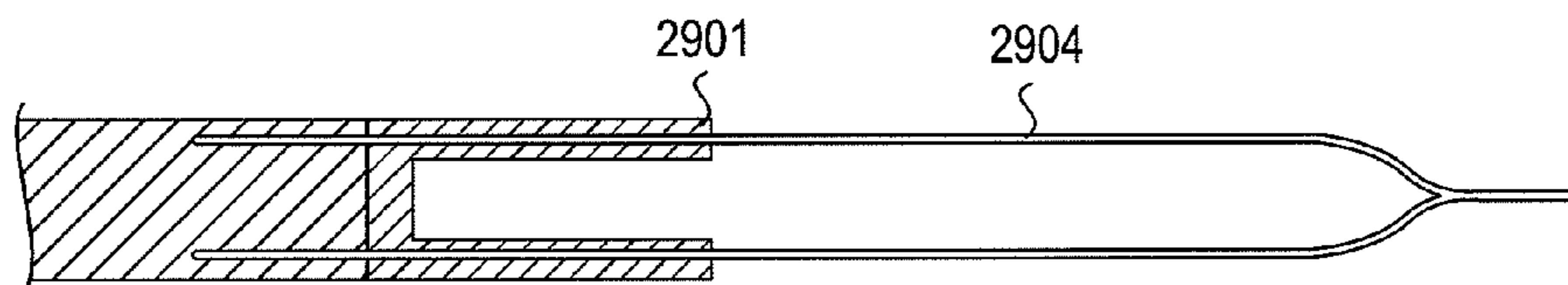

FIG. 29

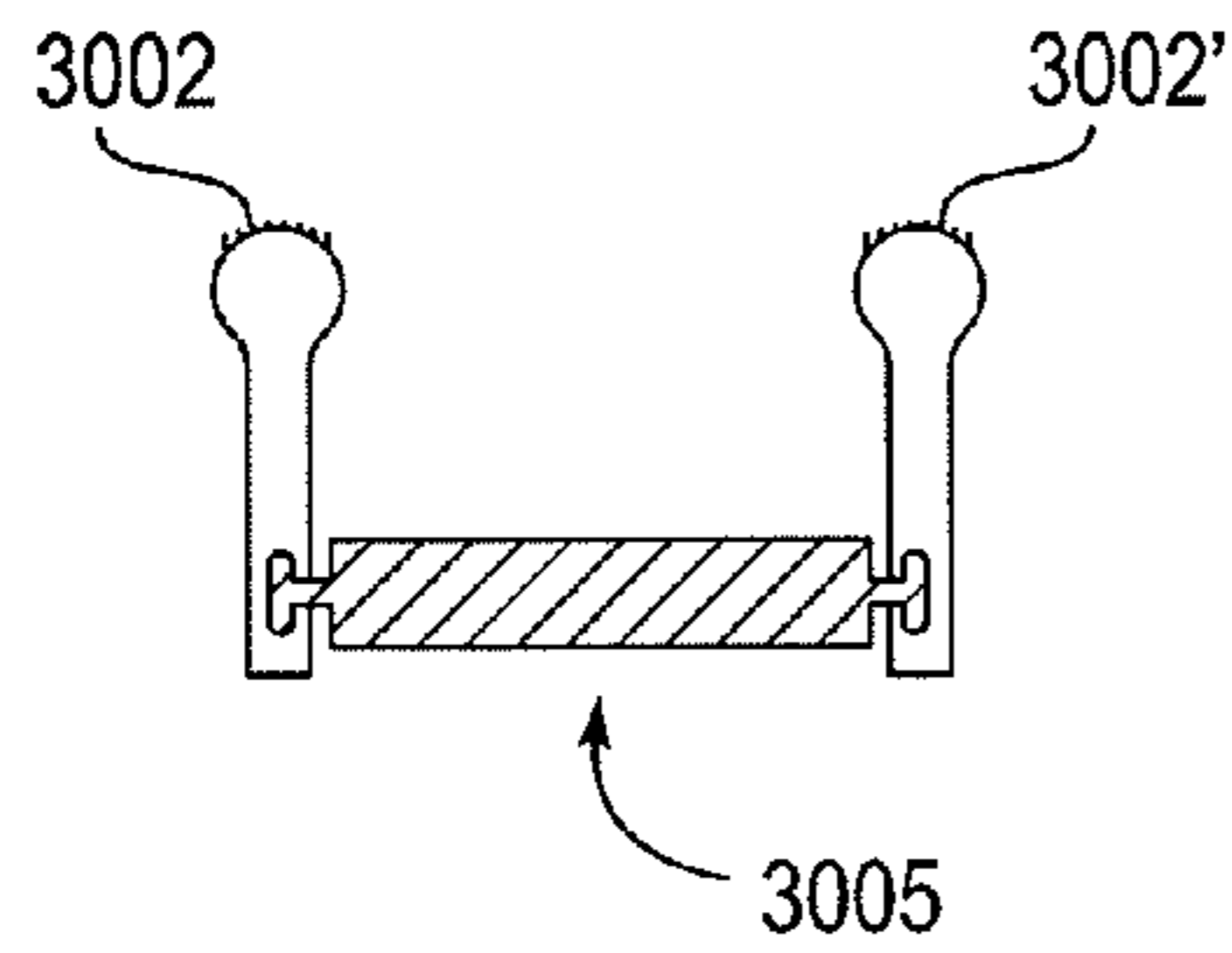

FIG. 30A

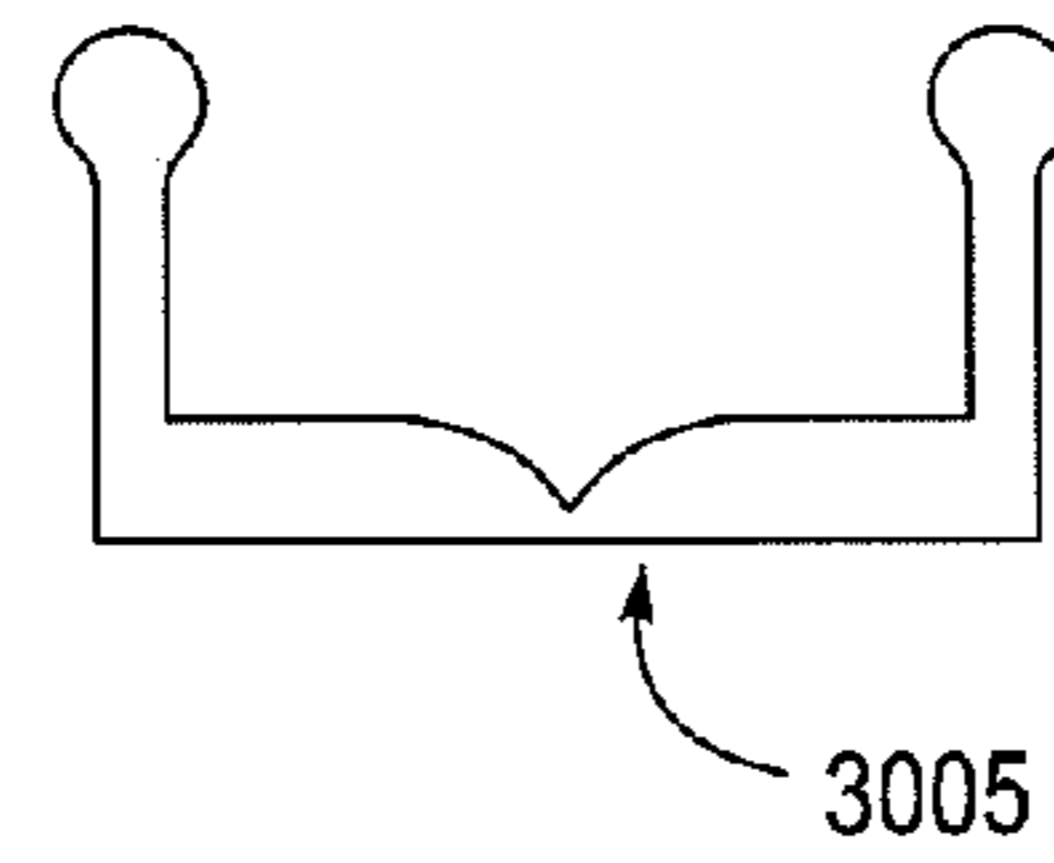

FIG. 30B

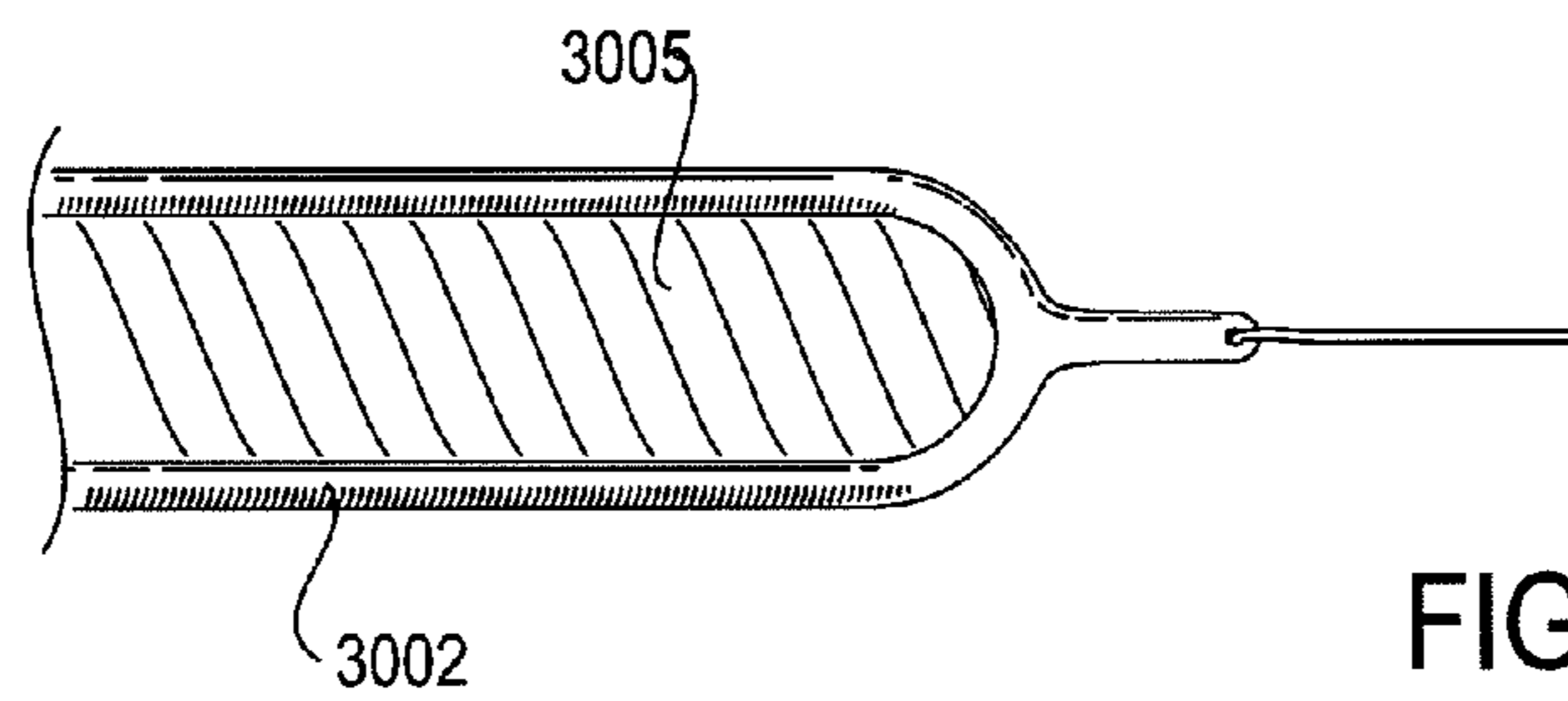

FIG. 30C

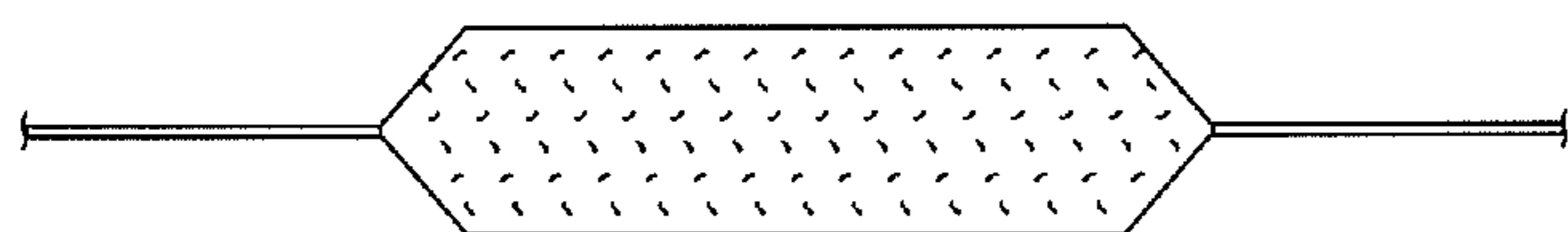

FIG. 31A



FIG. 31B

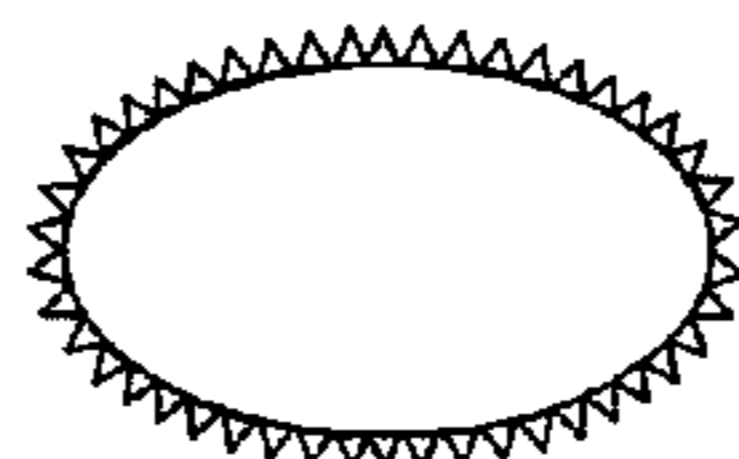

FIG. 31C



FIG. 31D

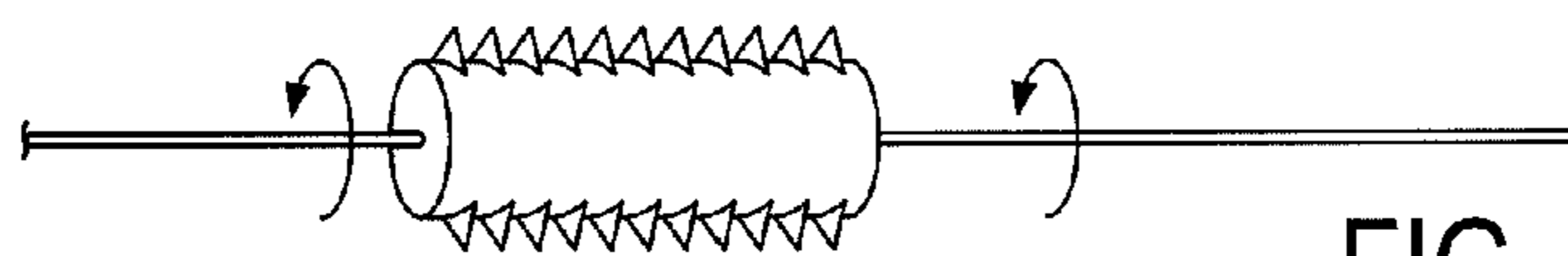
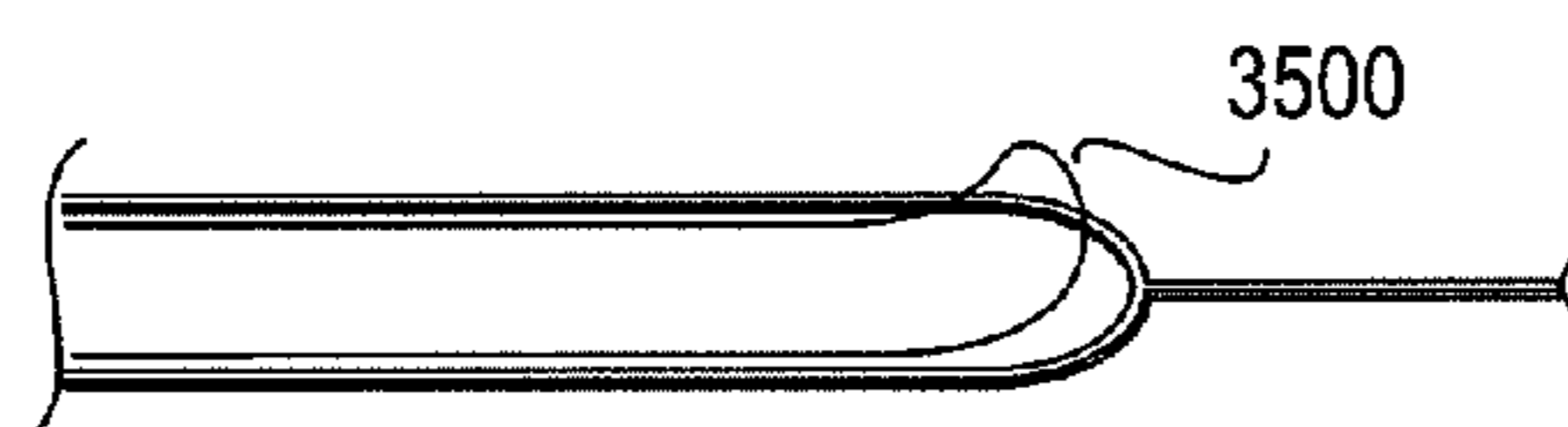
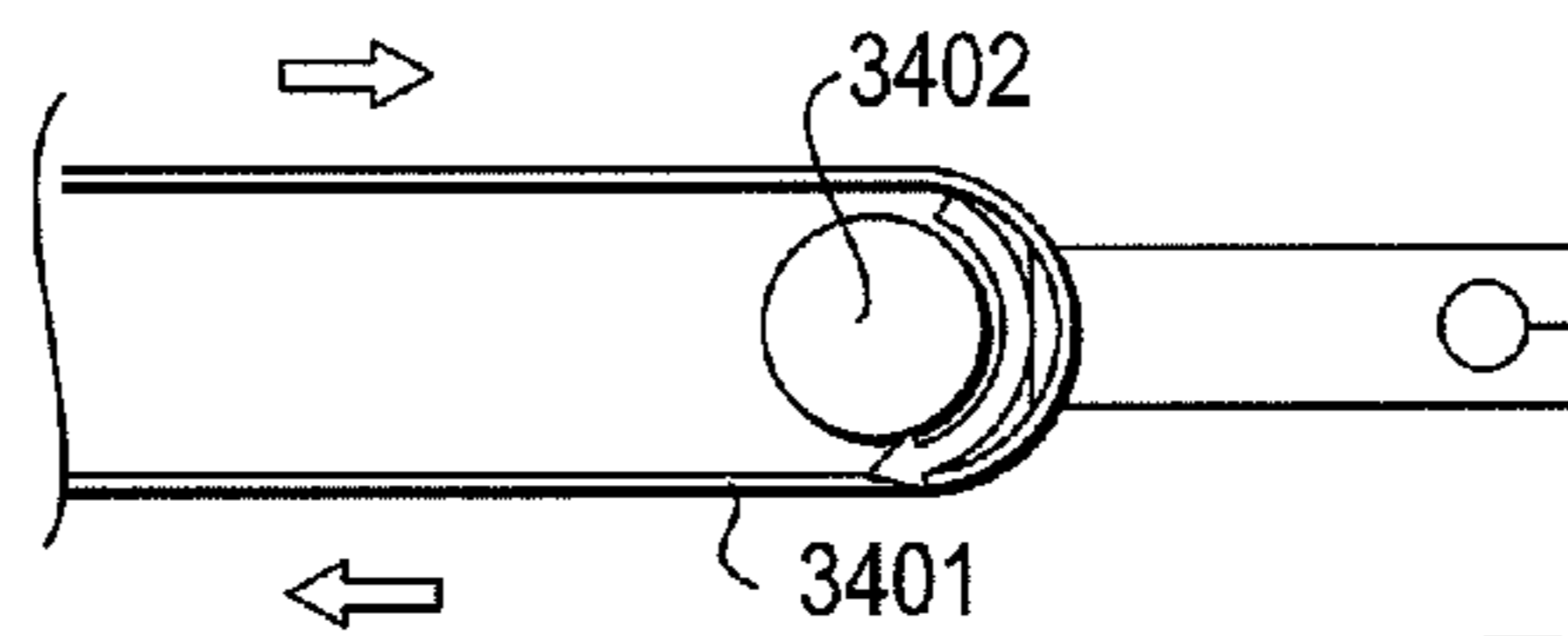
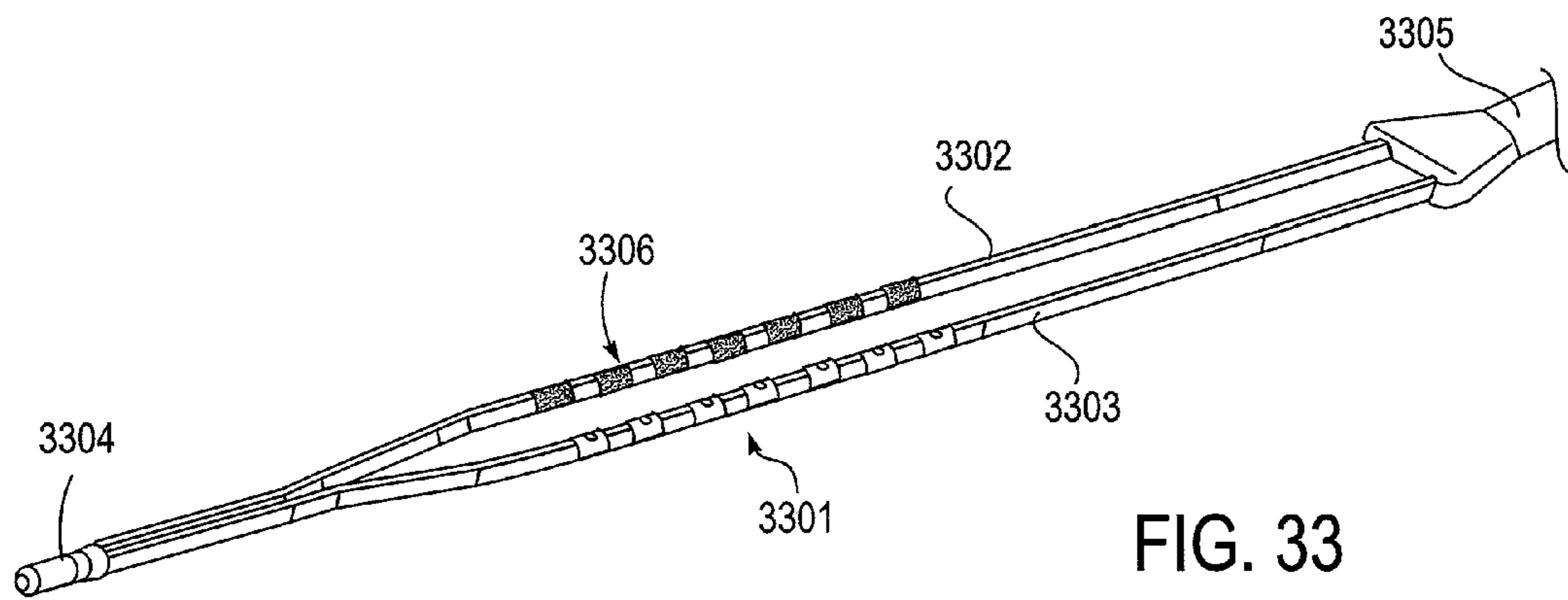
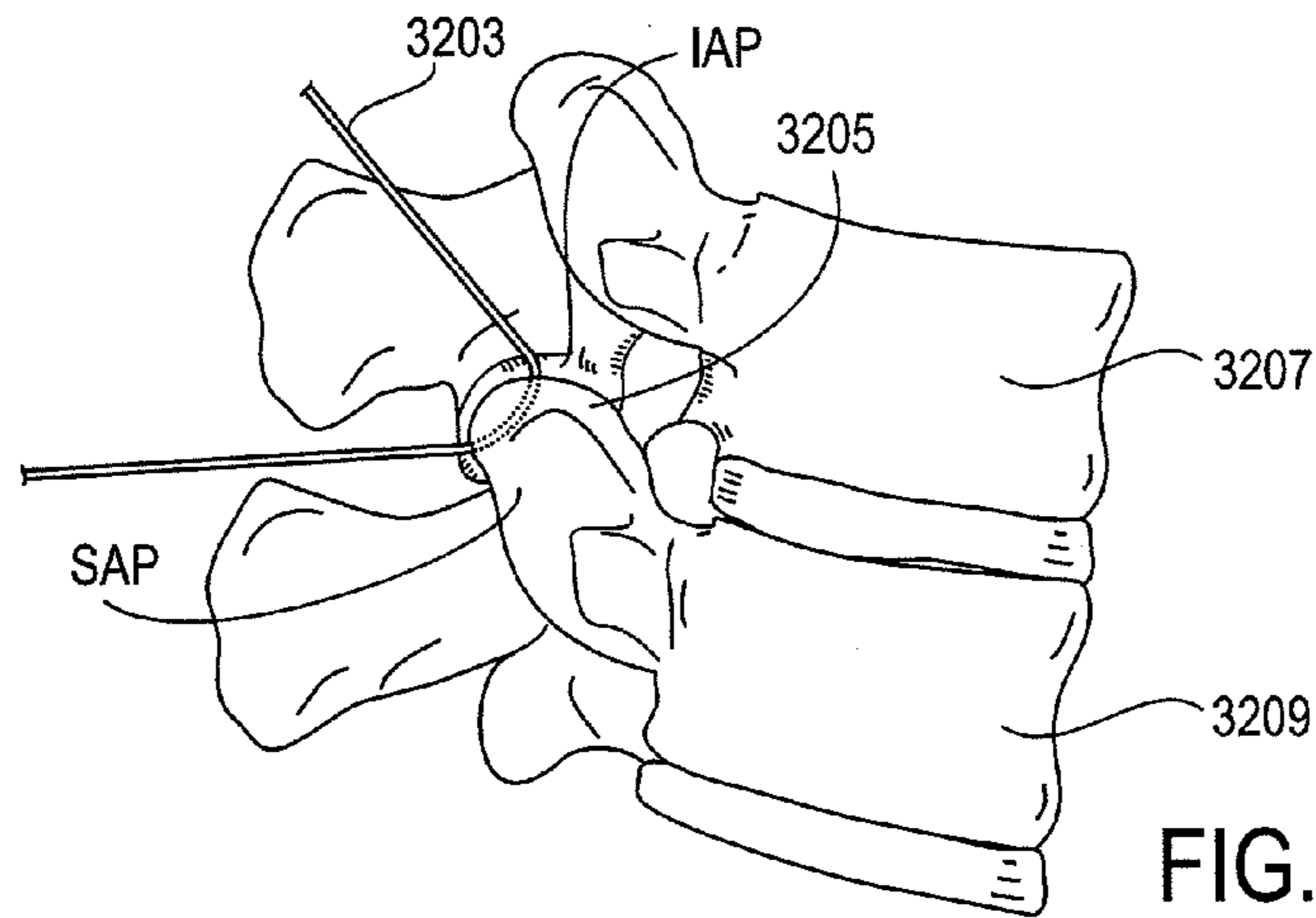

FIG. 31E



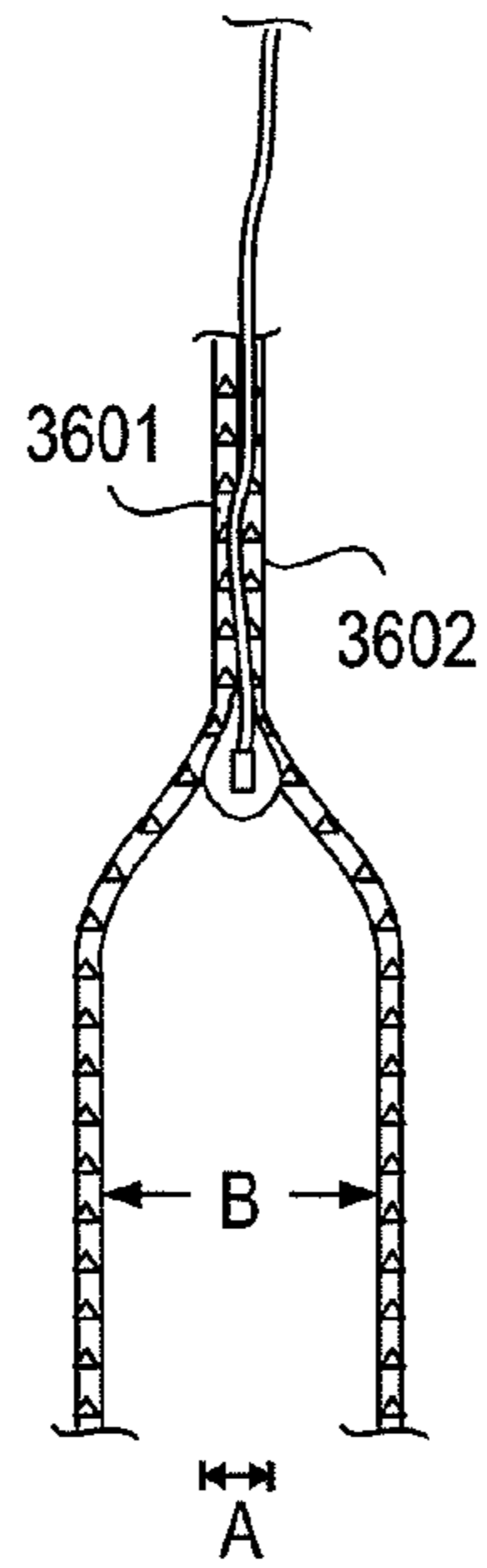

FIG. 36

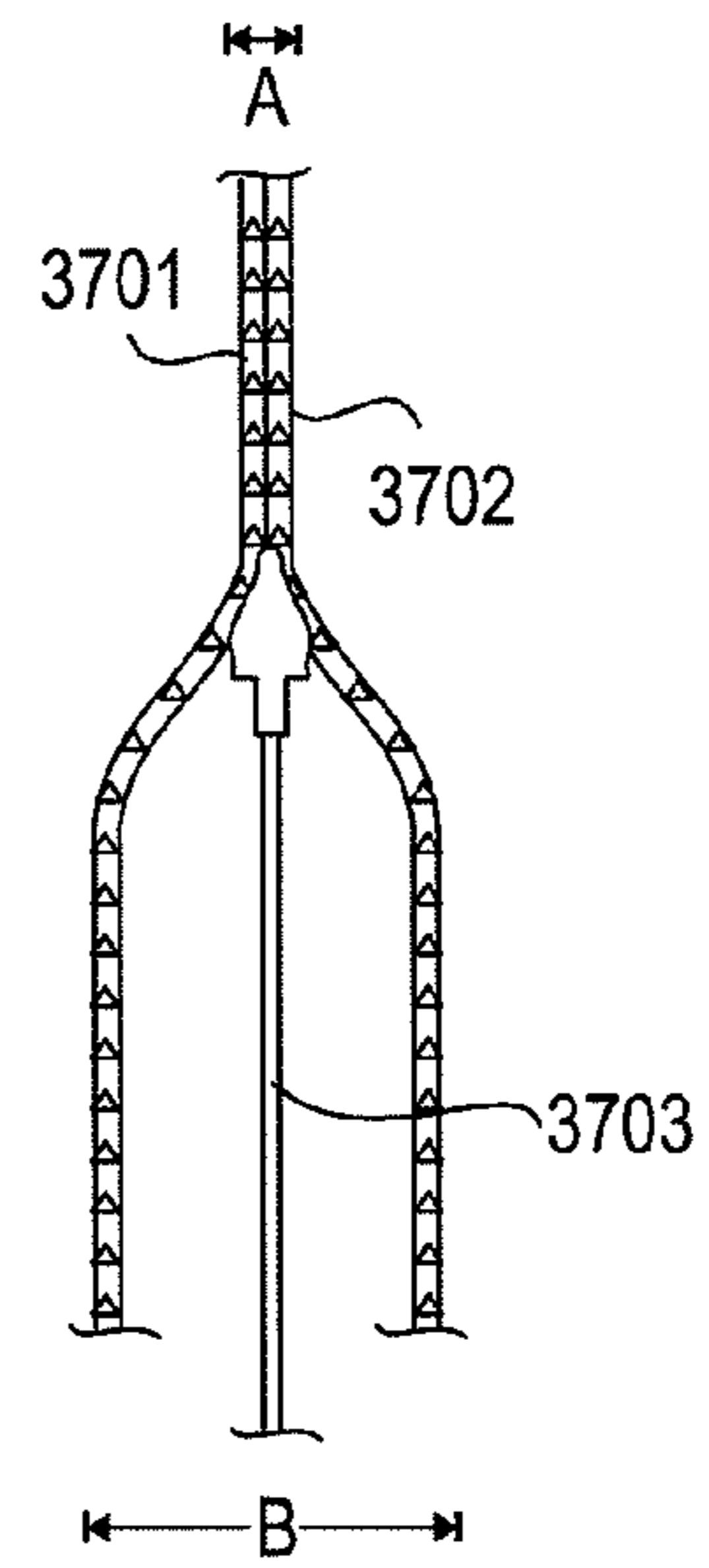

FIG. 37

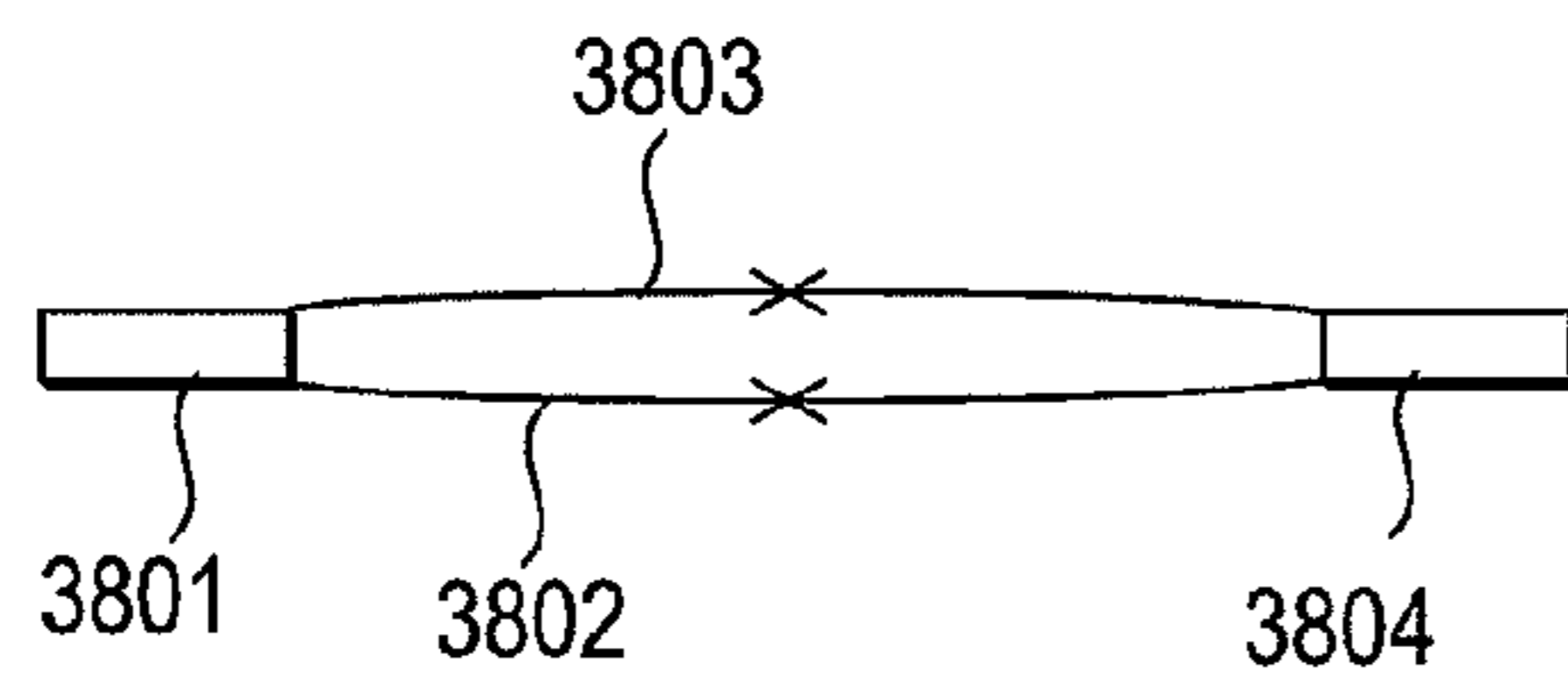

FIG. 38A

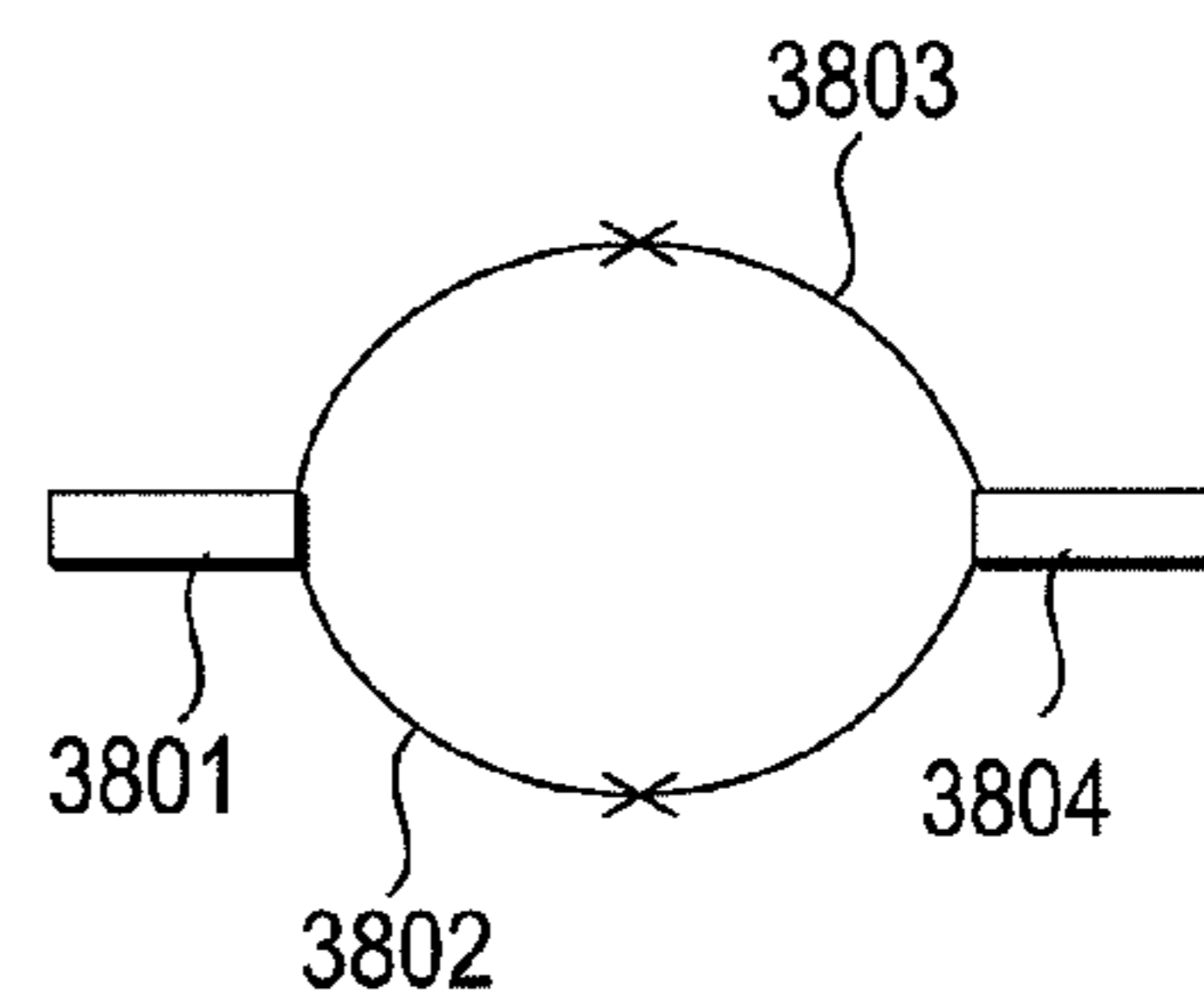

FIG. 38B

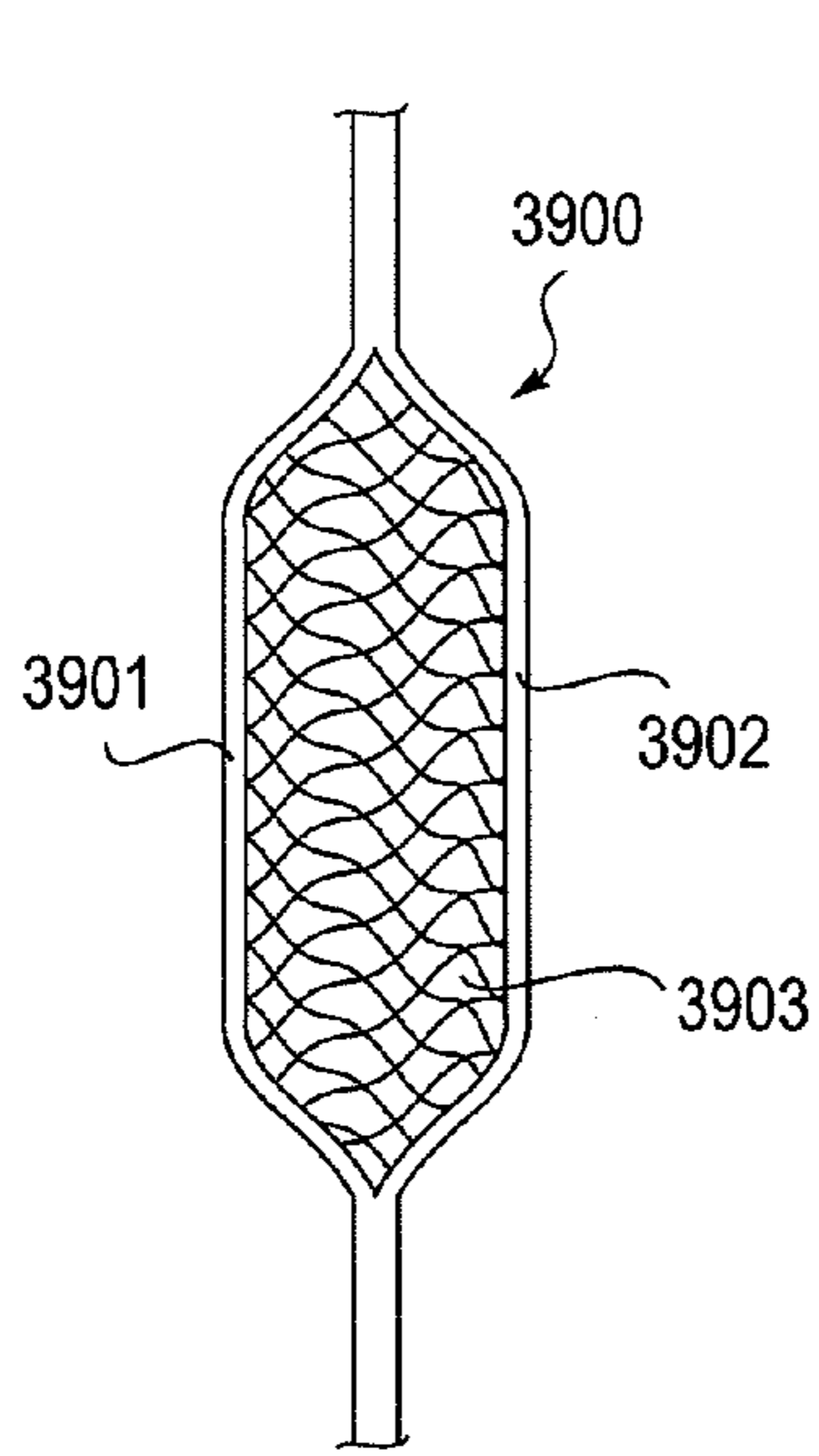

FIG. 39

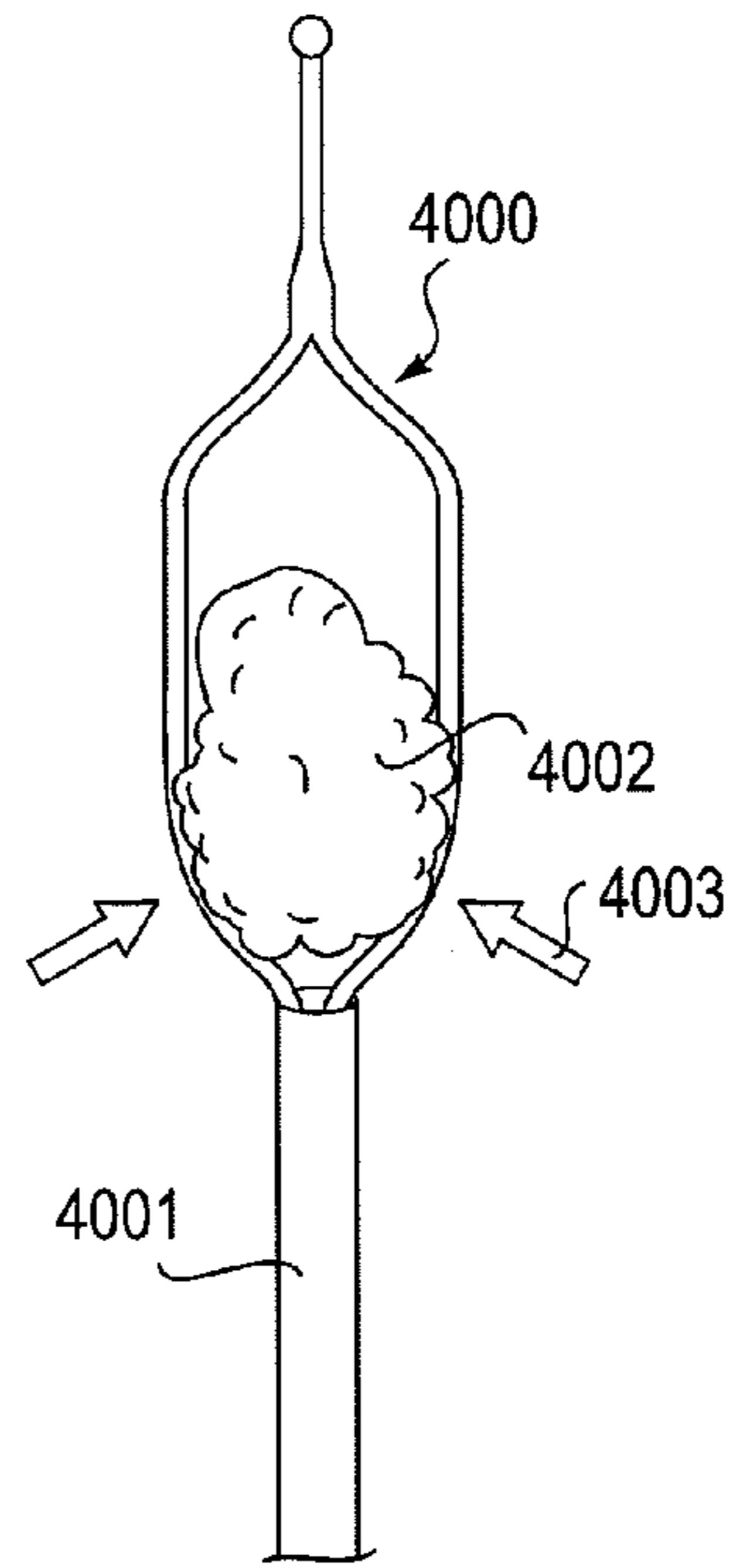

FIG. 40

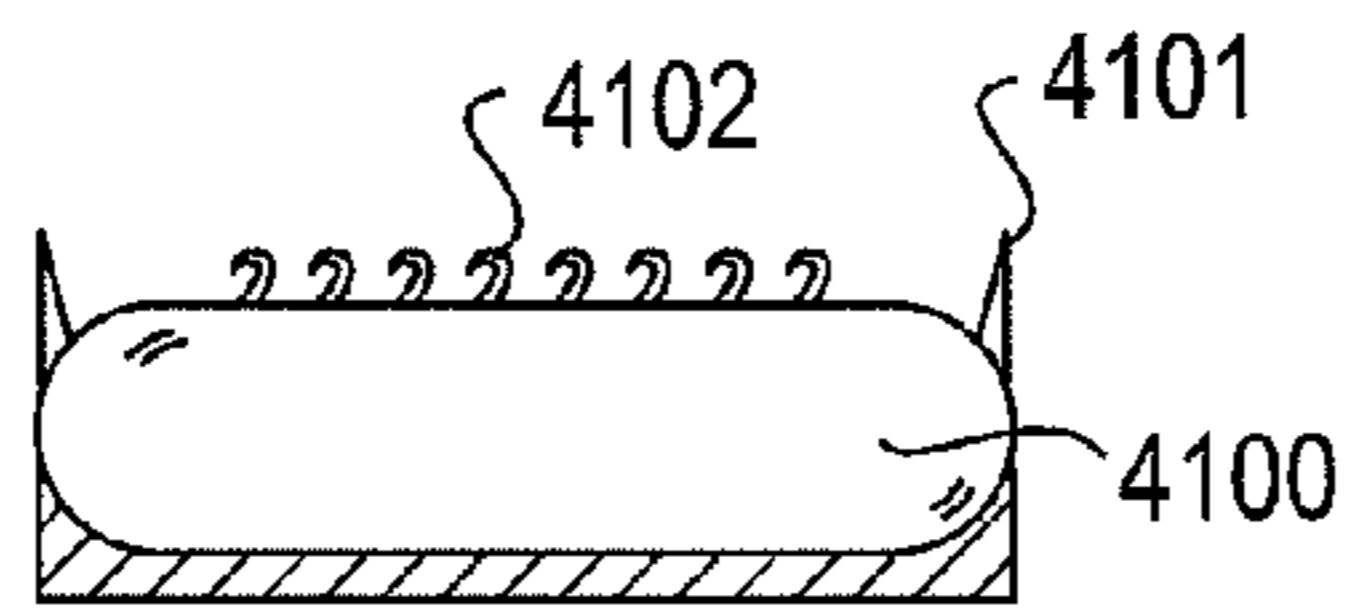

FIG. 41A

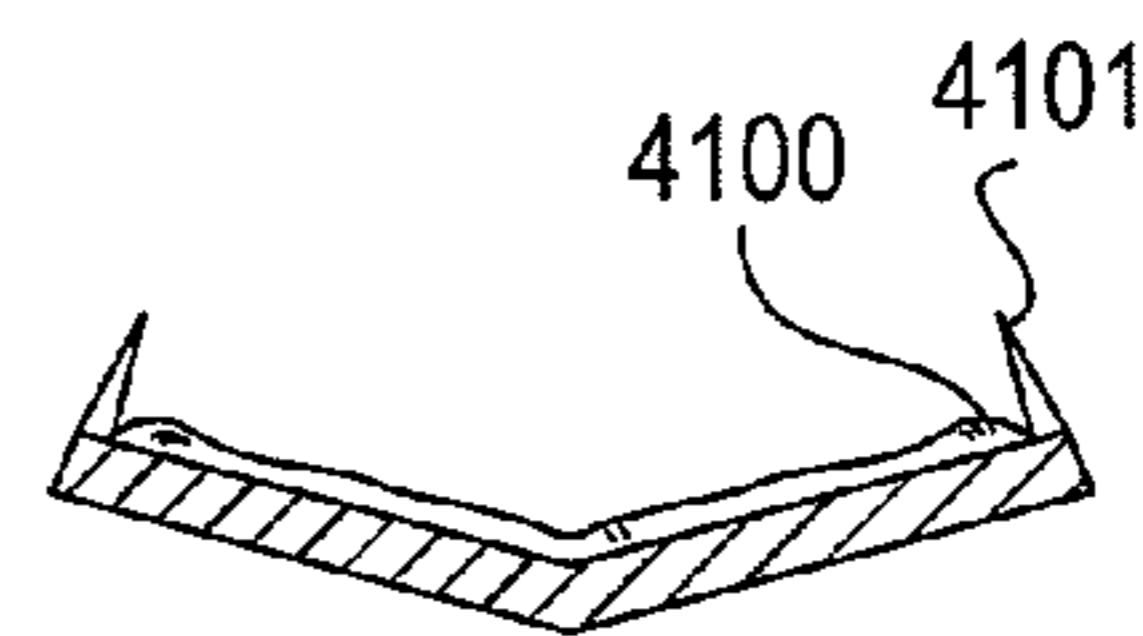

FIG. 41B

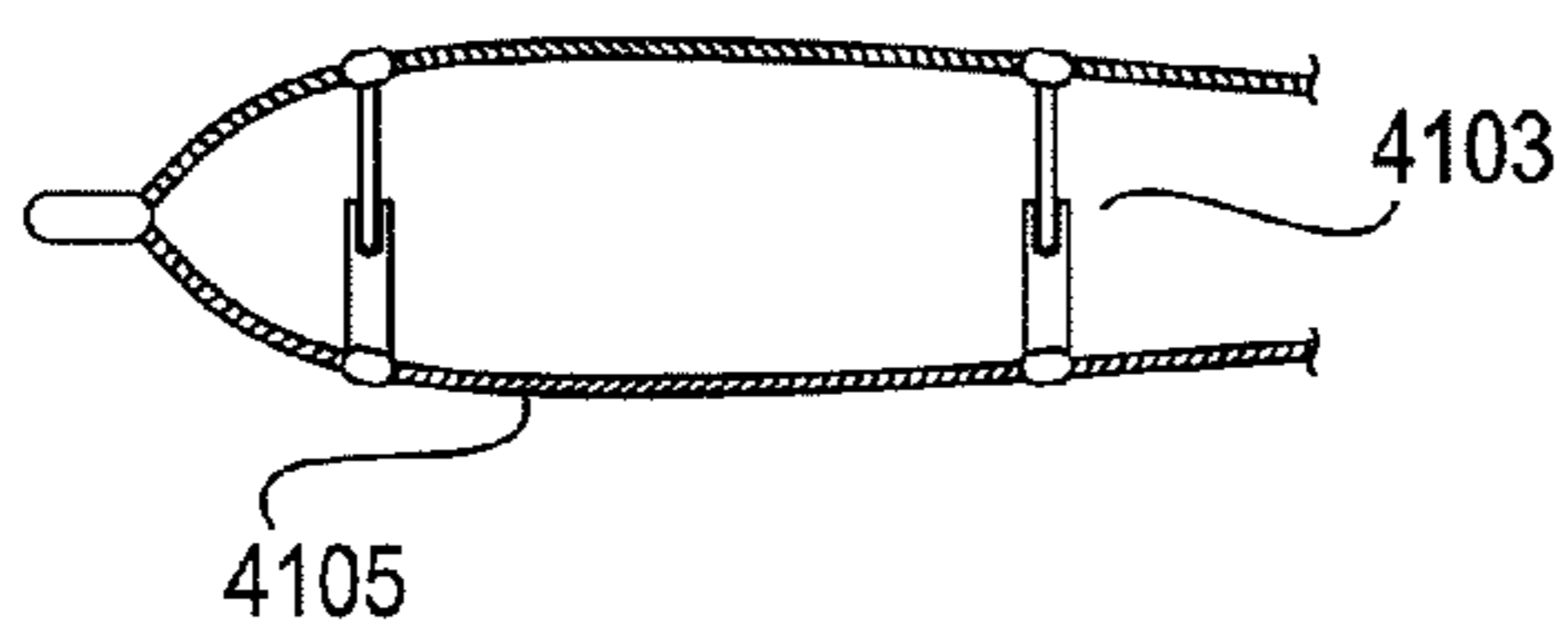

FIG. 41C

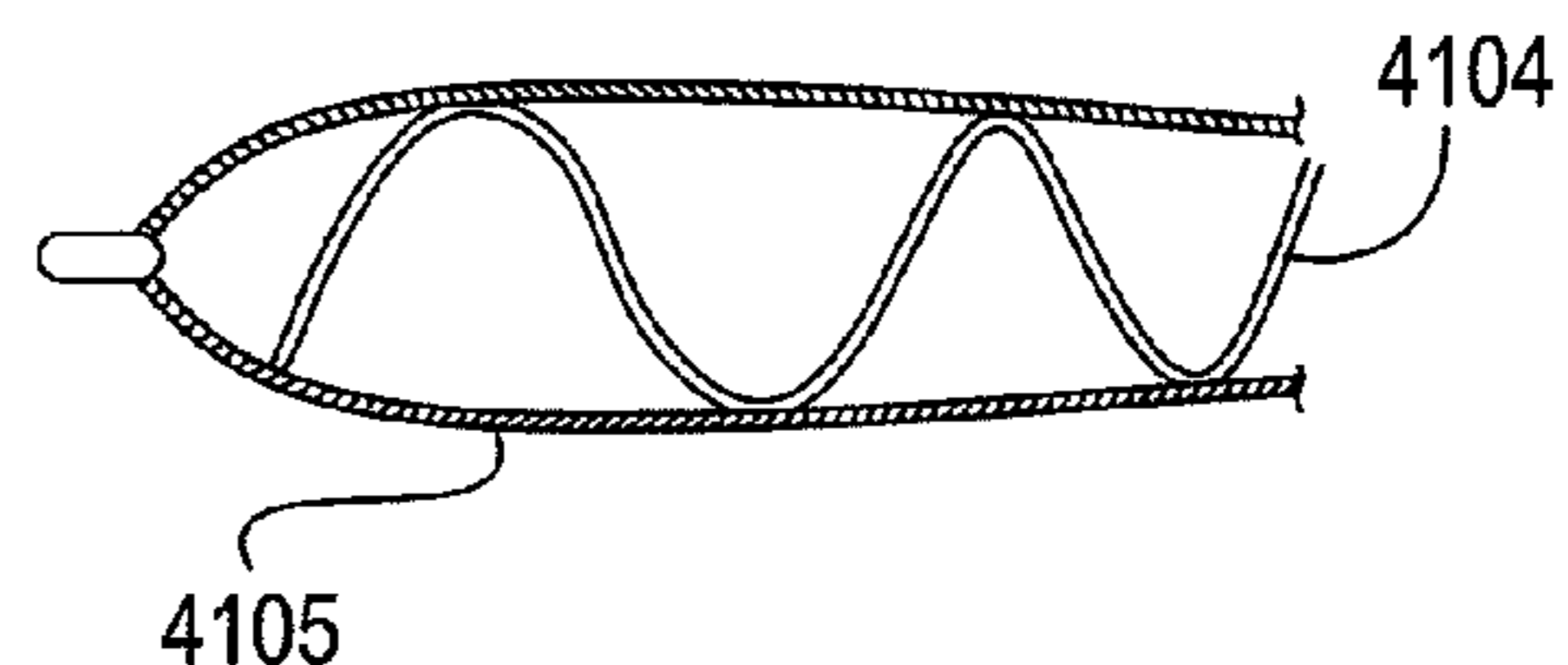

FIG. 41D

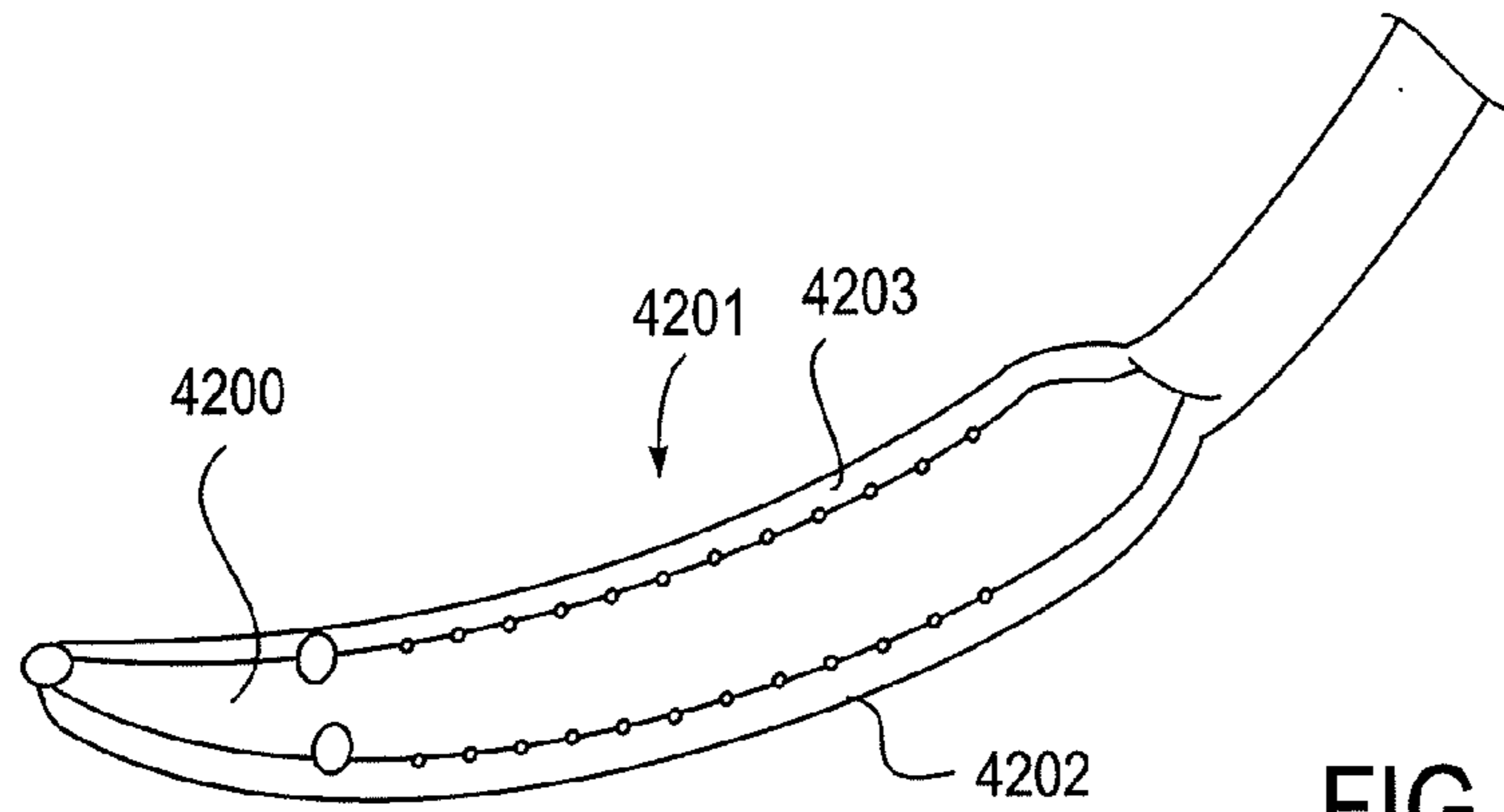

FIG. 42

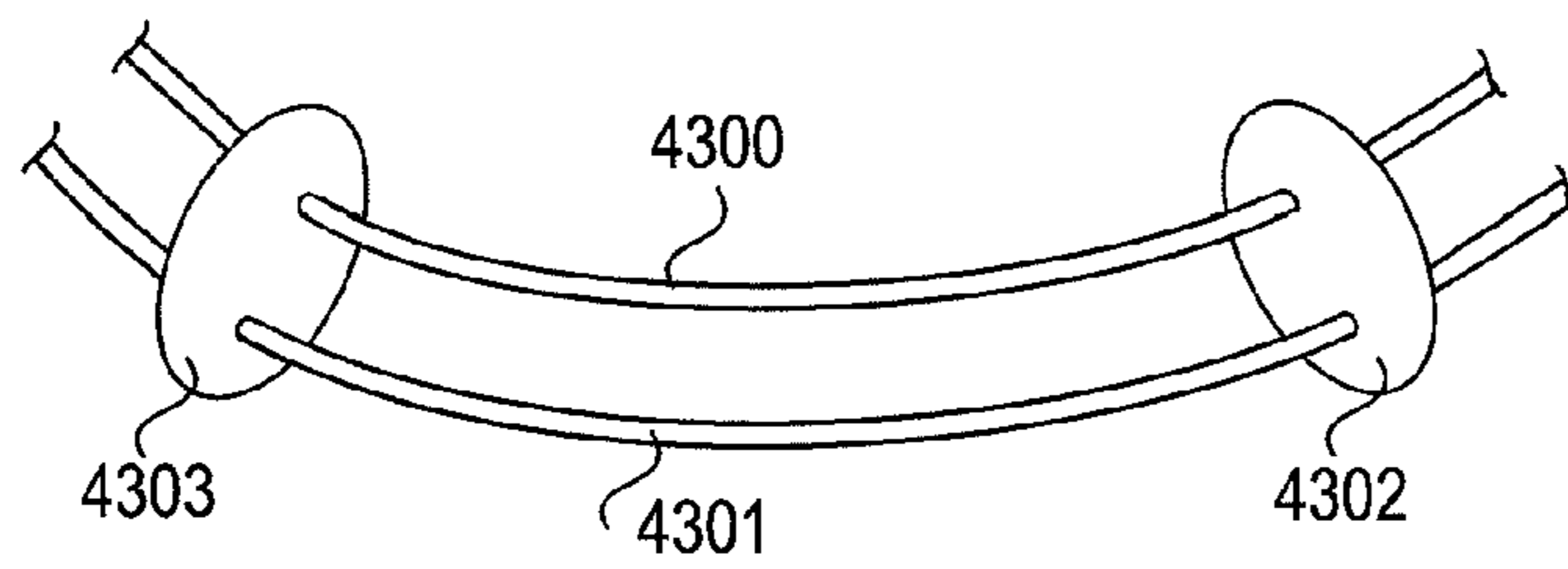

FIG. 43

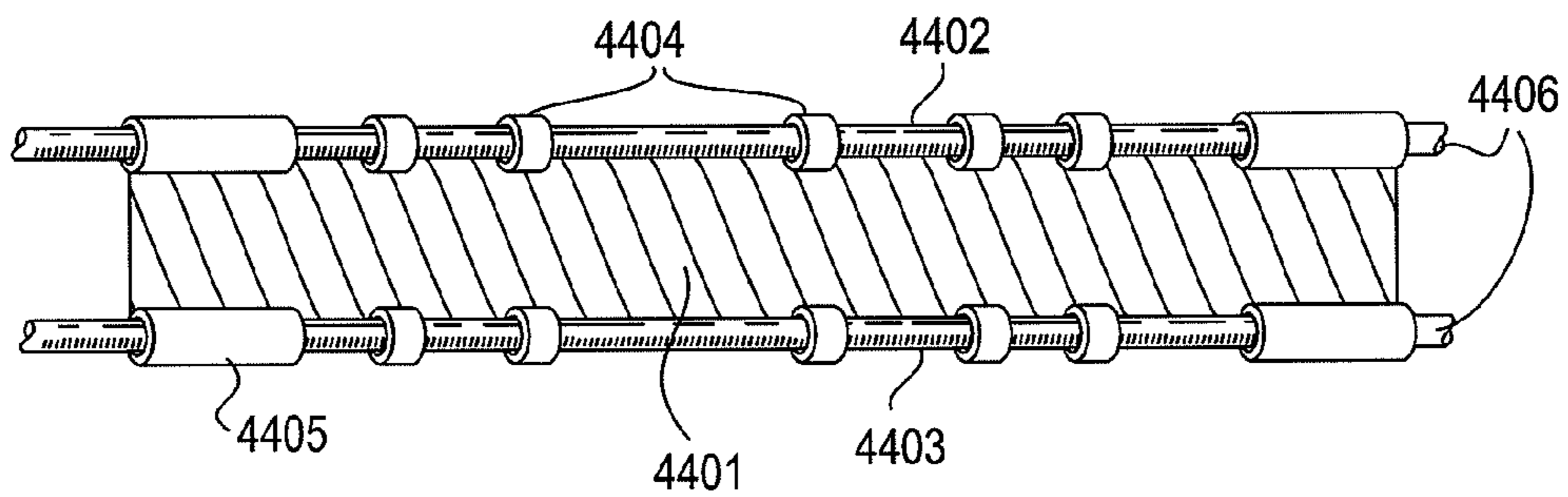

FIG. 44

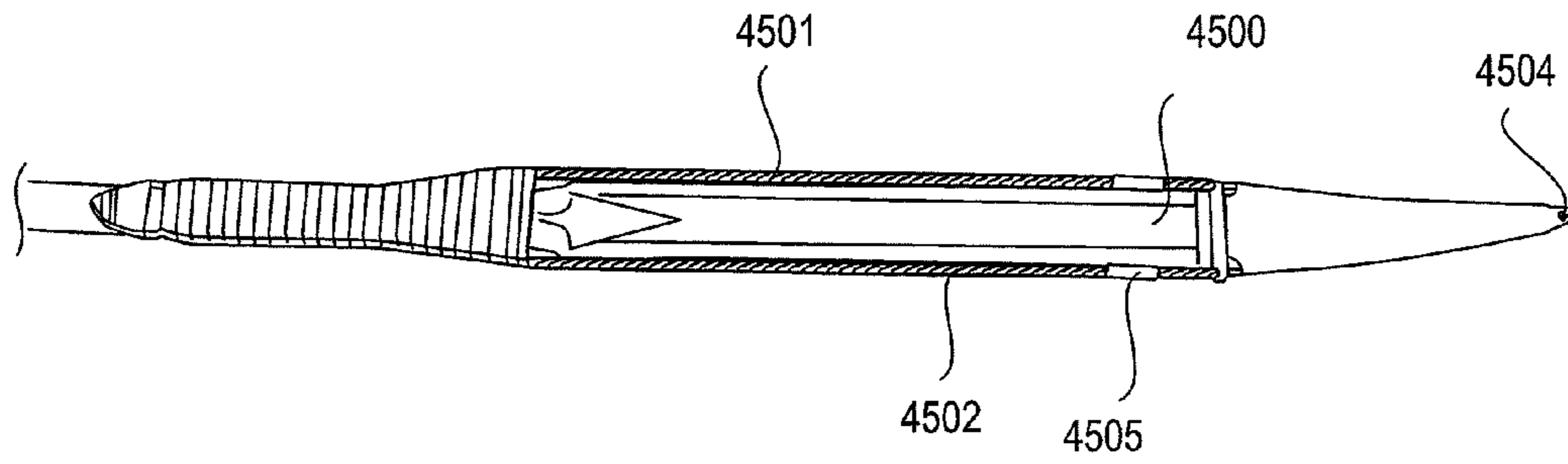

FIG. 45A

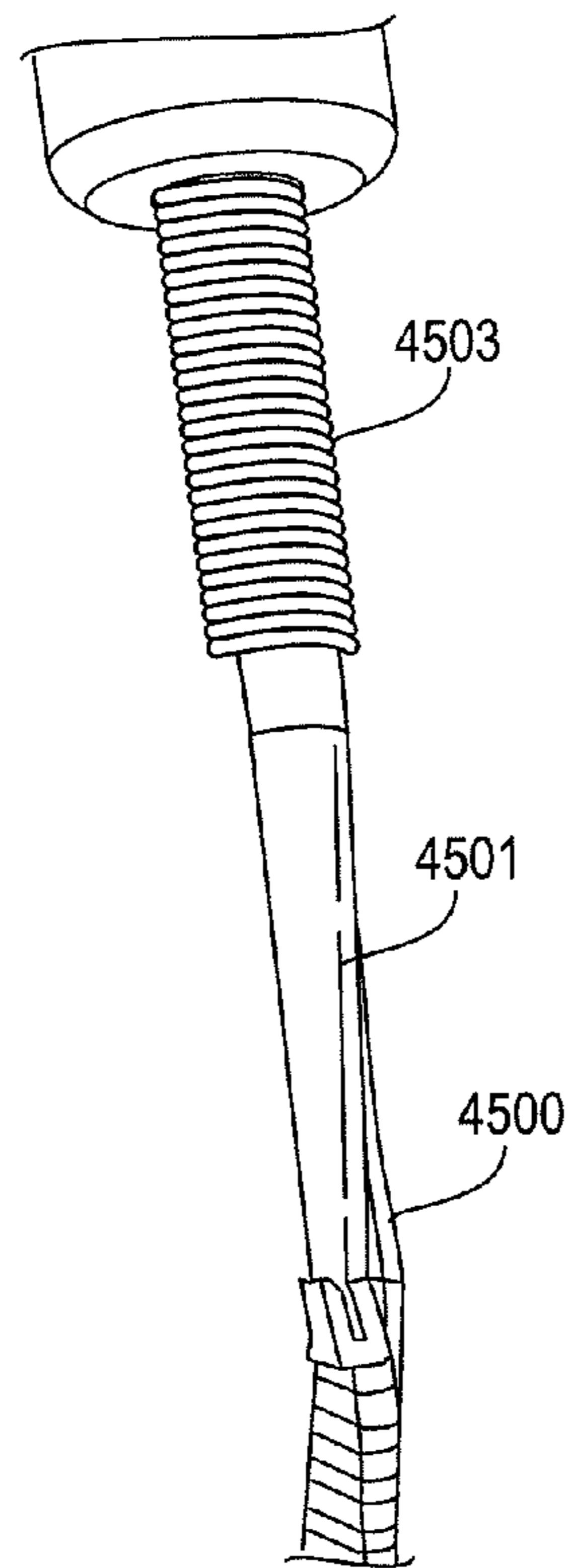

FIG. 45B

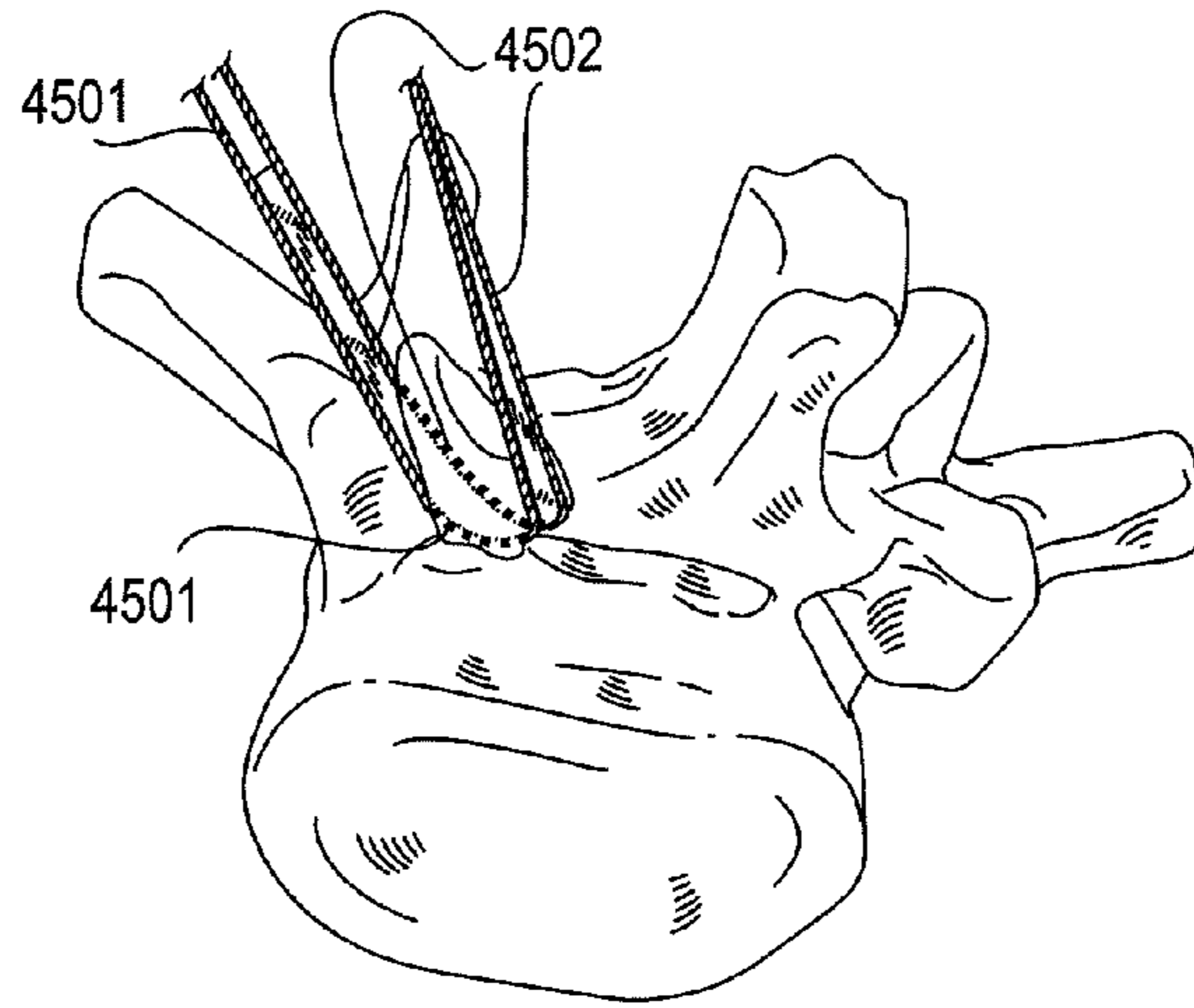

FIG. 46A

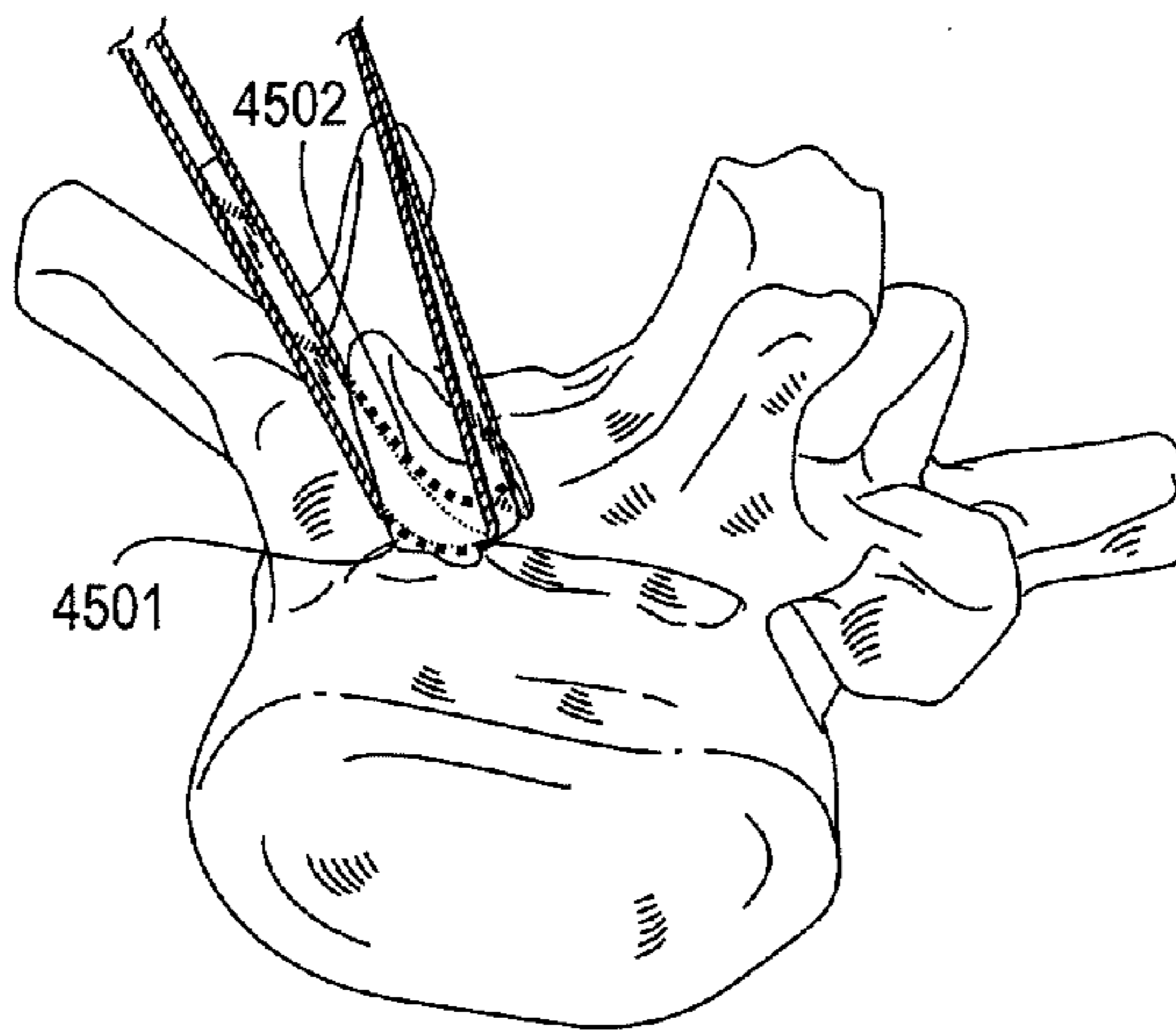

FIG. 46B

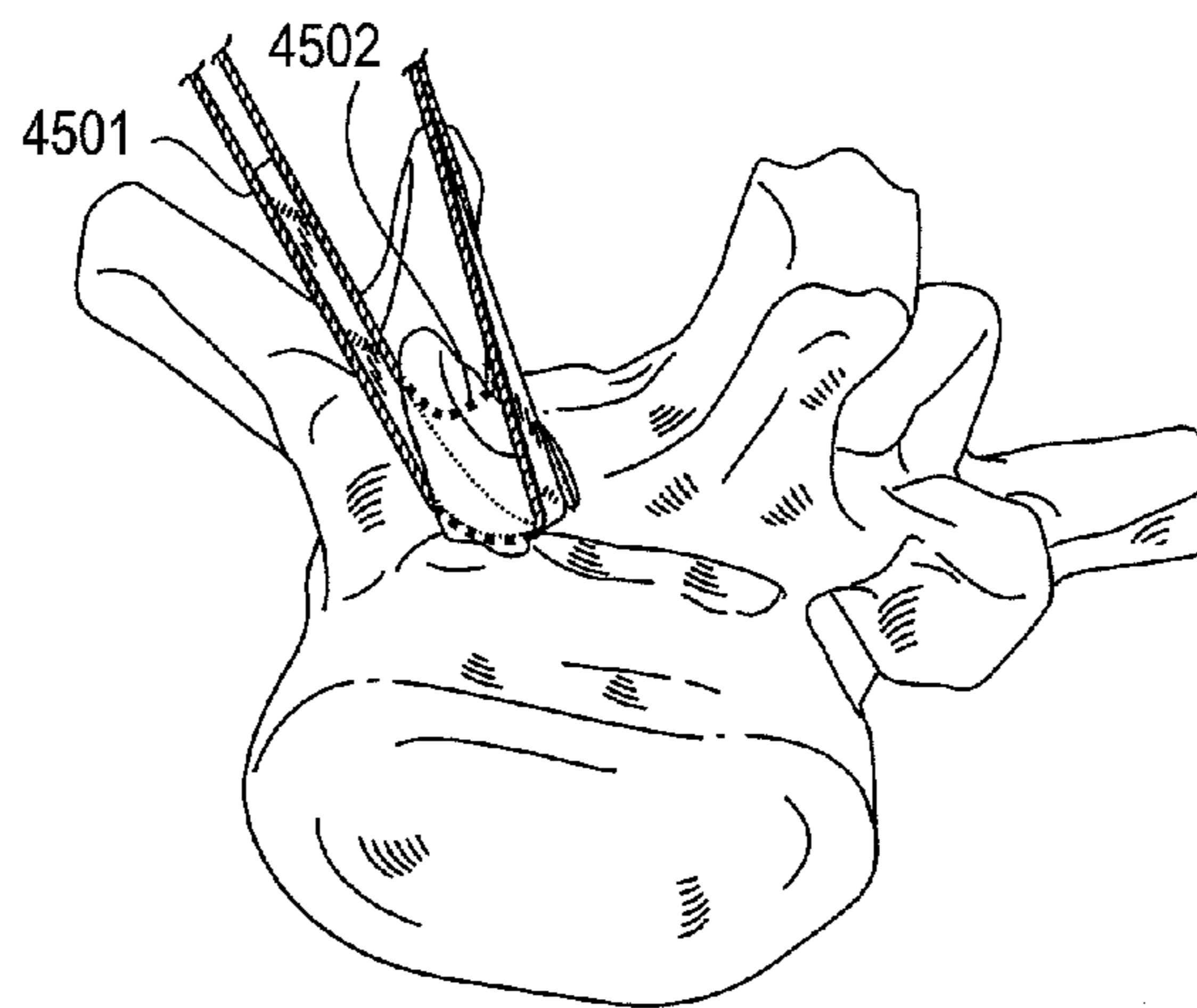

FIG. 46C

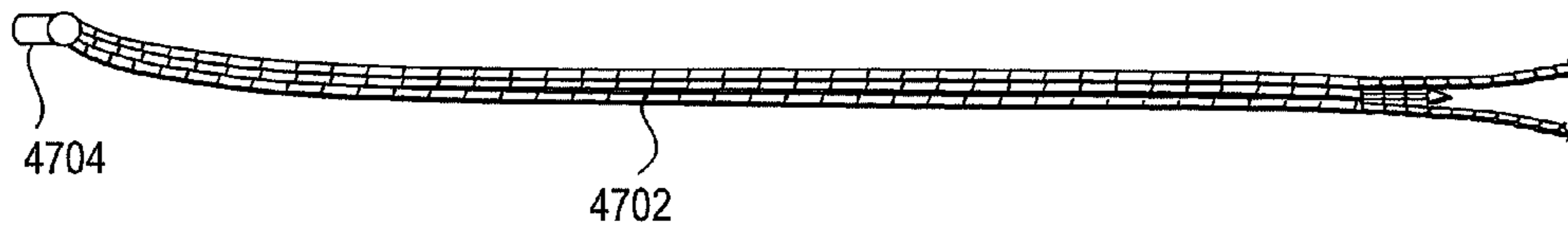

FIG. 47

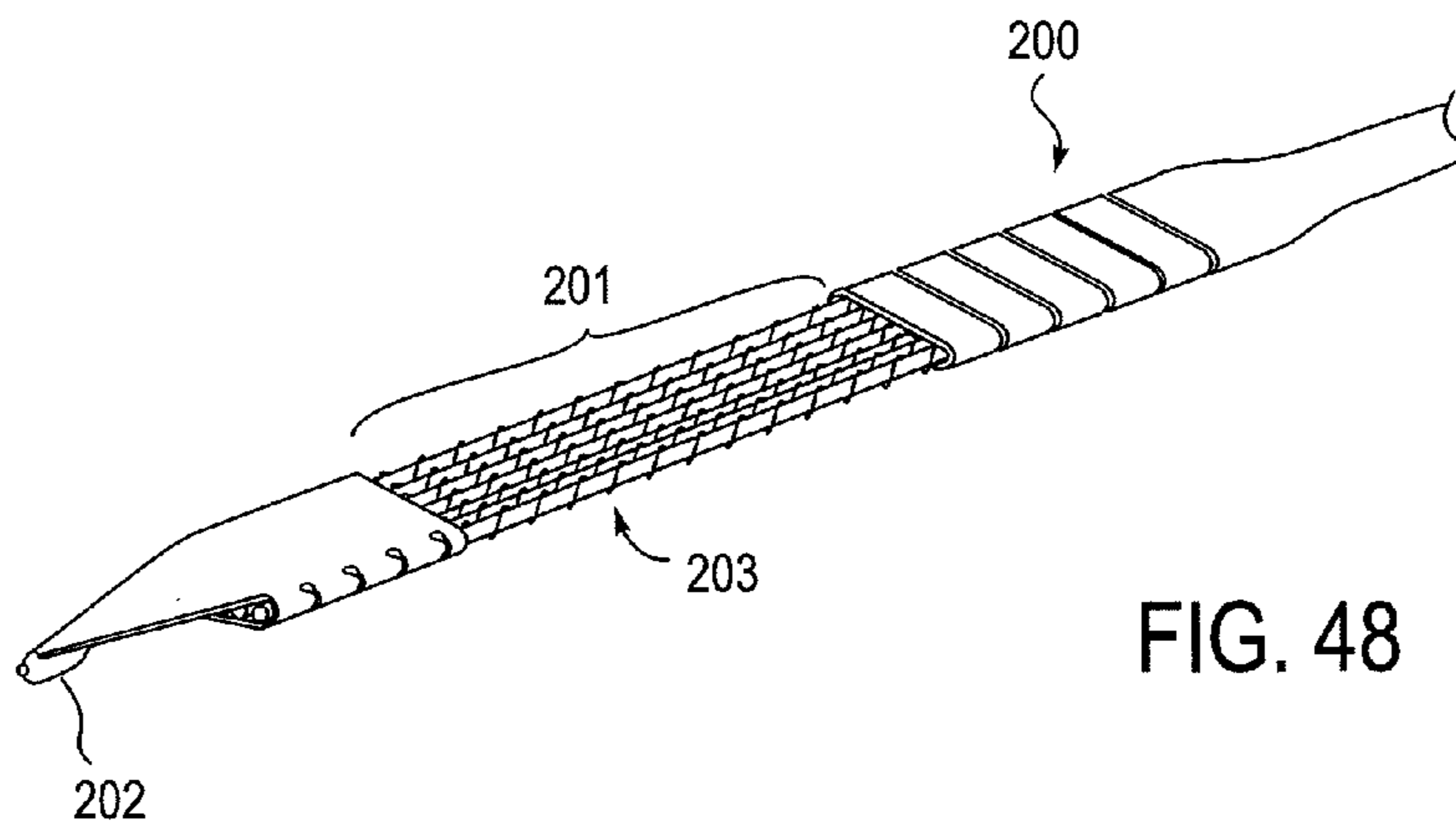

FIG. 48

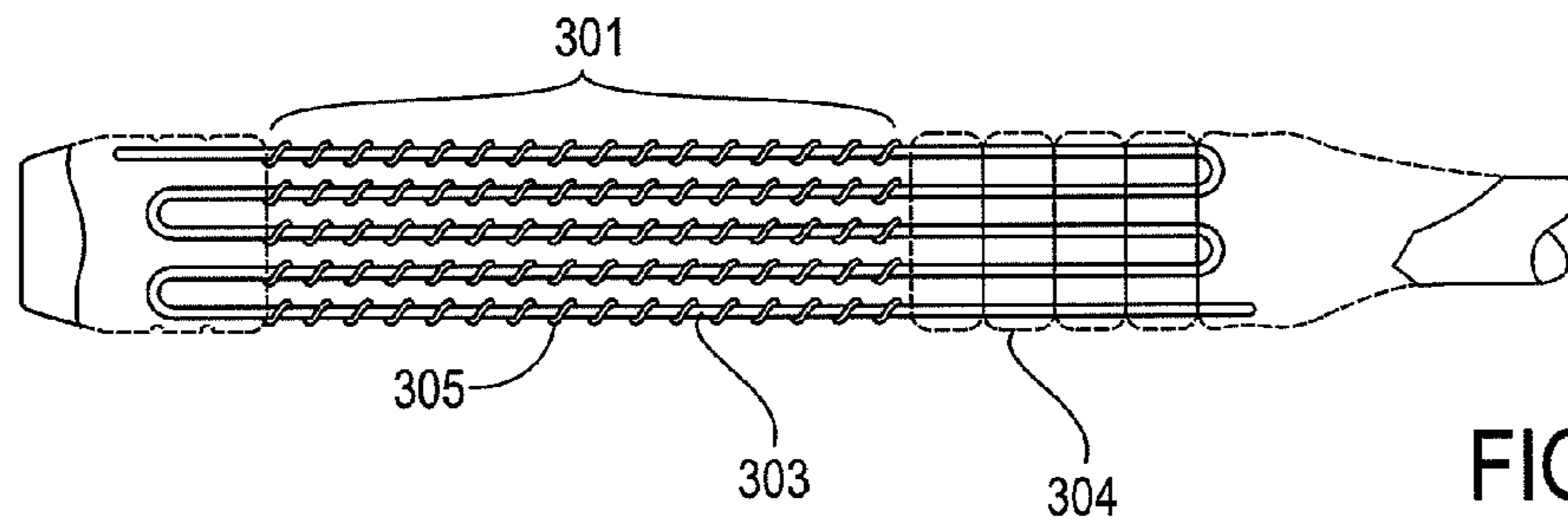

FIG. 49

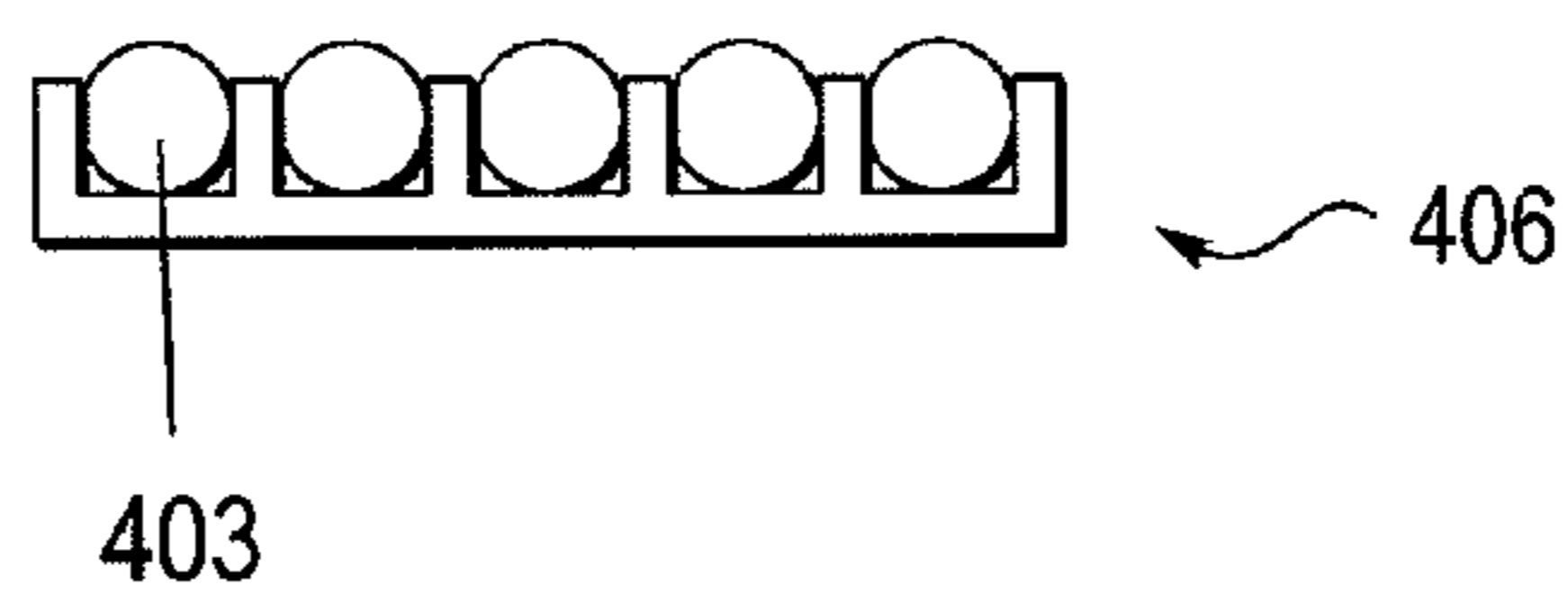

FIG. 50A

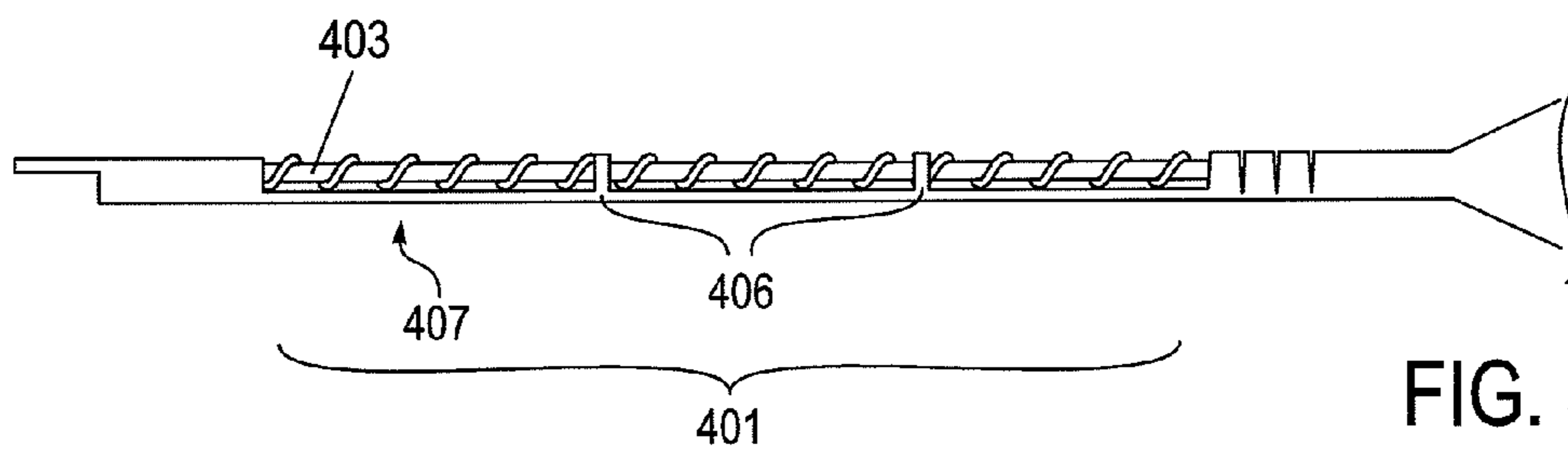

FIG. 50B

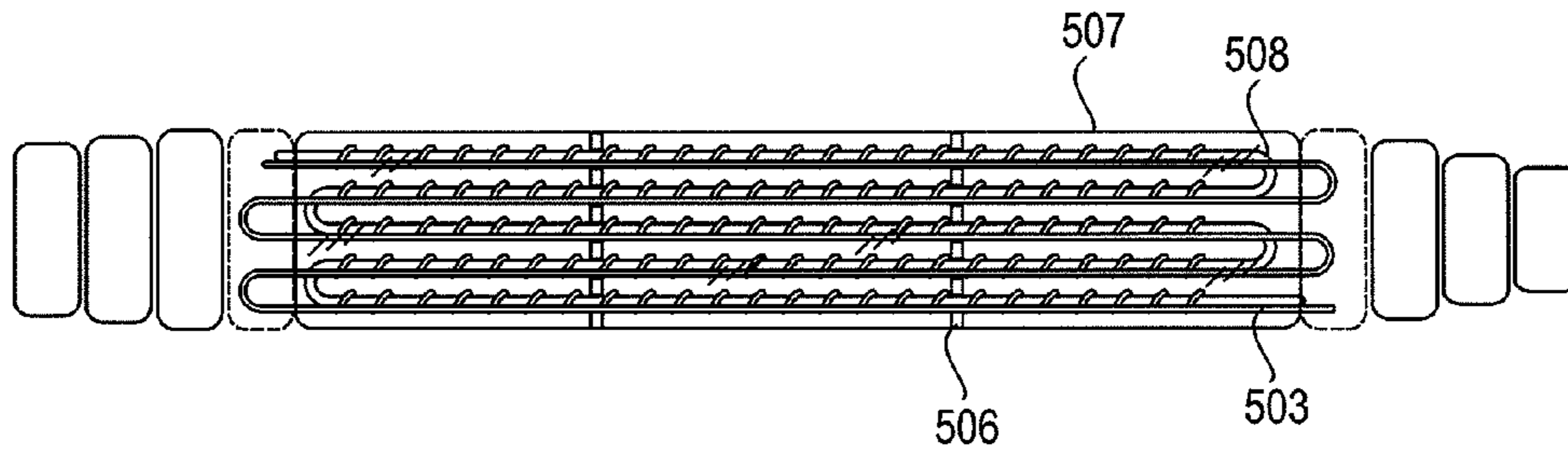

FIG. 51



FIG. 52A

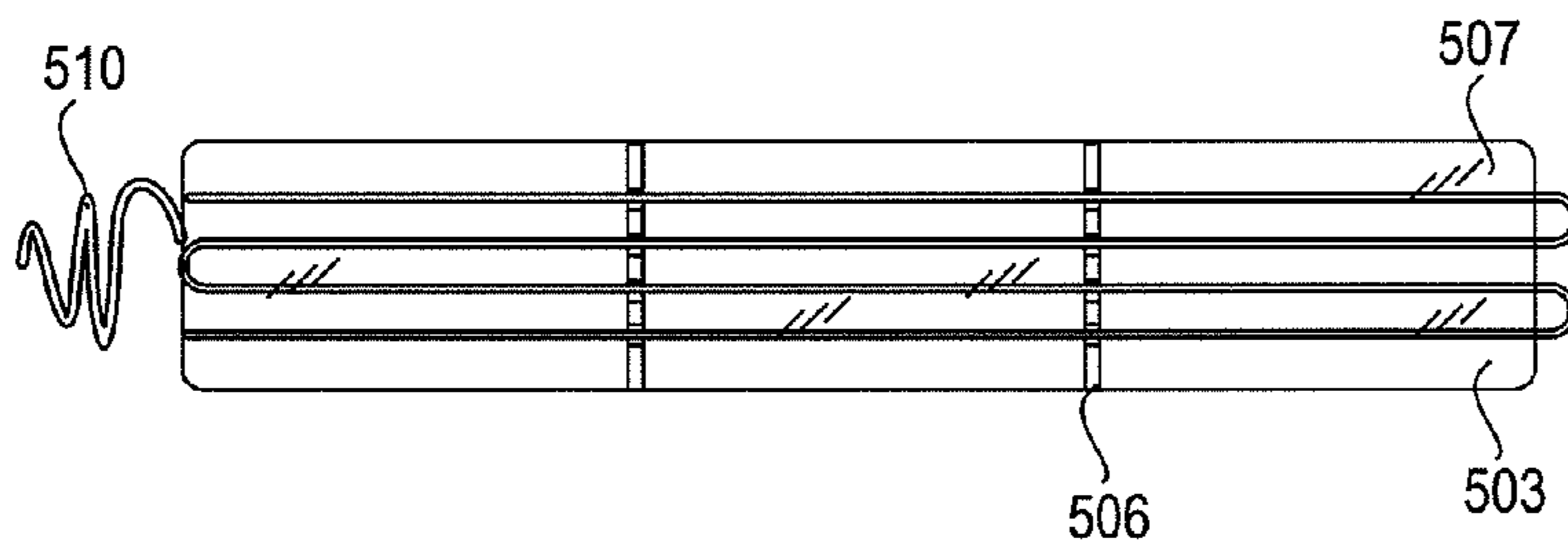

FIG. 52B

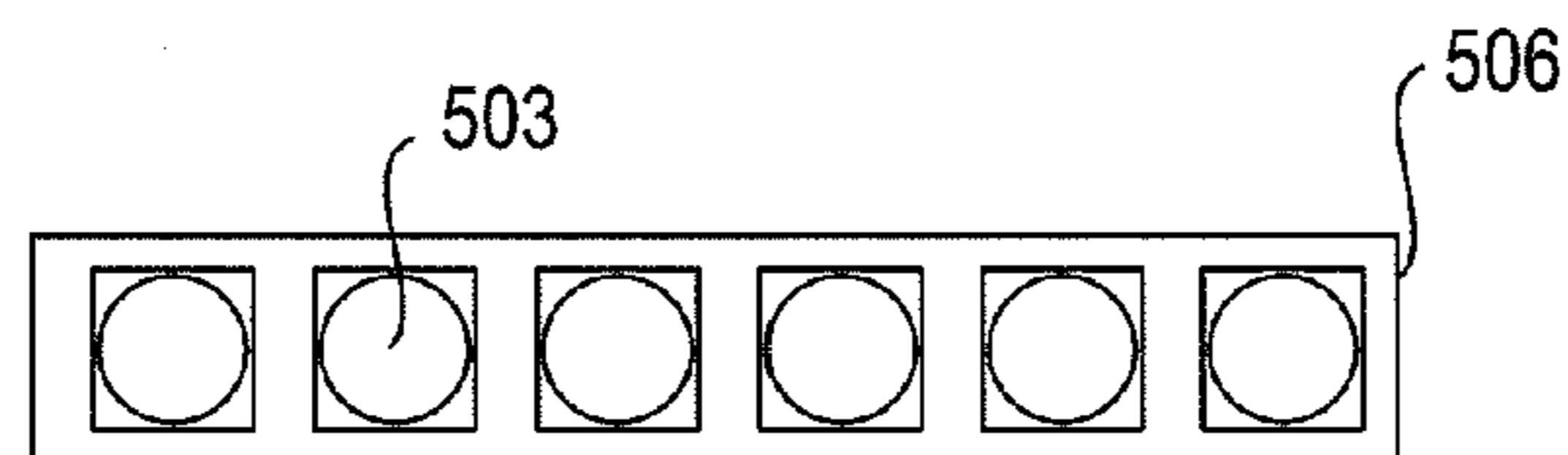

FIG. 52C



FIG. 53A

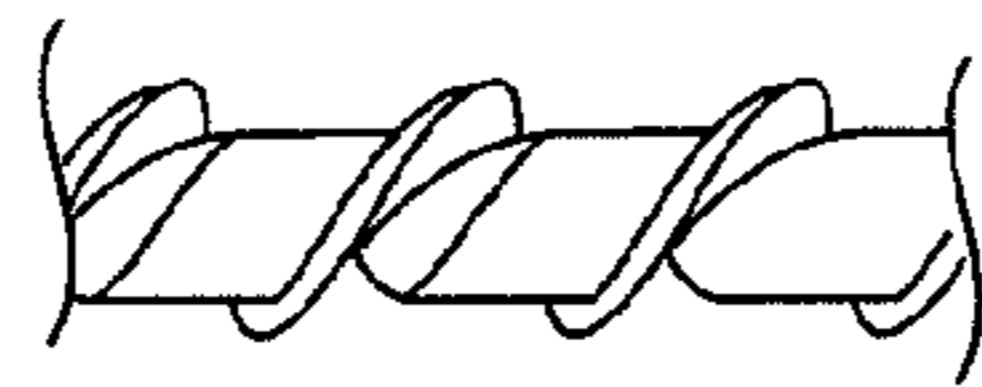

FIG. 53B

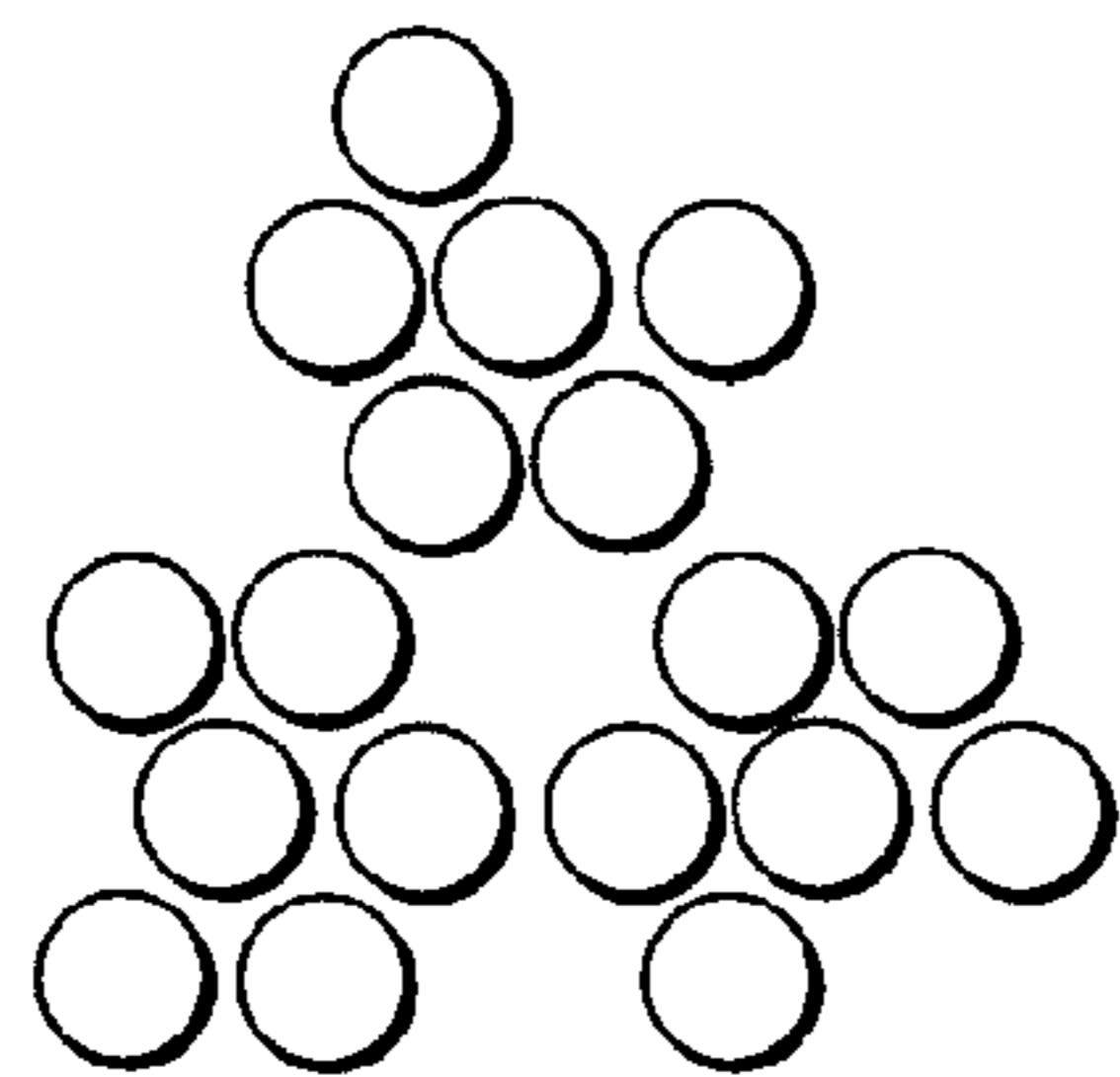

FIG. 53C

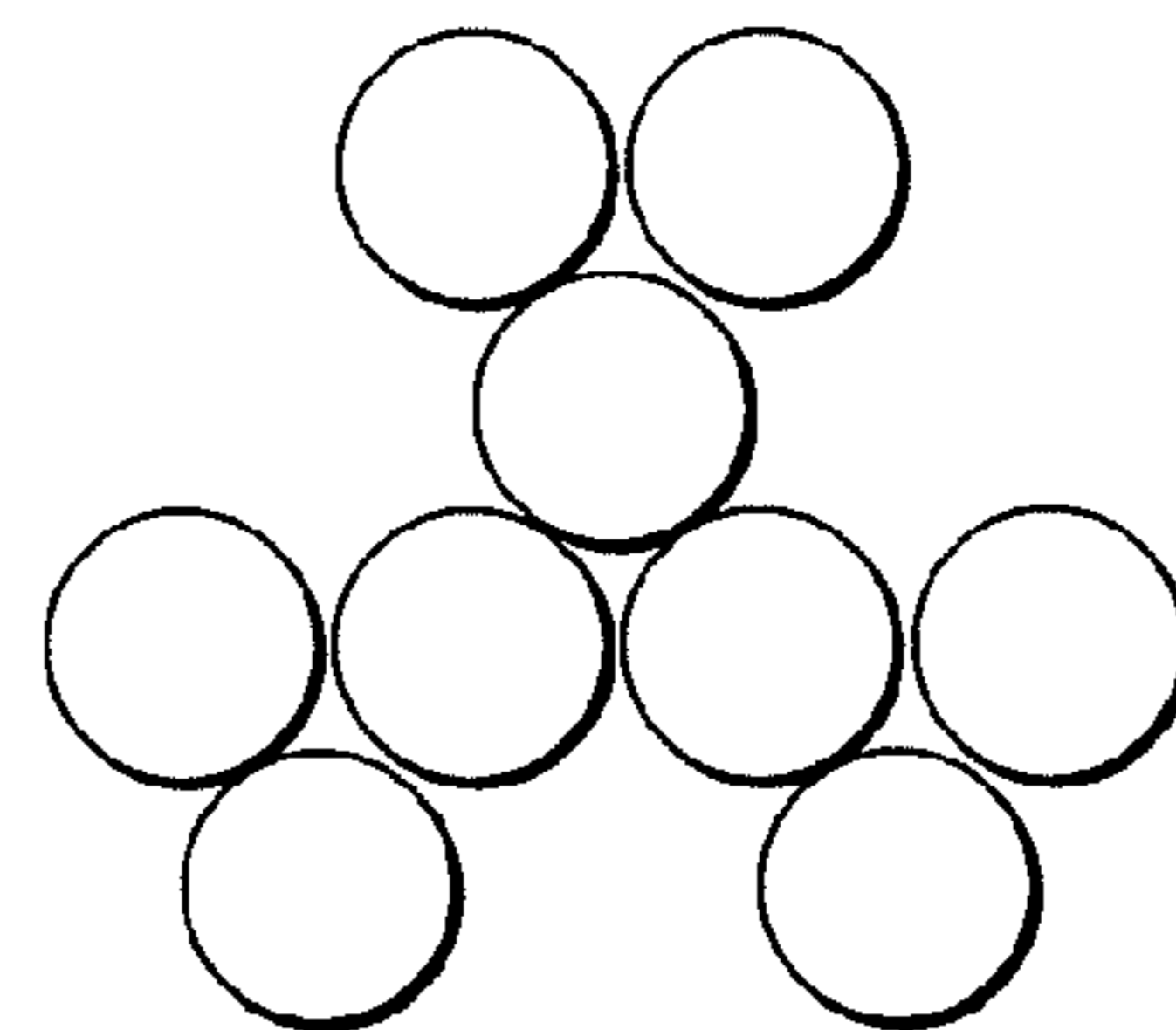

FIG. 53D

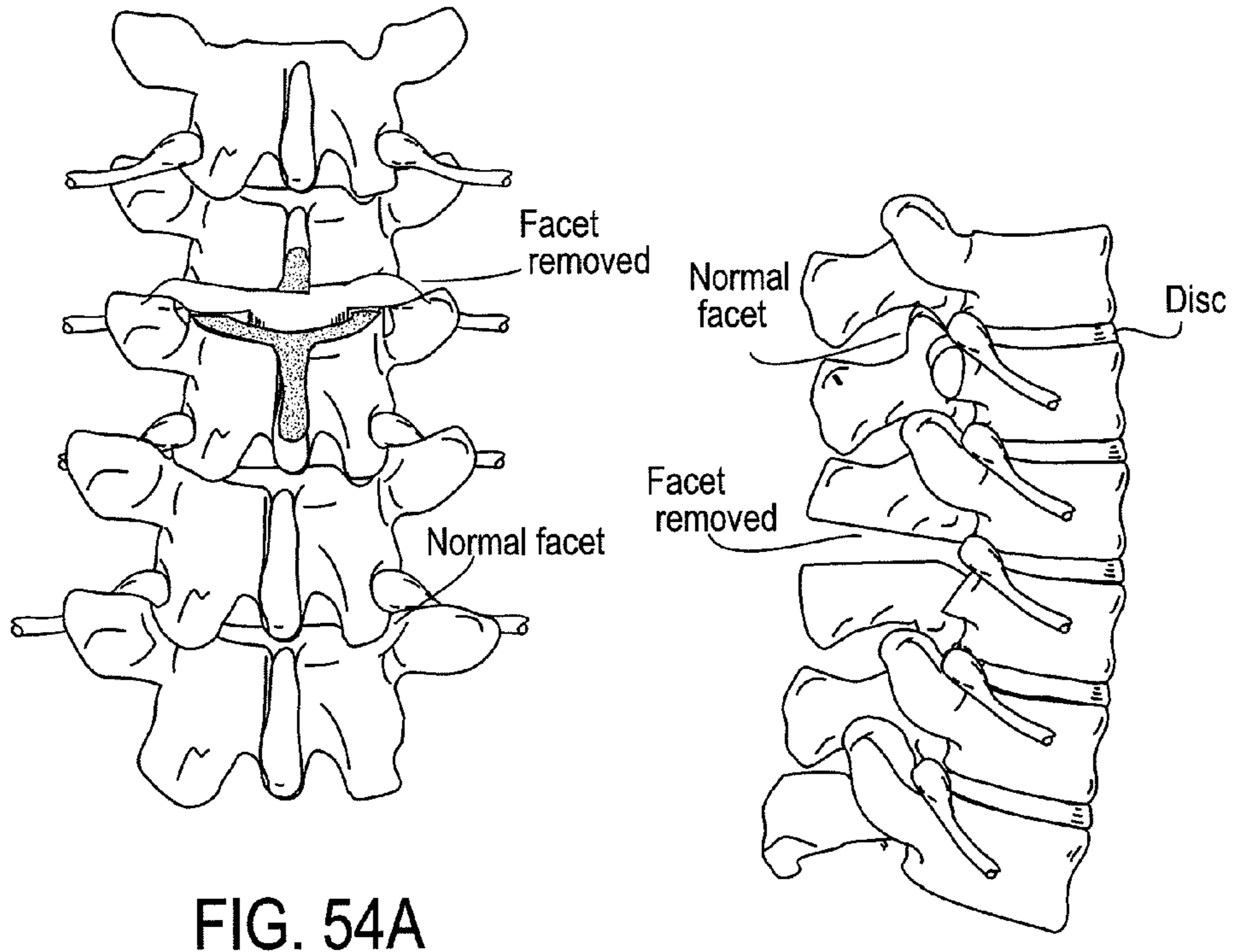

FIG. 54A

FIG. 54B

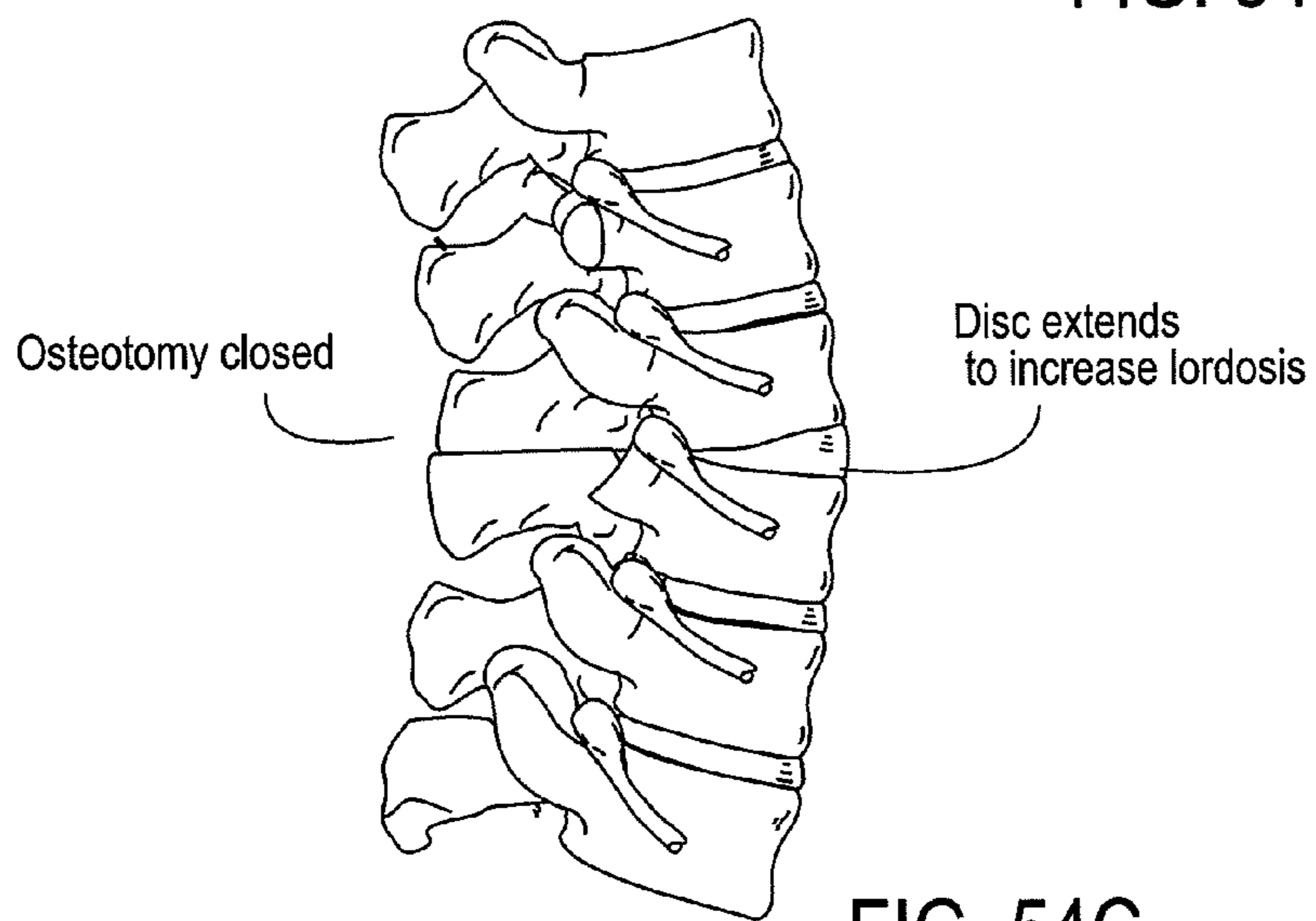

FIG. 54C

TISSUE MODIFICATION DEVICES AND METHODS

CROSS REFERENCE TO RELATED APPLICATIONS

This patent application is a continuation-in-part to U.S. patent application Ser. No. 12/773,595, titled "TISSUE MODIFICATION DEVICES AND METHODS", filed on May 4, 2010, Publication No. US-2010-0274250-A1, which claims priority to U.S. Provisional Application No. 61/175,323, titled "TISSUE MODIFICATION DEVICES", filed on May 4, 2009; U.S. Provisional Patent Application No. 61/254,638, titled "SPINAL BONE CUTTING DEVICES AND METHODS", filed on Oct. 23, 2009; and U.S. Provisional Patent Application No. 61/285,188, titled "SPINAL BONE CUTTING DEVICES AND METHODS", filed on Dec. 10, 2009.

U.S. patent application Ser. No. 12/773,595 is also a continuation-in-part to U.S. patent application Ser. No. 12/496,094, titled "ACCESS AND TISSUE MODIFICATION SYSTEMS AND METHODS", filed on Jul. 1, 2009, Publication No. US-2010-0004654-A1, now abandoned; which claims the benefit of U.S. Provisional Patent Application No. 61/077,441, titled "INNER SPINOUS DISTRACTION ACCESS AND DECOMPRESSION SYSTEMS", filed on Jul. 1, 2008.

U.S. patent application Ser. No. 12/773,595 is also a continuation-in-part to PCT Application No. PCT/US09/50492, titled "TISSUE MODIFICATION DEVICES", filed on Jul. 14, 2009, now Publication No. WO-2010-009093, which claims priority to U.S. Provisional Application No. 61/080,647, titled "TISSUE MODIFICATION DEVICES", filed on Jul. 14, 2008; U.S. Provisional Application No. 61/081,685, titled "TISSUE MODIFICATION DEVICES", filed on Jul. 17, 2008; and U.S. Provisional Patent Application No. 61/163,699, titled "TISSUE MODIFICATION DEVICES", filed on Mar. 26, 2009.

This patent application also claims priority to U.S. Provisional Patent Application No. 61/427,432, titled "TISSUE MODIFICATION DEVICES AND METHODS", filed on Dec. 27, 2010; and U.S. Provisional Patent Application No. 61/472,107, titled "TISSUE MODIFICATION DEVICES", filed on Apr. 5, 2011.

INCORPORATION BY REFERENCE

All publications and patent applications mentioned in this specification are herein incorporated by reference in their entirety to the same extent as if each individual publication or patent application was specifically and individually indicated to be incorporated by reference.

FIELD

Described herein are systems, devices, and methods of using them, for cutting spinal bone and soft tissue in a way that minimizes potential damage to surrounding tissue, and particularly the spinal nerves and vasculature. The methods, devices and systems described herein may be used as part of a spinal surgical procedure involving a complete or partial removal of spinal bone or joint, such as a laminectomy, laminotomy, fascetectomy, pediclectomy, etc.

BACKGROUND

Surgical intervention may require the manipulation of one or more medical devices in close proximity to a nerve or

nerves, which may risk damage to the nerve tissue. For example, medical devices may be used to cut, extract, suture, coagulate, or otherwise manipulate tissue including tissue near or adjacent to neural tissue. Spinal decompressions, are one type of procedure that may be preformed to remove tissue that is impinging on a spinal nerve. It would be beneficial to be able to cut or manipulate tissue (and especially bone) in a way that avoids or protects nearby structures such as nerves, while allowing precise removal of bone or portions of bones.

For example, a Transforaminal Lumbar Interbody Fusion ("TLIF") procedure is a surgical technique to stabilize the spinal vertebra and the disc or shock absorber between the vertebrae. In this procedure, lumbar fusion surgery creates a solid structure (bone and/or interbody device) between adjoining vertebrae, eliminating any movement between the bones. The goal of the surgery is to reduce pain and nerve irritation. The procedure typically involves removal of a great deal of spinal bone, e.g., by cutting through the patients back and removing the facet joints to create an opening into which a spacer or interbody cage can be inserted and filled with bone graft material. Interbody devices such as cages or spacers are typically 8 mm wide to 15 mm wide. Pedicle screws and rods or plates may then be used to fuse the vertebra.

It is common to do a laminectomy as part of the TLIF procedure, in order to provide space for the insertion of the spacer or cage. Other, similar procedures such as Posterior Lumbar Interbody Fusion (PLIF) procedures also involve cutting and removing a region of bone from the spine, such as the removal of a portion of the inferior articulating process (TAP). Removal of these relatively large portions of bone may be difficult, and may require cutting through a substantial amount of otherwise healthy tissue. In addition, the effort of cutting through the bone may damage nearby tissue, including nerve tissue such as nerve roots which are intimately associated with the spine in the dorsal column region being modified. The risks and difficulties of the procedures described above and other such surgical procedure may be exacerbated by the need to make multiple cuts in bone and other tissues, which are typically performed sequentially.

In addition, procedures such as these that involve cutting of spinal bone must be performed in difficult to reach regions, and the surgical procedures performed may necessarily need to navigate narrow and tortuous pathways. Thus, it would be of particular interest to provide devices that are extremely low profile, or are adapted for use with existing low-profile surgical devices and systems. It would also be beneficial to provide devices capable of making multiple, simultaneous cuts at different positions in the tissue (e.g., bone).

Described herein are devices, systems and methods that may address many of the problems and identified needs described above.

SUMMARY OF THE DISCLOSURE

Described herein are devices, systems and methods for cutting predetermined regions of a spine.

In general, the methods described herein include making two cuts through bone in the dorsal spinal column (e.g., through the pedicles, lamina, or other bony regions of the spinal column). The cuts may be made simultaneously (e.g., using a device having two cutting elements which may be arranged in parallel) or sequentially. The method typically begins with the delivery of a guidewire around the target bone region. The guidewire is passed into the body from a first location, around the target bone, and out of the body at a second location. The guidewire may be positioned using one or more needles, cannula, etc. that can steer the guidewire as

it is inserted. This method is described in many of the patents incorporated by reference above. The distal end of the guidewire may be sharp, so that it can penetrate the tissue as the guidewire is pushed from the proximal end. The proximal end of the guidewire may be adapted to link securely (and removably) to the distal end of a cutting device, such as a cutting wire saw.

After passing the guidewire around the target bone to be cut, an electrode or other neural localization device (as described in some of the reference incorporated in their entirety above) may be used to confirm that a nerve (e.g., spinal nerve) is not located between the guidewire and the bone to be cut, which could damage the nerve. For example, the distal end of a ribbon-shaped neural localization device (having a relatively flat and flexible profile) may be coupled via a guidewire coupling member to the distal end of the guidewire and pulled into position around the bone, then stimulated by applying electrical current to electrodes on the surface(s) of the neural localization device to confirm that a nerve is not present. If a nerve is present between the target bone and the neural localization device, the guidewire may be removed and repositioned, then the detection process repeated. Other neural localization methods or devices may be used, including visual detection/confirmation of nerve location, detection by electrical impedance measurements, ultrasound, or the like.

Once the guidewire is positioned in the desired pathway to be taken by the cutting element for cutting the bone, a protective element (e.g., cover, shield, etc.) may be positioned by pulling it into position using the guidewire. In some variations the neural localization device is configured as a shield or cover. For example, a shield or cover may be a flat, thin and flexible elongate (e.g., ribbon-shaped) body that can be positioned using the guidewire. The protective element may include a channel or path for the guidewire. In some variations the protective element may be pulled (e.g., pulled distally) into position using the guidewire after coupling the distal end of the protective element to the guidewire, and then the guidewire may be pushed proximally so that the proximal end of the guidewire extends back out of the patient and can be coupled to a second element (e.g., cutting element) while the distal end of the protective device remains in position. In some variations a second guidewire may be passed along the same or a parallel pathway through the tissue to position additional elements such as a cutting element. Channels in/on the protective element may assist with this. Alternatively, in some variations the protective element may be positioned over the guidewire, without coupling to the distal end.

Once the pathway around the target bone to be cut has been determined (and in some variations protected), a cutting tool such a wire saw may then be positioned by coupling the cutting tool to the end of the guidewire and pulling the guidewire to pull the cutting tool (e.g., wire saw) into place. The cutting tool is optimally a thin, flexible cutting tool that may be used bimanually, e.g., by pulling on both the proximal and distal ends of the device to cut the bone. Examples of cutting devices include reciprocating cutting devices, and some examples of these are described below. Cutting elements may be abrasive (e.g., having an abrasive surface). A cutting element may be a wire saw, such as a Gigli saw, as known in the art, which is adapted for use as described herein. Cutting elements are not limited to mechanical cutters. Other cutting elements may include electrical cutting elements, thermal (heat) cutting devices, or the like.

In some variations a separate guidewire is not used, but the cutting element acts as a guidewire. For example, the cutting

element may include an integrated guidewire to the distal end. In some variations, the guidewire may be adapted as a cutting element.

Once positioned around the target tissue, the ends of the cutting element may be grasped manually or grasped using an assist device, and the cutting element may be activated (e.g., by manual reciprocation) to cut the bone. Cutting the bone typically means cutting completely through the bone. In variations in which the cutting element is coupled to a guidewire, the cutting element may be reciprocated by pulling on the distal end of the guidewire.

Manual reciprocation of the guidewire may be performed from outside of the patient. The direction of pulling and/or reciprocation may be based on the direction of cutting intended. For example, when it is desirable to cut the bone (e.g., the superior articulating process or SAP) laterally so that the cut extends in the lateral direction relative to the spine, the proximal and distal ends of the cutting element extending from the patient (or the portions of a guidewire or other wire connected to the cutting element that extends from the patient and can be grasped to manipulate the device) are pulled so that the force vector applied by pulling on the two ends at an angle points in the generally lateral direction. In general, the direction of cutting using a flexible wire system as described herein will be determined by the force vector resulting as the ends of the flexible cutting element is pulled from both ends. The pulling force may be alternated—e.g., to reciprocate the cutting element against the tissue.

In some variations, an assist or guide element may be used to help position the cutting element as it is reciprocated against the spine. For example, an assist device or guide may push the cutting element against the tissue, helping to control the direction of the cutting.

The methods described herein may include a device configured to allow simultaneous cutting of two or more bone regions. For example, a device for cutting bone may include two parallel cutting elements that are separated by a predetermined spacer or spaces. The distal and proximal end regions of the cutting elements are connected so that reciprocating the ends of the device will cause reciprocation of both cutting elements. As mentioned, the cutting elements are typically flexible, and may be connected so that they remain separated by a predetermine spacing even when contacting bone or during positioning. For example, the two parallel cutting elements may be separated by a distance of between about 4 and 16 mm, or between about 6-14 mm, or between about 8-15 mm. The two (or in some variations, more than two cutting elements are typically arranged along the long axis (length) of the device. In some variations, the cutting elements may be approximately parallel or actually parallel. In some variation, the cutting elements are not parallel, for example, the cutting surfaces may be slightly angled relative to each other, and the device may be configured so that the distance between the cutting edges may be varied or altered.

In variations in which two or more cuts to remove a portion of bone are made sequentially (rather than in parallel), the method may include cutting the first portion of the bone, then moving the cutting element to the start of the second cut without removing the cutting element from the tissue. Thus, both sides of a cut to remove the bone may be made without removing the cutting element. Cutting a section of bone completely away without having to remove the flexible cutting element (e.g., wire) from the body is one advantage of the methods described herein.

When two cuts are made sequentially as mentioned above, an additional positioning device may be used to push, pull or otherwise guide the middle of the cutting element (e.g., the

5

region looped around the bone) into position around the bone at the desired second cutting position. For example, a wire saw may be used to cut the SAP laterally, then, after cutting completely through the SAP, the bent portion of the cutting element in the tissue may be moved into position by pushing it or sliding it to the second location. An example of this is provided below. The positioning device may be a rigid or stiff member having a distal end configured to push or grasp the loop of the cutting element. Since the bone being cut will be removed, in some variations the procedure includes the step of cutting through the tissue to expose the bone. One or more probes may be inserted into this cut and used to position the wire either using a manipulating device once it has been looped around the tissue as desired, or to position the probes to pass the guidewire around the bone to be cut.

Although an opening into the bone may be formed to remove the bone region cut away, it may be beneficial to pass the guidewire around the target bone from a separate (even minimally invasive) access point. Thus, the cut into the tissue to remove the bone may be kept relatively small (e.g., sufficiently large enough only to retrieve the bone that is cut away), while separate pathways for the wire saw may be formed through the tissue in the directions that the wire saw will be reciprocated. In other variations the procedure may be preformed substantially "open," exposing a region of the bone, and allowing manipulation of the ends of the guidewire and/or cutting element as necessary to cut at the desired angles and remove the bone.

In some variations, the methods described herein are adapted for cutting a region of a spinal facet (e.g., cutting on one side of a superior articulating process) specifically, to permit insertion of a device such as a cage or spacer. Described below is a specific example of one procedure and variations of devices that may be used to perform the procedure, as well as systems including such devices. In some variations, the method and devices described herein are adapted for cutting bone to perform an osteotomy. For example, in scoliosis reduction surgery portions of bone are removed to aid in the straightening of the spine. In some variations, the methods and devices described herein are adapted for cutting a spinous process or transverse process or any other suitable portion of bone.

Also described herein are improved devices for modifying tissue and methods of using them. These devices may be included as part of a system for modifying tissue. The tissue modification devices described herein typically include an elongate, flexible length and a tissue modification element coupled to the flexible element. The flexible element may include an expanding mechanism that expands at least a portion of a flexible element from a first width to a second width. A tissue modification device may include one or more of these features in any combination.

Methods for modifying tissue as described herein may include one or more of the following steps: inserting an elongate, flexible element having a first width; advancing the flexible element until a portion of the flexible element is adjacent to a target tissue; expanding at least the portion the flexible element adjacent to the target tissue to a second width; and modifying the target tissue with the flexible element.

The methods for modifying tissue described may alternatively include one or more of the following steps: inserting a first elongate, flexible element into the patient at a first location; advancing the first flexible element until a portion of the flexible element is adjacent to a target tissue; inserting a second elongate, flexible element into the patient at the first

6

location, a distance from the first flexible element; and modifying the target tissue with the flexible elements.

Any of the devices described herein may be used as part of a tissue decompression (e.g., spinal decompression) method to modify tissue such as soft tissue (e.g., ligamentum flavum, etc.) and hard tissue (e.g., bone). In particular, these devices may be used as part of a spinal decompression technique within a spinal foramen.

The devices described herein may be used as part of a guide-based access and decompression system, including those previously described in any of the following patent applications and provisional patent applications, each of which is herein incorporated by reference in its entirety: U.S. patent application Ser. No. 11/250,332, titled "DEVICES AND METHODS FOR SELECTIVE SURGICAL REMOVAL OF TISSUE", filed on Oct. 15, 2005, now U.S. Pat. No. 7,738,968; U.S. patent application Ser. No. 11/251,199, titled "DEVICES AND METHODS FOR TISSUE ACCESS", filed on Oct. 15, 2005, Publication No. US-2006-0095059-A1; U.S. patent application Ser. No. 11/375,265, titled "METHODS AND APPARATUS FOR TISSUE MODIFICATION", filed on Mar. 13, 2006, now U.S. Pat. No. 7,887,538; U.S. patent application Ser. No. 11/405,848, titled "MECHANICAL TISSUE MODIFICATION DEVICES AND METHODS", filed on Apr. 17, 2006, Publication No. US-2007-0213733-A1; U.S. patent application Ser. No. 11/429,377, titled "FLEXIBLE TISSUE RASP", filed on May 4, 2006, now U.S. Pat. No. 8,048,080; U.S. patent application Ser. No. 11/538,345, titled "ARTICULATING TISSUE CUTTING DEVICE", filed on Oct. 3, 2006, Publication No. US-2008-0161809-A1; U.S. patent application Ser. No. 11/687,548, titled "TISSUE REMOVAL WITH AT LEAST PARTIALLY FLEXIBLE DEVICES", filed on Mar. 16, 2007, now U.S. Pat. No. 8,062,300; U.S. patent application Ser. No. 11/687,558, titled "FLEXIBLE TISSUE REMOVAL DEVICES AND METHODS", filed on Mar. 16, 2007, now U.S. Pat. No. 8,062,298; U.S. patent application Ser. No. 11/870,370, titled "PERCUTANEOUS SPINAL STENOSIS TREATMENT", filed on Oct. 10, 2007, Publication No. US-2008-0103504-A1; and U.S. patent application Ser. No. 12/127,535, titled "GUIDEWIRE EXCHANGE SYSTEMS TO TREAT SPINAL STENOSIS", filed on May 27, 2008, Publication No. US-2008-0275458-A1.

In particular, the devices described herein may be used as a guidewire-based system that is configured so that the device may be pulled into position and/or tensioned so as to be urged against a tissue, and thereby modify the tissue. This configuration may be referred to as a bimanual system, since both ends (e.g., the proximal end and the distal end of the device) may be tensioned or pulled to modify the tissue. Tissue may be modified by removal or smoothing of the tissue, and may be performed by pulling the devices described herein through the tissue so that the working surface (e.g., the blades on the rungs) contacts one or more tissue surfaces.

Also described herein are delivery devices for delivering tissue modification devices for removing tissue from a patient. In some embodiments, the device includes a ribbon shaped flexible elongate body having a width defined by a first edge and a second edge. In some embodiments, the first and second edges are substantially parallel. The device may also include a first channel, configured to receive a first elongate cutting member, disposed along a portion of the length of the elongate body, positioned toward the first edge of the elongate body, and a second channel, configured to receive a second elongate cutting member, disposed along a portion of the length of the elongate body, positioned toward the second

edge of the elongate body. In some embodiments, the device may also include a guidewire coupler at the distal end region of the elongate body.

In some embodiments, a first flexible elongate cutting member is disposed within the first channel and/or a second flexible elongate cutting member is disposed within the second channel.

Also described herein are methods for delivering tissue modification devices for removing tissue from a patient. In some embodiments, the methods include the steps of inserting an elongate, flexible shield into the patient at a first location; advancing the shield until a portion of the shield is adjacent to a target tissue; inserting a first elongate, flexible cutting element through the shield until a portion of the first cutting element is adjacent to a target tissue; inserting a second elongate, flexible cutting element through the shield, a distance from the first cutting element and substantially parallel to the first cutting element, until a portion of the second cutting element is adjacent to a target tissue; and modifying the tissue with the flexible elements.

In some embodiments, the methods include the steps of inserting a first elongate, flexible cutting element until a portion of the first cutting element is adjacent to a target tissue; advancing an elongate, flexible shield into the patient, wherein a portion of the shield is advanced over the first elongate, flexible cutting element; inserting a second elongate, flexible cutting element through the shield, a distance from the first cutting element and substantially parallel to the first cutting element, until a portion of the second cutting element is adjacent to a target tissue; and modifying the tissue with the flexible elements. In some embodiments, the methods further include the step of removing the shield from the patient while leaving the cutting elements in position within the patient.

In some embodiments, a bimanually controlled tissue modification device having a tissue modification region for cutting tissue in a patient includes a pair of flexible elongate cutting members extending along the length of the tissue modification region. Each elongate cutting member may have a thickness and each elongate cutting member may be configured to cut a discrete trough into tissue to a depth that is greater than the thickness of the cutting member. In some embodiments, the device includes a guidewire coupler distal to the tissue modification region of the device. The guidewire coupler may be configured to be coupled to a guidewire, e.g., at the proximal end of the guidewire, and the tissue modification region may be actuated by pulling on a proximal handle on or connected to the device, and on a guidewire coupled to the distal end of the device. In some embodiments, the tissue modification region is configured to be actuated by a proximal handle and a distal handle. In some embodiments, the guidewire coupler is configured such that the device is removably attachable to a proximal end region of a guidewire such that the tissue modification region can be pulled into position by pulling on the guidewire while the proximal end region of the guidewire is held stationary by the guidewire coupler with respect to the device. Alternatively, in some embodiments, the device includes a flexible guide at the distal end of the tissue modification device, wherein the guide is configured such that the tissue modification region can be pulled into position by pulling on the guide.

In some embodiments, at least one cutting member comprises a cutting wire, while in some embodiments, at least one cutting member comprises a Gigli wire or an elongate wire having a helical cutting edge along the length of the wire. In

some embodiments, at least one cutting member comprises an elongate cable having blade edges distributed along the length of the cable.

In some embodiments, the device includes a spacer coupled to the elongate cutting members of the tissue modification region, wherein the spacer is sized and configured to temporarily hold the cutting members a distance from one another. In some embodiments, the spacer comprises an elongate, flexible, ribbon-shaped substrate and in some embodiments, the spacer includes a restraint (e.g., "coupler") toward the outer edge region of the spacer and configured to temporarily secure a cutting member to the outer edge region of the spacer. In some embodiments, the spacer is sized and configured to slide along the length of the elongate cutting members. The restraint may be referred to herein as a coupler as it may engage with and restrain the cutting elements or another element coupled to the cutting elements (e.g., cable, etc.) to maintain a lateral separation between the cutting elements as described herein.

In some embodiments, the device further includes a plurality of flexibly connected rungs, wherein each rung extends at least partially across the width of the device. In some embodiments, the rungs are proximal and distal to the tissue modification region of the device. In some embodiments, the device further includes a connector linking adjacent rungs. In some embodiments, the connector may include at least one cable, and in some embodiments, the cable may form the first elongate cutting member and the second elongate cutting member.

In general, a bimanually controlled tissue modification device for cutting tissue in a patient may include a pair of flexible, elongate cutting members extending along the elongate length of the device, and a spacer that may be positioned between the cutting members. In some embodiments, the spacer is sized and configured to operate in one of two modes: a first mode, wherein the spacer is coupled to the cutting members such that it holds a portion of each of the two cutting members a distance from one another across the width of the device; and a second mode, wherein at least a portion of the spacer is moved away from a cutting member to allow the cutting members to cut further into tissue. In the first mode, the spacer(s) may be in the same plane as the cutting member, while in the second mode the spacer(s) may be displaced out of the plane.

In some embodiments, the elongate cutting members are substantially parallel to one another. In some embodiments, the spacer in the second mode is positioned out of the plane of the cutting members. The device may include a guidewire coupler at the distal end region of the tissue modification device. In some embodiments, the spacer in the second mode is positioned such that each of the cutting members can cut a depth into tissue that is greater than the thickness of the cutting members. In some embodiments, the spacer further comprises a coupler configured to couple the spacer to a cutting member while the spacer is in the first mode. In some embodiments, the spacer transitions from the first mode to the second mode as the cutting member cuts through the coupler. In some embodiments, the spacer transitions from the first mode to the second mode as the coupler slides along the length of the elongate cutting member. Any appropriate number of spacers may be used. The same device may use different types or configurations of spacers.

In some embodiments, the coupler may be a deformable material sized and configured such that the spacer transitions from the first mode to the second mode as the deformable material deforms and a portion of the spacer moves with respect to the cutting member. In some embodiments, the

device further includes a spring, wherein the spring is configured to expand as the spacer transitions from the first mode to the second mode. In some embodiments, the cutting members are sized and configured to cut a first depth into the tissue while the spacer is in the first mode and to cut a second, greater depth into the tissue while the spacer is in the second mode. In some embodiments, the cutting members are configured to be actuated by a proximal handle and a distal handle. The cutting members may be reciprocated, for example, they may be pulled distally by a distal handle and pulled proximally by a proximal handle.

In general, a method of modifying tissue may include the steps of passing an elongate, flexible tissue-modification device at least partially around a target tissue; moving a tissue-modification region of the device against the target tissue by pulling the tissue-modification device from at least one end of the device; and cutting two discrete elongate troughs into the tissue with a pair of flexible elongate cutting members extending along the elongate length of the tissue modification region. For example, the elongate cutting members may have a thickness (e.g., between about 0.01 cm and about 5 cm) and each of the elongate troughs may be cut to a depth that is greater than the thickness of the cutting members. In some embodiments, the elongate troughs each have a depth greater than 1 cm. In some embodiments, the elongate troughs each have a depth greater than 2 cm. In some embodiments, the elongate troughs are substantially parallel to one another.

As mentioned, the troughs are typically discrete, and separated from each other. In some variations, the troughs may join or meet as the device continues to cut into the tissue (e.g., bone). The spacing between the troughs may be predetermined (e.g., 4 mm, 5 mm, 6 mm, 7 mm, 8 mm, 9 mm, 10 mm, 11 mm, 12 mm, 13 mm, 14 mm, 15 mm, 16 mm, 17 mm, 18 mm, etc.), which may correspond to the spacing between cutting elements on the cutting device.

In some embodiments, the method further includes the step of removing the target tissue. The target tissue may comprise at least a portion of a facet joint. In some embodiments, the step of passing the tissue-modification device at least partially around the target tissue comprises passing a guidewire at least partially around the target tissue and pulling the flexible tissue-modification device around the target tissue using the guidewire. In some embodiments, the cutting step includes the steps of cutting the troughs to a first depth into the tissue with a pair of flexible elongate cutting members held a distance from one another with a spacer and cutting the troughs to a second, greater depth into the tissue with the pair of flexible elongate cutting members.

The spacer may be moved with respect to the cutting members before cutting the troughs to the second, greater depth. In some embodiments, the method includes the step of collecting cut tissue with the spacer as the spacer moves away from the cutting members. The step of moving the tissue-modification device against tissue may comprise applying tension to both the proximal end and the distal end of the tissue-modification device to drive the tissue-modification device against the tissue either simultaneously or sequentially (e.g., reciprocating it).

In some embodiments, the method includes the step of cutting through a coupler with at least one of the cutting members while cutting the troughs, wherein the coupler couples a spacer to the cutting member. In some embodiments, the method includes the step of detaching at least one of the cutting members from a coupler while cutting the troughs into the tissue, wherein the coupler couples a spacer to the cutting member. In some embodiments, the cutting step

further comprises reciprocating the tissue-modification region of the device against the target tissue by pulling the tissue modification region distally with a distal handle and by pulling the tissue modification region proximally with a proximal handle.

Described herein are bimanually controlled tissue modification devices for cutting tissue in a patient. In some embodiments, the device may include a tissue modification region; at least two flexible elongate lengths of cable, wherein the lengths of cable extend substantially adjacent to each other proximally to distally; a plurality of rungs extending between the lengths of cable, wherein the rungs are proximal and distal to the tissue modification region of the device; a pair of flexible elongate cutting members extending along the length of the tissue modification region of the device, wherein each elongate cutting member has a thickness and the device is configured so that each elongate cutting member cuts a discrete trough into tissue to a depth that is greater than the thickness of the cutting member; an elongate, flexible, ribbon-shaped substrate sized and configured to releasably hold the cutting members a distance from one another; a pair of couplers positioned toward an outer edge region of the substrate and configured to releasably secure a cutting member to the outer edge region of the substrate; and a guidewire coupler at the distal end of the device configured to engage a tip of a guidewire.

In some embodiments, the flexible elongate lengths of cable link adjacent rungs. In some embodiments, the pair of flexible elongate cutting members and the flexible elongate lengths of cable are integrally formed. In some embodiments, each flexible elongate cutting member is coupled to a flexible elongate length of cable. In some embodiments, the distal ends of the flexible elongate lengths of cable are secured together. In some embodiments, the proximal ends of the flexible elongate lengths of cable are secured together. In some embodiments, the elongate cutting members are substantially parallel to one another. In some embodiments, the guidewire coupler is configured to be coupled to a guidewire, and wherein the tissue modification region is configured to be actuated by a proximal handle and a distal handle. In some embodiments, the guidewire coupler is configured such that the device is removably attachable to a proximal end region of a guidewire such that the tissue modification region can be pulled into position by pulling on the guidewire while the proximal end region of the guidewire is held stationary by the guidewire coupler with respect to the device. In some embodiments, at least one cutting member comprises an elongate wire having a helical cutting edge along the length of the wire.

In some embodiments, a bimanually controlled tissue modification device for cutting tissue in a patient may include a tissue modification region; a pair of flexible elongate cutting members extending along the length of the tissue modification region of the device, wherein each elongate cutting member has a thickness and the device is configured so that the cutting members cut a discrete trough into tissue to a depth that is greater than the thickness of the cutting member; an elongate, flexible, ribbon-shaped substrate removably coupled to the elongate cutting members of the tissue modification region, wherein the substrate is sized and configured to releasably hold the cutting members a distance from one another; and a guidewire coupler at the distal end of the device configured to engage a tip of a guidewire.

In some embodiments, the substrate further comprises a coupler toward the outer edge region of the substrate and configured to temporarily secure a cutting member to the outer edge region of the substrate. In some embodiments, the substrate is sized and configured to slide along the length of

the elongate cutting members. In some embodiments, the elongate cutting members are substantially parallel to one another.

In some embodiments, a bimanually controlled tissue modification device for cutting tissue in a patient may include a tissue modification region; a pair of flexible elongate cutting members extending along the length of the tissue modification region of the device, wherein each elongate cutting member has a thickness and the device is configured so that the cutting members cut a discrete trough into tissue to a depth that is greater than the thickness of the cutting member; an elongate, flexible, ribbon-shaped substrate sized and configured to releasably hold the cutting members a distance from one another; and a pair of couplers, wherein each coupler is positioned toward an outer edge region of the substrate and each coupler is configured to releasably secure a cutting member to the outer edge region of the substrate.

In some embodiments, the elongate cutting members are substantially parallel to one another. In some embodiments, the substrate is further configured to decouple from the cutting members such that the cutting members can cut a discrete trough into tissue to a depth that is greater than the thickness of the cutting member. In some embodiments, the substrate is decoupled from the cutting members it is positioned out of the plane of the cutting members. In some embodiments, the substrate decouples from the cutting members as the cutting members cut through the couplers. In some embodiments, the substrate decouples from the cutting members as the couplers slide along the length of the elongate cutting member. In some embodiments, the couplers comprise a deformable material sized and configured such that the substrate decouples from the cutting members as the deformable material deforms and a portion of the substrate moves with respect to the cutting members.

In some embodiments, the device may further include a spring, wherein the spring is configured to expand as the substrate decouples from the cutting members. In some embodiments, the cutting members are sized and configured to cut a first depth into the tissue while the substrate is coupled to the cutting members and to cut a second, greater depth into the tissue when the substrate decouples from the cutting members. In some embodiments, the cutting members are configured to be actuated by a proximal handle and a distal handle. In some embodiments, wherein the cutting members are configured to be reciprocated, wherein they are configured to be pulled distally by a distal handle and are configured to be pulled proximally by a proximal handle.

In some embodiments, a bimanually controlled tissue modification device for cutting tissue in a patient may include a tissue modification region; at least two flexible elongate lengths of cable, wherein the lengths of cable extend substantially adjacent to each other proximally to distally; a plurality of rungs extending between the lengths of cable, wherein the rungs are located proximal and distal to the tissue modification region of the device; a pair of flexible elongate cutting members extending along the length of the tissue modification region of the device, wherein each elongate cutting member has a thickness and the device is configured so that the cutting members cut a discrete trough into tissue to a depth that is greater than the thickness of the cutting member; and a guidewire coupler at the distal end of the device configured to engage a tip of a guidewire.

In some embodiments, the device may further include an elongate, flexible, ribbon-shaped substrate coupled to the elongate cutting members of the tissue modification region, wherein the substrate is sized and configured to temporarily hold the cutting members a distance from one another. In

some embodiments, the substrate further comprises a coupler toward the outer edge region of the substrate and configured to temporarily secure a cutting member to the outer edge region of the substrate.

In some embodiments, a bimanually controlled tissue modification device having a tissue modification region for cutting tissue in a patient may include a pair of flexible elongate cables extending along the length of the tissue modification region, wherein at least one of the cables is configured to be a cutting member; and an elongate, flexible, ribbon-shaped substrate coupled to the elongate cables of the tissue modification region, wherein the substrate is sized and configured to temporarily hold the one cutting member a distance from the other cable; wherein the one cutting member is configured to decouple from the substrate such that the cutting member cuts a discrete trough into tissue to a depth that is greater than the thickness of the cutting member.

In some embodiments, when the one cutting member is decoupled from the substrate, it is positioned out of the plane of the substrate. In some embodiments, the device further includes a coupler positioned toward an outer edge region of the substrate, and configured to removably couple the one cutting member to the outer edge region of the substrate. In some embodiments, the one cutting member decouples from the substrate as the cutting member cuts through the coupler. In some embodiments, the coupler comprises a deformable material sized and configured such that the substrate decouples from the cutting member as the deformable material deforms and a portion of the substrate moves with respect to the cutting member. In some embodiments, the device may further include a spring coupled to the substrate and one elongate cable, wherein the spring is configured to expand as the cutting member cuts a discrete trough into tissue. In some embodiments, the at least one cutting member is sized and configured to cut a first depth into the tissue while the substrate is coupled to the cutting member and to cut a second, greater depth into the tissue when the substrate decouples from the cutting member.

In some embodiments, the device may further include a guidewire coupler distal to the tissue modification region of the device. In some embodiments, the guidewire coupler is configured to be coupled to a guidewire, and wherein the tissue modification region is configured to be actuated by a proximal handle and a guidewire. In some embodiments, the tissue modification region is configured to be actuated by a proximal handle and a distal handle. In some embodiments, the guidewire coupler is configured such that the device is removably attachable to a proximal end region of a guidewire such that the tissue modification region can be pulled into position by pulling on the guidewire while the proximal end region of the guidewire is held stationary by the guidewire coupler with respect to the device. In some embodiments, wherein the cutting member comprises a cutting wire. In some embodiments, the cutting member comprises an elongate wire having a helical cutting edge along the length of the wire.

Also described herein are methods of modifying tissue. In some embodiments, the methods may include the steps of passing an elongate, flexible tissue-modification device at least partially around a target tissue, moving a tissue-modification region of the device against the target tissue by pulling the tissue-modification device from at least one end of the device; and cutting a single discrete elongate trough into the tissue with a cutting member, wherein the cutting member is one of a pair of flexible elongate cables extending along the elongate length of the tissue modification region, wherein the

elongate cutting member has a thickness and the elongate trough is cut to a depth that is greater than the thickness of the cutting member.

In general, the tissue-modification devices described herein include a flexible elongate body having a tissue modification region. The tissue modification region may include a plurality of parallel cutting wires. In general, these devices may also include a guidewire coupler at the distal end region of the elongate body and a plurality of connected rungs. In some embodiments, at least some of the rungs may include one or more cutting edges (e.g., blades), that may project from the rung. The rungs may be connected by a flexible material, such as cable, that extends along the length of the device. These devices are typically configured so that they can be used in the narrow region of a spinal foramen. Thus, the devices may be substantially flat. For example, the devices may be substantially ribbon-shaped. These devices may also include a distal attachment site for a guidewire. Thus, a guidewire may be used to pull a device from the distal end of the device into position, and may also be used to tension the device so that it is urged against the tissue.

For example, described herein are bimanually controlled tissue modification devices for removing tissue from a patient. In some embodiments, the devices include a flexible elongate body; a tissue modification region of the elongate body, the tissue modification region comprising a plurality of parallel cutting wires distributed across the tissue modification region; and a guidewire coupler at the distal end region of the elongate body.

Also described herein are flexible tissue-modification devices for removing tissue from a patient. In some embodiments, the devices include a flexible elongate body having an axial length, a width and a thickness, wherein the axial length is greater than the width, and the width is greater than the thickness. In some embodiments, the elongate body includes a tissue modification region comprising a plurality of parallel cutting wires distributed across at least a portion of the width of the elongate body, and a plurality of rungs, positioned proximal or distal to the tissue modification region, that are flexibly connected, wherein each rung extends at least partially across the width of the body.

Also described herein are flexible tissue-modification devices for removing tissue from a patient. In some embodiments, the devices include a flexible elongate cable that extends from the proximal end of the device to the distal end of the device and back toward the proximal end of the device; a rung that extends across at least two parallel portions of the cable; and at least one cutting edge on least two parallel portions of the cable.

Also described herein are methods for modifying tissue. In some embodiments, the methods include the steps of passing a distal end of a tissue modification device in a first direction toward a target tissue, at least partially around a target tissue, and away from the target tissue, such that a tissue modification region on the tissue modification device is positioned adjacent to the target tissue; moving the tissue modification region against the target tissue by pulling the tissue-modification device from at least one end of the device; and cutting the target tissue with cutting wires of the tissue modification region of the tissue modification device.

BRIEF DESCRIPTION OF THE DRAWINGS

FIGS. 1A-1D illustrate elements that may be used for performing the methods described herein; some or all of these elements (the guidewire of FIG. 1A, neural localization

device of FIG. 1C, flexible wire saw of FIG. 1B, and parallel wire saw of FIG. 1D) may form a system for cutting tissue.

FIGS. 2-3D show various embodiments of a cutting wire.

FIG. 4 illustrates a tissue modification device having a cutting wire.

FIG. 5 illustrates a method for cutting a lateral portion of a facet.

FIG. 6A illustrates a variation of a method for cutting the lateral portion of a facet.

FIG. 6B illustrates one step of a method for cutting a facet.

FIGS. 7-11 illustrate variations of a tissue modification device having a pair of elongate cutting members.

FIGS. 12-14B illustrate tissue modification devices having shaped wires.

FIG. 15 shows another variation of a tissue modification device having a pair of elongate cutting members.

FIGS. 16A-18D illustrate tissue modification devices having spacers.

FIGS. 19A-19B illustrate a variation of a rung of the tissue modification device having a U-shaped cross section.

FIGS. 20A-20B illustrate another variation of a rung of the tissue modification device having a U-shaped cross section.

FIGS. 21A-29 illustrate additional variations of the cutting devices and regions of cutting devices described herein.

FIG. 30A illustrates a cross-section through one variation of a facet joint modifying device that includes two bone-sawing elements.

FIG. 30B illustrates a cross-section through one portion of the device having a breakable spacer.

FIG. 30C shows a top view of one variation of a facet joint modifying device configured to perform a facetectomy.

FIGS. 31A-31E illustrate variations of joint treatment devices. In FIG. 31A, the treatment device includes a front and a back articulating surface that can be drawn across the joint surfaces to roughen them; FIGS. 31B-31D show different cross-sections through joint treatment devices, and FIG. 31E illustrates another variation of a joint treatment device. Any of these joint treatment devices may be facet joint treatment devices.

FIG. 32 illustrates a facet joint including the superior and inferior articulating processes.

FIGS. 33-35 illustrate multiple variations of a tissue modification device as described.

FIG. 36 illustrates one variation of an expanding mechanism as described.

FIGS. 37-41D illustrate other variations of expanding mechanisms as described.

FIG. 42 illustrates one variation of a tissue modification device having a shield as described.

FIG. 43 illustrates another variation of a device and method for modifying tissue as described.

FIG. 44 illustrates a delivery device as described herein.

FIGS. 45A-46C illustrate another variation of a device and method for modifying tissue.

FIG. 47 illustrates another variation of a device and method for modifying tissue.

FIGS. 48-52C show various embodiments of a flexible tissue modification device including a plurality of cutting wires.

FIGS. 53A-53D show various embodiments of a cutting wire.

FIGS. 54A-54C illustrates one variation of an osteotomy.

DETAILED DESCRIPTION

Described herein are devices, systems and methods for cutting spinal tissue such as bone and/or soft tissue, and

particularly spinal bone in the dorsal column using a flexible cutting element that may be passed around the bone. In some embodiments, these devices, methods and systems may be used to cut two substantially parallel cuts into tissue without requiring the removal of the cutting element between cuts. The methods, devices and systems described herein may be used as part of a spinal surgical procedure involving a complete or partial removal of spinal bone or joint, such as a laminectomy, laminotomy, fascetectomy, pediclectomy, etc.

FIGS. 1A-1D illustrate different elements that may be used as part of a system for cutting bone as described. FIG. 1A shows a guidewire **100** that is adapted to couple to the distal end of another device so that the device may be pulled into position using the guidewire. The distal end **101** of the guidewire may be sharp, and the proximal end may include a coupling joint **102** (e.g., a ball or other enlarged region that can be gripped by a coupling member).

FIG. 1B shows one variation of an elongate cutting member, such as a cutting wire **103** having an abrasive surface for cutting tissue, such as soft tissue (e.g. ligament) and/or bone. Such saw wires (e.g., traditional Gigli saws) may be adapted for use with a guidewire. For example, the distal end of the saw may include a guidewire coupler **104**. In some variations the wire is thin or flattened. Any appropriate saw or cutting element may be used, including those that cut by reciprocation or by application of energy.

FIG. 1C illustrates one variation of a flexible ribbon-shaped neural localization device **105**. The distal end **106** of the device is substantially flat (not apparent from the figure) and has flat sides with one or more electrodes **107** along the surface to stimulate a nerve or neural tissue, if nearby.

FIG. 1D illustrates another variation of a bone saw device having two parallel cutting wires **108** that are separated by a predetermined distance (e.g., 4 mm, 5 mm, 6 mm, 7 mm, 8 mm, 9 mm, 10 mm, 11 mm, 12 mm, 13 mm, 14 mm, 15 mm, 16 mm, 17 mm, 18 mm, etc.). The distal end of the device may be configured for coupling to a guidewire **100**. Alternatively, the device may have an integral flexible guide region **109** at the distal end of the device so that the device does not need any additional guidewire/coupler. For example, flexible guide region **109** is shown having a curved shape to demonstrate that at least a portion of flexible guide region **109** may be flexible. The distal portion is preferably flexible in at least one direction, such that it may wrap around a target tissue, while having sufficient column strength such that the distal end may penetrate tissue without buckling. In some embodiments, the distal end may have a sharp distal tip configured to penetrate and/or pierce tissue. In various embodiments, flexible guide region **109** may have one or more of a round, ovoid, ellipsoid, flat, cambered flat, rectangular, square, triangular, symmetric or asymmetric cross-sectional shape. Distal flexible guide region **109** may be tapered, to facilitate its passage into or through narrow spaces as well as through small incisions on a patient's skin. Distal flexible guide region **109** may be long enough to extend through a first incision on a patient, between target and non-target tissue, and out a second incision on a patient. In some embodiments, the distal end may have a length greater than or equal to 3 inches such that it may extend from around the proximal end of the stimulation region to outside the patient where it may be grasped by a user and/or a distal handle. In some alternative embodiments, the distal end may have a length greater than or equal to 10 inches while in some other alternative embodiments, the distal end may have a length greater than or equal to 16 inches. Alternatively, distal flexible guide region **109** may be long enough to extend through a first incision, between the target and non-target tissue, and to an anchoring location within the patient.

The cutting wires **108** as described herein may be one of several variations of cutting wires. In some embodiments, the cutting wires may have an outer diameter that ranges from 5 to 50 thousandths of an inch, for example. A single wire saw may include a plurality of wires wrapped around each other at differing pitches. As shown in FIG. 2, wire **202** having a first diameter, may be wrapped around wire **201** having a second diameter. As shown, the first diameter may be less than the second diameter. FIG. 2 illustrates one example of a Gigli cutting wire. Alternatively, as shown in FIGS. 3A-3D, the cutting wire of the tissue modification device can be one of several alternative embodiments. For example, as shown in FIG. 3A, the cutting wire may be a second embodiment of a conventional Gigli wire. A Gigli wire is typically made of a first wire having a first diameter wrapped around a second wire having a second diameter. Typically, the second diameter is larger than the first diameter, but alternatively, they may have substantially the same diameter, as shown in FIG. 3A. In some embodiments, a first set of first and second wires may be wrapped around a second set of first and second wires. Alternatively, as shown in FIG. 3B, the cutting wire may include a single wire that is machined to include a helical or spiral cutting edge along the length of the wire. This wire may be machined by cutting a spiral or helical groove along the length of the wire. As shown in FIGS. 3C and 3D, the cutting wires may be formed by winding bunches of wires. For example, as shown in cross section in FIG. 3D, the cutting wire may comprise a 3 by 3 construction. In this embodiment, three wires are first wrapped around one another to create a first bunch of wires. Then three sets of those three wire bunches are subsequently wrapped around each other. As shown in cross section in FIG. 3C, rather than initially wrapping three wires together, 6 wires may be wrapped together to create a bunch of wires and then three sets of the 6 wire bunches may be wrapped together to form a 3 by 6 configuration. Each 6 wire set may be formed as a 7 wire set might be formed, but leaving one wire position empty.

As shown in FIG. 4, a tissue modification device **400** includes a tissue modification portion **401**, a distal end **402**, and a proximal end **403**. The tissue modification portion may include a wire saw configured to cut through bone and/or soft tissue. The distal end **402** may include a guidewire coupler. The proximal end **403** may be more rigid than the flexible tissue modification region **401**. The proximal end may be coupled to a proximal handle used to grasp, position, and/or reciprocate the tissue modification device.

In operation, the devices described above may be used as part of a system for cutting bone, as illustrated in FIGS. 5-6B. In this example, the facet is cut laterally, which may be used as part of a TLIF procedure, for example. FIG. 5 shows an overview of this method. In this example, two cuts through the bone are made sequentially. To cut the facet joint as desired for this procedure, a guidewire is first positioned partially around/against a superior articular process (SAP) **500** that will be cut. The guidewire may be positioned using or more probes or cannula so that the guidewire enters laterally from a first position (A) passes through the foramen and around the SAP **500**, and leaves the spine (and exits the patient) at a second position (A'). Once the guidewire is positioned, it may be used to pull in a neural localization device to confirm that a nerve (spinal nerve or nerve root) is not between the bone to be cut and the pathway of the guidewire. After confirmation that the nerve is not between the bone and the pathway, a cutting element (e.g., wire saw **1B**) may be pulled into position so that both the distal and proximal ends of the wire saw exit the patient and may be

pulled upward (in the posterior direction) and reciprocated laterally to cut the SAP as indicated by the dashed line **501** in FIG. **5**.

Once the SAP has been cut by the saw, the saw may then be positioned for the second cut, through the lamina. Optionally, before this cut is made, and before the wire saw is moved to this location, the lamina may be prepared by notching or biting away portion of the lamina **502** with a Rongeur or other device (e.g. forming a laminotomy). For example, in FIG. **5**, the dotted region shows an area **502** that may be bitten away to form a partial window into the lamina. Once that is done, the cutting element (wire saw) is moved in the cephalid direction (down in the orientation of FIG. **5**), so that the ends of the wire extend in the cephalid direction (and across the central spinal axis). Thus, one end of the saw B is present in the notch or window formed in the lamina, and the other end B' moves along the foramen. If desired, the neural localization device may again be used to confirm that a nerve will not be cut from this position, e.g., by retracting the guidewire proximally, removing the cutting element and attaching the neural localization device. Finally, the cutting element may be reciprocated to cut through the pars region of the lamina along dotted line **503**. Thereafter the cut away portion of the bone may be removed, and other procedures performed as desired.

In the embodiments including two parallel wires, the facet or target tissue suture may be cut in a single step. For example, to perform a Facetectomy, the device may be deployed just cephalad of the caudal pedicle. The parallel wires may be held at the desired width, or the wires may be expanded to the desired width. The desired width may range from 6 mm-15 mm, depending on the interbody device to be inserted between the vertebrae, for example. In some variations, the cephalad wire may be expanded to the desired width. The device may then be reciprocated across the tissue to cut through and remove at least a portion of the width of the facet joint. The device may be reciprocated by alternatively pulling a proximal end of the device (e.g. proximal handle) and pulling a distal end of the device (e.g. a distal handle and/or or guidewire). While one end is pulled, the other end may also be pulled to maintain tension across the device.

FIGS. **6A** and **6B** illustrate alternative views of the steps described above. For example, FIG. **6A** shows the steps of cutting through the SAP **600** (dotted line **601**), biting away/ forming a window **602** in the lamina, moving the cutting element in the caudal direction (arrow **603**) and cutting the pars (dotted line **604**). FIG. **6B** shows a cross-sectional view through the spine indicating the cutting of the SAP. As shown, the cutting wire **600** is positioned through the foramen and around the SAP (not shown). The wire will be reciprocated and pulled in the direction of the arrows to cut through the SAP.

As mentioned above, in any of the facet joint procedures described herein, all or a portion of the facet (e.g., the superior and/or inferior spinous processes) may be cut. For example, a procedure for fusing or preparing a facet joint may include a facetectomy, particularly for TLIF (Transforaminal Lumbar Interbody Fusion) procedures. The procedure may include a facet joint treatment device that is configured to saw through bone. For example, the device may include one or more cable-type saws including a distal end that is configured to couple to the pull wire as described above. As mentioned, a probe or probes may be used to place the pull wire under the facet joint. A facet joint modifying device may then be pulled in under bimanual control. Pulling the facet joint modifying device dorsally (e.g., by distal/proximal reciprocation) would

result in the removal of the entire facet joint. This method may be faster than current methods which involve slow biting with Rongeur-type devices.

Tissue Modification Device Having Two Elongate Cutting Members

In some embodiments of the devices, systems and methods for cutting tissue in a patient described herein, a tissue modification region of a device includes a pair of flexible elongate cutting members extending along the length of the tissue modification region. Each elongate cutting member may be configured to cut a separate trough into tissue to a depth that is greater than the thickness of the cutting member.

In a first embodiment, the tissue modification device (e.g., bone saw) may include cutting edges directly coupled to a cable, as shown in FIG. **7**, the cable **701** may include cutting elements **703** such as beads, blades, wires, or other suitable cutting elements. In some embodiments, the cutting elements may be crimped onto the wire or attached by other suitable methods. The cutting cables may cut tissue using an energy such as heat or radio frequency energy. The energy may function to desiccate and/or shrink the tissue, rather than cutting it. As shown in FIG. **7**, a portion of the device may include cutting cables **701**, while a portion of the device includes spacers or rungs **702** threaded onto cables (with or without cutting edges on the spacers). The cutting cables and the cables onto which the spacers are threaded may be the same or different cables.

As shown in FIG. **8**, a tissue modification device **800** includes a tissue modification portion **801**, a distal end **802**, and a proximal end **803**. The tissue modification portion may include two parallel wire saws **805** configured to cut through bone and/or soft tissue. The distal end **802** may include a guidewire coupler. The proximal end **803** may be more rigid than the flexible tissue modification region **801**. The proximal end may be coupled to a proximal handle used to grasp, position, and/or reciprocate the tissue modification device. The proximal end **803** may include a proximal connector element **804** that couples the proximal end **803** to the parallel wire saws **805**. In some embodiments, the tissue modification portion **801** may include a single wire saw that is coupled at one end to the distal end, fed through the proximal connector element **804**, and coupled at a second end to the distal end. The cutting wire may be configured to slide through the proximal connector element and to be movable with respect to the proximal end **803**. FIG. **9** shows the tissue modification device positioned within a spine. As shown, the surfaces of the spine about which the device is positioned may be uneven. In some instances, the device may not contact the surfaces of the spine in a balanced way, or may not be taut against the surface to be cut. As shown in FIGS. **9** and **10**, the proximal connector element (labeled **904** and **1004**, respectively) ensures that the cutting wire can slide through the connector element and be repositioned such that both parallel portions of the cutting wires can be taut against the tissue to be cut.

In an alternative embodiment, as shown in FIG. **11**, the tissue modification device may include a pulley **1101**. The pulley is coupled to the cutting wire **1102** and may be positioned at the proximal and/or the distal end of the tissue modification device. The pulley may be configured to reposition the cutting wire such that both parallel portions of the cutting wires can be taut against the tissue to be cut.

As shown in FIG. **12**, a tissue modification device **1200** includes a tissue modification portion **1201**, a distal end **1202**, and a proximal end **1203**. The tissue modification portion may include two parallel wire saws **1205** configured to cut through bone and/or soft tissue. The distal end **1202** may include a guidewire coupler. The guidewire coupler may be

coupled to a guidewire (which may be coupled to a distal handle) and may be used to grasp, position, and/or reciprocate the tissue modification device. The proximal end **1203** may be more rigid than the flexible tissue modification region **1201**. The proximal end may be coupled to a proximal handle used to grasp, position, and/or reciprocate the tissue modification device. The proximal end **1203** may include a proximal connector element **1204A** that couples the proximal end **1203** to the parallel wire saws and the distal end **1202** may include a distal connector element **1204B** that couples the distal end **1202** to the parallel wire saws. In some embodiments, the tissue modification portion **1201** may include a single wire saw that is fed through the proximal connector element **1204A** and the distal connector element **1204B**. The cutting wire may be configured to slide through the connector elements. As shown, the connector elements are configured to hold the cutting wires apart from one another. In some variations, the wires are held a distance apart that is greater than the minimum desired width such that if some approximation of the cutting wires **1205** does occur during positioning and/or reciprocation of the device (due to the geometry and/or anatomy of the spine, for example), the wires will still be at least the minimum desired width apart. In some variations, the connector elements are made from a flexible or shape memory material such as Nitinol. In this variation, if the connectors are compressed, such that the leg portions of the connectors are brought closer to one another, the connector legs will be biased apart and will return to their original configuration.

In an alternative variation, as shown in FIGS. **13A** and **13B**, a tissue modification device **1300** includes a tissue modification portion **1301**, a distal end **1302**, and a proximal end **1303**. The tissue modification portion may include two parallel wire saws configured to cut through bone and/or soft tissue. The distal end **1302** may include a guidewire coupler. The guidewire coupler may be coupled to a guidewire (which may be coupled to a distal handle) and may be used to grasp, position, and/or reciprocate the tissue modification device. The proximal end **1303** may be more rigid than the flexible tissue modification region **1301**. The proximal end may be coupled to a proximal handle used to grasp, position, and/or reciprocate the tissue modification device. In some variations, the cutting wires are made from a flexible or shape memory material such as Nitinol. As shown in FIG. **13A**, the wires in their equilibrium or biased configuration are held a first distance **A** apart. Distance **A** is wider than a minimum desired width. In this variation, if the cutting wires are compressed, such that the cutting wires are brought closer to one another, the cutting wires will be biased apart and will return to their original, wider configuration. As described, the wires are held a distance apart that is greater than the minimum desired width such that if some approximation does occur, the wires will still be at least the minimum desired width apart. In operation, a guidewire may be coupled to distal end **1302** such that the tissue modification device can be alternatively pulled by the guidewire and the proximal end of the device. As shown in FIG. **13B**, as the device is pulled and reciprocated, it is possible that the wires will approximate toward one another to a width **B** as the tissue modification portion **1301** is elongated. Width **B** is preferably at least as wide as the minimum desired width. In some variations, the device may further include a length limiting element **1304**. As shown in FIG. **13A**, the length limiting element is flexible and not pulled taut. In FIG. **13B**, as the device is pulled and reciprocated, the tissue modification portion **1301** is elongated only to the length of the length limiting element **1304**. The length limiting element **1304** is configured such that the tissue modifica-

tion portion **1301** cannot be elongated such that width **B** is too small. Width **B** is preferably at least as wide as the minimum desired width. Alternatively, in some variations width **C** is preferably at least as wide as the minimum desired width.

In some embodiments, as shown in FIGS. **14A** and **14B**, the cutting wire may have a cross section that is configured to limit the flexibility in the orthogonal direction and therefore limit approximation of the wires. As shown in FIG. **14B**, the wider, substantially rectangular cross section is less susceptible to an orthogonal load as shown.

Tissue Modification Device Having a Spacer

In some embodiments, a tissue modification region of a cutting device includes a pair of flexible elongate cutting members extending along the length of the tissue modification region and also includes a spacer. Each elongate cutting member may be configured to cut a discrete trough into tissue to a depth that is greater than the thickness of the cutting member. A spacer may generally span the width between the two cutting members holding them some predetermined (or adjustable) distance apart. Since the spacers do not typically cut the tissue, they may be configured so that they do not substantially inhibit the cutting gwires or edges from cutting the tissue. The spacer may be sized and configured to operate in one of two modes. A first mode, in which the spacer is coupled to the cutting members such that it holds a portion of each of the two cutting members a distance from one another, and a second mode, in which at least a portion of the spacer is moved away from a cutting member to allow the cutting members to cut further into tissue.

Referring again to FIG. **9**, in some embodiments, the uneven or curved surfaces of the spine may cause the elongate cutting members **901** to approximate at the apex of the curve and/or the anterior portion of the facet joint, for example. If the wires approximate to a substantial degree, the width of tissue cut and/or removed by the device may not be as wide as desired or required for the specific procedure. For example, if the wires are too close to one another, they may not be able to cut around the facet joint and the entire facet joint may not be removed. In these cases, it may be advantageous to provide a tissue modification device further including a spacer, as described in detail below.

FIG. **15** shows another variation of a parallel wire saw, in which the parallel wires **1500** and **1501** are held a minimum distance apart. Thus, although the device is flexible, it is desirable to have the distance between cutting wires (and thus the width of the bone chunk being cut away) a predetermined length apart. In FIG. **15**, one or more spacers **1502** may hold the cutting wires apart. The spacers may be removed (e.g., by breaking away or by separating from one side of the device) during reciprocation, or they may be expandable (but not very compressible) so that they may allow the cutting regions to bite into the bone while expanding.

FIGS. **16A-18D** illustrate an alternative embodiment of a tissue modification device **1600** having a pair of flexible elongate cutting members **1601** and a spacer **1602**. As shown in FIG. **16A**, the tissue modification device includes a distal end having a tissue modification region and a proximal end **1605** having, in some embodiments, a proximal handle **1604**. The distal tissue modification region includes the pair of flexible elongate cutting members **1601** and the spacer **1602**. As shown, a guidewire coupler **1608** may be at the distal end of the tissue modification device. The guidewire coupler may be configured to attach to a guidewire (e.g., the proximal end of a guidewire) so that the device can be manipulated (e.g. reciprocated), at least in part, by pulling on the guidewire after the guidewire has been secured to the device. As shown in FIG. **16A** and in greater detail in FIG. **16B**, the spacer **1602**

may further include passive restraints **1609** coupled to the outer edges of the spacer. As shown, portions of these restraints are coupled to cutting member **1601**. These restraints may function to hold the cutting wires toward the outer edges of the device and/or prevent the wires from approximating. As shown, the restraints may not run the entire length of the tissue modification region of the device. This may be desirable such that a portion of the cutting wires **1601** are exposed. These exposed wires may provide cutting action during the initial reciprocations of the tissue modification device against the tissue. As the device is pulled back and forth (i.e. reciprocated) across the tissue, the exposed portions of the cutting wires **1601** will begin to cut through the bone and/or soft tissue. In some embodiments, the device is pulled “up” (toward the back of the patient) and against the tissue while the device is reciprocated across the tissue. Due to this upward pressure, the cutting wires will begin to cut into the tissue and create troughs into the tissue. As the initial troughs are formed in the tissue, and the cutting wires move deeper into the tissue, the cutting wires will eventually detach from the restraints **1609**. In some embodiments, the restraints are made from an elastic or otherwise deformable material such that the upper lip (labeled **1707** in FIG. **17B**) of the restraint can deform to allow the cutting wire to pull out of the restraint. Alternatively, the cutting wire may cut through or break off a portion (e.g., the upper lip) of the restraint.

Returning to FIG. **16A**, the tissue modification device further includes a spring **1603**. This spring may function to couple the shield **1602** to the proximal end **1605** of the tissue modification device. As the cutting wires **1601** cut into the tissue, and the spacer **1602** moves away from the cutting wires, the spring **1603** will stretch and allow the proximal end of the spacer (labeled **1802** in FIGS. **18A-18C**) to move toward the distal end of the device such that the distal end of the spacer may bend and move away from the cutting wires **1601**. Also, as shown in FIG. **16A**, the tissue modification device may optionally include rungs **1607**. These rungs may thread over the wires that run the length of the device. The rungs may be positioned distal and/or proximal to the tissue modification region of the device. In some embodiments, the spacer may be connected to a rung(s) positioned distal to the tissue modification region.

As shown in FIG. **16C**, the distal end of the device may include rungs **1607**. Alternatively, as shown in FIG. **16D**, the distal end may be a substrate without rungs. In some embodiments, the substrate at the distal end may be an extension of the spacer **1602**, or it may be a separate component. In some embodiments, the wires or cables that extend along the length of the device, may run through the distal rungs **1607**, or alternatively, they may stop at the proximal end of the tissue modification region as shown in FIG. **16D**.

FIGS. **17A** and **17B** illustrate in detail the passive restraint **1700** at the edge of the spacer as described above. As shown in FIG. **17A**, the restraint includes an upper lip portion that couples to the cutting wire and temporarily holds the cutting wire in position, a distance from the other cutting wire. The upper lip defines channel **1703** in which the cutting wire may be temporarily held. The restraint may also include a base portion that may function to couple the restraint **1700** to the spacer of the tissue modification device. As shown in FIG. **17B**, the base portion **1702** of the restraint may define channel **1704**. This channel may be sized and configured to receive the outer edge of the spacer. As shown in FIG. **16B**, the spacer may include two passive restraints, one coupled to each edge of the spacer. In some embodiments, the restraint may be extruded or molded and then may be coupled to the spacer

using adhesive, UV glue, or any other suitable coupling mechanism. Alternatively, the restraint may be over-molded directly to the spacer.

FIGS. **18A-18D** illustrate in detail the components of one embodiment of the tissue modification device. As shown in FIG. **18A**, the tissue modification device includes a spacer **1800** and at least one restraint **1801** coupled to the outer edges of the spacer. The spacer includes a distal portion **1800** positioned within the tissue modification region of the device, adjacent to the cutting wires (labeled **1803** in FIGS. **18B-18D**), and a proximal portion **1802**. In this embodiment, the distal end of the spacer **1800** is fixed to the distal end of the device and the proximal end **1802** is movably coupled to the proximal end of the device via a spring (labeled **1808** in FIGS. **18C** and **18D**). In some embodiments, the tissue modification region of the device may range from 1 cm to several inches long. The tissue modification region is preferably long enough to reciprocate against and cut through a facet joint, for example. In some embodiments, a longer tissue modification region may have the added benefit of increased fatigue life of the cutting wires due to distributing the cutting load across longer wires. Alternatively, it is also desirable to design the tissue modification region such that it is not so long that the cutting wires will approximate toward one another and adversely affect the effectiveness of the device.

As shown in FIG. **18B**, the device further includes cutting wires **1803**. As shown, the cutting wires are positioned (at least initially) adjacent to the restraints **1801**. In this embodiment, the device may also include cables **1804** toward the distal end of the device and **1805** toward the proximal end of the device. As shown, in this embodiment, cutting wires **1803** and cables **1804**, **1805** are all one continuous cable that runs from the proximal end to the distal end, through the guidewire coupler **1806** at the distal end of the device, and back to the proximal end. In some embodiments, the cutting wire portion of the cable may include blades or other suitable cutting edges. In some embodiments, the cutting edges may be sanded down or otherwise removed from the non-cutting portions of the cable (**1804**, **1805**). Alternatively, cables **1804**, **1805** may be different cables or different materials coupled to cutting wires **1803**. Furthermore, the single continuous cable may not wrap all the way through the distal end of the device. Alternatively, a separate cable may loop through the distal end of the device (rungs **1809** in FIG. **18D**) and the distal end may be coupled to the tissue modification region of the device with a separate coupling mechanism. Alternatively there may not be a cable in the distal or proximal ends of the device.

As shown in FIG. **18C**, the device may include a proximal end **1807** and a spring **1808**. As described above, the spring **1808** may function to movably couple the proximal end of the spacer **1802** to the proximal end of the device **1807** such that the spacer may move with respect to the cutting wires **1803**. As shown in FIG. **18D**, in some embodiments, the device may further include distal rungs **1809** and distal rungs **1810**. These rungs may function to add structure to the device while maintaining thinness and flexibility.

In some embodiments, as shown in FIG. **19A**, the spacer may have a “U” shape (e.g. a rounded or a squared off U-shape). The spacer may include two leg portions **1901** and a base portion **1902**. The leg portions may be perpendicular to the base portion, or may be configured in any other suitable fashion. The leg portions may be substantially straight, or may have a curved configuration. The spacer may define an opening **1904** through which a cable **1905** or other connector may be threaded. In some embodiments, the spacer may include a cutting edge **1903**. The cutting edge may be coupled to the leg portions of the spacer above the opening **1904**. As

shown in FIG. 19B, the U-shaped spacers may function to allow the legs of the spacers to pass through tissue 1908, such as ligament and bone, as the cutting edges cut through the tissue, such that the base portion of the spacer does not catch on the tissue or otherwise obstruct the cutting of the tissue. As shown, a number of U-shaped spacers may be coupled to a cable to form a modification device. In some embodiments, secondary spacers 1906 may be coupled to the cable between two adjacent U-shaped spacers. The secondary spacers 1906 may include a cutting edge 1907.

In some embodiments, the leg portions may be flexible. As shown in FIGS. 20A-B, the leg portion 2001 of the U-shaped spacer may be made from an expandable or stretchable material, such that as the cutting edge 2002 cuts through a tissue, the cutting edges and leg portions may extend further into the tissue (FIG. 20B), while the base portion 2002 remains on the surface of the tissue and does not catch on the tissue or otherwise obstruct the cutting of the tissue.

In some embodiments, the device further includes a sheath that covers the cutting edges while the device is being introduced into a patient. Once the device has been introduced, the sheath may be removed. In some embodiments, the sheath further functions to remove the cut tissue.

In some embodiments, as shown in FIGS. 21A-21C, a spacer element 2101 may be removably coupled to the cutting wires 2102 of the tissue modification device. The spacer element may be coupled to the cutting wires by a combination of sliding elements 2103 and/or breakaway elements 2104. The spacer may be flexible, rigid, or semi-rigid. Preferably, the spacer is rigid enough in the direction perpendicular to the width of the spacer to prevent the cutting wires from approximating closer to one another than a desired width. For example, a desired width may be 8-15 mm, i.e. the width of an interbody device and/or the width or thickness of a facet joint. The spacer 2101 may be flexible in the longitudinal direction and less flexible along its width. In some embodiments, as shown in FIGS. 21B and 21C, the spacer may be made of a silicone material or other suitable polymer. In use, the spacer may initially be coupled to the cutting wires by both sliding elements 2103 toward the ends of the spacer and by breakaway elements 2104 toward the center of the spacer, as shown in FIGS. 21A and 21B. The breakaway elements may be slidably attached or fixed to the cutting wires. The spacer is configured to maintain the distance between the cutting wires while the wires are positioned within the patient and during the initial reciprocations of the tissue modification device against the tissue. As the device is pulled back and forth (i.e. reciprocated) across the tissue, the exposed portions of the cutting wires 2102 will begin to cut through the bone and/or soft tissue. In some embodiments, the device is pulled "up" (toward the back of the patient) and against the tissue while the device is reciprocated across the tissue. Due to this upward pressure, the cutting wires will begin to cut into the tissue and create troughs into the tissue. As the cutting wires cut tissue, they will also cut through the breakaway elements 2104, such that the spacer is released from the breakaway elements, as shown in FIG. 21C. An additional benefit to cutting troughs, as will be described throughout, is that by burying the cutting elements within the troughs created in the tissue the neural and vascular structures (i.e. non-target tissue) will have limited exposure to the cutting wires. Alternatively, the breakaway elements may release the cutting wires independently and are not necessarily cut by the cutting wires. Once the spacer is released by the breakaway elements, the spacer may be permitted to slide along the cutting wires at the sliding elements 2103. This feature is desirable in order to allow the ends of the spacer to slide toward one another along

the length of the wires such that the center of the spacer moves away from the cutting wires, as shown in FIG. 21C. This allows the cutting wires to cut deeper into the tissue without the spacer preventing or blocking the wires from cutting all the way through the tissue. Additionally, the spacer may be configured to catch or carry the cut and/or removed tissue in the space created between the spacer and the cutting wires.

FIGS. 22A-22B illustrate a side view of an alternative variation of a spacer between the cutting wires. As shown, the spacer 2201 is coupled to the cutting wires (only a single wire 2202 is shown) via a sliding coupler 2203 and a fixed coupler 2204. Sliding coupler may be located a distance y from the fixed coupler. Alternatively, both couplers may be slidably connected to the cutting wire 2202. As the cutting wires are reciprocated across the tissue, the cutting wires begin to cut into the tissue creating troughs into the tissue. As the cutting wires enter deeper into the tissue, the spacer rides along the outer surface of the tissue (substantially between and/or below the troughs being cut into the tissue). The spacer must therefore separate from the cutting wires such that the cutting wires can continue to cut deeper troughs and move into the tissue without being restricted by the spacer. The sliding end 2203 of the spacer slides toward the fixed end 2204 of the spacer such that distance Y is reduced to Y' and such that distance X between the center of the spacer and the cutting wire increases as shown in FIG. 22B.

As shown in FIGS. 23A-23C, a rigid (or semi-rigid) spacer 2301 may be coupled to the cutting wires 2304 via at least one flexible portion 2302. The flexible portion 2302 may be fixed to the cutting wire by coupling element 2303. Coupling element 2303 may fix the flexible portion 2302 to the cutting wire 2304, but may alternatively slidably couple the flexible portion to the cutting wires. As described above, the rigid spacer is configured to hold the cutting wires at a desired width. The spacer will hold the wires apart while the device is positioned and while the initial cutting occurs. As shown in cross sectional view and axial view in FIGS. 23B and 23C respectively, as the cutting wires 2304 cut deeper into bone 2305 (or other tissue), the tissue (specifically tissue section 2307) prevents the spacer from entering into troughs 2306 formed by the cutting wires 2304. The spacer therefore "pops" off of and/or away from the cutting wires 2304, thereby stretching flexible portion 2302. As shown in FIG. 23C, the spacer remains exterior to the target tissue as the cutting wires cut deeper into the target tissue. For example, tissue section 2307 may include a facet joint. As the cutting wires are reciprocated and moved up through the tissue, eventually the section 2307 of tissue will be completely cut away from the remainder of the tissue 2305.

FIG. 24A illustrates a top view of a tissue modification device, and FIG. 24B illustrates a rear view of the same tissue modification device. The device shown may be inserted into a spine and around a facet joint, for example, such that the top portion of the device (FIG. 24A) faces target tissue (e.g. a facet joint) and the bottom portion of the device (FIG. 24B) faces non target tissue (e.g. neural or vascular tissue). As shown in FIGS. 24A and 24B, a rigid (or semi-rigid) spacer 2401 may be coupled to the cutting wires 2404 via at least one flexible portion 2402. As shown, the flexible portion may extend the length of the tissue modification device such that the spacer 2401 may be coupled to the back side of the flexible portion, as shown in FIG. 24B. The flexible portion, in this variation, is fixed to the tissue modification device at positions 2403. As described above, the spacer is configured to hold the cutting wires at a desired width. The spacer will hold the wires apart while the device is positioned and while the initial cutting occurs. In this variation, the spacer 2401 is

25

coupled to the cutting wires **2404** by breakaway elements **2415**. As described above, the breakaway elements may be slidably attached or fixed to the cutting wires. As the device is pulled back and forth (i.e., reciprocated) across the tissue, the cutting wires **2404** will begin to cut through bone and/or soft tissue. In some embodiments, the device is pulled “up” (top side of the device toward the back of the patient) and against the tissue while the device is reciprocated across the tissue. Due to this upward pressure, the cutting wires will begin to cut into the tissue and create troughs into the tissue. As the cutting wires cut tissue, they will also cut through the breakaway elements **2415**, such that the spacer is released from the breakaway elements.

In an alternative variation, as shown in FIG. **25**, the spacer **2501** may include only a single flexible portion **2502**. In this variation, the spacer may be coupled to the cutting wires **2504** at a first end **2508** while the flexible portion is coupled to the cutting wires **2504** at a second end **2509**. As shown, the spacer **2501** is preferably rigid in a first plane (across the width of the device, i.e. into the page) such that it will prevent approximation of the cutting wires. The spacer may be flexible in a second plane (along the length of the device) and/or in a third plane (across the thickness of the device, i.e. up and down with respect to the figure).

In another alternative embodiment, the rigid or semi-rigid spacer **2601**, as shown in FIGS. **26A-26C** is removably coupled to the cutting wires **2604**. As shown in cross sectional view in FIG. **26A**, as the cutting wires **2604** cut deeper into bone **2605** (or other tissue), the tissue **2605** prevents the spacer from entering into troughs **2606** formed by the cutting wires **2604**. The spacer therefore “pops” off of and away from the cutting wires **2604** that are within the tissue **2605**. As shown in FIG. **26A**, the spacer **2601** remains exterior to the target tissue as the cutting wires **2604** cut deeper into the target tissue. In some variations, the cutting wires **2604** may be able to slide within the troughs **2612** of the spacer. In this variation, the spacer may be static (i.e. not reciprocating) while the wires are reciprocated. The material of the spacer may be a molded polymer, or alternatively an extruded polymer. The elastic nature of the material would facilitate both loading and release of the cutting wires.

In yet another alternative variation, as shown in cross section in FIG. **27A**, rather than “popping” off of the cutting wires **2704**, the spacer **2701** is configured to slide off of the cutting wires. In some variations, the spacer may not be removed completely from the tissue modification device, but may be removed from a portion of the cutting wires to allow at least a portion of cutting wires **2704** to cut into and/or through tissue. In some embodiments, the spacer may bunch and fold up along the cutting wires rather than sliding completely away. As shown in FIG. **27A**, the spacer may further include coupling elements **2710** that are configured to removably couple the spacer to the cutting wires **2704**. Coupling element **2710** may be crimped, welded or coupled to the cutting wire in any suitable fashion. In some variations, the cutting wires may be replaced by non cutting cables and the coupling elements **2710** may include cutting edges (not shown).

FIG. **27B** illustrates (in cross section) an alternative embodiment of a spacer **2705**. For example, as shown in FIG. **27B**, the spacer may include cutting ridges **2707**. These cutting ridges may extend such that they have a height that is greater than the diameter of the cutting wires **2706**. The cutting ridges may function to hold the cutting wires a distance apart from one another and prevent the cutting wires **2706** from approximating. The spacer is configured to maintain the distance between the cutting wires while the wires are

26

positioned within the patient and during the initial reciprocations of the tissue modification device against the tissue. As the device is pulled back and forth (i.e. reciprocated) across the tissue, the cutting ridges will begin to cut through the bone and/or soft tissue. In some embodiments, the device is pulled “up” (toward the back of the patient) and against the tissue while the device is reciprocated across the tissue. Due to this upward pressure, the cutting ridges will begin to cut into the tissue and create troughs into the tissue. The cutting ridges may be positioned at discrete locations along the length of the device. Therefore, as the initial troughs are formed, eventually, the cutting wires may fall into the troughs and continue cutting deeper troughs as the spacer moved away from the cutting wires.

In any of the variations described above, the spacer may additionally be configured to function as a shield that functions to prevent non-target tissue such as nerves or arteries from damage while the tissue modification device is used to cut and/or modify tissue within a patient. In some embodiments, the spacer and/or shield may include electrodes and may be configured to detect neural structures as described in conjunction with FIG. **1C**. Alternatively or additionally, the spacer and/or shield may be configured to deliver drugs, haemostatic agents, or other suitable agents. In some embodiments, the spacer and/or shield may be tapered. For example, the distal end may be narrower than the proximal end such that the user may pull the device into position. The tapered nature of the spacer ensures that the surgeon can pull the device in as far as is desired before beginning reciprocation, thereby optimally separating the wires before pulling them into the tissue. For example, to perform a pedicle to pedicle Facetectomy, the user may pull the device in until each side of the device is against a pedicle.

In some embodiments, the device may be configured to aid in the releasing of adhesions. For example, the facet capsule or bone may be adherent to dura, neural or vascular elements in the foramen. To facilitate the surgeons’ or users’ ability to release these potential adhesions and ensure that the facet is free from these vulnerable tissues, one of the following devices described may be helpful.

In some embodiments, the spacer is a slider element **2801** as shown in FIG. **28**. Slider element **2801** is coupled to cable **2811** which may be coupled to an actuator (not shown) located on the proximal portion **2812** of the device, in some instances, at or near a proximal handle. As the tissue modification device **2800** is inserted into and positioned within a patient, slider is positioned toward the center of the tissue modification portion of the device, e.g. toward the center of the cutting wires **2804**. As shown, the slider is positioned a distance A from the distal end of the cutting wires and a distance B from the proximal end of the cutting wires. A user may position the distal portion (distance A) around the target tissue. Slider **2801** may limit the initial stroke length of the reciprocations to substantially the length A. A shorter stroke length may provide greater control and/or less of a propensity for the wires to approximate during reciprocation. Once a user has initiated cutting with the cutting wires **2804** and/or once the cutting wires have formed initial troughs in the target tissue, the slider may be slid proximally to increase the stroke length from length A to a length equal to or less B.

As shown in FIG. **29**, in an alternative variation, the slider **2901** may have a pronged configuration. The slider in this configuration is rigid, at least across the width of the device, to prevent the wires **2904** from approximating during reciprocation. The slider may be pronged such that the pronged

portions may be inserted into the troughs created by the cutting wires. As described above, the slider may be coupled to an actuator.

FIG. 30A illustrates a cross-section through one variation of a facet-joint modifying device that includes two bone-sawing elements **3002**, **3002'**. The two saw elements (which may be cables or surfaces including blades) may be separated by a spacer **3005**. FIG. 30C shows a top view of one variation of a facet joint modifying device configured to perform a facetectomy. The distal end of the device is configured to couple with the pull wire, as described above. The tissue-contacting portion of the device may include two parallel cutting surfaces (which may be cables) **3002**, **3002'** that are separated from each other. These two separate cutting surfaces may allow two cuts to be made through the facet joint simultaneously, permitting removal of a portion of the facet joint. This version of the facet-joint modifying device may also include one or more spacers **3005**. Spacers may prevent the cutting surfaces from spreading or contracting towards each other, particularly if the cutting surfaces are cables. In some variations these spacers may be removable or separating, so that as the facet joint modifying device cuts the facet joint, pressure applied as that device is reciprocated against the bone may cause separation, breaking, or removal of the spacer. FIG. 30B illustrates a cross-section through one portion of the device having a breakable (e.g., frangible) spacer **3005**.

Tissue Modification Device Having Single Tissue-Modifying Surface

Other facet joint modifying devices (including those shown in FIGS. 31A-31E) may include a single tissue-modifying surface, and thus does not need a spacer. In one variation of a method for performing a facetectomy, a cannulated probe for guiding a guidewire/pull wire is first inserted in and/or around the joint. FIG. 32A illustrates a facet joint **3205** including the superior articulating process (SAP) and inferior articulating process (IAP) between the lower **3209** and upper **3207** vertebra. A guidewire/pull wire may be threaded through, around, or adjacent to the facet joint as indicated generally by the line **3203**. In some variations, the pathway through the facet joint passes over the top of the superior articulating process (SAP). In some variations, the pathway through the facet joint passes under the SAP giving access to the tip of the SAP. Placement of the guidewire around or through the facet joint may be aided by distraction of the spinous process. Thus, in some variations, the spinous process may be distracted before performing the procedure.

Once the probe has been used to position the guidewire, it may be removed. As illustrated above, the probe may include one or a plurality of (concentric) cannula including cannulas having different curvatures so that the guidewire may be directed around the joint and pointed toward the appropriate exit site. The guidewire or pull wire may then be pushed through the cannula and out of the patient. A distal handle may then be attached to the distal end of the guidewire to aid in manipulating the guidewire/pull wire from the distal end.

Next, a treatment device may be pulled into position in or around the joint by coupling the distal end (or end region) of the joint treatment device to the proximal end of the guidewire/pull wire. In some variations the treatment device includes one or more surfaces that are configured to abrade, scratch or otherwise remove bone to perform a facetectomy. For example, FIGS. 31A-31E illustrate variations of a treatment device. In FIG. 31A, the treatment device includes a front and a back articulating surface that can be drawn across the joint surfaces to roughen them and/or remove bone from the joint. In this example, the distal end of the device includes

an attachment/connector site for the guidewire. The proximal end also includes an elongate member and may have a proximal handle. In some variations the roughening surface is expandable, so that it may be pulled into the joint in a collapsed or condensed form (protecting non-target tissue), and once in the joint it can be expanded to the treatment form. For example, the device may be inflatable; inflation may expand the device so that the contact surface(s) can push against the joint surface(s). Once in position, the device can be moved bimanually within or around the joint to scrape or otherwise modify the joint to remove bone, by pulling distally and proximally (e.g., back and forth).

FIGS. 31B-31D illustrate alternative cross-sections for the joint treatment devices described. For example, in FIG. 31B, the device is substantially flat, having an upper and lower surface. As mentioned, this device may be inflatable/expandable to increase (or decrease) the spacing between the upper and lower surfaces, or to "stiffen" the implant once it is expanded. FIG. 31C shows a device having an oval cross-section, and FIG. 31D shows a device having a round cross-section. In all of these variations the devices include 'teeth' or protrusions that are configured to remove or modify bone or other tissue. In some variations the devices are configured to abrade, cut, and/or remove cartilage in the joint. In some variations the device is configured to abrade cartilage without substantially cutting or removing bone. In some variations the device surface is configured to abrade cut and/or remove bone from the joint and or remove the joint all together.

The device may be actuated by moving it backwards and forwards (proximally and distally), by bimanual reciprocation. In some variations, such as that shown in FIG. 31E, for example, the device may also or alternatively be articulated by rotating it axially once it is in position in the joint or around the joint.

Expandable Tissue Modification Devices and Methods

Some variations of the tissue modification devices described herein include an elongate, flexible element having a first width and a second width and a tissue modification element coupled to the flexible element. The flexible element may include an expanding mechanism that expands at least a portion of the flexible element from the first width to the second width. Each of these features is described and illustrated in greater detail below.

As shown in FIG. 33, in some embodiments, the tissue modification device includes an elongate, flexible element **3301** having a first width (not shown) and a second width (shown). The flexible element has an axial length, a width (first and second) and a thickness. As shown, the axial length is greater than the width, and the width is greater than the thickness. In some embodiments, the first width may be substantially equal to or less than the thickness and the second width may be greater than the thickness. The first width is generally smaller than the second width. The flexible element is preferably sized and configured such that it may be inserted into a patient in the first width, and then expanded to the second width in order to modify target tissue. For example, the flexible element may be expanded to the second width in order to wrap around a facet joint such that element **3302** is on a first side of a facet joint (such as the superior articular process (SAP)) and element **3303** is on a second side of the facet joint (such as the inferior articular process (IAP)) In some variations, the device will modify or remove a width of target tissue that is substantially equal to or greater than the second width of the flexible element. In one specific example, the first width may be 2-15 mm such that the device may fit within an interlaminar window of a patient's spine. The second width may be 5-20 mm such that the device may modify

a width of tissue that is 5-20 mm wide such as the facet joint of a patient's spine. In some variations, the second width of the device may range from 8 to 15 mm such that the user may then insert an inter body device, such as a cage, through the opening created to the space between adjacent vertebral bodies. The flexible element may be adjustable to a plurality of second widths. For example, the flexible element may be inserted into a patient at a first width and then advanced such that it is adjacent to a target tissue, around a facet joint for example. The flexible element may then be expanded until it contacts an adjacent pedicle or other suitable anatomy and can no longer expand.

The flexible element **3301** may include two flexible elongate cables **3302** and **3303** that are expandable from the first width to the second width. The wires may be configured such that for the first width of the flexible element, the wires are adjacent to one another and/or substantially touching along their length. The wires may then be separated from one another, as shown in FIG. **33**, such that the flexible element has a second width. The cables may extend substantially adjacent to each other from the proximal end of the device to the distal end of the device. At least a portion of the cable is flexible. Any appropriate cable may be used, including metal or polymeric cables. Cables may be single-filament or formed of multiple filaments. The portion of the cable towards the distal end of the device, as shown in this example, may be hinged or otherwise coupled to a coupling element **3304**. Coupling element **3304** may be configured to receive an end of a guidewire or pull wire, such that flexible element may be pulled and/or positioned by the pull wire.

In FIG. **33**, the flexible element **3301** of the device is joined to the proximal end of the device **3305**, which may be less flexible, and may include a handle or an attachment region for a handle. This interface between the flexible cables and the proximal end and/or handle may be a joint or hinge, or any other suitable coupling mechanism. The proximal joint near the proximal end may be a ball joint, in some embodiments, which allows the rotation of the handle and/or proximal portion of the device with respect to the tissue modification region and/or flexible element of the device. Thus, the proximal handle may be rotated along the long axis of the tissue modification device, but will not substantially torque the tissue modification region of the device. The variation shown in FIG. **33** may also include a proximal connecting region near the proximal end **3305** of the device to which a handle is attached. This connecting region may be relatively stiff (or inflexible), or it may also be flexible.

In some embodiments, as described below, the flexible element may comprise a balloon or other suitable flexible element. In some embodiments, as shown in FIG. **34**, the flexible element may comprise a loop of cable, rather than two separate cables. Cable loop **3401** may be expandable from the first width to the second width. The cable loop may be configured such that for the first width of the flexible element, two side portions of the loop are adjacent to one another and/or substantially touching along their length. The two side portions of the loop may then be separated from one another, as shown in FIG. **34**, such that the flexible element has a second width. The device may further include a pulley **3402** or other suitable gear or wheel, as shown in FIG. **34**, about which the cable loop may be wound. The pulley may function to expand the cable loop from the first width to the second width, and or may function to aid in the reciprocation of the cable loop for cutting tissue as described below.

The tissue modification device includes a tissue modification element coupled to the flexible element. In a first embodiment, the flexible element includes at least one wire that is

configured to cut tissue or otherwise modify tissue. The wire may be textured or coated such that it is adapted to cut tissue. As shown in FIG. **33**, the device further includes at least one cutting edge **3306** coupled to at least a portion of the flexible element **3301**. In some embodiments, the cutting edge is crimped onto the cable. The tissue modification device may include cutting edges directly coupled to a cable, it may include ferrules or beads threaded onto the cables onto which a cutting edge is fixed or integrated, or the device may include any other suitable cutting edges coupled to the flexible element in any suitable fashion. The flexible element may include cutting elements such as beads, blades, wires, or other suitable cutting elements. As shown in FIG. **33**, a portion of the device may include cutting cables, while a portion of the device includes rungs threaded onto cables (with or without cutting edges on the rungs). The tissue modification device may modify or cut tissue by moving the modification elements against the target tissue. In some variations, the device is reciprocated against the target tissue. In an alternative embodiment, a first cable of the flexible element is moved against the target tissue in a first direction, and a second cable is moved against the target tissue in a second direction, and then each cable is reciprocated against the target tissue. Alternatively, in the case of the flexible element comprising a loop of cable, the loop may rotate or be driven against the target tissue, as shown in FIG. **34**.

In an alternative embodiment, the tissue modification element may modify tissue using an energy such as heat or radio frequency energy. The energy may function to desiccate and/or shrink the tissue. Alternatively, the energy may function to cut the tissue. As shown in FIG. **35**, the flexible element may further include a cutting loop **3500** that functions to cut, desiccate, and/or shrink the target tissue. In some embodiments, the flexible element is coupled to a heating element or other energy source.

In some embodiments, the tissue modification device includes an expanding mechanism that expands at least a portion of the flexible element from the first width to the second width. In a first embodiment, as shown in FIG. **36**, the flexible element comprises two wires **3601** and **3602** expandable from a first width (A) to a second width (B). In some embodiments, the expanding mechanism further functions to hold the flexible elements in position, i.e. hold them a distance apart (the second width) and prevent them from approximating, particularly while modifying tissue with the device.

In a first variation, as shown in FIG. **36**, the expanding mechanism **3603** is coupled between the two wires **3601** and **3602** and separates the wires from a first width to a second width as the expanding mechanism is moved along the length of the wires. The expanding mechanism may be triangular shaped or otherwise configured to function in a manner similar to a zipper or ZIP-LOCK bag sliding mechanism. Alternatively, as shown in FIG. **37**, the expanding element may be an expander rod **3703**. The rod may be inserted between the two wires or cables once the wires are in place (i.e. inserted into a patient and/or adjacent to target tissue), and may be sized and configured to expand the flexible element from a first width (A) to a second width (B).

In an alternative embodiment, as shown in FIG. **38**, the expanding mechanism comprises a first element **3801** coupled to two wires **3802** and **3803** at a first location and a second element **3804** coupled to the two wires at a second, distal location. The device may be inserted into a patient while the wires are a first width apart, and then by moving the

first element **3801** toward the second element **3804**, as shown in FIG. **38**, the wires expand from a first width to a second width.

As shown in FIGS. **39** and **40**, the expanding mechanism may comprise a frame **3900**, expandable from a first width (not shown) to a second width. The frame may be a shape memory material such as Nitinol or any other shape memory, shape changing, or super elastic material. The frame may comprise at least two frame portions (such as wires **3901** and **3902**) that are expandable from a first width to a second width. In a first embodiment, as shown in FIG. **39**, the frame may further include a mesh **3903** or other material coupled to the frame between the frame portions. The mesh may function to capture and/or remove cut or modified target tissue, such as a facet joint. In some embodiments, the frame may not completely encircle the mesh material, for example, the frame may comprise a distal end and a proximal end, each with an expandable fork structure.

As shown in FIG. **40**, the frame may further include a sleeve **4001** coupled to the frame **4000**. The sleeve may have a width substantially equal to the first width of the flexible element, such that the frame may be inserted into the sleeve and held at a first width. The sleeve may then be pulled back (shown in FIG. **40** in the pulled back position) to allow the frame to separate. When removing the device after modifying tissue, the frame in some embodiments, may be configured to grab the modified target tissue **4002** as the frame retracts (shown by arrows **4003**) and pull the tissue back with the frame into the sleeve **4001** for easy removal of the tissue.

As shown in FIGS. **41A** and **41B**, in some embodiments, the expanding mechanism is a balloon **4100**. The device in this configuration may have cutting blades **4101** coupled to the side portions of the balloon such that the blades may cut a width of tissue substantially equal to the width of the balloon in its inflated or expanded configuration. In this embodiment, the balloon may further include hook **4102** configured to capture soft tissue, such as ligament, for example.

As shown in FIGS. **41C** and **41D**, the expanding mechanism may be actuator **4103** (FIG. **41B**) or actuator **4104** (FIG. **41C**). In a first variation, as shown in FIG. **41C**, the actuator **4103** is a spring or piston that expands and contracts to move the flexible element **4105** from a first width to a second width (shown). In a second variation, as shown in FIG. **41D**, the actuator is wire **4104** made from a shape memory material such as Nitinol or any other shape memory, shape changing, or super elastic material. The wire may be coupled to the flexible element **4105** as shown and is expandable such that it moves the flexible element from a first width to a second width (shown).

As shown in FIG. **42**, the device may include a shield **4200** coupled to the flexible element. The shield may be coupled to the flexible element **4201** such that while the flexible element is adjacent to the target tissue, the shield protects the adjacent non-target tissue, such as neural tissue, and/or may collect the tissue cut and/or modified by the device. In some embodiments, the flexible element functions to slide distally and proximally within or over a substantially stationary shield. In some embodiments, the shield may function to contact and/or engage with and remove tissue (for example, a facet joint) cut and/or modified by the device. In some embodiments, as shown in FIG. **42**, the flexible element comprises two wires **4202** and **4203** coupled to a shield and held a distance apart from one another. The shield is coupled adjacent to the bottom surface of the flexible element and is sized and configured to maintain the width of the flexible element by preventing the cables from approximating toward one another while modifying tissue.

In some embodiments, the device may include a tracking element. For example, a tracking element may be disposed in the distal end of the device, such that the tip of the device may be tracked as it is inserted into a patient and/or moved within the patient. Alternatively, the device may include multiple tracking elements disposed along the length of the device, or multiple tracking elements disposed along a portion of the length of the device (for example along the cutting region of the device). In some embodiments, the tracking element is a material that is detectable by an imaging system. Some examples of suitable tracking elements include echogenic materials or substances (i.e. configured to form an echogenic surface) detectable by an ultrasound system, and radio-opaque materials detectable by a radiograph system, such as a fluoroscope. Alternatively, the tracking element may be configured to be detectable by an MRI or Infrared system. In some embodiments the tracking element is preferably a coil configured to be detected by an electromagnetic tracking or navigation system. For example, the devices described herein may incorporate a tracking system such as the AXIEM™ Electromagnetic Tracking Technology, e.g., the StealthStation® AXIEM™ (Medtronic Navigation, Louisville, Colo. USA). In some embodiments, the device is configured to generate an electromagnetic field around a patient's target anatomy that can be tracked to triangulate the positioning of devices having tracking elements.

As mentioned above, any of the devices described herein may include a guidewire coupler. A guidewire coupler is configured to attach to a guidewire (e.g., one end of a guidewire) so that the device can be manipulated, at least in part, by pulling on the guidewire after the guidewire has been secured to the device. For example, in some variations a guidewire may be inserted into the body from a first location outside of the body, then passed around the target tissue (e.g., around a spinal foramen) and out of the body from a second position. The distal end of the guidewire may then be coupled to the tissue modification device (such as the one shown in FIG. **33**) and pulled through the body until the tissue modifying region of the device, e.g., the portion of the device including tissue modification elements **3306**, is positioned opposite the target tissue. In some variations the guidewire used includes a tip region that is enlarged and may engage the guidewire coupler. For example, the guidewire may have a proximal end with a flange or ball. This enlarged region may be configured to fit into an opening on the guidewire coupler so that the guidewire can be pulled distally from outside of the patient. In some variations the distal end of the device may be completely withdrawn, so that it can be grasped and manipulated. In other variations, the distal end of the tissue-modification device remains coupled to the guidewire, and the guidewire may be grasped to manipulate the distal end of the tissue-modification device. A handle may be attached to the guidewire. As mentioned, in operation, the device is urged against the target tissue and may be moved in the proximal/distal direction to modify (e.g., cut) the target tissue. For example, both the proximal and distal ends of the tissue-modification device may be pulled to urge the device against the target tissue, and may each be alternately pulled to a greater degree than the other handle to slide the device over the target tissue, allowing the cutting edges to cut and modify the target tissue.

For example, a guidewire coupler may include an opening and/or channel to receive an enlarged or necked region at the proximal end of the guidewire. This configuration may be similar to the "trailer hitch" configuration described in many of the references previously incorporated by reference.

The methods for modifying tissue described herein typically include one or more of the following steps: inserting an elongate, flexible element having a first width; advancing the flexible element until a portion of the flexible element is adjacent to a target tissue; expanding at least the portion the flexible element adjacent to the target tissue to a second width; and modifying the target tissue with the flexible element. A method for modifying tissue may include one or more of these steps in any combination. Each of these steps is described and illustrated in greater detail below.

The inserting functions to bring the device into position. The inserting step may further include inserting the device into a patient, and more specifically into the spine of a patient, for example. In some variations, the device may be inserted through an interlaminar window of a patient's spine. In this variation, the flexible element is preferably configured in the first width. The first width may be equal to or smaller than the space defined by two adjacent lamina (i.e. the interlaminar window). Once inserted, the device may be advanced into position. The device may be moved until it is adjacent to the target tissue. In some embodiments, the advancing step further includes the steps of passing a guidewire at least partially around the target tissue and pulling the device around the target tissue using the guidewire, such that the flexible elements and/or cutting element are adjacent to the target tissue. In some embodiments, the guidewire is coupled to the guidewire coupler at the distal portion of the device. The inserting and advancing steps may be performed while the flexible element is configured in the first width. This allows the device to be smaller and more maneuverable such that it may fit through and around tight anatomical spaces and locations.

Once the device is positioned correctly within the patient, it may be desirable to expand the flexible element from the first width to the second width. The expanded width (second width) is wider than the first width, and allows the cutting elements coupled to the flexible element to modify a wider and/or larger portion or area of target tissue. In some embodiments, the second width may be substantially equal to (or slightly smaller than) the width of a facet joint, the width of the neural foramen of a patient's spine, and/or the width of an interbody fusion device. In some embodiments, the second width may be substantially equal to (or slightly smaller than) the distance from a first pedicle to an adjacent pedicle. Once the device is expanded, the wider device may be used to modify target tissue.

In some embodiments, the modifying step further includes moving the flexible element across the target tissue. The flexible element may be moved through or over the target tissue. The flexible element may also be reciprocated or moved back and forth across the target tissue in order to modify an area of target tissue. The modification elements may be reciprocated between a distal position and a proximal position. The device may be reciprocated by applying tension to both the proximal end and the distal end of the device to drive the flexible element and/or tissue modification elements against the target tissue.

In some embodiments, modifying target tissue may include cutting a width of tissue, such as a facet joint, having a width substantially equal to the second width of the flexible element. As shown in FIG. 43, methods for modifying tissue described may alternatively include one or more of the following steps: inserting a first elongate, flexible element **4300** into the patient at a first location; advancing the first flexible element until a portion of the flexible element is adjacent to a target tissue; inserting a second elongate, flexible element **4301** into the patient at the first location, a distance from the

first flexible element; and modifying the target tissue with the flexible elements. A method for modifying tissue may include one or more of these steps in any combination. Each of these steps is described and illustrated in greater detail below.

In some embodiments, the inserting a second flexible element step further includes inserting a second flexible element a distance from the first flexible element, wherein the distance is substantially equal to the width of the facet joint. Alternatively, the inserting a second flexible element step may further include inserting a second flexible element a distance from the first flexible element, wherein the distance is substantially equal to the width of an interbody fusion device. Once inserted, the two flexible elements may be coupled to a distal handle **4302** and/or a proximal handle **4303**. The method may further include the steps of coupling the distal end of the first flexible element to a distal handle and then coupling the distal end of the second flexible element to the distal handle.

These steps have the benefit in that the single flexible element may be inserted and easily maneuvered independently through tight anatomical sites and locations. By then inserting a second flexible element (which is also easily maneuvered independently) at an angle to or a distance from the first flexible element such that the tissue modification portions of the flexible elements are adjacent to one another and a distance apart (e.g. a distance substantially equal to the width of the facet joint or the width of an interbody fusion device) and may modify a portion of tissue substantially equal to that distance. In some embodiments, the two flexible elements function to cut a strip of target tissue having a width substantially equal to the distance between the flexible elements.

Delivery Devices and Methods

FIG. 44 illustrates an embodiment of a delivery device for delivering a tissue modification device for removing tissue from a patient. In some embodiments, the device includes a ribbon shaped flexible elongate body **4401** having a width defined by a first edge **4402** and a second edge **4403**. In some embodiments, the first and second edges are substantially parallel. The device may also include a first channel disposed along a portion of the length of the elongate body, positioned toward the first edge of the elongate body, and a second channel disposed along a portion of the length of the elongate body, positioned toward the second edge of the elongate body. As shown, the channels may be made up of elements **4404** and **4405**. Alternatively, the channels made comprise a single tubular element (not shown). The channel is sized and configured to receive two elongate cutting members **4406**. In some embodiments, the device may also include a guidewire coupler (not shown) at the distal end region of the elongate body **4401**.

Also described herein are methods for delivering tissue modification devices for removing tissue from a patient. In some embodiments, the methods include the steps of inserting an elongate, flexible shield **4401** into the patient at a first location; advancing the shield until a portion of the shield is adjacent to a target tissue; inserting a first elongate, flexible cutting element **4406** through the shield until a portion of the first cutting element is adjacent to a target tissue; inserting a second elongate, flexible cutting element **4406** through the shield, a distance from the first cutting element and substantially parallel to the first cutting element, until a portion of the second cutting element is adjacent to a target tissue; and modifying the tissue with the flexible elements.

In some embodiments, the methods include the steps of inserting a first elongate, flexible cutting element **4406** until a portion of the first cutting element is adjacent to a target tissue; advancing an elongate, flexible shield **4401** into the

patient, wherein a portion of the shield is advanced over the first elongate, flexible cutting element; inserting a second elongate, flexible cutting element **4406** through the shield, a distance from the first cutting element and substantially parallel to the first cutting element, until a portion of the second cutting element is adjacent to a target tissue; and modifying the tissue with the flexible elements. In some embodiments, the methods further include the step of removing the shield **4401** from the patient while leaving the cutting elements in position within the patient.

Tissue Modification Device Having at Least One Elongate Cutting Member

Described herein are devices, systems and methods for cutting spinal tissue such as bone and/or soft tissue, and particularly spinal bone in the dorsal column using a flexible cutting element that may be passed around the bone. In some embodiments, these devices, methods and systems may be used to cut a single cut into tissue. The device may include a spacer to aid in positioning the single cutting element within the spine. For example, the device may be positioned through a neural foramen and around a facet joint. The spacer may be positioned within the foramen while one of the outer edges may be positioned against the caudal pedicle. The cutting member may be held at the opposite outer edge of the spacer and therefore may be positioned to cut into the Superior Articular Process (or more specifically the cephalad tip of the SAP) of the facet joint. In some alternative methods, the outer edge of the spacer may be positioned at the cephalad pedicle and the cutting member may be positioned caudal from there. The methods, devices and systems described herein may be used as part of a spinal surgical procedure involving a complete or partial removal of spinal bone or joint, such as a decompression, a laminectomy, laminotomy, facetectomy, pediclectomy, etc.

FIGS. **45A** and **45B** illustrate an alternative embodiment of a tissue modification device having a pair of flexible elongate cables, one being a cutting member **4502** and one being a non cutting cable **4501**, and a spacer **4500**. As shown in FIG. **45A**, the tissue modification device includes a distal end having a tissue modification region and a proximal end having, in some embodiments, a proximal handle. The distal tissue modification region includes the pair of flexible elongate cables and the spacer. As shown, a guidewire coupler **4504** may be at the distal end of the tissue modification device. The guidewire coupler may be configured to attach to a guidewire (e.g., the proximal end of a guidewire) so that the device can be manipulated (e.g. reciprocated), at least in part, by pulling on the guidewire after the guidewire has been secured to the device. As shown in FIG. **45A**, the spacer (or substrate) may further include a passive restraint **4505** coupled to one of the outer edges of the spacer. As shown, portions of this restraint are coupled to the cutting member. These restraints may function to hold the cutting wire toward the outer edge of the device and/or prevent the cables from approximating. In some embodiments, the non-cutting cable may be fixed to the substrate or may be held in position with a restraint. The restraint on the non-cutting cable may not release the cable such that the cable will remain with the substrate and will not cut and move through tissue as the cutting member will.

As shown, the restraints may not run the entire length of the tissue modification region of the device. This may be desirable such that a portion of the cutting wire is exposed. These exposed wire portion(s) may provide cutting action during the initial reciprocations of the tissue modification device against the tissue. As the device is pulled back and forth (i.e. reciprocated) across the tissue, the exposed portions of the cutting wire will begin to cut through the bone and/or soft tissue. In

some embodiments, the device is pulled “up” (toward the back of the patient) and against the tissue while the device is reciprocated across the tissue. Due to this upward pressure, the cutting wire will begin to cut into the tissue and create a trough into the tissue. As the initial trough is formed in the tissue, and the cutting wire moves deeper into the tissue, the cutting wire will eventually detach from the restraint. In some embodiments, the restraint is made from an elastic or otherwise deformable material such that the upper lip of the restraint can deform to allow the cutting wire to pull out of the restraint. Alternatively, the cutting wire may cut through or break off a portion (e.g., the upper lip) of the restraint.

In some embodiments, a right sided and a left sided device may be made having the cutting member on the right and left sides of the device respectively. Alternatively, the cutting member may be positioned along the center portion of the device such that a single device may be used on both sides of the spine.

As shown in FIG. **45B**, the tissue modification device further includes a spring **4503**. This spring may function to couple the substrate and the non-cutting cable to the proximal end of the tissue modification device. In some embodiments, the non-cutting cable may be coupled to the spacer and not coupled to the spring. As the cutting wire cuts into the tissue, as shown in FIGS. **46A-46C**, and the non-cutting cable and the spacer moves away from the cutting wire, the spring will stretch and allow the proximal end of the non-cutting cable and the spacer to move toward the distal end of the device such that the distal end of the spacer and non-cutting cable may bend and move away from the cutting wires. In some alternative embodiments, the tissue modification device may include a single cutting member while not including a non-cutting cable.

The cutting member may cut through a portion of a Superior Articular Process (SAP) of the facet joint. In some embodiments, it may be desirable to not cut all the way through the SAP and in this case, it may be necessary to use a tool to push the cutting member back out of the SAP. In some embodiments, an additional tool (such as a Rongeur) may be used to break the remaining portion of the SAP and/or to remove the cut portion of the SAP from the remainder of the SAP. In some embodiments, once the SAP (or a portion thereof) is removed, a flexible tissue modification device, such as a shaver device, may be positioned within the foramen of the spine and reciprocated against the target tissue to perform a decompression.

Tissue Modification Device Having a Plurality Elongate Cutting Members

In some alternative embodiments, the single cut may be accomplished with a device having a single cutting member and no spacer. As shown in FIG. **47**, the device may include multiple cutting wires **4702**. As shown, the wires may be arranged in a side by side configuration. This device may cut a trough into the tissue having a width equal to the width of the multiple cutting wires. This may be beneficial in that the width of the guidewire coupler **4704** may be less than the wide of the multiple cutting wires. Therefore, once the wires have cut into the tissue, the device may be unhooked and pulled back through the wider trough in the tissue. In an alternative variation, the device may include a single wire having a width greater than the guidewire coupler. In some embodiments, the device may include abrasion elements on the spacer to help hold the position on the spacer with respect to the bone while the cutting member initiates the trough. For example, the spacer may include blades or other abrasive particles that will dig into or catch onto the bone such that the cutting member will not slide off of the SAP for example.

Alternatively, the non-cutting cable may include some abrasive or cutting elements such that it can catch onto bone to hold the device in place while the cutting member initiates the trough in the tissue.

Various embodiments of tissue modification devices and systems, as well as methods for making and using tissue modification devices and systems, are provided herein. In general, a flexible tissue-modification device as described herein is configured to remove tissue from a patient. In particular, these tissue-modification devices may be configured to decompress spinal stenosis. These devices typically include a flexible elongate body that extends proximally to distally (proximal/distal), and is configured to be inserted into a patient so that it extends around the target tissue, so that it can be bimanually pulled against the target tissue by applying tension to either end of the device. Thus, the device may be extended into, through, and/or around a spinal foramen. The device is flexible in at least one plane. For example, in variations in which the device has an elongated ribbon shape that is long and flat with a width greater than the thickness, the device includes a first major surface (e.g., a front) and a second major surface (a back), and has edges (minor surfaces) between the first and second major surfaces. The first major surface may be referred to as the anterior or front surface and the second major surface may be referred to as the posterior or back surface. The devices described herein may be flexible along the anterior and posterior surfaces, and the anterior or front surface may include one or more cutting edges configured to cut tissue as the anterior surface of the device is urged against a tissue. The posterior surface may be configured to shield or protect non-target tissue.

Although much of the following description and accompanying figures generally focuses on surgical procedures in spine, in alternative embodiments, devices, systems and methods of the present invention may be used in any of a number of other anatomical locations in a patient's body. For example, in some embodiments, the flexible tissue modification devices of the present invention may be used in minimally invasive procedures in the shoulder, elbow, wrist, hand, hip, knee, foot, ankle, other joints, or other anatomical locations in the body. Similarly, although some embodiments may be used to remove or otherwise modify ligamentum flavum and/or bone in a spine to treat spinal stenosis, in alternative embodiments, other tissues may be modified to treat any of a number of other conditions. For example, in various embodiments, treated tissues may include but are not limited to ligament, tendon, bone, tumor, cyst, cartilage, scar, osteophyte, inflammatory tissue and the like. Non-target tissues may include neural tissue and/or neurovascular tissue in some embodiments or any of a number of other tissues and/or structures in other embodiments. In one alternative embodiment, for example, a flexible tissue modification device may be used to incise a transverse carpal ligament in a wrist while inhibiting damage to the median nerve, to perform a minimally invasive carpal tunnel release procedure. Thus, various embodiments described herein may be used to modify any of a number of different tissues, in any of a number of anatomical locations in the body, to treat any of a number of different conditions.

In some embodiments, as shown in FIGS. 48-51C, a flexible tissue-modification device as described herein includes a flexible elongate body having a tissue modification region and a guidewire coupler at the distal end region of the elongate body. As shown, the tissue modification region may include a plurality of parallel cutting wires distributed across the tissue modification region. In some embodiments, a flexible tissue-modification device as described herein includes a

flexible elongate cable that extends from the proximal end of the device to the distal end of the device and back toward the proximal end of the device, and as shown, there may be at least one cutting edge on at least two parallel portions of the cable—to make up the tissue modification region. Furthermore, the tissue modification device of this embodiment may include a rung that extends across at least two parallel portions of the cable.

As shown in FIG. 48, a tissue modification device as described herein may include a flexible elongate body 200 having a tissue modification region 201 and a guidewire coupler 202 at the distal end region of the elongate body. As shown, the tissue modification region may include a plurality of parallel cutting wires 203 distributed across the tissue modification region. In this embodiment, the cutting wires 203 run proximally and distally along the length of the tissue modification region 201. The cutting wires are arranged such that they are coupled to the device in a side by side configuration across the width of the elongate body. In an alternative embodiment, not shown, the cutting wires may be arranged such that they are in a side by side configuration along the length of the tissue modification region and such that the wires run perpendicularly to the length of the elongate body. The cutting wires may be configured in any other suitable arrangement such that they form a substantially ribbon shaped tissue modification region. A ribbon shape may be defined in some instances as having a length that is greater than the width, while the width is greater than the thickness.

As shown in FIG. 49, the tissue modification device includes a cutting wire 303 that is folded into a serpentine configuration such that it runs back and forth across the tissue modification region 301 of the device. In some embodiments, the tissue modification device may include two or more cutting wires that are each folded into a serpentine configuration such that they each run back and forth across the tissue modification region of the device. In this embodiment, a first folded cutting wire may be positioned in a side by side configuration to an adjacent folded cutting wire. As shown, the tissue modification region is made up by multiple portions of the cutting wire that are arranged parallel to one another in a side by side configuration. The wire may be configured such that each parallel portion of the wire is positioned at a distance from the adjacent portion of wire. This may allow cut tissue to pass through between the wire portions of the device. As shown, the cutting wire may be thread through a rung or rungs 304 as described in greater detail below. In some embodiments, the cutting wire may function to connect the rungs and other portions of the tissue modification device together. Alternatively, as described in greater detail below, the device may include a separate connector, such as a cable, to connect the rungs and other elements of the device. In some embodiments, the cutting wire may include cutting edges 305 along the entire length of the cutting wire. Alternatively, as shown in FIG. 49, the cutting edges may only be located on the portions of the cutting wire within the tissue modification region 301 of the device.

As shown in FIGS. 50A and 50B, the tissue modification device may further include a spacer 406 within the tissue modification region 401, which may function to control the spacing between the parallel portions of the cutting wire(s) 403. FIGS. 50A and 50B illustrate an open spacer configuration, in which the spacer 406 only partially surrounds the circumference of the cutting wire(s) 403. An alternative embodiment is shown in FIG. 52C. As shown, the spacer 506 may surround the circumference of each cutting wire section 503.

In some embodiments, the spacer(s) 406 may be coupled to a substrate 407 positioned below or behind the cutting wires of the tissue modification region. The substrate, in some embodiments, may function to protect or shield non-target tissue, such as vessels or neural tissue. The spacers may be an integral portion of the substrate or may alternatively be connected, such as welded, to the substrate.

As shown in FIG. 51, the substrate or shield may further include slots or apertures 508. The apertures may function to allow the cut tissue to pass through the tissue modification region of the device. As described above, the tissue modification device may further include a spacer 506 within the tissue modification region, which may function to control the spacing between the parallel portions of the cutting wire(s) 503. In some embodiments, the spacer(s) 506 may be coupled to a substrate 507 positioned below or behind the cutting wires of the tissue modification region.

As shown in FIGS. 52A and 52B, the substrate 507 may include a tissue capture region 509. In some embodiments, the tissue capture region 509 may be a trough(s) or groove(s) configured to collect tissue between the cutting wires 503 and the substrate 507. In some embodiments, the substrate 507 may be spring loaded, via spring 510, to the proximal end (or distal end alternatively) of the device such that as the tissue capture region fills with tissue that substrate may move away from the cutting wires and increase the area between the cutting wires and the substrate to allow for increased tissue collection.

As shown in FIGS. 53A-53D, the cutting wire of the tissue modification device can be one of several embodiments. For example, as shown in FIG. 53A, the cutting wire may be a conventional Gigli wire. A Gigli wire is typically made of a first wire having a first diameter wrapped around a second wire having a second diameter. Typically, the second diameter is larger than the first diameter, but alternatively, they may have substantially the same diameter. In some embodiments, a first set of first and second wires may be wrapped around a second set of first and second wires. Alternatively, as shown in FIG. 53B, the cutting wire may include a single wire that is machined to include a helical or spiral cutting edge along the length of the wire. This wire may be machined by cutting a spiral or helical groove along the length of the wire. As shown in FIGS. 53C and 53D, the cutting wires may be formed by winding bunches of wires. For example, as shown in cross section in FIG. 53C, the cutting wire may comprise a 3 by 3 construction. In this embodiment, three wires are wrapped around one another. Then three sets of those three wire wraps are subsequently wrapped around each other. As shown in cross section in FIG. 53D, rather than initially wrapping three wires together, 6 wires may be wrapped together and then three sets of 6 may be wrapped together to form a 3 by 6 configuration. Each 6 wire set may be formed as a 7 wire set might be formed, but leaving one wire position empty.

Various embodiments of tissue modification devices and systems, as well as methods for making and using tissue modification devices and systems, are provided herein. In general, a flexible tissue-modification device as described herein is configured to remove tissue from a patient. In particular, these tissue-modification devices may be configured to perform tissue removal such as a Facetectomy. These devices typically include a flexible elongate body that extends proximally to distally (proximal/distal), and is configured to be inserted into a patient so that it extends around the target tissue (such as a facet joint of the spine), so that it can be pulled against the target tissue by applying tension to either

end of the device. Thus, the device may be extended into or through a spinal foramen, and/or around a spinal facet joint.

In one exemplary method of use, the device may be used to create a facetectomy. For example, the facetectomy may be created in anticipation of performing a spinal fusion. Alternatively, the device may be used in a surgical treatment for straightening a patient's spine that includes performing multiple posterior osteotomies (or facetectomies) to straighten a spine to normal degrees of kyphosis. This procedure may be known as a "Smith-Peterson" or "Ponte Osteotomies". Normally the vertebra contact each other through 3 joints at each level: one disc in the front, and two sliding facets in the back. In the thoracic spine, the facets look like shingles on a roof, and will only allow you to bend backward a fixed amount. In the osteotomy as shown in FIGS. 54A-54C, the facets are removed and the spine is bent backward further than normal. The device described herein may be used to remove the facet joints as shown.

Although much of the following description and accompanying figures generally focuses on surgical procedures in spine, in alternative embodiments, devices, systems and methods of the present invention may be used in any of a number of other anatomical locations in a patient's body. For example, in some embodiments, the flexible tissue modification devices of the present invention may be used in minimally invasive procedures in the shoulder, elbow, wrist, hand, hip, knee, foot, ankle, other joints, or other anatomical locations in the body. Similarly, although some embodiments may be used to remove or otherwise modify ligamentum flavum and/or bone in a spine to treat spinal stenosis, in alternative embodiments, other tissues may be modified to treat any of a number of other conditions. For example, in various embodiments, treated tissues may include but are not limited to ligament, tendon, bone, tumor, cyst, cartilage, scar, osteophyte, inflammatory tissue and the like. Non-target tissues may include neural tissue and/or neurovascular tissue in some embodiments or any of a number of other tissues and/or structures in other embodiments. Thus, various embodiments described herein may be used to modify any of a number of different tissues, in any of a number of anatomical locations in the body, to treat any of a number of different conditions.

The examples and illustrations included herein show, by way of illustration and not of limitation, specific embodiments in which the subject matter may be practiced. Other embodiments may be utilized and derived there from, such that structural and logical substitutions and changes may be made without departing from the scope of this disclosure. Such embodiments of the inventive subject matter may be referred to herein individually or collectively by the term "invention" merely for convenience and without intending to voluntarily limit the scope of this application to any single invention or inventive concept, if more than one is in fact disclosed. Thus, although specific embodiments have been illustrated and described herein, any arrangement calculated to achieve the same purpose may be substituted for the specific embodiments shown. This disclosure is intended to cover any and all adaptations or variations of various embodiments. Combinations of the above embodiments, and other embodiments not specifically described herein, will be apparent to those of skill in the art upon reviewing the above description.

What is claimed is:

1. A bimanually controlled tissue modification device for cutting tissue in a patient, the device comprising:
 - a tissue modification region;

41

at least two flexible elongate lengths of cable, wherein the lengths of cable extend substantially adjacent to each other proximally to distally;
 a plurality of rungs extending between the lengths of cable, wherein the rungs are proximal to the tissue modification region of the device;
 at least one region of each length of cable that is within the tissue modification region which is configured as a cutting member;
 a spacer extending between the cutting members and comprising a plurality of restraints at outer edges of the spacer and configured to releasably hold the cutting members apart from one another until the cutting members have cut into tissue to a depth that is greater than a thickness of the cutting member; and
 a guidewire coupler at the distal end region of the device configured to engage a tip of a guidewire.

2. The device of claim 1, wherein the flexible elongate lengths of cable link adjacent rungs.

3. The device of claim 1, wherein the cutting members and the cable are integrally formed.

4. The device of claim 1, wherein the cutting members are coupled to the cable.

5. The device of claim 1, wherein distal ends of the flexible elongate lengths of cable are secured together.

6. The device of claim 1, wherein proximal ends of the flexible elongate lengths of cable are secured together.

7. The device of claim 1, wherein the tissue modification region is configured to be actuated by pulling on a proximal handle and a distal guidewire coupled to the guidewire coupler.

8. The device of claim 1, wherein the guidewire coupler is configured such that the device is removably attachable to a proximal end region of a guidewire such that the tissue modification region can be pulled into position by pulling on the guidewire while the proximal end region of the guidewire is secured to the guidewire coupler.

9. The device of claim 1, wherein at least one cutting member comprises an elongate wire having a helical cutting edge along the length of the wire.

42

10. The device of claim 1, wherein the plurality of rungs are proximal and distal to the tissue modification region of the device.

11. A bimanually controlled tissue modification device for cutting tissue in a patient, the device comprising:

a tissue modification region;

at least two flexible elongate lengths of cable, wherein the lengths of cable extend substantially adjacent to each other proximally to distally and at least one region of each length of cable is a cutting member;

a spacer extending between the cutting members and comprising a plurality of restraints at outer edges of the spacer and configured to releasably hold the cutting members apart from one another until the cutting members have cut into tissue to a depth that is greater than a thickness of the cutting member; and

a guidewire coupler at the distal end region of the device configured to engage a tip of a guidewire.

12. The device of claim 11, wherein the cutting members and the cable are integrally formed.

13. The device of claim 11, wherein the cutting members are coupled to the cable.

14. The device of claim 11, wherein distal ends of the flexible elongate lengths of cable are secured together.

15. The device of claim 11, wherein the tissue modification region is configured to be actuated by pulling on a proximal handle and a distal guidewire coupled to the guidewire coupler.

16. The device of claim 11, wherein the guidewire coupler is configured such that the device is removably attachable to a proximal end region of a guidewire such that the tissue modification region can be pulled into position by pulling on the guidewire while the proximal end region of the guidewire is secured to the guidewire coupler.

17. The device of claim 11, wherein at least one cutting member comprises an elongate wire having a helical cutting edge along the length of the wire.

* * * * *