



US008389271B2

(12) **United States Patent**
Wright et al.

(10) **Patent No.:** **US 8,389,271 B2**
(45) **Date of Patent:** ***Mar. 5, 2013**

(54) **METHOD AND APPARATUS FOR CONTROLLING AIR PRESSURE IN AN ORGAN OR TISSUE CONTAINER**

(75) Inventors: **David Walter Wright**, Littleton, CO (US); **Douglas Schein**, Arlington Heights, IL (US); **John Brassil**, Northbrook, IL (US)

(73) Assignee: **Organ Recovery Systems, Inc.**, Itasca, IL (US)

(*) Notice: Subject to any disclaimer, the term of this patent is extended or adjusted under 35 U.S.C. 154(b) by 58 days.

This patent is subject to a terminal disclaimer.

(21) Appl. No.: **12/654,772**

(22) Filed: **Dec. 31, 2009**

(65) **Prior Publication Data**

US 2010/0112542 A1 May 6, 2010

Related U.S. Application Data

(63) Continuation of application No. 10/815,820, filed on Apr. 2, 2004, now Pat. No. 7,678,563.

(60) Provisional application No. 60/459,986, filed on Apr. 4, 2003.

(51) **Int. Cl.**

A01N 1/00 (2006.01)

A01N 1/02 (2006.01)

B01F 3/04 (2006.01)

(52) **U.S. Cl.** **435/284.1**; 435/1.1; 435/1.2; 435/1.3; 435/289.1; 435/303.1; 435/304.1; 62/306; 62/371; 62/372; 62/375; 62/457.1; 62/457.2; 62/457.9; 62/64; 62/78

(58) **Field of Classification Search** 435/284.1, 435/1.1, 1.2, 1.3, 289.1, 303.1, 304.1; 62/306, 62/371, 372, 375, 457.1, 457.2, 457.9, 64, 62/78

See application file for complete search history.

(56) **References Cited**

U.S. PATENT DOCUMENTS

1,682,344 A	8/1928	Lesieur
1,916,658 A	7/1933	Davidson
3,406,531 A	10/1968	Swenson et al.
3,545,221 A	12/1970	Swenson et al.
3,545,225 A	12/1970	Swenson
3,607,646 A	9/1971	de Roissart
3,632,473 A	1/1972	Belzer
3,639,084 A	2/1972	Goldhaber
3,654,085 A	4/1972	Norr et al.
3,660,241 A	5/1972	Michielsen
3,712,583 A	1/1973	Martindale et al.
3,738,914 A	6/1973	Thorne et al.

(Continued)

FOREIGN PATENT DOCUMENTS

EP	0 337 677 A2	10/1989
FR	2 583 386 A1	12/1986

(Continued)

OTHER PUBLICATIONS

U.S. Appl. No. 60/459,981, filed Apr. 4, 2003, Wright et al.

(Continued)

Primary Examiner — Nathan Bowers

(74) *Attorney, Agent, or Firm* — Oliff & Berridge, PLC

(57) **ABSTRACT**

An organ perfusion apparatus and method monitor, sustain and/or restore viability of organs and preserve organs for storage and/or transport. Other apparatus include an organ transporter, an organ cassette and an organ diagnostic device. The apparatus and methods include the organ cassette with one or more openings configured to allow tubing to pass through the openings and be connected to the organ or tissue within the cassette, and including a pressure control device to allow pressure inside the portable housing to be varied.

38 Claims, 13 Drawing Sheets

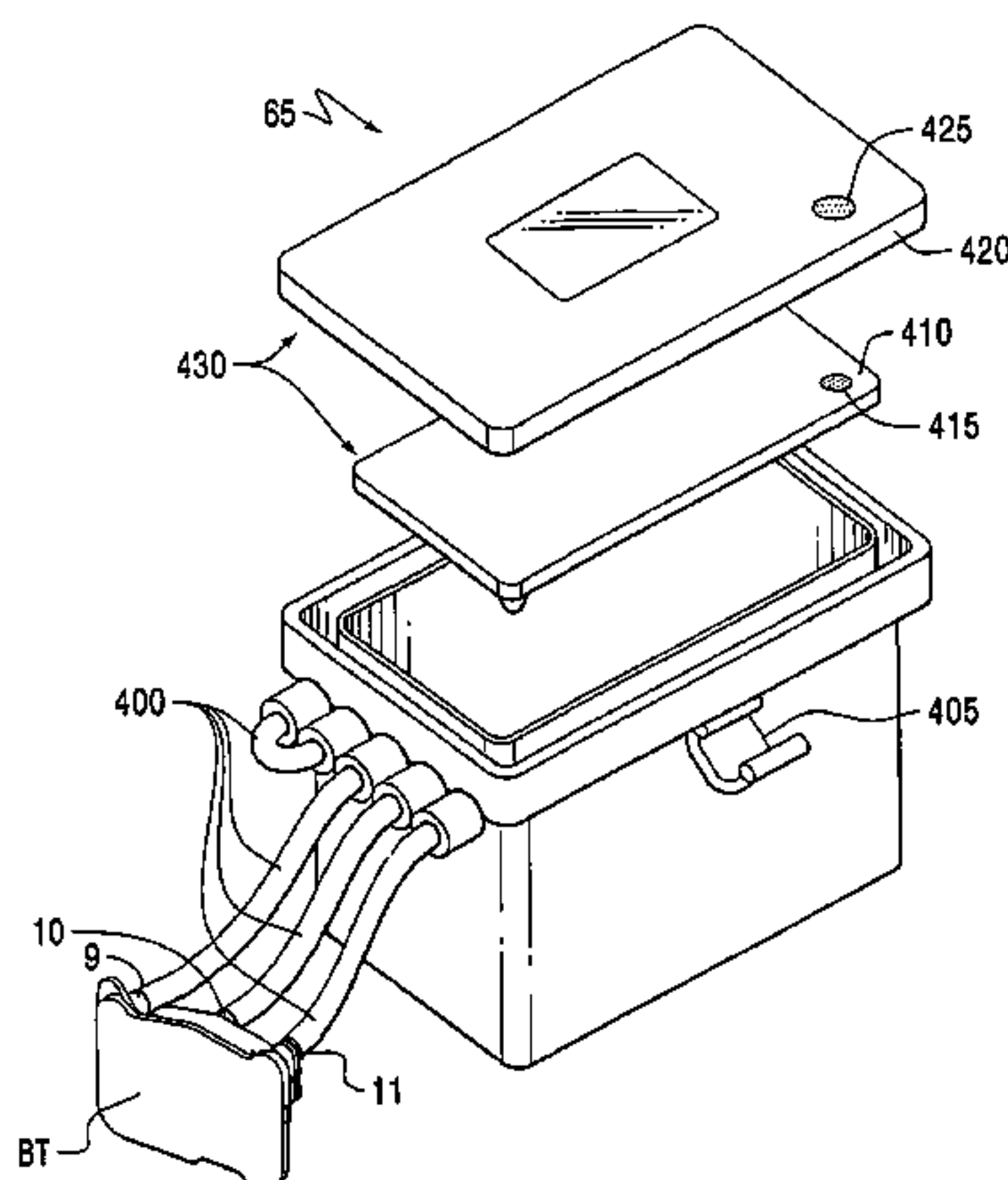

U.S. PATENT DOCUMENTS

3,753,865	A	8/1973	Belzer et al.	5,599,659	A	2/1997	Brasile et al.
3,772,153	A	11/1973	de Roissart	5,622,429	A	4/1997	Heinze
3,777,507	A	12/1973	Burton et al.	5,643,712	A	7/1997	Brasile
3,810,367	A	5/1974	Peterson	5,681,740	A	10/1997	Messier et al.
3,843,455	A	10/1974	Bier	5,699,793	A	12/1997	Brasile
3,845,974	A	11/1974	Pelloux-Gervais	5,702,881	A	12/1997	Brasile et al.
3,877,843	A	4/1975	Fischel	5,709,654	A	1/1998	Klatz et al.
3,881,990	A	5/1975	Burton et al.	5,712,084	A	1/1998	Osgood
3,892,628	A	7/1975	Thorne et al.	5,716,378	A	2/1998	Minten
3,914,954	A	10/1975	Doerig	5,723,282	A	3/1998	Fahy et al.
3,935,065	A	1/1976	Doerig	5,730,720	A	3/1998	Sites et al.
3,962,439	A	6/1976	Yokoyama et al.	5,752,929	A	5/1998	Klatz et al.
3,995,444	A	12/1976	Clark et al.	5,821,045	A	10/1998	Fahy et al.
4,186,565	A	2/1980	Toledo-Pereyra	5,823,986	A	10/1998	Peterson
4,231,354	A	11/1980	Kurtz et al.	5,827,222	A	10/1998	Klatz et al.
4,242,883	A	1/1981	Toledo-Pereyra	5,843,024	A	12/1998	Brasile
4,243,883	A	1/1981	Schwarzmann	5,856,081	A	1/1999	Fahy
4,378,797	A	4/1983	Osterholm	5,879,329	A	3/1999	Ginsburg
4,393,863	A	7/1983	Osterholm	5,928,182	A	7/1999	Kraus et al.
4,445,500	A	5/1984	Osterholm	5,965,433	A	10/1999	Gardetto et al.
4,451,251	A	5/1984	Osterholm	6,024,698	A	2/2000	Brasile
4,460,102	A	7/1984	Barringer	6,046,046	A	4/2000	Hassanein
4,462,215	A	7/1984	Kuraoka et al.	6,100,082	A	8/2000	Hassanein
4,471,629	A	9/1984	Toledo-Pereyra	6,582,953	B2	6/2003	Brasile
4,473,637	A	9/1984	Guibert	6,673,594	B1	1/2004	Owen et al.
4,474,016	A	10/1984	Winchell	6,677,150	B2	1/2004	Alford et al.
4,494,385	A	1/1985	Kuraoka et al.	6,953,655	B1	10/2005	Hassanein et al.
4,502,295	A	3/1985	Toledo-Pereyra	2004/0029266	A1	2/2004	Barbera-Guillem
4,559,298	A	12/1985	Fahy				
4,596,250	A	6/1986	Beisang, III et al.				
4,618,586	A	10/1986	Walker				
4,629,686	A	12/1986	Gruenberg				
4,657,532	A	4/1987	Osterholm				
4,666,425	A	5/1987	Fleming				
4,704,029	A	11/1987	Van Heuvelen				
4,717,548	A	1/1988	Lee				
4,723,974	A	2/1988	Ammerman				
4,745,759	A	5/1988	Bauer et al.				
4,766,740	A	8/1988	Bradley et al.				
4,801,299	A	1/1989	Brendel et al.				
4,837,390	A	6/1989	Reneau				
4,879,283	A	11/1989	Belzer et al.				
4,951,482	A	8/1990	Gilbert				
4,958,506	A	9/1990	Guilhem et al.				
5,003,787	A	4/1991	Zlobinsky				
5,013,303	A	5/1991	Tamari et al.				
5,028,588	A	7/1991	Hoffman et al.				
5,036,097	A	7/1991	Floyd et al.				
5,047,395	A	9/1991	Wu				
5,051,352	A	9/1991	Martindale et al.				
5,066,578	A	11/1991	Wikman-Coffelt				
5,085,630	A	2/1992	Osterholm et al.				
5,110,721	A	5/1992	Anaise et al.				
5,130,230	A	7/1992	Segall et al.				
5,141,847	A	8/1992	Sugimachi et al.				
5,145,771	A	9/1992	Lemasters et al.				
5,149,321	A	9/1992	Klatz et al.				
5,157,930	A	10/1992	McGhee et al.				
5,200,176	A	4/1993	Wong et al.				
5,216,032	A	6/1993	Manning				
5,217,860	A	6/1993	Fahy et al.				
5,234,405	A	8/1993	Klatz et al.				
5,285,657	A	2/1994	Bacchi et al.				
5,326,706	A	7/1994	Yland et al.				
5,328,821	A	7/1994	Fisher et al.				
5,338,662	A	8/1994	Sadri				
5,356,771	A	10/1994	O'Dell				
5,362,622	A	11/1994	O'Dell et al.				
5,383,854	A	1/1995	Safar et al.				
5,385,821	A	1/1995	O'Dell et al.				
5,395,314	A	3/1995	Klatz et al.				
5,434,045	A	7/1995	Jost				
5,437,633	A	8/1995	Manning				
5,472,876	A	12/1995	Fahy				
5,476,763	A	12/1995	Bacchi et al.				
5,494,822	A	2/1996	Sadri				
5,584,804	A	12/1996	Klatz et al.				
5,586,438	A	12/1996	Fahy				

FOREIGN PATENT DOCUMENTS

WO	WO 86/00812	12/1986
WO	WO 91/09520	7/1991
WO	WO 94/06292	3/1994
WO	WO 96/12191	4/1996
WO	WO 96/29865	10/1996
WO	WO 96/30111	10/1996
WO	WO 96/31779	10/1996
WO	WO 96/32074	10/1996
WO	WO 96/32157	10/1996
WO	WO 96/39027	12/1996
WO	WO 97/22003	6/1997
WO	WO 97/28449	8/1997
WO	WO 88/05261	7/1998
WO	WO 00/18226	4/2000
WO	WO 02/18210 A1	3/2002
WO	WO 02/26034 A2	4/2002

OTHER PUBLICATIONS

U.S. Appl. No. 60/460,875, filed Apr. 8, 2003, Wright et al.

"Randomized Clinical Study of Thiopental Loading in Comatose Survivors of Cardiac Arrest", *The New England Journal of Medicine*, vol. 314, No. 7, pp. 397-403, Feb. 1996.

"Free Radicals and Myocardial Ischemia and Reperfusion Injury", Paul J. Simpson et al., *J Lab Clin Med.*, pp. 13-30, Jul. 1987.

"Development of an Isolated Perfused Dog Kidney With Improved Function", William H. Waugh et al., *American Journal of Physiology*, vol. 217, No. 1, Jul. 1969.

"Variations in Vascular Resistance of Isolated Rat Hearts During Normothermic and Hypothermic Experiments", C.G. Adem et al., *J. Biomed. Engng.*, vol. 3(2), pp. 128-133, 1981.

"Effect of Pharmacologic Agents on the Function of the Hypothermically Preserved Dog Kidney During Normothermic Reperfusion", Rutger J. Ploeg et al., *Surgery*, vol. 103, No. 6, pp. 676-682, Jun. 1988.

"The Beneficial Effect of Intermediate Normothermic Perfusion During Cold Storage of Ischemically Injured Kidneys", Jos G. Maessen et al., *Transplantation*, vol. 47, No. 3, pp. 409-414, Mar. 1989.

"The Asystolic, or Non-Heartbeating, Donor", Gauke Kootstra, *Transplantation*, vol. 63, No. 7, pp. 917-921, 1997.

"Normothermic Renal Artery Perfusion: A Comparison of Perfusates", John D. Hughes et al., *Annals of Vascular Surgery*, vol. 10, pp. 123-130, 1996.

"Is Normothermic Preservation an Alternative to Hypothermic Preservation?", R. N. Dunn et al., *Organ Preservation Basic and Applied Aspects*, Chapter 38, pp. 273-277, 1982.

- “Studies of Controlled Reperfusion After Ischemia”, Pierre L. Julia, MD et al., *The Journal of Thoracic and Cardiovascular Surgery*, vol. 101, No. 2, pp. 303-313, Feb. 1991.
- “Urinary π -Class Glutathione Transferase as an Indicator of Tubular Damage in the Human Kidney”, Dr. Anders Sundberg et al., *Nephron*, vol. 67, pp. 308-316, 1994.
- “Effect of Ischemia and 24 Hour Reperfusion on ATP Synthesis in the Rat Kidney”, C.E. Irazu et al., *Journal of Experimental Pathology*, vol. 4, No. 1, pp. 29-36, 1989.
- “Intermediate Normothermic Hemoperfusion of Rat Kidneys: Functional Aspects and a Study into the Effect of Free Radical Scavengers”, A.O. Gaber, *Transplantation Proceedings*, vol. XX, No. 5, pp. 896-898, Oct. 1998.
- “Improvement of Postischemic Kidney Function by Reperfusion with a Specifically Developed Solution (BT01)”, Pierre Julia, MD et al., *Annals of Vascular Surgery*, vol. 9, pp. S-81-S-88, 1995.
- “Ischemia With Intermittent Reperfusion Reduces Functional and Morphologic Damage Following Renal Ischemia in the Rat”, Richard S. Frank, MD et al., *Annals of Vascular Surgery*, vol. 7, No. 2, pp. 150-155, 1993.
- “Graft Conditioning of Liver in Non-Heart-Beating Donors by an Artificial Heart and Lung Machine In Situ”, T. Endoh et al., *Transplantation Proceedings*, vol. 28, No. 1, pp. 110-115, Feb. 1996.
- “Machine Perfusion of Isolated Kidney At 37° C Using Pyridoxalated Hemoglobin-Polyoxyethylene (PHP) Solution, UW Solution and Its Combination”, T. Horiuchi et al., *Biomaterials, Art. Cells & Immob. Biotech*, vol. 20, Nos. 2-4,, pp. 549-555, 1992.
- “Analysis of the Optimal Perfusion Pressure and Flow Rate of the Renal Vascular Resistance and Oxygen Consumption in the Hypothermic Perfused Kidney”, R. Grundmann, M.D. et al., *Surgery*, vol. 77, No. 3, pp. 451-461, Mar. 1975.
- “An Experimental Model for Assessment of Renal Recovery from Warm Ischemia”, Paula Jablonski et al., *Transplantation*, vol. 35, No. 3, pp. 198-204, Mar. 1983.
- B.G. Rijkmans et al., “Six-Day Canine Kidney Preservation, Hypothermic Perfusion Combined with Isolated Blood Perfusion,” Feb. 1984, pp. 130-134.
- “Intermediate Normothermic Perfusion During Cold Storage of Ischemically Injured Kidney,” J.G. Maessen et al., *Transplantation Proceedings*, vol. 21, No. 1. Feb. 1989, pp. 1252-1253.

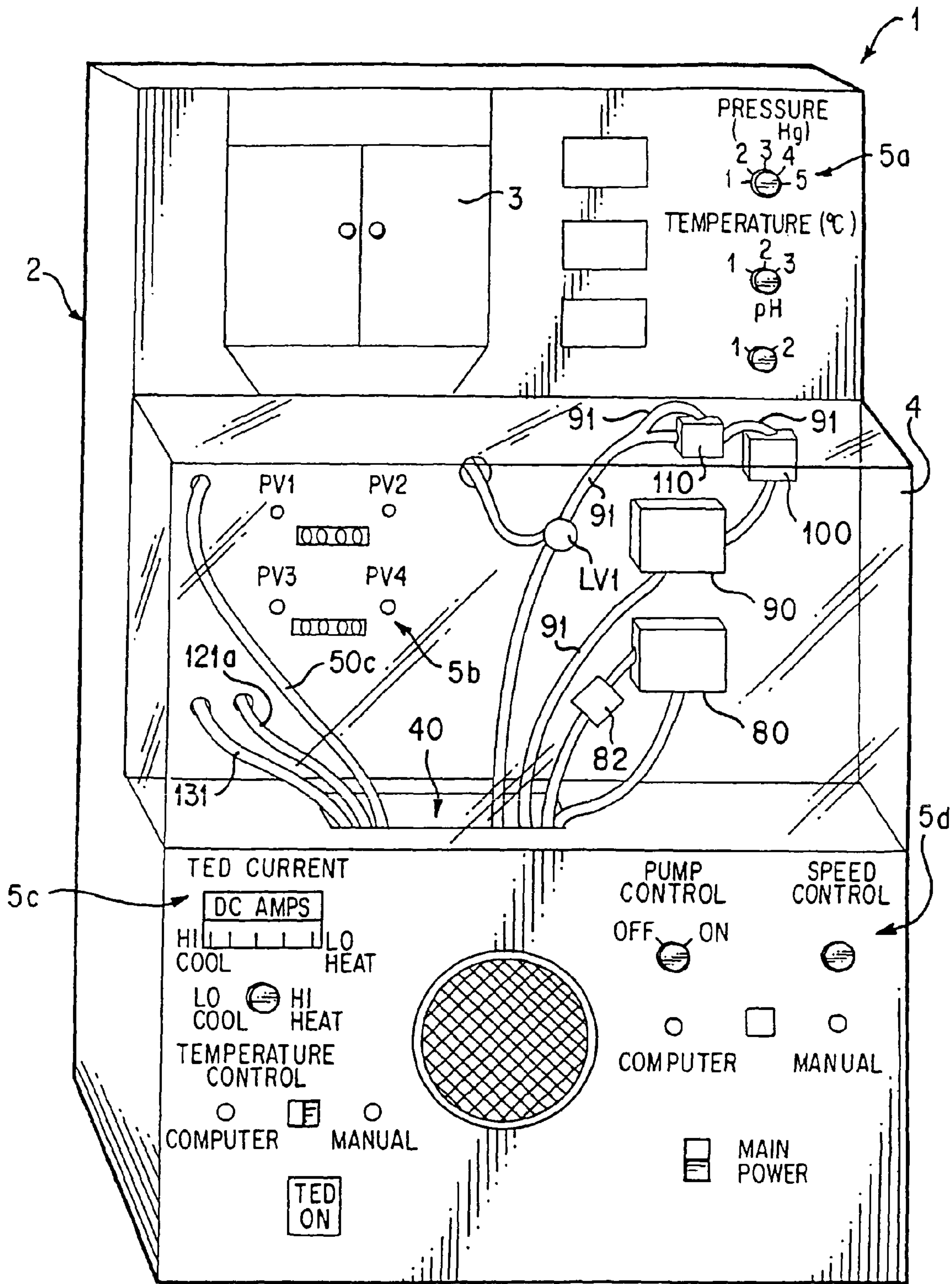

Fig. 1

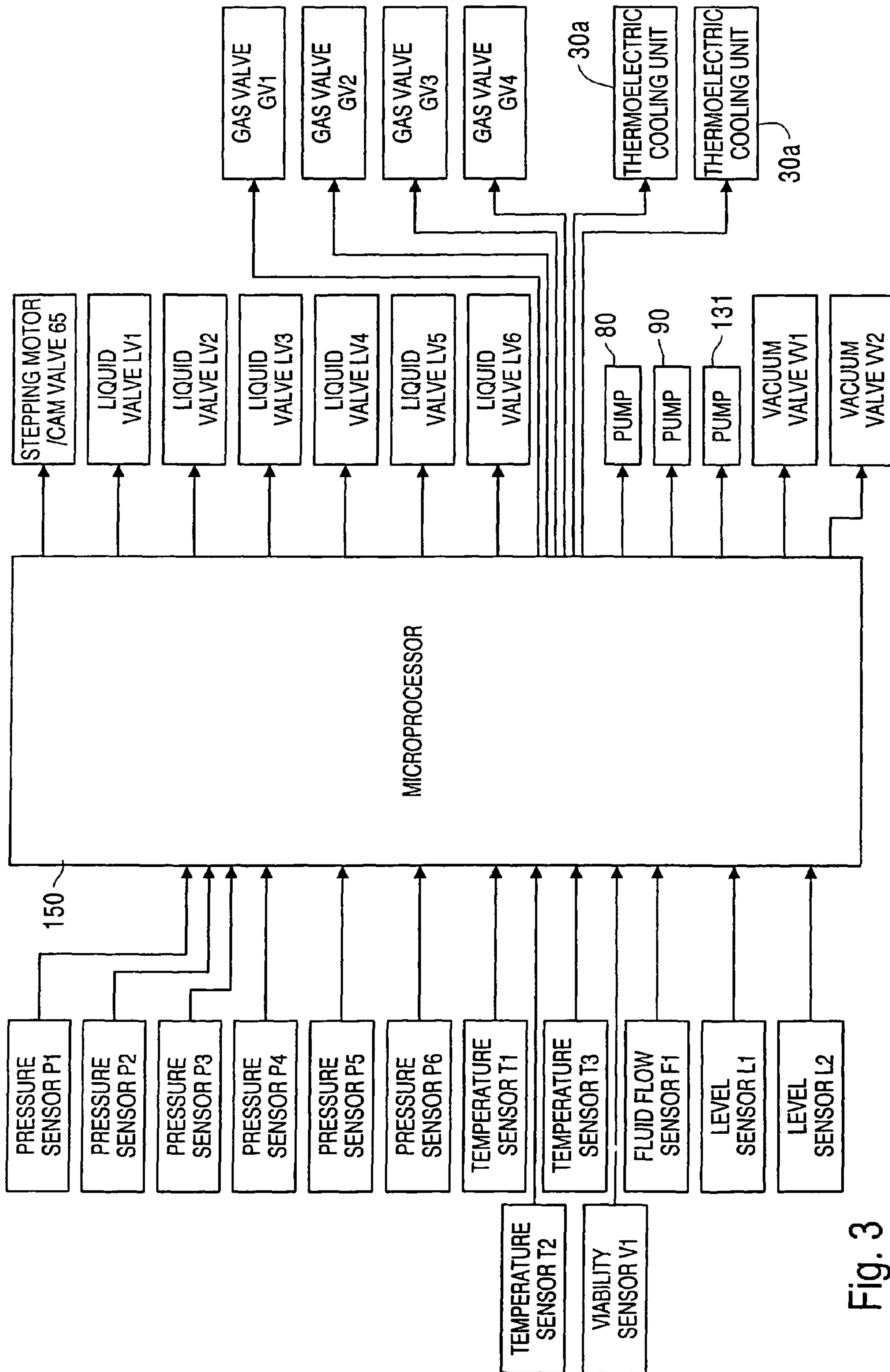

Fig. 3

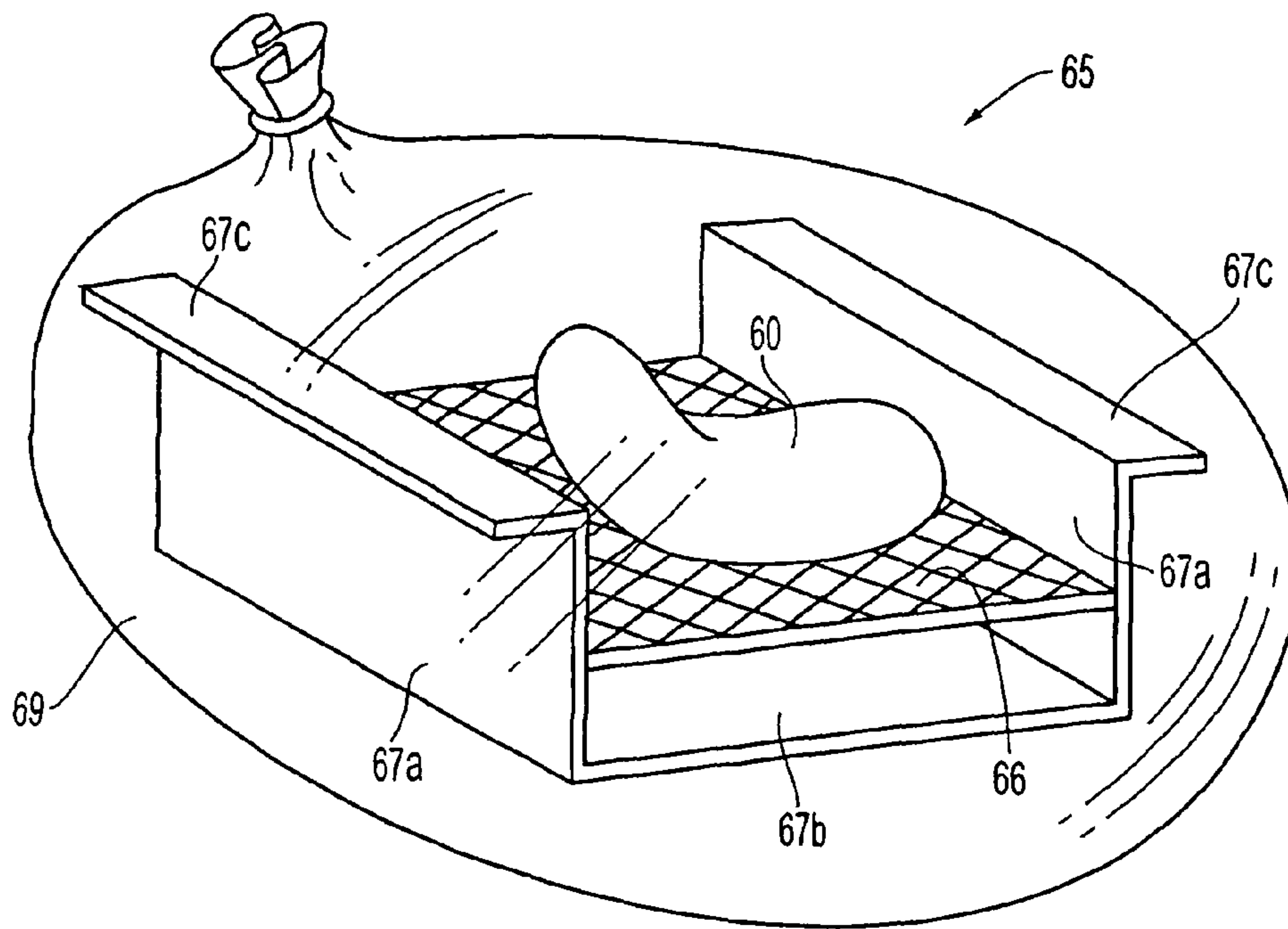

Fig. 4A

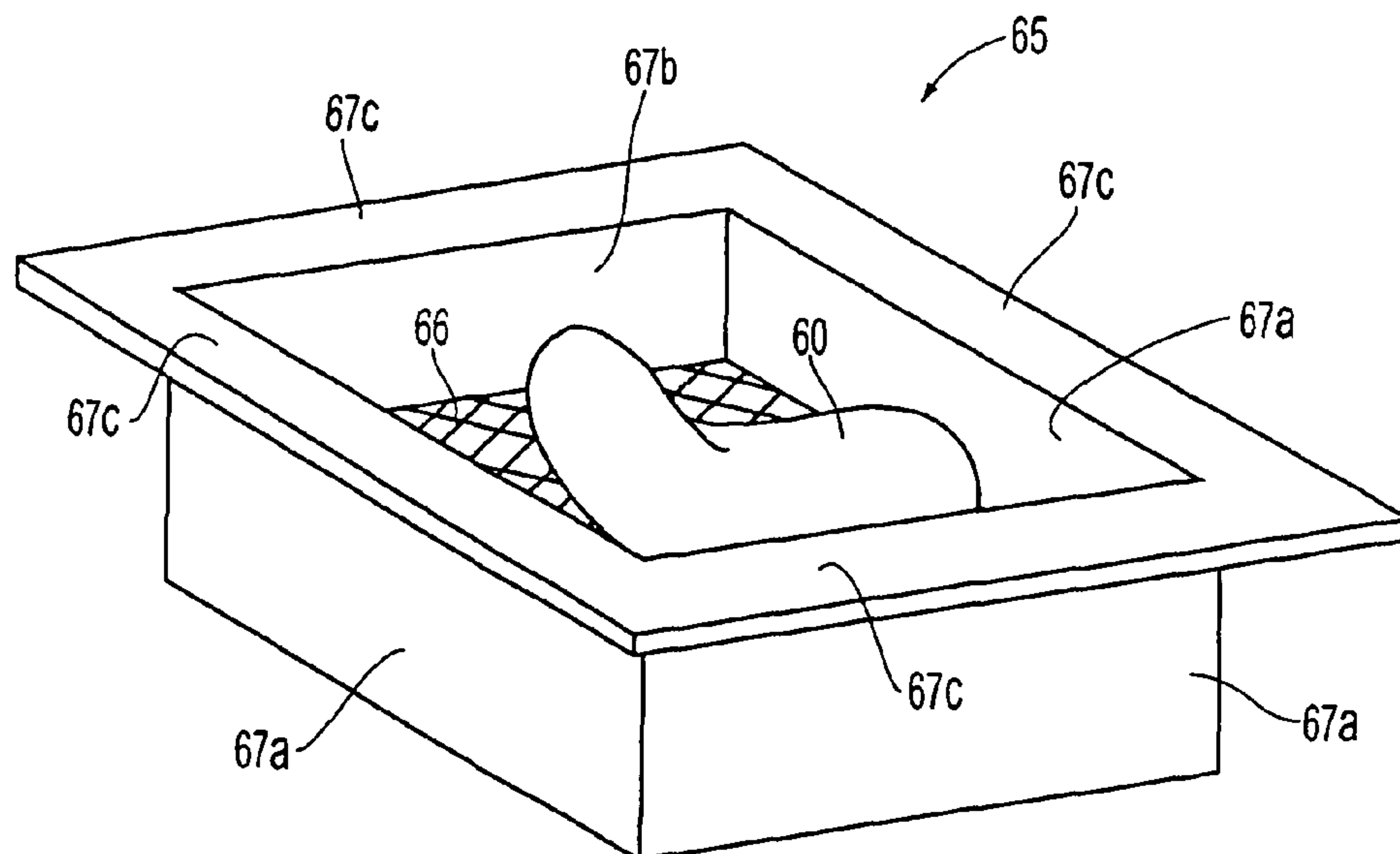

Fig. 4B

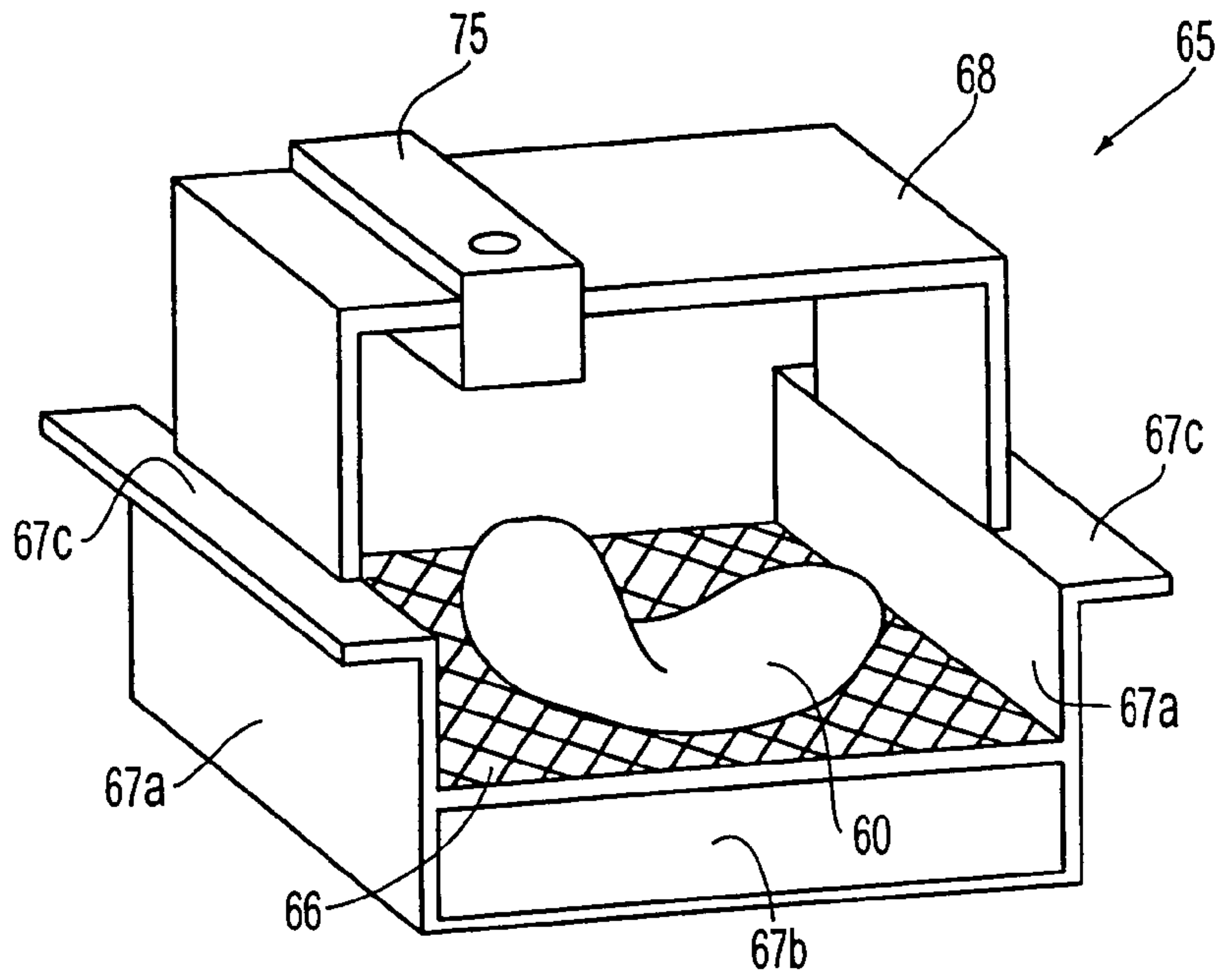

Fig. 4C

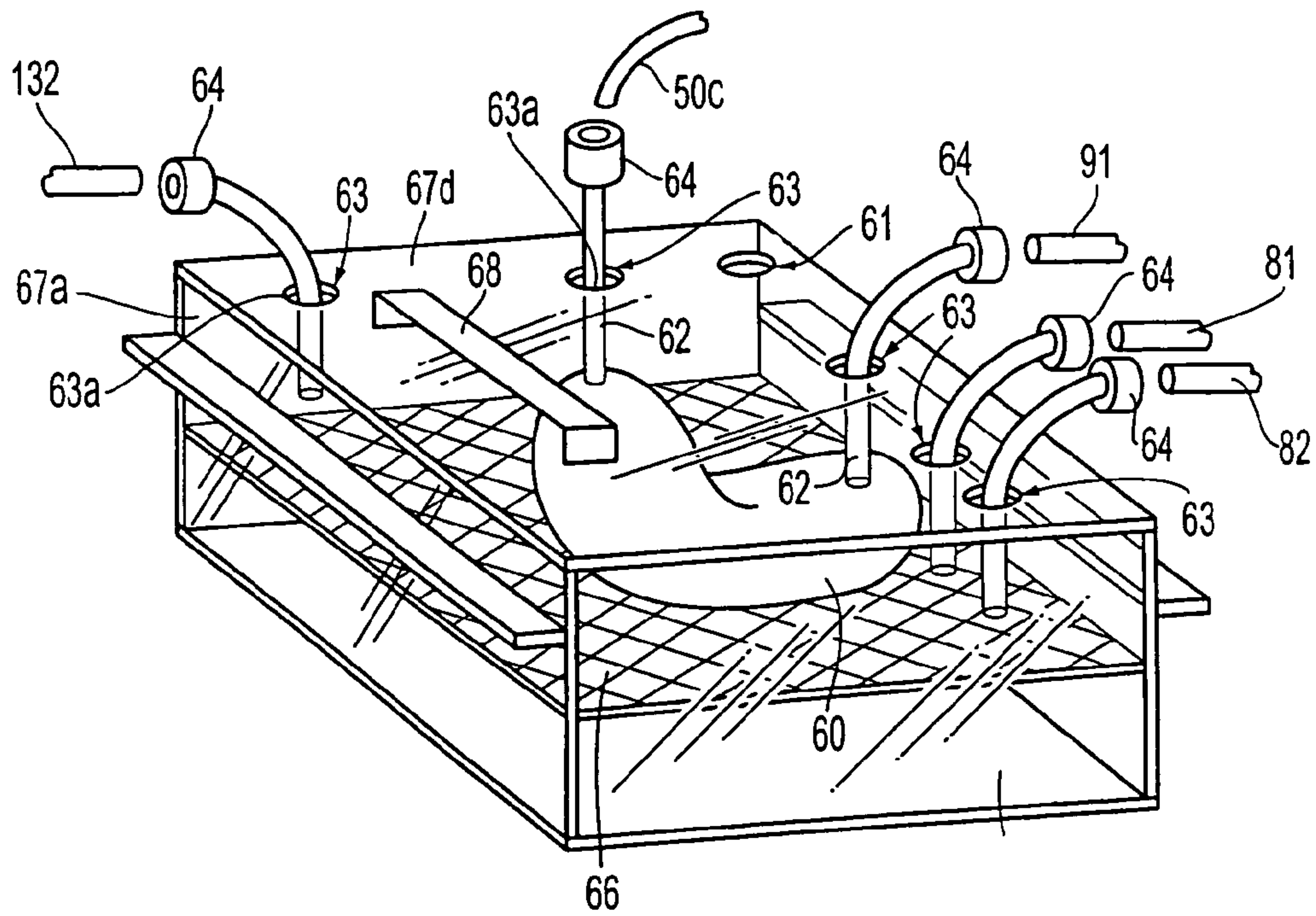

Fig. 4D

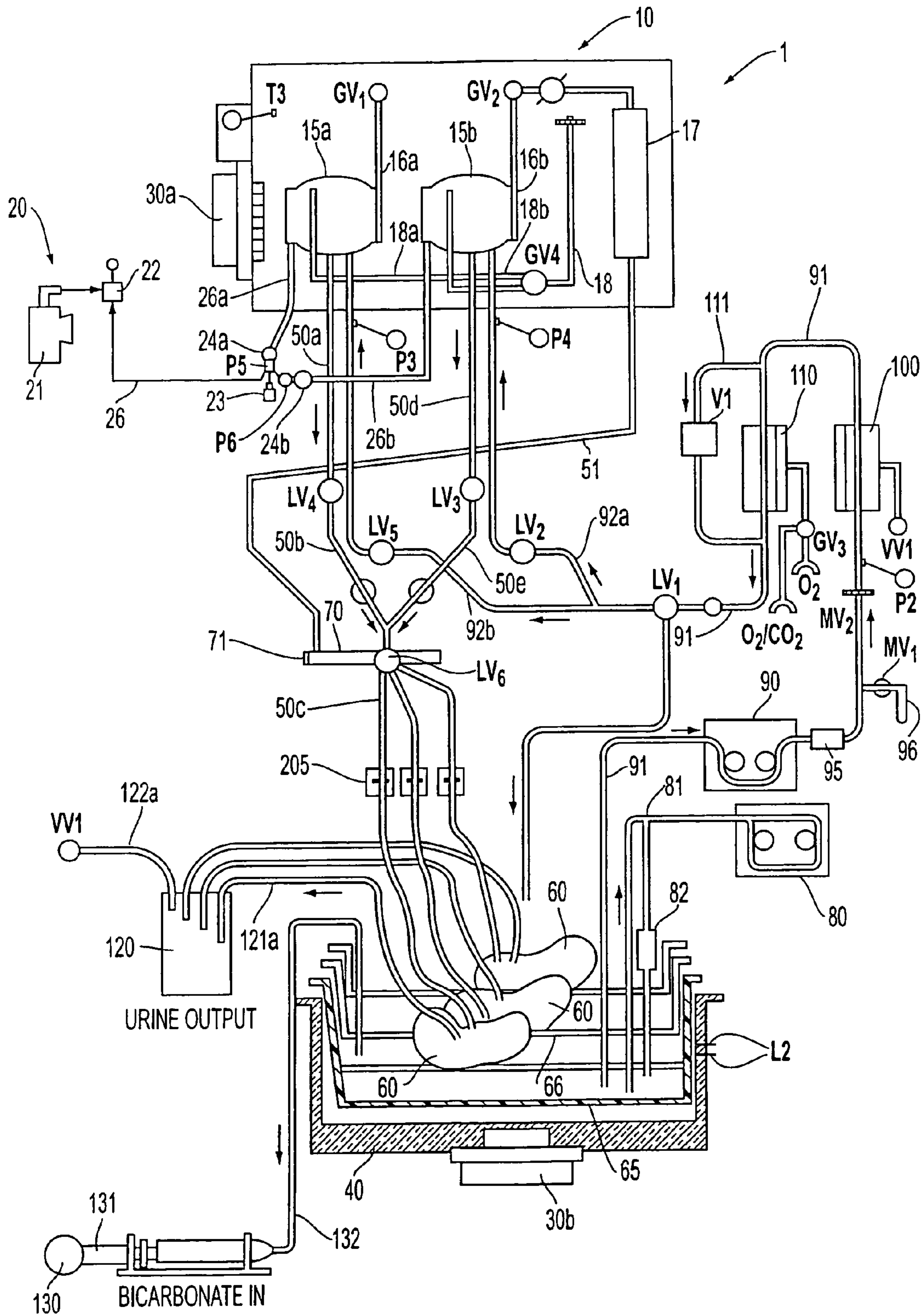

Fig. 5

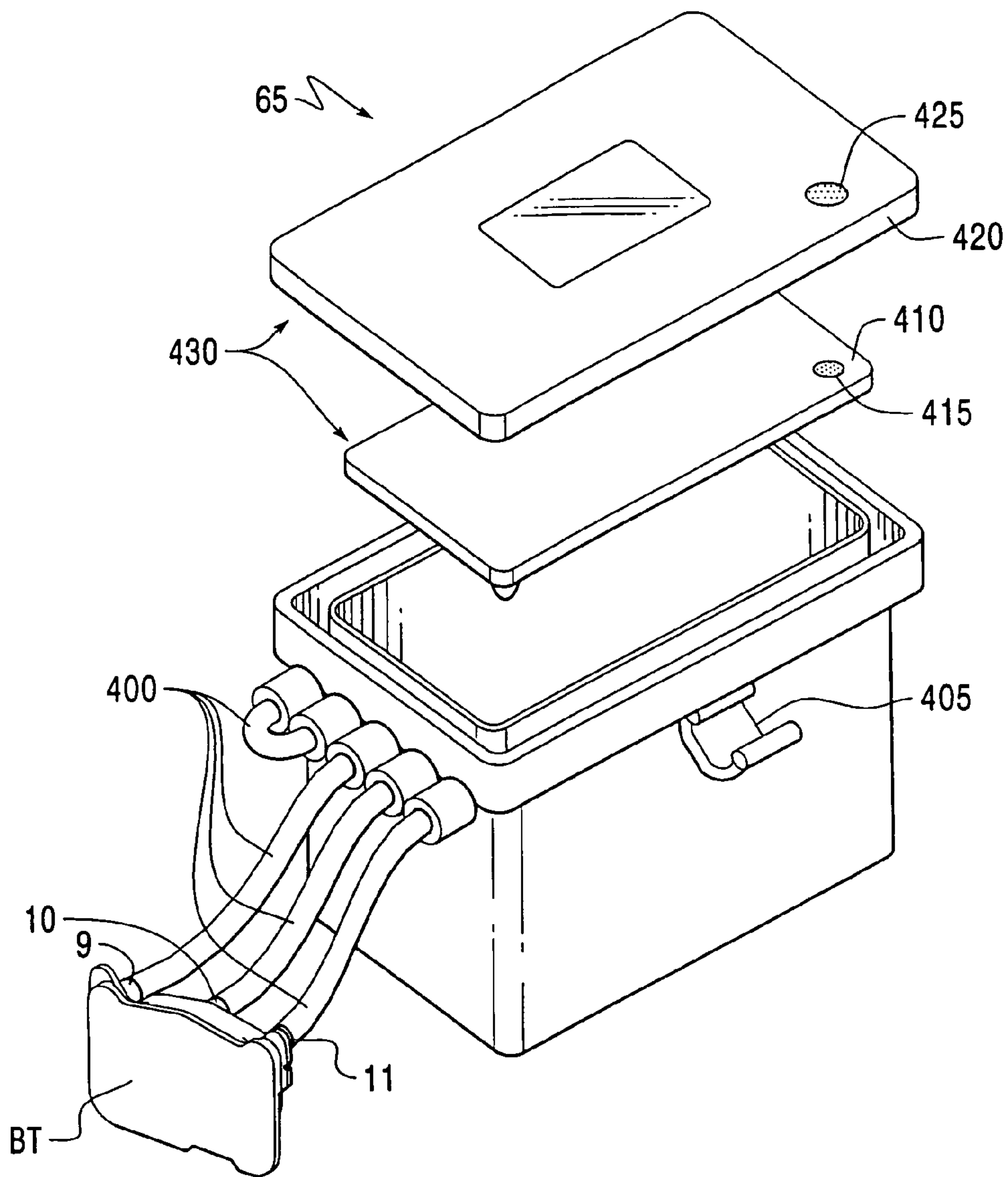

Fig. 6A

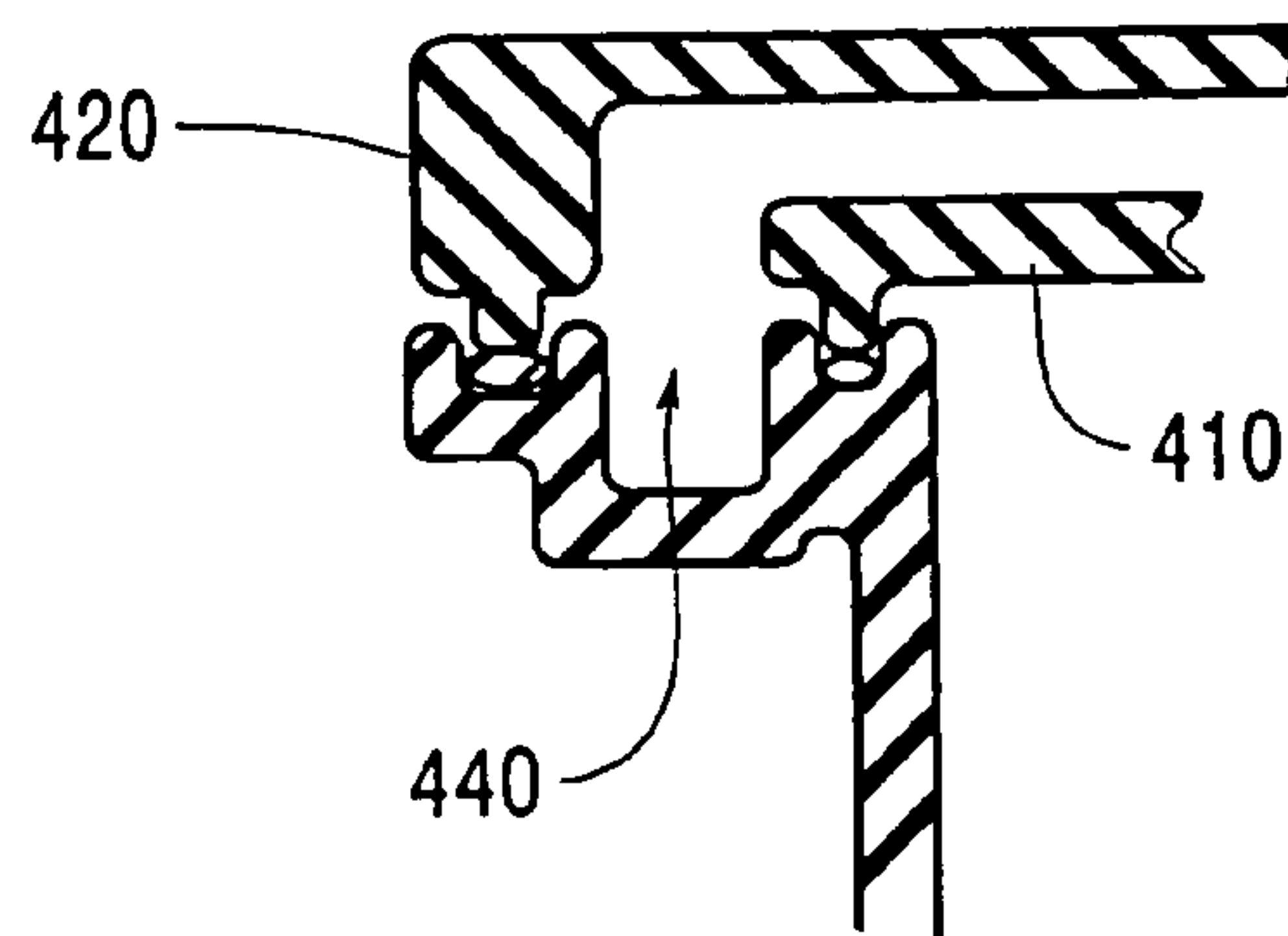

Fig. 6B

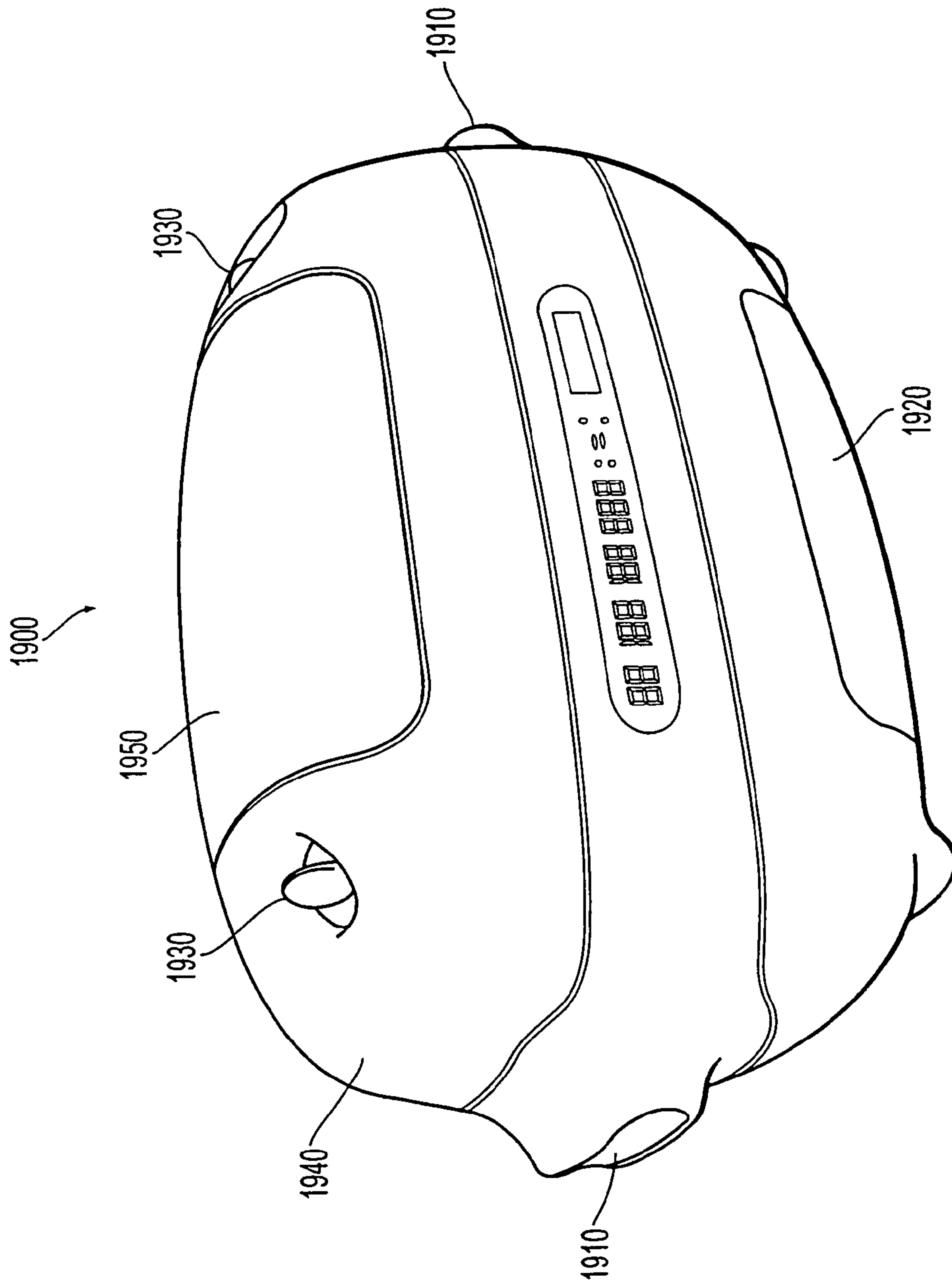

Fig. 7

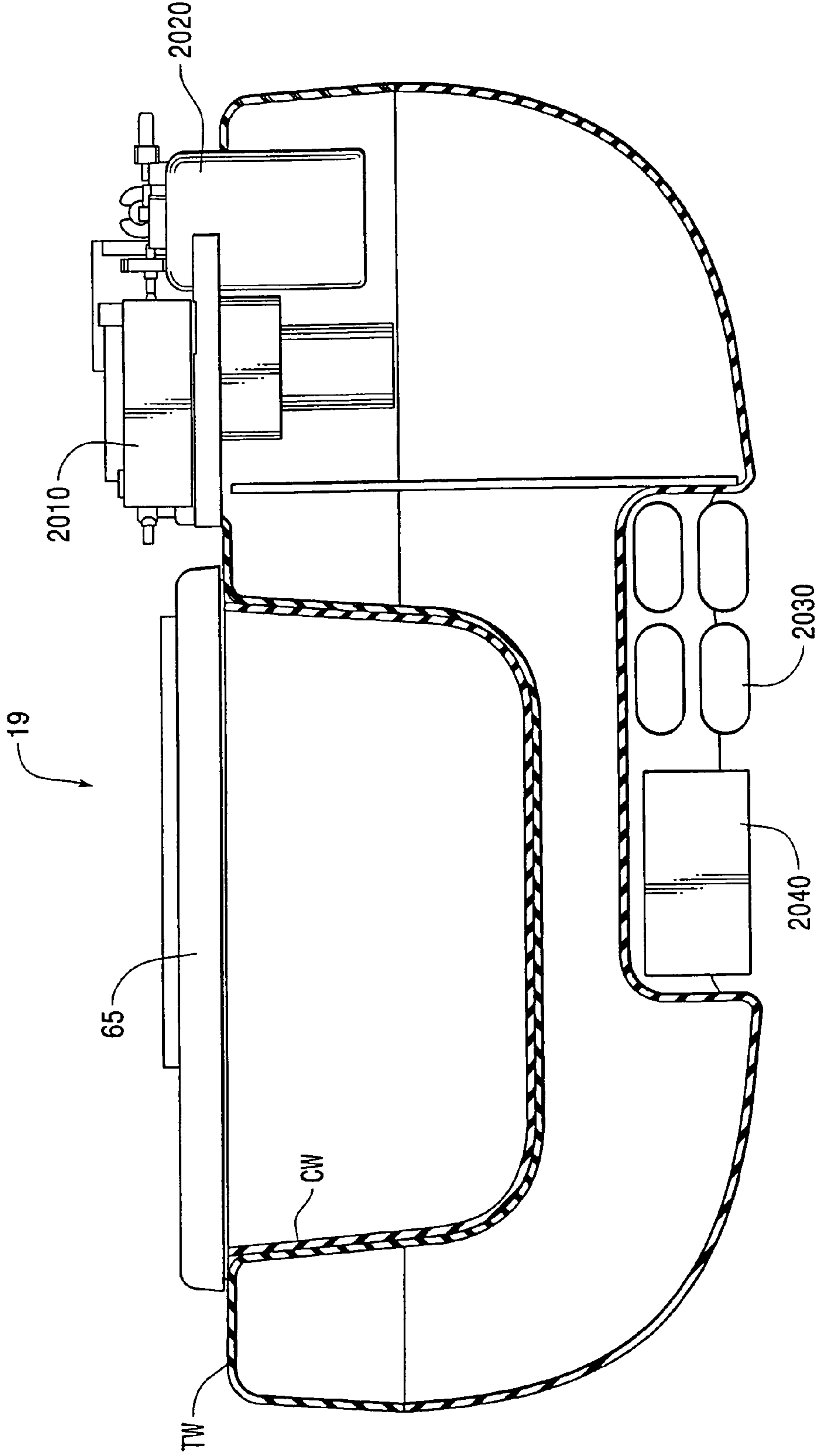

Fig. 8

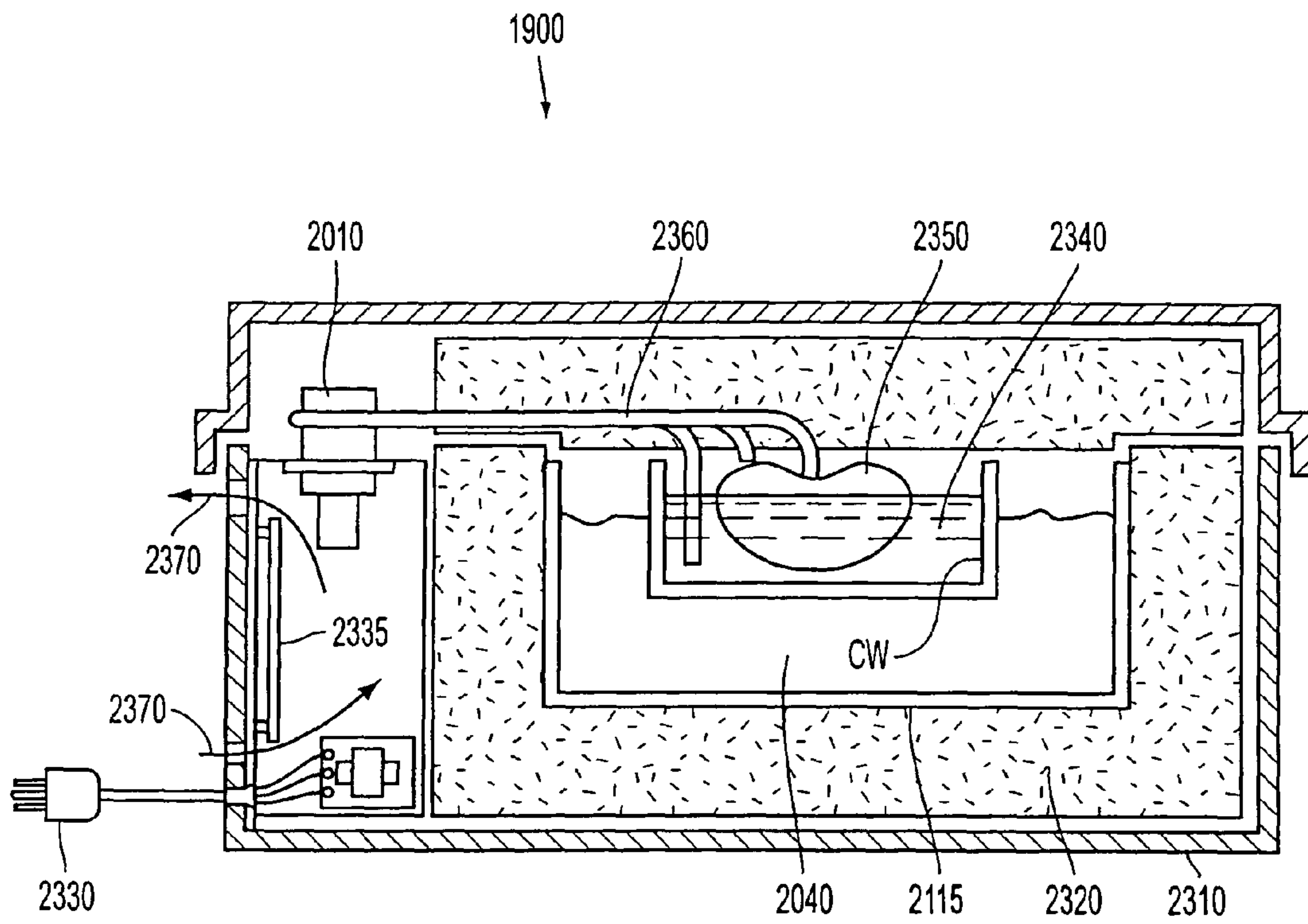

Fig. 9

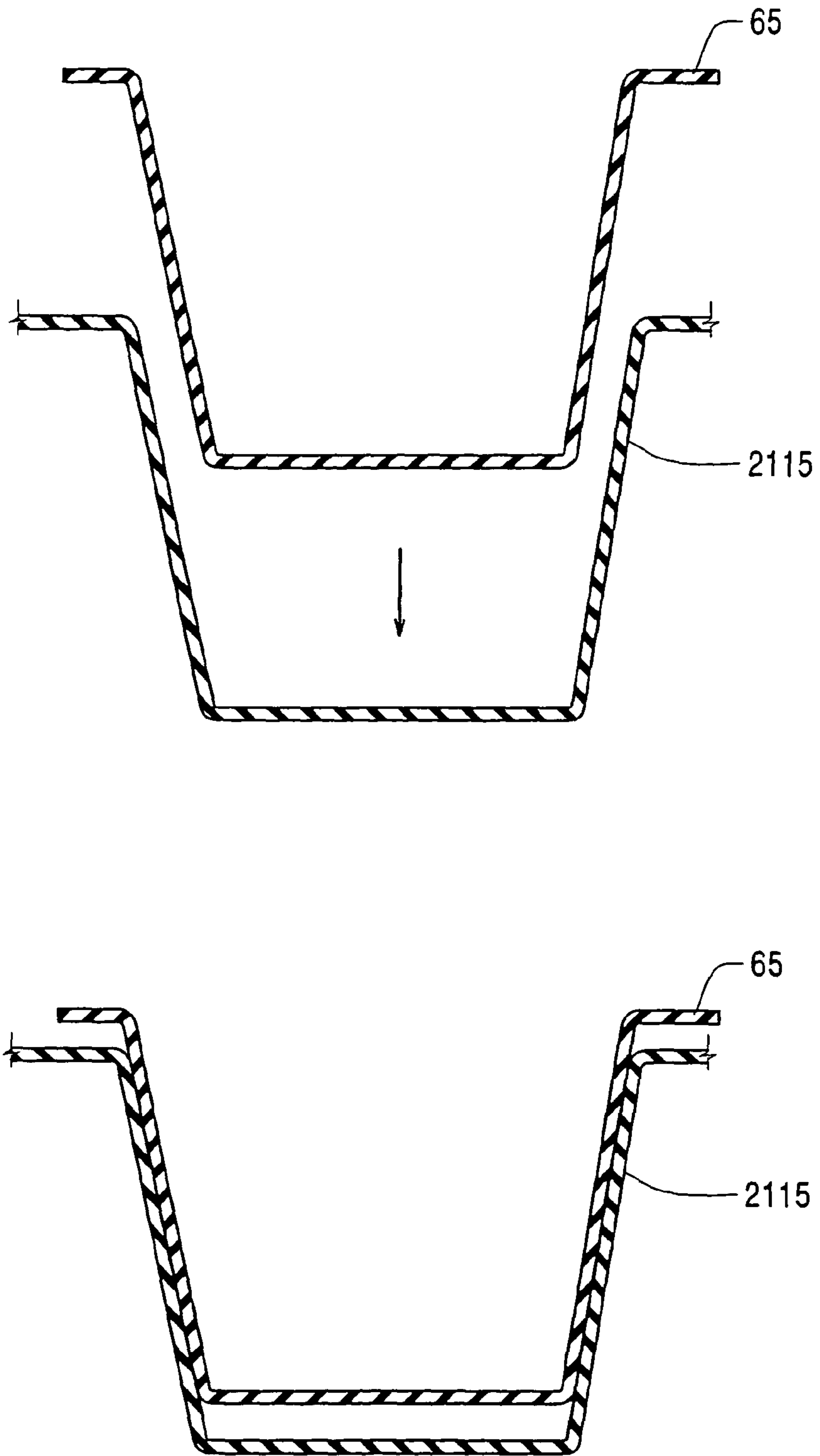

Fig. 10

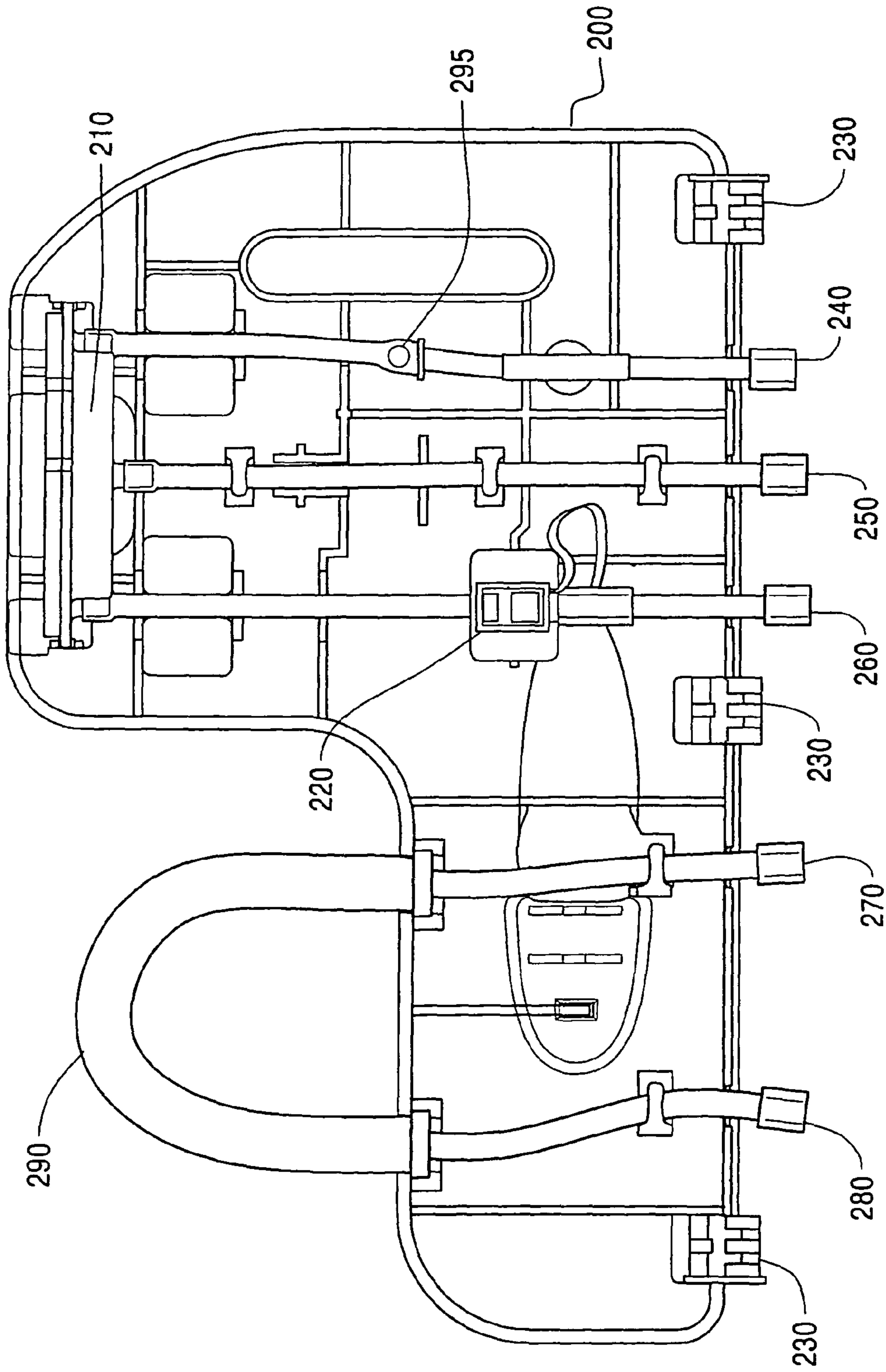

Fig. 11

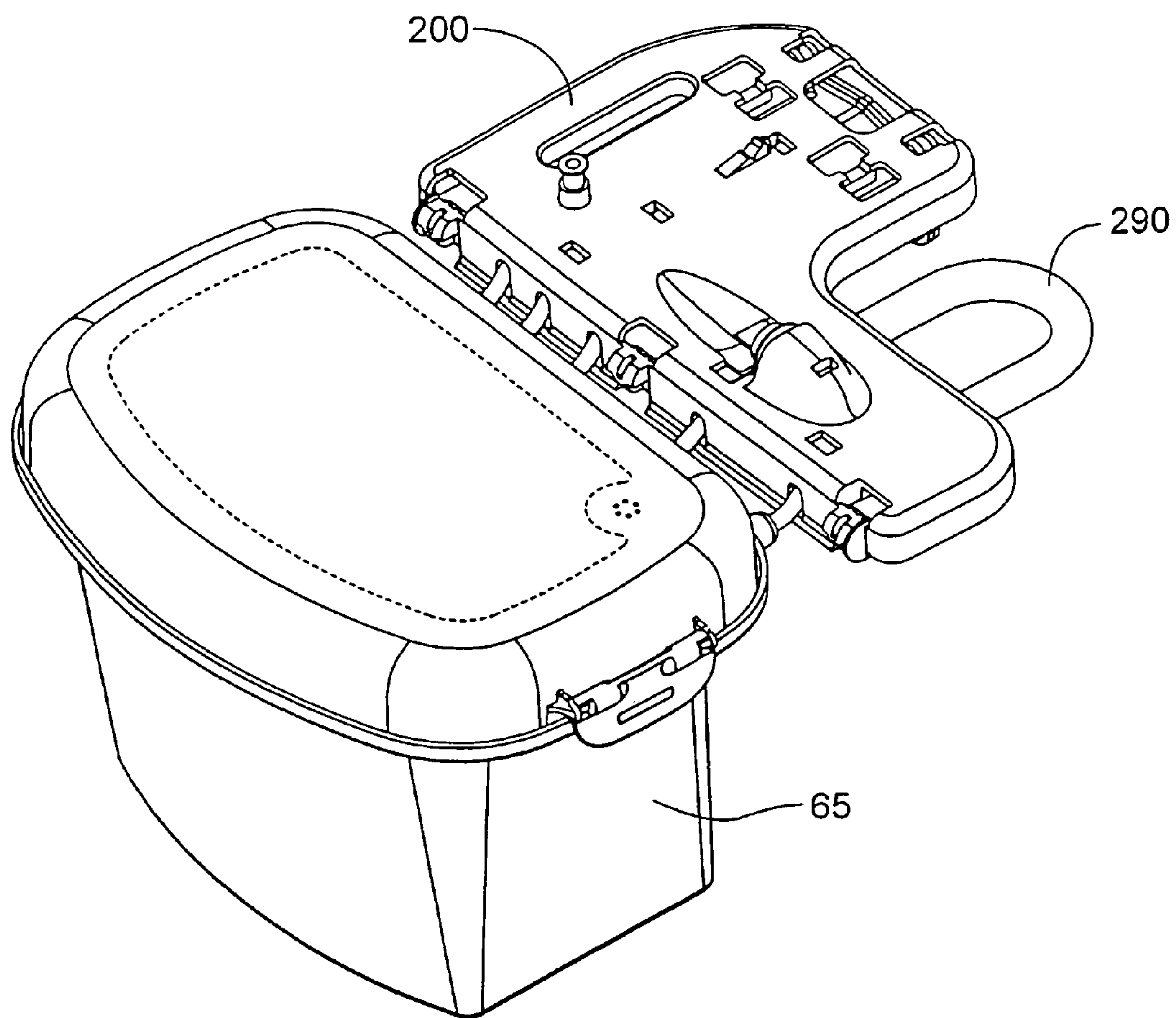

Fig. 12

METHOD AND APPARATUS FOR CONTROLLING AIR PRESSURE IN AN ORGAN OR TISSUE CONTAINER

This application is a continuation of U.S. patent application Ser. No. 10/815,820, filed Apr. 2, 2004, the entire contents of which are hereby incorporated by reference. This non-provisional application also claims the benefit of U.S. Provisional Application No. 60/459,986 filed Apr. 4, 2003.

BACKGROUND OF THE INVENTION

The invention relates to apparatus and methods for perfusing one or more organs, tissues or the like (hereinafter generally referred to as organs) to monitor, sustain and/or restore viability of the organs. This invention further relates to transportation and/or storage of the organs in a housing configured to allow pressure of the housing to be varied.

Preservation of organs by machine perfusion has been accomplished at hypothermic temperatures with or without computer control with crystalloid perfusates and without oxygenation. See, for example, U.S. Pat. Nos. 5,149,321, 5,395,314, 5,584,804, 5,709,654, 5,752,929 and 5,827,222 to Klatz et al., which are hereby incorporated by reference. Hypothermic temperatures provide a decrease in organ metabolism, lower energy requirements, delay depletion of high energy phosphate reserves and accumulation of lactic acid and retard morphological and functional deterioration associated with disruption of blood supply.

Ideally organs would be procured in a manner that limits their warm ischemia time to essentially zero. Unfortunately, in reality, many organs, especially from non-beating heart donors, are procured after extended warm ischemia time periods (i.e., 45 minutes or more). The machine perfusion of these organs at low temperature has demonstrated significant improvement (Transpl Int 1996 Daemen). Further, prior art teaches that the low temperature machine perfusion of organs is preferred at low pressures (Transpl. Int 1996 Yland) with roller or diaphragm pumps delivering the perfusate at a controlled pressure. Numerous control circuits and pumping configurations have been utilized to achieve this objective and to machine perfuse organs in general. See, for example, U.S. Pat. Nos. 5,338,662 and 5,494,822 to Sadri; U.S. Pat. No. 4,745,759 to Bauer et al.; U.S. Pat. Nos. 5,217,860 and 5,472,876 to Fahy et al.; U.S. Pat. No. 5,051,352 to Martindale et al.; U.S. Pat. No. 3,995,444 to Clark et al.; U.S. Pat. No. 4,629,686 to Gruenberg; U.S. Pat. Nos. 3,738,914 and 3,892,628 to Thorne et al.; U.S. Pat. Nos. 5,285,657 and 5,476,763 to Bacchi et al.; U.S. Pat. No. 5,157,930 to McGhee et al.; and U.S. Pat. No. 5,141,847 to Sugimachi et al.

WO 88/05261 to Owen discloses an organ perfusion system including an organ chamber that is supplied with an emulsion fluid or physiological electrolyte that is transported through a perfusion system. The chamber contains a synthetic sac to hold the organ. Perfusate enters the organ through a catheter inserted into an artery. The perfusate is provided by two independent fluid sources, each of which includes two reservoirs.

SUMMARY OF THE INVENTION

The present invention focuses on avoiding damage to an organ during perfusion while monitoring, sustaining and/or restoring the viability of the organ and preserving the organ for storage and/or transport. The invention is directed to appa-

ratus and methods for perfusing an organ to monitor, sustain and/or restore the viability of the organ and/or for transporting and/or storing the organ.

In perfusion, gross organ perfusion pressure may be provided by a pneumatically pressurized medical fluid reservoir controlled in response to a sensor disposed in an end of tubing placed in the organ, which may be used in combination with a stepping motor/cam valve or pinch valve which provides for perfusion pressure fine tuning, prevents over pressurization and/or provides emergency flow cut-off. Alternatively, the organ may be perfused directly from a pump, such as a roller pump or a peristaltic pump, with proper pump control and/or sufficiently fail-safe controllers to prevent over pressurization of the organ, especially as a result of a system malfunction. Substantially eliminating over pressurization prevents and/or reduces damage to the vascular endothelial lining and to the organ tissue in general.

Apparatus of the invention may be used for various organs, such as the kidneys, and may be adapted to more complex organs, such as the liver, having multiple vasculature structures, for example, the hepatic and portal vasculatures of the liver.

An organ diagnostic apparatus may also be provided to produce diagnostic data such as an organ viability index. The organ diagnostic apparatus includes features of an organ perfusion apparatus, such as sensors and temperature controllers, as well as cassette interface features, and provides analysis of input and output fluids in a perfusion system. Typically, the organ diagnostic apparatus is a simplified perfusion apparatus providing diagnostic data in a single pass, in-line perfusion.

Embodiments of the invention also provide an organ cassette which allows an organ to be easily and safely moved between apparatus for perfusing, storing, analyzing and/or transporting the organ. The organ cassette may be configured to provide uninterrupted sterile conditions and efficient heat transfer during transport, recovery, analysis and storage, including transition between the transporter, perfusion apparatus and organ diagnostic apparatus, and/or other apparatus.

Embodiments of this invention also provide an organ transporter which allows for transportation of an organ, particularly over long distances. The organ transporter may include features of an organ perfusion apparatus, such as sensors and temperature controllers, as well as cassette interface features.

Embodiments of this invention provide a pressure control device in the cassette to allow a pressure inside the cassette to be varied.

Embodiments of this invention provide a pressure control valve and/or a closable vent to control the pressure inside the cassette.

Embodiments of this invention provide one or more membranes to allow the pressure inside the cassette to be varied.

Embodiments of the invention provide for one or more of the various types of pressure control devices to be used in conjunction for controlling the pressure inside the cassette.

Embodiments of this invention provide one or more lids with the cassette and the pressure control device(s) are located in the one or more lids.

Embodiments of this invention provide filters associated with the pressure control devices to control the entry of contaminants into the cassette. The pores of the filter can be small enough to prevent bacteria from passing into the cassette.

These and other features and advantages of this invention are described in, or are apparent from, the following detailed description of various exemplary embodiments of systems and methods according to this invention.

BRIEF DESCRIPTION OF THE DRAWINGS

The above and other aspects and advantages of the invention will become apparent from the following detailed

3

description of embodiments when taken in conjunction with the accompanying drawings, in which:

FIG. 1 is an organ perfusion apparatus according to the invention;

FIG. 2 is a schematic diagram of an apparatus of FIG. 1;

FIG. 3 is a diagram of the electronics of the apparatus of FIG. 2;

FIGS. 4A-4D show perspective views of various embodiments of an organ cassette according to the invention;

FIG. 5 is a schematic diagram of an organ perfusion apparatus configured to simultaneously perfuse multiple organs;

FIGS. 6A and 6B show an embodiment of an organ cassette of the present invention;

FIG. 7 shows an exterior perspective view of an organ transporter according to the present invention;

FIG. 8 shows a cross section view of an organ transporter of FIG. 7;

FIG. 9 shows an alternative cross-section view of an organ transporter of FIG. 7;

FIG. 10 shows the mating of a cassette with a compartment according to the present invention;

FIG. 11 shows a tube frame with a tube set according to the present invention; and

FIG. 12 shows a tube frame connected to a cassette according to the present invention.

DETAILED DESCRIPTION OF PREFERRED EMBODIMENTS

For a general understanding of the features of the invention, reference is made to the drawings. In the drawings, like reference numerals have been used throughout to designate like elements.

The invention is described herein largely in the context of apparatus and methods involved in transport, storage, perfusion and diagnosis of tissues and organs. However, the inventive apparatus and methods have many other applications, and thus the various inventive structures, devices, apparatus and methods described herein should not be construed to be limited to, particular contexts of use. Various features of the disclosed invention are particularly suitable for use in the context of, and in conjunction and/or connection with the features of the apparatus and methods disclosed in U.S. patent application Ser. No. 09/645,525, the entire disclosure of which is hereby incorporated by reference herein.

FIG. 1 shows an organ perfusion apparatus 1 according to the invention. FIG. 2 is a schematic illustration of the apparatus of FIG. 1. The apparatus 1 is preferably at least partially microprocessor controlled, and pneumatically actuated. A microprocessor 150 connection to the sensors, valves, thermoelectric units and pumps of the apparatus 1 is schematically shown in FIG. 3. Microprocessor 150 and apparatus 1 may be configured to and are preferably capable of further being connected to a computer network to provide data sharing, for example across a local area network or across the Internet.

The organ perfusion apparatus 1 is preferably capable of perfusing one or more organs simultaneously, at both normothermic and hypothermic temperatures (hereinafter, normothermic and hypothermic perfusion modes). All medical fluid contact surfaces are preferably formed of or coated with materials compatible with the medical fluid used, more preferably non-thrombogenic materials. As shown in FIG. 1, the apparatus 1 may include a housing 2 which includes front cover 4, which is preferably translucent, and a reservoir

4

access door 3. The apparatus preferably has one or more control and display areas 5a, 5b, 5c, 5d for monitoring and controlling perfusion.

As schematically shown in FIG. 2, enclosed within the housing 2 is a reservoir 10 which preferably includes three reservoir tanks 15a, 15b, 17. Two of the reservoir tanks 15a, 15b are preferably standard one liter infusion bags, each with a respective pressure cuff 16a, 16b. A pressure source 20 can be provided for pressurizing the pressure cuffs 16a, 16b. The pressure source 20 is preferably pneumatic and may be an on board compressor unit 21 supplying at least 10 LPM external cuff activation via gas tubes 26, 26a, 26b, as shown in FIG. 2. The invention, however, is not limited to use of an on board compressor unit as any adequate pressure source can be employed, for example, a compressed gas (e.g., air, CO₂, oxygen, nitrogen, etc.) tank (not shown) preferably with a tank volume of 1.5 liters at 100 psi or greater for internal pressurization. Alternatively, an internally pressurized reservoir tank (not shown) may be used. Reservoir tanks 15a, 15b, 17 may, in embodiments, be bottles or other suitably rigid reservoirs that can supply perfusate by gravity or can be pressurized by compressed gas.

Gas valves 22-23 may be provided on the gas tube 26 to allow for control of the pressure provided by the onboard compressor unit 21. Anti-back flow valves 24a, 24b may be provided respectively on the gas tubes 26a, 26b. Pressure sensors P5, P6 may be provided respectively on the gas tubes 26a, 26b to relay conditions therein to the microprocessor 150, shown in FIG. 3. Perfusion, diagnostic and/or transporter apparatus may be provided with sensors to monitor perfusion fluid pressure and flow in the particular apparatus to detect faults in the particular apparatus, such as pressure elevated above a suitable level for maintenance of the organ. Gas valves GV₁ and GV₂ may be provided to release pressure from the cuffs 16a, 16b. One or both of gas valves GV₁ and GV₂ may be vented to the atmosphere. Gas valve GV₄ in communication with reservoir tanks 15a, 15b via tubing 18a, 18b may be provided to vent air from the reservoir tanks 15a, 15b through tubing 18. Tubing 18, 18a, 18b, 26, 26a and/or 26b may be configured with filters and/or check valves to prevent biological materials from entering the tubing or from proceeding further along the fluid path. The check valves and/or filters may be used to prevent biological materials from leaving one organ perfusion tubeset and being transferred to the tubeset of a subsequent organ in a multiple organ perfusion configuration. The check valves and/or filters may also be used to prevent biological materials, such as bacteria and viruses, from being transferred from organ to organ in subsequent uses of the perfusion apparatus in the event that such biological materials remain in the perfusion apparatus after use. The check valves and/or filters may be provided to prevent contamination problems associated with reflux in the gas and/or vent lines. For example, the valves may be configured as anti-reflux valves to prevent reflux. The third reservoir tank 17 is preferably pressurized by pressure released from one of the pressure cuffs via gas valve GV₂.

The medical fluid may be blood or a synthetic fluid and may, for example, be a simple crystalloid solution, or may be augmented with an appropriate oxygen carrier. The oxygen carrier may, for example, be washed, stabilized red blood cells, cross-linked hemoglobin, pegolated hemoglobin or fluorocarbon based emulsions. The medical fluid may also contain antioxidants known to reduce peroxidation or free radical damage in the physiological environment and specific agents known to aid in tissue protection. An oxygenated (e.g., cross-linked hemoglobin-based bicarbonate) solution is preferred for a normothermic mode while a non-oxygenated

(e.g., simple crystalloid solution preferably augmented with antioxidants) solution is preferred for a hypothermic mode. The specific medical fluids used in both the normothermic and hypothermic modes may be designed or selected to reduce or prevent the washing away of or damage to the vascular endothelial lining of the organ. For a hypothermic perfusion mode, as well as for flush and/or static storage, a preferred solution is the solution disclosed in U.S. Pat. No. 6,492,103, the entire disclosure of which is incorporated herein by reference. Examples of additives which may be used in perfusion solutions for the present invention are also disclosed in U.S. Pat. No. 6,046,046 to Hassanein, the entire disclosure of which is incorporated by reference. Of course, other suitable solutions and materials may be used, as is known in the art.

The medical fluid within reservoir **10** is preferably brought to a predetermined temperature by a first thermoelectric unit **30a** in heat transfer communication with the reservoir **10**. A temperature sensor **T3** relays the temperature within the reservoir **10** to the microprocessor **150**, which adjusts the thermoelectric unit **30a** to maintain a desired temperature within the reservoir **10** and/or displays the temperature on a control and display areas **5a** for manual adjustment. Alternatively or in addition, and preferably where the organ perfusion device is going to be transported, the medical fluid within the hypothermic perfusion fluid reservoir can be cooled utilizing a cryogenic fluid heat exchanger apparatus such as that disclosed in filed U.S. Pat. No. 6,014,864, which is hereby incorporated by reference.

An organ chamber **40** is provided which supports a cassette **65**, as shown in FIG. 2, which holds an organ to be perfused, or a plurality of cassettes **65**, as shown in FIG. 5, preferably disposed one adjacent the other. Various embodiments of the cassette **65** are shown in FIGS. 4A-4D. The cassette **65** is preferably formed of a material that is light but durable so that the cassette **65** is highly portable. The material may also be transparent to allow visual inspection of the organ.

FIG. 4A shows a cassette **65** which holds an organ **60** to be perfused. Various embodiments of such a cassette **65** are shown in FIGS. 4A-4D, 6A, 6B, 10 and 12. The cassette **65** is preferably formed of a material that is light but durable so that the cassette **65** is highly portable. The material may also be transparent to allow visual inspection of the organ.

Preferably the cassette **65** includes side walls **67a**, a bottom wall **67b** and an organ supporting surface **66**, which is preferably formed of a porous, perforated or mesh material to allow fluids to pass there through. The cassette **65** may also include a top **67d** and may be provided with an opening(s) **63** for tubing (see, for example, FIG. 4D). The opening(s) **63** may include seals **63a** (e.g., septum seals or o-ring seals) and optionally be provided with plugs (not shown) to prevent contamination of the organ and maintain a sterile environment. Additionally, the cassette **65** may be provided with tubing for connection to an organ and/or to remove medical fluid from the organ bath, and a connection device(s) **64** for connecting the tubing to, for example, tubing **50c**, **81**, **82**, **91** and/or **132**, (see, for example, FIG. 4D) of an organ storage, transporter, perfusion and/or diagnostic apparatus.

The cassette **65**, and/or the organ support, opening(s), tubing(s) and/or connections(s), may be specifically tailored to the type of organ and/or size of organ to be perfused. Flanges **67c** of the side support walls **67a** can be used to support the cassette **65** disposed in an organ storage, transporter, perfusion and/or diagnostic apparatus. The cassette **65** may further include a handle **68** which allows the cassette **65** to be easily handled, as shown, for example, in FIGS. 4C and 4D. Each cassette **65** may also be provided with its own mechanism

(e.g., stepping motor/cam valve **75** (for example, in the handle portion **68**, as shown in FIG. 4C)) for fine tuning the pressure of medical fluid perfused into the organ **60** disposed therein, as discussed in more detail below. Alternatively, pressure may, in embodiments, be controlled by way of a pneumatic chamber, such as an individual pneumatic chamber for each organ (not shown), or by any suitable variable valve such as a rotary screw valve or a helical screw valve.

Cassette **65** may be provided with a closeable and/or filtered vent **61** (see, for example, FIG. 4D). Vent **61** preferably includes a filter device, and provides for control and/or equalization of pressure within the cassette without contamination of the contents of the cassette. For example, organs are frequently transported by aircraft, in which pressure changes are the norm. Even ground transportation can involve pressure changes as motor vehicles pass through tunnels, over mountains, etc. It is often desirable to provide for pressure equalization of the cassette under such circumstances. However, free flow of air to achieve pressure equalization might introduce contaminants into the cassette. Thus, a filtering vent **61** is preferably provided to allow the air flow without permitting introduction of contaminants into the cassette.

The filter preferably will let clean air pass in both directions but will not allow dirt, dust, liquids and other contaminants to pass. The pore size in the filters can be any size desired and can be small enough to prevent bacteria from passing. A pressure control valve can optionally be associated with vent **61** as well. Such a valve may be configured or controlled to restrict the rate at which external pressure changes are transmitted to the inside of the cassette, or even to prevent pressure increases and/or decreases, as desired.

FIGS. 6A-6B show an alternative embodiment of cassette **65**. The cassette **65** is a portable device and is provided with a lid, preferably two lids, an inner lid **410** and an outer lid **420**. As such, the one or more lids **410** and **420** can create a substantially airtight seal with the cassette **65**. This air tight seal can create a pressure difference between the inside and outside of cassette **65**. Pressure sensors that control perfusion of the organ may be referenced to the atmospheric pressure. In such embodiments, it is desirable that the air space around the organ in cassette **65** is maintained at atmospheric pressure.

Accordingly, the cassette may also include one or more devices for controlling the pressure. The devices for controlling pressure can be an active or passive device such as a valve or membrane. Membranes **415** and **425**, for example, can be located in the inner lid **410** and outer lid **420**, respectively. It should be appreciated that any number of membranes can be located in the cassette (including its lid(s)) without departing from the spirit and scope of the invention. The membranes **415** and **425** are preferably hydrophobic membranes which help maintain an equal pressure between the inside and the outside of the cassette. A pressure control valve can optionally be associated with membranes **415** and **425**. Such a pressure control valve may be configured or controlled to restrict the rate at which external pressure changes are transmitted to the inside of the cassette, or even to prevent pressure increases and/or decreases, as desired.

The membranes **415** and **425**, if sufficiently flexible, can be impermeable or substantially impermeable. Alternatively, they may include filters that will let clean air pass in both directions, however, the membranes **415** and **425** will not allow dirt, dust, liquids and other contaminants to pass. The pore size in the filters can be any size desired, and preferably, the pore size of the membranes **415** and **425** can be small enough to prevent bacteria from passing. The actions of the membranes **415** and **425** and corresponding filters help maintain the sterility of the system.

Preferably, cassette **65** is made of a sufficiently durable material that it can withstand penetration and harsh impact. The lids **410** and **420** may be removable or may be hinged or otherwise connected to the body of cassette **65**. Clasp **405**, for example, may provide a mechanism to secure lids **410** and **420** to the top of cassette **65**. Clasp **405** may additionally be configured with a lock to provide further security and stability. A biopsy and/or venting port **430** may additionally be included in inner lid **410** or both inner lid **410** and outer lid **420**. Port **430** may provide access to the organ to allow for additional diagnosis of the organ with minimal disturbance of the organ. Cassette **65** may also have an overflow trough **440** (shown in FIG. **6B** as a channel present in the top of cassette **65**). When lids **410** and **420** are secured on cassette **65**, overflow trough **440** provides a region that is easy to check to determine if the inner seal is leaking. Perfusate may be poured into and out of cassette **65** and may be drained from cassette **65** through a stopcock or removable plug.

In FIG. **6A**, cassette **65** is shown with tubeset **400**. Tubeset **400** can be connected to perfusion apparatus **1** or to an organ transporter or an organ diagnostic apparatus, and allows cassette **65** to be moved between various apparatus without jeopardizing the sterility of the interior of cassette **65**. Preferably, cassette **65** is made of a sufficiently durable material that it can withstand penetration and harsh impact. As shown in FIG. **6A**, the tube set may be connected to a bubble trap device BT. A preferred such device is described in detail in a U.S. provisional patent application filed simultaneously herewith entitled "Device for separating bubbles from a liquid path" Ser. No. 10/816,252.

Cassette **65** and/or its lid(s) may be constructed of an optically transparent material to allow for viewing of the interior of cassette **65** and monitoring of the organ and to allow for video images or photographs to be taken of the organ. A perfusion apparatus or cassette **65** may be wired and fitted with a video camera or a photographic camera, digital or otherwise, to record the progress and status of the organ. Captured images may be made available over a computer network such as a local area network or the internet to provide for additional data analysis and remote monitoring. Cassette **65** may also be provided with a tag that would signal, e.g., through a bar code, magnetism, radio frequency, or other means, the location of the cassette, that the cassette is in the apparatus, and/or the identity of the organ to perfusion, storage, diagnostic and/or transport apparatus. Cassette **65** may be sterile packaged and/or may be packaged or sold as a single-use disposable cassette, such as in a peel-open pouch. A single-use package containing cassette **65** may also include tubeset **400** and/or tube frame **200**, discussed further below.

Cassette **65** is preferably configured such that it may be removed from an organ perfusion apparatus and transported to another organ perfusion and/or diagnostic apparatus in a portable transporter apparatus as described herein or, for example, a conventional cooler or a portable container such as that disclosed in U.S. Pat. No. 6,209,343, or U.S. Pat. No. 5,586,438 to Fahy, both of which are hereby incorporated by reference in their entirety.

In various exemplary embodiments according to this invention, when transported, the organ may be disposed on the organ supporting surface **66** and the cassette **65** may be enclosed in a preferably sterile bag **69**, as shown, for example, in FIG. **4A**. When the organ is perfused with medical fluid, effluent medical fluid collects in the bag **69** to form an organ bath. Alternatively, cassette **65** can be formed with a fluid tight lower portion in which effluent medical fluid may collect, or effluent medical fluid may collect in another compartment of an organ storage, transporter, perfusion and/or diag-

nostic apparatus, to form an organ bath. In either case, the bag **69** would preferably be removed prior to inserting the cassette into an organ storage, transporter, perfusion and/or diagnostic apparatus. Further, where a plurality of organs are to be perfused, multiple organ compartments may be provided. Alternatively, cassette **65** can be transported in the cassette and additionally carried within a portable organ transporter.

FIG. **7** shows an external view of an embodiment of a transporter **1900** of the invention. The transporter **1900** of FIG. **7** has a stable base to facilitate an upright position and handles **1910** for carrying transporter **1900**. Transporter **1900** may also be fitted with a shoulder strap and/or wheels to assist in carrying transporter **1900**. A control panel **1920** is preferably also provided. Control panel **1920** may display characteristics, such as, but not limited to, infusion pressure, attachment of the tube frame, power on/off, error or fault conditions, flow rate, flow resistance, infusion temperature, bath temperature, pumping time, battery charge, temperature profile (maximums and minimums), cover open or closed, history log or graph, and additional status details and messages, some or all of which are preferably further transmittable to a remote location for data storage and/or analysis. Flow and pressure sensors or transducers in transporter **1900** may be provided to calculate various organ characteristics including pump pressure and vascular resistance of an organ, which can be stored in computer memory to allow for analysis of, for example, vascular resistance history, as well as to detect faults in the apparatus, such as elevated pressure.

Transporter **1900** preferably has latches **1930** that require positive user action to open, thus avoiding the possibility that transporter **1900** inadvertently opens during transport. Latches **1930** hold top **1940** in place on transporter **1900** in FIG. **7**. Top **1940** or a portion thereof may be constructed with an optically transparent material to provide for viewing of the cassette and organ perfusion status. Transporter **1900** may be configured with a cover open detector that monitors and displays whether the cover is open or closed. Transporter **1900** may be configured with an insulating exterior of various thicknesses to allow the user to configure or select transporter **1900** for varying extents and distances of transport. In embodiments, compartment **1950** may be provided to hold patient and organ data such as charts, testing supplies, additional batteries, hand-held computing devices and/or configured with means for displaying a UNOS label and/or identification and return shipping information.

FIG. **8** shows a cross-section view of a transporter **1900**. Transporter **1900** contains cassette **65** and pump **2010**. Cassette **65** may preferably be placed into or taken out of transporter **1900** without disconnecting tubeset **400** from cassette **65**, thus maintaining sterility of the organ. In embodiments, sensors in transporter **1900** can detect the presence of cassette **65** in transporter **1900**, and depending on the sensor, can read the organ identity from a barcode or radio frequency or other "smart" tag that may be attached or integral to cassette **65**. This can allow for automated identification and tracking of the organ and helps monitor and control the chain of custody. A global positioning system may be added to transporter **1900** and/or cassette **65** to facilitate tracking of the organ. Transporter **1900** may be interfaceable to a computer network by hardware connection to a local area network or by wireless communication while in transit. This interface may allow data such as perfusion parameters, vascular resistance, and organ identification and transporter and cassette location to be tracked and displayed in real-time or captured for future analysis.

Transporter **1900** also preferably contains a filter **2020** to remove sediment and other particulate matter, preferably

ranging in size from 0.05 to 15 microns in diameter or larger, from the perfusate to prevent clogging of the apparatus or the organ. Transporter **1900** preferably also contains batteries **2030**, which may be located at the bottom of transporter **1900** or beneath pump **2010** or at any other location but preferably one that provides easy access to change batteries **2030**. Batteries **2030** may be rechargeable outside of transporter **1900** or while within transporter **1900** and/or are preferably hot-swappable one at a time. Batteries **2030** are preferably rechargeable rapidly and without full discharge. Transporter **1900** may also provide an additional storage space **2040**, for example, at the bottom of transporter **1900**, for power cords, batteries and other accessories. Transporter **1900** may also include a power port for a DC hookup, e.g., to a vehicle such as an automobile or airplane, and/or for an AC hookup.

As shown in FIG. **8**, the cassette wall CW is preferably configured to mate with a corresponding configuration of inner transporter wall TW to maximize contact, and thus heat transfer, there between as discussed in more detail below.

FIG. **9** shows an alternative cross-section of transporter **1900**. In FIG. **9**, the transporter **1900** may have an outer enclosure **2310** which may, for example, be constructed of metal, or preferably a plastic or synthetic resin that is sufficiently strong to withstand penetration and impact. Transporter **1900** contains insulation **2320**, preferably a thermal insulation made of, for example, glass wool or expanded polystyrene. Insulation **2320** may be various thicknesses ranging from 0.5 inches to 5 inches thick or more, preferably 1 to 3 inches, such as approximately 2 inches thick. Transporter **1900** may be cooled by coolant **2110**, which may be, e.g., an ice and water bath or a cryogenic material. In embodiments using cryogenic materials, the design should be such that organ freezing is prevented. An ice and water mixture is preferably an initial mixture of approximately 1 to 1, however, in embodiments the ice and water bath may be frozen solid. Transporter **1900** can be configured to hold various amounts of coolant, preferably up to 10 to 12 liters. An ice and water bath is preferable because it is inexpensive and generally can not get cold enough to freeze the organ. Coolant **2110** preferably lasts for a minimum of 6 to 12 hours and more preferably lasts for a minimum of 30 to 50 hours without changing coolant **2110**. The level of coolant **2110** may, for example, be viewed through a transparent region of transporter **1900** or be automatically detected and monitored by a sensor. Coolant **2110** can preferably be replaced without stopping perfusion or removing cassette **65** from transporter **1900**. Coolant **2110** is preferably maintained in a watertight compartment **2115** of transporter **1900**. For example, an inner transporter wall TW as shown in FIG. **8** can be interposed between the coolant **2110** and cassette wall (CW) in the apparatus of FIG. **9**. Compartment **2115** preferably prevents the loss of coolant **2110** in the event transporter **1900** is tipped or inverted. Heat is conducted from the walls of the perfusate reservoir/cassette **65** into coolant **2110** enabling control within the desired temperature range. Coolant **2110** is a failsafe cooling mechanism because transporter **1900** automatically reverts to cold storage in the case of power loss or electrical or computer malfunction. Transporter **1900** may also be configured with a heater to raise the temperature of the perfusate.

Transporter **1900** may be powered by batteries or by electric power provided through plug **2330**. An electronics module **2335** may also be provided in transporter **1900**. Electronics module **2335** may be cooled by vented air convection **2370**, and may further be cooled by a fan. Preferably, electronic module **2335** is positioned separate from the perfusion tubes to prevent the perfusate from wetting electronics mod-

ule **2335** and to avoid adding extraneous heat from electronics module **2335** to the perfusate. Transporter **1900** preferably has a pump **2010** that provides pressure to perfusate tubing **2360** (e.g. of tube set **400**) to deliver perfusate **2340** to organ **2350**. Transporter **1900** may be used to perfuse various organs such as a kidney, heart, liver, small intestine and lung. Transporter **1900** and cassette **65** may accommodate various amounts to perfusate **2340**, for example up to 3 to 5 liters. Preferably, approximately 1 liter of a hypothermic perfusate **2340** is used to perfuse organ **2350**.

Cassette **65** and transporter **1900** are preferably constructed to fit or mate such that efficient heat transfer is enabled. Preferably, the transporter **1900** contains a compartment **2115** for receiving the cassette. The transporter **1900** preferably relies on conduction to move heat from the cassette **65** to coolant **2110** contained in compartment **2115**. This movement of heat allows the transporter **1900** to maintain a desired temperature of the perfusion solution. The geometric elements of cassette **65** and transporter **1900** are preferably constructed such that when cassette **65** is placed within transporter **1900**, the contact area between cassette **65** and transporter **1900** is as large as possible and they are secured for transport.

FIG. **10** shows an example of this geometry between cassette **65** and compartment **2115** containing coolant **2110**. The interface geometry between cassette **65** and compartment **2115** is preferably designed so that cassette **65** will wedge into a cavity created by compartment **2115**. Accordingly, the angles of the side walls are substantially equal and thus, all side walls of cassette **65** make contact with the side walls of compartment **2115** regardless of the shape of the cassette sides or compartment sides, such as flat or curved. Having the included angles substantially equal allows the surfaces of cassette **65** and the compartment **2115** to make contact even when influenced by the thermal expansion and contraction of the walls and mechanical tolerances.

The height of cassette **65** above compartment **2115** is determined by the mating surfaces of cassette **65** and compartment **2115**. As shown in FIG. **10** the bottom of the cassette does not have to rest on the bottom of compartment **2115**, but can rest at the bottom in embodiments in which the shape of cassette **65** and compartment **2115** allow it. It should be appreciated that the shape of cassette **65** and compartment **2115** in these embodiments can be any shape, such as for example a truncated cone, that allows for maximum contact and therefore maximum heat transfer between them.

As discussed above, heat is conducted from the walls of the perfusate reservoir/cassette **65** into coolant **2110** of compartment **2115** enabling control within the desired temperature range. Coolant **2110** can provide a failsafe cooling mechanism because transporter **1900** automatically reverts to cold storage in the case of power loss or electrical or computer malfunction. Transporter **1900** may also be configured with a heater to raise the temperature of the perfusate.

FIG. **11** shows a tube frame **200** of embodiments of the invention, which may be used for holding tube set **400** discussed with respect to FIG. **6A**. Tube frame **200** is preferably formed of a material that is light but durable, such as for example plastic, so that tube frame **200** is highly portable. The tube frame **200** is designed to hold the tubing of the tube set **400** in desired positions. In FIG. **11**, tube frame **200** is shown holding the tubes of tube set **400** of FIG. **6A**. It should be appreciated that there may be other numbers of tubes that comprise tube set **400**. Having the tubing in set positions allows for easier installation and connection with devices

11

such as cassette **65** as shown in FIG. **12**. The cassette **65** and tube frame **200** are then preferably mated with transporter **1900**.

When tube frame **200** is mated with cassette **65**, the tube set **400** is preferably already connected with the cassette **65**. For example, tube **270** provides an inlet to a pump **2010** from the stored liquid at the bottom of cassette **65**. The liquid travels through tube **290** and back out outlet **280** through a filter which may, for example, be located inside or outside, for example, below, cassette **65**. After traveling through the filter, the liquid will travel to tube **240** and into the bubble trap **210**. A sample port **295** may be provided with tube frame **200** to allow for drawing liquid out of or injecting liquid into the tube **240**. Liquid travels into the bubble trap **210** in tube **240** and travels out of bubble trap **210** in tube **260**, which carries the liquid into the cassette, for example, to infuse and/or wash the organ. Tube **250** will carry liquid or gas leaving the bubble trap **210** into cassette **65** bypassing infusion of, but optionally washing, the organ.

It should be appreciated that tube frame **200** can hold other devices in addition to tubes. For example, tube frame **200** can hold a bubble trap device **210** and a pressure sensor **220** used to control pump **2010**. It should also be appreciated that tube frame **200** and tube set **400** can be connected to a variety of devices such as the organ perfusion device **1** or an organ diagnostic device, as well as a cassette and/or transporter.

In various exemplary embodiments, tube frame **200** is preferably attachable to a portion of the transporter **1900**. The tube frame **200** may be connected to transporter **1900**, and other devices, by way of snaps **230** or other structure that will securely hold the tube frame to the device. Sensors, for example mechanical or electrical sensors, in transporter **1900**, or other devices, can be provided to detect the presence of tube frame **200** in transporter **1900**. If the tube frame **200** is not properly attached to the transporter, the sensors may be configured to send an appropriate alert message to control panel **1920** for notifying the user of a problem. If no action is taken to properly attach tube frame **200** in a given amount of time automatically set or programmed by the user, transporter **1900** can be programmed to prevent the beginning of perfusion. It should be appreciated that if perfusion has begun and tube frame **200** is not appropriately set, the transporter can be programmed to stop perfusion.

Another valuable feature of the tube frame is that makes the stationary surface for the tube **250**, and tube **260**. These tubes are used to route perfusion solution either directly to the organ or, bypassing the organ, into the reservoir. It is desirable to have tube **250** and tube **260** located in a relatively fixed position so that the routing may be done by pinching the tubing so that no liquid can pass. The tubes may, for example, be pinched by a solenoid (not shown) located on transporter **1900** that drives a blade that pinches tube **250** and/or tube **260** against the tube frame **200**.

While the invention has been described in conjunction with specific embodiments thereof, it is evident that many alternatives, modifications and variations may be apparent to those skilled in the art. Accordingly, the embodiments of the invention as set forth herein are intended to be illustrative, not limiting. Various changes may be made without departing from the spirit and scope of the invention.

What is claimed is:

1. An apparatus for holding an organ or tissue for at least one of perfusion, storage, diagnosis and transport of the organ, comprising:

an organ cassette for holding the organ, the organ cassette including a wall that at least partially delimits a volume for holding the organ;

12

a plurality of lids that form at least one substantially airtight seal with the organ cassette, at least one lid being configured to open separately from at least one other of the plurality of lids; and

an organ or tissue supporting surface configured to support the organ or tissue within the organ cassette while allowing effluent medical fluid to pass through the organ or tissue,

wherein the organ cassette is configured to be received by at least one of a perfusion device, a portable perfusion device and a diagnostic device, and

wherein at least two of the lids each includes at least one pressure control device that controls pressure within the organ cassette and the at least two lids are configured to each individually form a substantially airtight seal with the wall by coming into sealing contact with the wall.

2. The apparatus of claim **1**, wherein the at least one pressure control device controls the pressure to be at a desired pressure.

3. The apparatus of claim **2**, wherein the desired pressure is atmospheric pressure.

4. The apparatus of claim **1**, wherein the organ cassette includes more than two pressure control devices.

5. The apparatus of claim **1**, wherein the at least one pressure control device is at least one of a closable vent, a pressure control valve that controls the pressure within the organ cassette, and a membrane.

6. The apparatus of claim **5**, wherein the at least one pressure control device includes a filter.

7. An apparatus for holding an organ or tissue for at least one of perfusion, storage, diagnosis and transport of the organ, comprising:

an organ cassette for holding the organ, the organ cassette including a wall that at least partially delimits a volume for holding the organ;

a plurality of lids that each form at least one substantially airtight seal with the organ cassette by coming into sealing contact with the wall, at least one lid being configured to open separately from at least one other of the plurality of lids; and

an organ or tissue supporting surface configured to support the organ or tissue within the organ cassette while allowing effluent medical fluid to pass through the organ or tissue,

wherein the organ cassette is configured to be received by at least one of a perfusion device, a portable perfusion device and a diagnostic device,

wherein at least one of the lids includes at least one pressure control device that controls pressure within the organ cassette, and

wherein the at least one pressure control device is a membrane.

8. The apparatus of claim **7**, wherein one of the lids includes two pressure control devices.

9. The apparatus of claim **8**, wherein the pressure control devices also include at least one of a closable vent and a pressure control valve.

10. The apparatus of claim **7**, wherein at least two of the lids each includes a pressure control device.

11. The apparatus of claim **7**, wherein the pressure control device controls pressure to be at a desired pressure.

12. The apparatus of claim **11**, wherein the desired pressure is atmospheric pressure.

13. The apparatus of claim **7**, wherein the membrane is a hydrophobic membrane.

13

14. The apparatus of claim 7, wherein pores of the membrane are small enough to prevent bacteria from entering the organ cassette.

15. The apparatus of claim 7, wherein the membrane is substantially impermeable to liquid.

16. A method of at least two of perfusion, storage, and transport of an organ or tissue, comprising:

placing the organ or tissue in an organ cassette that is configured to be received by at least two of a perfusion device, a portable perfusion device and a diagnostic device, the organ cassette including:

a wall that at least partially delimits a volume for holding the organ, and

a plurality of lids that form at least one substantially airtight seal with the wall; and

separately opening or closing at least one of the plurality of lids without opening or closing at least one other of the plurality of lids,

wherein at least two of the lids each includes at least one pressure control device that controls pressure within the organ cassette and the at least two lids are configured to each individually form a substantially airtight seal with the wall by coming into sealing contact with the wall.

17. The method of claim 16, wherein the at least one pressure control device controls pressure to be at a desired pressure.

18. The method of claim 17, wherein the desired pressure is atmospheric pressure.

19. The method of claim 16, wherein the pressure control device is at least one of a closable vent, a pressure control valve and a membrane that is substantially impermeable to at least liquid.

20. The method of claim 19, wherein the membrane is a hydrophobic membrane.

21. The method of claim 20, wherein the pressure control device includes a filter that prevents at least one contaminant from entering the organ cassette.

22. The method of claim 16, further comprising:

placing the organ cassette containing the organ or tissue in the portable perfusion device, without removal of the organ or tissue from the organ cassette; and

transporting the organ or tissue in the organ cassette in the portable perfusion device.

23. The method of claim 16, further comprising:

placing the organ or tissue on an organ supporting surface within the organ cassette that is configured to support the organ or tissue within the organ cassette while allowing effluent medical fluid to pass through the organ or tissue.

24. The method of claim 23, the method further comprising:

maintaining the effluent medical fluid at a desired pressure.

25. The method of claim 24, wherein the desired pressure is atmospheric pressure.

26. The method of claim 24, wherein the desired pressure is maintained by a pressure sensor.

27. A method of at least two of perfusion, storage, and transport of an organ or tissue, comprising:

placing the organ or tissue in an organ cassette that is configured to be received by at least one of a perfusion

14

device, a portable perfusion device and a diagnostic device, the organ cassette including:

a wall that at least partially delimits a volume for holding the organ, and

a plurality of lids that form at least one airtight seal with the wall, wherein at least two of the plurality of lids are configured to each individually form an airtight seal with the wall by coming into sealing contact with the wall;

separately opening or closing at least one of the plurality of lids without opening or closing at least one other of the plurality of lids; and

controlling the pressure within the organ cassette by at least one pressure control device,

wherein at least one of the lids includes the at least one pressure control device.

28. The method of claim 27, wherein the at least one pressure control device is at least one of a closable vent, a pressure control valve and a membrane that is substantially impermeable to at least liquid.

29. The method of claim 28, wherein at least two of the lids each includes two pressure control devices.

30. The method of claim 28, wherein at least two of the lids each includes a pressure control device.

31. The method of claim 28, wherein the membrane is a hydrophobic membrane.

32. The method of claim 27, wherein controlling the pressure includes maintaining pressure of the organ cassette at a desired pressure.

33. The method of claim 32, wherein the desired pressure is atmospheric pressure.

34. The method of claim 27, wherein the pressure control device includes a filter that prevents at least one contaminant from entering the organ cassette.

35. The method of claim 27, wherein the organ cassette includes an organ or tissue supporting surface configured to support the organ or tissue, the method further comprising:

placing the organ or tissue supporting surface supporting the organ or tissue in an organ perfusion apparatus; and perfusing the organ or tissue in the organ cassette in the organ perfusion apparatus.

36. The method of claim 27, further comprising:

placing the organ cassette containing the organ or tissue in at least one of the portable perfusion device and the perfusion device, without removal of the organ or tissue from the organ cassette.

37. The method of claim 36, further comprising:

placing the organ cassette containing the organ or tissue in the portable perfusion device; and

transporting the organ or tissue in the organ cassette in the portable perfusion device, without removal of the organ or tissue from the organ cassette.

38. The method of claim 27, further comprising controlling a pressure inside the organ cassette so that the pressure inside the organ cassette is substantially equal to a pressure outside the organ cassette.