

US008364769B2

(12) **United States Patent**
McCarthy et al.

(10) **Patent No.:** **US 8,364,769 B2**
(45) **Date of Patent:** ***Jan. 29, 2013**

(54) **COMMUNICATIONS SYSTEM PROVIDING MESSAGE AGGREGATION FEATURES AND RELATED METHODS**

455/8, 10, 12.1, 13.1, 13.3, 67.3, 429, 522, 455/412.2, 466; 715/57, 752
See application file for complete search history.

(75) Inventors: **Steven J. McCarthy**, Bellevue, WA (US); **Darren L. Gardner**, Issaquah, WA (US); **Michael Jack Zakharoff**, Sumner, WA (US)

(56) **References Cited**

(73) Assignee: **Teamon Systems, Inc.**, Wilmington, DE (US)

U.S. PATENT DOCUMENTS

(*) Notice: Subject to any disclaimer, the term of this patent is extended or adjusted under 35 U.S.C. 154(b) by 42 days.

This patent is subject to a terminal disclaimer.

5,802,292	A	9/1998	Mogul	395/200.33
5,805,298	A	9/1998	Ho et al.	358/402
5,822,523	A	10/1998	Rothschild et al.	709/236
5,920,803	A *	7/1999	Taylor	455/12.1
5,937,162	A	8/1999	Funk et al.	709/206
5,995,503	A	11/1999	Crawley et al.	370/351

(Continued)

FOREIGN PATENT DOCUMENTS

EP 0491367 6/1992

OTHER PUBLICATIONS

“Fetchmail”, <http://fetchmail.berlios.de/>, Jul. 2, 2009.

(21) Appl. No.: **12/728,364**

(22) Filed: **Mar. 22, 2010**

(65) **Prior Publication Data**

US 2010/0179999 A1 Jul. 15, 2010

Related U.S. Application Data

(63) Continuation of application No. 11/459,227, filed on Jul. 21, 2006, now Pat. No. 7,689,656, which is a continuation of application No. 10/779,350, filed on Feb. 13, 2004, now Pat. No. 7,111,047.

(60) Provisional application No. 60/493,763, filed on Aug. 8, 2003.

(51) **Int. Cl.**
G06F 15/16 (2006.01)

(52) **U.S. Cl.** **709/206**; 709/201; 709/202; 709/203; 709/204; 709/205; 709/207; 709/217; 709/218; 709/219; 709/230; 709/232; 709/238; 709/249; 370/349; 370/351; 370/389; 370/395.21; 370/450; 370/471; 370/473; 370/474; 455/412.2; 455/466; 715/752

(58) **Field of Classification Search** 709/206, 709/207, 217, 219, 230, 249, 201, 202, 203, 709/204, 205, 218, 232, 238; 370/450, 349, 370/351, 389, 395.21, 471, 473, 474; 455/3,

(Continued)

Primary Examiner — John Follansbee
Assistant Examiner — Saket K. Daftuar

(74) *Attorney, Agent, or Firm* — Allen, Dyer, Doppelt, Milbrath & Gilchrist, P.A.

(57) **ABSTRACT**

A communications system may include a plurality of source message servers for storing messages for delivery to a user, a target message server having a target message box associated therewith, and an aggregation server for periodically aggregating the messages from the source message servers to the target message box for retrieval by the user. The target message server may provide a delivery failure message to the aggregation server based upon a failure to deliver a message to the target message box. As such, the aggregation server may increase a period of sending messages to the target message box based upon a delivery failure message therefrom, and thereafter decrease the period of sending messages to the target message box based upon a successful delivery of a message thereto.

15 Claims, 3 Drawing Sheets

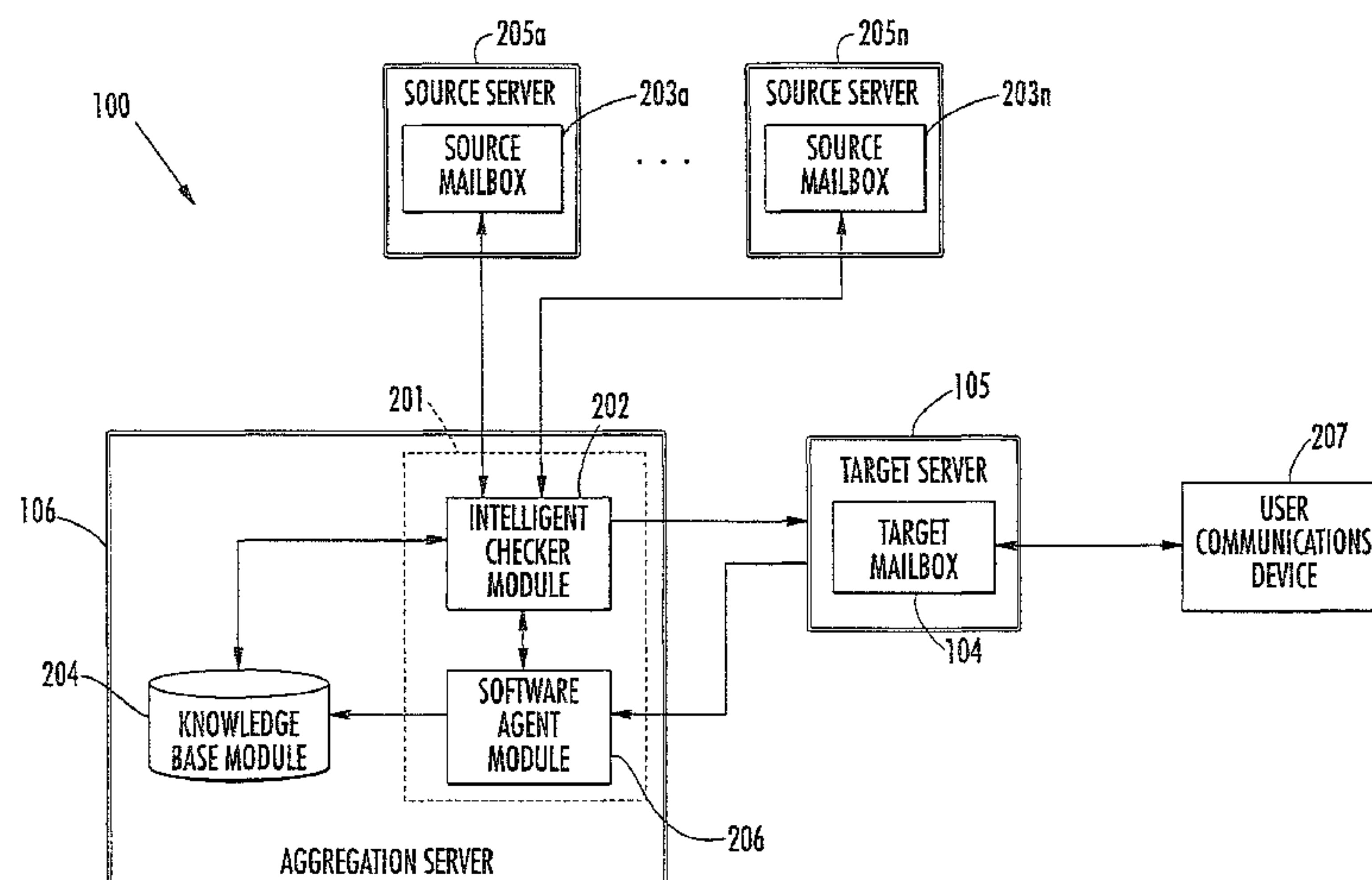

U.S. PATENT DOCUMENTS

6,070,191	A	5/2000	Narendran et al.	709/226
6,175,858	B1	1/2001	Bulfer et al.	709/206
6,182,139	B1 *	1/2001	Brendel	709/226
6,185,603	B1 *	2/2001	Henderson et al.	709/206
6,223,286	B1 *	4/2001	Hashimoto	713/178
6,389,455	B1	5/2002	Fuisz	709/206
6,421,732	B1	7/2002	Alkhafib et al.	709/245
6,438,583	B1	8/2002	McDowell	709/206
6,446,114	B1	9/2002	Bulfer et al.	709/206
6,549,937	B1	4/2003	Auerbach et al.	709/206
6,557,026	B1	4/2003	Stephens, Jr.	709/203
6,560,222	B1	5/2003	Pounds et al.	370/353
6,615,212	B1	9/2003	Dutta et al.	707/10
6,643,688	B1	11/2003	Fuisz	706/206
6,654,787	B1 *	11/2003	Aronson et al.	709/206
6,671,714	B1 *	12/2003	Weyer et al.	709/203
6,744,780	B1	6/2004	Gu et al.	370/450
6,842,773	B1	1/2005	Ralston et al.	709/206
6,854,007	B1	2/2005	Hammond	709/206
6,931,433	B1	8/2005	Ralston et al.	709/206
6,957,248	B2	10/2005	Quine et al.	709/206
6,959,324	B1	10/2005	Kubik et al.	709/206
7,010,572	B1	3/2006	Benjamin et al.	709/206
7,058,687	B2 *	6/2006	Kucherawy	709/206
7,200,636	B2 *	4/2007	Harding	709/206
7,395,314	B2 *	7/2008	Smith et al.	709/206
7,487,212	B2 *	2/2009	Taylor	709/206

2002/0026484	A1	2/2002	Smith	709/206
2002/0042815	A1 *	4/2002	Salzfass et al.	709/206
2002/0112007	A1	8/2002	Wood et al.	709/206
2002/0120690	A1	8/2002	Block	709/206
2002/0174194	A1	11/2002	Mooney et al.	709/219
2003/0028580	A1 *	2/2003	Kucherawy	709/101
2003/0134621	A1	7/2003	Yabe et al.	455/413
2003/0135573	A1 *	7/2003	Taylor	709/207
2004/0088357	A1 *	5/2004	Harding	709/206
2004/0221011	A1	11/2004	Smith et al.	709/206
2005/0010644	A1 *	1/2005	Brown et al.	709/206
2005/0020250	A1 *	1/2005	Chaddha et al.	455/414.1
2005/0039048	A1 *	2/2005	Tosey	713/201
2005/0055404	A1 *	3/2005	Kitchen, Jr.	709/206
2005/0278533	A1 *	12/2005	Mayer	713/170
2006/0075031	A1 *	4/2006	Wagner et al.	709/206
2006/0123085	A1 *	6/2006	Burns et al.	709/206
2006/0161626	A1 *	7/2006	Cardina et al.	709/206
2006/0179112	A1 *	8/2006	Weyer et al.	709/206
2007/0041327	A1 *	2/2007	Foster et al.	370/242
2008/0065730	A1 *	3/2008	Wilson	709/206

OTHER PUBLICATIONS

“eMail Bounce Handler”, <http://www.maxprog.com/EmailBounceHandler/html>, MAX Programming, LLC, 2001-2008, downloaded Jul. 16, 2009.

* cited by examiner

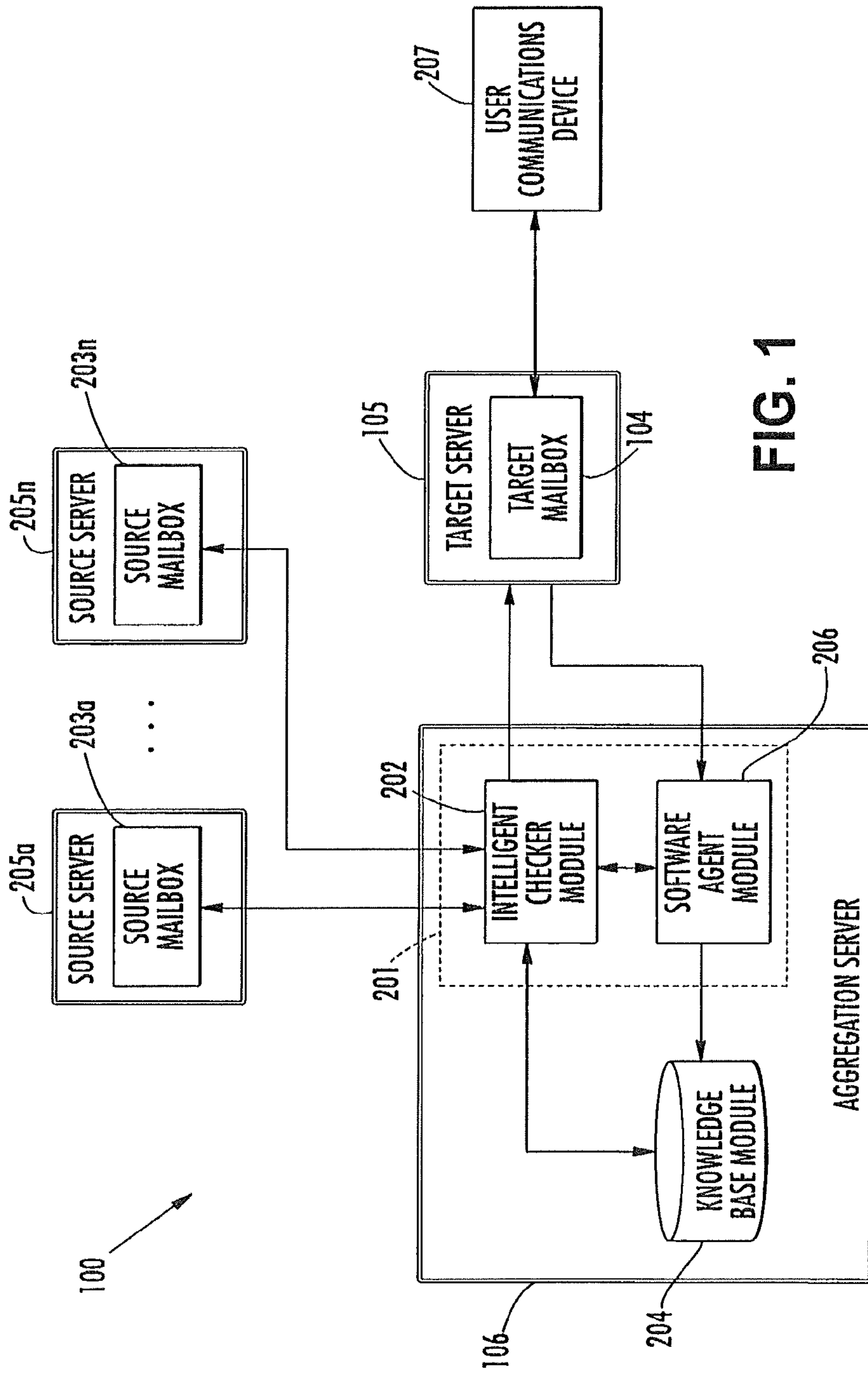

FIG. 1

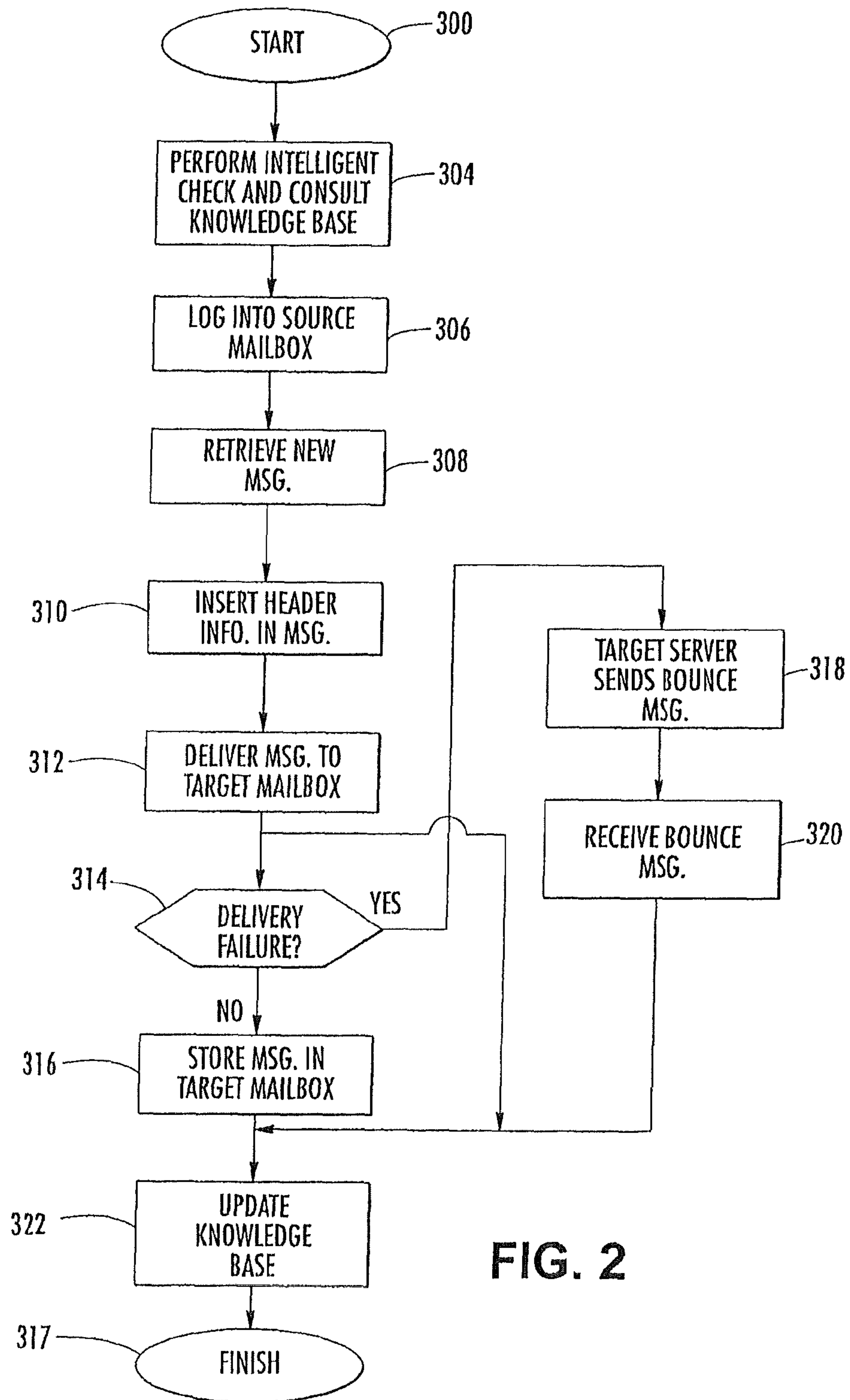

FIG. 2

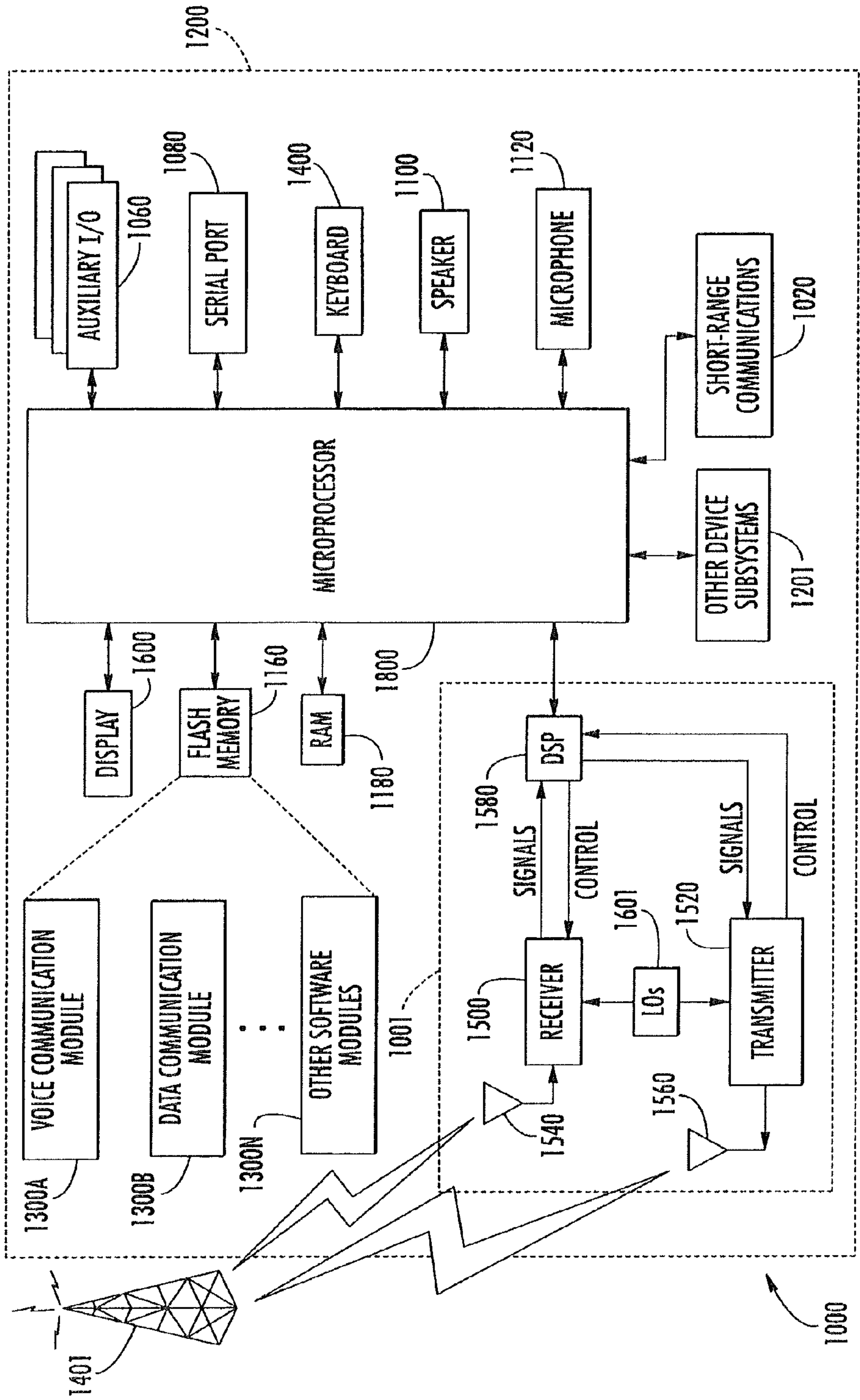

FIG. 3

COMMUNICATIONS SYSTEM PROVIDING MESSAGE AGGREGATION FEATURES AND RELATED METHODS

CROSS-REFERENCE TO RELATED APPLICATIONS

This application is a continuation of Ser. No. 11/459,227 filed Jul. 21, 2006 now U.S. Pat. No. 7,689,656, which, in turn, is a continuation of Ser. No. 10/779,350 filed Feb. 13, 2004 now U.S. Pat. No. 7,111,047 issued Sep. 19, 2006, which claims the benefit of U.S. Provisional Application No. 60/493,763, filed Aug. 8, 2003, all of which are hereby incorporated herein in their entireties by reference.

FIELD OF THE INVENTION

The present invention relates to the field of communications systems, and, more particularly, to electronic messaging systems and related methods.

BACKGROUND OF THE INVENTION

Electronic mailboxes are used to store electronic mail (e-mail) messages. Electronic mailboxes are connected to the Internet and use Internet protocols to send and receive incoming and outgoing e-mail messages. A user uses a mail program to compose and send messages. The sender's mail program communicates with the sender's mail server and delivers the message across the Internet to the recipient's mail server, where the message is deposited into the recipient's mailbox (or target mailbox) as a new incoming e-mail.

An e-mail system is an asynchronous send-and-forget messaging system. That is, e-mail is sent without any knowledge of whether it can successfully be delivered. If an e-mail message cannot be delivered, a new e-mail message, known as a delivery failure report or a bounce message, is generated by the target mail server and sent back to the originating mail server. The bounce message is deposited in the sender's mailbox, notifying the sender that delivery of the original message has failed.

The above single source and target e-mail server scenario works adequately if a user only has only one mailbox. However, most users today have more than one mailbox. A user might have one corporate e-mail account, one Internet service provider (ISP) e-mail account, and two or more free Web e-mail accounts (e.g., a Yahoo or Hotmail e-mail account). As a result, it may be difficult to keep up with and manage all of these different mailboxes.

One approach for providing better e-mail management with multiple mailboxes or accounts is to use an aggregated e-mail delivery system including an e-mail aggregation server. An e-mail aggregation server connects to multiple source mailboxes and consolidates the messages in one target mailbox. That is, these servers log on to existing mailboxes on behalf of the user, using credentials set up by the user, retrieve the messages from the mailboxes, and forward the messages to the target mailbox.

The target mailbox may be stored on the aggregation server, or it may be another e-mail account (i.e., the aggregation server acts as a e-mail forwarding agent). For example, for a user with ten e-mail accounts, it may be difficult for the user to check all these mailboxes regularly. Yet, an aggregation server may be used to pull down or aggregate messages from all ten accounts into one target mailbox.

Message delivery using aggregated e-mail servers simplifies the complexity of multiple mailbox management and

message delivery. However, there is one significant drawback. Aggregation servers typically do not address the problem of bounce messages. An e-mail delivery failure at a target mailbox generates a bounce message that results in three undesirable effects. First, the target server sending the bounce message attempts to address the original sender who sent the e-mail to the source mailbox. Since the aggregation server acts as an intermediary and forwards the message from the source mailbox to the target mailbox, the target server cannot know that the bounce message should not be sent to the original sender of the message from the source mailbox. The original sender is typically a third party with no interest in the aggregation, who is likely to be baffled by bounce messages originating from the target server; the original sender only knows about messages sent to the source mailbox server. Thus, bounce messages are not sent to the aggregation server (the intended destination of the bounce message), but instead to the original sender of the message.

Second, if a target mailbox is unable to accept delivery of new messages, there is no way to temporarily slow down or disable deliveries of messages until the target mailbox is once again able to accept mail. This means that bounce messages will continually be sent to the original sender of the message, potentially resulting in an endless message loop. Finally, the original message that triggered the bounce message is never delivered to the intended recipient.

One prior art approach for dealing with bounce messages has been implemented in a software program called eMail Bounce Handler from MaxProg. This program provides a bounce e-mail filtering and handling tool that recognizes bounce e-mails using a customizable set of rules and extracts the recipients addresses, allowing a user to use them again to try sending his mail or to take them off his list. eMail Bounce Handler connects to a post office protocol (POP) mailbox to retrieve bounces, and leaves any other messages untouched. Once the mailbox is processed and all bounces are removed, the program provides a list of "bad" e-mails addresses. The user may then export the list to clean his original address list, or to try to send the e-mail again.

Despite such e-mail bounce message handling approaches, further advancements in dealing with bounce e-mails may be desirable in certain applications.

SUMMARY OF THE INVENTION

In view of the foregoing background, it is therefore an object of the present invention to provide a communications system providing message aggregation and enhanced message delivery failure processing and related methods.

This and other objects, features, and advantages in accordance with the present invention are provided by a communications system which may include a plurality of source message servers for storing messages for delivery to a user, and a target message server having a target message box associated therewith. The system may also include an aggregation server for periodically aggregating the messages from the source message servers to the target message box for retrieval by the user. The target message server may provide a delivery failure message to the aggregation server based upon a failure to deliver a message to the target message box. As such, the aggregation server may increase a period of sending messages to the target message box based upon a delivery failure message therefrom, and thereafter decrease the period of sending messages to the target message box based upon a successful delivery of a message thereto.

More particularly, the aggregation server may selectively re-send messages for which delivery failure messages are

received. Additionally, the aggregation server may include an intelligent checker module for sending the messages to the target message server. Moreover, the aggregation server may further include a software agent module having a unique address associated therewith. The intelligent checker module may send the unique address with the messages to the target message server, and the target message box may send the delivery failure messages to the unique address. As such, the software agent module may associate the delivery failure messages with the respective target message box.

The aggregation server may further include a knowledge base module for cooperating with the software agent module for storing delivery failure information for the target message box. Further, the intelligent checker module may cooperate with the knowledge base module to increase or decrease the period of sending based thereon. Moreover, the knowledge base module may cooperate with the software agent module to store the delivery failure information for the target message box based upon a source message box identifier and a message identifier associated therewith.

The communications system may further include a communications device associated with the user for generating retrieving the messages from the target message box. By way of example, the messages may be electronic mail (e-mail) messages, and the communications device may be a mobile wireless communications device, for example.

A message aggregation method aspect of the invention may include periodically aggregating messages stored on a plurality of source message servers to a target message box for retrieval by a user. The method may further include generating delivery failure information based upon a failure to deliver a message to the target message box, and increasing a period of sending messages from the aggregation server to the target message box based upon the generation of delivery failure information therefor, and thereafter decreasing the period of sending messages to the target message box based upon a successful delivery of a message thereto.

An aggregation server in accordance with the present invention may include an aggregation module for aggregating messages stored on a plurality of source message servers to a target message box associated with a target server for retrieval by a user. The target message server may provide a delivery failure message to the aggregation module based upon a failure to deliver a message. Moreover, the aggregation server may further include a knowledge base module for cooperating with the aggregation module to store delivery failure information for the message box. The aggregation module may increase a period of sending messages to the target message box based upon a delivery failure message therefrom, and thereafter decrease the period of sending messages to the target message box based upon a successful delivery of a message thereto.

A computer-readable medium in accordance with the present invention may also include an aggregation module and a knowledge base module, such as those described briefly above.

BRIEF DESCRIPTION OF THE DRAWINGS

FIG. 1 is a schematic block diagram of a communications system in accordance with the present invention.

FIG. 2 is flow diagram illustrating a message aggregation method in accordance with the present invention.

FIG. 3 is a schematic block diagram of an exemplary mobile wireless communications device for use with the present invention.

DETAILED DESCRIPTION OF THE PREFERRED EMBODIMENTS

The present invention will now be described more fully hereinafter with reference to the accompanying drawings, in which preferred embodiments of the invention are shown. This invention may, however, be embodied in many different forms and should not be construed as limited to the embodiments set forth herein. Rather, these embodiments are provided so that this disclosure will be thorough and complete, and will fully convey the scope of the invention to those skilled in the art. Like numbers refer to like elements throughout.

Generally speaking, the present invention addresses the undesirable effects of bounce or delivery-failure messages by utilizing software modules, for example, to address the traditional shortcomings of aggregation servers. The bounce messages can be resolved by a message throttling mechanism performed by the aggregated server, which will be described further below.

An aggregated e-mail delivery system **100** in accordance with the invention is first described with reference to FIGS. 1 and 2. The components of the aggregated e-mail delivery system **100** illustratively include a respective source message box **203a-203n** residing on each of a plurality source servers **205a-205n**, a target message box **104** residing on a target server **105**, and an e-mail aggregation server **106**. The aggregation server **106** communicates bi-directionally with the other servers, as will be readily appreciated by those skilled in the art.

The source message boxes **203a-203n** (or sender's mailboxes) are "owned" by a particular user, and they hold messages for that user. The e-mail aggregation server **106** retrieves messages from each source message box **203a-203n**. The target message box **104** is where the e-mail aggregation server **106** forwards or aggregates the messages to. The target mail server **105** generates message delivery failure or bounce messages if it is unable to deliver a message to the target message box **104**, and the bounce message is sent to the e-mail aggregation server **106**. This may happen when the target message box **104** is full, for example, among other reasons, as will be appreciated by those skilled in the art.

Stated alternately, the e-mail aggregation server **106** is the bridging component that connects the source message boxes **205a-205n** with the target message box **104**. The e-mail aggregation server **106** aggregates messages from source message boxes **203a-203n** resident on the source servers **205a-205n** to the target message box **104**, and it includes various modules and agents to perform message throttling to resolve bounce messages, as will be described further below. The target message box **104** is accessed by a user's communications device **207**, which may be a personal computer (PC), personal digital assistant (PDA), etc., as will be appreciated by those of skill in the art. FIG. 3 is a schematic block diagram of an exemplary mobile wireless communications device for use with the present invention.

More particularly, the e-mail aggregation server **106** includes an aggregation module **201** including an intelligent checker module **202** and a software agent module **206**, and it also includes a knowledge base module **204**. The knowledge base module **204** is a centralized database used to store pertinent information regarding the source message boxes **203a-203n** and the target message box **104**. The software agent module **206** provides a response mechanism that is triggered once a bounce message is received from the target server **105** at the e-mail aggregation server **106**. Its task is to update the

target message box record at the knowledge base module **204** based upon the new delivery failure state of the target message box **104**.

The intelligent checker module **202** may conceptually be thought of as the “brain” of the e-mail aggregation server **106**. More particularly, the e-mail aggregation server **106** performs a number of functions. As noted above, it checks for new messages in the source message boxes **203a-203n** to send to the target message box **104**. It also queries and updates message box information at the knowledge base module **204**, throttles message delivery (as discussed further below), and cooperates with the software agent module **206** to process bounce messages from the target message box **104**.

As noted above, the e-mail aggregation server **106** is responsible for transferring e-mail from the source message boxes **203a-203n** to the target message box **104**. In the illustrated embodiment, the e-mail aggregation server **106** accomplishes this by retrieving messages from the source message boxes **203a-203n**, at which point certain transformations are made to the envelope and the headers thereof. However, the content or body of the e-mail messages is not modified. First, the envelope sender is changed to the unique e-mail address of the software agent module **206**. Any delivery failure or bounce messages will therefore be returned to the software agent module **206**. Second, additional information is added to each e-mail header section which uniquely identifies both the source message box **203** from which it came and the particular message stored therein that is being aggregated to the target message box **104**.

When a message cannot be delivered to the target message box **104**, a bounce message is generated and returned to the software agent module **206**. By inspecting the bounce message, the software agent module **206** is able to discover the identity of the target message box **104** and notify the knowledge base module **204** that the target message box is currently unable to receive e-mails. It should be noted that the aggregation server **106** will send messages to numerous target message boxes for numerous users, although only a single target message box **104** is shown in the exemplary embodiment for clarity of illustration.

The intelligent checker module **202** periodically checks the knowledge base module **204** for message box updates and uses this updated information to throttle message delivery. The intelligent checker module **202** may throttle (i.e., slow down, speed up or even completely stop) the period of sending further e-mails to the target message box **104** until a later time. Since the software agent module **206** is able to determine the unique identifier of the e-mail message, it is also able to re-attempt delivery of that message to the target message box **104** at a later time.

Turning now additionally to FIG. 2, an e-mail aggregation server message throttling decision path in accordance with the present invention is now described. Unless otherwise noted, the steps described below pertain to those performed by the e-mail aggregation server **106**. The process begins (Block **300**) with the intelligent checker module **202** consulting the knowledge base module **204** to get source message box information therefrom, at Block **304**. For example, the intelligent checker module **202** retrieves information such as the network addresses of the source message boxes **203a-203n**, credentials to access the source message boxes, and a list of messages at the source message boxes that have already been seen. It may also take into account if the target message box **104** is known to not be accepting delivery.

The intelligent checker module **202** then logs into the source message boxes **203a-203n**, at Block **306**, downloads new messages (Block **308**) therefrom, and temporarily stores

the new messages in a memory thereof (not shown). The intelligent checker module **202** then inserts new header information in each message, at Block **310**, and then delivers the message to the target message box **104**, at Block **312**.

If the delivery is a success (i.e., the message is successfully delivered to the target message box **104**), at Block **314**, the message is then stored in the target message box, at Block **316**, and the knowledge base **204** is updated to include the unique mail identifiers, at Block **322**, thus concluding the illustrated method (Block **317**). However, if the delivery is a failure (i.e., the message cannot be delivered to the target message box **104**), the target mail server **105** sends a delivery failure notification message or bounce message back to the aggregation e-mail server **106**, at Block **318**.

The software agent module **206** receives the bounce message (because of the unique identifier of the software agent module inserted in the message header), at Block **320**, and it updates the knowledge base module **204** with the delivery failure information, at Block **322**. More particularly, the software agent module **206** inspects the bounce message, determines which source message box **203**, target message box **104**, and specific e-mail message are involved in the delivery failure. This information is then saved in the knowledge base module **204** for future reference, thus concluding the illustrated method.

After the failure information is saved, the intelligent checker module **206** loops back to perform an intelligent check, and the system repeats itself. The intelligent checker module **206** may then use the intelligent check step (Block **302**) to throttle message flow. That is, the intelligent checker module **206** may slow down (i.e., increase the period of sending), speed up (i.e., decrease the period of sending) or stop future attempts to send e-mail to the target message box **104**, and can also support failed e-mail retries, as noted above.

It should be noted that in some embodiments the target message box **104** may reside on the aggregation server **106**, such as if the target message box was hosted by an Internet service provider (ISP) that also provided the above-described aggregation features. Also, the various modules shown as residing on the aggregation server **106** may be implemented as software modules, and they could be spread across different servers or machines, as will be appreciated by those skilled in the art.

As also noted above, various prior art e-mail aggregation products are available. Two examples include Fetchmail and the eMail Bounce Handler program noted above. While Fetchmail does perform e-mail aggregation, it does not have a software agent or shared knowledge base, and it cannot implement throttling or a message retry/re-send when a target message box **104** is unavailable. As briefly noted above, eMail Bounce Handler is consumer-grade solution focused on removing malicious e-mail addresses from mailing lists. Yet, this product is not particularly well-suited for use in a high-scalability, multi-user server environment, nor does it provide throttling capabilities.

EXAMPLE

An exemplary hand-held mobile wireless communications device **1000** that can be used in the present invention is further described in the example below with reference to FIG. 3. The device **1000** includes a housing **1200**, a keyboard **1400** and an output device **1600**. The output device shown is a display **1600**, which is preferably a full graphic LCD. Other types of output devices may alternatively be utilized. A processing device **1800** is contained within the housing **1200** and is coupled between the keyboard **1400** and the display **1600**.

The processing device **1800** controls the operation of the display **1600**, as well as the overall operation of the mobile device **1000**, in response to actuation of keys on the keyboard **1400** by the user.

The housing **1200** may be elongated vertically, or may take on other sizes and shapes (including clamshell housing structures). The keyboard may include a mode selection key, or other hardware or software for switching between text entry and telephony entry.

In addition to the processing device **1800**, other parts of the mobile device **1000** are shown schematically in FIG. 3. These include a communications subsystem **1001**; a short-range communications subsystem **1020**; the keyboard **1400** and the display **1600**, along with other input/output devices **1060**, **1080**, **1100** and **1120**; as well as memory devices **1160**, **1180** and various other device subsystems **1201**. The mobile device **1000** is preferably a two-way RF communications device having voice and data communications capabilities. In addition, the mobile device **1000** preferably has the capability to communicate with other computer systems via the Internet.

Operating system software executed by the processing device **1800** is preferably stored in a persistent store, such as the flash memory **1160**, but may be stored in other types of memory devices, such as a read only memory (ROM) or similar storage element. In addition, system software, specific device applications, or parts thereof, may be temporarily loaded into a volatile store, such as the random access memory (RAM) **1180**. Communications signals received by the mobile device may also be stored in the RAM **1180**.

The processing device **1800**, in addition to its operating system functions, enables execution of software applications **1300A-1300N** on the device **1000**. A predetermined set of applications that control basic device operations, such as data and voice communications **1300A** and **1300B**, may be installed on the device **1000** during manufacture. In addition, a personal information manager (PIM) application may be installed during manufacture. The PIM is preferably capable of organizing and managing data items, such as e-mail, calendar events, voice mails, appointments, and task items. The PIM application is also preferably capable of sending and receiving data items via a wireless network **1401**. Preferably, the PIM data items are seamlessly integrated, synchronized and updated via the wireless network **1401** with the device user's corresponding data items stored or associated with a host computer system.

Communication functions, including data and voice communications, are performed through the communications subsystem **1001**, and possibly through the short-range communications subsystem. The communications subsystem **1001** includes a receiver **1500**, a transmitter **1520**, and one or more antennas **1540** and **1560**. In addition, the communications subsystem **1001** also includes a processing module, such as a digital signal processor (DSP) **1580**, and local oscillators (LOs) **1601**. The specific design and implementation of the communications subsystem **1001** is dependent upon the communications network in which the mobile device **1000** is intended to operate. For example, a mobile device **1000** may include a communications subsystem **1001** designed to operate with the Mobitex™, Data TAC™ or General Packet Radio Service (GPRS) mobile data communications networks, and also designed to operate with any of a variety of voice communications networks, such as AMPS, TDMA, CDMA, PCS, GSM, etc. Other types of data and voice networks, both separate and integrated, may also be utilized with the mobile device **1000**.

Network access requirements vary depending upon the type of communication system. For example, in the Mobitex

and DataTAC networks, mobile devices are registered on the network using a unique personal identification number or PIN associated with each device. In GPRS networks, however, network access is associated with a subscriber or user of a device. A GPRS device therefore requires a subscriber identity module, commonly referred to as a SIM card, in order to operate on a GPRS network.

When required network registration or activation procedures have been completed, the mobile device **1000** may send and receive communications signals over the communication network **1401**. Signals received from the communications network **1401** by the antenna **1540** are routed to the receiver **1500**, which provides for signal amplification, frequency down conversion, filtering, channel selection, etc., and may also provide analog to digital conversion. Analog-to-digital conversion of the received signal allows the DSP **1580** to perform more complex communications functions, such as demodulation and decoding. In a similar manner, signals to be transmitted to the network **1401** are processed (e.g. modulated and encoded) by the DSP **1580** and are then provided to the transmitter **1520** for digital to analog conversion, frequency up conversion, filtering, amplification and transmission to the communication network **1401** (or networks) via the antenna **1560**.

In addition to processing communications signals, the DSP **1580** provides for control of the receiver **1500** and the transmitter **1520**. For example, gains applied to communications signals in the receiver **1500** and transmitter **1520** may be adaptively controlled through automatic gain control algorithms implemented in the DSP **1580**.

In a data communications mode, a received signal, such as a text message or web page download, is processed by the communications subsystem **1001** and is input to the processing device **1800**. The received signal is then further processed by the processing device **1800** for an output to the display **1600**, or alternatively to some other auxiliary I/O device **1060**. A device user may also compose data items, such as e-mail messages, using the keyboard **1400** and/or some other auxiliary I/O device **1060**, such as a touchpad, a rocker switch, a thumb-wheel, or some other type of input device. The composed data items may then be transmitted over the communications network **1401** via the communications subsystem **1001**.

In a voice communications mode, overall operation of the device is substantially similar to the data communications mode, except that received signals are output to a speaker **1100**, and signals for transmission are generated by a microphone **1120**. Alternative voice or audio I/O subsystems, such as a voice message recording subsystem, may also be implemented on the device **1000**. In addition, the display **1600** may also be utilized in voice communications mode, for example to display the identity of a calling party, the duration of a voice call, or other voice call related information.

The short-range communications subsystem enables communication between the mobile device **1000** and other proximate systems or devices, which need not necessarily be similar devices. For example, the short-range communications subsystem may include an infrared device and associated circuits and components, or a Bluetooth™ communications module to provide for communication with similarly-enabled systems and devices.

Many modifications and other embodiments of the invention will come to the mind of one skilled in the art having the benefit of the teachings presented in the foregoing descriptions and the associated drawings. Therefore, it is understood that the invention is not to be limited to the specific embodi-

ments disclosed, and that modifications and embodiments are intended to be included within the scope of the appended claims.

That which is claimed is:

1. A communications system comprising:

a plurality of source message servers, each comprising a processor, and configured to store electronic mail (e-mail) messages in source message boxes;

a target message server, comprising a processor, and having a target message box associated therewith; and

an aggregation server, comprising a processor, and configured to

store information regarding the source message boxes and the target message box,

aggregate the e-mail messages from the source message servers to the target message server,

change an envelope sender of the e-mail messages to a unique e-mail address of the aggregation server that is different from an address associated with the target message box and the envelope sender,

increase a period of sending e-mail messages to the target message box and update the stored information based upon receipt of an e-mail delivery failure message at the unique e-mail address from the target message box,

decrease the period of sending e-mail messages to the target message box and update the stored information based upon at least one successful e-mail delivery, and

selectively re-send e-mail messages at a period based upon the stored information.

2. The communications system of claim **1** wherein said aggregation server is also configured to execute an intelligent checker module for aggregating the e-mail messages from said source servers to said target message box.

3. The communications system of claim **2** wherein said aggregation server is also configured to execute a software agent module having the unique address associated therewith; wherein said intelligent checker module is also configured to send the unique address with the e-mail messages to the target message box; wherein said target message server is configured to send delivery failure messages to the unique address; and wherein said software agent module is configured to associate the delivery failure messages with the target message box.

4. The communications system of claim **3** wherein said aggregation server is also configured to execute a knowledge base module for cooperating with said software agent module for storing delivery failure information for the target message box; and wherein said intelligent checker module is also configured to cooperate with said knowledge base module to increase or decrease the period of sending based upon the stored delivery failure information.

5. The communications system of claim **4** wherein said knowledge base module is also configured to cooperate with said software agent module to store the delivery failure information for the target message box based upon a source message box identifier and a message identifier associated therewith.

6. The communications system of claim **1** further comprising a user-associated communications device configured to access the messages from the target message box.

7. The communications system of claim **6** wherein said user-associated communications device comprises a mobile wireless communications device.

8. An electronic mail (e-mail) message aggregation server comprising:

a processor configured to execute an aggregation module for

storing information regarding source message boxes and a target message box,

aggregating e-mail messages stored in the source message boxes on a plurality of source message servers to the target message box

changing an envelope sender of the messages to a unique e-mail address of the e-mail message aggregation server that is different from an address associated with the target message box and the envelope sender,

increase a period of sending e-mail messages to the target message box and update the stored information based upon receipt of at least one e-mail delivery failure message at the unique e-mail address from the target message box,

decrease the period of sending e-mail messages to the target message box and update the stored information based upon at least one successful e-mail delivery, and

selectively re-send e-mail messages at a period based upon the stored information.

9. The e-mail aggregation server of claim **8** wherein said aggregation module comprises:

an intelligent checker module configured to periodically aggregate e-mail messages stored on the plurality of source message servers to the target message box; and

a software agent module having the unique address associated therewith and configured to associate delivery failure messages with the target message box;

said intelligent checker module configured to send the unique address with the e-mail messages to the target message box.

10. The e-mail aggregation server of claim **9** wherein said intelligent checker module is also configured to cooperate with said software agent module to store the delivery failure information for the target message box based upon a source message box identifier and a message identifier associated therewith.

11. An electronic mail (e-mail) message aggregation method comprising:

operating an aggregation server, comprising a processor, to store information regarding source message boxes and a target message box,

periodically aggregate e-mail messages stored on a plurality of source message servers to a target message box,

change an envelope sender of the messages to a unique e-mail address of the aggregation server that is different from an address associated with the target message box and the envelope sender,

increase a period of sending messages to the target message box and update the stored information based upon receipt of at least one e-mail delivery failure message at the unique e-mail address from the target message box,

decrease the period of sending messages to the target message box and update the stored information based upon at least one successful e-mail delivery, and

selectively re-send e-mail messages at a period based upon the stored information.

12. The method of claim **11** wherein operating the aggregation server further comprises operating the aggregation server to execute an

11

intelligent checker module for aggregating the e-mail messages from the source servers to the target message box.

13. The method of claim **12** wherein operating the aggregation server further comprises operating the aggregation server to execute a software agent module having the unique address associated therewith; wherein executing the intelligent checker module is also for sending the unique address with the e-mail messages to the target message box; and wherein executing the software agent module is also for associating the delivery failure messages with the target message box.

14. The method of claim **13** wherein operating the aggregation server further comprises operating the aggregation

12

server to execute a knowledge base module for cooperating with the software agent module for storing delivery failure information for the target message box; and wherein executing the intelligent checker module is for cooperating with the knowledge base module to increase or decrease the period of sending based upon the stored delivery failure information.

15. The method of claim **14** wherein executing the knowledge base module is for cooperating with the software agent module to store the delivery failure information for the target message box based upon a source message box identifier and a message identifier associated therewith.

* * * * *