

US008362957B2

(12) **United States Patent**
Lehtola et al.

(10) **Patent No.:** **US 8,362,957 B2**
(45) **Date of Patent:** **Jan. 29, 2013**

(54) **RADIATION PATTERN CONTROL**

(75) Inventors: **Antero Lehtola**, Turku (FI); **Aimo Arkko**, Ruutana (FI)

(73) Assignee: **Nokia Corporation**, Espoo (FI)

(*) Notice: Subject to any disclaimer, the term of this patent is extended or adjusted under 35 U.S.C. 154(b) by 519 days.

(21) Appl. No.: **12/449,631**

(22) PCT Filed: **Feb. 28, 2007**

(86) PCT No.: **PCT/IB2007/001678**

§ 371 (c)(1),
(2), (4) Date: **Aug. 18, 2009**

(87) PCT Pub. No.: **WO2008/104826**

PCT Pub. Date: **Sep. 4, 2008**

(65) **Prior Publication Data**

US 2010/0315293 A1 Dec. 16, 2010

(51) **Int. Cl.**
H01Q 1/38 (2006.01)

(52) **U.S. Cl.** **343/700 MS**; 343/702

(58) **Field of Classification Search** 343/700 MS,
343/829, 846, 847, 702

See application file for complete search history.

(56) **References Cited**

U.S. PATENT DOCUMENTS

5,631,659	A *	5/1997	Evans et al.	343/700 MS
7,983,721	B2 *	7/2011	Ying et al.	455/575.1
2004/0037052	A1	2/2004	Wu et al.	361/752
2004/0046701	A1	3/2004	Huber et al.	343/702
2005/0285798	A1	12/2005	van Wouterghem et al. .	343/702
2006/0082514	A1	4/2006	Chiang et al.	343/794
2006/0181468	A1	8/2006	Iguchi et al.	343/702
2009/0213026	A1 *	8/2009	Lindberg et al.	343/848

FOREIGN PATENT DOCUMENTS

EP	1583172	A2	10/2005
EP	1626457	A1	2/2006
EP	1638165	A1	3/2006
EP	1755190	A1	2/2007
SE	528327	C2	10/2006
WO	WO 2004/084344	A1	9/2004
WO	WO-2007004499	A1	1/2007
WO	WO-2007043941	A1	4/2007

* cited by examiner

Primary Examiner — Dieu H Duong

(74) *Attorney, Agent, or Firm* — Harrington & Smith

(57) **ABSTRACT**

An apparatus including: a first antenna element; a second antenna element; a ground plane element for at least one of the first and second antenna elements; a first choke arranged to affect a first maximum of current density produced in the ground plane element by the first antenna element; and a second choke arranged to affect a second maximum of current density produced in the ground plane element by the second antenna element.

30 Claims, 1 Drawing Sheet

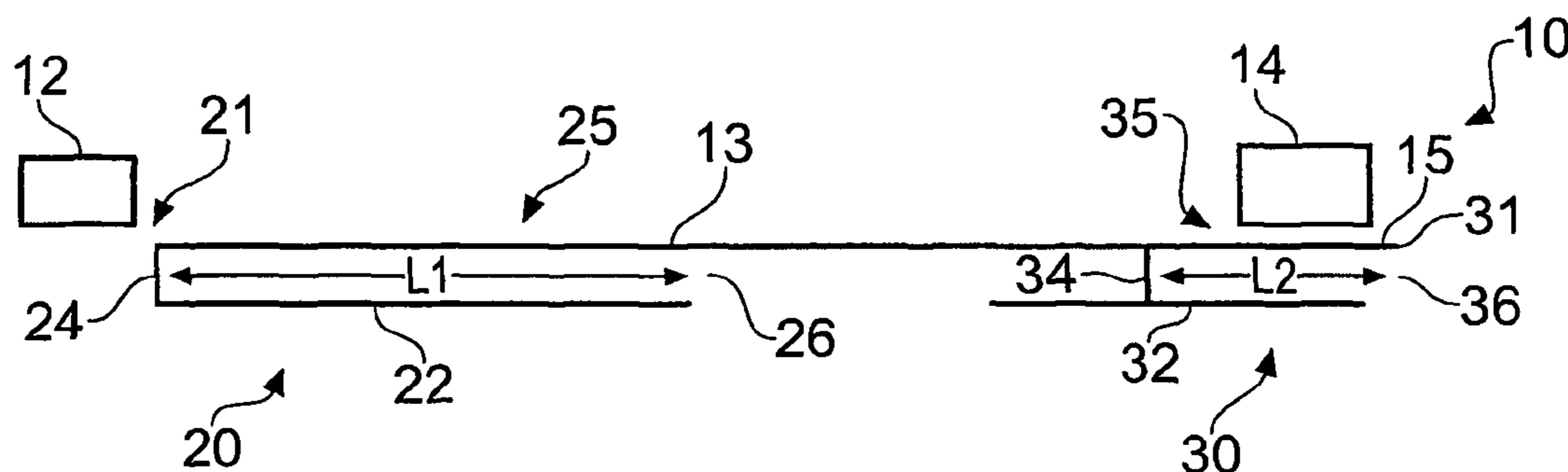

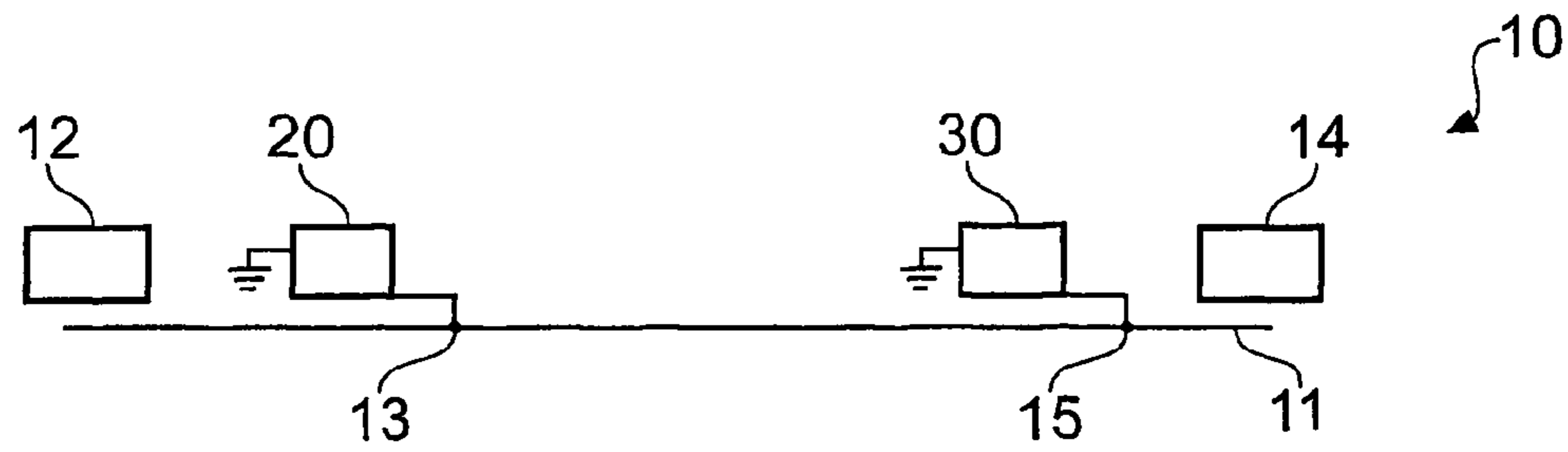

Fig. 1

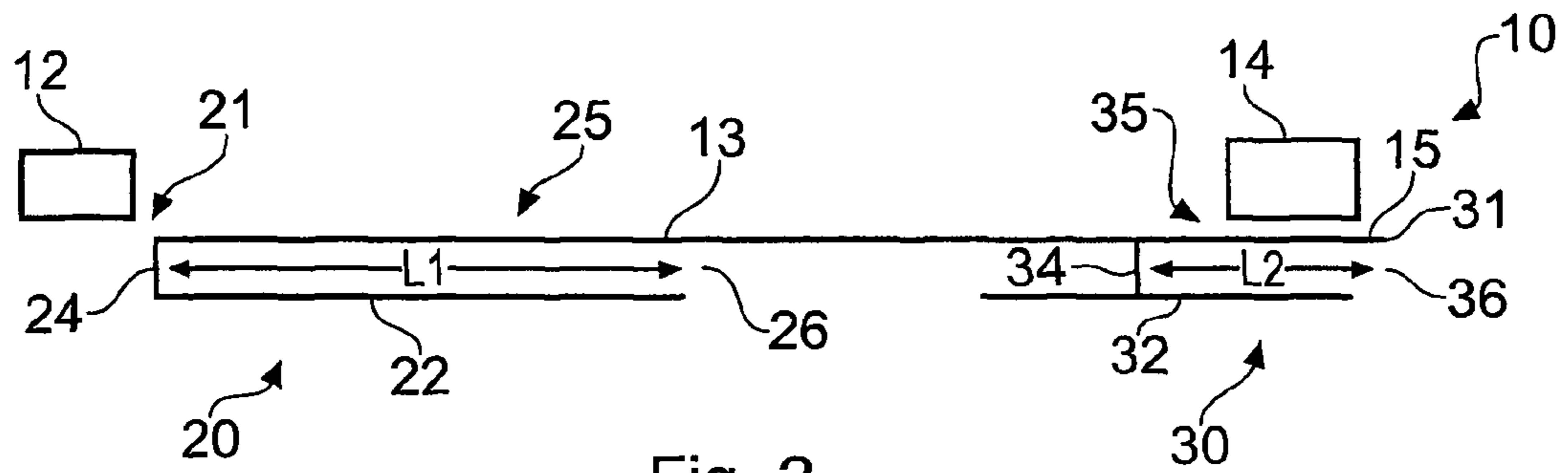

Fig. 2

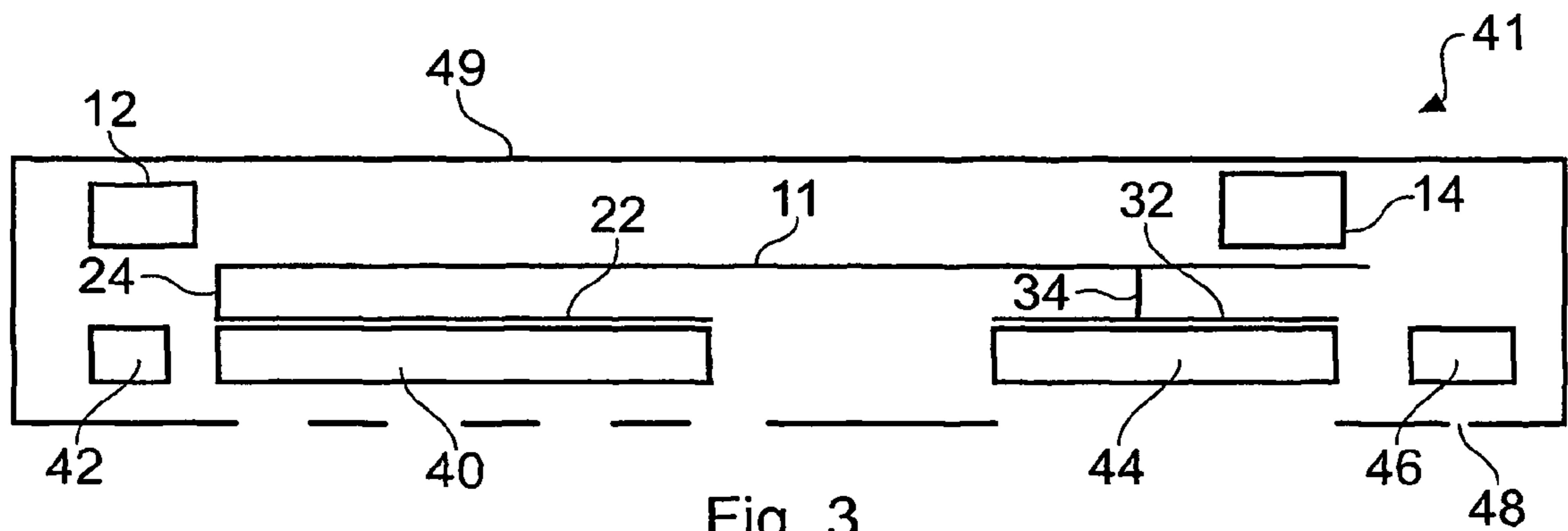

Fig. 3

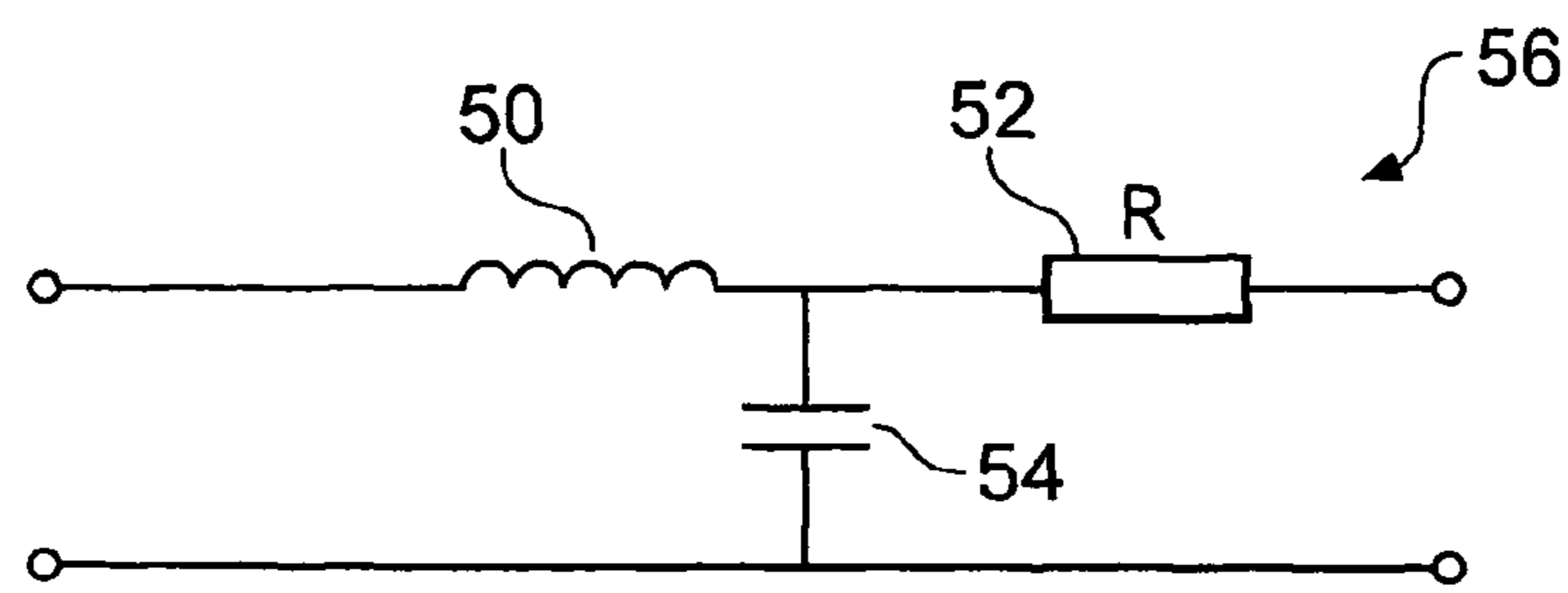

Fig. 4

1

RADIATION PATTERN CONTROL

FIELD OF THE INVENTION

Embodiments of the present invention relate to radiation pattern control.

BACKGROUND TO THE INVENTION

A radio transmission apparatus radiates radio frequency (RF) electromagnetic energy in a radiation pattern. The radio transmission apparatus typically has at least one antenna element that is used to control the characteristics of the radiation pattern such as its shape at one or more particular RF frequencies.

The radiation pattern is dependent upon the RF electric currents in the radio transmission apparatus. RF electric currents are driven in the antenna element and may also exist in other conductive elements within the radio transmission apparatus such as a ground plane.

It is often desirable to control the shape of a radiation pattern so that the radio transmission apparatus radiates more strongly in a first direction than a second direction. This control improves the efficiency of the radio transmission apparatus in the first direction at the expense of efficiency in the second direction.

It would be desirable to control electric currents that exist within a conductive element, particularly a ground plane, and thereby control the radiation pattern of the radio transmission apparatus.

BRIEF DESCRIPTION OF THE INVENTION

According to some embodiments of the invention there is provided an apparatus comprising: a first antenna element; a second antenna element; a ground plane element coupled to at least one of the first and second antenna elements; a first choke arranged to affect a first maximum of current density produced in the ground plane element by the first antenna element; and a second choke arranged to affect a second maximum of current density produced in the ground plane element by the second antenna element.

The first choke affects the first maximum of current density by suppressing the intensity of the first maximum of the current density. The second choke affects the second maximum of current density by suppressing the intensity of the second maximum of the current density. Suppression of a maximum in current density may result in changing the location of a maximum of the current density.

According to some embodiments of the invention there is provided an apparatus comprising: a first antenna element; a second antenna element; a conductive element having a first region and a second region; a first transmission line comprising a first end having a low impedance load and a second end positioned adjacent the first region; and a second transmission line comprising a first end having a low impedance load and a second end positioned adjacent the second region.

According to some embodiments of the invention there is provided a method comprising: suppressing electric current, at a resonant frequency of a first antenna element, at a first region of an apparatus, wherein the apparatus comprises the first antenna element and a second antenna element; and suppressing electric current, at a resonant frequency of the second antenna element, at a second, different, region of the apparatus.

2

BRIEF DESCRIPTION OF THE DRAWINGS

For a better understanding of the present invention reference will now be made by way of example only to the accompanying drawings in which:

FIG. 1 schematically illustrates one embodiment of a radio transmission apparatus;

FIG. 2 schematically illustrates another embodiment of a radio transmission apparatus;

FIG. 3 schematically illustrates a mobile cellular telephone; and

FIG. 4 schematically illustrates an equivalent circuit for a transmission line.

DETAILED DESCRIPTION OF EMBODIMENTS OF THE INVENTION

FIG. 1 schematically illustrates an apparatus 10 comprising a first antenna element 12, a second antenna element 14, a ground plane element 11, a first choke 20 and a second choke 30. The apparatus 10 is capable of transmitting RF radio waves. It may also be capable of receiving RF radio waves.

One or both of the first antenna element 12 and the second antenna element 14 use the conductor 11 as a ground plane.

The first antenna element 12 has a resonant frequency f_1 that has a corresponding resonant wavelength λ_1 . In use the first antenna element 12 creates a high electric current density at a first region 13 of the ground plane 11.

The first choke 20 suppresses large electric current densities at the first region 13. This reduces the electric current density at the first region 13. The first choke 20 is a frequency-dependent impedance that has a low input impedance at the resonant frequency f_1 .

The second antenna element 14 has a resonant frequency f_2 that has a corresponding resonant wavelength λ_2 . In use the second antenna element 14 creates a high electric current density at a second region 15 of the ground plane 11.

The second choke 30 suppresses large electric current densities at the second region 15. This reduces the electric current density at the second region 15. The second choke 30 is a frequency dependent impedance that has a low input impedance at the resonant frequency f_2 .

The presence and positioning of the first and second chokes modifies the distribution of electric currents in the ground plane 11 and reduces the maximum current densities at the regions 13 and 15.

FIG. 2 schematically illustrates an embodiment of the apparatus 10 and like reference numerals refer to like elements. The apparatus may be, for example, a radio communication device or a module for a radio communication device.

The first choke 20 comprises a quarter wavelength transmission line 25 formed by the combination of the ground plane 11 and a first conductor 22. The first conductor 22 runs parallel to the ground plane 11. The parallel combination of the first conductor 22 and the ground plane 11 forms a transmission line 25 that has a first end 24 and a second end 26. The second end 26 is positioned adjacent the first region 13 of the ground plane 11 and the first end 24 is positioned a distance L_1 away where $L_1 = \lambda_1/4$. In this example, the first end is positioned at an extremity 21 of the ground plane 11 adjacent the first antenna element 12 and the second end 26 is positioned towards the center of the ground plane 11.

The first end 24 of the transmission line 25 has a low impedance load formed by the galvanic connection of the first conductor 22 to the ground plane 11. This low impedance

load forces the ground plane currents to have current maximum at this connection point. The (electrical) length L_1 of the transmission line i.e. the distance between the first end **24** and the second end **26** corresponds to $\lambda/4$,

The input impedance to the transmission line **25** at the second end **26** is selectively high at the resonant frequency f_1 of the first antenna element **12** and the input impedance to the transmission line **25** at the first end **24** is low. The transmission line **25** relocates the maximum in the current density from the first region **13** of the ground plane **11**. The current density at the first region **13** is therefore reduced.

The second choke **30** comprises a quarter wavelength transmission line **35** formed by the combination of the ground plane **11** and a second conductor **32**. The second conductor **32** runs parallel to the ground plane **11**. The parallel combination of the second conductor-**32** and the ground plane **11** forms a transmission line that has a first end **34** and a second end **36**. The second end **36** is positioned adjacent the second region **15** of the ground plane **11** and the first end **34** is positioned a distance L_2 away where $L_2 = \lambda/4$. In this example, the second end **36** is positioned at an extremity **31** of the ground plane **11** adjacent the second antenna element **14** and the first end **34** is positioned towards the center of the ground plane **11**.

The first end **34** of the transmission line **30** has a low impedance load formed by the galvanic connection of the second conductor **32** to the ground plane **11**. This low impedance load forces the ground plane currents to have current maximum at this connection point.

The input impedance to the transmission line **35** at the second end **36** is selectively high at the resonant frequency f_2 of the second antenna element **14** and the input impedance to the transmission line **35** at the first end **34** is low. The transmission line **35** relocates the maximum in the current density from the second region **15** of the ground plane **11**. The current density at the second region **15** is therefore reduced.

It will be appreciated that for a particular transmission line, the open or floating second end **36** should be positioned adjacent to a region of maximum current density created by an antenna element and the electrical length of the transmission line should be a quarter wavelength (at the resonant frequency of the antenna element). The position of the closed first end may be positioned to accommodate these constraints.

In the illustrated embodiment, the first antenna element **12** is an off ground antenna element. That is, it is positioned so that it does not overlie the ground plane **11**. The first antenna element **12** may be for example, an internal monopole. The second antenna element **14** is an on ground antenna element. That is, it is positioned so that it overlies the ground plane **11**. The second antenna element **14** may be, for example, a planar inverted antenna such as a planar inverted F antenna (PIFA) or a planar inverted L antenna (PILA). It should, however, be appreciated that different positioning and types of antenna elements may be used.

In this implementation, the first antenna element **12** is a low band antenna element and the second antenna element **14** is a high band antenna element. However, in other implementations the second antenna element **14** could be a low band antenna element and the first antenna element **12** could be a high band antenna element.

The low and high bands may be any transmitting bands of the following bands so long as the high band is at a higher frequency than the lower band: AM radio (0.535-1.705 MHz); FM radio (76-108 MHz); Bluetooth (2400-2483.5 MHz); WLAN (2400-2483.5 MHz); HLAN (5150-5850 MHz); GPS (1570.42-1580.42 MHz); US-GSM 850 (824-894 MHz); EGSM 900 (880-960 MHz); EU-WCDMA 900 (880-960 MHz); PCN/DCS 1800 (1710-1880 MHz); US-WCDMA

1900 (1850-1990 MHz); WCDMA 2100 (Tx: 1920-1980 MHz Rx: 2110-2180 MHz); PCS1900 (1850-1990 MHz); UWB Lower (3100-4900 MHz); UWB Upper (6000-10600 MHz); DVB-H (470-702 MHz); DVB-H US (1670-1675 MHz); DRM (0.15-30 MHz); Wi Max (2300-2400 MHz, 2305-2360 MHz, 2496-2690 MHz, 3300-3400 MHz, 3400-3800 MHz, 5250-5875 MHz); DAB (174.928-239.2 MHz, 1452.96-1490.62 MHz); RFID LF (0.125-0.134 MHz); RFID HF (13.56-13.56 MHz); RFID UHF (433 MHz, 865-956 MHz, 2450 MHz).

FIG. 3 schematically illustrates a radio communication device mobile cellular telephone **41** that comprises the apparatus **10** illustrated in FIG. 2. In addition, the mobile telephone **41** comprises a housing **49**, a keypad **40**, a microphone **42**, a display **44** and a loudspeaker **46**. There is also a loudspeaker port **48** in the housing **49** adjacent the loudspeaker **46**.

Although in the Figure, the loudspeaker **48** and the second antenna element **14** are illustrated as separate components, this is only for clarity of illustration. The loudspeaker **48** may be an integral part of the second antenna element **14**.

The display **44**, in this example, has a metal shield that provides the second conductor **32**.

The keypad **40** has, in this example, a printed wiring board (PWB) that provides the first conductor **22**.

In this implementation, the first antenna element **12** is a low band antenna element and the second antenna element **14** is a high band antenna element. However, in other implementations the second antenna element **14** could be a low band antenna element and the first antenna element **12** could be a high band antenna element.

As an example, the low band may correspond to EGSM and/or US-GSM and the high band may correspond to PCN/DCS and/or PCS1900 or US-WCDMA and/or WCDMA2100 and/or WLAN or Bluetooth.

The first antenna element **12** on the second antenna element **14** may be separated by almost the full length of the mobile telephone **41**. In this example the PWB of the mobile telephone **41** is used as the ground plane **11**. The antenna element at the top of the phone, adjacent the loudspeaker port **48**, is typically an on ground antenna element i.e. it overlies the ground plane **11**.

In other implementations the first antenna element **12** could also be on the same end of the ground plane as the second antenna element **14**. In this position the first antenna element **12** would similarly create a high electric current density at a first region **13** of the ground plane **11** if current densities at a first region **13** are due to the ground plane resonance currents and then the position of this high current density region **13** does not depend on where the first antenna element **12** is positioned on the ground plane **11**. Thus in this case the first choke **20** would similarly suppress the large electric current densities at the first region **13** of the ground plane **11**.

FIG. 4 schematically illustrates an equivalent circuit **56** for a transmission line. The equivalent circuit **56** comprises an inductance **50**, a resistance **52** and a capacitance **54**. Additionally, a shunt resistor (not illustrated) may complete the equivalent circuit of a transmission line, which represents conductance. Although these impedances are illustrated as lumped components, in a transmission line they are typically wholly or partially distributed.

In the above described embodiment of FIG. 2, it has been described that the length L_1 is dependent upon the resonant frequency of the first antenna element and that the length L_2 is dependent upon the resonant frequency of the second antenna element **14**. However, the physical length of the

5

transmission lines may be reduced by using dielectric material in the gap between the conductive element and the ground plane.

In some embodiments the transmission lines may be augmented with lumped impedances. Such lumped components could be used to reduce the physical length of a transmission line while maintaining its effective electrical length.

In some embodiments the transmission lines may be replaced with lumped impedances.

Although embodiments of the present invention have been described in the preceding paragraphs with reference to various examples, it should be appreciated that modifications to the examples given can be made without departing from the scope of the invention as claimed.

Whilst endeavoring in the foregoing specification to draw attention to those features of the invention believed to be of particular importance it should be understood that the Applicant claims protection in respect of any patentable feature or combination of features hereinbefore referred to and/or shown in the drawings whether or not particular emphasis has been placed thereon.

We claim:

1. An apparatus comprising:

a first antenna element;

a second antenna element;

a ground plane element coupled to at least one of the first and second antenna elements;

a first transmission line, formed by a first conductor and the ground plane element, arranged to affect a first maximum of current density produced in the ground plane element by the first antenna element;

wherein the first transmission line is terminated at a first end by a low impedance load and is terminated by a high impedance load at a second end; and

a second transmission line arranged to affect a second maximum of current density produced in the ground plane element by the second antenna element;

wherein the first end of the first transmission line is closer to the first antenna element than the second end of the first transmission line, and wherein the second end of the first transmission line is positioned adjacent the region of maximum current density produced in the ground plane element by the first antenna element.

2. The apparatus as claimed in claim 1, wherein the low impedance load is a galvanic short-circuit connection between the first conductor and the ground plane.

3. The apparatus as claimed in claim 2, wherein the high impedance load is an open circuit gap between the first conductor and the ground plane.

4. The apparatus as claimed in claim 1, wherein the first end of the first transmission line is positioned to achieve a desired position for the second end of the first transmission line and a desired length for the first transmission line.

5. The apparatus as claimed in claim 1, wherein the first antenna element has a first resonant frequency that has a corresponding first resonant wavelength and the first transmission line has a length equivalent to one quarter of the first resonant wavelength.

6. The apparatus as claimed in claim 1, wherein the second transmission line is formed by a second conductor and the ground plane.

7. The apparatus as claimed in claim 6, wherein the second transmission line is terminated at a first end by a second low impedance load and a second high impedance load at a second end.

6

8. The apparatus as claimed in claim 7, wherein the second low impedance load is a short-circuit connection between the second conductor and the ground plane.

9. The apparatus as claimed in claim 7, wherein the second end of the second transmission line is positioned adjacent a region of maximum current density produced in the ground plane element by the second antenna element.

10. The apparatus as claimed in claim 7, wherein the first end of the second transmission line is positioned to achieve a desired position for the second end of the second transmission line and a desired length for the second transmission line.

11. The apparatus as claimed in claim 7, wherein the second high impedance load is an open circuit gap between the second conductor and the ground plane.

12. The apparatus as claimed in claim 6, wherein the second antenna element has a second resonant frequency that has a corresponding second resonant-wavelength and the second transmission line has a length equivalent to one quarter of the second resonant wavelength.

13. The apparatus as claimed in claim 1, wherein the first antenna element operates at a lower frequency than the second antenna element and the first antenna element and the second antenna element are positioned at opposite extremities of the ground plane.

14. The apparatus as claimed in claim 1, wherein the first transmission line is formed by a portion of a keypad and the ground plane.

15. The apparatus as claimed in claim 1, wherein the second transmission line is formed by a portion of a display and the ground plane.

16. The apparatus as claimed in claim 1, wherein the second antenna element is positioned over the ground plane and adjacent a loudspeaker port.

17. The apparatus as claimed in claim 1, wherein the second antenna element is part of a planar inverted antenna.

18. The apparatus as claimed in claim 1, wherein the ground plane element is a PWB.

19. The apparatus as claimed in claim 1 configured as a module for a radio communications device.

20. The apparatus as claimed in claim 1 configured as a radio communications device.

21. An apparatus comprising:

a first antenna element;

a second antenna element;

a conductive element having a first region and a second region;

a first transmission line formed by a first conductor and the conductive element, arranged to affect a first maximum of current density produced at the first region of the conductive element by the first antenna element; the first transmission line comprising a first end having a low impedance load and a second end having a high impedance load; and

a second transmission line, arranged to affect a second maximum of current density produced at the second region of the conductive element by the second antenna element;

wherein the first end of the first transmission line is closer to the first antenna element than the second end of the first transmission line; and

wherein the second end of the first transmission line is positioned adjacent the region of maximum current density produced at the first region of the conductive element by the first antenna element.

22. The apparatus as claimed in claim 21, wherein the first antenna element has a first resonant frequency that has a corresponding first resonant wavelength and the first trans-

7

mission line has an electrical length that is a quarter of the first resonant wavelength and the second antenna element has a second resonant frequency that has a corresponding second resonant wavelength and the second transmission line has an electrical length that is a quarter of the second resonant wavelength.

23. The apparatus as claimed in claim **22**, wherein the first resonant wavelength is greater than the second resonant wavelength and the second end of the first transmission line is a first distance from the first antenna element and a second end of the second transmission line, adjacent the second region, is a second distance from the second antenna element, wherein the first distance is greater than the second distance.

24. A method comprising:

Suppressing, using a first transmission line comprising a first end having a first low impedance load and a second end, electric current, at a resonant frequency of a first antenna element, at a first region of an apparatus,

wherein the apparatus comprises the first antenna element and a second antenna element; and

suppressing electric current, at a resonant frequency of the second antenna element, at a second, different, region of the apparatus;

wherein the first end of the first transmission line is closer to the first antenna element than the second end of the first transmission line; and

wherein the second end of the first transmission line is positioned adjacent a region of maximum current density produced in a ground plane element by the first antenna element.

25. The method as claimed in claim **24** further comprising: using a second transmission line to suppress electric current at the resonant frequency of the second antenna element at the second region.

26. The method as claimed in claim **25**, wherein the second transmission line is formed by a second conductor and the ground plane.

8

27. The method as claimed in claim **26**, wherein the second antenna element has a second resonant frequency that has a corresponding second resonant wavelength and the second transmission line has a length equivalent to one quarter of the second resonant wavelength.

28. The method as claimed in claim **24**, wherein the first transmission lines is formed by a first conductor and the ground plate element.

29. The method as claimed in claim **28**, wherein the first antenna element has a first resonant frequency that has a corresponding first resonant wavelength and the first transmission line has a length equivalent to one quarter of the first resonant wavelength.

30. An apparatus comprising:

a first antenna element;

a second antenna element;

a ground plane element for at least one of the first and second antenna elements;

a first transmission line formed by a first conductor and the ground plane element arranged to affect a first maximum of current density produced in the ground plane element by the first antenna element;

wherein the first transmission line is terminated at a first end by a low impedance load and is terminated by a high impedance load at a second end; and

means for affecting a second maximum of current density produced in the ground plane element by the second antenna element;

wherein the first end of the first transmission line is closer to the first antenna element than the second end of the first transmission line; and

wherein the second end of the first transmission line is positioned adjacent the region of maximum current density produced in the ground plane element by the first antenna element.

* * * * *

UNITED STATES PATENT AND TRADEMARK OFFICE
CERTIFICATE OF CORRECTION

PATENT NO. : 8,362,957 B2
APPLICATION NO. : 12/449631
DATED : January 29, 2013
INVENTOR(S) : Antero Lehtola and Aimo Arkko

Page 1 of 1

It is certified that error appears in the above-identified patent and that said Letters Patent is hereby corrected as shown below:

In the Claims:

In column 8, line 8, "plate" should be deleted and -- plane -- should be inserted.

Signed and Sealed this
Seventh Day of May, 2013



Teresa Stanek Rea
Acting Director of the United States Patent and Trademark Office