



US008348979B2

(12) **United States Patent  
McCormack**

(10) **Patent No.: US 8,348,979 B2**  
(45) **Date of Patent: \*Jan. 8, 2013**

(54) **CERVICAL DISTRACTION METHOD**

(75) Inventor: **Bruce McCormack**, San Francisco, CA (US)

(73) Assignee: **Providence Medical Technology, Inc.**, San Francisco, CA (US)

(\* ) Notice: Subject to any disclaimer, the term of this patent is extended or adjusted under 35 U.S.C. 154(b) by 108 days.

This patent is subject to a terminal disclaimer.

5,015,247 A	5/1991	Michelson
5,026,373 A	6/1991	Ray et al.
5,100,405 A	3/1992	McLaren
5,135,528 A	8/1992	Winston
5,236,460 A	8/1993	Barber
5,484,437 A	1/1996	Michelson
5,489,307 A	2/1996	Kuslich et al.
5,505,732 A	4/1996	Michelson
5,527,312 A	6/1996	Ray
5,549,679 A	8/1996	Kuslich
5,554,191 A	9/1996	Lahille et al.
5,571,191 A	11/1996	Fitz
5,593,409 A	1/1997	Michelson
5,632,747 A	5/1997	Scarborough et al.
5,653,763 A	8/1997	Errico et al.
5,674,295 A	10/1997	Ray et al.
5,720,748 A	2/1998	Kuslich et al.

(21) Appl. No.: **12/889,122**

(22) Filed: **Sep. 23, 2010**

(65) **Prior Publication Data**

US 2011/0009968 A1 Jan. 13, 2011

**Related U.S. Application Data**

(60) Continuation of application No. 12/110,548, filed on Apr. 28, 2008, now Pat. No. 7,824,431, which is a division of application No. 11/618,619, filed on Dec. 29, 2006, now abandoned.

(51) **Int. Cl.**  
*A61B 17/88* (2006.01)

(52) **U.S. Cl.** ..... **606/279**

(58) **Field of Classification Search** ..... 606/279;  
623/17.11-17.16

See application file for complete search history.

(56) **References Cited**

U.S. PATENT DOCUMENTS

4,479,491 A	10/1984	Martin
4,530,355 A	7/1985	Griggs
4,772,287 A	9/1988	Ray et al.

FOREIGN PATENT DOCUMENTS

DE G93 04 368 5/2003  
(Continued)

OTHER PUBLICATIONS

US 7,063,700 B2 Jun. 20, 2006 Michelson (withdrawn).

(Continued)

*Primary Examiner* — Anu Ramana

(74) *Attorney, Agent, or Firm* — Polsinelli Shughart PC

(57) **ABSTRACT**

A device and method for a minimally invasive surgical implantation to reduce radicular symptoms by inserting an expandable cervical distraction implant in the facet joint and distracting the adjacent cervical vertebrae to increase the foraminal dimension. The implant, when positioned in the cervical facet joint, expands to via delivery of an inflation medium to increase the space between the vertebrae, thereby increasing the foraminal area or dimension, and reducing pressure on the nerves and blood vessels of the cervical spine.

**20 Claims, 4 Drawing Sheets**

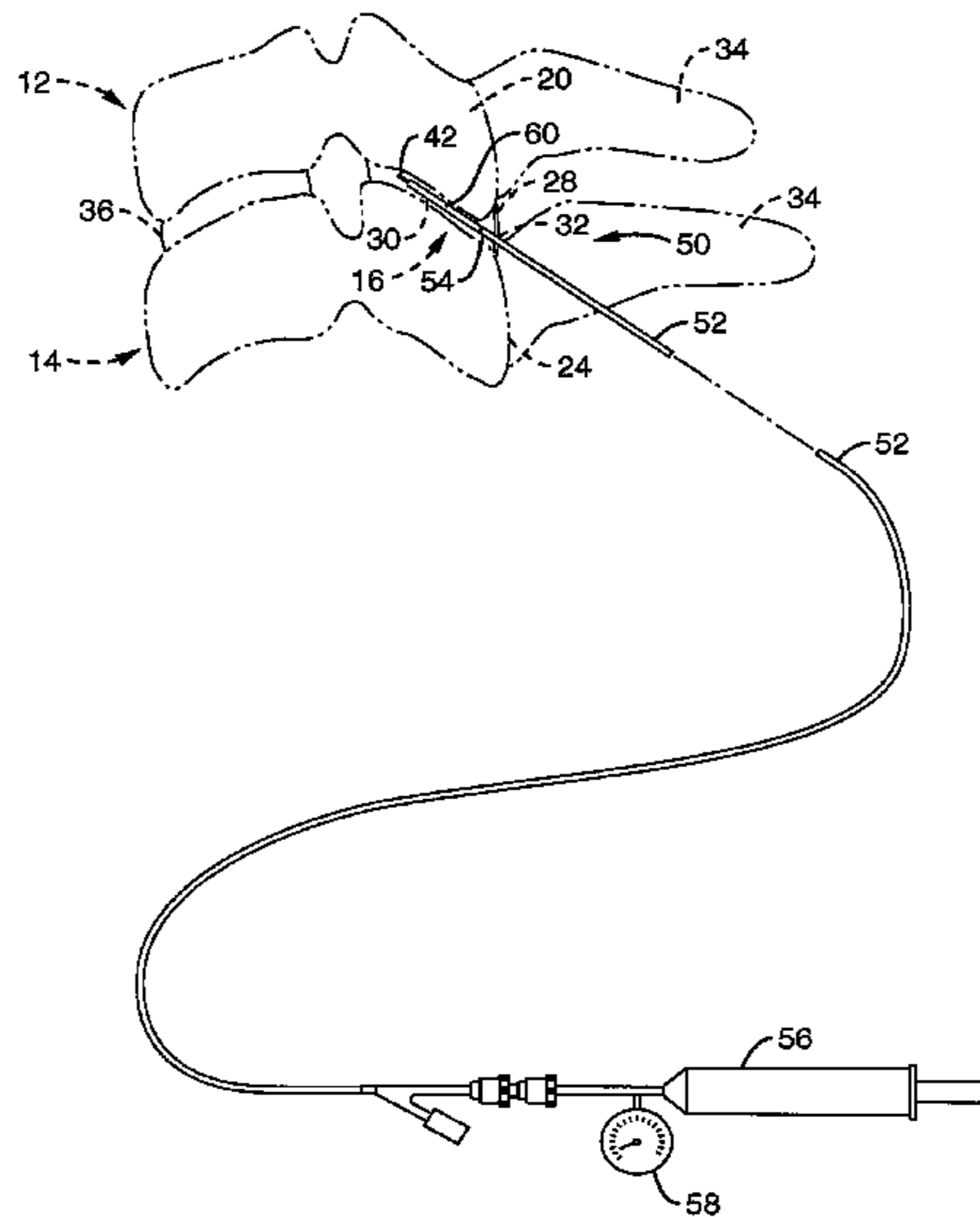

U.S. PATENT DOCUMENTS							
5,741,253	A	4/1998	Michelson	6,899,719	B2	5/2005	Reiley et al.
5,772,661	A	6/1998	Michelson	6,921,403	B2	7/2005	Cragg et al.
5,797,909	A	8/1998	Michelson	6,923,813	B2	8/2005	Phillips et al.
5,836,948	A	11/1998	Zucherman et al.	6,958,077	B2	10/2005	Suddaby
5,879,353	A	3/1999	Terry	6,962,606	B2	11/2005	Michelson
5,885,299	A	3/1999	Winslow et al.	6,966,930	B2	11/2005	Arnin et al.
5,891,147	A	4/1999	Moskovitz et al.	6,972,035	B2	12/2005	Michelson
5,895,426	A	4/1999	Scarborough et al.	6,979,333	B2	12/2005	Hammerslag
5,899,908	A	5/1999	Kuslich et al.	7,001,385	B2	2/2006	Bonutti
5,928,238	A	7/1999	Scarborough et al.	7,008,453	B1	3/2006	Michelson
5,961,522	A	10/1999	Mehdizadeh	7,033,362	B2	4/2006	McGahan et al.
5,976,146	A	11/1999	Ogawa et al.	7,033,392	B2	4/2006	Schmiel et al.
6,033,405	A	3/2000	Winslow et al.	7,033,394	B2	4/2006	Michelson
6,045,580	A	4/2000	Scarborough et al.	7,066,961	B2	6/2006	Michelson
6,063,088	A	5/2000	Winslow	7,083,623	B2	8/2006	Michelson
RE36,758	E	6/2000	Fitz	7,101,398	B2	9/2006	Dooris et al.
6,080,155	A	6/2000	Michelson	7,115,128	B2	10/2006	Michelson
6,090,143	A	7/2000	Meriwether et al.	7,118,598	B2	10/2006	Michelson
6,096,038	A	8/2000	Michelson	7,128,760	B2	10/2006	Michelson
6,099,531	A	8/2000	Bonutti	7,156,877	B2	1/2007	Lotz et al.
6,102,950	A	8/2000	Vaccaro	7,166,110	B2	1/2007	Yundt
6,149,650	A	11/2000	Michelson	7,207,991	B2	4/2007	Michelson
RE37,005	E	12/2000	Michelson et al.	7,264,622	B2	9/2007	Michelson
6,159,245	A	12/2000	Meriwether et al.	7,273,498	B2	9/2007	Bianchi et al.
6,190,388	B1	2/2001	Michelson et al.	7,288,093	B2	10/2007	Michelson
6,190,414	B1	2/2001	Young et al.	7,291,149	B1	11/2007	Michelson
6,210,412	B1	4/2001	Michelson	7,300,440	B2	11/2007	Zdeblick et al.
RE37,161	E	5/2001	Michelson et al.	7,326,211	B2	2/2008	Padget et al.
6,224,595	B1	5/2001	Michelson	7,326,214	B2	2/2008	Michelson
6,224,607	B1	5/2001	Michelson	7,371,238	B2	5/2008	Soboleski et al.
6,224,630	B1	5/2001	Bao et al.	7,399,303	B2	7/2008	Michelson
6,248,110	B1	6/2001	Reiley et al.	7,410,501	B2	8/2008	Michelson
6,264,656	B1	7/2001	Michelson	7,431,722	B1	10/2008	Michelson
6,267,763	B1	7/2001	Castro	7,445,636	B2	11/2008	Michelson
6,270,498	B1	8/2001	Michelson	7,452,359	B1	11/2008	Michelson
6,283,966	B1	9/2001	Houfburg	7,452,369	B2	11/2008	Barry
6,315,795	B1	11/2001	Scarborough et al.	7,465,304	B1	12/2008	Haufe et al.
6,402,784	B1	6/2002	Wardlaw	7,476,226	B2	1/2009	Weikel et al.
6,423,063	B1	7/2002	Bonutti	7,476,251	B2	1/2009	Zucherman et al.
6,423,083	B2	7/2002	Reiley et al.	7,479,160	B2	1/2009	Branch et al.
6,425,919	B1	7/2002	Lambrecht	7,491,205	B1	2/2009	Michelson
6,436,098	B1	8/2002	Michelson	7,500,992	B2	3/2009	Li
6,436,142	B1	8/2002	Paes et al.	7,517,358	B2	4/2009	Petersen
6,443,988	B2	9/2002	Felt et al.	7,524,333	B2	4/2009	Lambrecht et al.
6,451,023	B1	9/2002	Salazar et al.	7,569,054	B2	8/2009	Michelson
6,454,807	B1	9/2002	Jackson	7,569,057	B2	8/2009	Liu et al.
6,478,796	B2	11/2002	Zucherman et al.	7,580,743	B2	8/2009	Bourlion et al.
6,500,206	B1	12/2002	Bryan	7,591,851	B2	9/2009	Winslow et al.
6,514,256	B2	2/2003	Zucherman et al.	7,601,170	B2	10/2009	Winslow et al.
6,565,574	B2	5/2003	Michelson	7,608,077	B2	10/2009	Cragg et al.
6,569,186	B1	5/2003	Winters et al.	7,608,107	B2	10/2009	Michelson
6,575,919	B1	6/2003	Reiley et al.	7,641,664	B2	1/2010	Pagano
6,579,319	B2	6/2003	Goble et al.	7,648,523	B2	1/2010	Mirkovic et al.
6,582,432	B1	6/2003	Michelson	7,655,027	B2	2/2010	Michelson
6,607,530	B1	8/2003	Carl et al.	7,662,173	B2	2/2010	Cragg et al.
6,610,091	B1	8/2003	Reiley	7,682,378	B2	3/2010	Truckai et al.
6,626,905	B1	9/2003	Schmiel et al.	7,686,805	B2	3/2010	Michelson
6,632,235	B2	10/2003	Weikel et al.	7,686,807	B2	3/2010	Padget et al.
6,635,060	B2	10/2003	Hanson et al.	7,699,878	B2	4/2010	Pavlov et al.
6,641,582	B1	11/2003	Hanson et al.	7,708,761	B2	5/2010	Petersen
6,648,893	B2	11/2003	Dudasik	7,722,619	B2	5/2010	Michelson
6,652,584	B2	11/2003	Michelson	7,763,024	B2	7/2010	Bertagnoli et al.
6,663,647	B2	12/2003	Reiley et al.	7,763,050	B2	7/2010	Winslow et al.
6,666,866	B2	12/2003	Martz et al.	7,776,090	B2	8/2010	Winslow et al.
6,679,886	B2	1/2004	Weikel et al.	7,776,090	B2	8/2010	Winslow et al.
6,682,535	B2	1/2004	Hoogland	7,789,898	B2	9/2010	Peterman
6,685,742	B1	2/2004	Jackson	7,824,431	B2	11/2010	McCormack
6,709,458	B2	3/2004	Michelson	7,850,733	B2	12/2010	Baynham et al.
6,712,853	B2	3/2004	Kuslich	7,879,098	B1	2/2011	Simmons
6,719,773	B1	4/2004	Boucher et al.	8,162,981	B2	4/2012	Vestgaarden
6,723,095	B2	4/2004	Hammerslag	8,267,966	B2	9/2012	McCormack et al.
6,733,534	B2	5/2004	Sherman	2002/0026195	A1	2/2002	Layne et al.
6,740,093	B2	5/2004	Hochschuler et al.	2002/0107519	A1	8/2002	Dixon
6,770,074	B2	8/2004	Michelson	2002/0143343	A1	10/2002	Castro
6,793,679	B2	9/2004	Michelson	2002/0147496	A1	10/2002	Belef et al.
6,805,715	B2	10/2004	Reuter et al.	2002/0147497	A1	10/2002	Belef et al.
6,808,537	B2	10/2004	Michelson	2002/0165612	A1	11/2002	Gerber et al.
6,875,213	B2	4/2005	Michelson	2002/0169471	A1	11/2002	Ferdinand
				2003/0028251	A1	2/2003	Mathews
				2003/0139816	A1	7/2003	Michelson

2003/0158553	A1	8/2003	Michelson	2007/0135814	A1	6/2007	Farris
2004/0059337	A1	3/2004	Hanson et al.	2007/0135921	A1	6/2007	Park
2004/0073217	A1	4/2004	Michelson	2007/0149976	A1	6/2007	Hale et al.
2004/0087948	A1	5/2004	Suddaby	2007/0149983	A1	6/2007	Link
2004/0087956	A1	5/2004	Weikel et al.	2007/0150061	A1	6/2007	Trieu
2004/0106999	A1	6/2004	Mathews	2007/0161991	A1	7/2007	Altarac et al.
2004/0133277	A1	7/2004	Michelson	2007/0179617	A1	8/2007	Brown et al.
2004/0133280	A1	7/2004	Trieu	2007/0179619	A1	8/2007	Grob et al.
2004/0162562	A1	8/2004	Martz	2007/0225721	A1	9/2007	Thelen et al.
2004/0215344	A1	10/2004	Hochschuler et al.	2007/0244483	A9	10/2007	Winslow et al.
2005/0010294	A1	1/2005	Michelson	2007/0276491	A1	11/2007	Ahrens
2005/0015149	A1	1/2005	Michelson	2007/0288014	A1*	12/2007	Shadduck et al. .... 606/61
2005/0049705	A1	3/2005	Hale et al.	2007/0299451	A1	12/2007	Tulkis
2005/0055096	A1	3/2005	Serhan et al.	2008/0021457	A1	1/2008	Anderson et al.
2005/0065518	A1	3/2005	Michelson	2008/0108996	A1	5/2008	Padget et al.
2005/0065519	A1	3/2005	Michelson	2008/0140207	A1	6/2008	Olmos et al.
2005/0065608	A1	3/2005	Michelson	2008/0161810	A1	7/2008	Melkent
2005/0065609	A1	3/2005	Wardlaw	2008/0161929	A1	7/2008	McCormack et al.
2005/0080422	A1	4/2005	Otte et al.	2008/0167657	A1	7/2008	Greenhalgh
2005/0090829	A1	4/2005	Martz et al.	2008/0177311	A1	7/2008	Winslow et al.
2005/0090901	A1	4/2005	Studer	2008/0208341	A1	8/2008	McCormack et al.
2005/0119680	A1	6/2005	Dykes	2008/0234758	A1	9/2008	Fisher et al.
2005/0124993	A1	6/2005	Chappuis	2008/0255564	A1	10/2008	Michelson
2005/0159650	A1	7/2005	Raymond et al.	2008/0255618	A1	10/2008	Fisher et al.
2005/0159746	A1	7/2005	Grob et al.	2008/0255622	A1	10/2008	Mickiewicz et al.
2005/0177240	A1	8/2005	Blain	2008/0255666	A1	10/2008	Fisher et al.
2005/0216018	A1	9/2005	Sennett	2008/0255667	A1	10/2008	Horton
2005/0240188	A1	10/2005	Chow et al.	2008/0287955	A1	11/2008	Michelson
2005/0251146	A1	11/2005	Martz et al.	2008/0312744	A1	12/2008	Vresilovic et al.
2005/0251257	A1	11/2005	Mitchell et al.	2009/0131986	A1	5/2009	Lee et al.
2005/0267480	A1	12/2005	Suddaby	2009/0138053	A1	5/2009	Assell et al.
2006/0004367	A1	1/2006	Alamin et al.	2009/0177205	A1	7/2009	McCormack et al.
2006/0036243	A1	2/2006	Sasso et al.	2009/0234397	A1	9/2009	Petersen
2006/0036247	A1	2/2006	Michelson	2009/0306671	A1	12/2009	McCormack et al.
2006/0036323	A1	2/2006	Carl et al.	2009/0312763	A1	12/2009	McCormack et al.
2006/0041311	A1	2/2006	McLeer	2010/0069912	A1	3/2010	McCormack et al.
2006/0058793	A1	3/2006	Michelson	2010/0086185	A1	4/2010	Weiss
2006/0058878	A1	3/2006	Michelson	2010/0093829	A1	4/2010	Gorman
2006/0069442	A1	3/2006	Michelson	2010/0191241	A1	7/2010	McCormack et al.
2006/0079905	A1	4/2006	Beyar et al.	2011/0022089	A1	1/2011	Assell et al.
2006/0079962	A1	4/2006	Michelson	2011/0082548	A1	4/2011	Assell et al.
2006/0085074	A1	4/2006	Raiszadeh				
2006/0095028	A1	5/2006	Bleich				
2006/0095036	A1	5/2006	Hammerslag				
2006/0111779	A1	5/2006	Peterson				
2006/0111780	A1	5/2006	Petersen				
2006/0142762	A1	6/2006	Michelson				
2006/0149254	A1	7/2006	Laurysen et al.				
2006/0149289	A1	7/2006	Winslow et al.				
2006/0184172	A1	8/2006	Michelson				
2006/0190081	A1	8/2006	Kraus et al.				
2006/0195109	A1	8/2006	McGahan et al.				
2006/0200137	A1	9/2006	Soboleski et al.				
2006/0200138	A1	9/2006	Michelson				
2006/0200139	A1	9/2006	Michelson				
2006/0206118	A1	9/2006	Kim et al.				
2006/0235391	A1	10/2006	Sutterlin, III				
2006/0241597	A1	10/2006	Mitchell et al.				
2006/0241626	A1	10/2006	McGahan et al.				
2006/0241758	A1	10/2006	Peterman et al.				
2006/0247632	A1	11/2006	Winslow et al.				
2006/0247633	A1	11/2006	Winslow et al.				
2006/0247650	A1	11/2006	Yerby et al.				
2006/0259142	A1	11/2006	Dooris et al.				
2006/0271195	A1	11/2006	Thramann				
2006/0276790	A1	12/2006	Dawson et al.				
2006/0276801	A1	12/2006	Yerby et al.				
2006/0276897	A1	12/2006	Winslow et al.				
2007/0016195	A1	1/2007	Winslow et al.				
2007/0016196	A1	1/2007	Winslow et al.				
2007/0016218	A1	1/2007	Winslow et al.				
2007/0032871	A1	2/2007	Michelson				
2007/0043362	A1	2/2007	Malandain et al.				
2007/0055245	A1	3/2007	Sasso et al.				
2007/0055263	A1	3/2007	Way et al.				
2007/0073402	A1	3/2007	Vresilovic et al.				
2007/0083265	A1	4/2007	Malone				
2007/0123863	A1	5/2007	Winslow et al.				
2007/0123888	A1	5/2007	Bleich et al.				

FOREIGN PATENT DOCUMENTS

FR	2 722 980	A1	2/1996
WO	WO 99/49818	A1	10/1999
WO	WO 00/35388	A1	6/2000
WO	WO 00/53126	A1	9/2000
WO	WO 01/01895	A1	1/2001
WO	WO 02/34120	A2	5/2002
WO	WO 02/38062	A2	5/2002
WO	WO 02/076335	A2	10/2002
WO	WO 2006/058221	A2	6/2006
WO	WO 2006/130791	A2	12/2006
WO	WO 2008/083349	A2	7/2008
WO	WO 2009/089367	A2	7/2009
WO	WO 2009/148619	A2	12/2009
WO	WO 2010/030994	A2	3/2010
WO	WO 2010/074714	A2	7/2010

OTHER PUBLICATIONS

Amendment and Response to Office Action, U.S. Appl. No. 12/110,548, filed May 5, 2009, 11 pages.  
 Amendment, U.S. Appl. No. 11/618,619, filed May 5, 2008, 10 pages.  
 Final OA, U.S. Appl. No. 12/110,548, mailed Feb. 26, 2010, 4 pages.  
 Final Office Action, U.S. Appl. No. 11/618,619, mailed Aug. 8, 2008, 10 pages.  
 International Search Report and WO, International patent application No. PCT/US2009/056841, dated Apr. 9, 2010 (P190651/PCT).  
 International Search Report and WO, PCT/US2009/006478, dated Jun. 29, 2010.  
 International Search Report and Written Opinion, International patent application No. PCT/US07/89146 Nov. 3, 2008.  
 International Search Report and Written Opinion, International patent application No. PCT/US2009/030461, dated Aug. 17, 2009.  
 International Search Report and Written Opinion, International patent application No. PCT/US2009/003423, dated Dec. 14, 2009.

- Interview summary, U.S. Appl. No. 11/618,619, mailed Mar. 18, 2008, 3 pages.
- Non-Final Office Action and PTO-892, U.S. Appl. No. 11/618,619, mailed Jan. 3, 2008, 12 pages.
- Non-Final Office Action and PTO-892, U.S. Appl. No. 12/110,548, mailed Feb. 17, 2009, 11 pages.
- Notice of Allowance, U.S. Appl. No. 12/110,548, mailed Mar. 29, 2010, 5 pages.
- Notice of Allowance, U.S. Appl. No. 12/110,548, mailed Jul. 14, 2010 (10 pages).
- Partial International Search Report, International patent application No. PCT/US2009/030461, dated May 13, 2009.
- Partial International Search Report, International patent application No. PCT/US2009/003423, dated Sep. 14, 2009.
- Partial International Search Report, International patent application No. PCT/US2009/056841, dated Dec. 10, 2009.
- Partial International Search Report, International patent application No. PCT/US2009/006478, dated Apr. 7, 2010.
- Press Release , Interventional Spine, Inc., FDA Grants Conditional Approval to Interventional Spine's PercuDyn System IDE Application (Jul. 1, 2008).
- Press Release , Interventional Spine, Inc., Interventional Spine, Inc. Introduces the PERPOS Fusion Facet Prep Kit (Oct. 14, 2008).
- Press Release, minSURG Corp., Orthopedic Development Corporation's TruFUSE Procedure Tops 1,750 Patients in First Year (Sep. 24, 2007).
- Non-final Office Action, U.S. Appl. No. 12/350,609, dated Oct. 18, 2011, 27 pages.
- Office Action (Quayle), U.S. Appl. No. 12/653,283, dated Dec. 22, 2011, 8 pages.
- Response to Non-Final Office Action, U.S. Appl. No. 12/317,682, filed Dec. 13, 2011, 19 pages.
- Response to Non-Final Office Action, U.S. Appl. No. 12/653,283, filed Dec. 6, 2011, 14 pages.
- Corrected Response to Restriction Requirement, U.S. Appl. No. 12/317,682, filed Sep. 2, 2011, 15 pages.
- Goel, Atul et al., Facetal Distraction as Treatment for Single- and Multilevel Cervical spondylotic Radiculopathy and Myelopathy: A Preliminary Report. *J Neurosurg Spine* 14:689-696, Jun. 2011; published online Mar. 18, 2011; DOI: 10.3171/2011.2.SPINE10601.
- Nonfinal Office Action, U.S. Appl. No. 12/317,682, dated Sep. 15, 2011, 25 pages.
- Nonfinal Office Action, U.S. Appl. No. 12/653,283, dated Aug. 9, 2011, 20 pages.
- Notice of Non-Responsive Amendment, U.S. Appl. No. 12/317,682, dated Aug. 8, 2011, 2 pages.
- Office Action (Restriction), U.S. Appl. No. 12/317,682, dated Apr. 22, 2011, 14 pages.
- Office Action (Restriction), U.S. Appl. No. 12/350,609, dated Jun. 14, 2011, 6 pages.
- Office Action (Restriction), U.S. Appl. No. 12/455,814, dated Apr. 20, 2011, 14 pages.
- Office Action (Restriction), U.S. Appl. No. 12/653,283, dated Jun. 24, 2011, 9 pages.
- Response to Restriction Requirement, U.S. Appl. No. 12/350,609, filed Aug. 15, 2011, 14 pages.
- Response to Restriction, U.S. Appl. No. 12/317,682, filed May 16, 2011, 15 pages.
- Response to Restriction, U.S. Appl. No. 12/455,814, filed May 16, 2011, 10 pages.
- Response to Restriction, U.S. Appl. No. 12/653,283, filed Jul. 22, 2011, 8 pages.
- Advisory Action, U.S. Appl. No. 12/317,682, dated Apr. 6, 2012, 3 pages.
- Final Office Action, U.S. Appl. No. 12/317,682, mailed Feb. 10, 2012, 8 pages.
- Final Office Action, U.S. Appl. No. 12/350,609, mailed Apr. 25, 2012, 10 pages.
- Final Office Action, U.S. Appl. No. 12/455,814, mailed Jun. 6, 2012, 12 pages.
- Final Office Action, U.S. Appl. No. 12/653,283, mailed Mar. 21, 2012, 8 pages.
- Non-Final Office Action, U.S. Appl. No. 12/653,283, mailed Feb. 10, 2012, 7 pages.
- Non-Final Office Action, U.S. Appl. No. 12/455,814, dated Jan. 24, 2012, 30 pages.
- Notice of Allowance, U.S. Appl. No. 12/317,682, mailed May 11, 2012, 10 pages.
- Response to Advisory Action, U.S. Appl. No. 12/317,682, filed Apr. 24, 2012, 4 pages.
- Response to Final Office Action, U.S. Appl. No. 12/317,682, filed Mar. 22, 2012, 17 pages.
- Response to Final Office Action, U.S. Appl. No. 12/653,283, filed Jun. 15, 2012, 7 pages.
- Response to Non-Final Office Action, U.S. Appl. No. 12/350,609, filed Feb. 17, 2012, 16 pages.
- Response to Non-Final Office Action, U.S. Appl. No. 12/455,814, filed Apr. 24, 2012, 15 pages.
- Response to Non-Final Office Action, U.S. Appl. No. 12/653,283, filed Mar. 8, 2012, 9 pages.
- Response to Quayle Action, U.S. Appl. No. 12/653,283, filed Feb. 1, 2012, 3 pages.
- Restriction Requirement, U.S. Appl. No. 12/559,193, dated Apr. 18, 2012, 10 pages.
- U.S. Appl. No. 13/614,281, filed Sep. 13, 2012, McCormack et al.
- U.S. Appl. No. 13/614,372, filed Sep. 13, 2012, McCormack et al.
- U.S. Appl. No. 13/614,508, filed Sep. 13, 2012, McCormack et al.
- U.S. Appl. No. 13/614,577, filed Sep. 13, 2012, McCormack et al.
- U.S. Appl. No. 13/627,812, filed Sep. 26, 2012, McCormack et al.
- U.S. Appl. No. 13/627,825, filed Sep. 26, 2012, McCormack et al.
- U.S. Appl. No. 13/627,850, filed Sep. 26, 2012, McCormack et al.
- U.S. Appl. No. 13/627,865, filed Sep. 26, 2012, McCormack et al.
- Advisory Action, U.S. Appl. No. 12/455,814, dated Aug. 16, 2012, 3 pages.
- Non-Final Office Action, U.S. Appl. No. 12/559,193, mailed Sep. 18, 2012, 26 pages.
- Non-Final Office Action, U.S. Appl. No. 12/653,283, mailed Jul. 18, 2012, 5 pages.
- Notice of Allowance, U.S. Appl. No. 12/455,814, mailed Oct. 2, 2012, 6 pages.
- RCE/Amendment, U.S. Appl. No. 12/350,609, filed Jul. 24, 2012, 19 pages.
- Response to Advisory Action, U.S. Appl. No. 12/455,814, filed Sep. 5, 2012, 6 pages.
- Response to Final Office Action, U.S. Appl. No. 12/455,814, filed Aug. 6, 2012, 13 pages.

\* cited by examiner

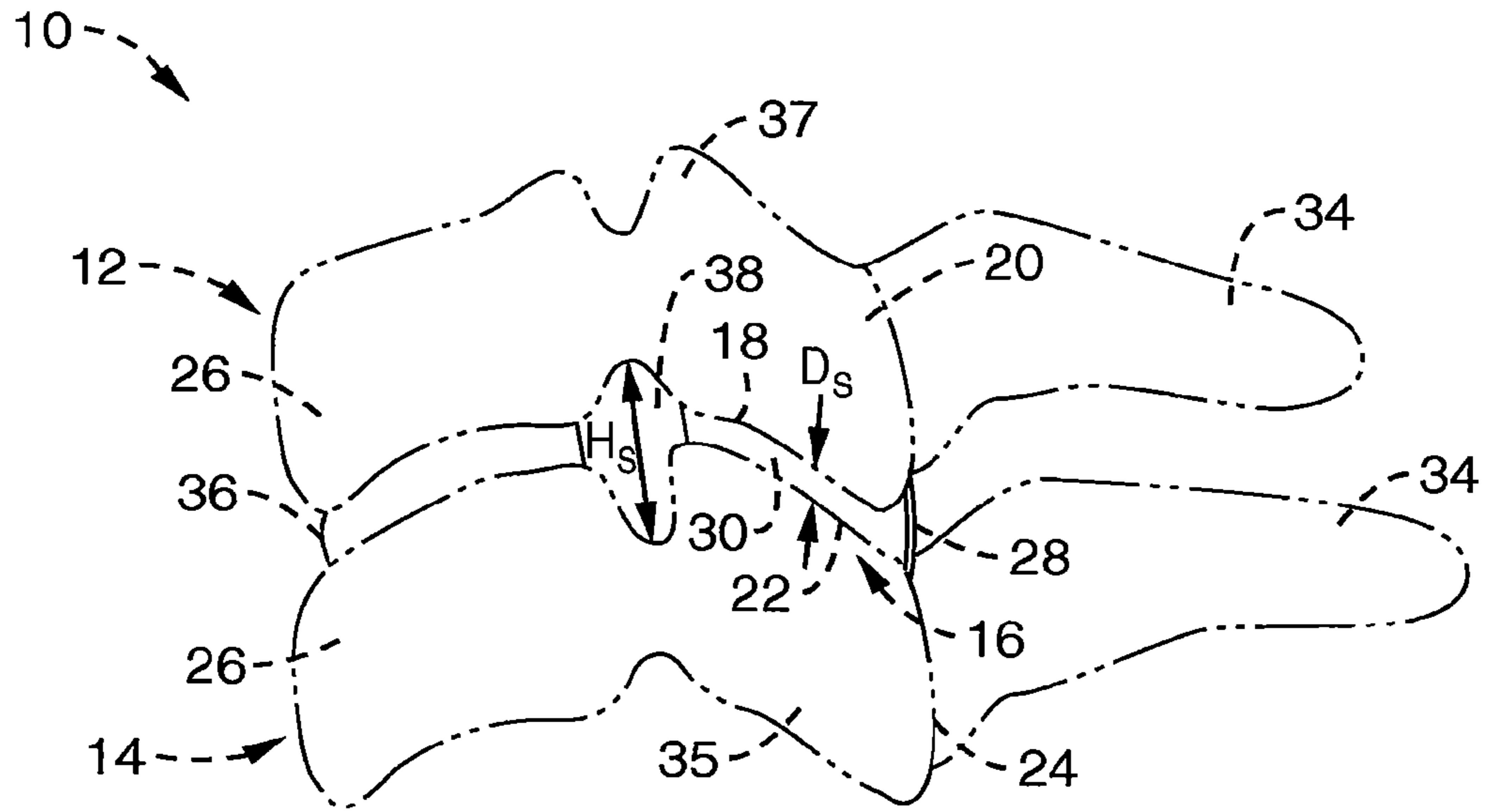

FIG. 1

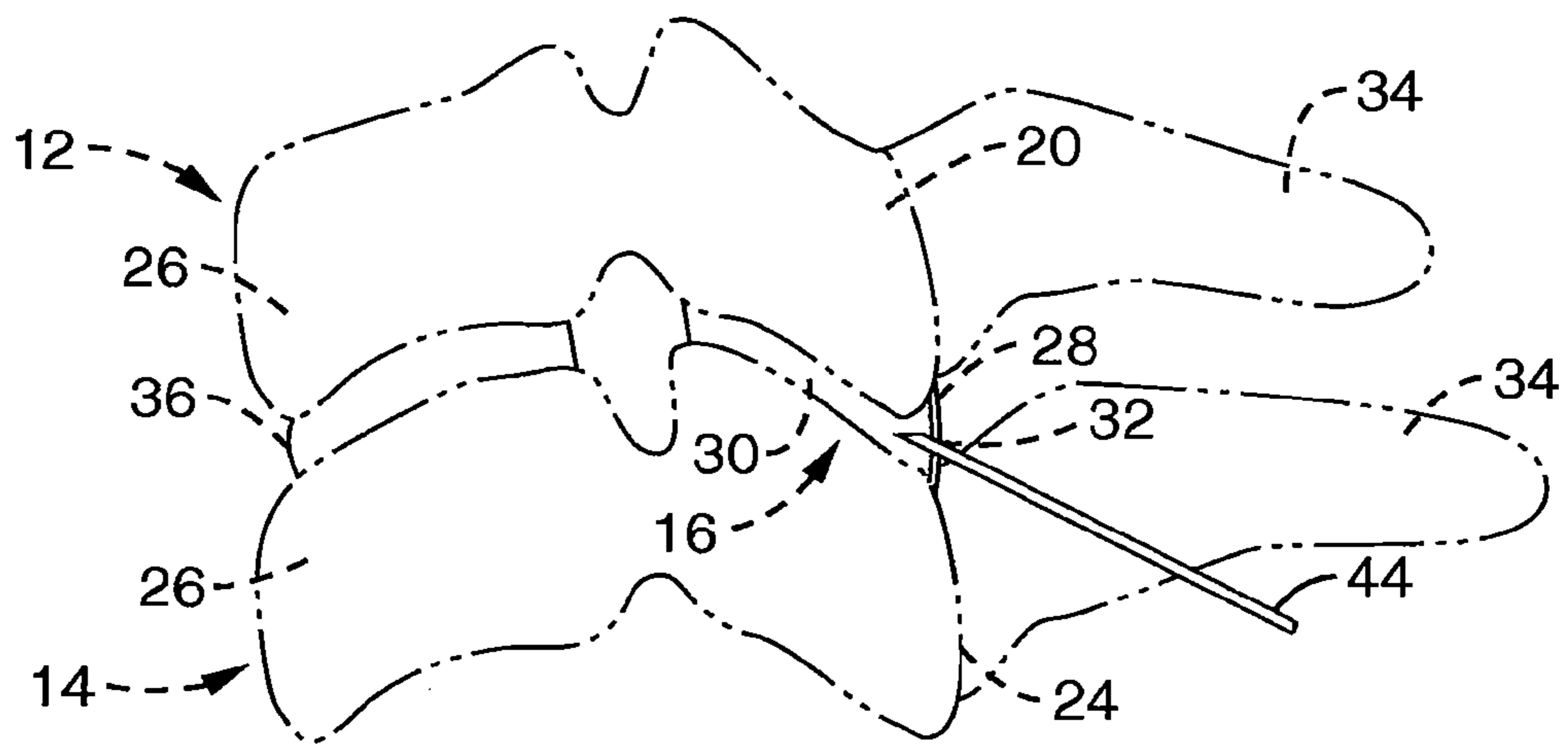

FIG. 2

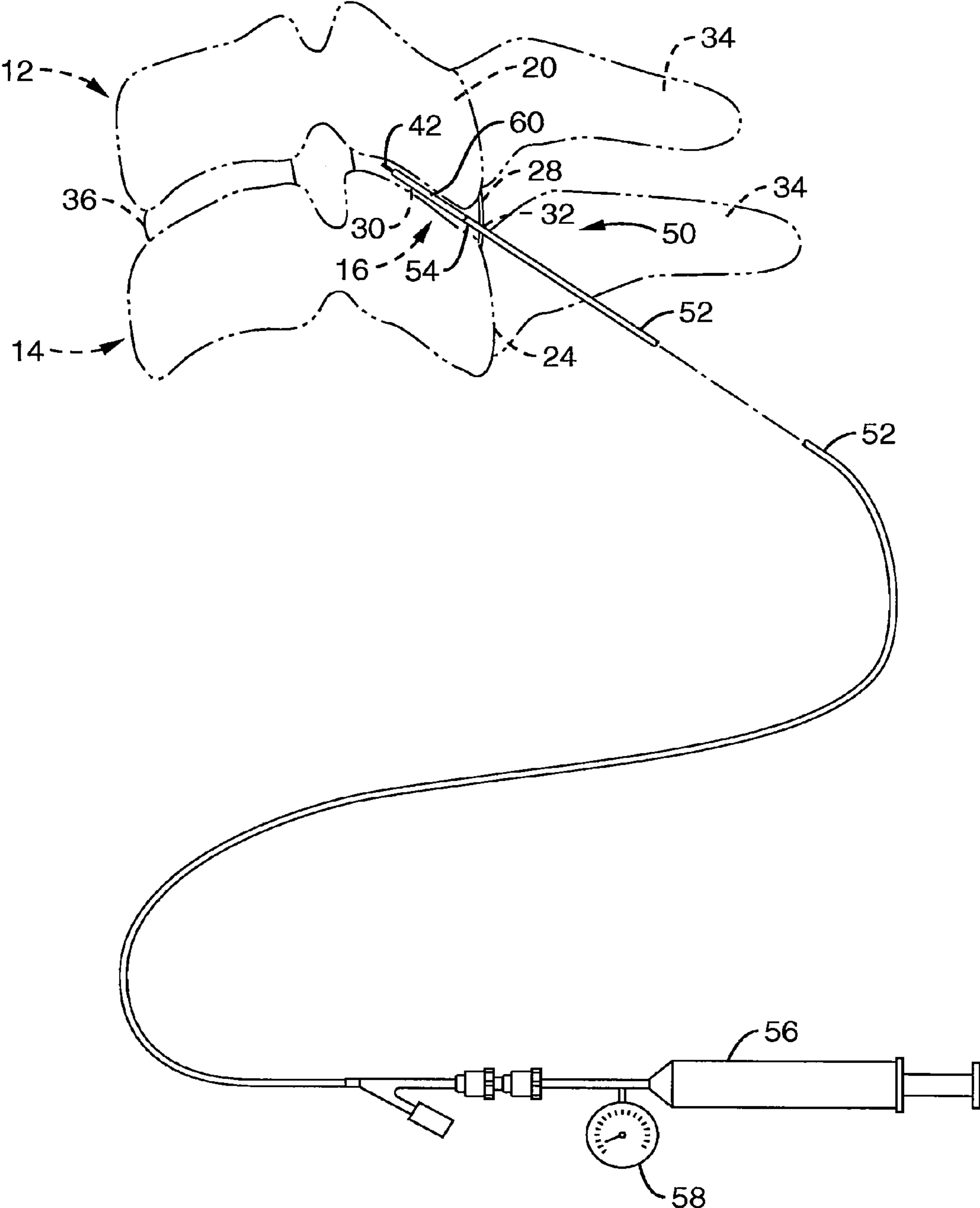
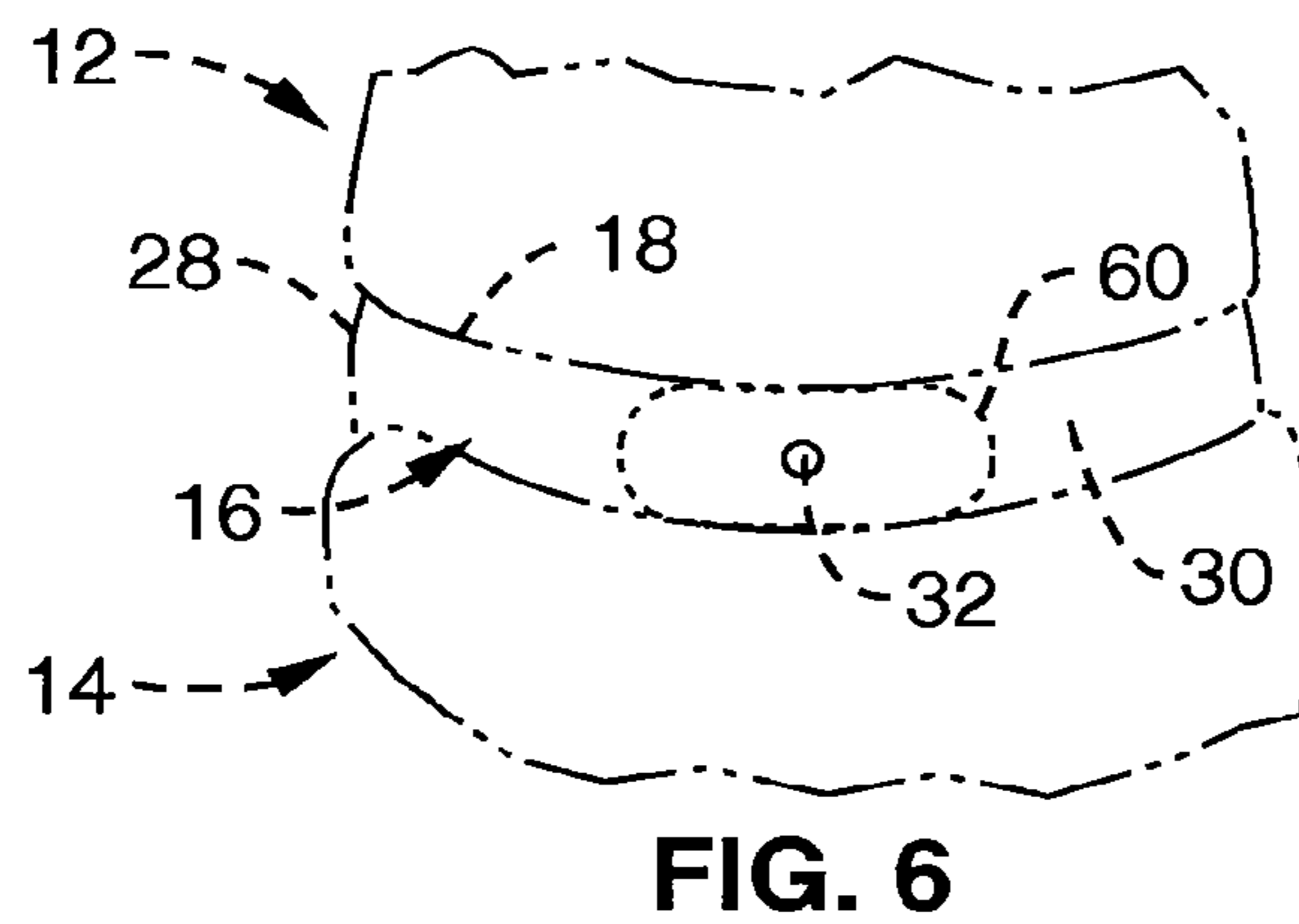
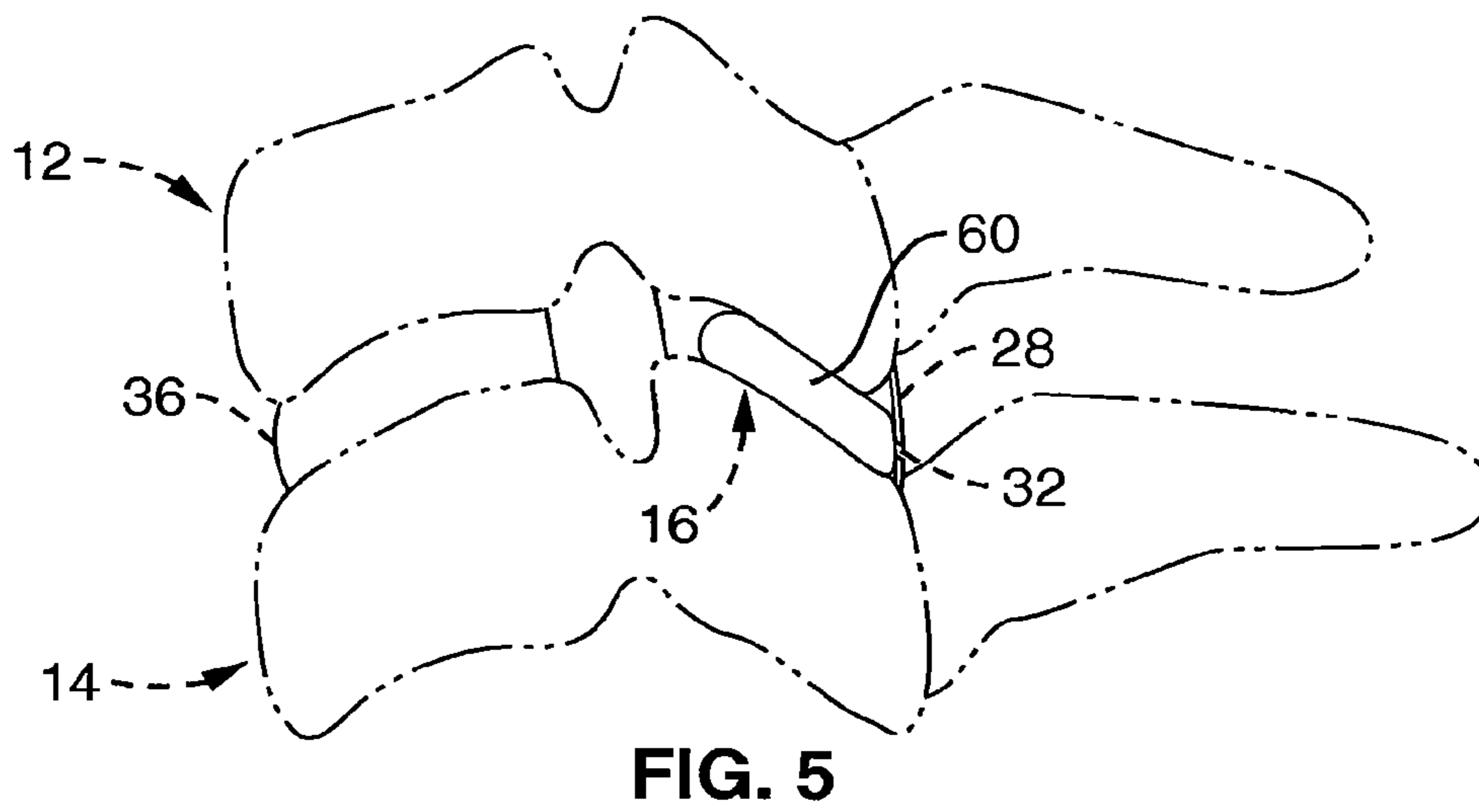
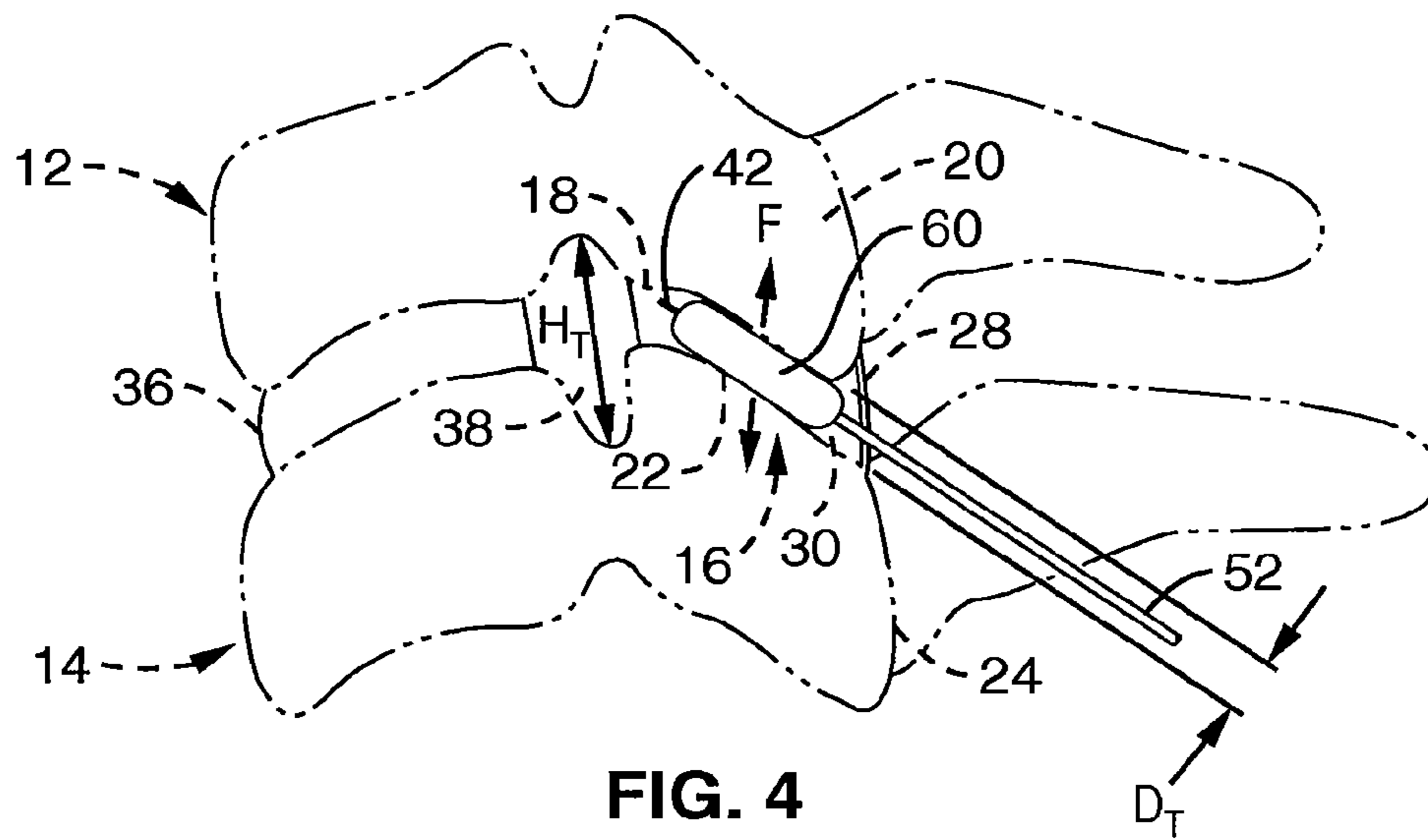

FIG. 3



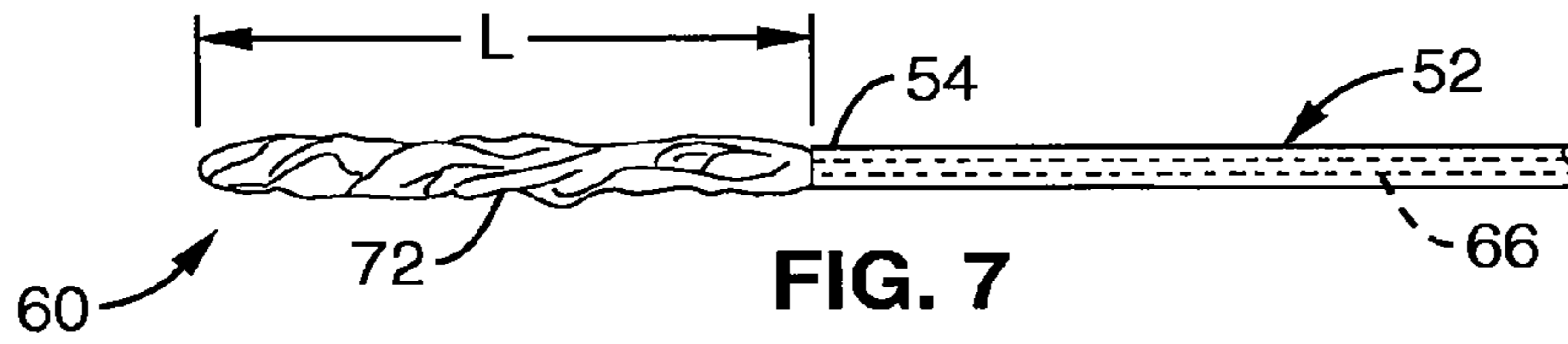

FIG. 7

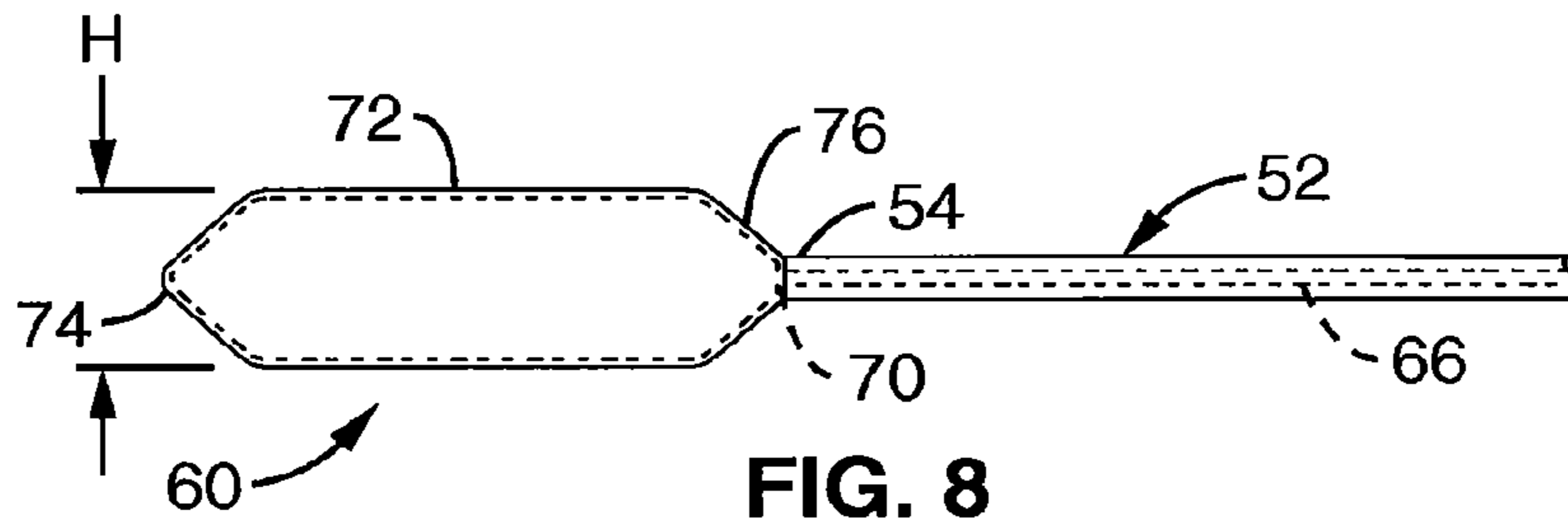

FIG. 8

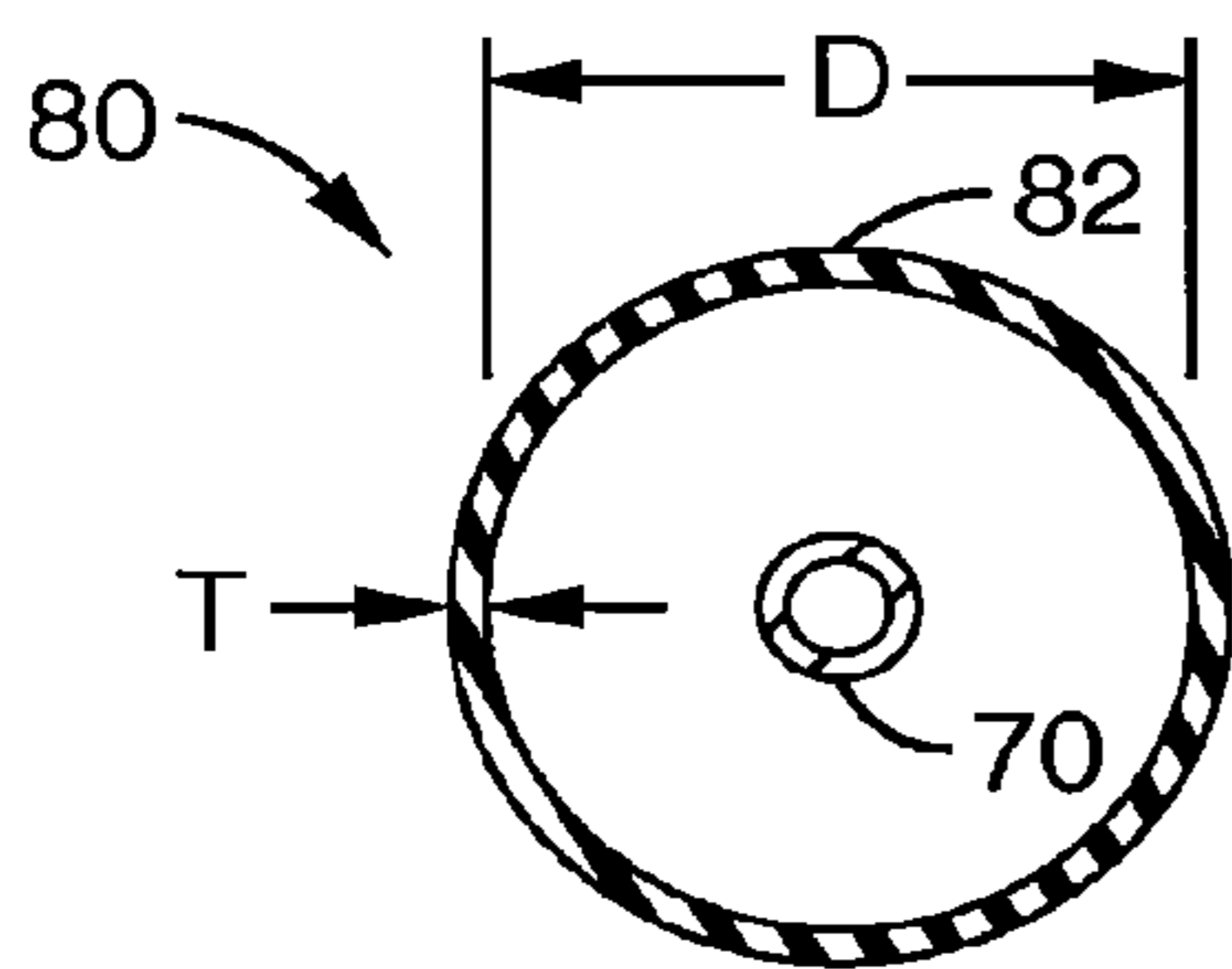

FIG. 9

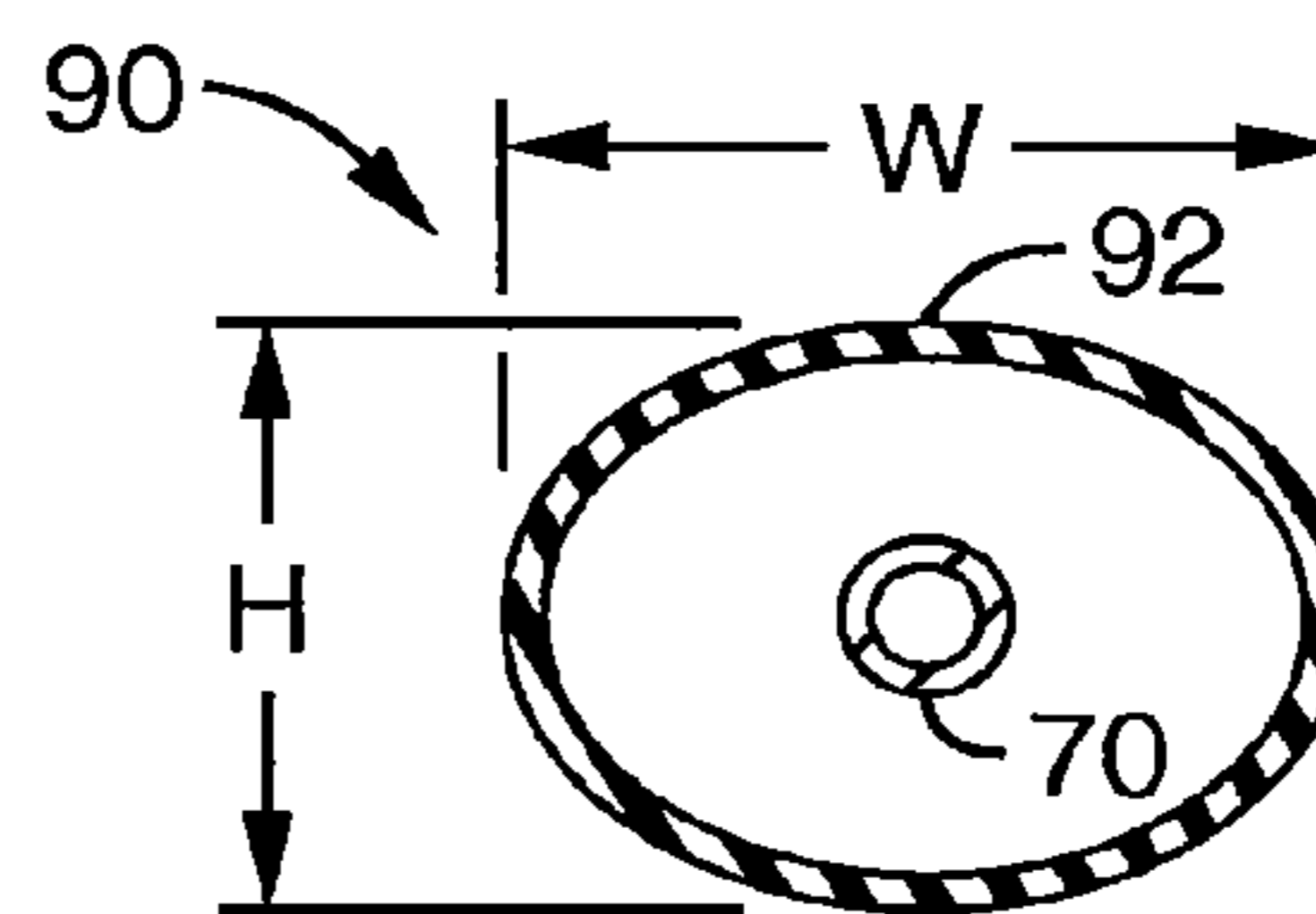

FIG. 10

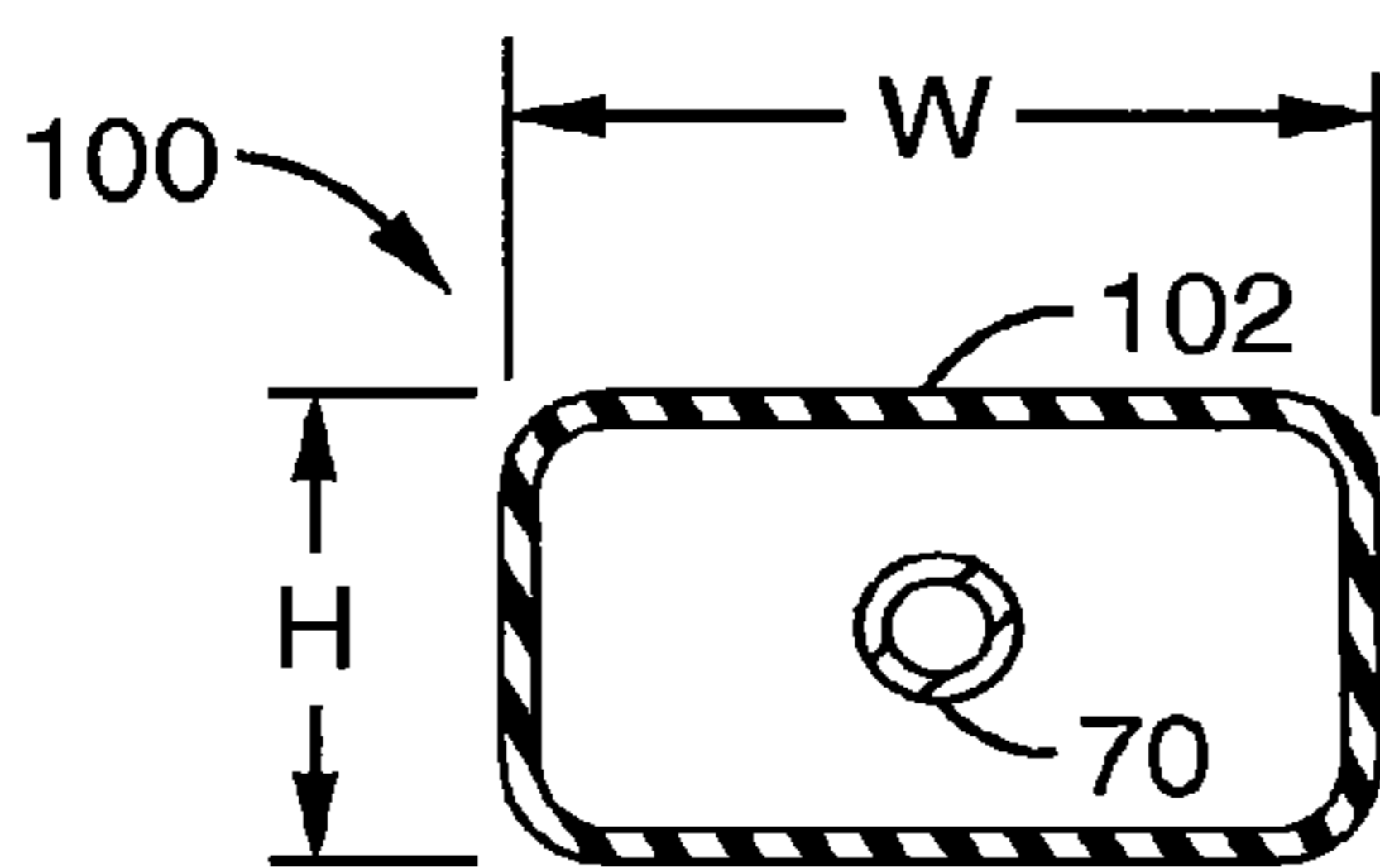

FIG. 11

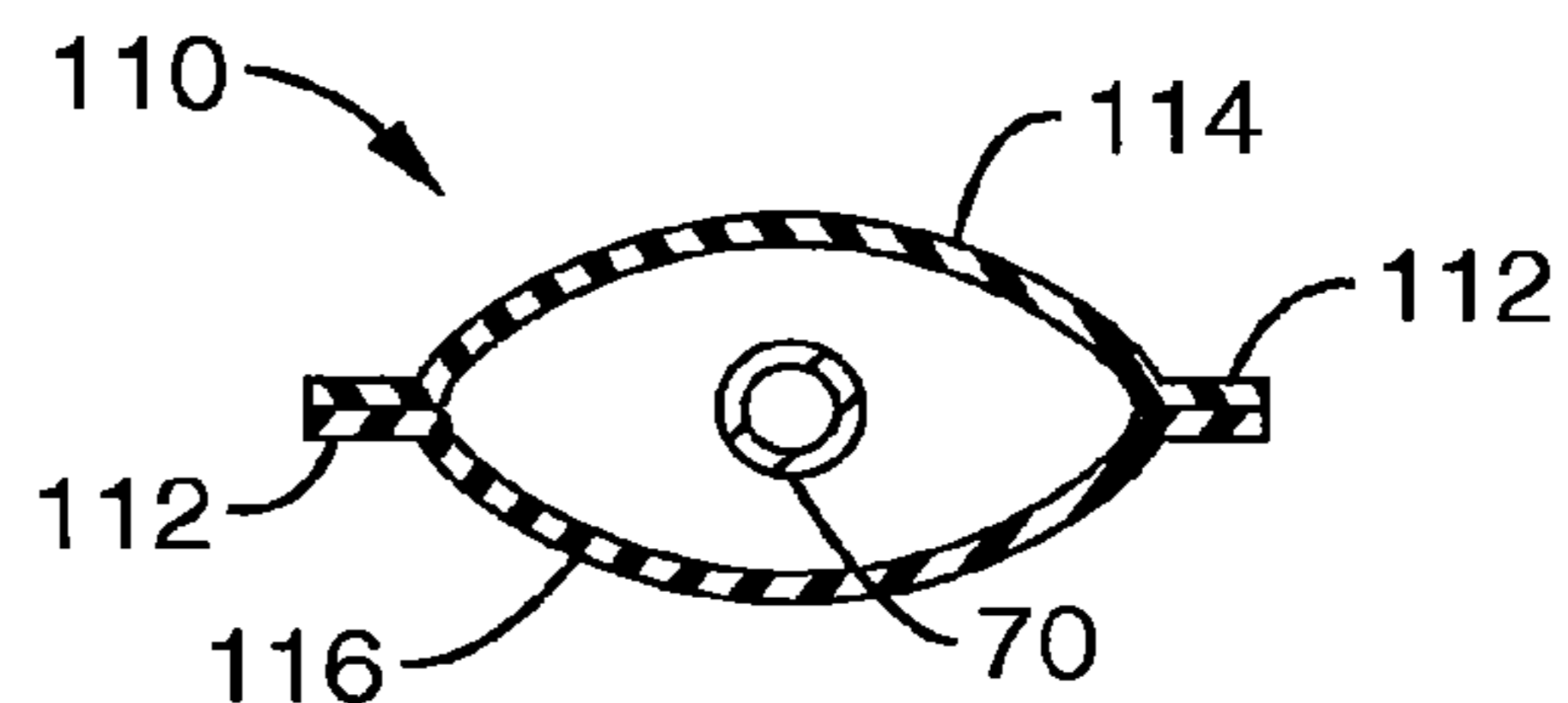

FIG. 12

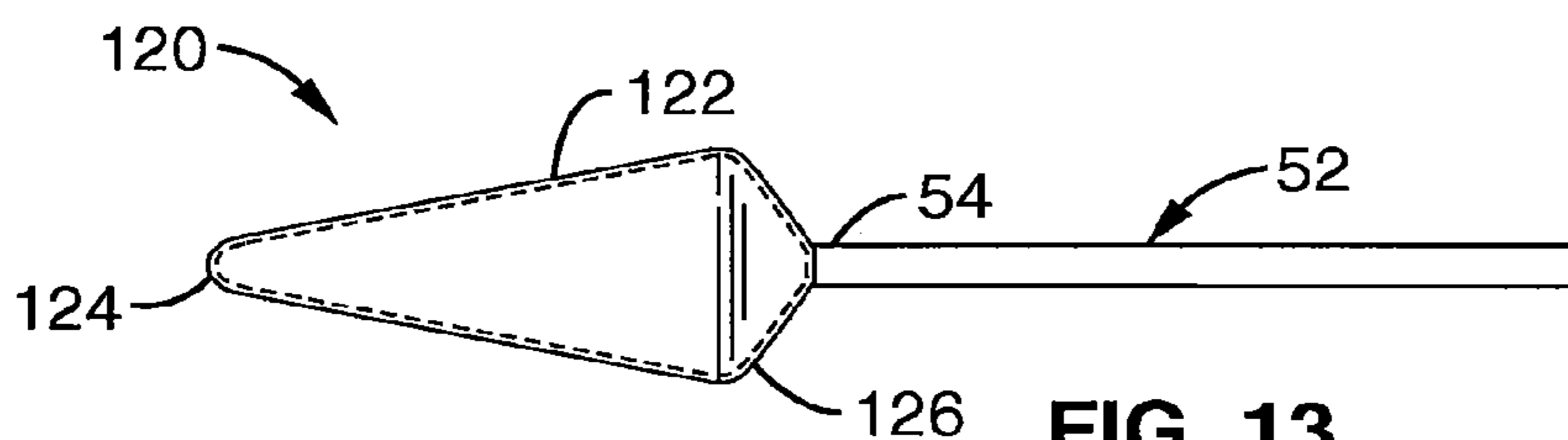

FIG. 13



**CERVICAL DISTRACTION METHOD****CROSS REFERENCE TO RELATED APPLICATION**

This application is a continuation of U.S. patent application Ser. No. 12/110,548 filed Apr. 28, 2008, now U.S. Pat. No. 7,824,431, which application is a divisional application of U.S. patent application Ser. No. 11/618,619 filed on Dec. 29, 2006, abandoned. The '548 and '619 applications are incorporated by reference into the present application in their entirety.

**BACKGROUND OF THE INVENTION****1. Field of the Invention**

This invention pertains generally to an implantable distraction device, and more particularly to a cervical distraction device.

**2. Description of the Relevant Art**

Chronic back problems cause pain and disability for a large segment of the population. Adverse spinal conditions are characteristic of age. With aging, generally comes an increase in spinal stenosis (including, but not limited to, central canal and lateral stenosis), and facet arthropathy. Spinal stenosis results in a reduction of foraminal area (i.e., the available space for the passage of nerves and blood vessels) which compresses the cervical nerve roots and causes radicular pain. Extension and ipsilateral rotation of the neck further reduces the foraminal area and contributes to pain, nerve root compression, and neural injury. However, neck flexion generally increases the foraminal area.

Cervical disc herniations predominantly present with upper extremity radicular symptoms. The vast majority of these herniations do not have an associated neurologic deficit and present with pain only. A well-described treatment for cervical disc herniations is closed traction. There are a number of marketed devices that alleviate pain by pulling on the head to increase foraminal height.

Cervical disc herniations have been treated with anterior and posterior surgery. The vast majority of these surgeries are performed through an anterior approach, which requires a spinal fusion. These surgeries are expensive and beget additional surgeries due to change in biomechanics of the neck. There is a 3% incidence of re-operation after cervical spine surgery.

Therefore, an object of the present invention is to provide a minimally invasive device and surgery to increase foraminal height reduce radicular symptoms for patients with disc herniations.

At least some of these objectives will be met in the following disclosure.

**SUMMARY OF THE INVENTION**

A device and technique are disclosed for a minimally invasive surgical implantation to reduce radicular symptoms by inserting an expandable cervical distraction implant in the facet joint at an affected level to preserve the physiology of the spine. In particular, embodiments of the present invention provide for distracting the cervical spine to increase the foraminal dimension in extension and neutral positions. The implant of the present invention, when positioned in the cervical facet joint, expands to distract, or increase the space between, the vertebrae to increase the foraminal area or dimension, and reduce pressure on the nerves and blood vessels of the cervical spine.

The procedure may be performed under conscious sedation in order to obtain intra-operative patient symptom feedback.

When the distraction implant is optimally positioned in the facet joint, it is injected with a bio-inert hydrogel using a catheter inflation syringe with pressure/volume monitor. The injection of the hydrogel causes the implant to expand in order to achieve cervical distraction. At this point in the procedure, patient feedback regarding symptom improvement could be obtained.

After achieving the desired distraction, the catheter is detached from the distraction implant and be removed. The patient is left with the distraction implant expanded in the facet joint with permanent increased foraminal height.

Aspect of the invention is an apparatus for distracting first and second adjacent vertebrae. The apparatus has an expandable implant configured to be inserted in a collapsed configuration within a facet joint bounded by the first and second vertebrae, and expand within the facet joint to increase a foraminal dimension, e.g. foraminal height associated with the first and second adjacent vertebrae.

Preferably, the expandable implant is configured to be installed in a facet joint located between at least one cervical vertebra. However, other locations are contemplated.

In one embodiment, the expandable implant is configured to engage the articulating surfaces of the facet joint to increase the distance between the articulating surfaces, the distance correlating to the foraminal dimension.

The expandable implant may comprises an inflatable balloon configured to be filled with an inflation medium, e.g. hydrogel or the like, to distribute a compressive load on the articulating surfaces.

Generally, the facet joint has a joint capsule that extends beyond the margin of the articulating surfaces. In a preferred embodiment, the expandable implant is configured to be delivered into the facet joint through an access hole created in the joint capsule. The expandable implant is ideally configured such that, in its expanded configuration, is larger than the access hole so that the expandable implant is retained in the facet joint once expanded. The expandable implant may also be configured to plug the access hole once expanded. Typically, the expandable implant is configured to occupy a substantial portion of the depth of the facet joint once expanded.

In another preferred embodiment, the expandable implant is configured to dynamically stabilize the facet joint. Generally, the expandable implant increases and maintains a minimum distance between the articulating surfaces, while allowing motion of the first vertebrae with respect to the second vertebrae.

For delivery, the expandable implant preferably attaches to a distal tip of a catheter to facilitate installation into the facet joint. The catheter transports the inflation medium into the expandable implant. The expandable implant is configured to detach from the catheter once the implant is expanded in the facet joint.

Another aspect is a method of minimally invasively distracting first and second adjacent vertebrae. The method includes the steps of inserting an expandable implant, in a collapsed state, into a facet joint bounded by the first and second vertebrae, and expanding the expandable implant within the facet joint to increase a foraminal dimension associated with the first and second vertebrae.

In a preferred embodiment, the expandable implant is installed in a facet joint located between at least one cervical vertebra. The expandable implant engages the articulating surfaces of the facet joint to increase the distance between the articulating surfaces.

3

In many embodiments, inserting an expandable implant is achieved by creating an access hole through the joint capsule, and inserting the expandable implant in a collapsed configuration through the access hole and into the facet joint. Typically, the access hole is created with an introducer needle used to deliver the expandable member.

In a preferred embodiment, an inflatable balloon is filled with an inflation medium causing the balloon to engage the articulating surfaces the expandable implant. A compressive load is imparted on the articulating surfaces to distract the first vertebra from the second vertebra.

To inflate the expandable implant, a catheter is fed through the access hole and into the facet joint with the expandable implant attached to a distal tip of a catheter. An inflation medium is then delivered into the expandable implant via the catheter to inflate expandable implant with the inflation medium. Once inflated, the expandable implant detaches from the catheter once the implant is expanded in the facet joint.

Dynamic stabilization of the facet joint is affected as a result of the expanded implant being disposed between the articulating surfaces of the facet joint. The distance between the articulating surfaces is maintained while allowing motion of the first vertebrae with respect to the second vertebrae.

In one embodiment, the extent of inflation of the expandable member is determined via patient feedback while the expandable member is being inflated.

Another aspect is a system for distracting a first vertebra from a second adjacent vertebra. The system includes a catheter and an expandable implant configured to be detachably installed in a collapsed configuration on the distal tip of the catheter. The expandable implant and catheter are configured to be inserted in into a facet joint bounded by the first and second vertebrae to expand the expandable implant within the facet joint to increase a neural foraminal height associated with the first and second vertebrae.

Further aspects of the invention will be brought out in the following portions of the specification, wherein the detailed description is for the purpose of fully disclosing preferred embodiments of the invention without placing limitations thereon.

#### BRIEF DESCRIPTION OF THE DRAWINGS

FIG. 1 is a lateral view of two cervical vertebral members in a stenosed condition.

FIG. 2 is a view of an introducer needle being inserted into the facet joint of the vertebral members in accordance with the present invention.

FIG. 3 illustrates an implant of the present invention being inserted into the facet joint.

FIG. 4. illustrates the implant of FIG. 3 in an expanded configuration.

FIG. 5 illustrates the implant of FIG. 4 with the catheter detached from the implant and removed from the treatment site.

FIG. 6 is another view of the placement of the implant in the facet joint in accordance with the present invention.

FIG. 7 is an expanded view of the implant installed in a collapsed configuration on a catheter.

FIG. 8 illustrates the implant of FIG. 7 in an expanded configuration.

FIG. 9 illustrates an implant of the present invention having a circular cross-section.

FIG. 10 illustrates an implant of the present invention having an oval cross-section.

4

FIG. 11 illustrates an implant of the present invention having a rectangular cross-section.

FIG. 12 illustrates an implant of the present invention having 2-piece design.

FIG. 13 illustrates an implant of the present invention having a taper along its length.

#### DETAILED DESCRIPTION OF THE INVENTION

Referring more specifically to the drawings, for illustrative purposes the present invention is embodied in the apparatus generally shown in FIG. 2 through FIG. 13. It will be appreciated that the apparatus may vary as to configuration and as to details of the parts, and that the method may vary as to the specific steps and sequence, without departing from the basic concepts as disclosed herein.

FIG. 1 illustrates a simplified lateral view of a portion of the cervical spine 10. The basic biomechanical unit or motion segment of the spine consists of two adjacent vertebrae 12 and 14 and the three joint articular complex through which they move and are constrained in relation to one another. The spine articulations generally consist of an intervertebral disc 26 located between the vertebral bodies 26 of adjacent vertebrae 12, 14, and two facet joints 16 symmetrically located laterally from the sagittal plane at the posterior end of the vertebral bodies 26.

The facet joints 16 allow constrained spinal motion, while protecting the contained neural structures. From a kinematic viewpoint, the intervertebral facet joints 16 are highly constrained sliding planar articulations, lubricated by synovial fluid contained within the facet joint capsule 30. In the cervical spine, the geometry of the cervical vertebral bodies provides a high degree of protection for the neural elements by limiting normal motion of the spine to within physiologic limits. The upward inclination of the superior articular surfaces of the facet joints allows for considerable flexion and extension, as well as for lateral mobility.

Minimally invasive surgical access to the facet joint is well documented. Each vertebral segment comprises a spinous process 34 located at the posterior end of the vertebrae, with the vertebral body located anteriorly. Each vertebra comprises an inferior articular (or transverse) process 35 and the superior articular process 37 that form four posterior articulating, e.g. opposing subchondral, surfaces: two superior facets 18 and two inferior facets 16. The inferior facet 18 from the inferior articular process 35 of the upper vertebra 12 and the superior facet from the superior articular process 37 of the lower vertebra 14 form the facet joint 16 on each lateral side of the spine.

Located medial to the articular processes 37 and vertebral bodies 26 is an aperture, or intervertebral foramina 38, that serves as a nerve root canal for the spinal nerves and vessels that transmit signals from the spinal chord to respective locations in the body.

Each facet joint 16 is covered by a dense, elastic articular capsule 28, which is attached just beyond the margins of the articular facets 18, 22. The inside of the capsule is lined by a synovial membrane (not shown) which secretes synovial fluid for lubricating the facet joint. The exterior of the joint capsule is surrounded by a capsular ligament (not shown), which may be temporarily repositioned to give access for insertion of the extendable implant of the present invention, described in further detail below. Thus, from a posterior-lateral approach, access to the facet joint 16 is relatively straightforward and well prescribed, as compared to other regions of the spine which present a higher likelihood of trauma and risk of permanent damage.

## 5

It should also be noted that FIG. 1 depicts cervical foraminal stenosis, e.g. loss of height between the adjacent vertebrae 12, 14. As a result of disc 36 herniation and corresponding height loss, the nerve root canal 38, or intervertebral foraminal height, having a value  $H_S$ , is narrowed relative to that of healthy anatomy. This narrowing of the foraminal height  $H_S$  often leads to compression of the spinal cord and nerve roots (not shown), causing radicular symptoms.

As a result of the stenosed foraminal height  $H_S$ , the height of the facet joint 16, or distance between subchondral articulating surfaces 18 and 22, is also narrowed, (shown as value  $D_S$  in FIG. 1). This may pose complications in the facet joint 16 as well. However, more importantly, because the height of the disc will be relatively fixed, an increase in the facet joint height will also have a corresponding increase in foraminal height, as described in greater detail below.

FIGS. 2-6 show the methods and system 50 of the present invention for performing a minimally invasive procedure configured to distract one or more of the facet joints 16 of vertebrae 12, 14, thereby increasing the dimension of the neural foramen while retaining facet joint mobility. One of the major advantages of minimally invasive surgery is the ability to perform the procedure with minimal tissue trauma. Television image intensifier fluoroscopy may be used to provide guidance for surgeon placement of instrumentation and implants precisely to the desired anatomic target in the facet joint 16. The radiographic landmarks are well taught and the relative procedural difficulty of this technique is low.

Referring to FIG. 2, a standard discography introducer needle 44 (e.g. approximately 21 gauge needle) is inserted into the outer facet capsule 28 to create a perforation or access hole 32 into the facet joint cavity 30. Dye may then be injected through the introducer needle 44 to fluoroscopically confirm that the introducer needle 44 is in the facet joint cavity 30.

Referring now to FIG. 3, a catheter 52 having an expandable implant 60 coupled to the distal end 54 of the catheter 52, may then be guided over into the facet joint cavity 30 through needle 44 such that the distal tip 42 of the implant is located in the proper position in cavity 30.

Once the implant 60 is placed at the correct location of the facet joint 16, the implant is injected with a bio-inert hydrogel to inflate the catheter. Inflation may be achieved with a catheter inflation syringe 56, and the pressure and/or volume may be observed via monitor 58. Further visualization may be achieved by including a contrast dye within the hydrogel. The hydrogel and expandable balloon may be similar to the materials found in the HyperGlide Occlusion Balloon Catheter by Micro Therapeutics, Inc., used for vascular occlusions.

FIG. 4 illustrates the implant 60 in an expanded configuration within the facet joint. As shown in FIG. 4, the hydrogel-inflated expandable implant 60 generates an outward compressive force  $F$  on the subchondral surfaces 18 and 22 to increase the distance between them to a desired treatment or nominal value  $D_T$ . This correspondingly increases the height of the intervertebral foramen to a treatment or nominal value  $H_T$ . The value of  $D_T$ , and resulting increase in  $H_T$  may be predetermined by the surgeon prior to the surgery based on pre-op analysis of the patient's condition and anatomy, and/or may also be iteratively devised by patient feedback of symptom improvement during the procedure.

The size of implant 60 is configured to distract the joint and reverse narrowing of the nerve root canal 38 and alleviate symptoms of cervical stenosis. However, it is also within the scope of the present invention to size the implant according to other spinal conditions, for example to correct for cervical kyphosis or loss of cervical lordosis.

## 6

Once the desired inflation/distraction is achieved, the catheter 52 is detached from the implant 60, and fed out of the patient's body. Referring now to FIG. 5, the expanded implant 60 will occupy the joint cavity 30 such that it will occlude the opening 32 in the facet capsule 28. Because the inflated implant 60 is larger than the opening 32 caused by the violation of the joint by the introducer needle 44, the implant 60 acts as a plug to close off the joint cavity 30. In addition, because the implant is confined within the boundaries of the joint cavity 30, including the facet surfaces 18, 22 and capsule 28, it will remain in its installed position without further anchoring to hold the device in place. Due to the properties of synovial joints and the configuration of the implant 60, it is unlikely that the implant 60 will extrude from the joint once it has been implanted. If further constraint is desired, the external walls of the balloon may be fabricated to have a surface roughness or texture configured to inhibit motion with respect to the walls 18, 22 of the facet joint.

If symmetrical distraction is desired between the adjacent vertebrae, the procedure may be repeated for the second facet joint located between the target vertebrae. However, it is contemplated that only one implant may be necessary to alleviate radicular symptoms.

FIG. 6 illustrates a preferred placement of the implant 60 within the facet joint 16. The average width of the cervical facet is approximately 9 mm. The average depth of the cervical facet is also approximately 9 mm. The preferred location of the capsule is generally the center third of the facet joint cavity 30, as its approximate size will be about 3-4 mm in width, as shown in FIG. 6. The length of the implant 60 will be approximately 8-9 mm, or roughly the depth of the facet joint cavity 30, and therefore may preferably occupy all or nearly all of the joint depth. Preferably, the implant 60 will be configured to expand to up to a height of approximately 3 mm or more. It is appreciated that the above sizing of the implant may vary accordingly to accommodate patient anatomy, condition, or desired foraminal height increase or other preferences defined by the surgeon.

The size, configuration, and placement of implant 60 are configured to provide distraction of the facet joint, while also preserving the mobility between the adjacent vertebrae 12, 14. For example, translation of the articular surfaces 18, 22 with respect to each other (e.g. along the plane of the surfaces) is not restrained, while the undesired translation normal to the articular surfaces 18, 22, (e.g. collapsing), is inhibited. Additionally, the adjacent vertebrae 12, 14 are allowed to rotate about the long axis of the implant 60 with respect to each other, as well as rotate about the spinal column axis. Thus, the implant 60 of the present invention allows for dynamic stabilization and distraction of the facet joint to increase and maintain foraminal height.

FIG. 7 illustrates an expandable balloon implant 60 in a collapsed configuration and attached to distal end 54 of catheter 52. The walls 72 of the balloon may be folded over along the length  $L$  of the balloon to minimize the profile of the balloon 60.

FIG. 8 illustrates expandable balloon implant 60 in its expanded configuration. Balloon implant 60 is generally comprised of one or more exterior walls that are configured to hold and retain the inflatable medium, e.g. hydrogel. In some embodiments, the implant 60 may have a central lumen (not shown), emanating at proximal end 76, and terminating at distal end 74 through the length  $L$  of the balloon. The central lumen allows the implant 60 to be fed over a guide wire, or like device, to the target location in the facet joint 16.

The proximal end 76 will also have a port 70 allowing flow of the inflation medium into the bladder of the balloon. This

port **70** may be self-sealing, wherein the port automatically seals upon detaching catheter **52**, or may incorporate a plug (not shown) or other sealing mechanism that may be fed over guide wire **40** to close and seal up port **70** once the catheter **52** is removed.

The cross section of the implant may comprise a variety of different shapes, as shown in FIGS. 9-12. In FIG. 9, balloon implant **80** comprises an outer wall **82** having a generally circular shape, thus creating a cylindrical structure across the length of the balloon. The thickness  $T$  of the external wall **82** is configured to withstand the compressive loads associated with the facet joint in the cervical spine, and may be varied accordingly. With the cylinder shape implant **80**, the outer wall will generally contact and engage the facet surfaces **18**, **22** in a line down the depth of the facet cavity **30**. The diameter  $D$  of the outer wall **82** will be sized for the desired increase of the foraminal height, e.g. ranging from approximately 1 mm to over 3 mm.

As illustrated in **10**, balloon implant **90** may comprise an elliptical or oval cross section, having a height  $H$  sized for desired increase of the foraminal height, and width  $W$ . A rectangular cross section may also be used, as shown with implant **100** of FIG. **11**.

The implants **80**, **90** and **100** may be fabricated by a number of methods currently available in the art. For example, the implant may be formed as a single piece structure over a mandrel (not shown) having varying cross section for the central lumen (if needed) and outer walls **82**, **92**, **102**.

In an alternative embodiment shown in FIG. **12**, the balloon **110** may comprise a bladder having upper wall **114** and lower wall **115** that are heat sealed at the sides **112**.

As illustrated in FIG. **13**, the balloon may also be tapered along its length to accommodate the anatomy of the facet joint **16**, as seen with balloon **120**, wherein the leading or distal end **124** has a smaller profile than the trailing or distal end **126**.

The extendable implants above may comprise an elastic material, e.g. biocompatible polymer, which allows the implant to expand to a varying range in sizes. Alternatively, the implant may comprise an inelastic material that has a maximum inflation capacity, and wherein a number of predetermined sizes may be available to the surgeon according to the desired size determined by the surgeon.

The implant **60** will generally be sized to accommodate the geometry of the patient anatomy and target foraminal height. For cervical herniations, the implant **60** will typically be installed from the C4/C5 joint down to C7/T1 (95% of all cervical herniations occur at C5/6 & C6/7). The height of the implant **60** may range from approximately 1 mm to over 3 mm, depending on the patient anatomy. For the cylindrical-shaped balloon **80** of FIG. **9**, the width will roughly equal the height. However, as shown in FIGS. **10-12**, the width may be increased for the desired stabilizing effect.

Although the embodiments disclosed above are directed primarily to installation in the cervical facet joint, it is contemplated that the devices and methods may also be used to increase foraminal dimension in other regions of the spine, e.g. thoracic, lumbar, etc.

Although the description above contains many details, these should not be construed as limiting the scope of the invention but as merely providing illustrations of some of the presently preferred embodiments of this invention. Therefore, it will be appreciated that the scope of the present invention fully encompasses other embodiments which may become obvious to those skilled in the art, and that the scope of the present invention is accordingly to be limited by nothing other than the appended claims, in which reference to an element in the singular is not intended to mean "one and only

one" unless explicitly so stated, but rather "one or more." All structural, chemical, and functional equivalents to the elements of the above-described preferred embodiment that are known to those of ordinary skill in the art are expressly incorporated herein by reference and are intended to be encompassed by the present claims. Moreover, it is not necessary for a device or method to address each and every problem sought to be solved by the present invention, for it to be encompassed by the present claims. Furthermore, no element, component, or method step in the present disclosure is intended to be dedicated to the public regardless of whether the element, component, or method step is explicitly recited in the claims. No claim element herein is to be construed under the provisions of 35 U.S.C. 112, sixth paragraph, unless the element is expressly recited using the phrase "means for."

What is claimed is:

**1.** A method for treating cervical foraminal stenosis, the method comprising:

- a) identify a nerve root canal between an upper vertebra and a lower vertebra, the nerve root canal including a stenosed intervertebral foraminal height;
- b) identifying a facet joint adjacent the nerve root canal, the facet joint including an inferior articulating surface of the upper vertebra and a superior articulating surface of the lower vertebra, a distance between the superior articulating surface and the inferior articulating surface being narrowed at least in part because of the stenosed intervertebral foraminal height;
- c) providing an implant comprising an upper wall, a lower wall, a proximal end and a distal end, wherein the upper wall and lower wall are formed of an inelastic material and the implant is configured to transition to an expanded configuration from a non-expanded configuration;
- d) minimally invasively accessing the facet joint with a guide tool;
- e) minimally invasively routing the implant into the facet joint by routing along the guide tool the implant in the non-expanded configuration and supported on a distal end of the delivery tool; and
- f) acting at the proximal end of the implant with the delivery tool to cause the implant to transition from the non-expanded configuration to the expanded configuration, the transition of the implant causing the upper wall to act against the inferior articulating surface and the lower wall to act against the superior articulating surface, thereby increasing the distance between the superior articulating surface the inferior articulating surface and increasing the stenosed intervertebral foraminal height.

**2.** The method of claim **1**, further comprising selecting the implant from a number of predetermined sizes.

**3.** The method of claim **1**, wherein the guide tool includes a guidewire.

**4.** The method of claim **1**, wherein the delivery tool includes a catheter.

**5.** The method of claim **1**, wherein step d) further includes puncturing an access hole in a facet capsule of the facet joint.

**6.** The method of claim **5**, wherein an introducer needle punctures the access hole in the facet capsule.

**7.** The method of claim **1**, wherein the implant includes a transverse cross section when in the expanded configuration that is generally round, elliptical or square.

**8.** The method of claim **1**, wherein the upper wall and lower wall are generally parallel to each other when viewed via a longitudinal cross section when the implant is in the expanded configuration.

## 9

9. The method of claim 1, wherein the upper wall and lower wall form a generally wedge shaped relationship to each other when viewed via a longitudinal cross section when the implant is in the expanded configuration.

10. The method of claim 9, wherein the distal end forms a narrow end of the wedge shaped relationship, and the proximal end forms a wide end of the wedge shaped relationship.

11. The method of claim 1, wherein acting at the distal proximal end of the implant with the delivery tool to cause the implant to transition further includes employing the delivery tool to deliver something between the upper wall and the lower wall.

12. The method of claim 11, wherein the something includes a fluid, the implant including a reservoir between the upper wall and the lower wall.

13. The method of claim 12, wherein the fluid includes a hydrogel.

14. The method of claim 12, wherein the implant has a maximum inflation capacity.

## 10

15. The method of claim 14, further comprising selecting the implant from a number of predetermined sizes.

16. The method of claim 11, wherein the proximal end of the implant includes a port through which the fluid is delivered.

17. The method of claim 1, wherein an exterior surface of at least one of the upper wall or lower wall is configured to inhibit motion of the at least one of the upper wall or lower wall to relative to the respective inferior articulating surface or the superior articulating surface.

18. The method of claim 17, wherein the exterior surface, in being configured to inhibit motion, includes at least one of a surface roughness or texture.

19. The method of claim 1, further comprising performing step f) with a patient under conscious sedation and obtaining intra-operative symptom feedback from the patient.

20. The method of claim 1, wherein the implant is sized to accommodate a geometry of anatomy of a patient.

\* \* \* \* \*

UNITED STATES PATENT AND TRADEMARK OFFICE  
**CERTIFICATE OF CORRECTION**

PATENT NO. : 8,348,979 B2  
APPLICATION NO. : 12/889122  
DATED : January 8, 2013  
INVENTOR(S) : Bruce McCormack

Page 1 of 1

It is certified that error appears in the above-identified patent and that said Letters Patent is hereby corrected as shown below:

Claim 11, column 9, line 8, delete the word “distal”.

Signed and Sealed this  
Ninth Day of April, 2013



Teresa Stanek Rea  
*Acting Director of the United States Patent and Trademark Office*