

US008290578B2

(12) **United States Patent**  
**Schneider**

(10) **Patent No.:** **US 8,290,578 B2**  
(45) **Date of Patent:** **Oct. 16, 2012**

(54) **METHOD AND APPARATUS FOR COMPLEX IMPEDANCE COMPENSATION**

5,697,377 A 12/1997 Wittkampf  
5,718,241 A 2/1998 Ben-Haim et al.  
5,836,990 A 11/1998 Li  
5,837,001 A 11/1998 Mackey

(75) Inventor: **Clinton W. Schneider**, Plymouth, MN (US)

(Continued)

(73) Assignee: **St. Jude Medical, Atrial Fibrillation Division, Inc.**, St. Paul, MN (US)

FOREIGN PATENT DOCUMENTS

WO 2007/067941 6/2007

(\*) Notice: Subject to any disclaimer, the term of this patent is extended or adjusted under 35 U.S.C. 154(b) by 133 days.

OTHER PUBLICATIONS

Cho, Design of Electrode Array for Impedance Measurement of Lesions in Arteries, *Physiol. Meas.* 26 (2005) S19-S26, doi: 10.1088/0967-3334/26/2/002.

(21) Appl. No.: **11/966,320**

(Continued)

(22) Filed: **Dec. 28, 2007**

*Primary Examiner* — Max Hindenburg  
*Assistant Examiner* — Adam Eiseman

(65) **Prior Publication Data**

US 2009/0171235 A1 Jul. 2, 2009

(74) *Attorney, Agent, or Firm* — Dykema Gossett PLLC

(51) **Int. Cl.**  
**A61B 5/05** (2006.01)  
**A61B 18/04** (2006.01)  
**A61B 18/18** (2006.01)

(57) **ABSTRACT**

A compensation circuit has a predetermined, known complex impedance and is located in a handle of a catheter or in a distal end of a cable that connects to the catheter. The compensation circuit is probed with a pilot signal produced by a compensation control that is external to the catheter, by way of an electrical connection through the connecting cable. The compensation control measures the complex impedance, which is the combination of the circuit's known impedance as well as that of the cable. The compensation control then determines the difference between the measured and the known complex impedances. The difference represents that which is attributable to the cable, and is used to compensate or cancel out such cable-related contributions to complex impedance in measurements made over other electrical connections in the same cable. In another aspect, an unknown tissue is identified as one of a plurality of possible tissue types such as regular myocardium, scar and fat based on the measured phase angle of the complex impedance of the unknown tissue.

(52) **U.S. Cl.** ..... **600/547**; 606/34; 606/41; 606/42; 606/45; 606/48

(58) **Field of Classification Search** ..... 600/547; 606/34, 45, 49

See application file for complete search history.

(56) **References Cited**

U.S. PATENT DOCUMENTS

4,641,649 A 2/1987 Walinsky et al.  
5,297,549 A 3/1994 Beatty et al.  
5,311,866 A 5/1994 Kagan et al.  
5,341,807 A 8/1994 Nardella  
5,423,808 A \* 6/1995 Edwards et al. .... 606/34  
5,447,529 A 9/1995 Marchlinski  
5,562,721 A 10/1996 Marchlinski  
5,673,704 A 10/1997 Marchlinski

**12 Claims, 5 Drawing Sheets**

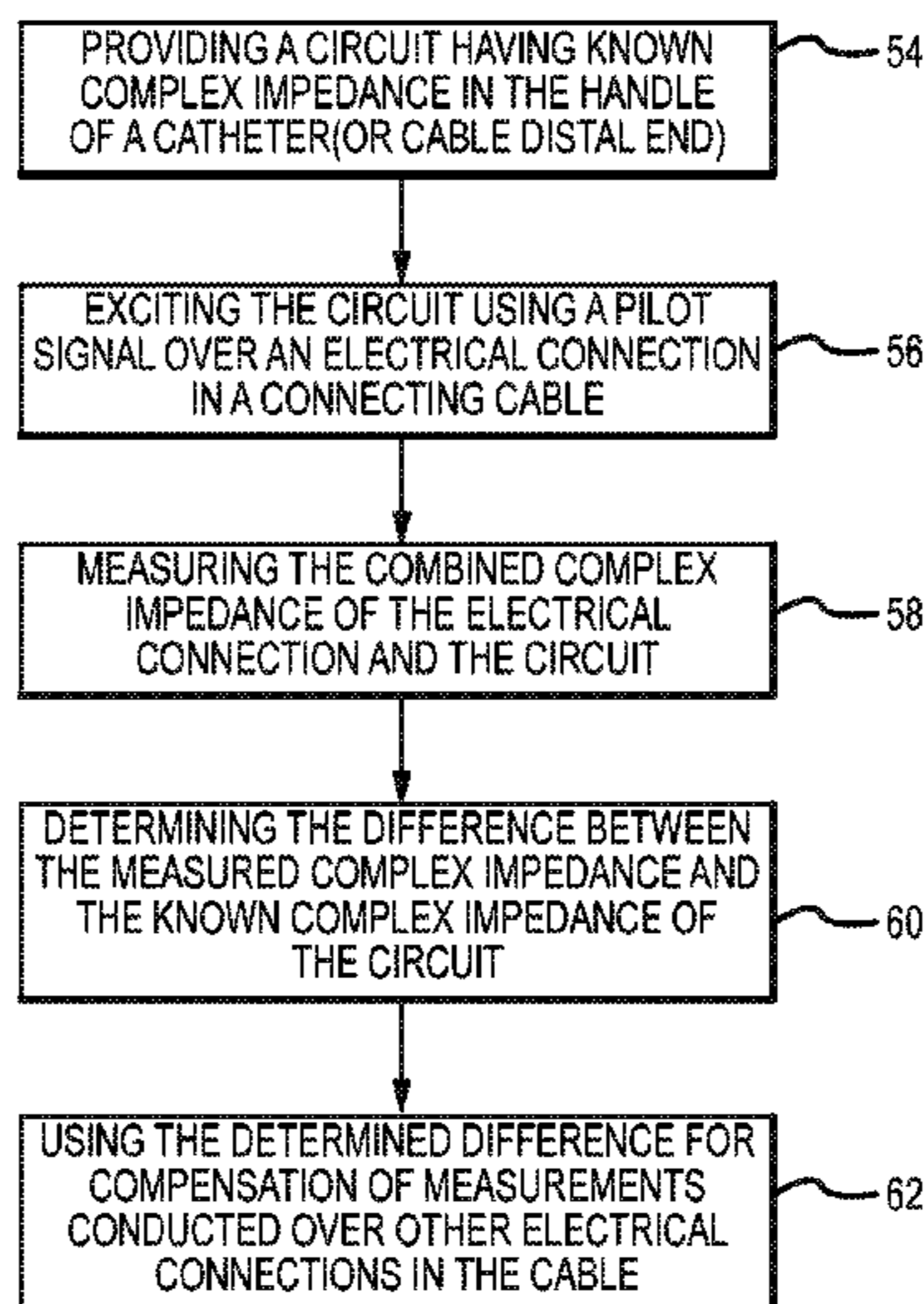

U.S. PATENT DOCUMENTS

5,954,665 A 9/1999 Ben-Haim  
6,063,078 A 5/2000 Wittkampf  
6,179,824 B1 1/2001 Eggers et al.  
6,226,542 B1 5/2001 Reisfeld  
6,256,540 B1 7/2001 Panescu  
6,423,057 B1\* 7/2002 He et al. .... 606/34  
6,443,894 B1 9/2002 Sumanaweera et al.  
6,471,693 B1 10/2002 Carroll  
6,511,478 B1 1/2003 Burnside et al.  
6,690,963 B2 2/2004 Ben-Haim et al.  
6,965,795 B2 11/2005 Rock  
7,263,397 B2 8/2007 Hauck  
2002/0049375 A1 4/2002 Strommer et al.  
2002/0077627 A1 6/2002 Johnson et al.  
2003/0045871 A1 3/2003 Jain  
2003/0093067 A1 5/2003 Panescu  
2003/0187430 A1\* 10/2003 Vorisek ..... 606/34  
2004/0030258 A1 2/2004 Williams et al.  
2007/0073179 A1 3/2007 Afonso  
2007/0100332 A1 5/2007 Paul  
2007/0123764 A1 5/2007 Thao et al.

2007/0244479 A1 10/2007 Beatty  
2007/0255162 A1 11/2007 Abboud et al.  
2008/0234564 A1 9/2008 Beatty et al.

OTHER PUBLICATIONS

Fenici et al., Biomagnetically Localizable Multipurpose Catheter and Method for MCG Guided Intracardiac Electrophysiology, Biopsy and Ablation of Cardiac Arrhythmias, Int'l Journal of Cardiac Imaging 7: 207-215, 1991.  
Gales, Use of Bioelectrical Impedance Analysis to Assess Body Composition of Seals, Marine Mammal Science 10 (1), 1-12 (Jan. 1994), doi: 10.1111/j.1748-7692.1994.tb00385.x.  
Masse et al., A Three-Dimensional Display for Cardiac Activation Mapping, PACE, p. 538, vol. 14; Apr. 1991.  
Salazar, Transmural Versus Nontransmural In Situ Electrical Impedance Spectrum for Healthy, Ischemic, and Healed Myocardium, IEEE Transactions on Biomedical Engineering, vol. 51, No. 8, Aug. 2004.  
International Search Report and Written Opinion for PCT/US2008/084194 mailed Feb. 5, 2009.  
International Search Report and Written Opinion for PCT/US2008/084200 mailed Jan. 22, 2009.

\* cited by examiner

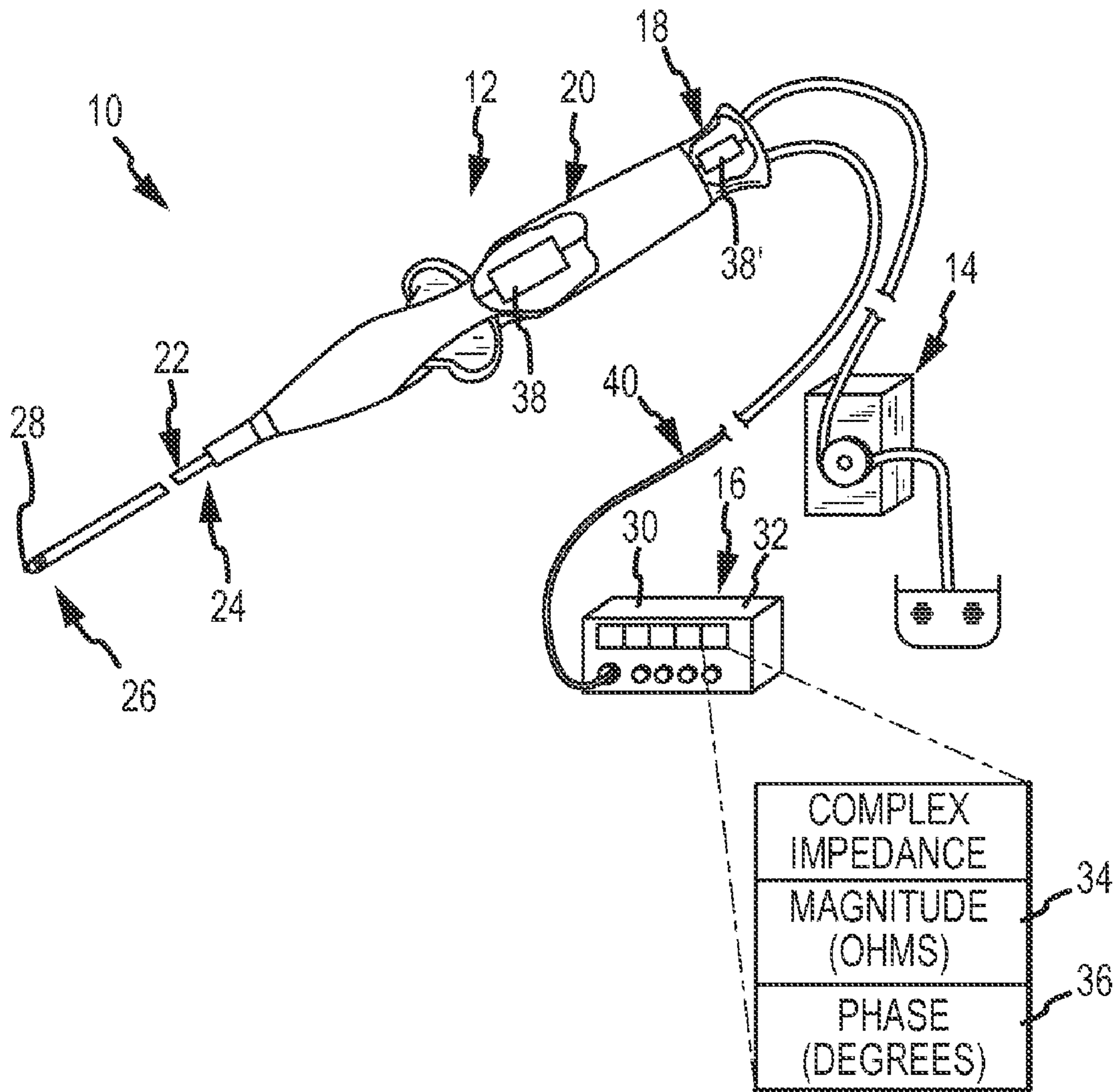

FIG. 1



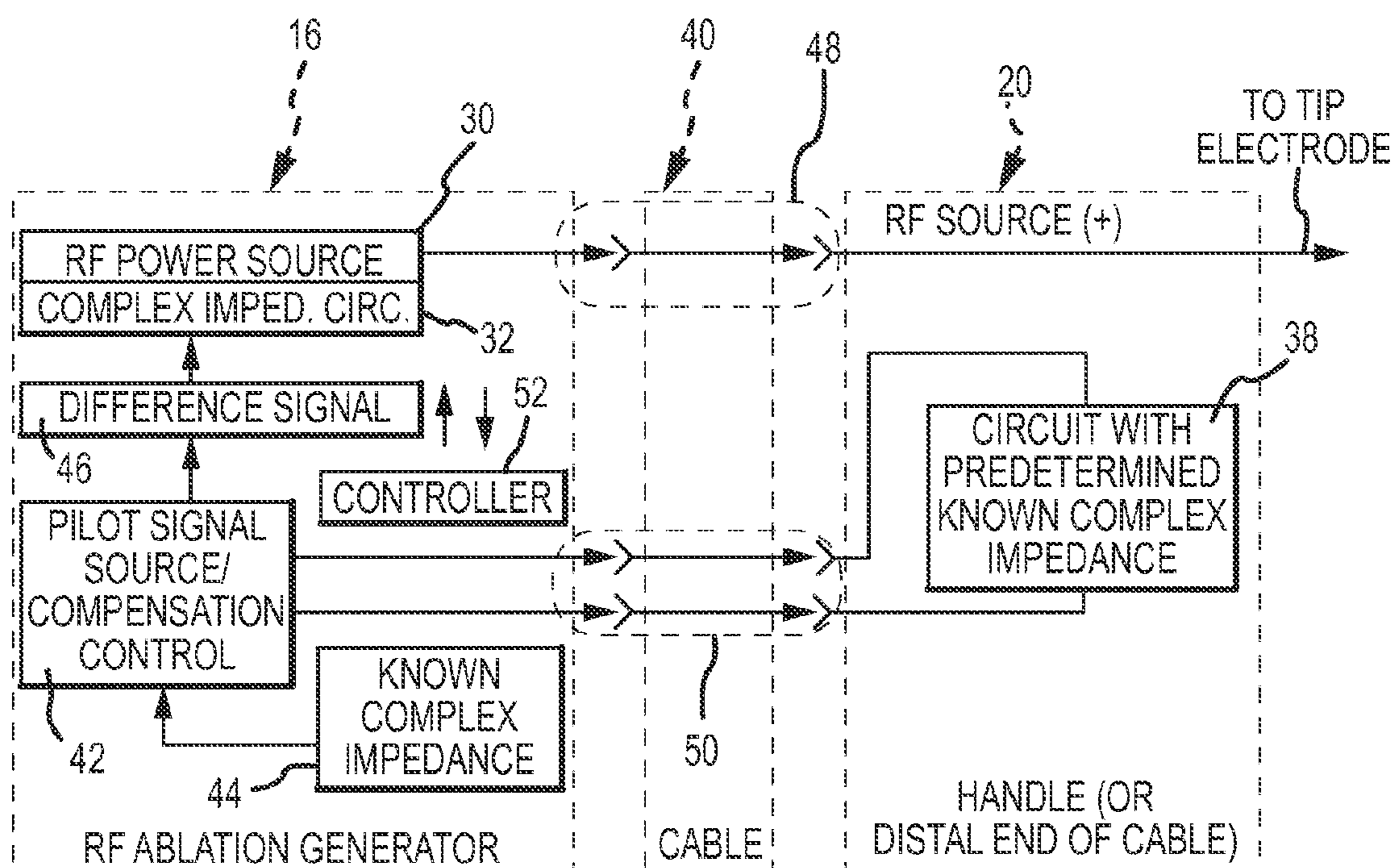

FIG.2

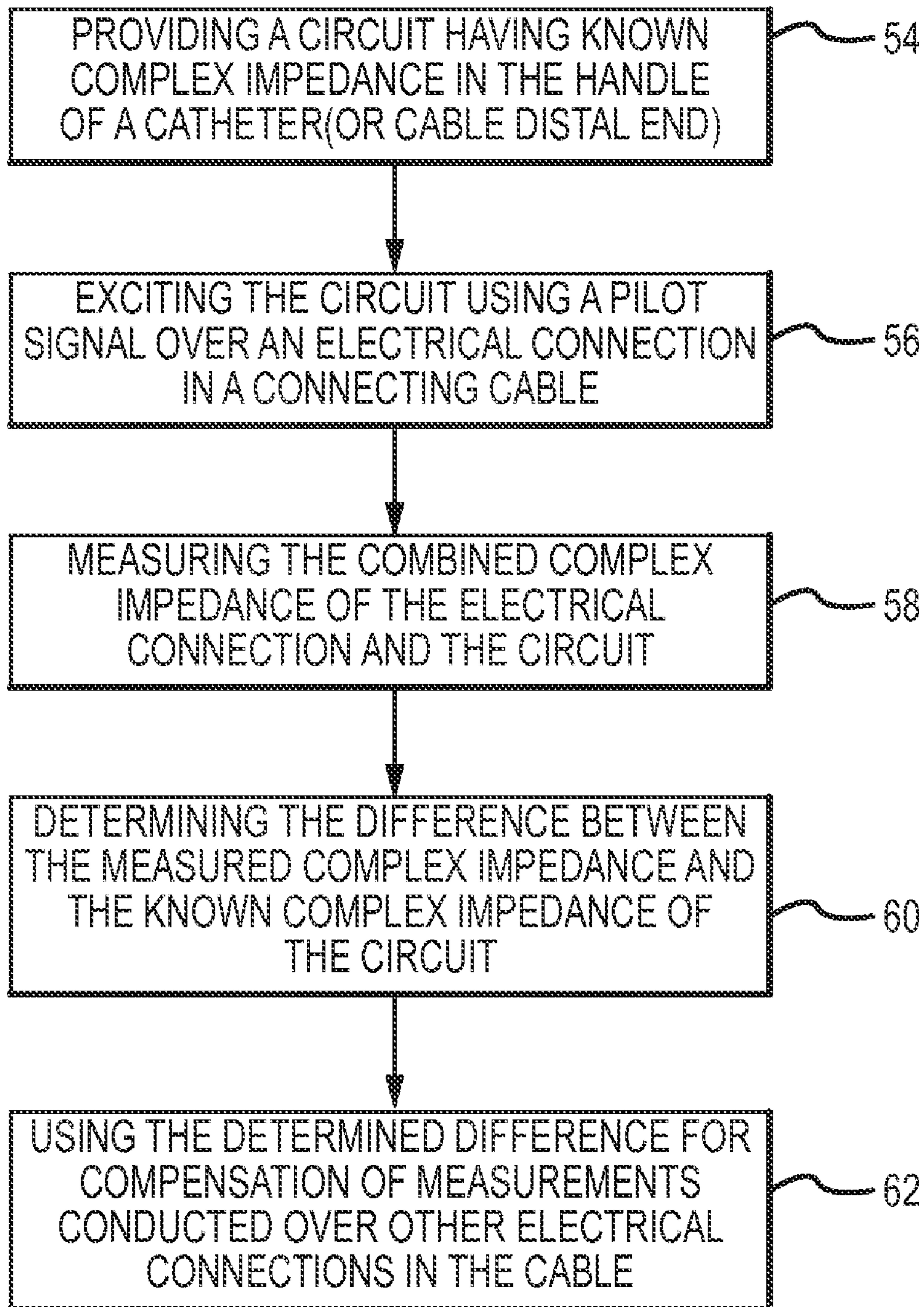

FIG. 3

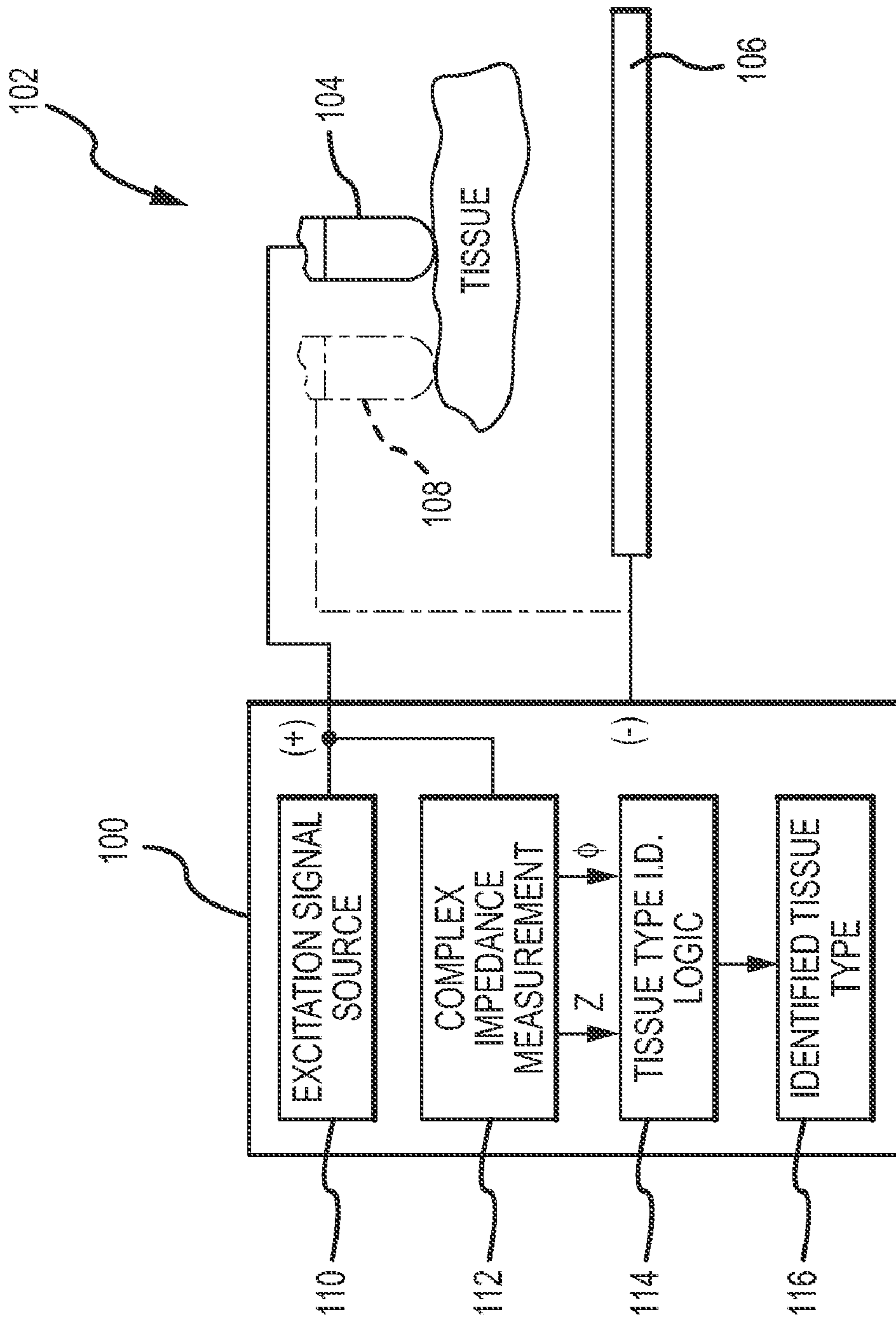

FIG.4

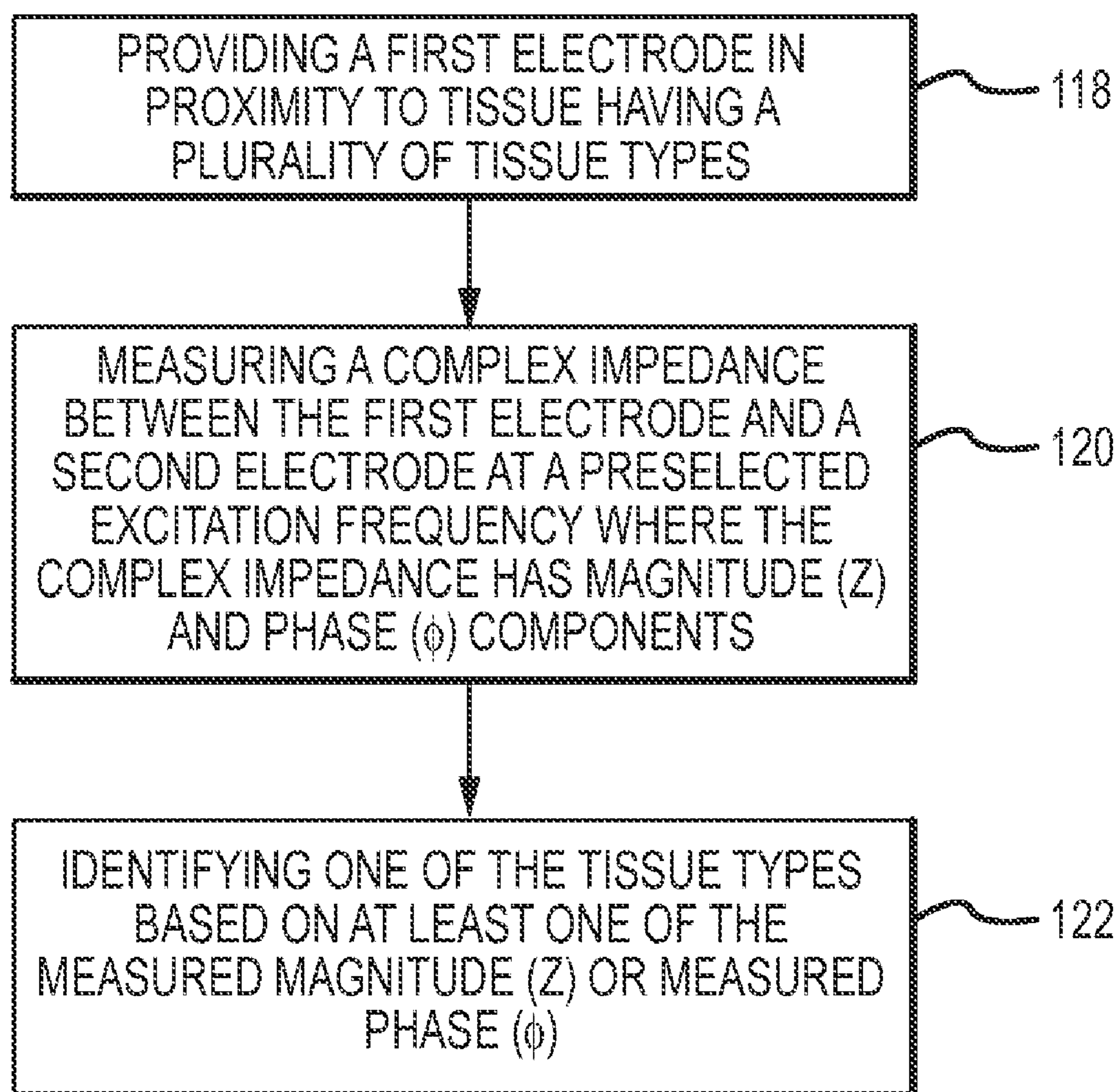

FIG. 5



## METHOD AND APPARATUS FOR COMPLEX IMPEDANCE COMPENSATION

### BACKGROUND OF THE INVENTION

#### a. Field of the Invention

The instant invention relates to a method and apparatus for complex impedance compensation, and, in another aspect, a method and apparatus for using complex impedance measurements including a phase angle to detect tissue morphology.

#### b. Background Art

Many applications have been proposed for the use of a measured impedance of tissue, for example cardiac tissue, and not surprisingly a number of approaches for making such impedance measurements have also been proposed. One procedure where an impedance is measured and used is in cardiac catheter ablation.

As general background, there are a number of methods used for ablation of desired areas, including, for example, radio frequency (RF) ablation. RF ablation is accomplished by transmission of radio frequency energy to a desired target area through an electrode assembly to ablate tissue at the target site. RF ablation may generate significant heat if not controlled. It is therefore known to provide an RF ablation generator with certain feedback features, such as temperature and impedance. To provide such feedback for the physician/clinician's use during the procedure, conventional RF ablation generators are typically configured to measure and display a magnitude of a complex impedance  $|Z|$  intended to represent the impedance of the patient's tissue near and around the ablation electrode. To make the impedance measurement, conventional generators use one tip conductor (i.e., one lead through the catheter to the ablation tip electrode) and one ground conductor (i.e., one lead from a ground patch or the like back to the generator). The frequency of the source used to make the impedance measurement is generally the ablation energy source frequency, which can typically vary from 50 kHz to 500 kHz depending on the ablation generator. Such impedance measurements are commonly used to assess tissue heating and tissue-electrode contact levels. However, one shortcoming in the art is that such measurements are subject to variation due to factors unrelated to the condition of the tissue (i.e., non-physiologic changes). For example, coiling of an ablation generator cable during the procedure can increase its inductance and thus alter the impedance measurement, resulting in an inaccurate reading that is not completely indicative of the actual tissue condition. This scenario is particularly problematic where a phase angle of the complex impedance of cardiac tissue is sought, since this parameter is fairly low to begin with ( $<15^\circ$ ) for the frequencies typically used for RF ablation.

Another shortcoming is that conventional approaches for complex impedance measurements do not provide any intelligence as to tissue morphology, but rather appear to relate to tissue heating and electrode-to-tissue contact levels. An improvement to conventional approaches has been proposed which uses a phase measurement to assess the contact level for the catheter electrode. Tissue is more capacitive and resistive than myocardium due to the cell structure. Therefore, compared with blood, the measured impedance becomes more capacitive and the phase angle becomes more negative when the electrode is in contact with myocardium.

There is therefore a need to minimize or eliminate one or more of the problems set forth above.

### BRIEF SUMMARY OF THE INVENTION

It is desirable to be able to provide a method and apparatus for measuring a complex impedance of tissue that can incor-

porate compensation for changes in the equipment, namely the connecting cable, such as by cable coiling or the like. It is also desirable to provide a method and apparatus to detect tissue morphology using a complex impedance measurement, for example based on a phase angle of the tissue's complex impedance. Detecting a tissue type can be useful in various applications, including diagnosis/therapy of ventricular tachycardia (VT). For example, one of the approaches for VT ablation is to ablate on the border between the scar and normal tissue to isolate VT.

In a first aspect of the present invention, a compensation apparatus is provided directed to overcoming one or more of the problems noted above. In concept, the compensation apparatus is configured to determine a complex impedance attributable to a connecting cable. It then uses this determination to provide compensation for another complex impedance measurement within the same cable. The compensation apparatus is preferably provided for use with a catheter having an electrode and a cable. The cable is configured to allow a first electrical connection to be made between the catheter and an electrical device (e.g., an ablation generator) so as to allow the device to electrically interact with the electrode (e.g., for an ablation procedure). The first electrical connection (the "working connection") is the one that will have the compensation (i.e., the effects of the cable removed).

The compensation apparatus includes a circuit and a compensation control. The circuit has a predetermined complex impedance when probed or excited by a pilot signal having a predetermined frequency. The known-impedance circuit is located in either the handle of the catheter or a distal end of the cable. The compensation control is configured to generate the pilot signal. The cable is arranged to allow a second electrical connection (the "control" connection) to be made between the compensation control and the circuit. The second electrical connection in the cable is the one that will be used to measure the level of undesired (non-physiologic) variations. The compensation control is configured to measure the complex impedance of the combination of the cable (i.e., over the second electrical connection) and the circuit, which has the known impedance. The compensation control is further configured to then determine a difference between the measured and known complex impedances. The difference, if any, thus represents variation due to the cable configuration, may be used for compensating on any complex impedance measurements over the first electrical connection within the same cable.

In a second aspect of the invention, a method for determining a tissue type is provided. In a preferred embodiment, the tissue under test may be one of a plurality of different tissue types, including regular myocardium, scar/ischemia and fat. The method includes the steps of providing a first electrode in contact with the tissue. Next, measuring a complex impedance, at a predetermined frequency, between the first electrode and second electrode such as a reference electrode (patch). The predetermined frequency may be between about 20 kHz and 100 kHz, which reveals the capacitive properties of the tissue, while minimizing contributions by other factors not of interest (e.g., the reactance of any blood, the reactance due to the electrode-electrolyte interface, etc.). The complex impedance includes a magnitude and a phase angle component. Finally, the method includes the step of identifying one of the tissue types based on at least one of the measured magnitude and phase angle components, preferably at least the phase angle component.

The foregoing and other aspects, features, details, utilities, and advantages of the present invention will be apparent from



reading the following description and claims, and from reviewing the accompanying drawings.

### BRIEF DESCRIPTION OF THE DRAWINGS

FIG. 1 is a diagrammatic view of an RF ablation embodiment having complex impedance compensation in accordance with the present invention.

FIG. 2 is a simplified block diagram showing, in greater detail, the complex impedance compensation apparatus of FIG. 1.

FIG. 3 is a flow chart diagram showing a method for complex impedance compensation in accordance with the present invention.

FIG. 4 is a simplified diagrammatic and block diagram of an apparatus for determining a tissue type in accordance with the present invention.

FIG. 5 is a flow chart diagram showing a method for determining a tissue type in accordance with the present invention.

### DETAILED DESCRIPTION OF THE INVENTION

The invention that will be described herein includes two main aspects. In the first aspect, an apparatus and method for complex impedance compensation is provided. The first aspect of the invention overcomes a problem described in the Background, namely, changes in the measured complex impedance that are observed but which are due to changes in the configuration of the equipment, namely the connecting, such as by cable coiling and the like. The first aspect provides the ability to measure the complex impedance with respect to the tissue more accurately, which, as understood by those in the art, will have many useful applications. In the second aspect of the invention, an apparatus and method is provided for determining a tissue type based on, preferably, a phase angle component and/or also a magnitude component of the tissue's complex impedance. The second aspect of the invention is useful in identifying tissue during certain applications, for example, identifying scar tissue in ventricular tachycardia (VT) applications or epicardial applications for locating fat and scar tissue. For VT ablation, one of the current approaches is to ablate on the border between the scar and normal tissue to isolate the scar that triggers VT. As to epicardial RF application, one of the important issues is to apply energy to regular tissue and avoid RF application on fat which does not create an efficacious lesion.

It should be understood that the two aspects of the invention are not limited to the particular illustrated embodiments. For example, the apparatus and method for each may be used with catheters/catheter systems for diagnostic, therapeutic, mapping and/or ablative procedures, to name just a few.

As further background, a complex impedance ( $Z$ ) can be expressed as set forth in equation (1)

$$Z=R+jX \quad (1)$$

Where  $R$  is a resistance component; and  $X$  is a reactance component that is based on both capacitance and inductance contributions. A complex impedance can also be expressed as set forth in equation (2):

$$Z=|Z|\angle\phi \quad (2)$$

Where  $|Z|$  is the magnitude of the complex impedance and  $\phi$  is called the phase angle or alternatively sometimes simply

the "phase." These quantities are defined in equations (3) and (4):

$$|Z|=\sqrt{R^2+X^2} \quad (3)$$

$$\tan \phi=X/R \quad (4)$$

As used herein, the term complex impedance is taken to include a magnitude and a phase angle. Where a magnitude of the complex impedance is intended, an absolute value of  $Z$  will be denoted,  $|Z|$ . With this background, the first and second aspects of the invention will now be set forth.

#### Impedance Compensation for Catheters and Cables

Referring now to the drawings wherein like reference numerals are used to identify identical components in the various views, FIG. 1 is a simplified, perspective view of an exemplary system **10** for conducting a diagnostic or therapeutic function, in which the first aspect (impedance compensation) may be practiced. In particular, the first aspect provides the capability to compensate for complex impedance variations due to the cable. The first aspect, generally, involves deploying a circuit, one with a known complex impedance, and then measuring the complex impedance of that circuit over a first electrical connection through a cable. Any measured variations from the known, complex impedance can then be attributed to the cable. Recall, the connecting cable may be a source of variation in measured complex impedance due to non-physiologic changes (e.g., cable coiling, cable being wrapped around a steel bedpost to form an inductor, etc.). The variation attributed to the cable can then be cancelled out of other measurements in the same cable, for example, when making a complex impedance measurement of tissue over another electrical connection in that same cable. In the exemplary RF ablation embodiment, a first electrical connection, to which the compensation will be applied, is an RF ablation source connection from an RF ablation generator through a generator cable to the ablation catheter. It is typical to make an impedance measurement through this connection. A second electrical connection through the same cable is set up for the purposes of determining what, if any, changes in complex impedance may be due to the cable. It should be understood, however, that this configuration is exemplary in nature only, and that many other arrangements may be practiced, consistent with the teachings of the present invention.

With continued reference to FIG. 1, in the exemplary RF ablation embodiment, a system **10** is shown to include a catheter **12** operably connected to a fluid source **14**, such as a pump assembly, and an energy source, such as an RF ablation generator **16**. The fluid source **14** and the RF ablation generator **16** may serve to facilitate the operation of ablation procedures and may involve monitoring any number of chosen variables (e.g., temperature of ablation electrode, ablation energy, and position of the assembly), assisting in manipulation of the assembly during the use, and providing the requisite energy source. Furthermore, additional components may be integrated into the system **10**, such as visualization, mapping and navigation components known in the art, including among other things, NavX® or other systems. Moreover, it should be understood that embodiments consistent with the present invention may, and typically will, include other features not shown or described herein for the sake of brevity and clarity. For example, an ablation catheter may typically include additional electrodes (and corresponding leads), a temperature sensor (and corresponding leads), and other features as known in the art.

The catheter **12** may include a cable connector or interface **18**, a handle **20** and a shaft **22** having a proximal end **24** and a distal end **26** near which an ablation electrode **28** is disposed. It should be re-iterated that while one electrode **28** is shown, the catheter **12** may include a plurality of electrodes, and that in any event, the electrode **28**, in other embodiments (other than RF ablation) may be used for any number of



diagnostic and/or therapeutic purposes. For instance, such electrodes and therefore such catheters may be used for performing ablation procedures, cardiac mapping, electrophysiological (EP) studies, and other like procedures. Accordingly, the present invention is not limited to any one type of catheter or catheter-based system or procedure.

The general structural and functional features of catheter systems such as those generally comprising the catheter **12**, the fluid source **14** and the RF ablation generator **16** are generally well known to those of skill in the art. For example, the fluid source **14** can comprise various known assembly, including fixed volume rolling pumps, variable volume syringe pumps and other pump assembly known to those skill in the art. Moreover, the fluid provided by fluid source **14** may comprise a suitable biocompatible fluid, such as saline. Subject to the modifications described below, the RF ablation generator **16** may comprise conventional apparatus, such as a commercially available unit sold under the model number IBI-1500T RF Cardiac Ablation Generator, available from Irvine Biomedical, Inc. Of course, the RF ablation generator **16** can also comprise various other known energy sources.

With continued reference to FIG. **1**, the RF ablation generator **16** includes an RF power source **30** configured to generate an ablation signal. The RF ablation signal may typically have a frequency within the range of 50 kHz and 500 kHz. The ablation generator **16** further includes an impedance determining circuit **32** configured to determine a complex impedance of a tissue volume proximate the tip electrode **28**. As shown, the complex impedance may comprise a magnitude component **34** (e.g., expressed in ohms) and a phase angle component **36** (e.g., expressed in degrees). The power source **30**, as described above, may comprise conventional components. The impedance determining circuit **32** may also comprise conventional components known in the art, subject to the modifications described herein.

FIG. **1** further shows a circuit **38**, which in one embodiment is located in the handle of the ablation catheter **12**, and in another embodiment (circuit **38'**) is alternatively located in the distal end of a generator cable **40**. As used herein, unless otherwise stated, both circuits **38** and **38'** are the same (only the location is different). Therefore, where further reference is made to circuit **38** it should be understood that such reference also applies to circuit **38'**. In either case, the circuit **38** (or **38'**) has a predetermined, known complex impedance when probed or excited by a pilot signal having a predetermined frequency. The predetermined frequency may preferably be between 100 Hz and 1 MHz, more preferably between 6 kHz and 50 kHz, and still more preferably be about 20 kHz. In various embodiments, the circuit **38** may be one selected from the group including: a loop-back circuit (i.e., a short circuit), a series-connected resistor circuit, series-connected resistor-inductor (RL) circuit, a series-connected resistor-capacitor (RC) circuit, a series-connected resistor-inductor-capacitor (RLC) circuit, a parallel-connected RL circuit, a parallel-connected RC circuit, a parallel-connected RLC circuit or a combination of any of the foregoing. It should be appreciated that when the R, L and C values are all set to zero, the circuit **38** simplifies to the loop-back circuit described above, which still satisfies the property of having a known, complex impedance (i.e., one would expect relatively low resistance with negligible phase shift for a loop-back).

FIG. **2** is a simplified block diagram showing, in greater detail, an arrangement for complex impedance compensation. In one embodiment, a compensation control **42** is provided, which may be integrated within the ablation generator **16**; however, in an alternate embodiment, the compensation control **42** may be provided as a separate unit. FIG. **2** further

shows a known complex impedance block **44** (i.e., a block that provides the magnitude/phase values known for the circuit **38**), a difference signal **46**, a first electrical connection **48** over the cable **40** and a second electrical connection **50** that is independent from the first electrical connection **48** but is also over the same cable **40**.

As shown, the cable **40** is configured generally to allow the first electrical connection **48** to be made between the RF ablation source **30** and the catheter **12** (i.e., and in turn to the ablation tip electrode **28**). The first electrical connection **48** is the connection for which compensation will be made. Additionally, the cable **40** is configured to allow the second electrical connection **50** to be made between the compensation control **42** and the known-impedance circuit **38**. The second electrical connection **50** is the connection upon which the difference signal **46** (i.e., a compensation or cancellation factor) will be determined. While the second connection **50** is illustrated in exemplary fashion as having two wires, it should be understood that the invention is not so limited. More than two wires may be used to form the second electrical connection **50**, and likewise, a single wire may be employed.

The compensation control **42** is configured to generate the above-described pilot signal at the predetermined frequency for probing or exciting the circuit **38**. Specifically, the compensation control **42** is configured to measure the complex impedance of the combination of the second electrical connection **50** and the circuit **38**. Since the complex impedance of the circuit **38** is known and available in advance, the compensation control **42** is further configured to determine a difference between the measured complex impedance and the predetermined (known) complex impedance of the circuit **38**. Any difference, be it expressed in terms of a magnitude (e.g., ohms), a phase angle (e.g., degrees) or both, would then be deemed attributable to the configuration of the cable **40**. The compensation control **42** is thus further configured to generate the difference signal **46** indicative of the difference as determined by the control **42**. For example, if the measured complex impedance, when taken relative to the predetermined, known complex impedance, indicates an additional phase lag of X degrees due to cable coiling or the like adding inductance, the difference signal **46** may be generated to indicate the additional X degrees lag. The difference signal **46** is provided to the complex impedance determining circuit **32**, which is configured to use the difference signal **46** in making compensatory adjustments. Specifically, the circuit **32** is configured to use the difference signal **46** to cancel or null out cable configuration-related variations in any measured complex impedance taken over the first electrical connection **48**. The particulars of the difference signal may take many forms, although it should be understood that the selected form will be coordinated with the form expected by the complex impedance determining circuit **32**.

The compensation control **42**, in one embodiment, may be a computer-implemented apparatus operating under software control. For this purpose, a controller **52** (which may already be present in the ablation generator **16** if integrated) may be configured to execute pre-programmed instructions to perform the various functions described herein. The compensation control **42** may include various controlled hardware, such as a pilot source generator to generate the pilot signal, as well as structure suitable for measuring the resultant signal induced by the application of the pilot signal over the second electrical connection **50** to the circuit **38**. These structures may comprise conventional apparatus well known to those of ordinary skill in the art. In the computer-implemented embodiment, the difference signal **46** may take the form of a compensation factor or parameter, which may be stored in a



memory and available for access by the impedance determining circuit 32. Additionally, the compensation control 42 may be further configured to update the difference signal 46 on a periodic basis, so as to provide real-time complex impedance compensation.

In an alternate embodiment, the compensation control 42 may be implemented completely in hardware employing various means to measure a difference in magnitude and phase (e.g., phase detector) between the measured complex impedance (i.e., the cable plus the circuit 38) and the predetermined known complex impedance of the circuit 38.

FIG. 3 is a flowchart showing a method for complex impedance compensation in accordance with the present invention. The method begins in step 54.

Step 54 involves the step of providing a circuit (e.g., the circuit 38) having a known, predetermined complex impedance at a predetermined frequency of interest (see above description of the predetermined frequency). The circuit 38 may be located in the handle of a catheter, or in the distal end of a connecting cable. The criteria for locating the circuit 38 is to include as much of the cable, preferably all of the cable, in the complex impedance measurement. The method proceeds to step 56.

Step 56 involves the step of probing or exciting the circuit 38 using the pilot signal at the predetermined frequency over an electrical connection (e.g., the electrical connection 50) in the cable 40. The method proceeds to step 58.

Step 58 involves the step of measuring the combined complex impedance of the electrical connection 50 and the circuit 38. The method proceeds to step 60.

Step 60 involves the step of determining a difference between the measured complex impedance (cable plus circuit 38) and the predetermined, known complex impedance of the circuit 38. This difference may be a phase angle shift (degrees), a difference in magnitude (ohms), or both. The method then proceeds to step 62.

Step 62 involves the step of using the determined difference for compensation purposes in measurements (e.g., complex impedance measurements) conducted over other electrical connections in the same cable. For example, the complex impedance may be measured through the first electrical connection using the catheter electrode. Then, the difference may be cancelled out of such other complex impedance measurement, thereby removing the effect of the cable configuration. Through the foregoing, changes that might occur in the cable can be quantified and removed, leaving only the accurate measurement intended (e.g., the complex impedance measurement of the subject tissue).

While the first aspect for an inventive compensation scheme was described in connection with an RF ablation system, it should be understood that this aspect of the invention is not so limited, and may be employed in a variety of other configurations where a catheter and one of its electrodes is used to conduct a diagnostic or therapeutic function.

#### Determining Tissue Morphology Based on Phase Angle

In the second aspect of the invention, an apparatus and method is described for determining tissue morphology based on a phase angle and/or additionally a magnitude of the tissue's complex impedance. In the field of cardiac catheter ablation, "impedance" conventionally means the magnitude  $Z$  of the complex impedance.

In the context of RF ablation, which is typically conducted at around 500 kHz, a working assumption is that such procedures involve nearly purely resistive heating. However, there does exist a number of sources that contribute capacitance. At least three main sources of such capacitance include: (1) blood; (2) the subject tissue; and (3) an electrode (e.g., Pt/Ir)-electrolyte (blood or saline) interface. Additional sources of capacitance include any connecting wires as well as stray capacitance. When the ablation system impedance is mea-

sured (e.g., by using an LCR impedance meter), a phase angle (or reactance component) is registered in addition to a resistance component (e.g.,  $Z=R+jX$ ). The reactance due to the capacitance and inductance is typically much smaller than the resistance, and the phase angle is relatively small as well (e.g.,  $<15^\circ$ ). Accordingly, for most conventional purposes, such as determining tissue heating for example, the assumption that RF ablation conducted at ~500 kHz or similar frequencies is resistive is adequate. However, for other purposes, such as the inventive approach for detecting a tissue type, this assumption is inadequate.

Investigation has shown that the three sources of capacitances described above change differently as a function of frequency. While the reactance contributed by the blood capacitance and the electrode-electrolyte interface capacitance both decrease to zero when excited at frequencies above 20 kHz (becoming essentially resistive), this is not the case with tissue. The capacitance of tissue provides a significant reactance value into the 100 kHz frequency range and does not decrease to near zero until above 500 kHz or higher, which is believed due to cell membranes contributing capacitance.

During cardiac catheter ablation, one of a plurality of different tissue types may be encountered. In the context of the exemplary embodiment, regular myocardium, scar and fat tissue types are typical of the types of tissue that can be encountered, although it should be understood that other tissue types may be appropriate for other embodiments according to the principles disclosed herein.

It is important to understand the underlying structure of the different tissue types and how such different structures affect its respective complex impedance characteristics. First, the cell structure for regular myocardium is different from that of other types of tissue considered herein such as scar and fat tissue. The major determinants affecting complex impedance of regular myocardial tissue are the extra-cellular and intra-cellular resistance, a gap junction conductance, and the cell membrane capacitance (already mentioned above). Regular myocardium therefore presents a moderate impedance (magnitude) and a regular phase angle value (negative). Scar tissue is common for ventricular tachycardia (VT) and is considered inexcitable and acellular. This makes the scar tissue more conductive and less capacitive due to lack of cell membrane, which results in low impedance and low phase angle (negative). Both the low impedance and the low phase angle of scar tissue are different from regular myocardium. Finally, fatty tissue is considered non-conductive because of the fat content, and accordingly has even higher impedance than myocardium. Fat, however, has a lower phase value because no capacitive cell membrane is present. It should be understood that the impedance (magnitude) and phase angle values for these tissue types are relative to each other. Accordingly, no specific values are necessary.

Based on the foregoing, a correlation can be made between the phase angle, on the one hand, and the tissue type, on the other hand. More specifically, based on both impedance  $|Z|$  and the phase angle  $\phi$ , a tissue type can be determined for tissue near a measurement electrode(s), as set forth in Table 1.

TABLE 1

|                    | Magnitude (Impedance) $ Z $ | Phase Angle $\phi$ |
|--------------------|-----------------------------|--------------------|
| Regular myocardium | Medium                      | High               |
| Scar/ischemia      | Low                         | Low                |
| Fat                | High                        | Low                |

Thus, using the foregoing measurement technique, a high impedance and low phase angle indicates fatty tissue. Alternatively, low impedance and low phase angle indicates a scar. Moderate impedance value (i.e. between fat and scar) and a



high phase angle value indicate normal myocardium. It is important to note that phase angle values in the aforementioned paragraphs are all negative, such that a high phase angle means more negative phase angle.

According to this aspect of the invention, use of the phase angle  $\phi$  in distinguishing tissue types is preferred because it exhibits a different and unique response for each tissue type: regular myocardium, scar and fat. Additionally, the complex magnitude (“impedance”)  $|Z|$  may be further used as well to distinguish regular tissue from irregular tissue, or even scar from fat, based on the particular values of the impedance measurements. Normally, fat is more resistive than scar tissue and this property can be used to differentiate scar from fat.

FIG. 4 is a simplified block diagram of an apparatus **100** configured to determine a tissue type based on a phase angle and/or magnitude of a measured complex impedance of the tissue. The apparatus **100** is configured for use with a catheter system **102** (partially illustrated) that includes a first electrode **104**. The catheter system **102** is configured to position the first electrode **104** so as to be in contact with the body tissue whose type is to be identified. The magnitude and phase angle measurements are dependent on the electrode contact level. Therefore, to enhance the electrode contact level and thus assure accurate complex impedance measurements, the first electrode **104** is preferably, although not exclusively, contemplated to be relatively small in size, such as the following (or smaller): between a Five French (5 Fr) and Ten French (10 Fr) in diameter, more preferably a Five French (5 Fr) in diameter, and between 2 and 8 mm in length. FIG. 4 further shows a second electrode, which in a first embodiment is a reference electrode **106**, such as a ground patch or the like, that is relatively large in size compared to the first electrode **104**. Patch **106** may be of the dispersive/indifferent electrode pad type. In this first embodiment (small first electrode plus patch), the complex impedance measurement being made reflects the properties of the tissue near and around the first electrode **104**. In an alternate embodiment, the second electrode may be another relatively small electrode, such as a tip electrode **108** or the like, shown in phantom line in FIG. 4. The second electrode **108** may be of the same configuration as the first electrode **104**. In this alternate embodiment (i.e., two small electrodes), the complex impedance measurement being made reflects the properties of the tissue between the first and second electrodes **104**, **108**. In still further embodiments, additional, relatively small electrodes similar to electrode **104** may be further included.

The apparatus **100** includes an excitation signal source **110**, a complex impedance measurement block **112**, and a tissue type identification logic block **114** configured to determine and output a tissue type **116**. The excitation signal source **110** is coupled, effectively, across the first and second electrodes **104** and **106** (or alternatively **108**) and is configured to generate the excitation signal used in determining the complex impedance. More particularly, the excitation signal, when applied across the electrodes, will produce a corresponding induced signal whose characteristics will be determined by, and thus be indicative of, the properties of the tissue under test. In one embodiment, the excitation signal has a predetermined frequency preferably between about 20 kHz or greater and 1000 kHz or less, and more preferably between about 50 kHz or greater and 500 kHz or less. The excitation signal source **110** may comprise conventional apparatus for generating such a signal (e.g., may be either a constant voltage or current at the predetermined frequency).

The complex impedance measurement block **112** is coupled, effectively, across the first and second electrodes **104** and **106** (or alternatively **108**) and is configured to deter-

mine a complex impedance therebetween, based on the measurement of the induced signal, in view of the applied excitation signal. The block **112** may comprise conventional apparatus for performing such measurements, in view of the selected nature and format of the applied excitation signal. The source **110** and the measurement block **112** may be integrated (e.g., like an LCR meter).

The block **114** is configured to identify one of a plurality of candidate tissue types based on at least one of the phase angle and/or magnitude of the tissue’s complex impedance. The block **114** is further configured to produce an output **116** reporting the identified tissue type. The block **114** may be implemented with conventional apparatus known to those of ordinary skill in the art, and may be a computer-implemented apparatus (a computer-based controller not shown) configured to operate in accord with pre-programmed instructions and data. The block **114** may thus be preconfigured to include a data structure (data structure not shown) and/or logic reflecting the relationship(s) between tissue type, on the one hand, and the expected phase angles and/or magnitudes on the other hand, such as illustrated in Table 1 for regular myocardium, scar and fat. In a preferred embodiment, the plurality of candidate tissue types includes regular myocardium, scar and fat as particularly set forth in Table 1. Practicing this aspect of the invention in software would require no more than ordinary skill in the art, in view of this enabling disclosure describing the functions to be performed. Of course, other implementations are possible, consistent with the teachings disclosed herein.

FIG. 5 is a flowchart diagram of a method of determining a tissue type. The method begins in step **118**.

Step **118** involves the step of providing a first electrode (e.g., first electrode **104**) in adequate contact with tissue where the tissue may be one of a plurality of expected, candidate tissue types. Step **118** also involves providing a second electrode, such a reference electrode patch **106** or alternatively the second electrode **108** (as described above). The method then proceeds to step **120**.

Step **120** involves the step of measuring a complex impedance between the first and second electrodes using an excitation signal having a predetermined frequency. Step **120** may include the substep of selecting a value defining what specific frequency to use, the particulars of which have been described above. Additionally, the complex impedance comprises a magnitude (“impedance”)  $|Z|$  and a phase angle  $\phi$ . The method proceeds to step **122**.

Step **122** involves the step of identifying one of the plurality of candidate tissue types based on at least one of the magnitude and/or phase angle. In the embodiment described herein involving the candidate tissue types of regular myocardium, scar and fat, the phase angle  $\phi$  is the preferred, primary parameter. The magnitude  $|Z|$  may be employed as a secondary parameter, all as described above in detail. Step **122** may further include the substep of reporting the identified tissue type. Through the foregoing, an apparatus and method is provided for determining a tissue type, based on the phase angle and/or magnitude of the tissue’s complex impedance. The apparatus and method is useful in many applications, including VT applications described above.

Although numerous embodiments of this invention have been described above with a certain degree of particularity, those skilled in the art could make numerous alterations to the disclosed embodiments without departing from the spirit or scope of this invention. All directional references (e.g., upper, lower, upward, downward, left, right, leftward, rightward, top, bottom, above, below, vertical, horizontal, clockwise, and counterclockwise) are only used for identification pur-



## 11

poses to aid the reader's understanding of the present invention, and do not create limitations, particularly as to the position, orientation, or use of the invention. Joinder references (e.g., attached, coupled, connected, and the like) are to be construed broadly and may include intermediate members between a connection of elements and relative movement between elements. As such, joinder references do not necessarily infer that two elements are directly connected and in fixed relation to each other. It is intended that all matter contained in the above description or shown in the accompanying drawings shall be interpreted as illustrative only and not limiting. Changes in detail or structure may be made without departing from the spirit of the invention as defined in the appended claims.

What is claimed is:

1. An apparatus for use with a catheter having an electrode at a distal end thereof and a handle at a proximal end thereof, and a cable for making a first electrical connection between an electrical device and a proximal end of the handle, the catheter further including a lead electrically connected to the electrode and different from the first electrical connection in the cable, the lead being configured to be coupled to the first electrical connection in the cable so as to allow the device through the first electrical connection and the lead to electrically interact with the electrode, said apparatus comprising:

a circuit having a predetermined known complex impedance responsive to a pilot signal having a predetermined frequency, said circuit being disposed in one of said handle of said catheter and a distal end of said cable in a cable connector interface that is configured to be coupled to said handle, said circuit being electrically connected to said first electrical connection when said cable is coupled to said handle;

a compensation control configured to generate said pilot signal, said cable being further configured to make a second electrical connection between the compensation control and said circuit wherein said second electrical connection is independent of said first electrical connection, said compensation control being further configured to measure a complex impedance of said second electrical connection and said circuit responsive to said pilot signal, said compensation control is further configured to produce a difference signal indicative of a difference between said measured complex impedance and said predetermined, known complex impedance.

2. The apparatus of claim 1 wherein said circuit is one of a loop-back circuit, a series-connected resistor circuit, series-connected resistor-inductor (RL) circuit, a series-connected resistor-capacitor (RC) circuit, a series-connected resistor-inductor-capacitor (RLC) circuit, a parallel-connected RL circuit, a parallel-connected RC circuit, a parallel-connected RLC circuit and a combination of one or more of the foregoing.

3. The apparatus of claim 1 wherein said electrical device is a radio frequency (RF) ablation generator, said electrode is an ablation electrode.

4. The apparatus of claim 1 wherein said difference signal is a phase angle offset.

5. The apparatus of claim 4 wherein said electrical device is an ablation generator that includes a complex impedance

## 12

determining circuit configured to measure a complex impedance using said electrode and based on said phase angle offset.

6. The apparatus of claim 1 wherein said electrical device is an ablation generator having an operating frequency range between 50 kHz and 500 kHz, said predetermined frequency of said pilot signal being no less than about 6 kHz and no greater than about 50 kHz.

7. The apparatus of claim 6 wherein said predetermined frequency is about 20 kHz.

8. The apparatus of claim 1 wherein said compensation control includes a phase detector configured to produce said difference signal.

9. The apparatus of claim 8 wherein said electrical device is an ablation generator that includes a complex impedance determining circuit configured to measure a complex impedance using said electrode and responsive to said difference signal.

10. A method of operating an electrical device with a catheter having an electrode at a distal end thereof and a handle at a proximal end thereof, and a cable for making a first electrical connection between the electrical device and a proximal end of the handle, the catheter further including a lead electrically connected to the electrode and different from the first electrical connection in the cable, the lead being configured to be coupled to the first electrical connection in the cable and the lead of the catheter to electrically interact with the electrode, said method comprising:

providing a circuit with a first predetermined known complex impedance when excited by a pilot signal having a predetermined frequency, said circuit being disposed in one of said handle of said catheter and a distal end of said cable in a cable connector interface that is configured to be coupled to said handle, said circuit being electrically connected to said first electrical connection when said cable is coupled to said handle;

exciting the circuit with the pilot signal over a second electrical connection in the cable that is independent of said first electrical connection in the cable;

measuring a second complex impedance of a combination of the second electrical connection and the circuit;

determining a difference between the measured complex impedance and the predetermined known complex impedance; and

operating the electrical device in accordance with the difference.

11. The method of claim 10 wherein said electrical device comprises an ablation generator and said electrode comprises an ablation electrode, and wherein said operating step includes the substep of:

measuring a third complex impedance over the first electrical connection using the ablation electrode indicative of the combined impedance of tissue in contact with the electrode and the first electrical connection;

determining a fourth complex impedance associated with the tissue based on the measured third complex impedance and the determined difference.

12. The method of claim 10 wherein said step of providing the circuit includes the substep of:

locating the circuit in one of said handle of the catheter and a distal end of the cable configured to be coupled to said handle.

\* \* \* \* \*