



US008270872B2

(12) **United States Patent**
Takiguchi et al.

(10) **Patent No.:** **US 8,270,872 B2**
(45) **Date of Patent:** **Sep. 18, 2012**

(54) **IMAGE FORMING APPARATUS HAVING A CONNECTING MECHANISM BETWEEN PHOTORECEPTOR ASSEMBLY AND DEVELOPING ASSEMBLY**

2004/0190936 A1 9/2004 Yoshiyuki et al.
2005/0123319 A1 6/2005 Mizoguchi 399/111
2007/0206971 A1 9/2007 Yoshino 399/111

(75) Inventors: **Toshio Takiguchi**, Saitama (JP); **Takuji Matsumoto**, Saitama (JP)

(73) Assignee: **Fuji Xerox Co., Ltd.**, Tokyo (JP)

(*) Notice: Subject to any disclaimer, the term of this patent is extended or adjusted under 35 U.S.C. 154(b) by 454 days.

FOREIGN PATENT DOCUMENTS		
JP	1-85734	6/1989
JP	2-244075	9/1990
JP	04-046355	2/1992
JP	04-066961	3/1992
JP	04-110975	4/1992
JP	5-232752	9/1993
JP	6-35247	2/1994
JP	09-127851	5/1997
JP	10-186851	7/1998

(Continued)

(21) Appl. No.: **12/557,151**

(22) Filed: **Sep. 10, 2009**

(65) **Prior Publication Data**
US 2010/0209137 A1 Aug. 19, 2010

(30) **Foreign Application Priority Data**
Feb. 17, 2009 (JP) P2009-034200

(51) **Int. Cl.**
G03G 21/18 (2006.01)

(52) **U.S. Cl.** **399/114**

(58) **Field of Classification Search** 399/102,
399/103, 105, 106, 111, 113, 114
See application file for complete search history.

(56) **References Cited**

U.S. PATENT DOCUMENTS

4,766,455 A *	8/1988	Carter	399/116
6,993,267 B2 *	1/2006	Yoshiyuki et al.	399/114
7,532,841 B2 *	5/2009	Tanaka	399/114
7,929,881 B2 *	4/2011	Yoshino et al.	399/113
8,055,154 B2 *	11/2011	Iikura et al.	399/111
8,095,036 B2 *	1/2012	Yoshino et al.	399/114

OTHER PUBLICATIONS

Japanese Office Action dated Jun. 7, 2011.

Primary Examiner — Robert Beatty
(74) *Attorney, Agent, or Firm* — Sughrue Mion, PLLC

(57) **ABSTRACT**

An image forming assembly includes a photoreceptor assembly that includes a photoreceptor, and an accommodating container that accommodates at least the photoreceptor and holds the photoreceptor with a part of the photoreceptor being exposed; a developing assembly that includes a developing member, and a developer container that accommodates at least the developer member and holds the developing member so as to position the developing member at a portion opposed to the photoreceptor; a connecting mechanism that connects the photoreceptor assembly to the developing assembly so that a distance between the photoreceptor and the developing member is changeable; a protection member that covers and protects the exposed portion of the photoreceptor; and guide members that are respectively provided on the accommodating container and the developer container, and that detachably guide the protection member with the protection member lying astride the two assemblies.

14 Claims, 27 Drawing Sheets

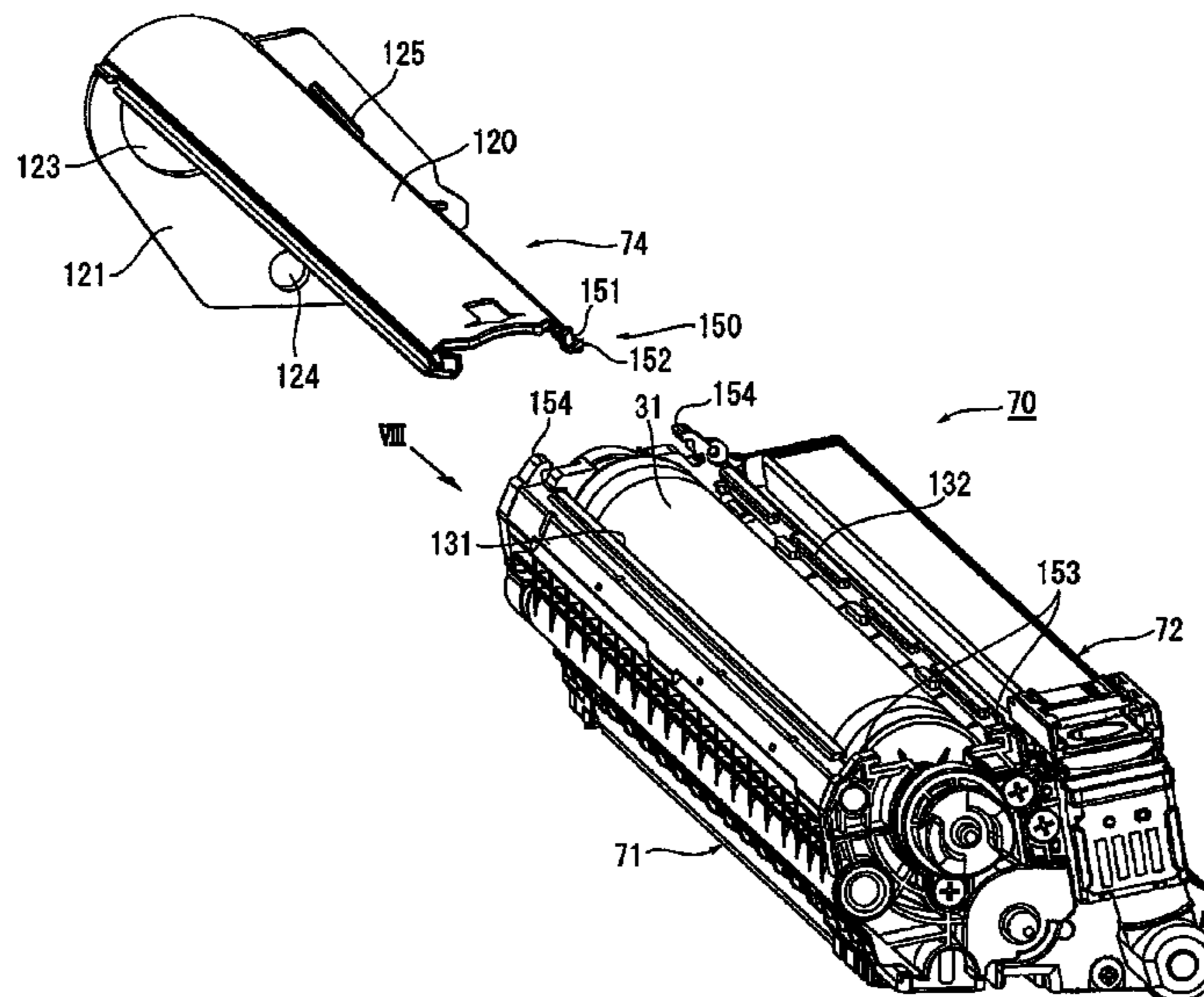

US 8,270,872 B2

Page 2

FOREIGN PATENT DOCUMENTS					
			JP	2004-170904	6/2004
			JP	2004-280012	10/2004
JP	2000-181328	6/2000	JP	2005-141140	6/2005
JP	2000181326 A *	6/2000	JP	2007-233240	9/2007
JP	2000-258979	9/2000	JP	2008-015022	1/2008
JP	2001-282079	10/2001	JP	2008-170950	7/2008
JP	2002-182541	6/2002			
JP	2003-173076	6/2003			
JP	2003-195614	7/2003			

* cited by examiner

FIG. 1A

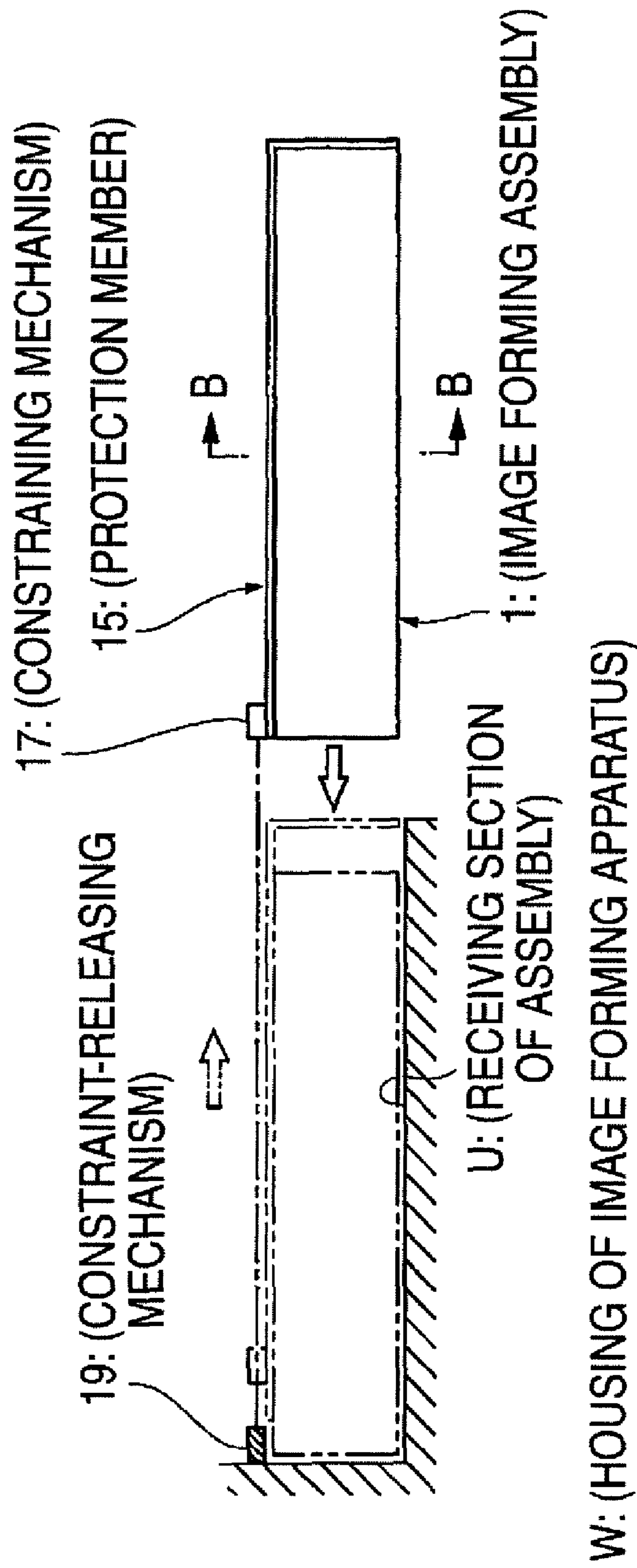

FIG. 1B

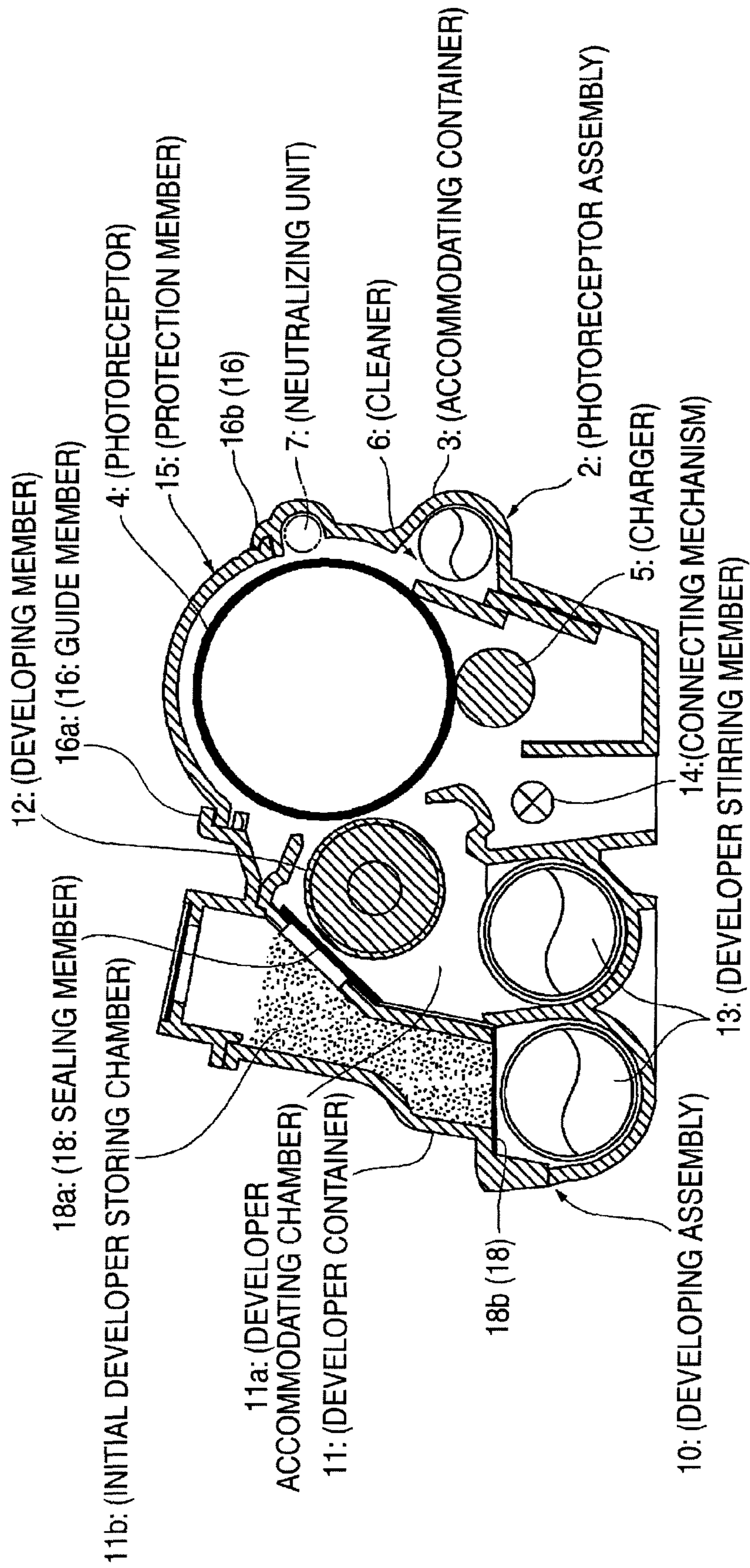

FIG. 2A

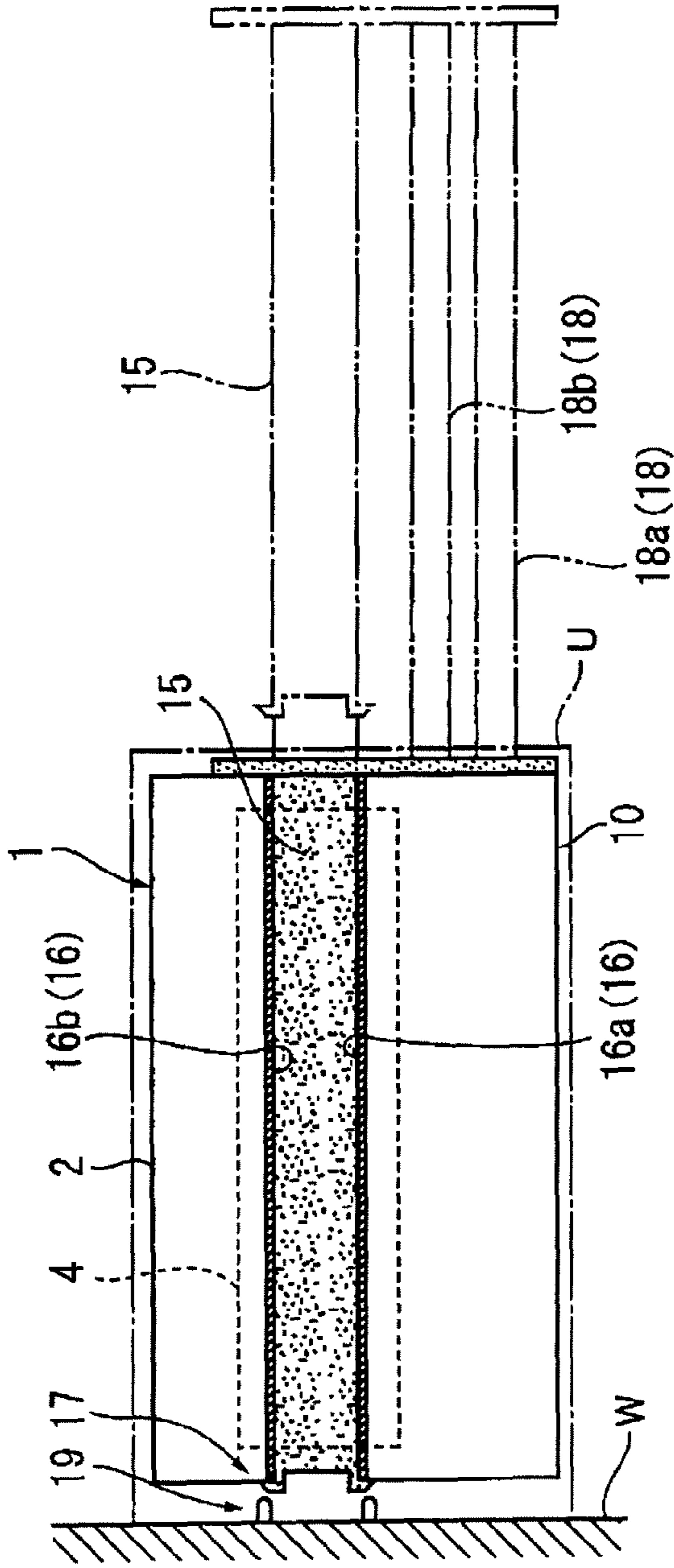

FIG. 2B

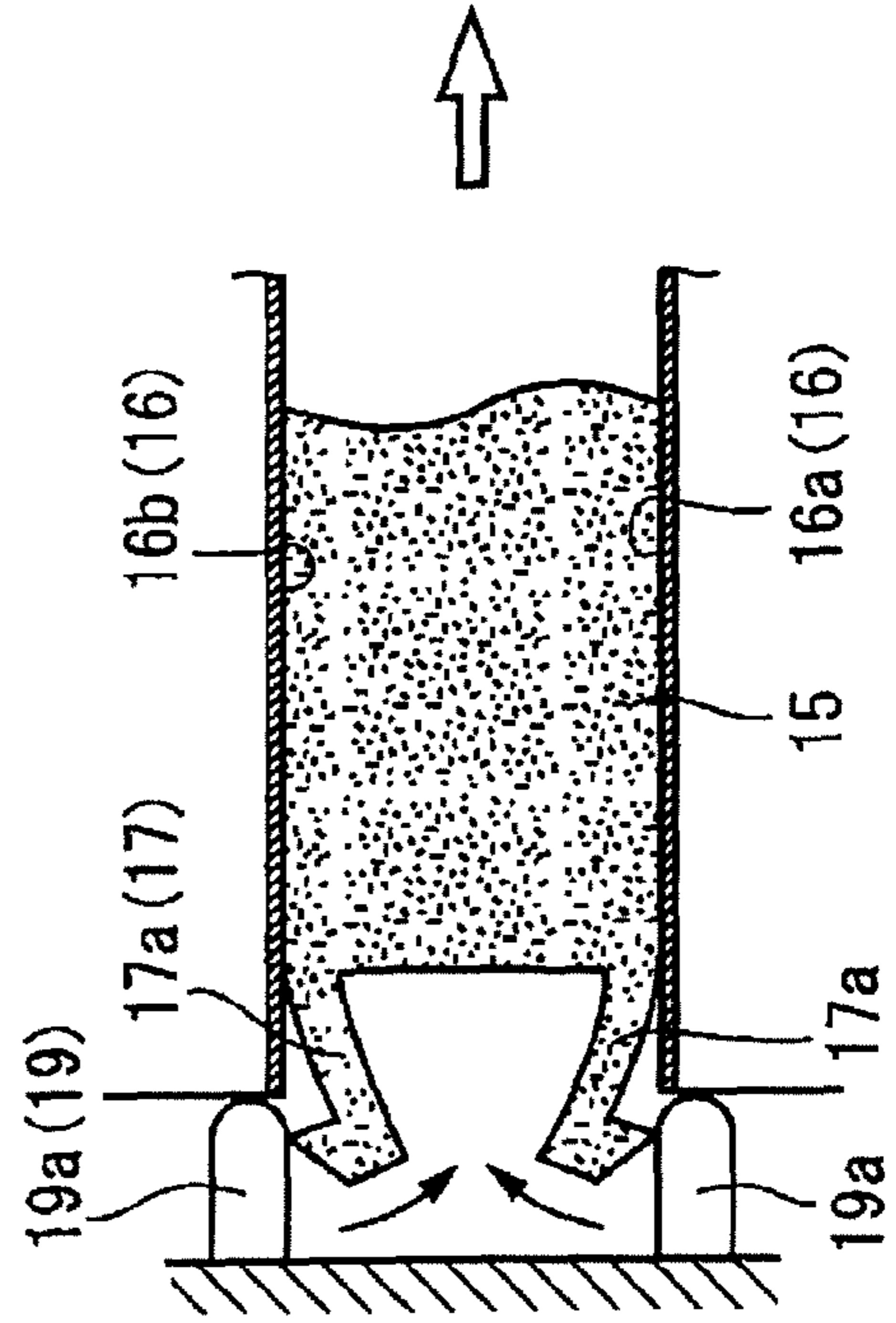
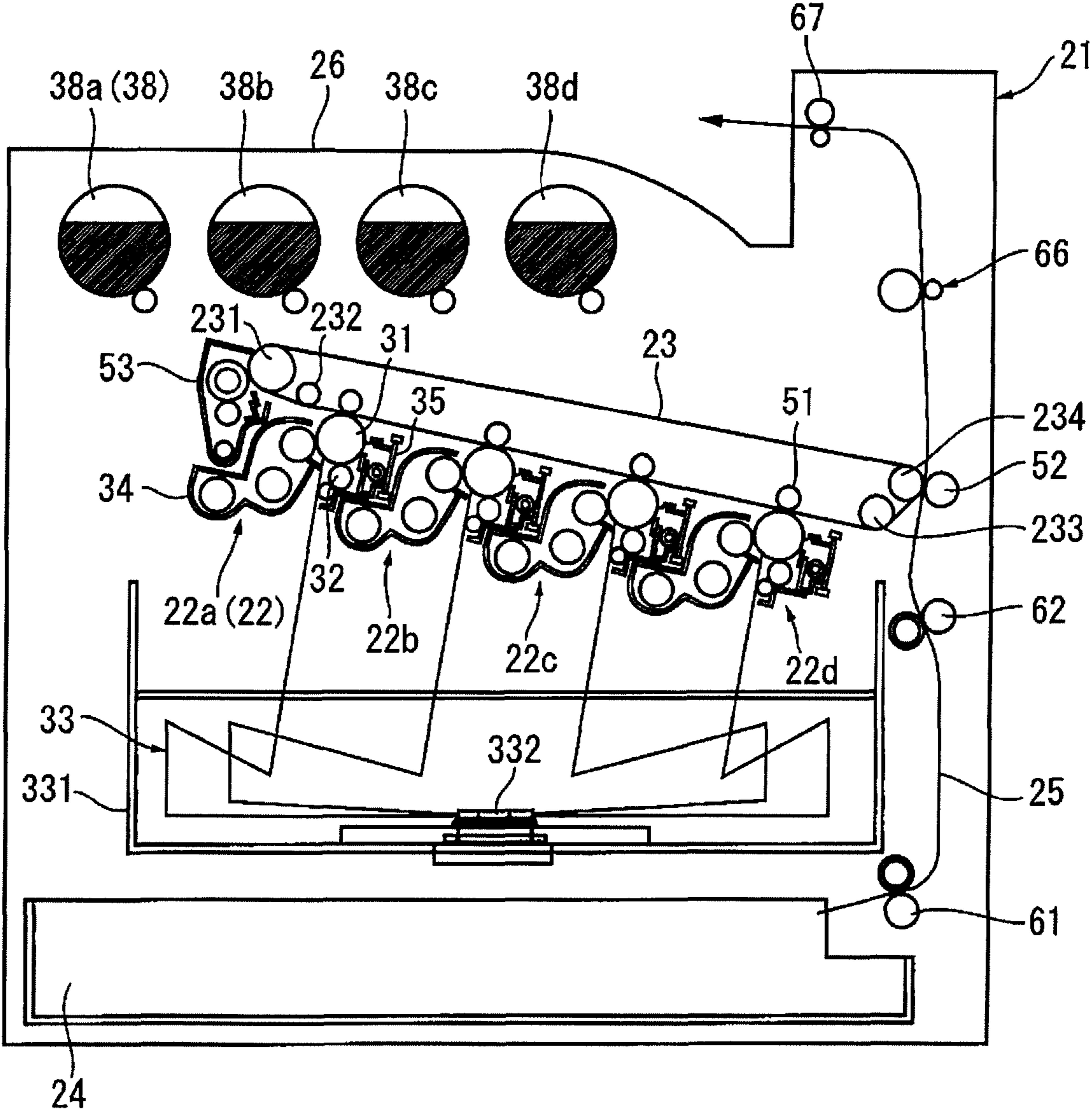
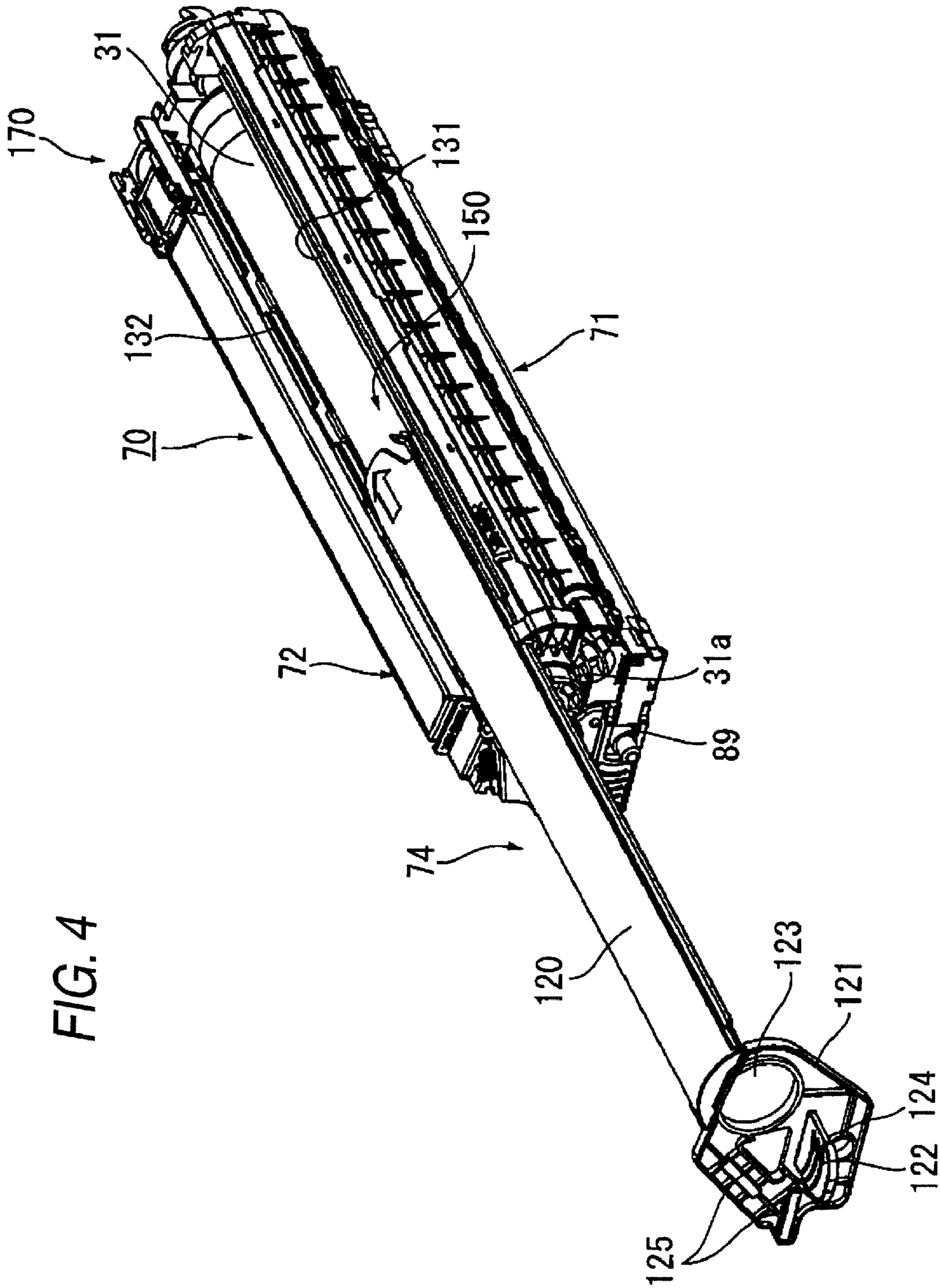

FIG. 3





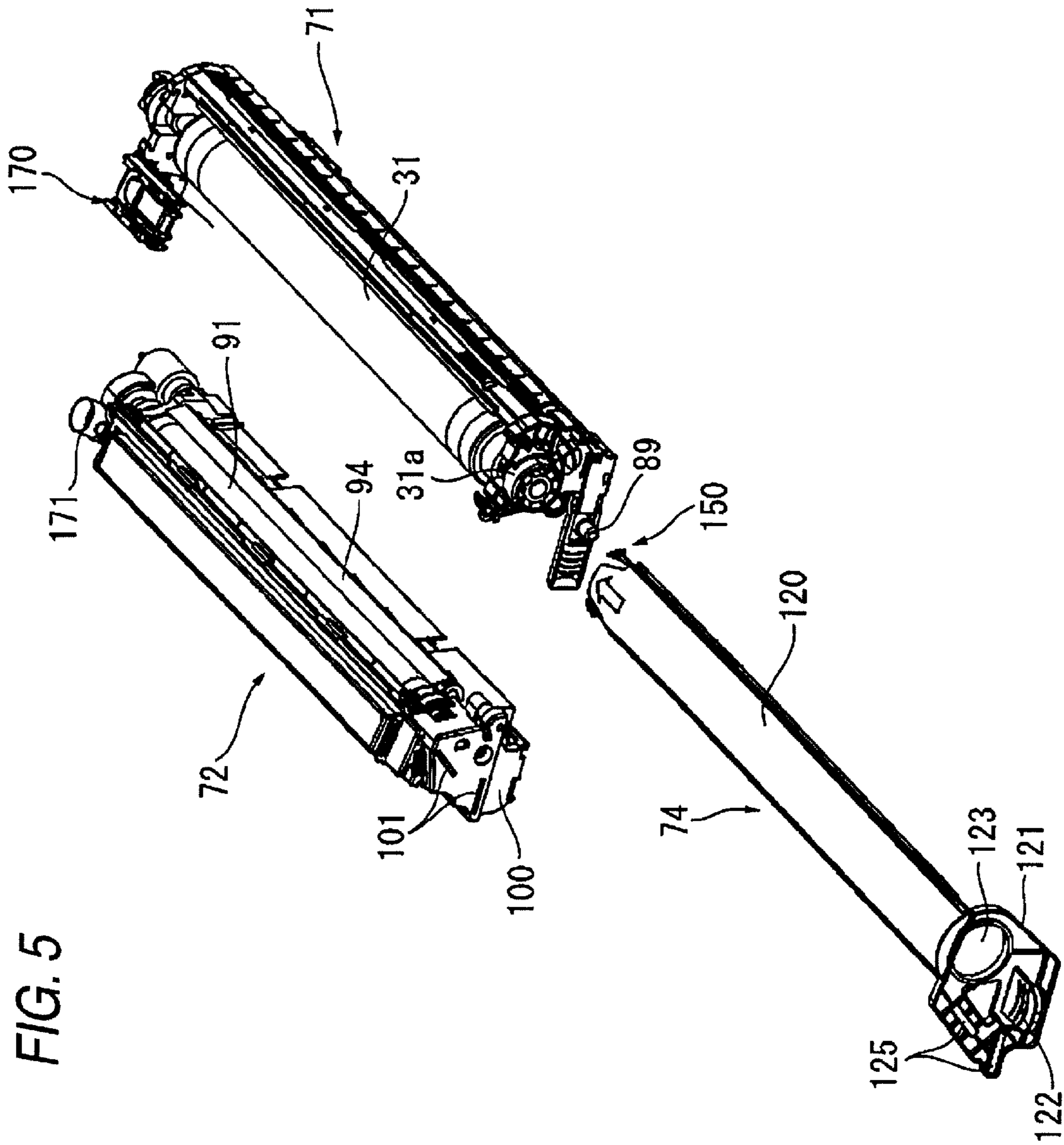

FIG. 5

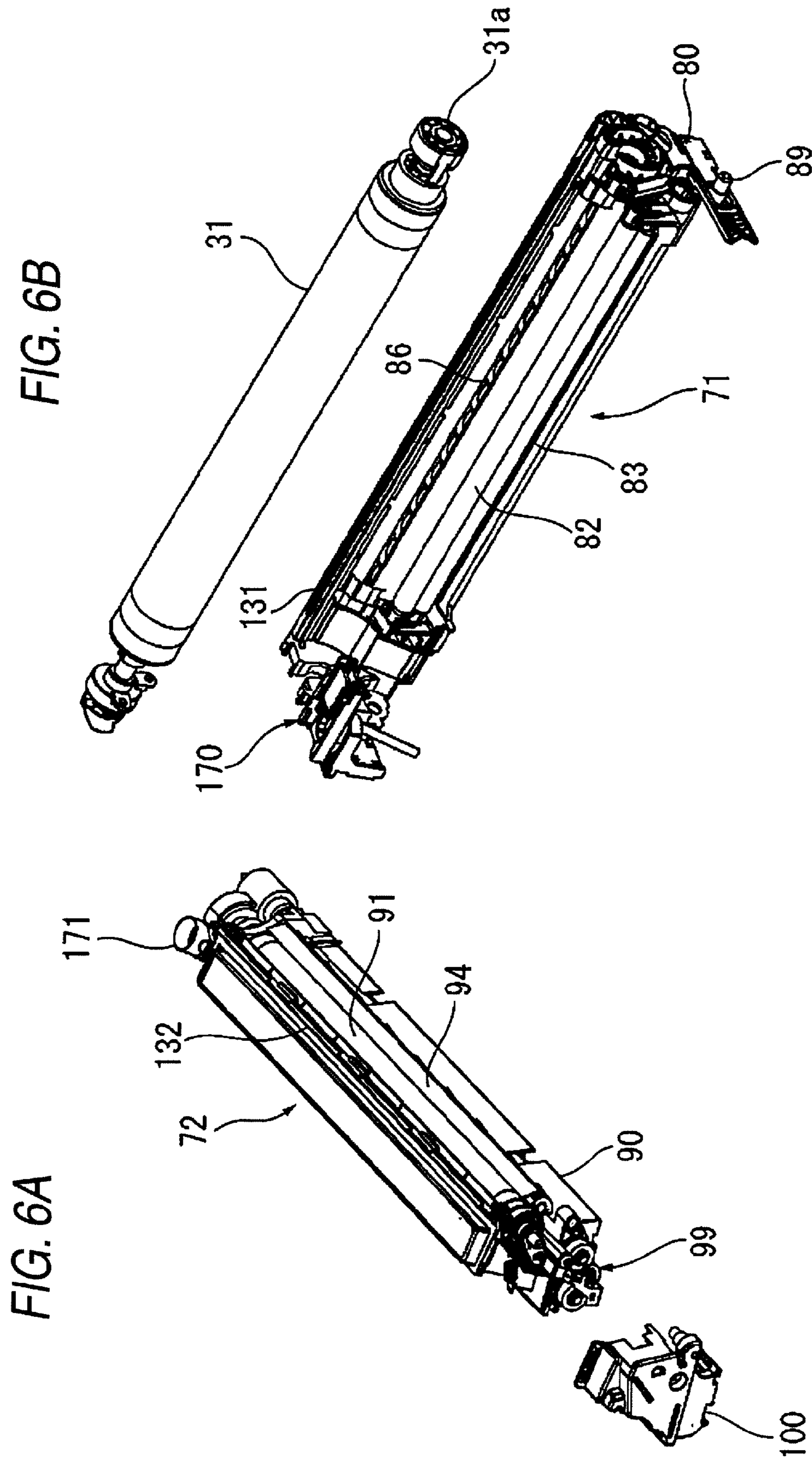
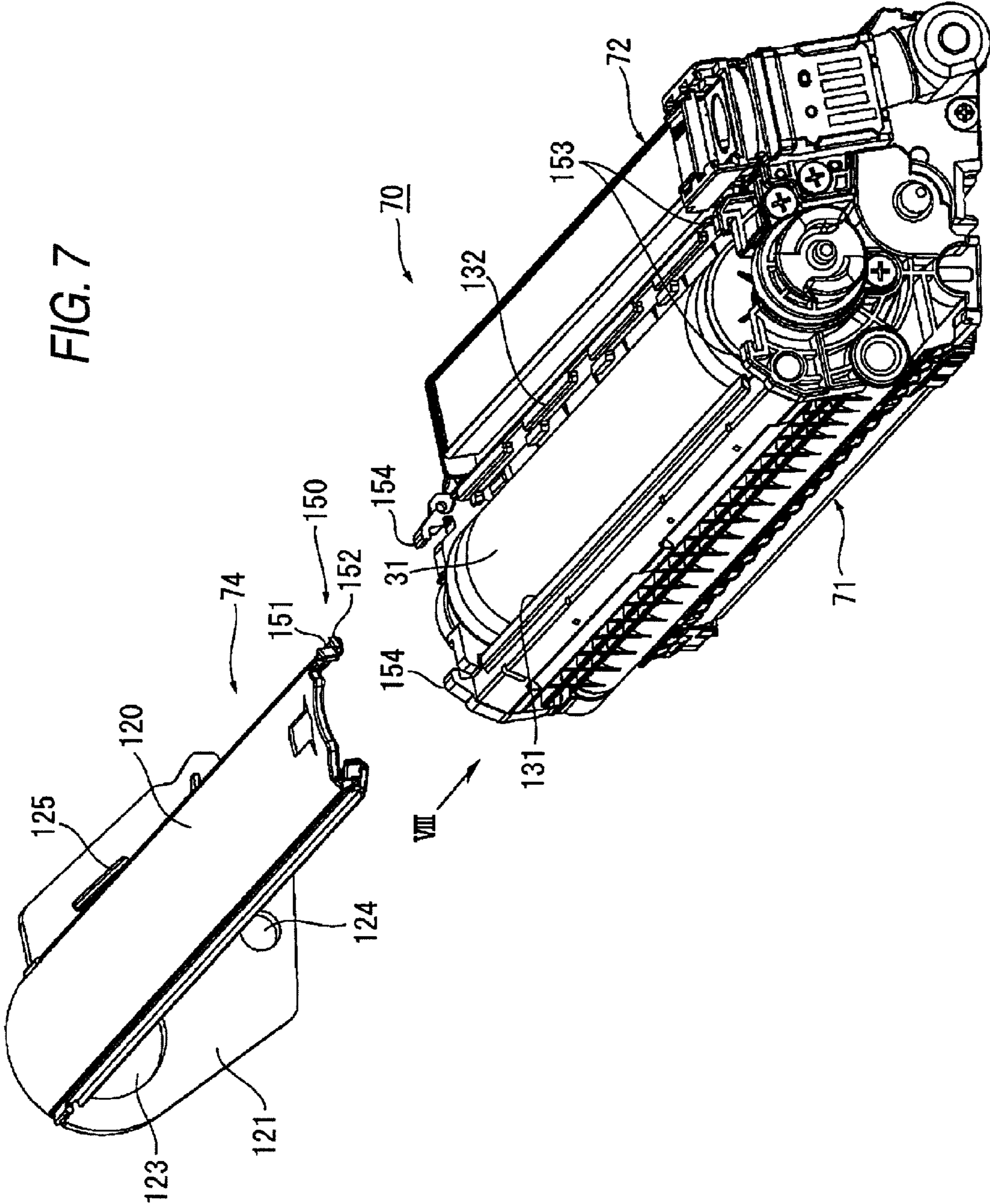

FIG. 7



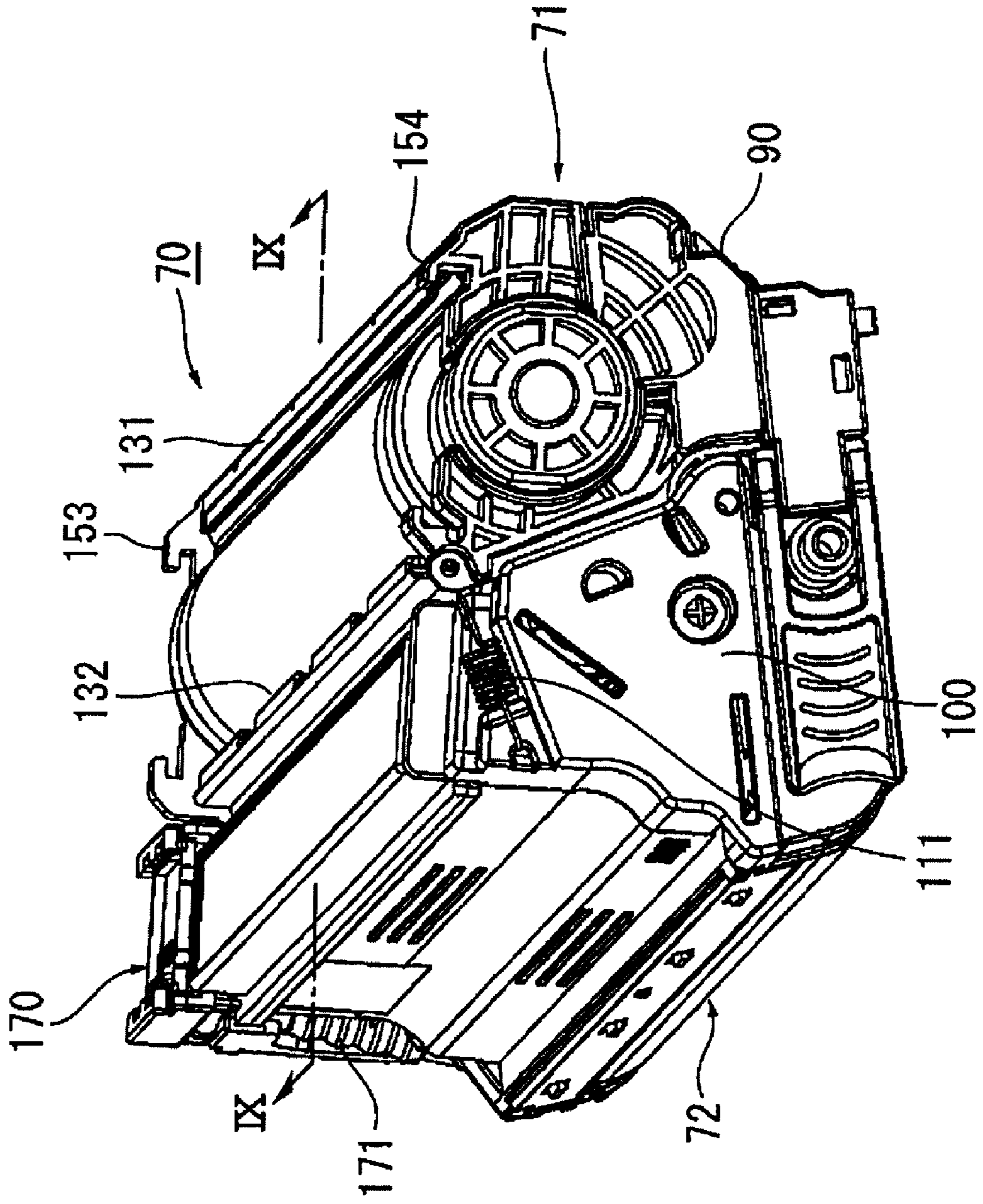

FIG. 8

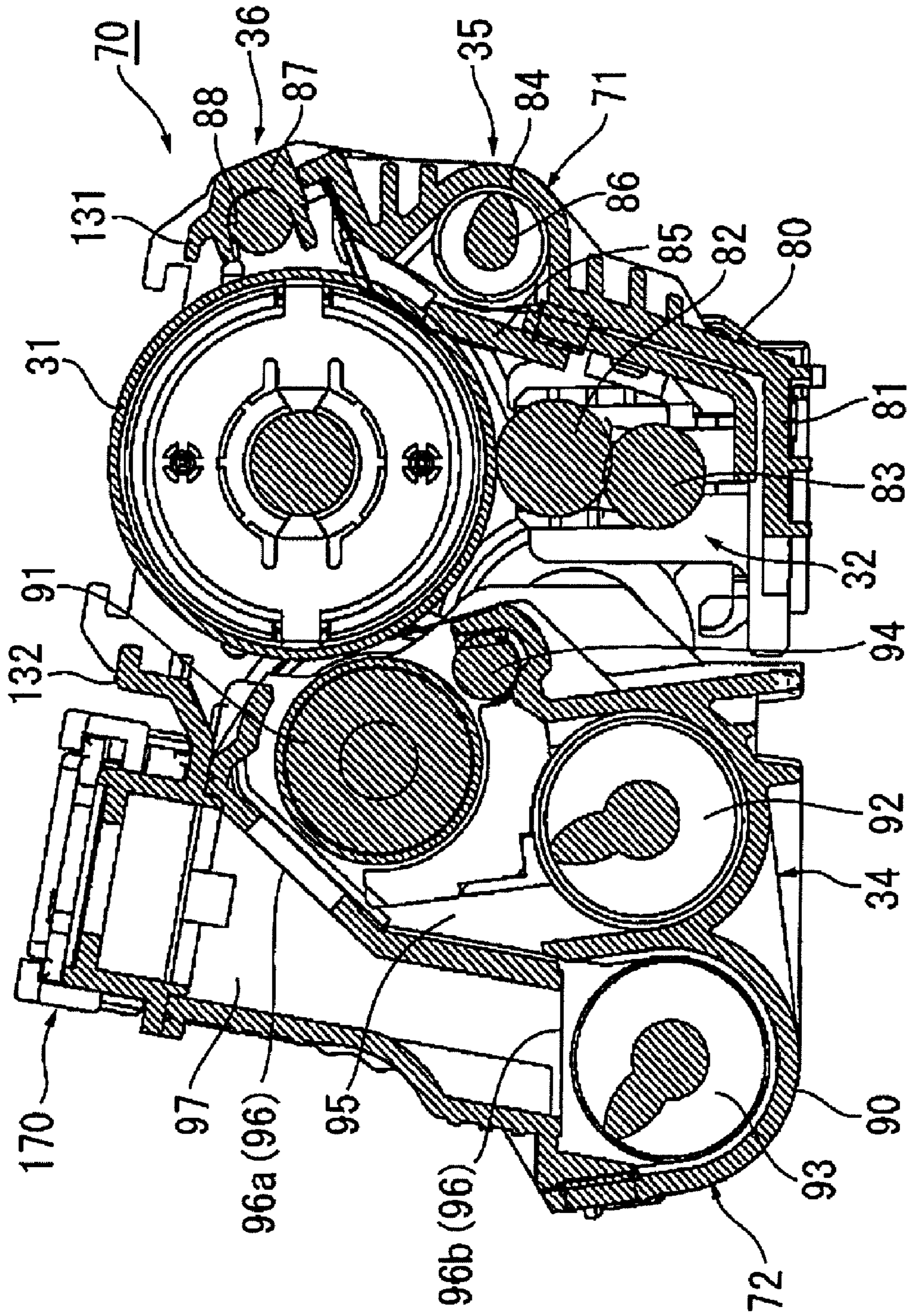

FIG. 9

FIG. 10

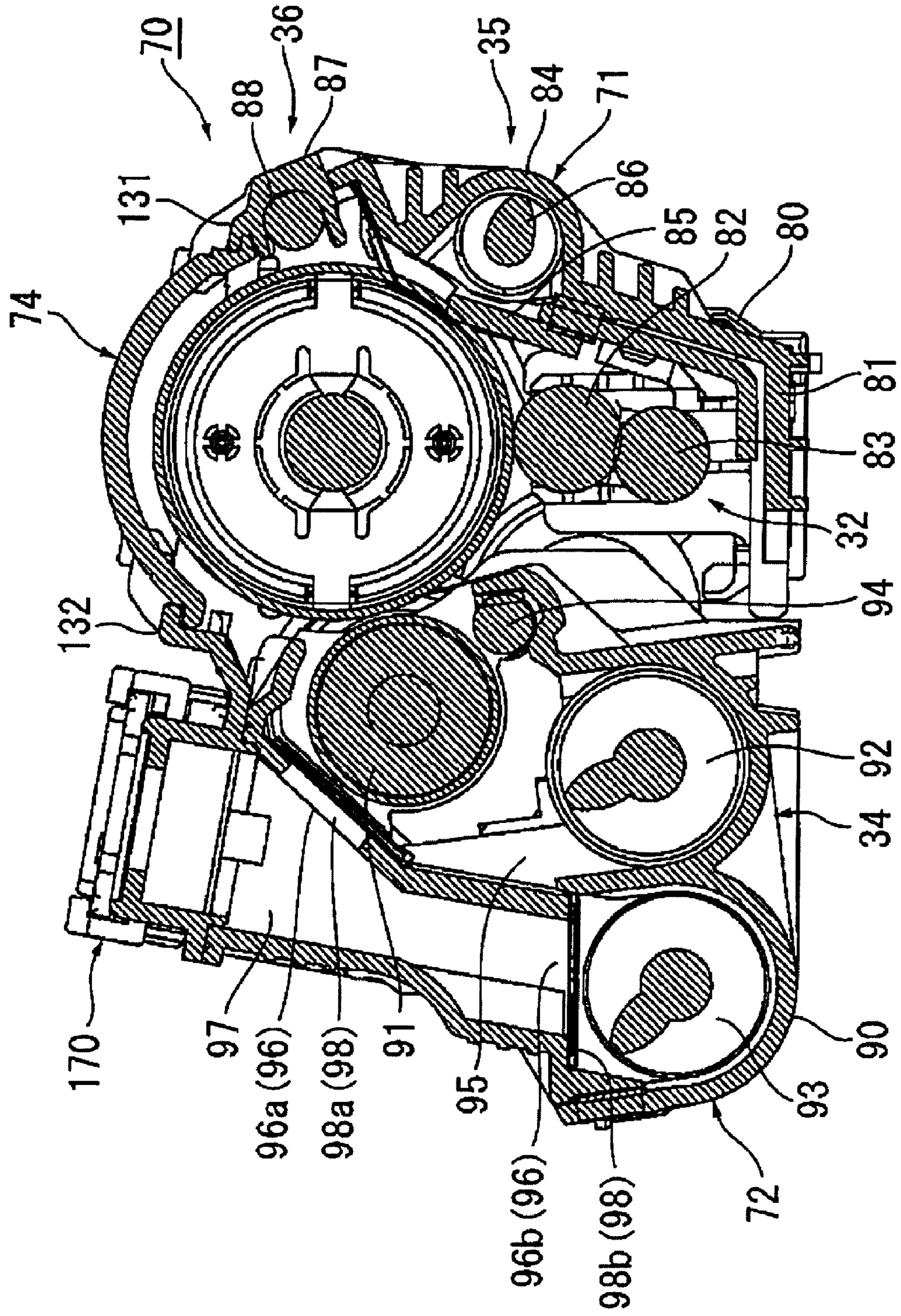

FIG. 11A

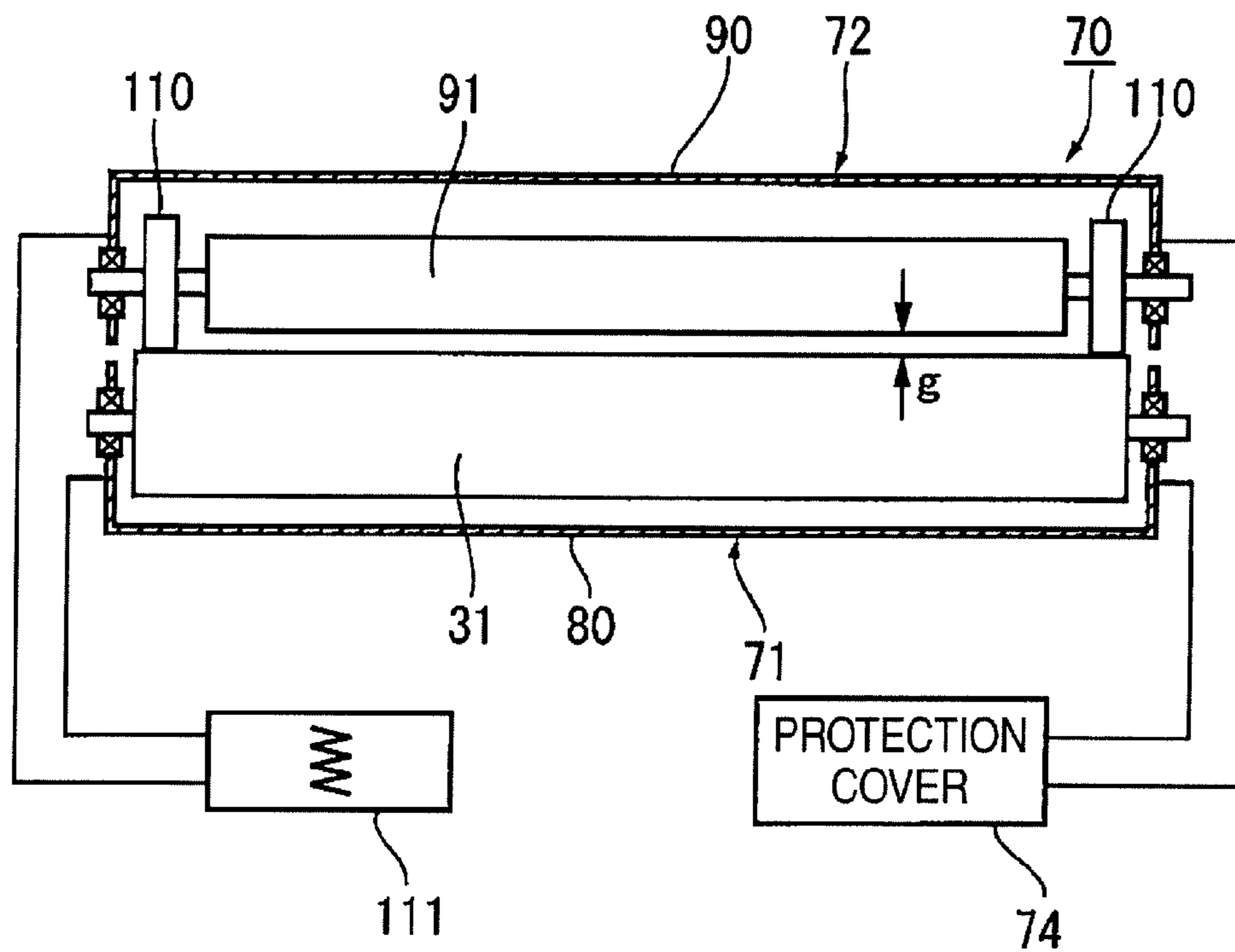
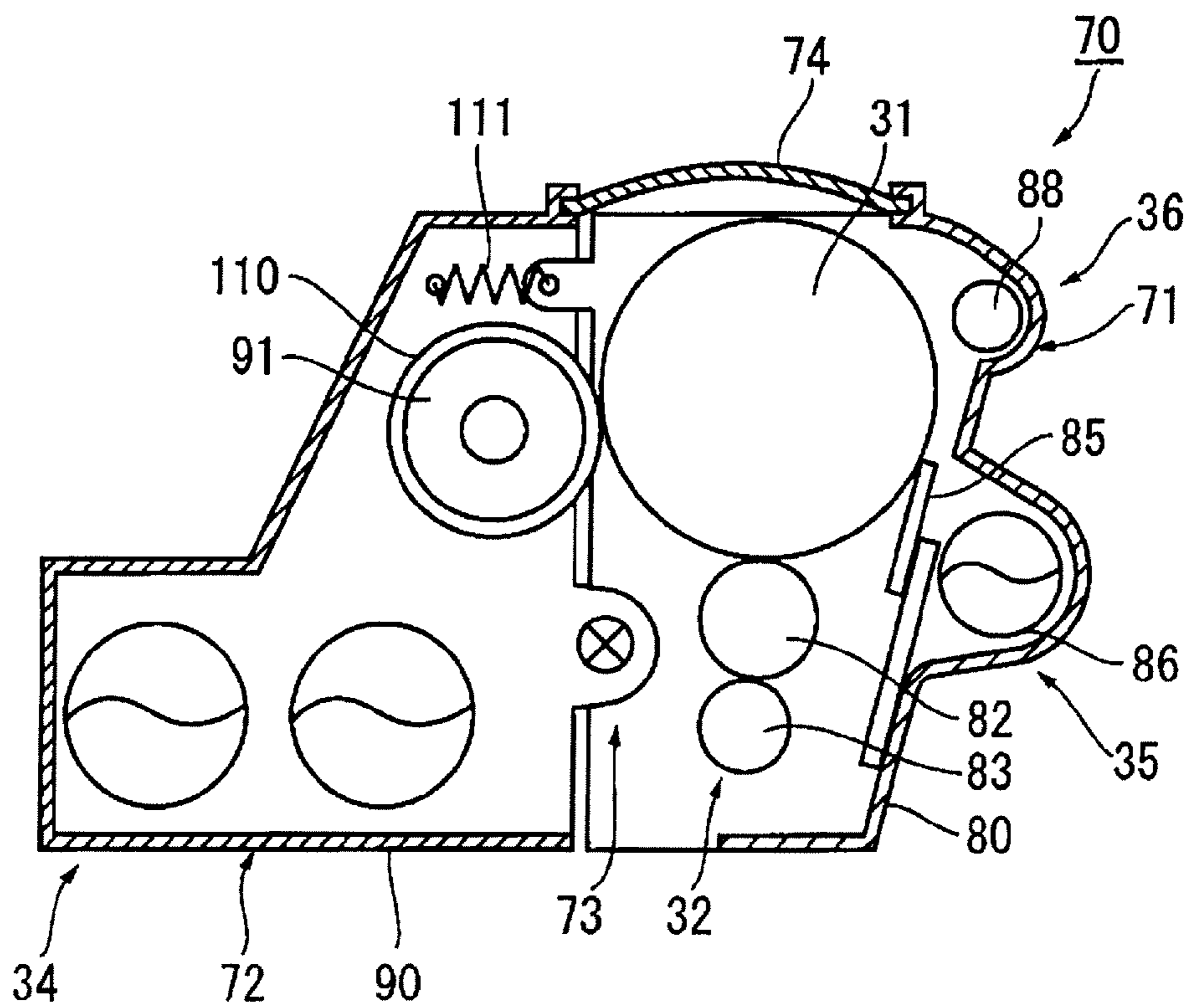

FIG. 11B



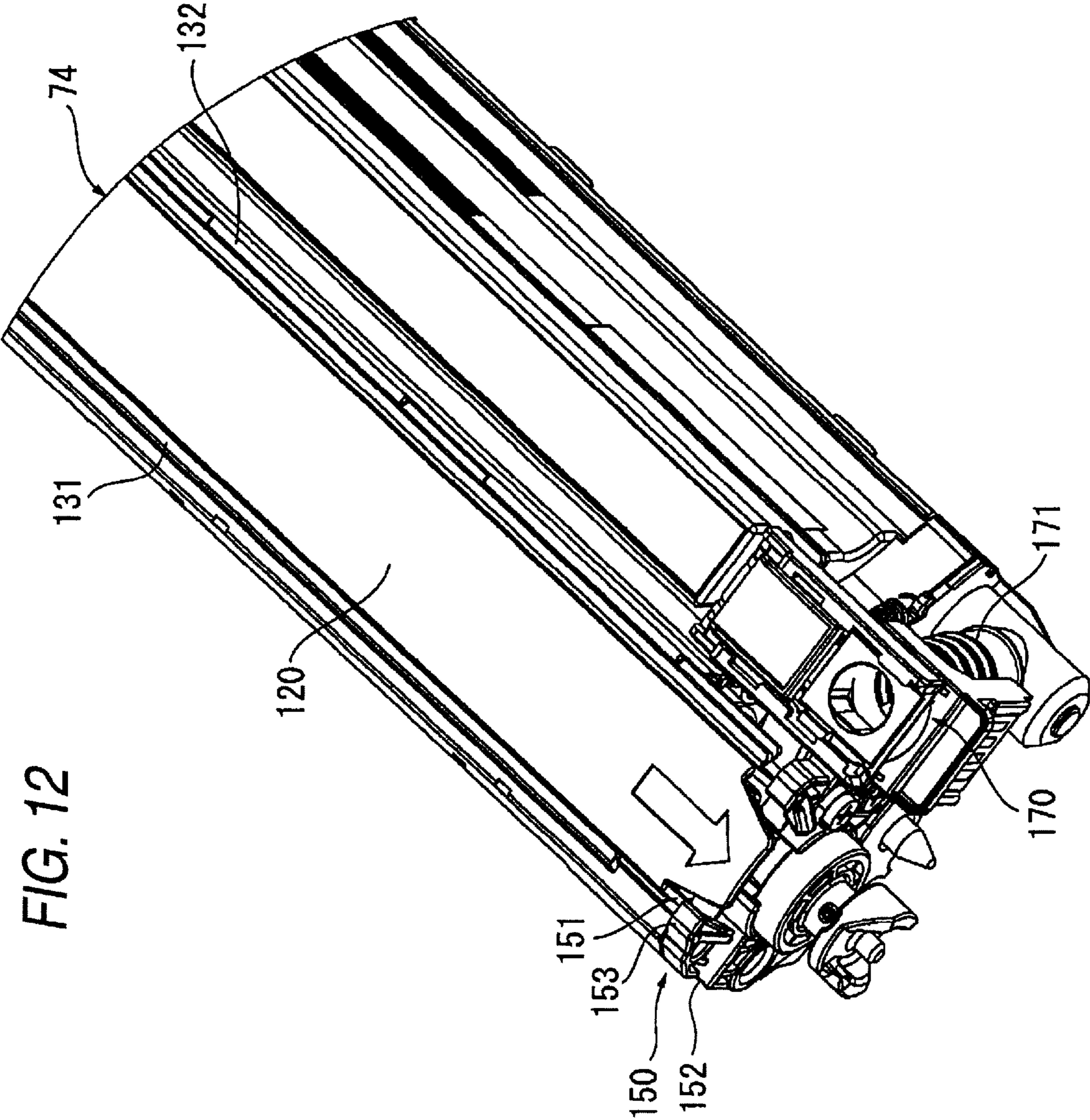

FIG. 12

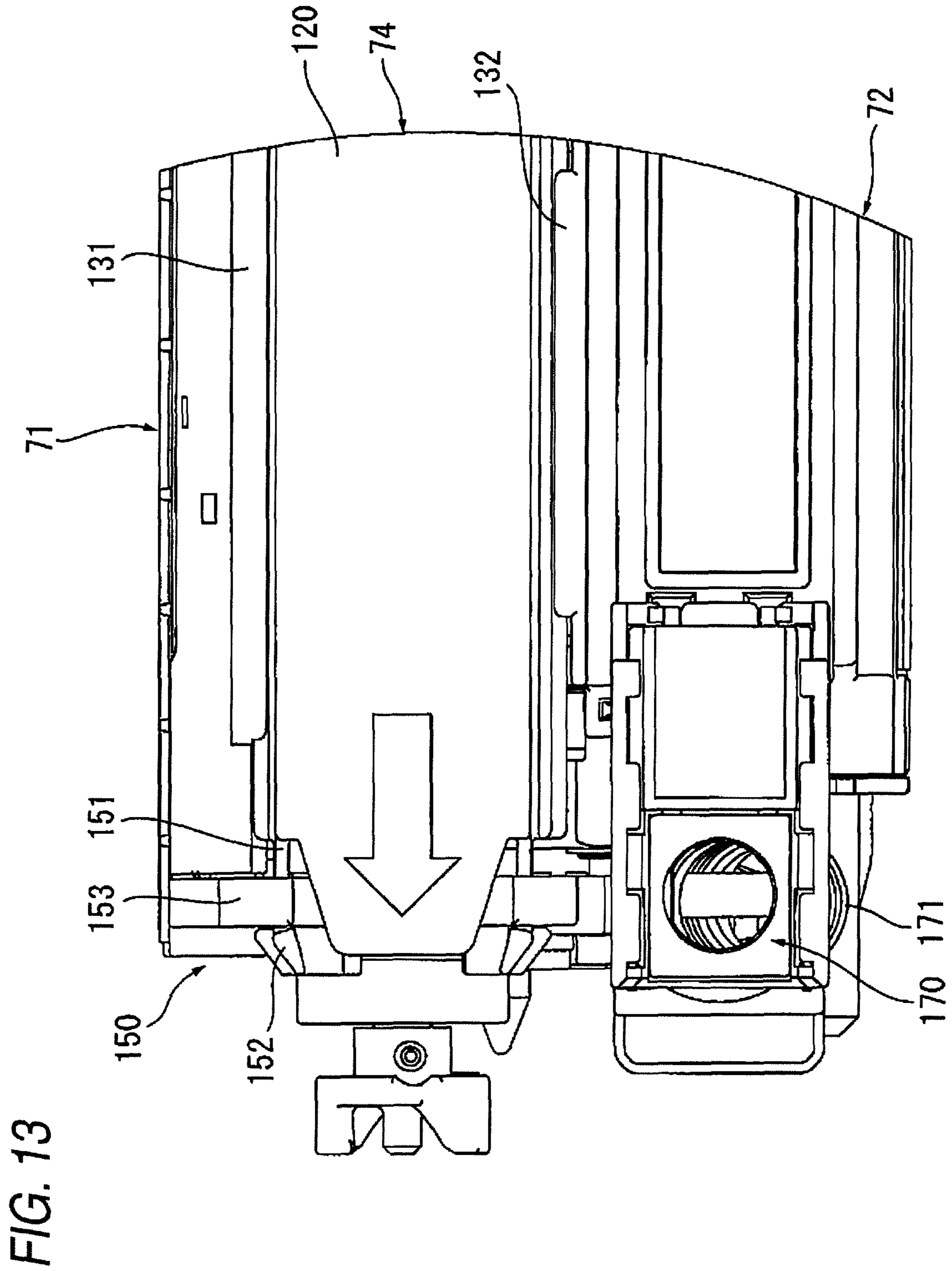

FIG. 13

FIG. 14A

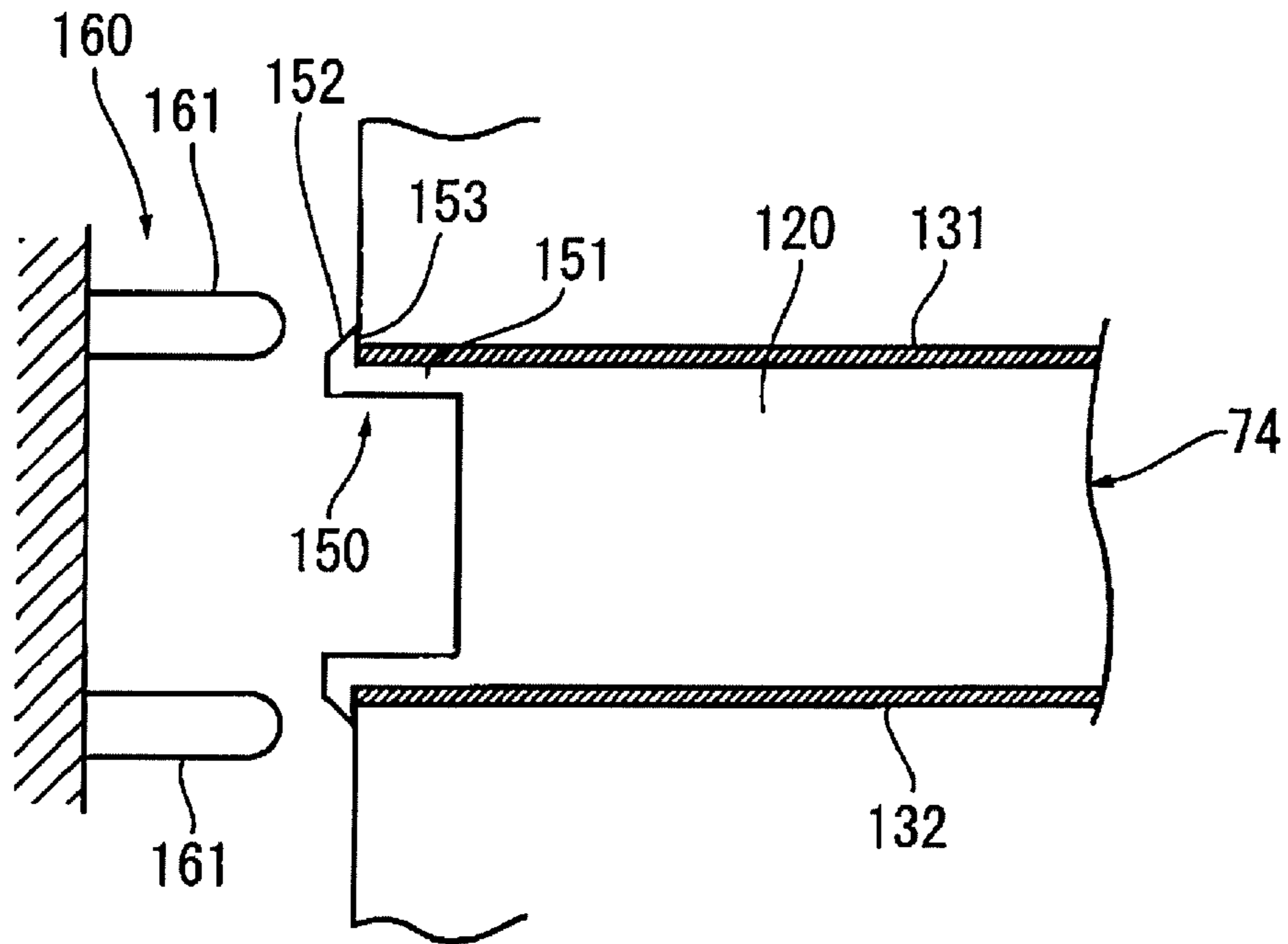

FIG. 14B

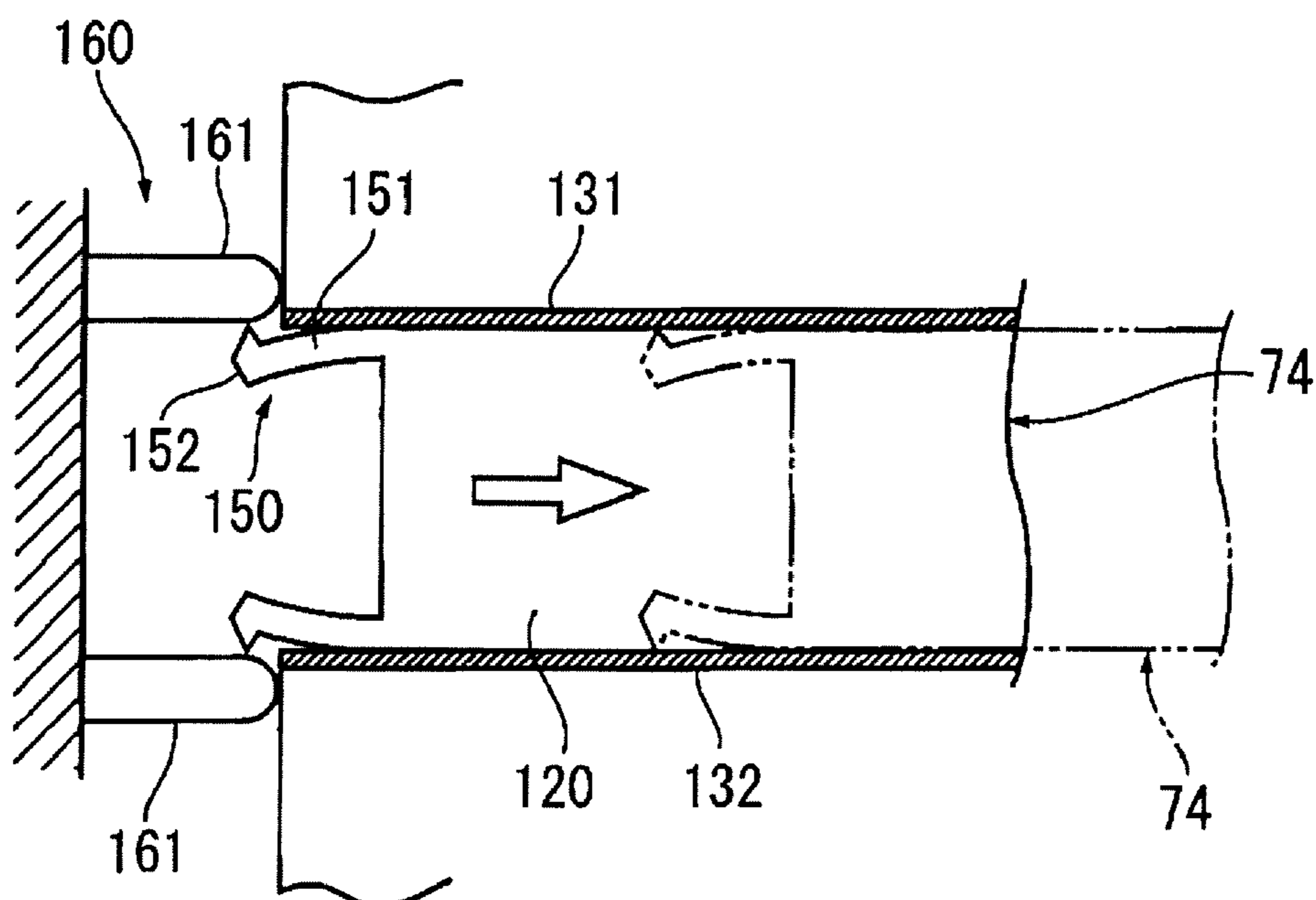

FIG. 15A

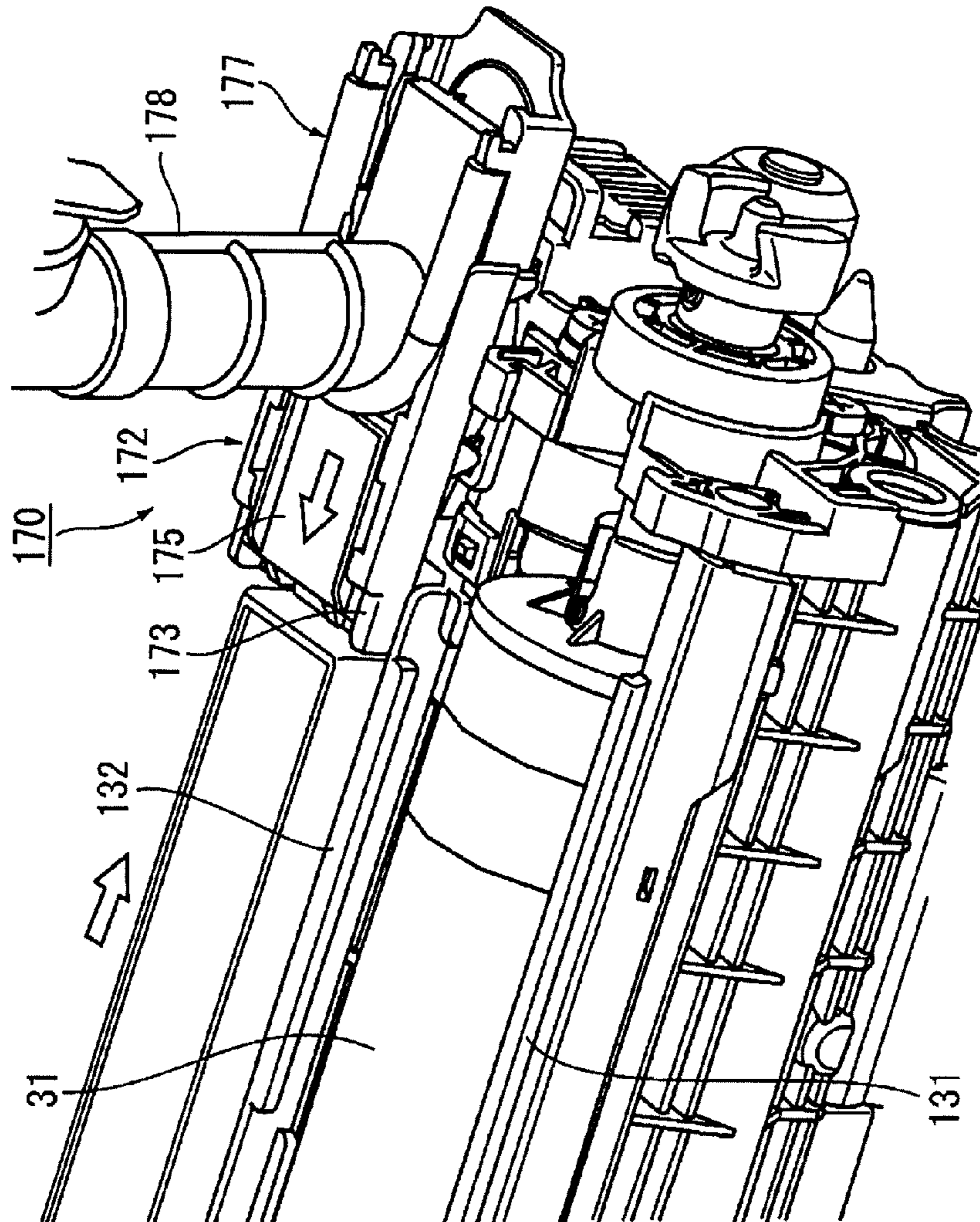

FIG. 15B

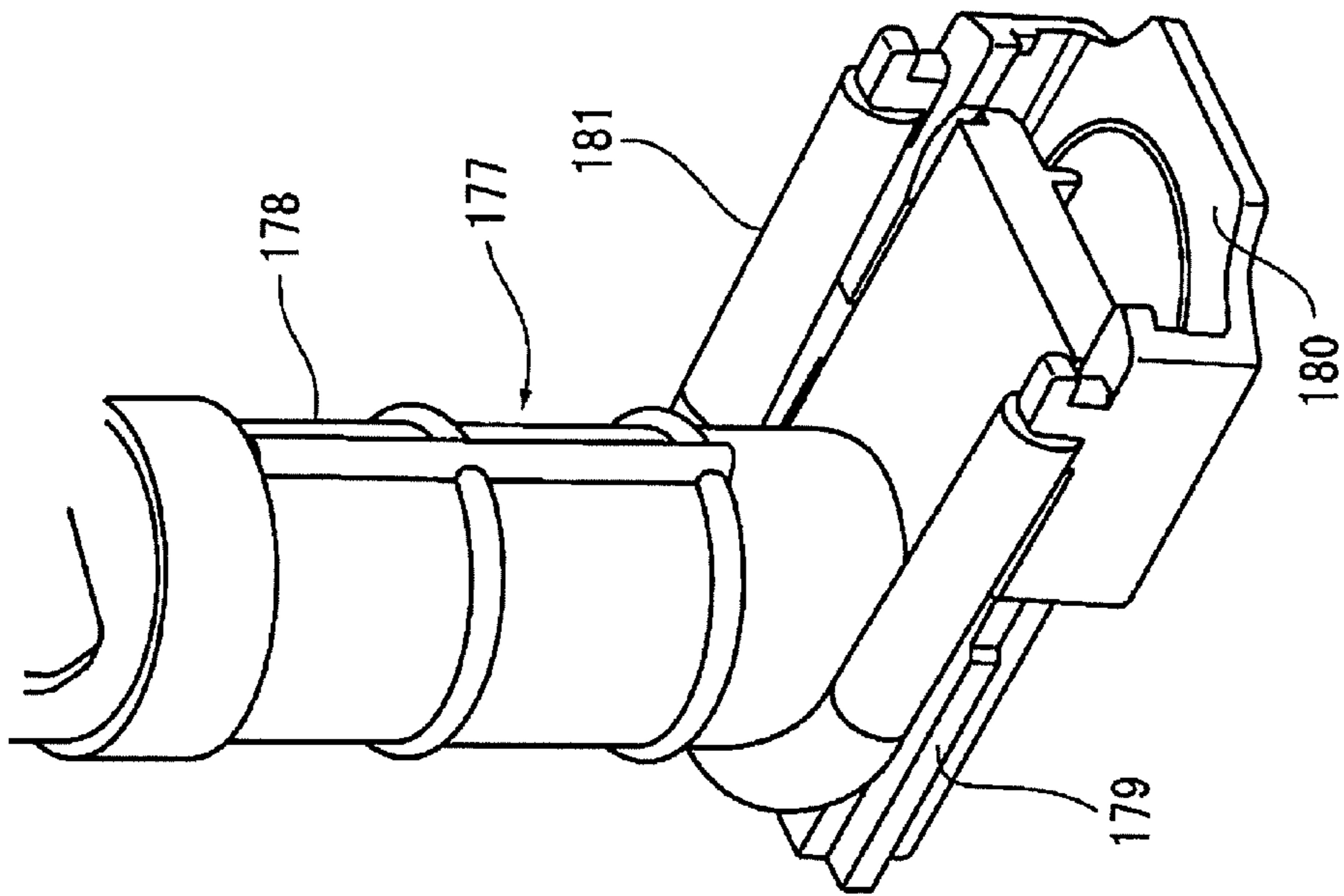
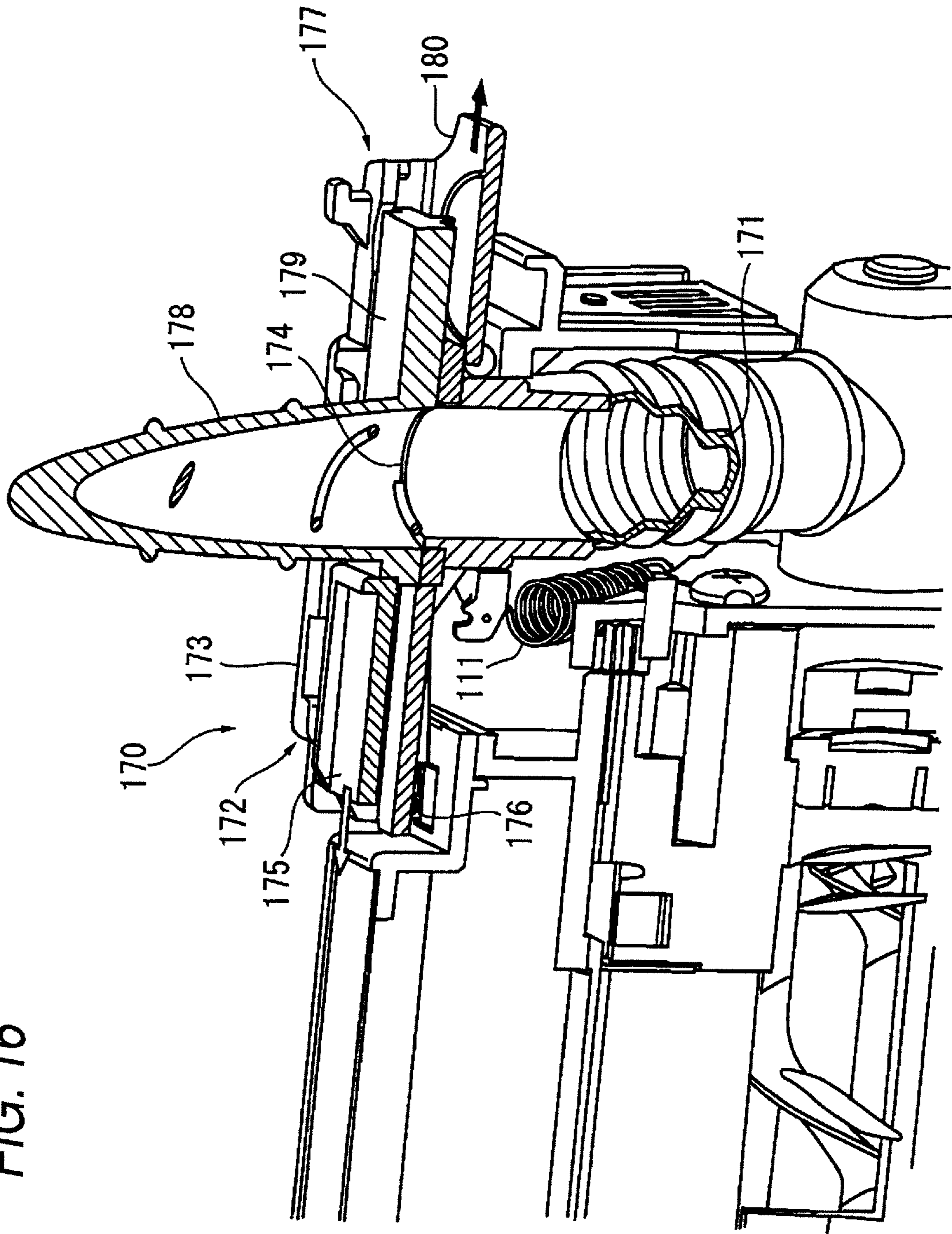

FIG. 16



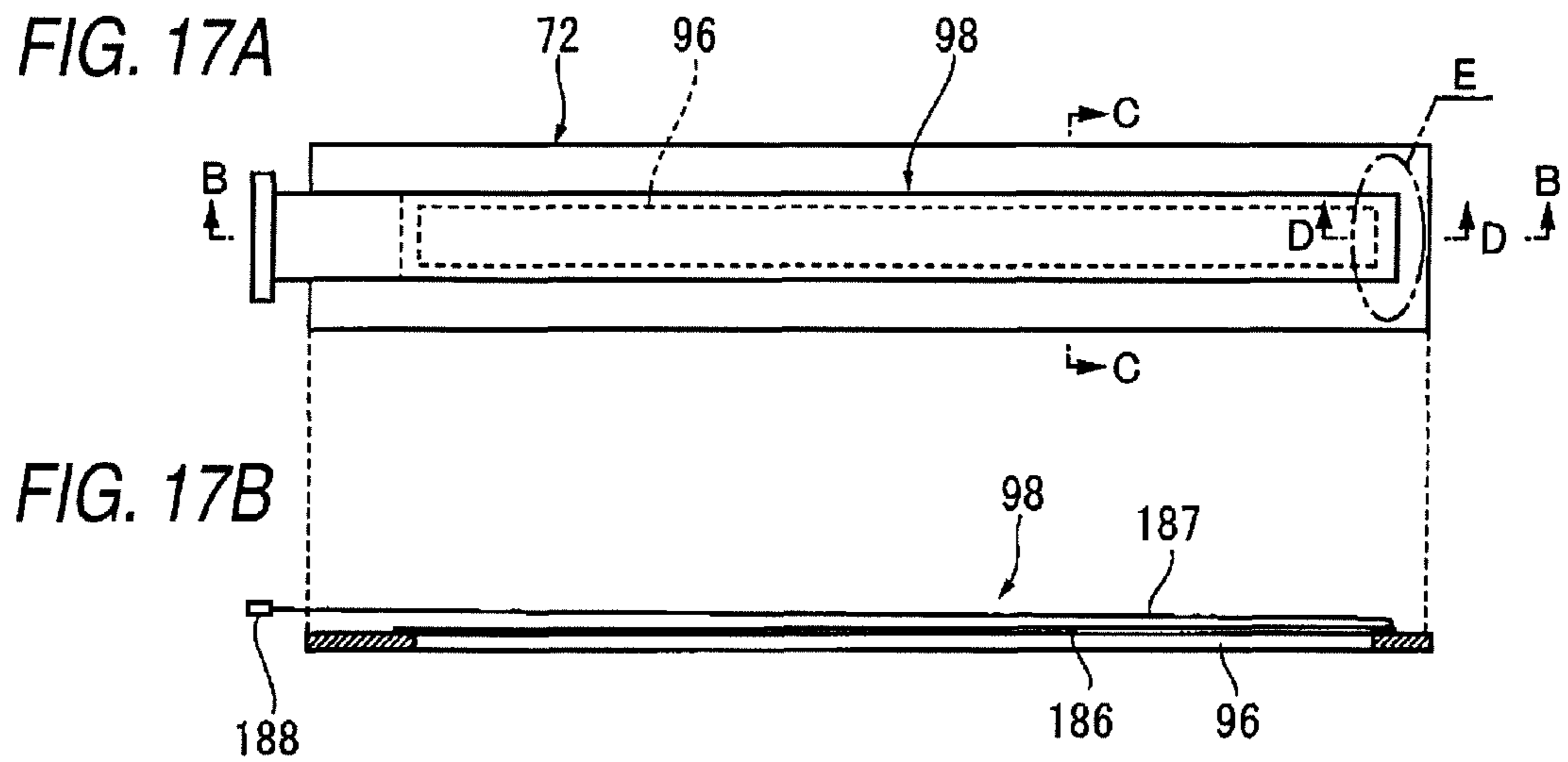

FIG. 17C

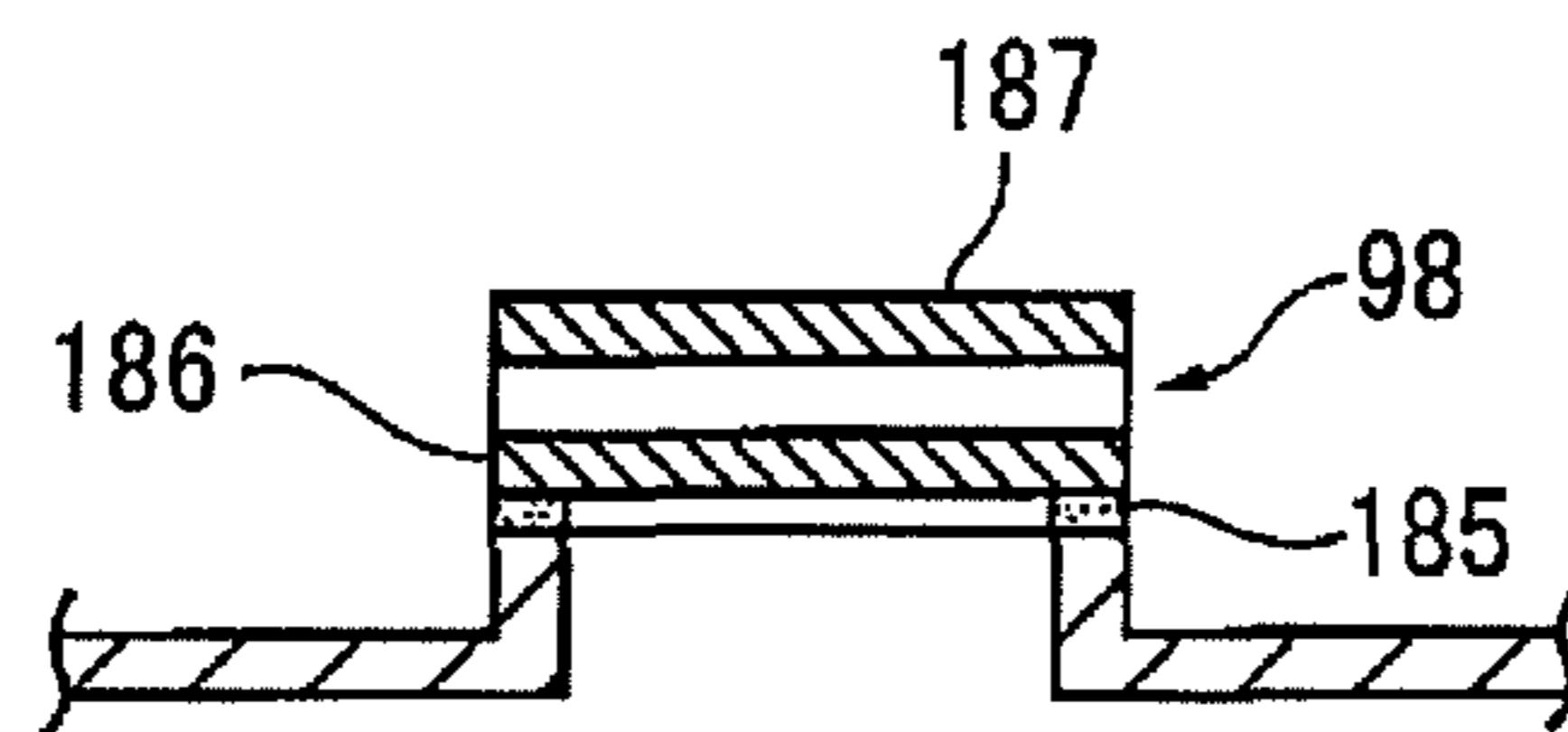

FIG. 17D

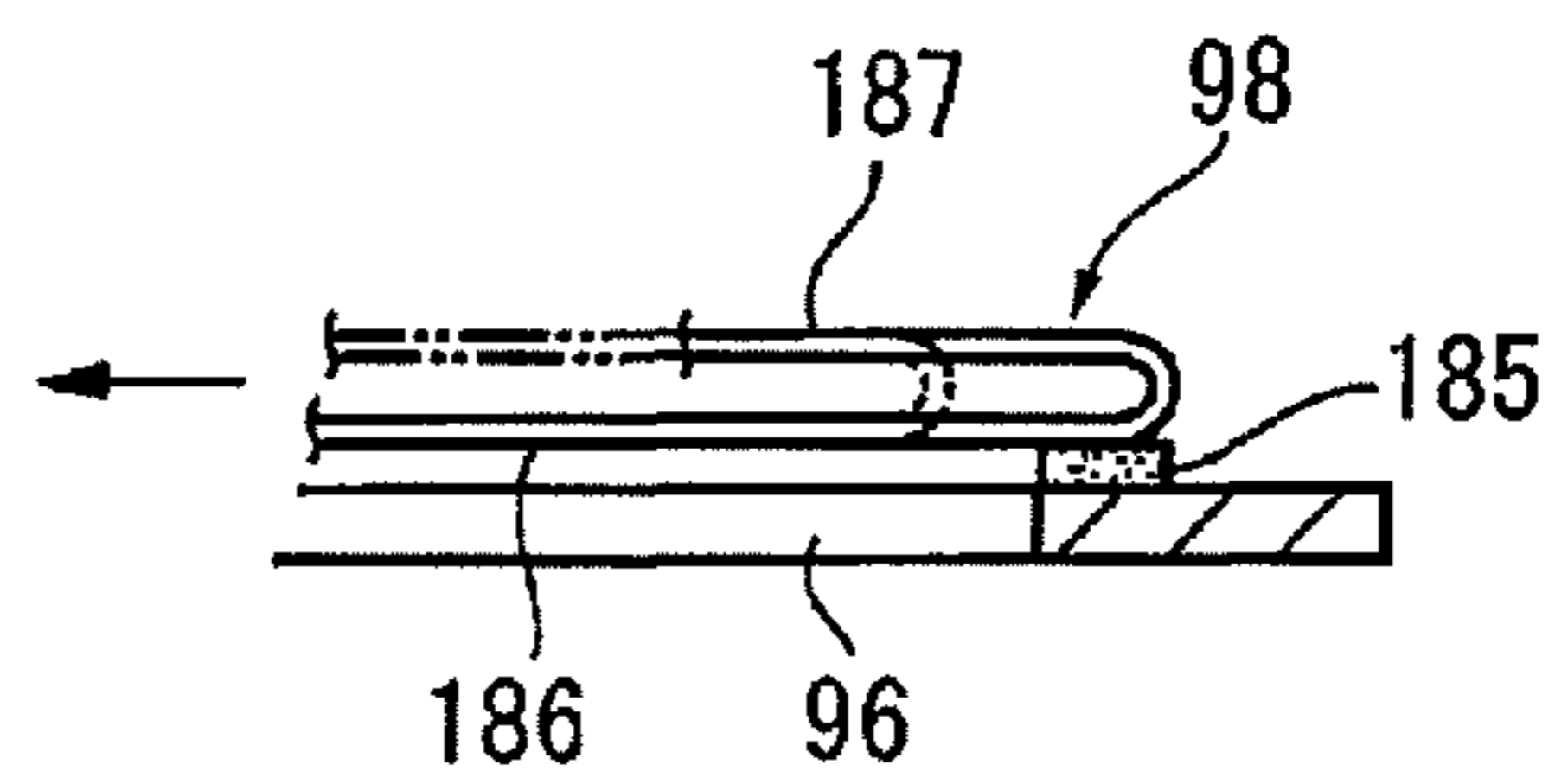
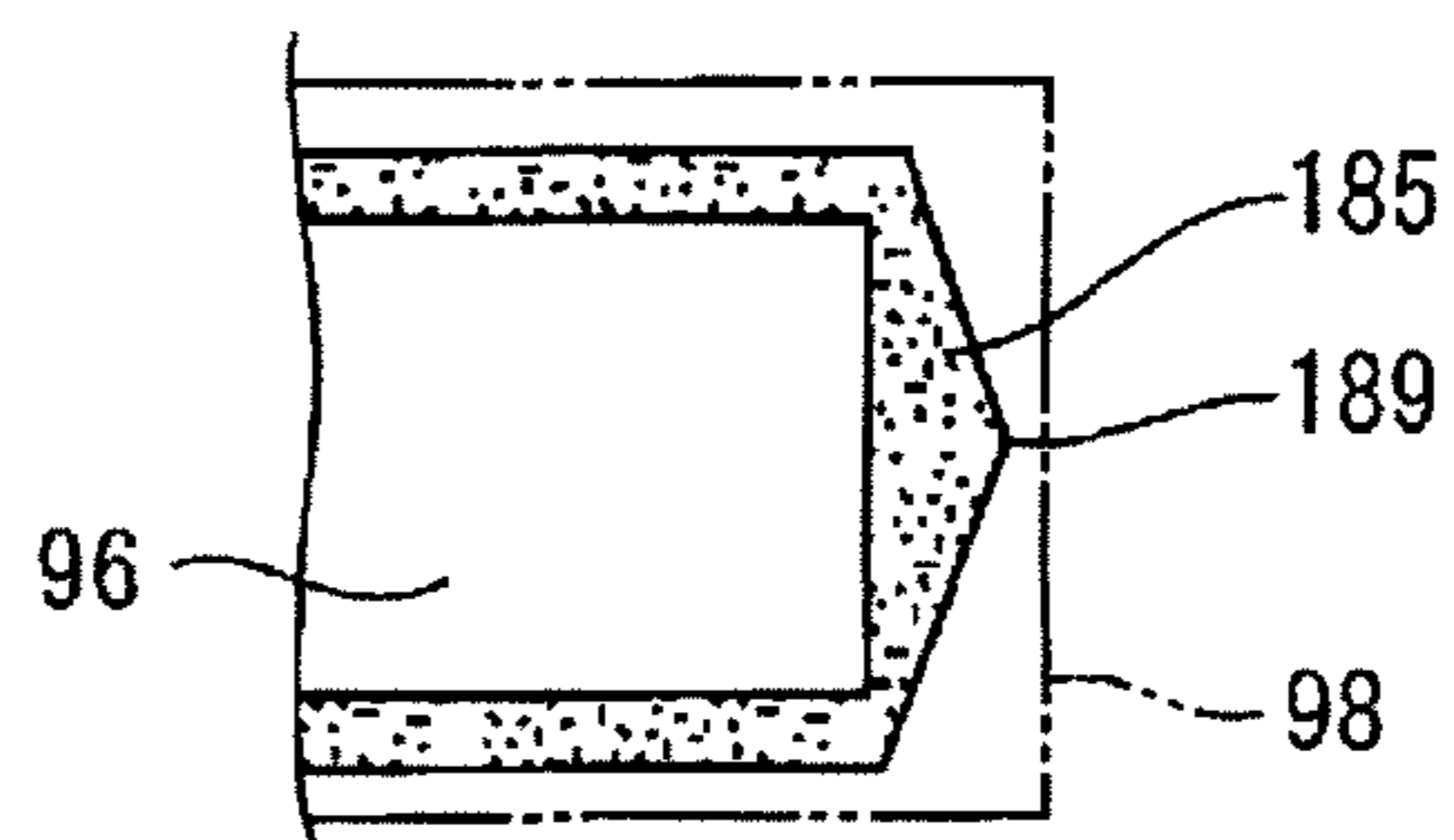

FIG. 17E



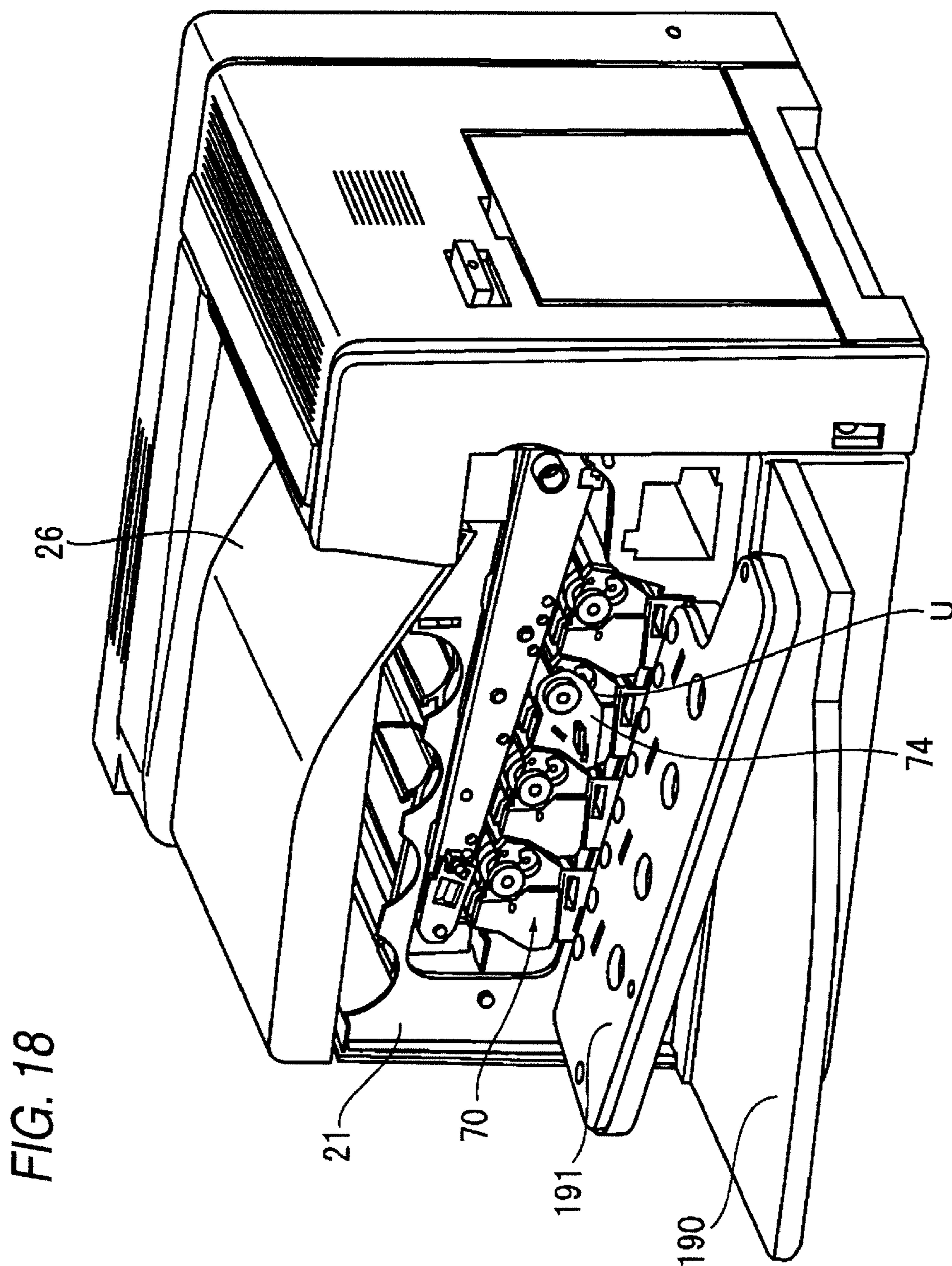
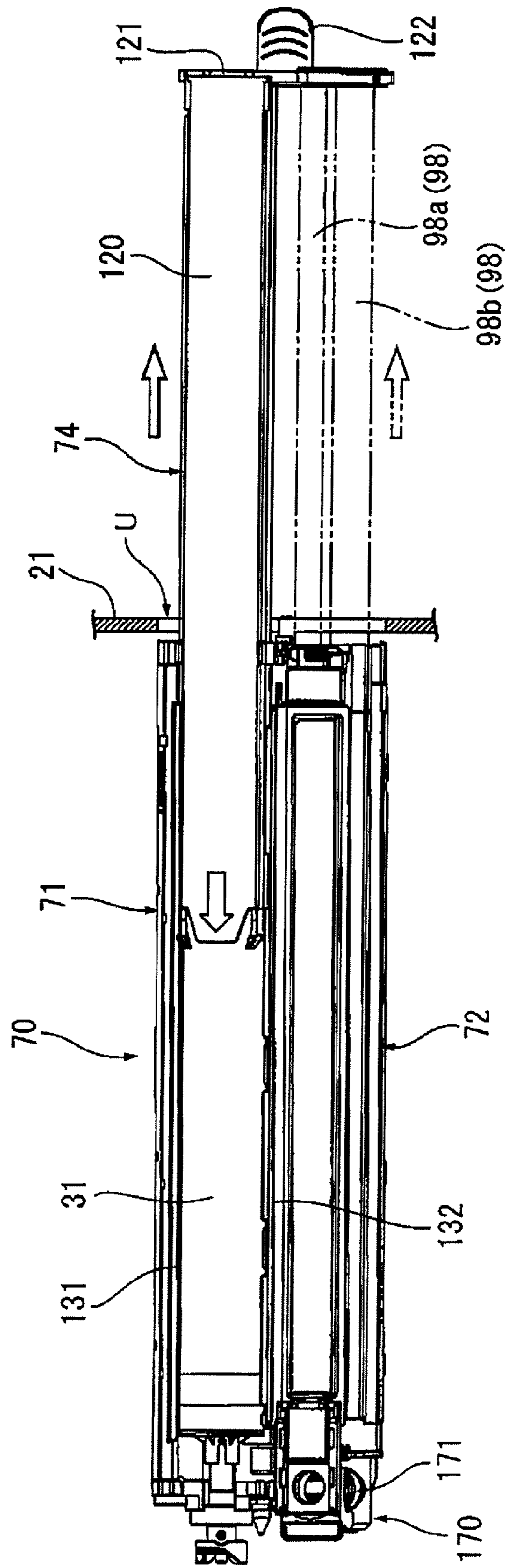
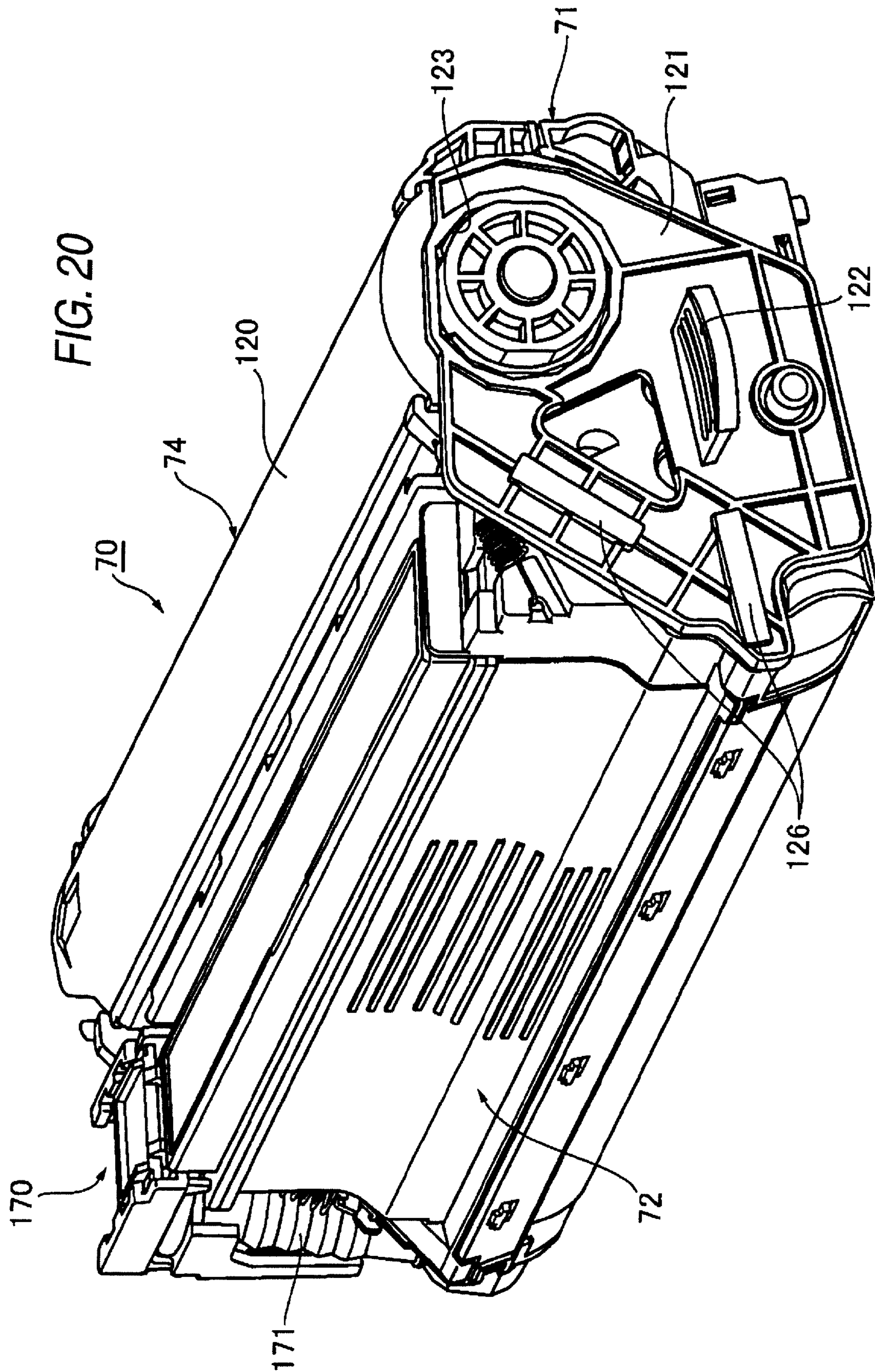

FIG. 19





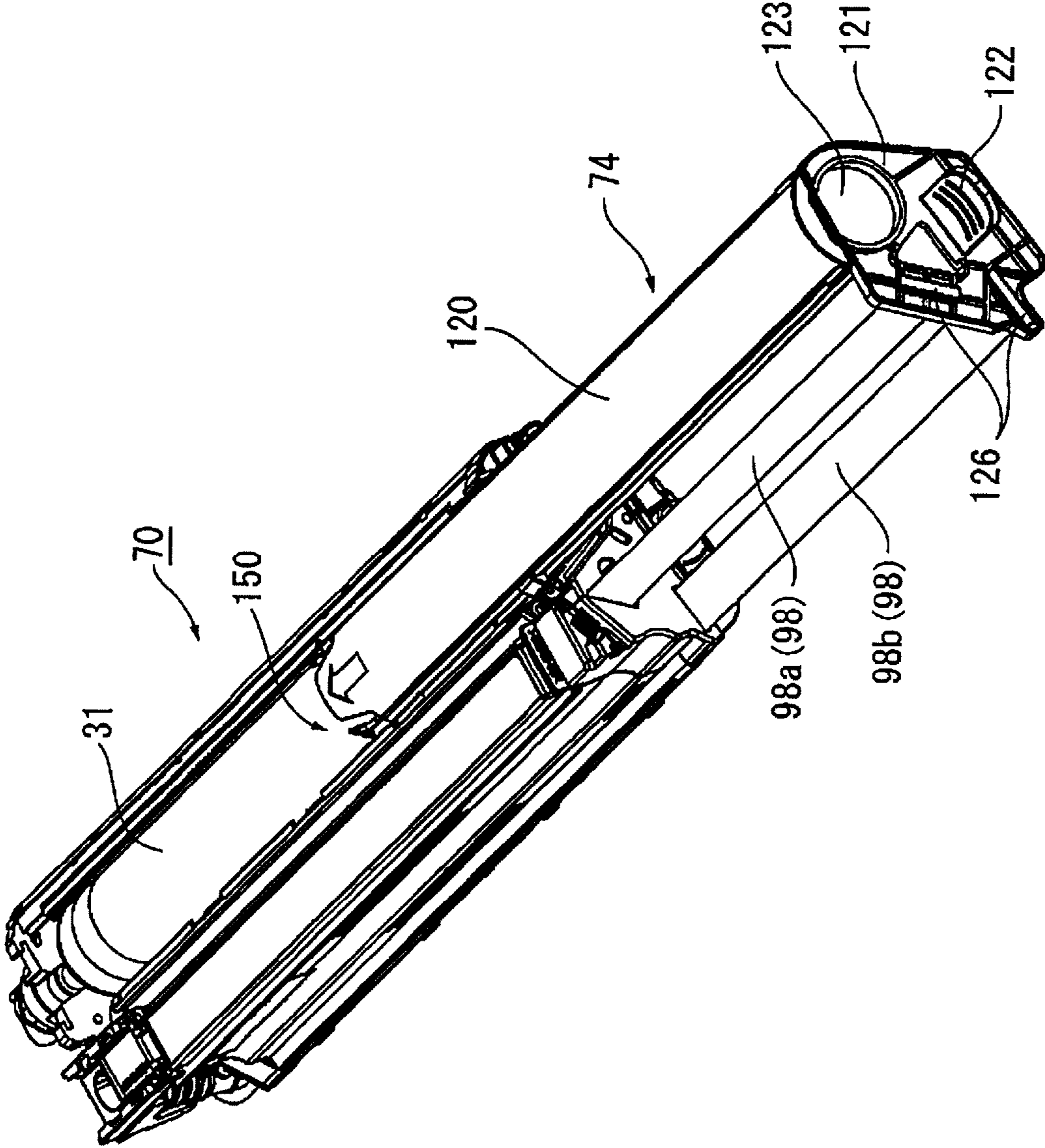

FIG. 21

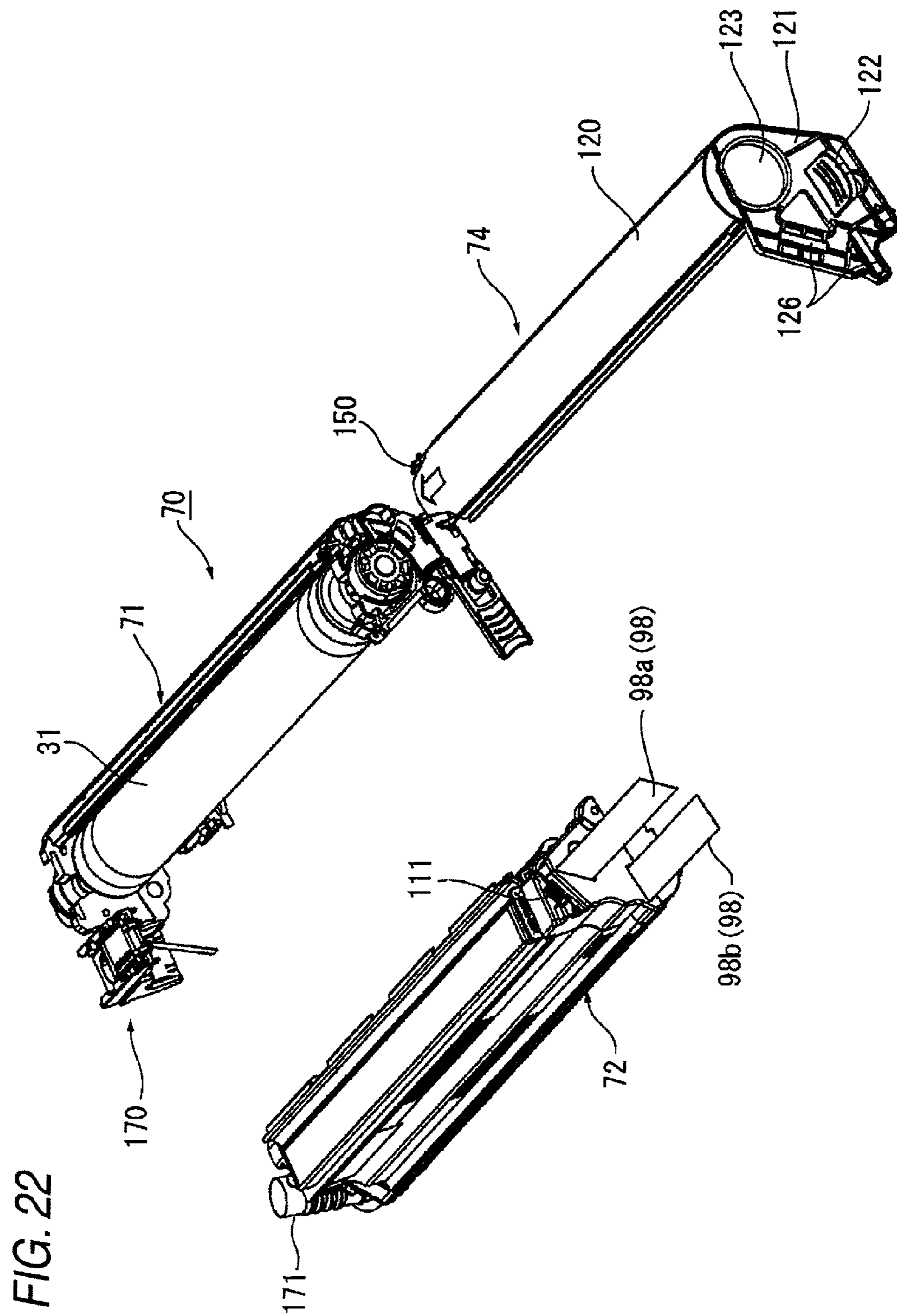

FIG. 23

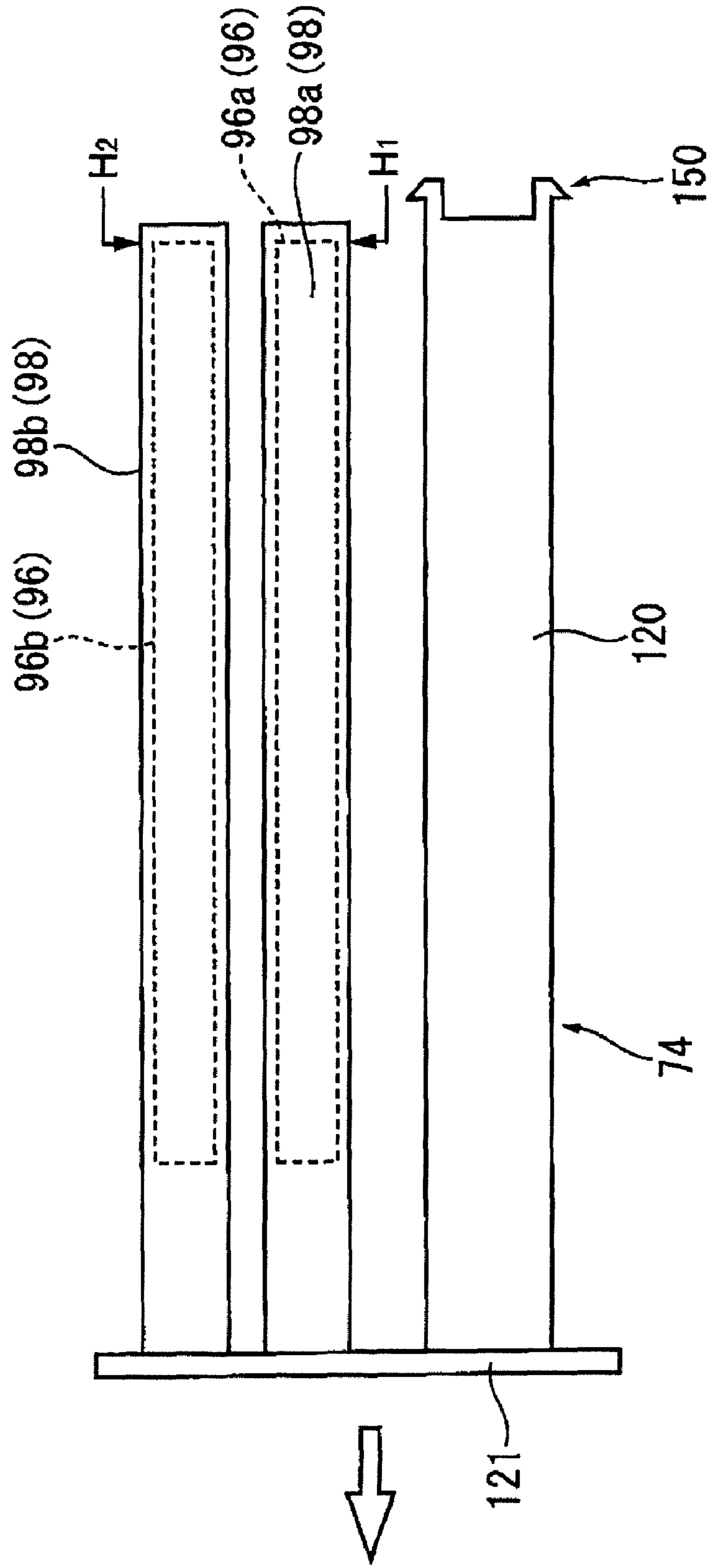

FIG. 24A

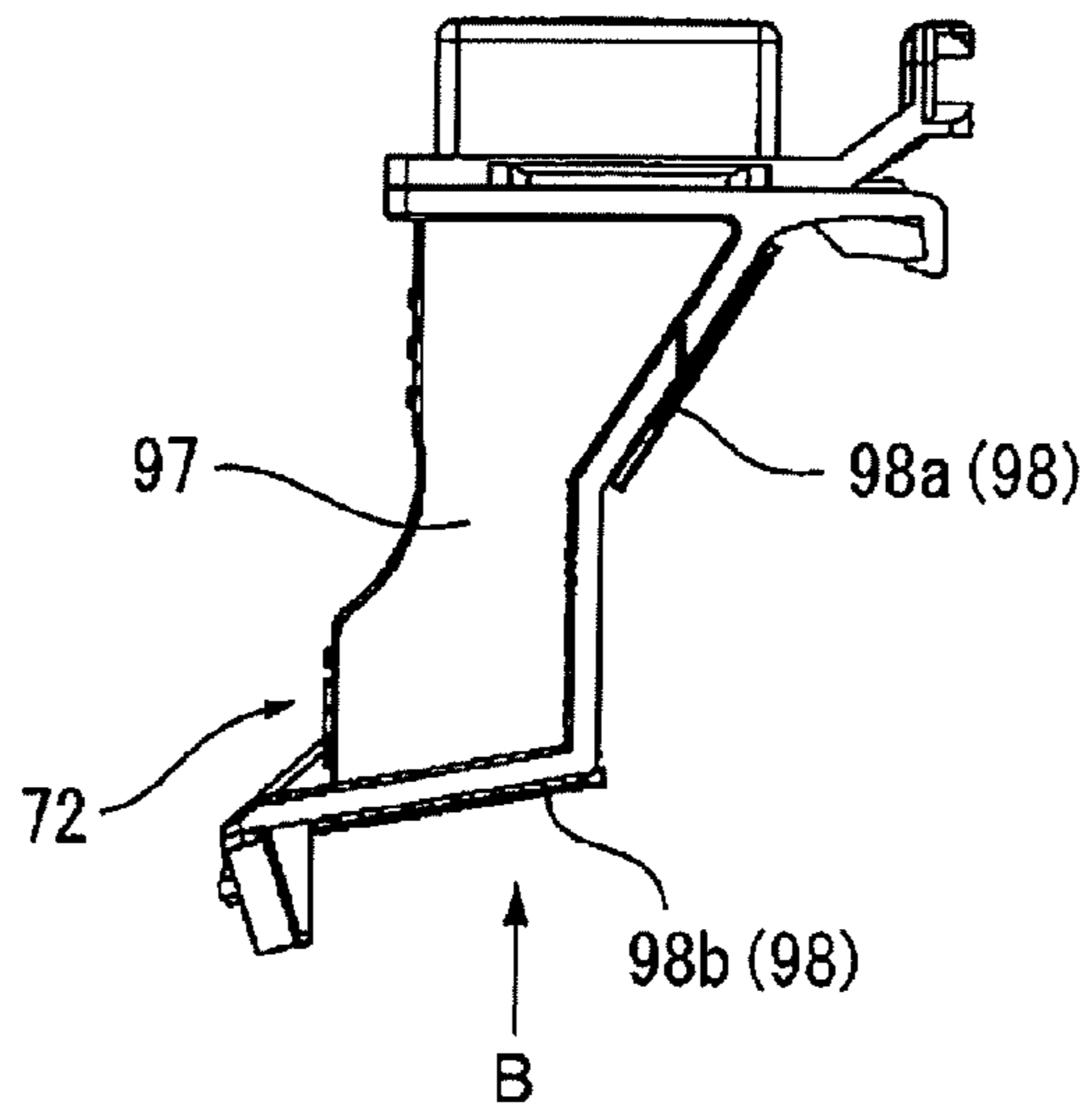

FIG. 24B

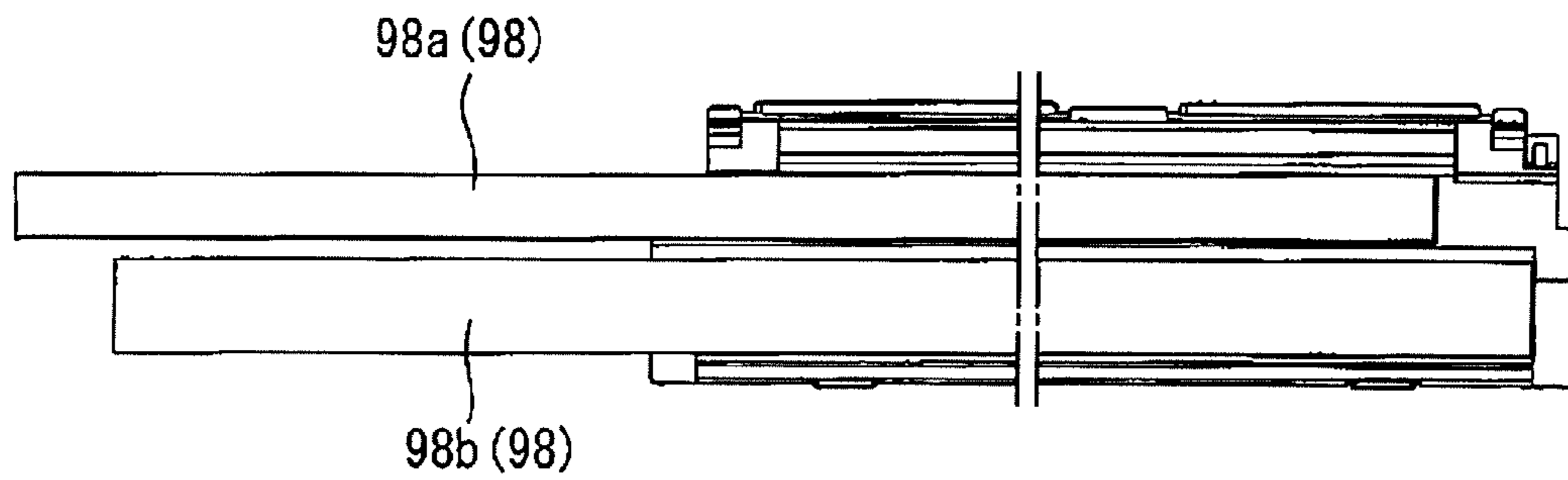

FIG. 24C

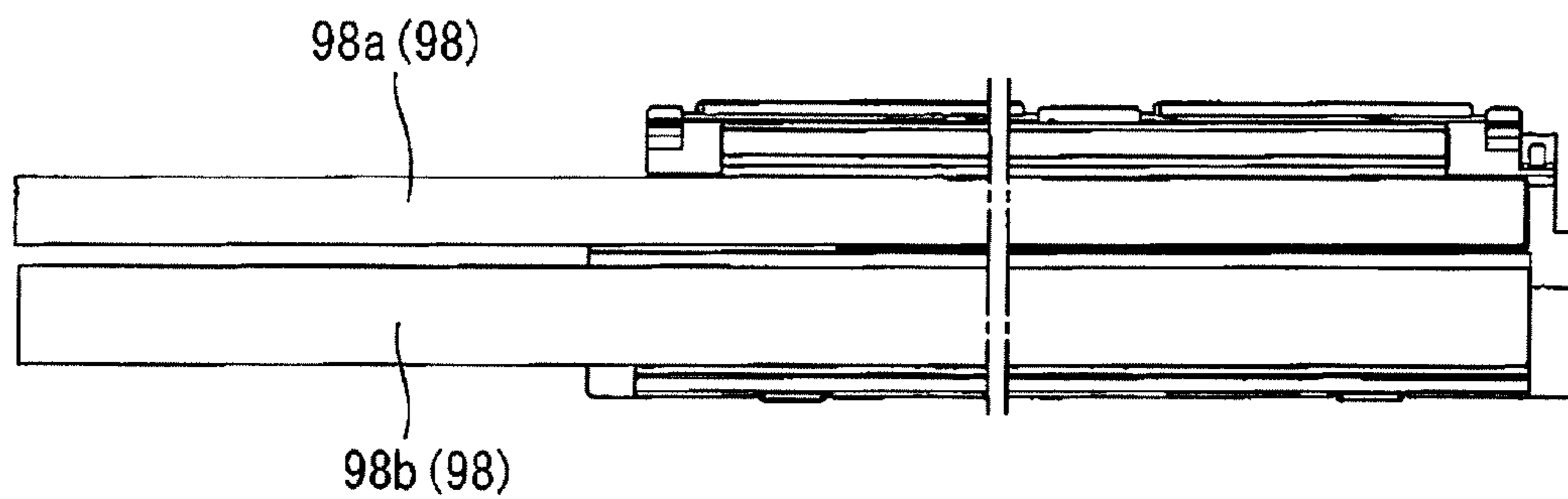

FIG. 25A

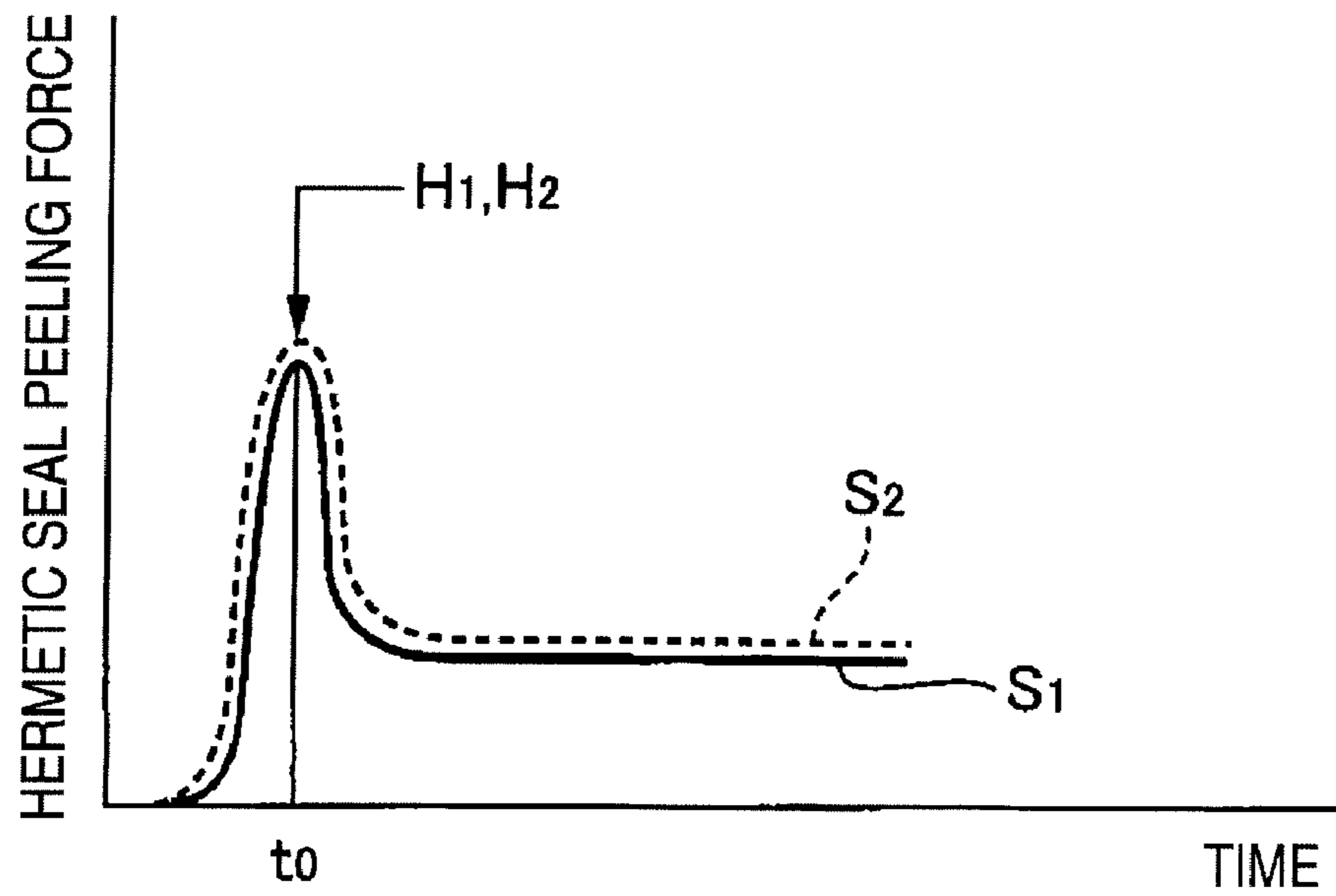

FIG. 25B

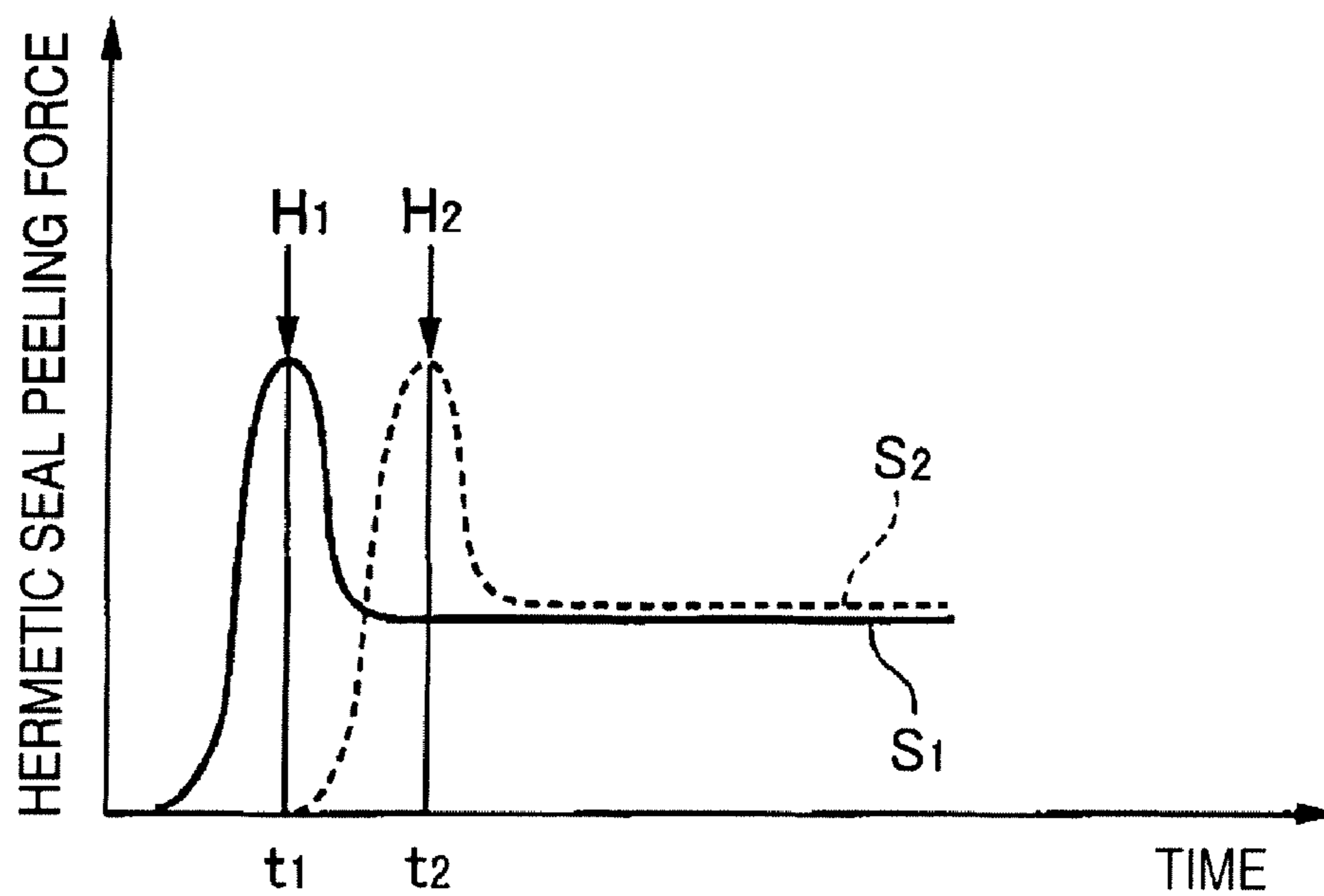

FIG. 26A

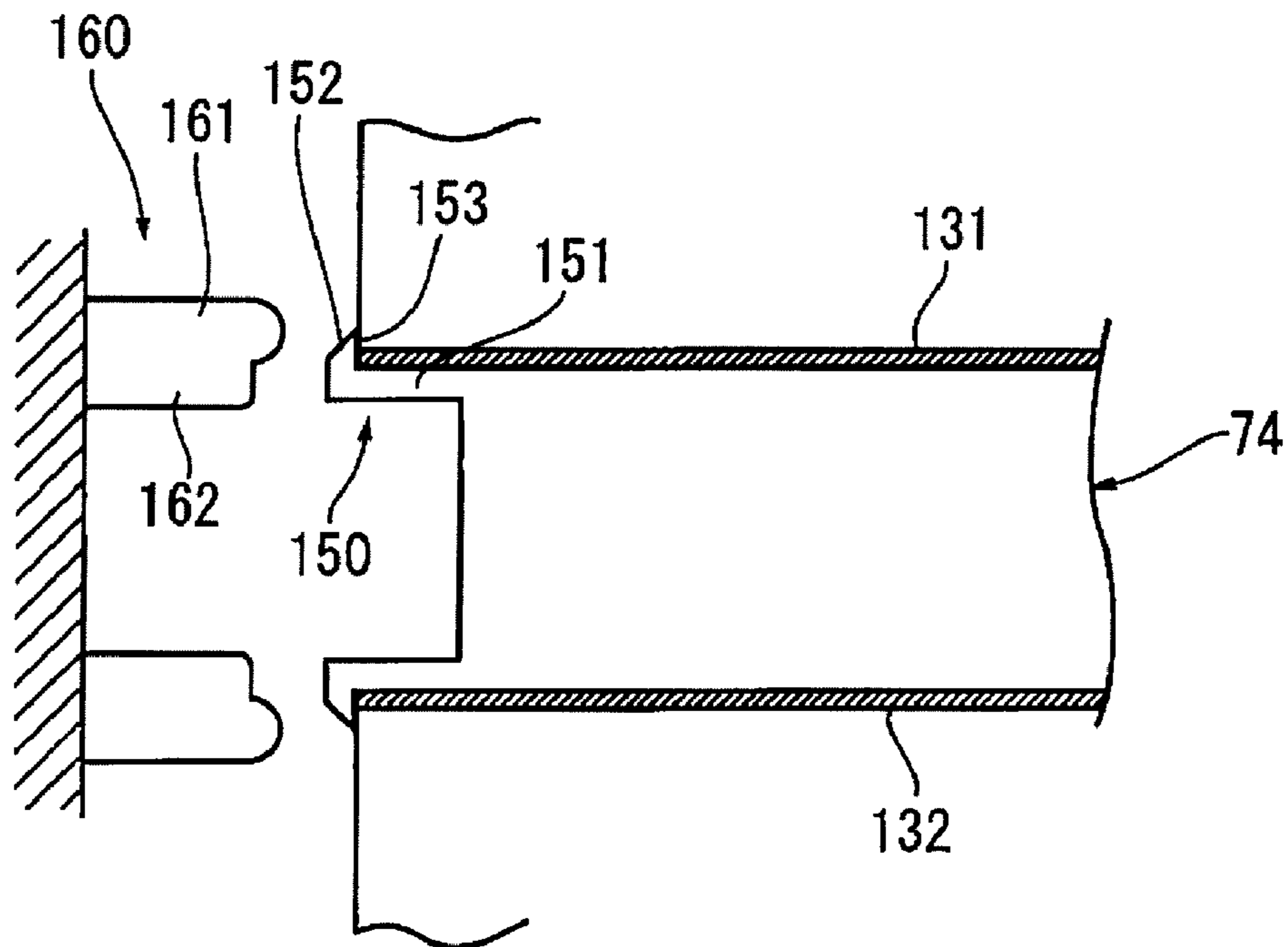
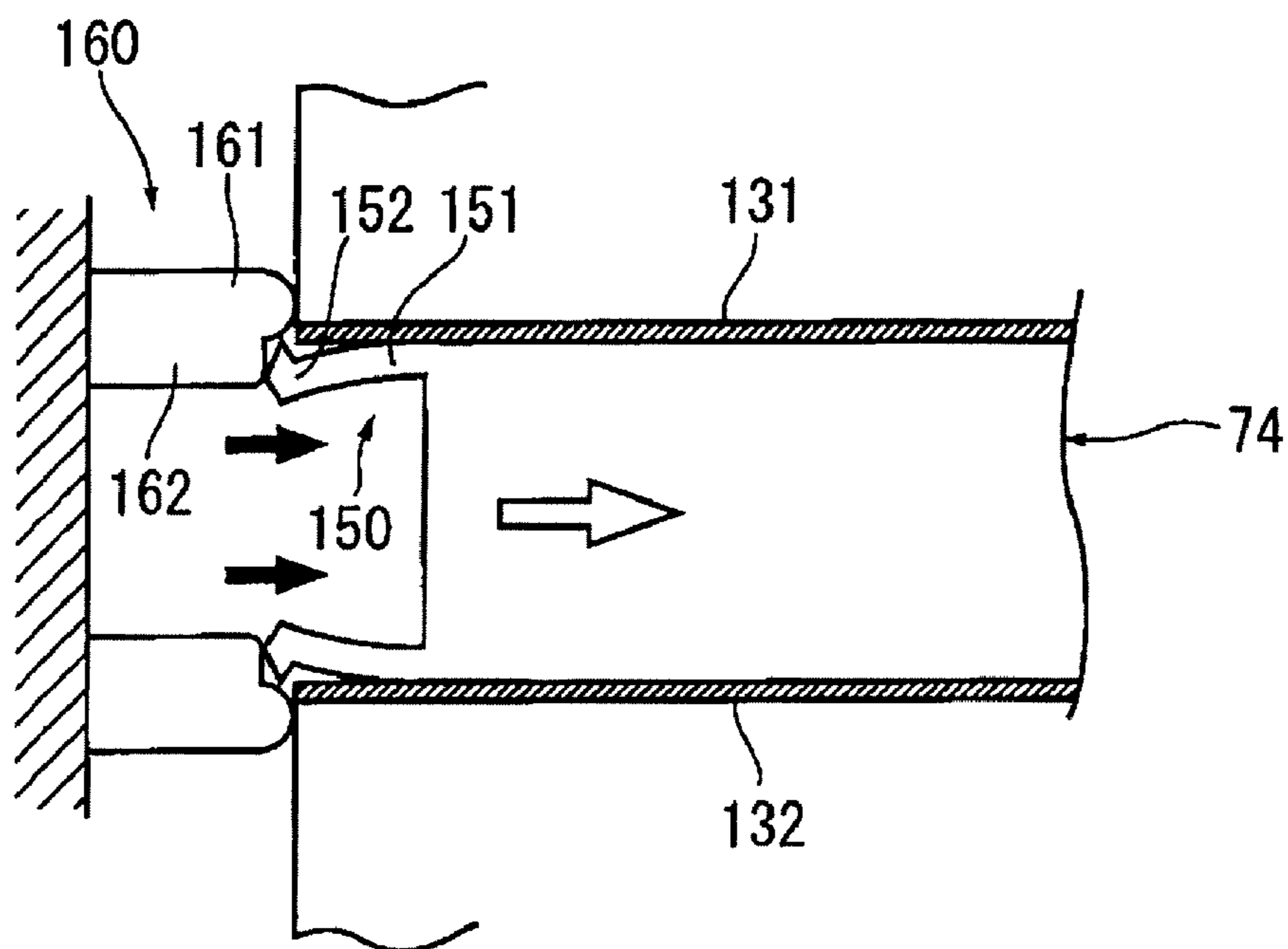

FIG. 26B



1

**IMAGE FORMING APPARATUS HAVING A
CONNECTING MECHANISM BETWEEN
PHOTORECEPTOR ASSEMBLY AND
DEVELOPING ASSEMBLY**

CROSS-REFERENCE TO RELATED
APPLICATIONS

This application is based on and claims priority under 35 USC 119 from Japanese Patent Application No. 2009-034200 filed on Feb. 17, 2009.

BACKGROUND

Technical Field

The present invention relates to an image forming assembly and an image forming apparatus using the same.

SUMMARY

According to an aspect of the invention, there is provided an image forming assembly, which is detachably mounted on a receiving section provided beforehand in a housing of an image forming apparatus and forms an image on a transfer medium, the image forming assembly including: a photoreceptor assembly that includes: a photoreceptor, and an accommodating container that accommodates at least the photoreceptor and holds the photoreceptor with a part of the photoreceptor being exposed; a developing assembly that includes: a developing member, and a developer container that accommodates at least the developer member and holds the developing member so as to position the developing member at a portion opposed to the photoreceptor; a connecting mechanism that connects the photoreceptor assembly to the developing assembly so that a distance between the photoreceptor and the developing member is changeable; a protection member that covers and protects the exposed portion of the photoreceptor; and guide members that are respectively provided on the accommodating container and the developer container, and that detachably guide the protection member with the protection member lying astride the two assemblies.

BRIEF DESCRIPTION OF THE DRAWINGS

Exemplary embodiment(s) of the present invention will be described in detail based on the following figures, wherein:

FIG. 1A is an explanatory view showing the outline of an exemplary embodiment of an image forming apparatus to which the present invention is applied; and FIG. 1B is a sectional view taken on line B-B of FIG. 1A;

FIG. 2A is an explanatory view showing a mounting state of the image forming assembly of the image forming apparatus shown in FIG. 2A; and FIG. 2B is an explanatory view showing an example of a constraint-releasing structure when the protection member shown in FIG. 1 is removed;

FIG. 3 is an explanatory view showing the overall configuration of the image forming apparatus being used in Exemplary Embodiment 1;

FIG. 4 is a perspective explanatory view showing an image forming assembly being used in Exemplary Embodiment 1;

FIG. 5 is an exploded perspective view showing the image forming assembly shown in FIG. 4;

FIGS. 6A and 6B are further exploded perspective explanatory views showing the photoreceptor assembly and the developing assembly shown in FIG. 5:

2

FIG. 7 is a perspective explanatory view showing a state in which a protection cover is removed from the image forming assembly shown in FIG. 4;

FIG. 8 is a view seen from arrow VIII of FIG. 7;

FIG. 9 is a sectional explanatory view taken on line IX-IX of FIG. 8;

FIG. 10 is a sectional explanatory view corresponding to FIG. 9 and showing the image forming assembly before the protection cover and hermetic seals are removed;

FIG. 11A is an explanatory view showing the relationship between the photoreceptor assembly and the developing assembly of the image forming assembly shown in FIG. 10; and FIG. 11B is a vertical sectional explanatory view of FIG. 11A;

FIG. 12 is a perspective explanatory view showing a mechanism for constraining the protection cover of the image forming assembly shown in FIG. 10;

FIG. 13 is a magnified plan explanatory view showing main sections shown in FIG. 12;

FIG. 14A is an explanatory view showing an example of the constraint-releasing mechanism of the protection cover; and FIG. 14B is an explanatory view showing the action of the constraint-releasing mechanism of the protection cover shown in FIG. 14A;

FIG. 15A is an explanatory view showing an example of a toner replenishing mechanism for the image forming assembly being used in Exemplary Embodiment 1; and FIG. 15B is an explanatory view showing the components of the toner replenishing mechanism on the side of a toner cartridge;

FIG. 16 is an explanatory view showing a state of the toner replenishing mechanism shown in FIGS. 15A and 15B when the image forming assembly being used in Exemplary Embodiment 1 is mounted;

FIG. 17A is an explanatory view showing the installation structure of the hermetic seal; FIG. 17B is a sectional explanatory view taken on line B-B of FIG. 17A; FIG. 17C is a sectional explanatory view taken on line C-C of FIG. 17A; FIG. 17D is a sectional explanatory view taken on line D-D of FIG. 17A; and FIG. 17E is a magnified explanatory view showing section E of FIG. 17A;

FIG. 18 is an explanatory view showing the process of mounting the image forming assembly on the housing of the image forming apparatus in Exemplary Embodiment 1;

FIG. 19 is an explanatory view showing a state in which the protection cover and the hermetic seals are removed from the image forming assembly shown in FIG. 18;

FIG. 20 is a perspective explanatory view showing an image forming assembly being used in Exemplary Embodiment 2;

FIG. 21 is a perspective explanatory view showing a state in which the protection cover is removed from the image forming assembly being used in Exemplary Embodiment 2;

FIG. 22 is an exploded perspective view showing the image forming assembly being used in Exemplary Embodiment 2;

FIG. 23 is an explanatory view showing the relationship between the protection cover and the hermetic seals being used in Exemplary Embodiment 2;

FIG. 24A is an explanatory view showing the installation state of the hermetic seals in the developing assembly; FIG. 24B is a view seen from arrow B of FIG. 24A; and FIG. 24C is a view seen from arrow B of FIG. 24A, showing a mode in which the installation positions of the hermetic seals are changed;

FIG. 25A is an explanatory view showing an example of the change in force for peeling multiple hermetic seals with respect to time; and FIG. 25B is an explanatory view showing

another example of the change in force for peeling multiple hermetic seals with respect to time; and

FIG. 26A is an explanatory view showing an example of the constraint-releasing mechanism of the protection cover being used in Exemplary Embodiment 2; and FIG. 26B is an explanatory view showing the action of the constraint-releasing mechanism of the protection cover shown in FIG. 26A, wherein

1 denotes Image forming assembly, 2 denotes Photoreceptor assembly, 3 denotes Accommodating container, 4 denotes Photoreceptor, 5 denotes Charger, 6 denotes Cleaner, 7 denotes Neutralizing unit, 10 denotes Developing assembly, 11 denotes Developer container, 11a denotes Developer accommodating chamber, 11b denotes Initial developer storing chamber, 12 denotes Developing member, 13 denotes Developer stirring member, 14 denotes Connecting mechanism, 15 denotes Protection member, 16 (16a and 16b) denote Guide members, 17 denotes Constraining mechanism, 18 (18a and 18b) denotes Hermetic sealing members, 19 denotes Constraint-releasing mechanism, W denotes Housing of image forming apparatus, and U denotes Receiving section of assembly

DETAILED DESCRIPTION

General Description of Exemplary Embodiment

First, a general description of an exemplary embodiment of an image forming apparatus to which the present invention is applied will be given below referring to FIGS. 1 and 2.

In this exemplary embodiment, the image forming apparatus includes, as shown in FIG. 1A, an assembly receiving section U provided beforehand in the housing W of the image forming apparatus and an image forming assembly 1 detachably mounted on this assembly receiving section U.

As shown in FIG. 1B, the image forming assembly 1 being used in the exemplary embodiment includes a photoreceptor assembly 2 in which at least a photoreceptor 4 is accommodated in an accommodating container 3 and the photoreceptor 4 is held in the accommodating container 3 while part thereof is exposed; a developing assembly 10 in which at least a developing member 12 is accommodated in a developer container 11 and the developing member 12 is held in the developer container 11 so that the developing member 12 is positioned at a portion opposed to the photoreceptor 4 of the photoreceptor assembly 2; a connecting mechanism 14 for connecting the photoreceptor assembly 2 to the developing assembly 10 so that the distance between the photoreceptor 4 of the photoreceptor assembly 2 and the developing member 12 of the developing assembly 10 is changeable; a protection member 15 for protecting the exposed portion of the photoreceptor 4 of the photoreceptor assembly 2 so as to cover the exposed portion; and guide members 16 (more specifically, 16a and 16b) respectively provided on the accommodating container 3 of the photoreceptor assembly 2 and the developer container 11 of the developing assembly 10, for detachably guiding the protection member 15 while the protection member 15 is lying astride the two assemblies 2 and 10.

With this kind of technical structure, the image forming assembly 1 is used to form images on transfer media. The transfer media herein include not only recording media but also, for example, intermediate transfer members for intermediately transferring and holding images before the images are transferred to recording media.

The image forming assembly 1 is configured so that the photoreceptor assembly 2 and the developing assembly 10 are movably connected to each other via the connecting mechanism 14

In addition, the photoreceptor assembly 2 includes not only a mode in which the photoreceptor 4 is accommodated in the accommodating container 3 as a matter of course, but also a mode in which, in addition to the photoreceptor 4, all or some of a charger 5 for charging the photoreceptor 4, a cleaner 6 for cleaning the surface of the photoreceptor 4 and a neutralizing unit 7 for removing the charge remaining on the photoreceptor 4 are accommodated.

Furthermore, the developing assembly 10 includes not only a mode in which the developing member 12, such as a developer holding member, is accommodated in the developer container 11 as a matter of course, but also a mode in which, in addition to the developing member 12, other functional members, such as a developer stirring member 13 for stirring and conveying developer inside the developer container 11 and a developer layer thickness restricting member (not shown) for restricting the thickness of the developer layer held in the developing member 12.

Moreover, the connecting mechanism 14 should only be a mechanism for connecting the two assemblies 2 and 10 so that the distance between the photoreceptor 4 and the developing member 12 is changeable. A typical example of the mechanism may include a mechanism for rockably supporting the two assemblies.

Besides, it is preferable that the protection member 15 should cover the exposed portion of the photoreceptor 4 in a non-contact state. However, if the protection member 15 is made of a soft material so as not to damage the photoreceptor 4, the protection member 15 may be disposed so as to make contact with the exposed portion of the photoreceptor 4.

Still further, the guide members 16 (more specifically, 16a and 16b) should only be provided on the accommodating container 3 of the photoreceptor assembly 2 and the developer container 11 of the developing assembly 10, respectively, so as to detachably guide the protection member 15.

In addition, a preferable example of the guide members 16 for guiding the protection member 15 may include guide members provided on the accommodating container 3 of the photoreceptor assembly 2 and the developer container 11 of the developing assembly 10, extending in the attaching/detaching direction of the image forming assembly 1 and slidably guiding the protection member 15.

Furthermore, from the viewpoint of preventing the photoreceptor 4 and peripheral components around the protection member 15 from being damaged, it is preferable that the protection member 15 should be extractably moved in one direction of the guide members 16.

Moreover, from the viewpoint of avoiding a situation in which the protection member 15 is moved unnecessarily when the image forming assembly 1 is stored or conveyed, it is preferable that the image forming assembly includes a constraining mechanism 17 for constraining the movement of the protection member 15 with respect to the guide members 16.

Besides, from the viewpoint of maintaining the positional relationship between the photoreceptor 4 and the developing member 12 constant when the image forming assembly 1 is mounted, it is preferable that the image forming assembly includes a position adjusting member (not shown) for maintaining the positional relationship between the developing member 12 of the developing assembly 10 and the photoreceptor 4 of the photoreceptor assembly 2 constant.

Still further, even in a mode in which the developing member 12 is equipped with the position adjusting member, since the protection member 15 is provided so as to be lying astride the accommodating container 3 of the photoreceptor assembly 2 and the developer container 11 of the developing assembly

bly 10, the positional relationship between the two assemblies 2 and 10 at the time when the image forming assembly 1 is not mounted is restricted by the protection member 15. Hence, there is no fear that the position adjusting member may collide with the photoreceptor 4 unnecessarily.

What's more, from the viewpoint of effectively avoiding the developing member 12 of the developing assembly 10 and the photoreceptor 4 of the photoreceptor assembly 2 from being damaged, it is preferable that the distance between the developing member 12 of the developing assembly 10 and the photoreceptor 4 of the photoreceptor assembly 2 should be maintained in a direction that the two are away from each other when the protection member 15 is in a constrained state.

In addition, as a typical mode of the developing assembly 10, the developing assembly 10 has a developer accommodating chamber 11a for accommodating developer inside the developer container and an initial developer storing chamber 11b, adjacent to the developer accommodating chamber 11a via opening sections, for storing initial developer before use. When the developing assembly 10 is not used, the opening sections between the initial developer storing chamber 11b and the developer accommodating chamber 11a is hermetically sealed with hermetic sealing members 18 (more specifically, 18a and 18b).

In this kind of mode, the work for removing the hermetic sealing members 18 (18a and 18b) may be performed independently of the work for removing the protection member 15. However, from the viewpoint of simplifying the work for removing the hermetic sealing members 18, a mode is preferably used in which the hermetic sealing members 18 are fixed to the protection member 15 as shown in FIG. 2A so as to be movable together with the protection member 15.

Among these modes, in the mode in which the protection member 15 is slidably guided along the guide members 16, the movement loci of the hermetic sealing members 18 are stabilized. Hence, this mode is preferable in that it is possible to avoid situations in which the hermetic sealing members 18 are twisted or torn off and the operation force during the movement increases.

Furthermore, the hermetic sealing members 18 should only be movable together with the protection member 15. When the operation for removing the protection member 15 is completed, it may be possible that the hermetic sealing state by the hermetic sealing members 18 is not released entirely or partly. The hermetic sealing state by the hermetic sealing members 18 should only be released by further moving the protection member 15 outwards.

However, a preferable mode of the hermetic sealing members 18 may include a mode in which, when the protection member 15 is removed from the guide members 16, the opening sections between the initial developer storing chamber 11b and the developer accommodating chamber 11a are opened and the hermetic sealing members 18 are moved together with the protection member 15 so that the initial developer is supplied into the developer accommodating chamber 11a.

Moreover, in a mode including a constraining mechanism 17 capable of constraining the movement of the protection member 15 with respect to the guide members 16 and capable of releasing the constrained state of the protection member 15, from the viewpoint of decreasing the operation force for releasing the hermetic sealing state by the hermetic sealing members 18, a mode is preferable in which, when the constrained state of the protection member 15 by the constraining mechanism 17 is released, the protection member 15 starts moving along the guide members 16, whereby the hermetic sealing state by the hermetic sealing members 18 is released.

The releasing is herein not limited to a case in which the hermetic sealing state is entirely released but includes a case in which the hermetic sealing state is partly released.

Besides, from the viewpoint of improving the efficiency of supplying the initial developer, a mode is preferable in which multiple hermetic sealing members 18 (for example, 18a and 18b) are provided as shown in FIG. 1B.

As a preferable mode having multiple hermetic sealing members 18, from the viewpoint of decreasing the operation force required to release the hermetic sealing by the hermetic sealing members 18 (18a and 18b), a mode may be included in which the releasing operations of the hermetic sealing states of the multiple hermetic sealing members 18 (18a and 18b) are started at different times in accordance with the removal of the protection member 15.

In addition, as a preferable mode of this kind of image forming apparatus, for example, as shown in FIGS. 2A and 2B, as the mode in which the image forming assembly 1 includes the constraining mechanism 17 for constraining the movement of the protection member 15 with respect to the guide members 16, a mode may be included in which the housing W is provided with a constraint-releasing mechanism 19 capable of releasing the constrained state of the protection member 15 by the constraining mechanism 17 when the image forming assembly 1 is mounted on the receiving section U.

An example of the constraining mechanism 17 may herein include a mechanism in which the movement of the protection member 15 is constrained by a pair of constraining pieces 17a that are elastically deformable. As the constraint-releasing mechanism 19, for example, as shown in FIG. 2B, the mechanism should only have a configuration in which the constraining pieces 17a are elastically deformed when the protruding pieces 19a protruding toward the constraining pieces 17a of the constraining mechanism 17 make contact with the constraining pieces 17a, thereby releasing the constrained state of the protection member 15.

Furthermore, in a mode in which the housing W has a door (not shown) that is opened and closed when the image forming assembly 1 is mounted on and dismantled from the receiving section U, from the viewpoint of avoiding forgetting to remove the protection member 15, it is preferable that the protection member 15 has a mode in which the protection member 15 is removable from the image forming assembly 1 when the image forming assembly 1 is mounted on the receiving section U of the housing W, and the door of the housing W is prevented from being closed in a state that the protection member 15 is not removed from the image forming assembly 1.

The present invention will be described below in greater detail on the basis of exemplary embodiments shown in the accompanying drawings.

Exemplary Embodiment 1

Overall Configuration of Image Forming Apparatus

FIG. 3 shows an overall configuration of Exemplary Embodiment 1 of an image forming apparatus to which the present invention is applied.

In FIG. 3, the image forming apparatus has image forming sections 22 (more specifically, 22a to 22d) for four colors (black, yellow, magenta and cyan in this exemplary embodiment) inside the housing 21 (hereafter referred to as an apparatus housing) thereof, the image forming sections being arranged in a lateral direction and inclined obliquely upward. Above the image forming sections 22, an intermediate transfer belt 23 that is circulated and moved in the arrangement direction of the image forming sections 22 is disposed. On the other hand, a recording media supplying device 24 for accom-

modating recording media so as to be able to supply the recording media is disposed in the lower section of the apparatus housing 21, and a discharged recording media receiver 26 for accommodating discharged recording media on which images are formed is provided in the upper section of the apparatus housing 21. The recording media from the recording media supplying device 24 are discharged to the discharged recording media receiver 26 via a recording media conveying path 25 extending in the nearly vertical direction.

In the exemplary embodiment, the image forming sections 22 (22a to 22d) are used to form toner images having the colors of black, yellow, magenta and cyan (the arrangement of the colors is not necessarily limited to this order), for example, in the order from the upstream side in the circulation direction of the intermediate transfer belt 23 as shown in FIG. 3. The image forming section includes, for example, a photoreceptor 31 formed into a drum shape; a charger 32 for charging this photoreceptor 31 beforehand; an exposing unit 33 for writing electrostatic latent images on the photoreceptor 31 charged by the charger 32; a developing unit 34 for visualizing the electrostatic latent image on the photoreceptor 31 with toner of each color; and a cleaner 35 for removing the toner remaining on the photoreceptor 31.

The exposing unit 33 is commonly used for each of the image forming sections 22. The light from a light source, such as a semiconductor laser (not shown) of each color component, inside an exposure container 331 is used for deflection scanning by virtue of a deflecting mirror 332 so that a light image is guided to an exposure position on the corresponding photoreceptor 31 via an imaging lens and a mirror (these are not shown).

In the exemplary embodiment, a neutralizing unit 36 (see FIGS. 9 and 10) for removing the charge remaining on the photoreceptor 31 is provided on the upstream side of the cleaner 35 in the rotation direction of the photoreceptor 31.

Furthermore, the intermediate transfer belt 23 is stretched around tension rolls 231 to 234 and circulates and moves by using the tension roll 231 as a driving roll, for example. A primary transfer unit 51 (for example, a primary transfer roll) is disposed on the rear face of the intermediate transfer belt 23 corresponding to each of the photoreceptors 31. The toner image on the photoreceptor 31 is electrostatically transferred to the intermediate transfer belt 23 by applying a voltage having a polarity opposed to that of the charge of the toner to this primary transfer unit 51.

Moreover, a secondary transfer unit 52 (for example, a secondary transfer roll) is disposed at a portion corresponding to the tension roll 234 on the downstream side of the image forming section 22d positioned on the extreme downstream side in the movement direction of the intermediate transfer belt 23, whereby secondary transfer (collective transfer) for the primary transfer images formed on the intermediate transfer belt 23 is performed on recording media.

Besides, an intermediate cleaner 53 for removing the toner remaining on the intermediate transfer belt 23 is provided at a portion corresponding to the tension roll 231 on the downstream side of the secondary transfer portion of the intermediate transfer belt 23.

A belt made of a resin, such as polyimide, polycarbonate, polyester or polypropylene, or a rubber, one of various kinds of rubbers, containing an appropriate amount of an antistatic agent, such as carbon black, so as to have a volume resistivity of 10^6 to 10^{14} Ω -cm is used to form the intermediate transfer belt 23.

Still further, in the exemplary embodiment, recording media fed from the feeder 61 of the recording media supplying device 24 are conveyed by an appropriate number of

conveying rolls (not shown) along the recording media conveying path 25, are position-aligned by a position aligning roll 62 and pass through the secondary transfer portion of the secondary transfer unit 52. After the unfixed toner images on the recording media are fixed by a fixing unit 66 by applying heat and pressure, for example, the recording media are discharged via a discharging roll 67 and accommodated into the discharged recording media receiver 26.

Numerals 38 (38a to 38d) in FIG. 3 designates a toner replenishing unit (toner cartridge) for replenishing new toner to the developing unit 34 of each of the image forming sections 22 (22a to 22d).

Image Forming Assembly

In the exemplary embodiment, as shown in FIGS. 4 to 6, the photoreceptor 31 is integrated with the charger 32, the developing unit 34, the cleaner 35 and the neutralizing unit 36 (see FIGS. 9 and 10) so as to form an image forming assembly 70. This image forming assembly 70 is detachably mounted on the assembly receiving section of the apparatus housing 21 so as to form the main section of the image forming section 22 for each color component.

In particular, in the exemplary embodiment, the image forming assembly 70 includes a photoreceptor assembly 71 incorporating the photoreceptor 31 and a developing assembly 72 rockably connected to this photoreceptor assembly 71 and incorporating the developing unit 34.

<Photoreceptor Assembly>

As shown in FIGS. 6B, 7 and 10, the photoreceptor assembly 71 has an accommodating container 80 for accommodating the photoreceptor 31. The charger 32, the cleaner 35 and the neutralizing unit 36 are disposed around the photoreceptor 31 inside the accommodating container 80.

Both ends of the rotation shaft of the photoreceptor 31 are rotatably supported at both ends of the accommodating container 80. When the image forming assembly 70 is mounted, one end of the rotation shaft of the photoreceptor 31 is connected to a driving mechanism (not shown) so as to driven.

In addition, the charger 32 has a configuration in which a charge container section 81 is provided in part of the accommodating container 80, and a charging roll 82 making contact with or adjacent to the surface of the photoreceptor 31 and a power supplying roll 83 for supplying power to the charging roll 82 are provided inside the charge container section 81.

Furthermore, the cleaner 35 has a configuration in which a cleaning container section 84 is provided in part of the accommodating container 80, a plate-shaped cleaning member 85 for scraping the toner remaining on the surface of the photoreceptor 31 is provided at the fringe of the opening in the cleaning container section 84, a recovery conveying member (for example, a mode having a spiral impeller provided around the rotation shaft thereof) 86 for conveying the remaining toner scraped by the cleaning member 85 into a recovery container (not shown) is disposed inside the cleaning container section 84.

Moreover, the neutralizing unit 36 has a configuration in which a neutralizing container section 87 is provided in part of the accommodating container 80, a neutralizing radiation lens 88 is held in this neutralizing container section 87, and neutralizing light from a neutralizing lamp (not shown) is guided to this neutralizing radiation lens 88 so that the neutralizing light is irradiated to the surface of the photoreceptor 31.

<Developing Assembly>

As shown in FIGS. 7 to 10, the developing assembly 72 has a developer container 90, being open toward the photoreceptor 31, for accommodating a two-component developer containing toner and carrier particles, wherein a developing roll

91 for holding and conveying the developer is disposed at a portion facing the opening of this developer container **90**, a pair of developer stirring members (for example, a mode having a spiral impeller provided around the rotation shaft thereof) **92** and **93** is disposed on the rear face side of the developing roll **91** inside the developer container **90**, and a layer thickness restricting member (for example, a layer thickness restricting roll) **94** is provided on the upstream side in the rotation direction from the developing portion of the developing roll **91** to restrict the thickness of the developer layer held on the developing roll **91**.

Furthermore, in the exemplary embodiment, the developer container **90** has a developer accommodating chamber **95** in which the developer is accommodated at the mounting time of the image forming assembly **70** and in which the developing roll **91** and the developer stirring members **92** and **93** are disposed; and an initial developer storing chamber **97**, disposed adjacent to this developer accommodating chamber **95** via the opening sections **96** (in the exemplary embodiment, multiple opening sections **96a** and **96b**), for storing the initial developer when the image forming assembly **70** is not mounted, wherein, when the image forming assembly **70** is not mounted, that is, when the developing assembly **72** is not used, the opening sections **96** (**96a** and **96b**) between the initial developer storing chamber **97** and the developer accommodating chamber **95** are hermetically sealed with hermetic seals **98** (in the exemplary embodiment, **98a** and **98b**).

The installation structure of the hermetic seals **98** will be described later.

Moreover, as shown in FIG. 6A, a drive transmission mechanism **99** formed of, for example, drive transmission gears, for driving the developing roll **91** and the developer stirring members **92** and **93** is provided outside the developer container **90** positioned on one axial end side of the developing roll **91**. The drive transmission mechanism **99** is covered with an external covering member **100**.

<Installation Structures of Photoreceptor Assembly and Developing Assembly>

In the exemplary embodiment, the photoreceptor assembly **71** and the developing assembly **72** are rockably supported via a connecting mechanism **73** as shown in FIG. 11B.

In the exemplary embodiment, the connecting mechanism **73** rockably connects the installation pieces at both longitudinal ends of the accommodating container **80** of the photoreceptor assembly **71** to the installation pieces at both longitudinal ends of the developer container **90** of the developing assembly **72** via a pivot shaft.

The connecting mechanism **73** is provided at a portion away from the portion at which the photoreceptor **31** is opposed to the developing roll **91**.

In addition, in the exemplary embodiment, tracking rolls **110**, having a diameter slightly larger than that of the developing roll **91**, for performing positional adjustment are provided at both ends of the developing roll **91**. The gap *g* between the developing roll **91** and the photoreceptor **31** is adjusted to a predetermined amount by making the tracking rolls **110** come into contact with the surface of the photoreceptor **31**.

Furthermore, as shown in FIG. 11A, a biasing spring **111** is provided between the developer container **90** of the developing assembly **72** and the accommodating container **80** of the photoreceptor assembly **71**, and this biasing spring **111** exerts a bias force in the direction of pressing the tracking rolls **110** to the photoreceptor **31**.

Protection Cover

In the exemplary embodiment, as shown in FIGS. 4 to 10, the photoreceptor assembly **71** serving as one component of the image forming assembly **70** is disposed so that the photoreceptor **31** is exposed at the portion opposed to the intermediate transfer belt **23** when the image forming assembly **70** is mounted.

Hence, a protection cover **74** for covering the exposed portion of the photoreceptor **31** is provided when the image forming assembly **70** is not mounted.

This protection cover **74** has a long plate-shaped member **120** extending in the axial direction of the photoreceptor **31** so as to correspond to the exposed portion of the photoreceptor **31** made of a synthetic resin. The transverse section of this long plate-shaped member **120** is formed into a shape curved in the circumferential direction of the photoreceptor **31**.

In the exemplary embodiment, the protection cover **74** has a bent member **121** integrated therewith and being bent at a nearly right angle on one longitudinal end side of the long plate-shaped member **120**, and a handle **122** is formed on this bent member **121**. In addition, the bent member **121** is provided with an opening **123** to avoid interference with the rotation bearing section **31a** of the photoreceptor **31**. Furthermore, the bent member **121** is provided with a positioning hole **124** into which a positioning protrusion **89** formed on the accommodating container **80** of the photoreceptor assembly **71** is inserted.

Moreover, rail-shaped guide members **131** and **132** are provided at the fringes of the openings of the accommodating container **80** of the photoreceptor assembly **71** and the developer container **90** of the developing assembly **72**, respectively, in the axial direction of the photoreceptor **31** and at portions corresponding to the exposed portion of the photoreceptor **31**. These guide members **131** and **132** may be provided in the axial direction of the photoreceptor **31** continuously or discontinuously.

Still further, both side sections of the protection cover **74**, formed in the width direction thereof and intersecting with the longitudinal direction thereof, are held by the guide members **131** and **132** of the assemblies **71** and **72**, whereby the protection cover **74** is made slidably movable along the guide members **131** and **132**.

In particular, in the exemplary embodiment, the protection cover **74** is moved and mounted along the guide members **131** and **132** from one longitudinal end side of the image forming assembly **70** so as to cover the exposed portion of the photoreceptor **31**. When removing the protection cover **74**, the protection cover **74** is moved along the guide members **131** and **132** in the direction opposite to the mounting direction so that the exposed portion of the photoreceptor **31** is opened.

Constraining Mechanism

A constraining mechanism **150** for constraining the movement of the protection cover **74** when the image forming assembly **70** is not mounted is provided as shown in FIGS. 12 to 14, for example, on one longitudinal end side of the protection cover **74**.

In the constraining mechanism **150**, a pair of elastic protruding pieces **151**, elastically deformable, is formed at the tip of the long plate-shaped member **120** of the protection cover **74**, and a hook-shaped pawl **152** extending outwards is formed at the protruding end of the elastic protruding piece **151**. On the other hand, constrained pieces **153** over which the pawls **152** of the pair of elastic protruding pieces **151** ride and with which the pawls **152** engage are formed at the back side ends of the guide members **131** and **132** of the assemblies **71** and **72**. Guide groove pieces **154** (see FIG. 8) for allowing the insertion of the pawls **152** of the pair of elastic protruding

11

pieces **151** are provided at the front side ends of the guide members **131** and **132** of the assemblies **71** and **72**.

Constraint-releasing Mechanism

In the exemplary embodiment, as shown in FIGS. **14A** and **14B**, a constraint-releasing mechanism **160** is provided to release the constraining state obtained by the constraining mechanism **150** of the protection cover **74** when the image forming assembly **70** is mounted.

As shown in FIGS. **14A** and **14B**, in this constraint-releasing mechanism **160**, a pair of releasing protruding pieces **161** is provided on the housing **21** at portions corresponding to the pawls **152** of the pair of elastic protruding pieces **151** of the constraining mechanism **150** of the protection cover **74**. The pawls **152** of the elastic protruding pieces **151** are made contact with the releasing protruding pieces **161**, whereby the elastic protruding pieces **151** are elastically deformed so that the pawls **152** become closer to each other and so that the pawls **152** are disengaged from the constrained pieces **153**.

Toner Replenishing Mechanism

In the exemplary embodiment, between the developing assembly **72** of the image forming assembly **70** and the toner replenishing unit **38**, a toner replenishing mechanism **170** capable of making the connection between the two when the image forming assembly **70** is mounted is provided as shown in FIGS. **15** and **16**.

This toner replenishing mechanism **170** is provided with a flexible pipe **171** made of a flexible material and communicating with the developer container **90**. This flexible pipe **171** is provided with a shutter mechanism **172** (having a mode in which an input port **174** is opened in a shutter base **173**, a shutter member **175** is movably provided on the shutter base **173**, and the shutter member **175** is biased by a biasing spring **176** in a direction of closing the input port **174**). On the other hand, the toner replenishing unit **38** is provided with a shutter-releasing mechanism **177** (having a mode in which a shutter-releasing member **179** making contact with the shutter member **175** is provided at the tip of a connection pipe **178** extending from the toner replenishing unit **38**, and this shutter-releasing member **179** is provided with a positioning member **180** for positioning the shutter base **173** so that the positioning member **180** is pressed toward the shutter base **173** by a biasing spring **181**) at a portion making contact with the shutter member **175** of the shutter mechanism **172**.

In the exemplary embodiment, since the shutter mechanism **172** can swing with respect to the flexible pipe **171**, when the image forming assembly **70** is mounted, the shutter mechanism **172** is positioned at a position corresponding to the shutter-releasing mechanism **177**, and the shutter member **175** of the shutter mechanism **172** is moved by the shutter-releasing mechanism **177** so as to open the input port **174**.

Installation Structure of Hermetic Seals

In the exemplary embodiment, as shown in FIG. **9** and FIGS. **17A** to **17E**, the hermetic seals **98** (**98a** and **98b**) of the developing assembly **72** have hermetic sealing sections **186** peelably attached to the fringes of the opening sections **96** (**96a** and **96b**) of the developer container **90** via a heat-welding adhesive **185**, for example, and non-adhesive extended bent sections **187** being bent from the hermetic sealing sections **186**. Gripping sections **188** are installed at the tips of these extended bent sections **187**.

In the exemplary embodiment, the application pattern **189** of the adhesive **185** applied between the hermetic sealing section **186** and the extended bent section **187** is formed into a mountain shape toward the side from which the hermetic sealing section **186** begins to be peeled so that the force for peeling the hermetic sealing section **186** is reduced.

12

In addition, in the exemplary embodiment, as shown in FIG. **8**, the gripping sections **188** of the hermetic seals **98** (**98a** and **98b**) can be extracted from slits **101** (see FIG. **5**) provided in the outer covering member **100** of the developing assembly **72**.

Furthermore, in the exemplary embodiment, since slits **125** corresponding to the gripping sections **188** of the hermetic seals **98** (**98a** and **98b**) are provided in the bent member **121** of the protection cover **74**, the hermetic seals **98** may be removed after the protection cover **74** is removed, or the hermetic seals **98** may also be removed before the protection cover **74** is removed.

State when Image Forming Assembly is not Mounted

In the exemplary embodiment, the image forming assembly **70** is held on the guide members **131** and **132** while the protection cover **74** is lying astride the photoreceptor assembly **71** and the developing assembly **72** when the image forming assembly is not mounted.

Hence, as shown in FIGS. **11A** and **11B**, since the positional relationship between the photoreceptor assembly **71** and the developing assembly **72** is restricted by the protection cover **74**, when the image forming assembly **70** is stored or conveyed, the tracking rolls **110** of the developing assembly **72** do not unnecessarily collide with the photoreceptor **31** of the photoreceptor assembly **71**. Furthermore, the photoreceptor assembly **71** and the developing assembly **72** can be held in a direction away from each other by making the width of the protection cover **74** in a direction orthogonal to the longitudinal direction thereof larger than the distance between the guide members **131** and **132**.

Mounting Processing of Image Forming Assembly

In the exemplary embodiment, as shown in FIGS. **18** and **19**, when the image forming assembly **70** is mounted on the receiving section U of the housing **21**, the front door **190** of the housing **21** is opened, and a door **191** for opening/closing the receiving section U is opened. Then, the image forming assembly **70** should only be inserted into the receiving section U so that the image forming assembly **70** is pushed to a predetermined mounting position.

In this state, the image forming assembly **70** is mounted on the receiving section U. In the exemplary embodiment, since the constrained state of the protection cover **74** by the constraining mechanism **150** is released by the constraint-releasing mechanism **160** of the receiving section U, the protection cover **74** should only be extracted in the extraction direction thereof by grasping and pulling the handle **122** of the protection cover **74**.

In this state, the protection cover **74** is moved slidably along the guide members **131** and **132** in the extraction direction, and the movement locus of the protection cover **74** is stable. Hence, for example, in a mode in which the protection cover **74** is disposed so as not make contact with in the photoreceptor **31**, the protection cover **74** does not unnecessarily make contact with the photoreceptor **31** and peripheral components around the protection cover **74**.

In addition, in the exemplary embodiment, in a state in which the image forming assembly **70** is mounted on the receiving section U, after the protection cover **74** is removed or before the protection cover **74** is removed, the hermetic sealing state by the hermetic seals **98** (**98a** and **98b**) should only be released by hold and pulling the gripping sections **188** of the hermetic seals **98** (**98a** and **98b**).

Furthermore, in the exemplary embodiment, in a state in which the image forming assembly **70** is mounted on the receiving section U, the developing assembly **72** and the toner replenishing unit **38** are connected to each other via the toner replenishing mechanism **170** while they are position-aligned.

13

Hence, when the image forming assembly 70 is mounted, the connection work for the toner replenishing path is not required to be performed separately.

Moreover, in the exemplary embodiment, unless the protection cover 74 is removed, the gripping sections 188 make contact with the door 191, and the door 191 cannot be closed. Hence, there is no fear of mounting the image forming assembly 70 while the protection cover 74 remains unremoved.

Exemplary Embodiment 2

FIGS. 20 to 22 show the overall configuration of an image forming assembly according to Exemplary Embodiment 2.

In the figures, the image forming assembly 70 is approximately similar to that according to Exemplary Embodiment 1 but is different from that according to Exemplary Embodiment 1 in that the tips of the hermetic seals 98 (98a and 98b) of the developing assembly 72 are adhered to the fixed portion 126 of the bent member 121 of the protection cover 74 by an adhesive, for example.

Components similar to those according to Exemplary Embodiment 1 are designated by similar numerals, and the detailed descriptions thereof are omitted.

Hence, in this exemplary embodiment, as shown in FIG. 23, after the image forming assembly 70 is mounted on the receiving section U (see FIG. 18) of the housing 21, the protection cover 74 should only be extracted in a direction opposite to the mounting direction of the image forming assembly 70.

In this state, by the extraction of the protection cover 74, the photoreceptor 31 of the image forming assembly 70 can be set in an exposed state in which imaging is possible, and the hermetic seals 98 (98a and 98b) can be removed from the developing assembly 72 when the protection cover 74 is removed.

At this time, during the work for removing the protection cover 74, large peeling forces H_1 and H_2 are applied to the multiple hermetic seals 98 (98a and 98b), respectively, at the start of peeling the seals.

In this state, assuming that the timings for starting the peeling of the multiple hermetic seals 98 (98a and 98b) are the same as shown in FIGS. 24A and 24B, the peak points of the peeling forces H_1 and H_2 exerted when the peeling of the multiple hermetic seals 98 (98a and 98b) is started overlap each other as shown in FIG. 25A. Because of this overlap, the force for extracting the protection cover 74 becomes large.

On the other hand, in the case that the timings for starting the peeling of the multiple hermetic seals 98 (98a and 98b) are different as shown in FIGS. 24A and 24C, the peak points of the peeling forces H_1 and H_2 exerted when the peeling of the multiple hermetic seals 98 (98a and 98b) is started become different as shown in FIG. 25B. Because of this difference, the force for extracting the protection cover 74 is reduced.

In FIGS. 25A and 25B, S_1 and S_2 correspond to the hermetic seals 98a and 98b.

Furthermore, in a mode in which the timings for starting the peeling of the multiple hermetic seals 98 (98a and 98b) are the same or different, it is preferable that the constraint-releasing mechanism 160 for releasing the constraining mechanism 150 of the protection cover 74 (as in Exemplary Embodiment 1) should be ingeniously modified, for example, as shown in FIGS. 26A and 26B so that, in addition to the releasing protruding pieces 161, push-back protruding pieces 162 for pushing back the elastic protruding pieces 151, the constrained state of which has been released by the releasing protruding pieces 161, are formed, whereby, as the constrained state of the constraining mechanism 150 is released

14

by the constraint-releasing mechanism 160, a push-back force is applied to the protection cover 74 in the extraction direction thereof.

With the exemplary embodiment, it is preferable that the push-back force is applied to the protection cover 74 by the constraint-releasing operation by the constraint-releasing mechanism 160, whereby an initial push-back amount can be applied to the protection cover 74. Hence, this configuration is preferable in that the peeling forces applied when the peeling of the hermetic seals 98 (98a and 98b) is started are reduced.

What is claimed is:

1. An image forming assembly, which is detachably mounted on a receiving section provided beforehand in a housing of an image forming apparatus and forms an image on a transfer medium, the image forming assembly comprising:

a photoreceptor assembly that comprises:

a photoreceptor, and

an accommodating container that accommodates at least the photoreceptor and holds the photoreceptor with a part of the photoreceptor being exposed;

a developing assembly that comprises:

a developing member, and

a developer container that accommodates at least the developer member and holds the developing member so as to position the developing member at a portion opposed to the photoreceptor;

a connecting mechanism that connects the photoreceptor assembly to the developing assembly so that a distance between the photoreceptor and the developing member is changeable;

a protection member that covers and protects the exposed portion of the photoreceptor; and

guide members that are respectively provided on the accommodating container and the developer container, and that detachably guide the protection member with the protection member lying astride the two assemblies, wherein when the protection member is in a constrained state where the protection member covers the photoreceptor, the developing member and the photoreceptor are positioned away from each other.

2. The image forming assembly according to claim 1, wherein the guide members are provided on the accommodating container and the developer container, extend in an attaching/detaching direction of the image forming assembly and slidably guide the protection member.

3. The image forming assembly according to claim 1, further comprising:

a constraining mechanism that constrains a movement of the protection member with respect to the guide members.

4. The image forming assembly according to claim 1, further comprising:

a position adjusting member that maintains a positional relationship between the developing member and the photoreceptor constant during image forming.

5. The image forming assembly according to claim 1, wherein

the developing assembly comprises, in the developer container,

a developer accommodating chamber that accommodates a developer, and

an initial developer storing chamber that is adjacent to the developer accommodating chamber via at least one opening section and stores an initial developer before use, and when the developing assembly is not used, the

15

at least one opening section between the initial developer storing chamber and the developer accommodating chamber is hermetically sealed with at least one hermetic sealing member, and the at least one hermetic sealing member is fixed to the protection member so as to be movable together with the protection member.

6. The image forming assembly according to claim 5, wherein

when the protection member is removed from the guide members, the at least one hermetic sealing member is moved together with the protection member so that the opening section between the initial developer storing chamber and the developer accommodating chamber is opened and the initial developer is supplied into the developer accommodating chamber.

7. The image forming assembly according to claim 5, further comprising:

a constraining mechanism that constrains a movement of the protection member with respect to the guide members, wherein when the constrained state of the protection member by the constraining mechanism is released, the protection member starts moving along the guide members, and thereby the hermetic sealing state by the at least one hermetic sealing member is released.

8. The image forming assembly according to claim 5, wherein

the at least one opening section is a plurality of opening sections, and the at least one hermetic sealing member is a plurality of hermetic sealing members, which are provided for the plurality of opening sections.

9. The image forming assembly according to claim 8, wherein

releasing operations of the hermetic sealing states by the plurality of the hermetic sealing members start at different times in accordance with a removal of the protection member.

10. An image forming apparatus comprising:
a housing that has a receiving section; and
the image forming assembly according to claim 1 detachably mounted on the receiving section.

11. The image forming apparatus according to claim 10, wherein

the image forming assembly comprises a constraining mechanism that constrains a movement of the protection member with respect to the guide members, and the housing is provided with a constraint-releasing mechanism that is capable of releasing the constrained state of

16

the protection member by the constraining mechanism when the image forming assembly is mounted on the receiving section.

12. The image forming apparatus according to claim 10, wherein

the housing has a door that is opened and closed when the image forming assembly is mounted on and dismounted from the receiving section,

the protection member is removable from the image forming assembly when the image forming assembly is mounted on the receiving section of the housing, and prevents the door of the housing from being closed in a state that the protection member is not removed from the image forming assembly.

13. An image forming assembly, which is detachably mounted on a receiving section provided beforehand in a housing of an image forming apparatus and forms an image on a transfer medium, the image forming assembly comprising:

- a photoreceptor assembly that comprises:
 - a photoreceptor, and
 - an accommodating container that accommodates the photoreceptor and has an opening, a part of the photoreceptor being exposed via the opening;
- a developing assembly that comprises:
 - a developing member, and
 - a developer container that accommodates the developing member and the developing member is disposed opposed to the photoreceptor;
- a protection member that covers the exposed portion of the photoreceptor;
- guide members that are respectively provided on the accommodating container and the developer container, and that detachably guide the protection member with the protection member lying astride the photoreceptor assembly and the developing assembly; and
- a positioning portion that formed on an end side of the image forming assembly, wherein the protection member comprising an end cover that covers the end side of the image forming assembly, the end cover comprising a positioned portion that engages with the positioning portion so that the protection member is positioned by the positioning portion.

14. The imaging forming assembly according to claim 13, wherein when the protection member is in a constrained state where the protection member covers the photoreceptor, the developing member and the photoreceptor are positioned away from each other.

* * * * *