

US008267903B2

(12) **United States Patent**  
**Anderson et al.**

(10) **Patent No.:** **US 8,267,903 B2**  
(45) **Date of Patent:** **Sep. 18, 2012**

(54) **CASING**

(75) Inventors: **Gregor John McLennan Anderson**,  
Ware (GB); **John Mitchell**, London  
(GB)

(73) Assignee: **Zogenix, Inc.**, Emeryville, CA (US)

(\*) Notice: Subject to any disclaimer, the term of this  
patent is extended or adjusted under 35  
U.S.C. 154(b) by 0 days.

(21) Appl. No.: **13/011,240**

(22) Filed: **Jan. 21, 2011**

(65) **Prior Publication Data**

US 2011/0118663 A1 May 19, 2011

**Related U.S. Application Data**

(63) Continuation of application No. 10/506,959, filed as  
application No. PCT/EP03/02876 on Mar. 18, 2003,  
now Pat. No. 7,901,385.

(30) **Foreign Application Priority Data**

Mar. 20, 2002 (GB) ..... 0206560.5

(51) **Int. Cl.**

**A61M 5/315** (2006.01)

(52) **U.S. Cl.** ..... **604/220**; 604/68; 604/110

(58) **Field of Classification Search** ..... 604/68-72,  
604/110, 192-198, 220, 232

See application file for complete search history.

(56) **References Cited**

**U.S. PATENT DOCUMENTS**

3,625,208 A 12/1971 Frost et al.  
3,782,380 A 1/1974 Van Der Gaast

4,596,556 A	6/1986	Morrow et al.	
4,623,332 A	11/1986	Lindmayer et al.	
4,941,880 A	7/1990	Burns	
5,499,972 A	3/1996	Parsons	
5,514,097 A	5/1996	Knauer	
5,865,795 A *	2/1999	Schiff et al. ....	604/70
5,879,327 A	3/1999	DeFarges et al.	
5,891,086 A	4/1999	Weston	
6,447,475 B1 *	9/2002	Castellano ....	604/68
6,558,348 B2	5/2003	Parsons	
6,585,685 B2	7/2003	Staylor et al.	
6,613,010 B2	9/2003	Castellano	
6,641,554 B2	11/2003	Landau	
6,669,664 B2	12/2003	Slate	
6,755,220 B2	6/2004	Castellano et al.	
6,824,526 B2	11/2004	Castellano	
6,939,319 B1	9/2005	Anstead et al.	
6,979,310 B2	12/2005	Navelier et al.	
7,018,356 B2	3/2006	Wise et al.	
2001/0004681 A1	6/2001	Landau	

(Continued)

**FOREIGN PATENT DOCUMENTS**

EP 1 125 593 8/2001

(Continued)

*Primary Examiner* — Theodore Stigell

*Assistant Examiner* — Gerald Landry, II

(74) *Attorney, Agent, or Firm* — Karl Bozicevic; Bozicevic,  
Field & Francis LLP

(57) **ABSTRACT**

A casing for an injection device of the type having a safety  
device which prevents operation of the device, incorporating  
an actuator means by which the safety means of the device can  
be actuated to allow operation of the device. Also a casing for  
a medicament container having an opening closed prior to use  
by a break-off tip, having relatively moveable first and second  
casing parts, which on relative movement apply a breaking  
force to the break-off tip. A preferred embodiment includes  
both such features.

**18 Claims, 9 Drawing Sheets**

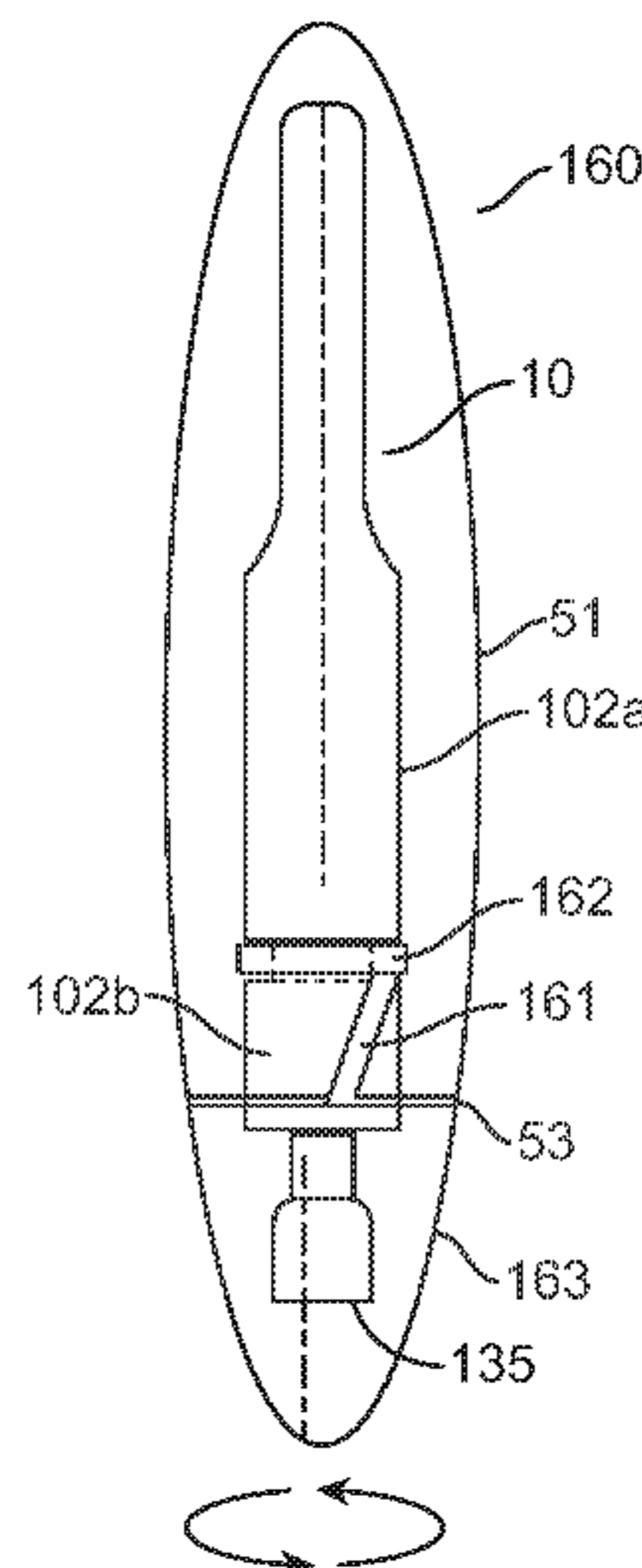

# US 8,267,903 B2

Page 2

---

## U.S. PATENT DOCUMENTS

2001/0004682	A1*	6/2001	Weston .....	604/72
2001/0031945	A1*	10/2001	Haar et al. ....	604/68
2002/0099329	A1	7/2002	Castellano	
2002/0123718	A1	9/2002	Landau	
2002/0151840	A1	10/2002	Castellano	
2002/0161334	A1	10/2002	Castellano et al.	
2002/0188251	A1	12/2002	Staylor et al.	
2003/0078535	A1	4/2003	Castellano	
2003/0083612	A1	5/2003	Castellano	
2003/0093030	A1	5/2003	Landau	
2003/0199814	A1	10/2003	Parsons et al.	

2004/0015126	A1	1/2004	Zierenberg et al.
2004/0087896	A1	5/2004	Wise et al.
2004/0127846	A1	7/2004	Dunn et al.

## FOREIGN PATENT DOCUMENTS

JP	2000-508189	7/2000
JP	2001-224684	8/2001
WO	91/12839	9/1991
WO	96/24398	8/1996
WO	9737705	10/1997

\* cited by examiner

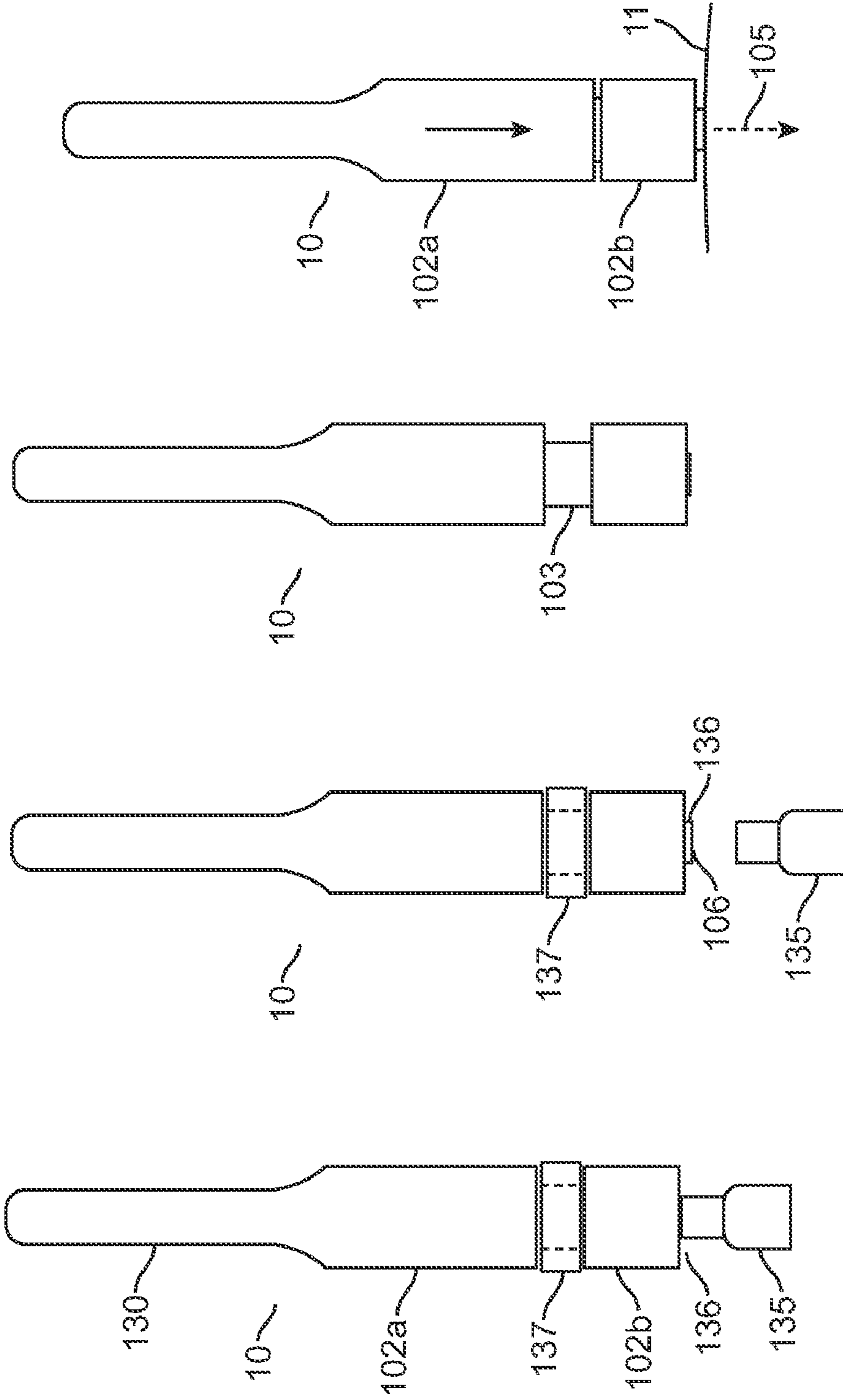

FIG. 4

FIG. 3

FIG. 2

FIG. 1

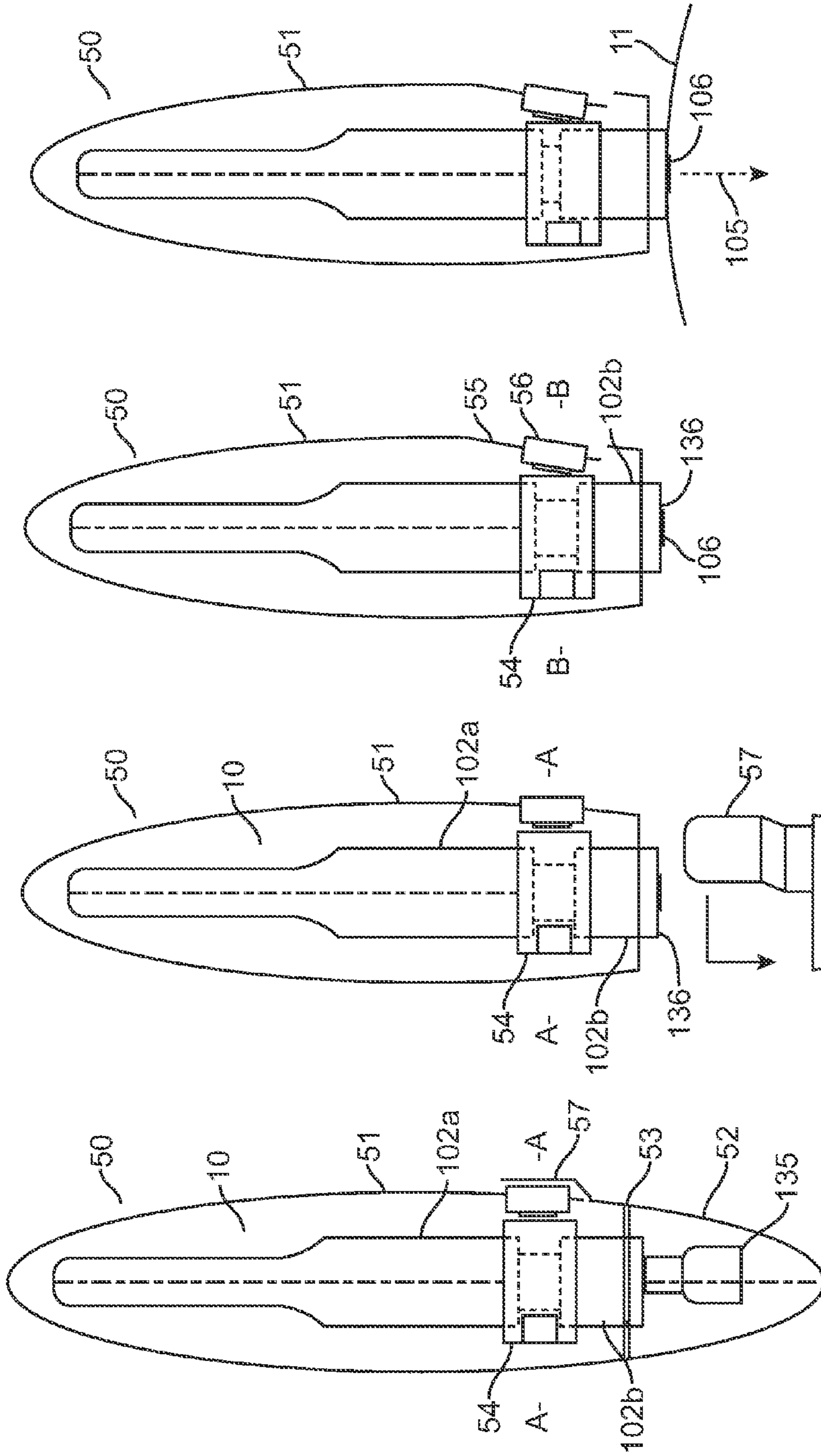

FIG. 5

FIG. 6

FIG. 7

FIG. 8

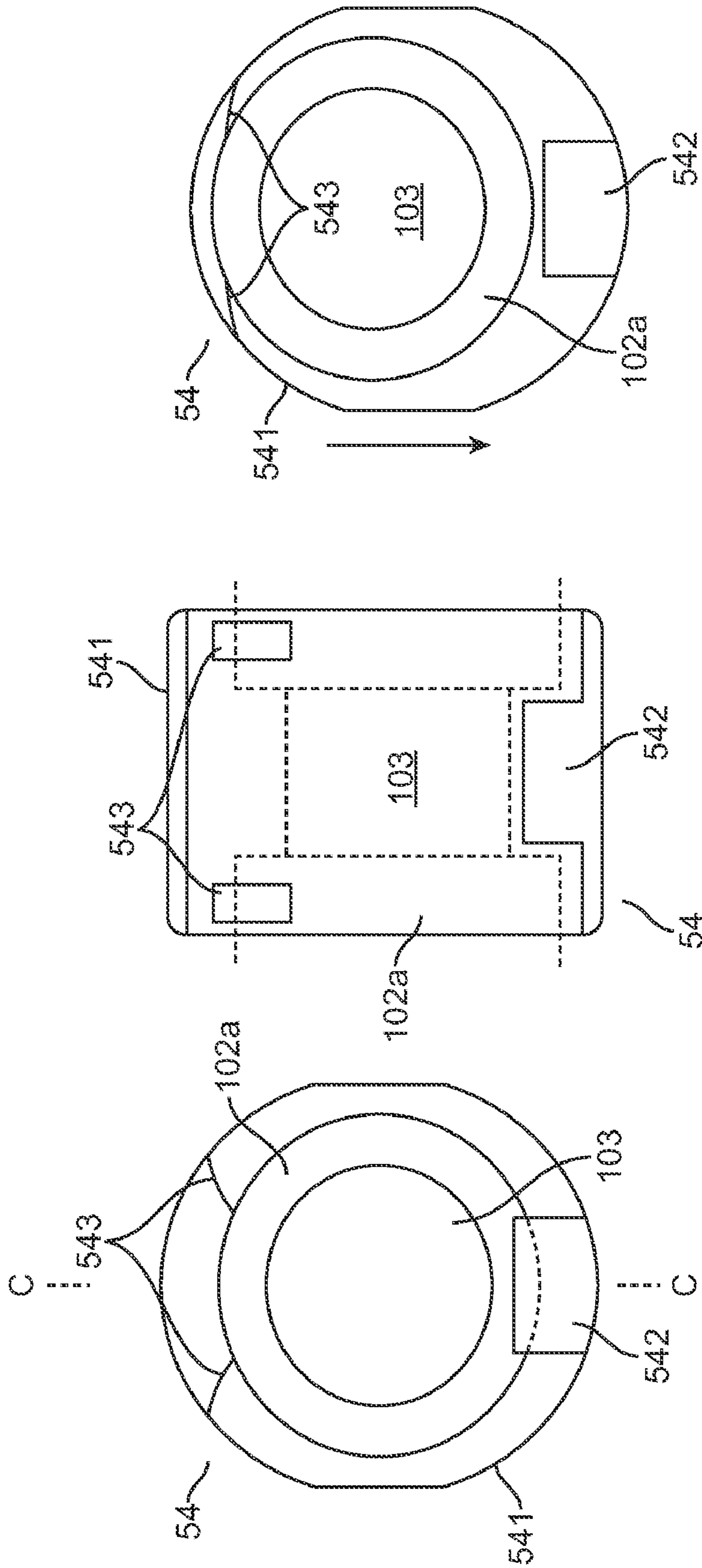

FIG. 9A

FIG. 9B

FIG. 9C

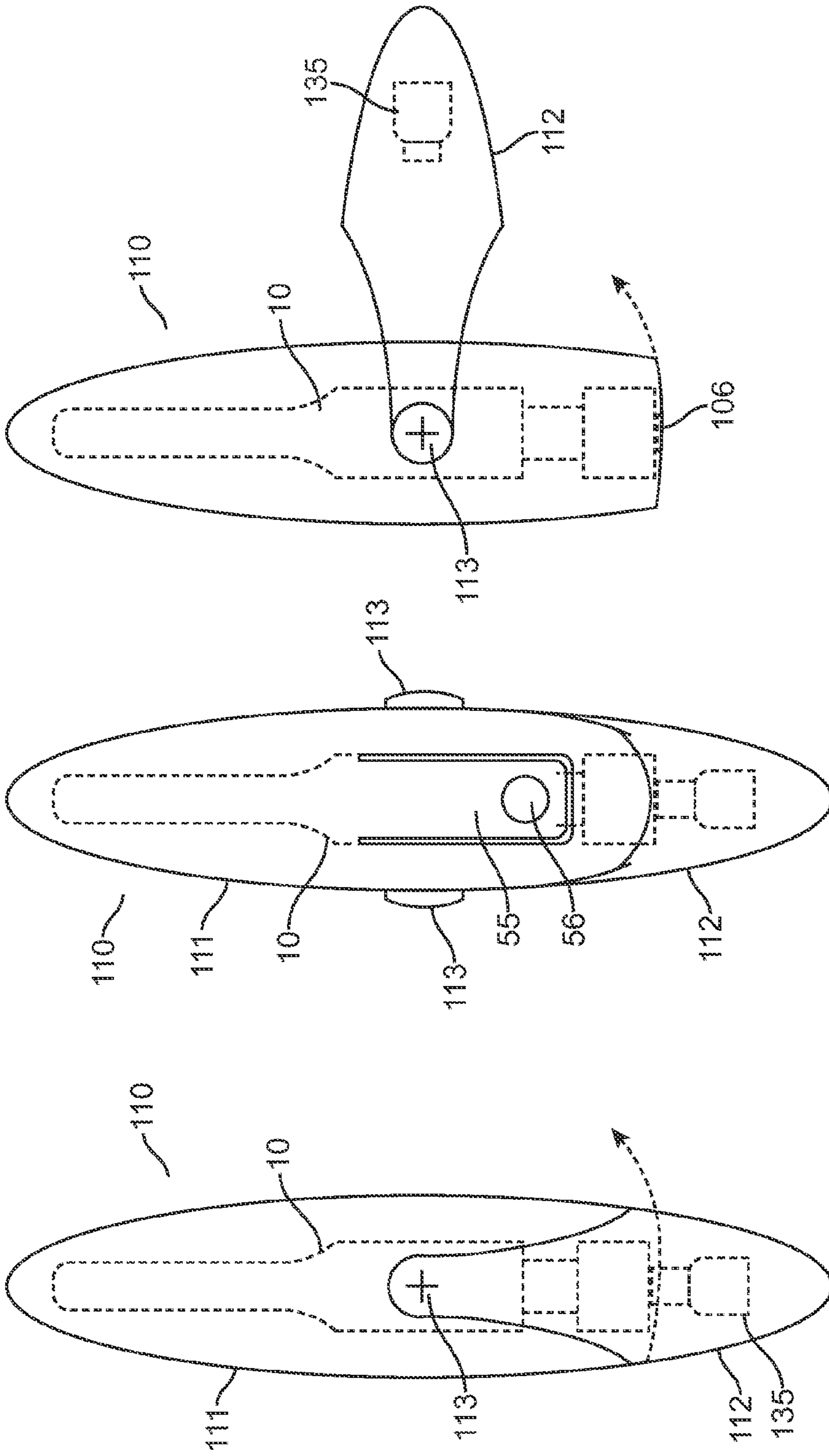

FIG. 10

FIG. 11

FIG. 11A

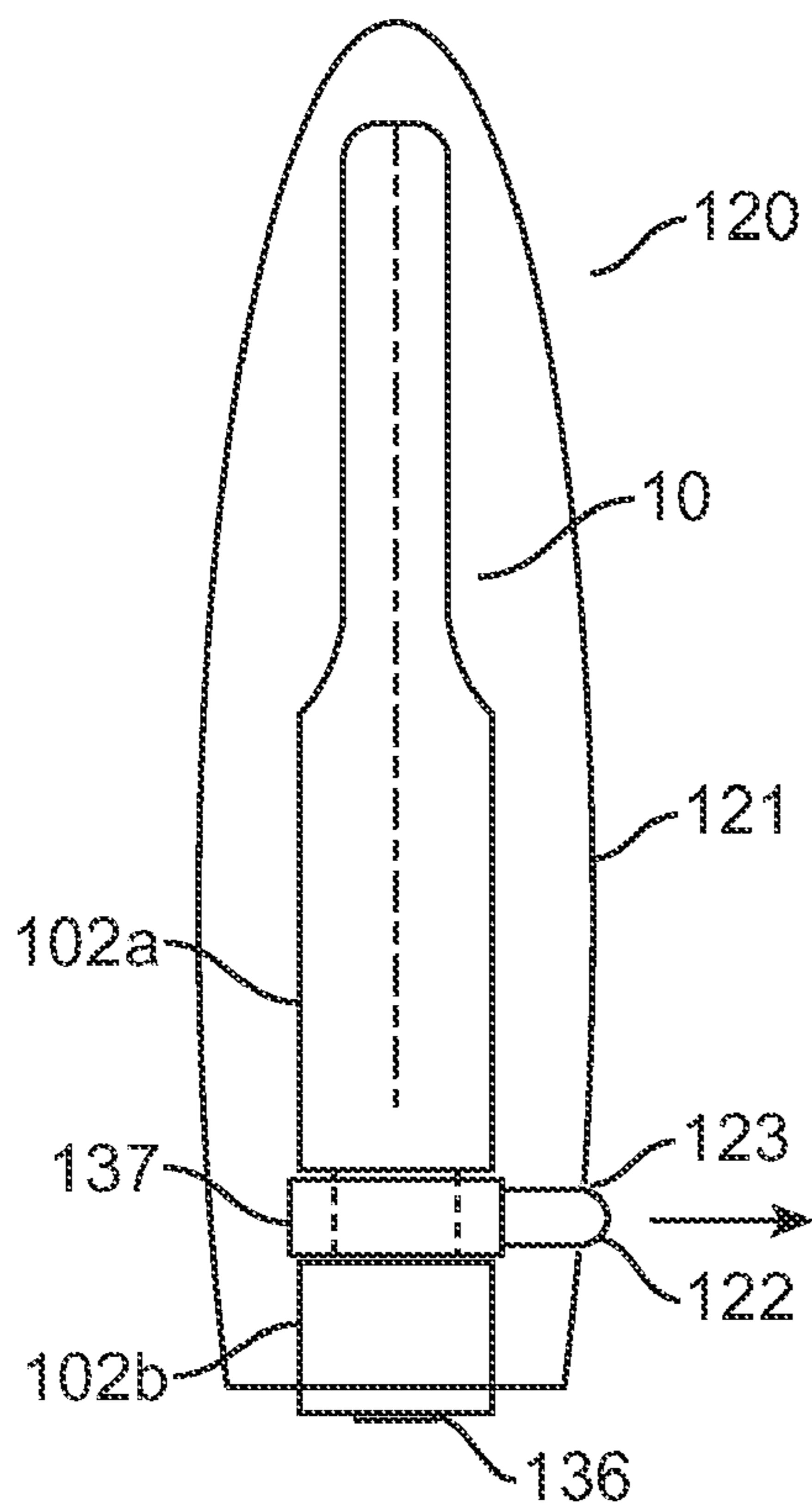

FIG. 12

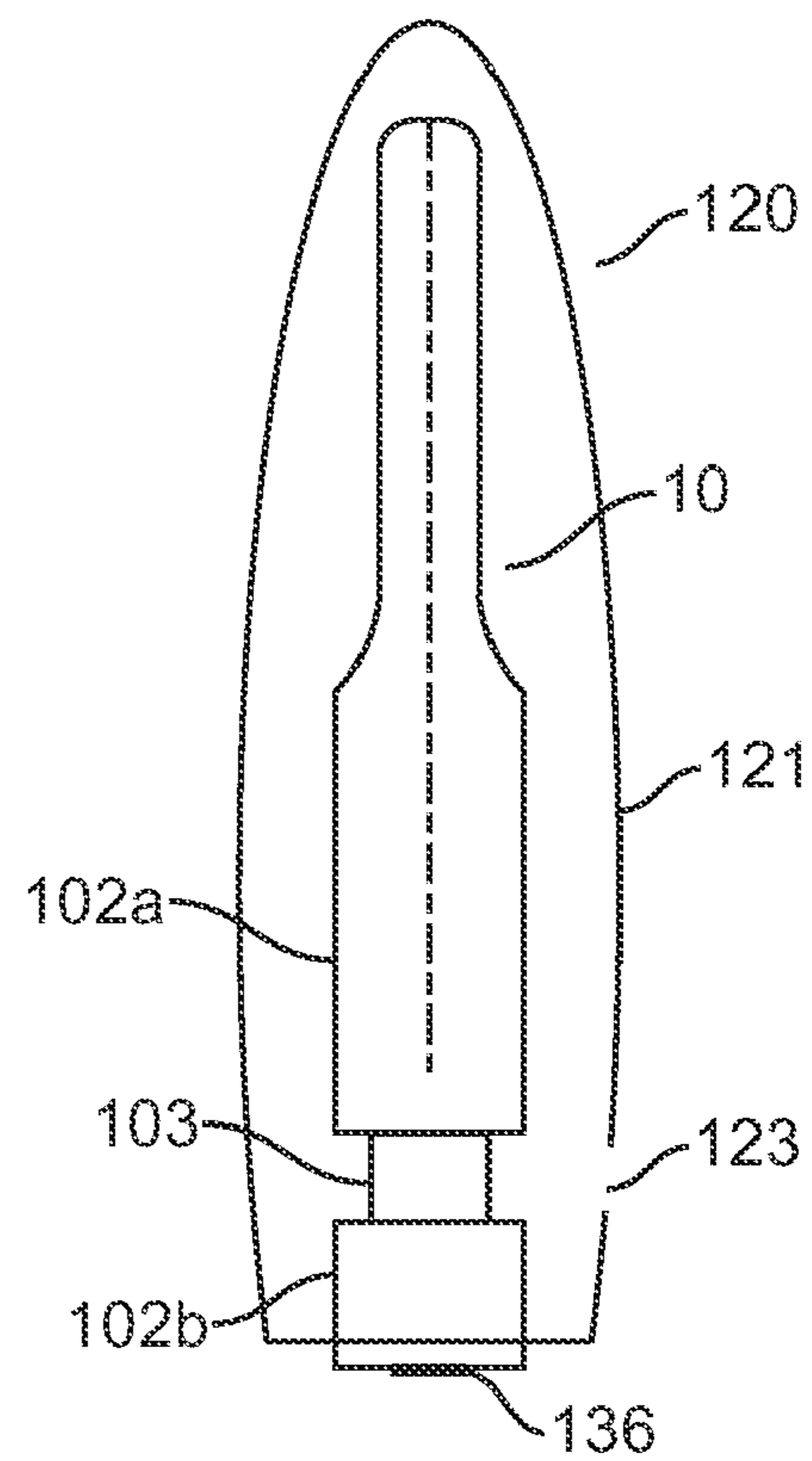

FIG. 13

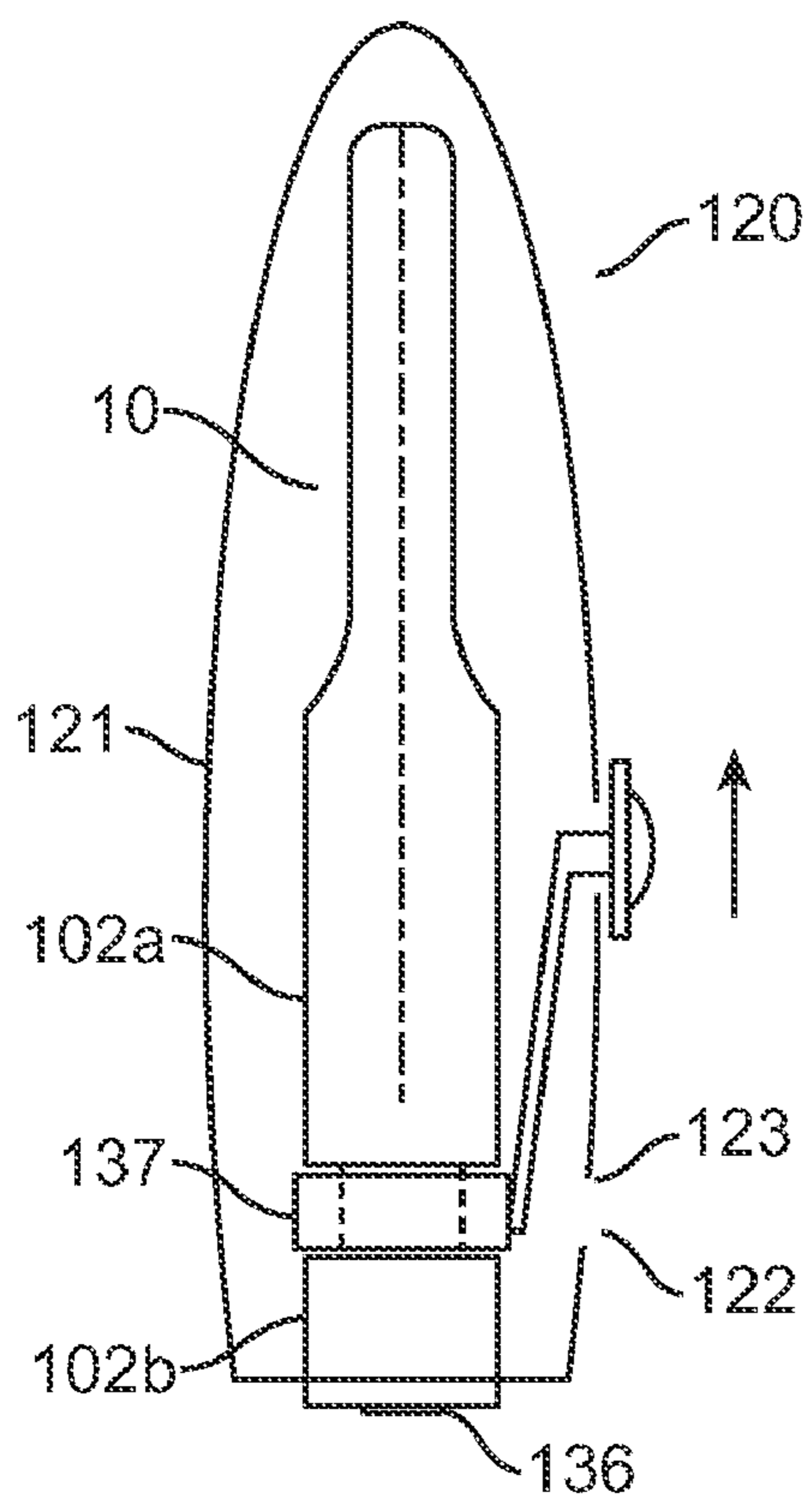

FIG. 14

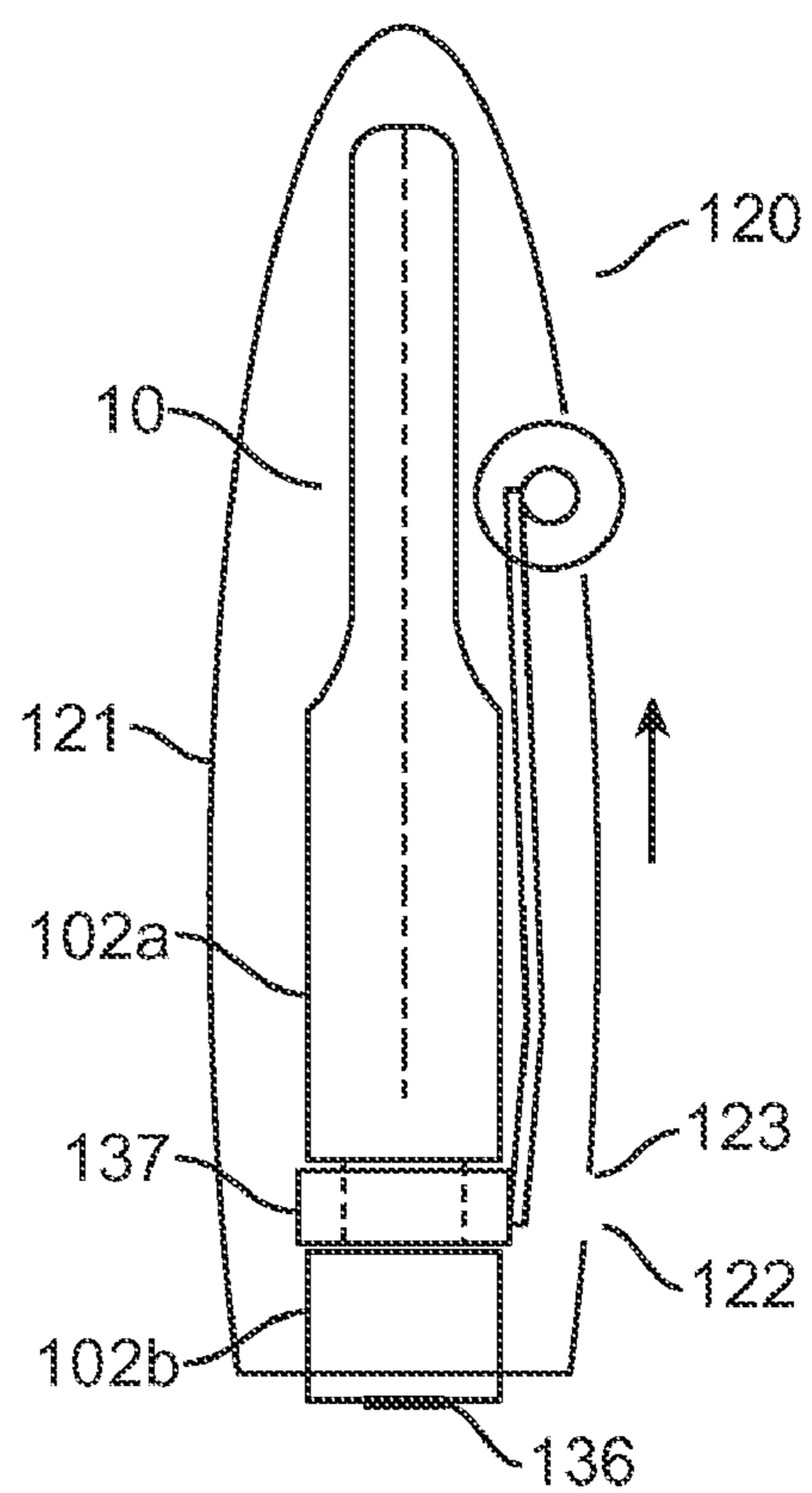

FIG. 15



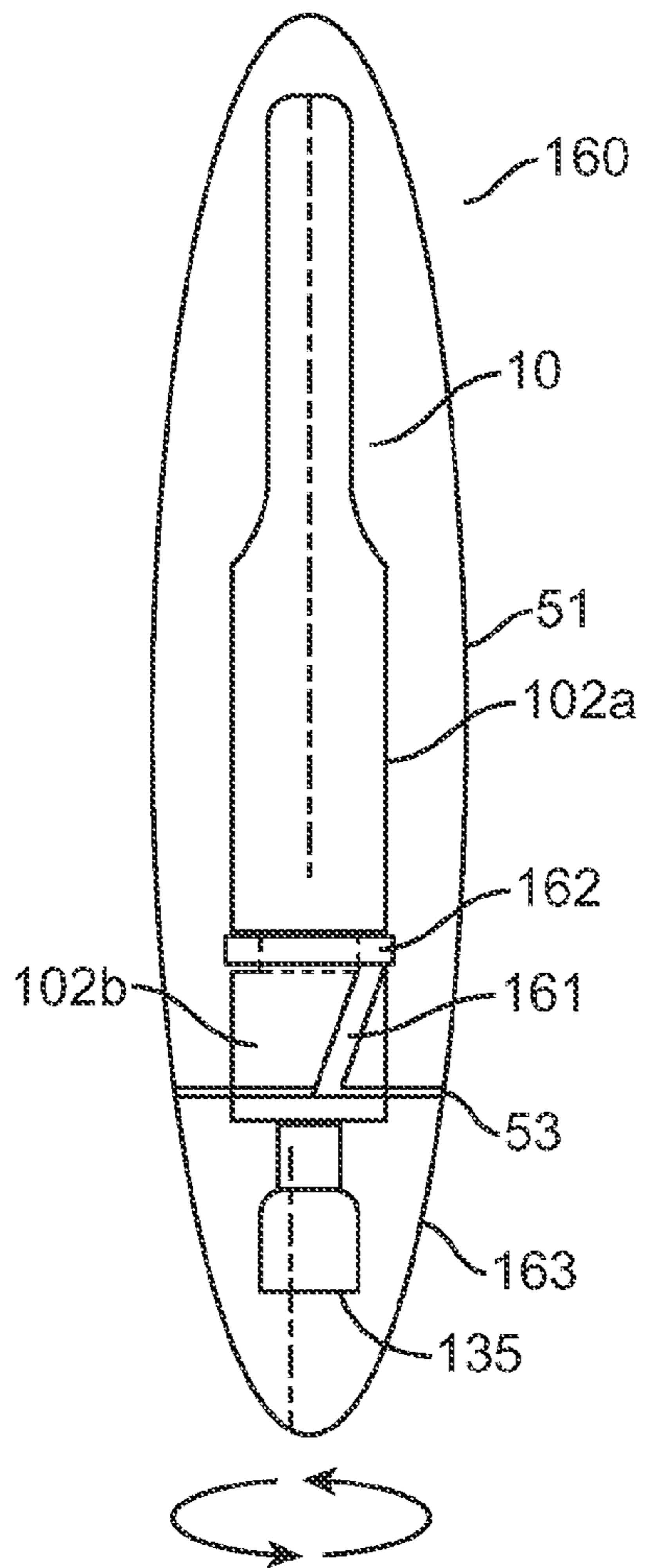

FIG. 16

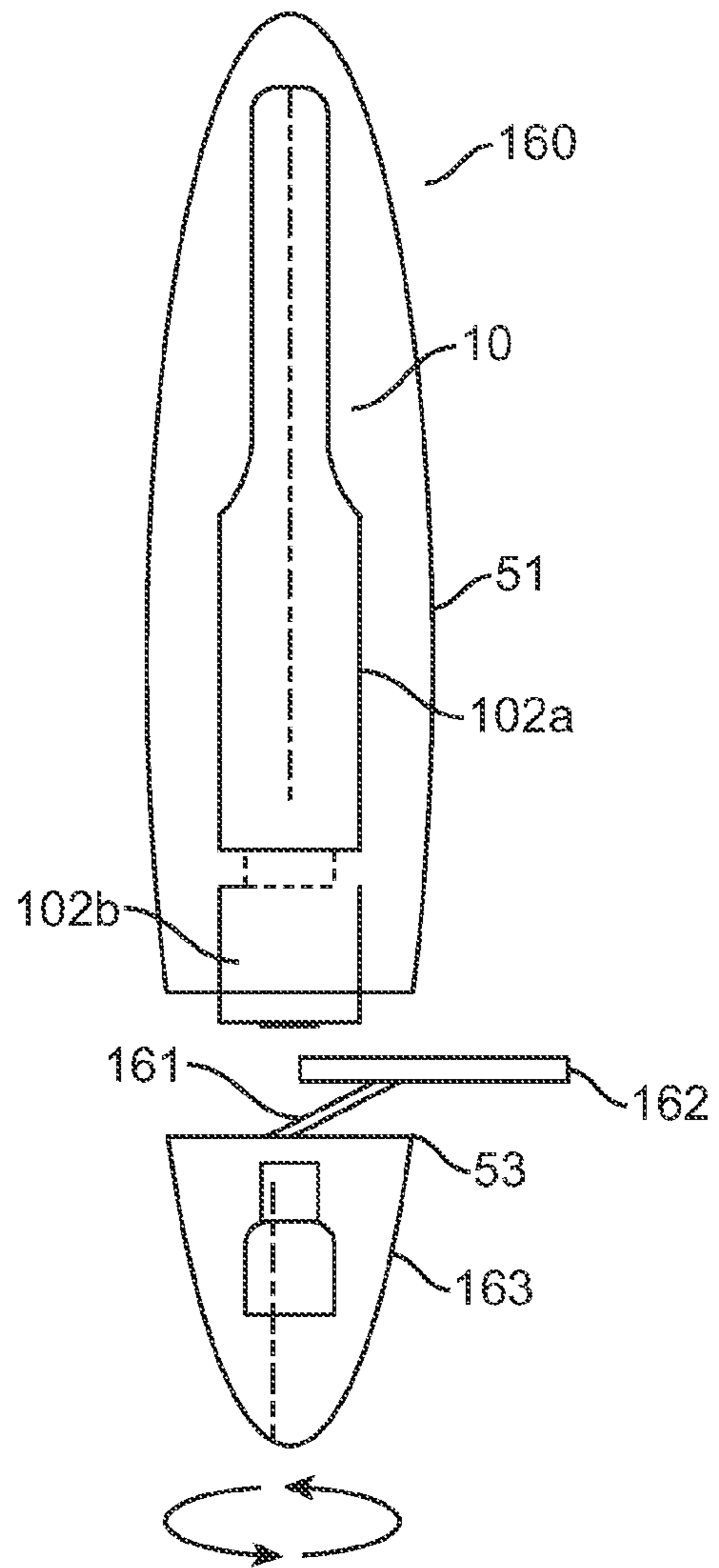

FIG. 16A

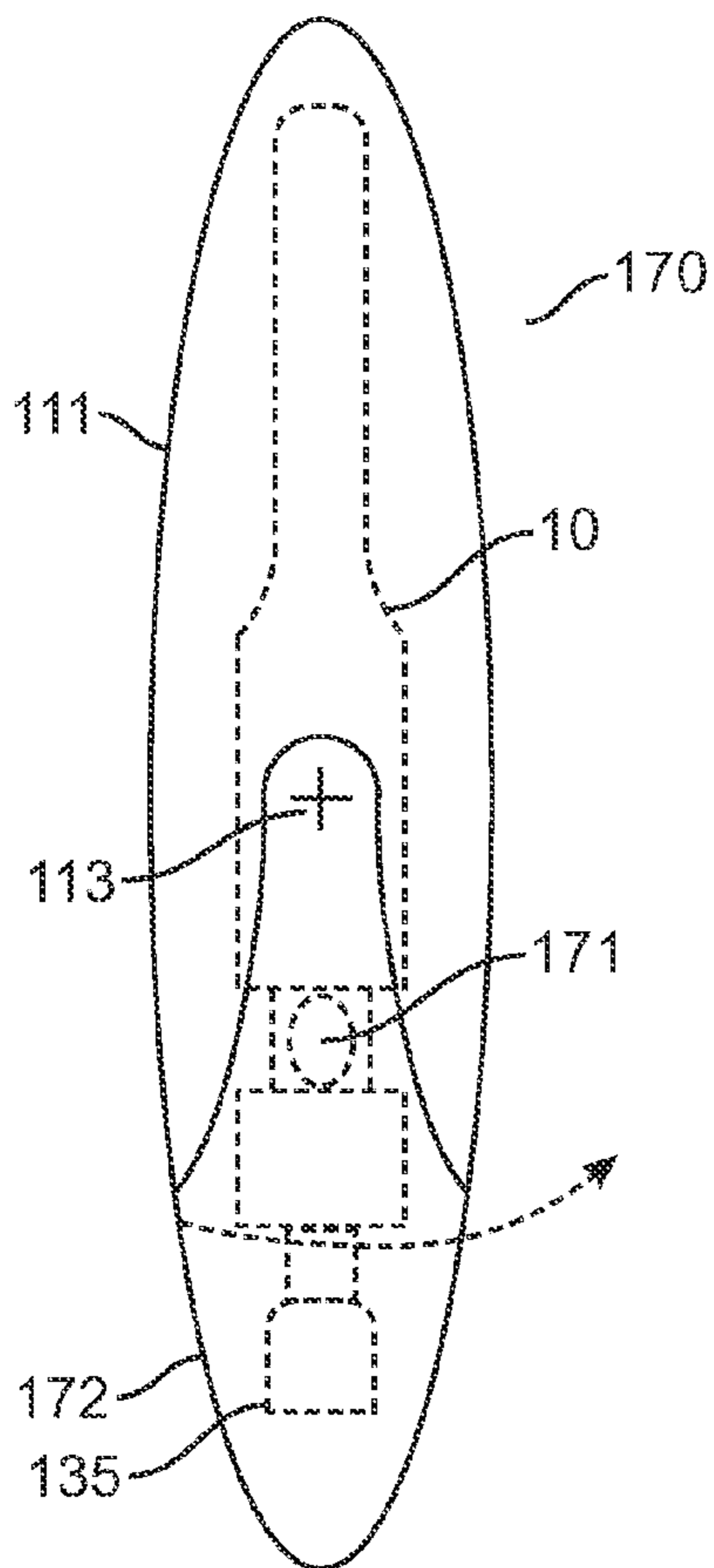

FIG. 17

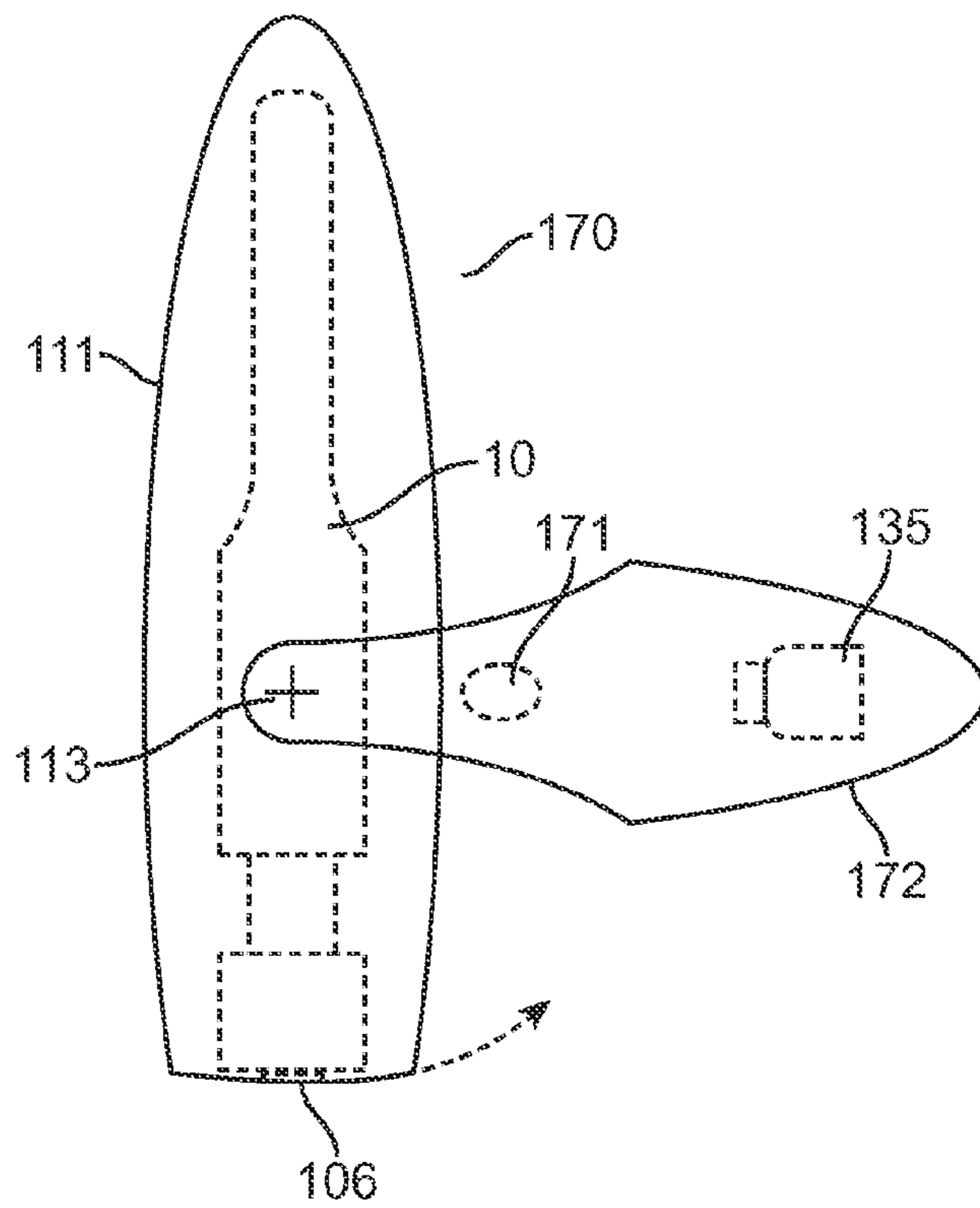

FIG. 17A

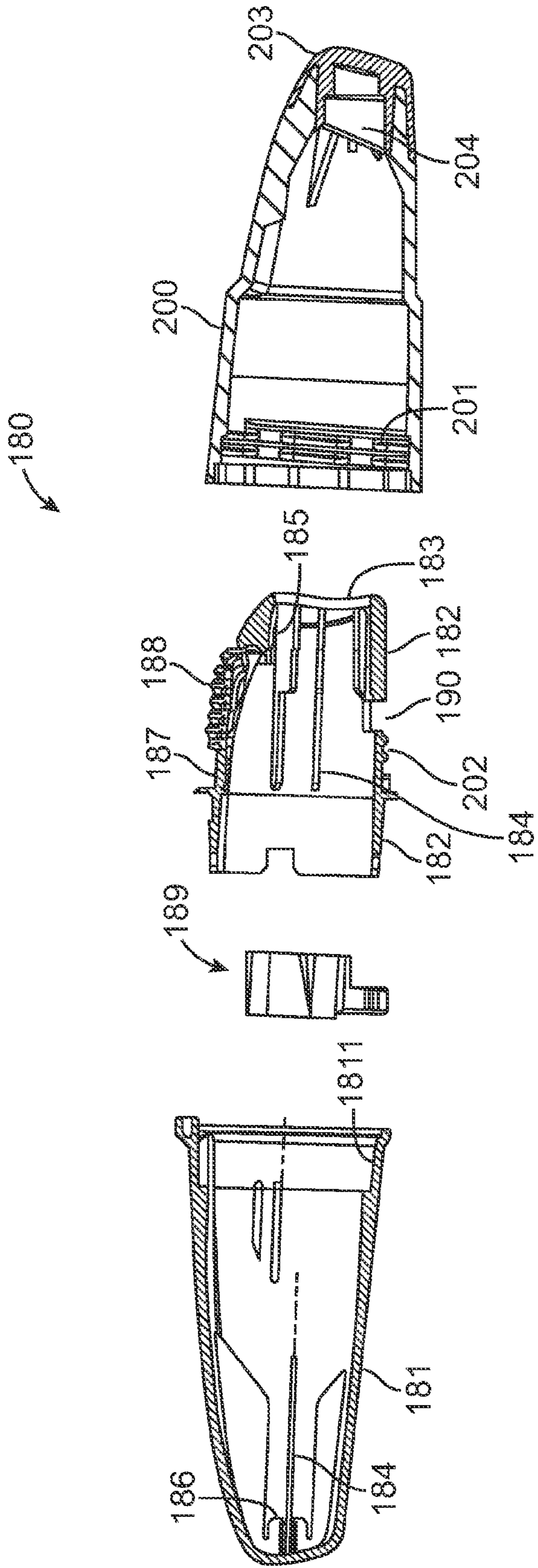

FIG. 18

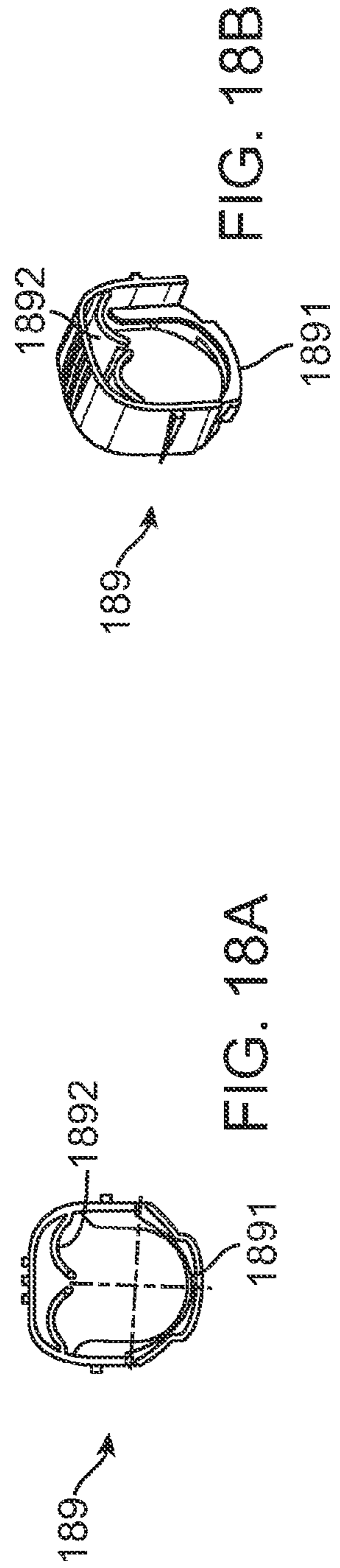

FIG. 18A

FIG. 18B

## 1

## CASING

The present invention relates to injection devices, in particular to needle-less injection devices in which a compressed gas cartridge is used to force a jet of medicament through a patient's skin. Specifically, this invention relates to a casing for such an injection device which interacts with the safety and other mechanisms of such an injection device.

Injection devices generally comprise a number of elements. Generally there is a cartridge of a medicament having a nozzle orifice at one end, out of which in the case of a needle-less injection device the medicament is driven under a pressure sufficient to drive it through a patient's skin. Generally there is a drive means to drive the medicament in this manner, typically comprising a plunger moveable within the cartridge toward the nozzle orifice to drive the medicament, and a means to drive the plunger, such as a spring, commonly comprising a spring means such as compressed gas driving a ram which bears upon the plunger. Generally there is a trigger means operable to cause the drive means to act. Often there is a safety device functioning to prevent the drive means from being inadvertently operated. Such a safety means may function in various ways, for example by obstructing the movement of one or more part of the injection device which is essential for operation of the device, for example functioning by preventing the trigger means from operating. The cartridge of medicament may for example comprise a dose of liquid or powdered medicament to be administered to the patient. Sometimes in a needle-less injection the nozzle orifice of the cartridge is closed prior to use by a break-off tip. Often the drive means, cartridge and orifice lie along an elongate direction which corresponds to the direction along which the plunger moves and the medicament is dispensed.

Needle-less injection devices of various types are described in, inter alia, published International Patent Application Nos. WO-A-93/03779, WO-A-95/03844, WO-A-96/28202 (Weston Medical Limited), U.S. Pat. No. 5,865,795 and US-A-2001/0004681.

Published International Patent Application No. WO-A-97/37705 (Weston Medical Limited), the contents of which are incorporated herein by reference, discloses a needle-less injection device of the general type described above in which compressed gas in a cylinder **130** drives a ram **111** which bears upon a plunger **104** which is moveable within a medicament cartridge **103** to drive medicament content out through orifice **106**. In the device of WO-A-97/37705 operation of the device is prevented by a latch **108** which obstructs the ram **111** and must be moved sideways to allow the ram **111** to move. A trigger means is provided by the device comprising upper **102a** and lower **102b** relatively moveable sleeve portions, and in its pre-firing configuration the sideways movement of the latch **108** being obstructed by the wall of the upper sleeve **102a**. The upper **102a** and lower **102b** sleeves are moved relative to each other by placing the lower sleeve **102b** against the user's skin and urging the upper sleeve downwardly. The relative movement of the upper **102a** and lower **102b** sleeve portions brings an aperture **139** in the wall of the upper sleeve portion **102a** into alignment with the latch **108**, allowing the latch to move sideways into the aperture **139** so that it no longer obstructs the ram. A cam surface **109** on the ram **111** bears on the latch **108** under the force exerted by the compressed gas and forces the latch sideways into the aperture **139**.

In the device of WO-A-97/37705 a safety mechanism is provided by a tear-off band **137** situated between the upper

## 2

**102a** and lower **102b** sleeve portions functioning to obstruct the said relative movement of these sleeve portions until the band **137** has been torn away.

In the device of WO-A-97/37705 the nozzle orifice of the cartridge **103** is closed prior to use by a break-off tip **135** which comprises a seal carrier which carries a seal **134**.

However, various problems may arise from the handling and use of a device such as that of WO-A-97/37705 and similar devices. For instance, the device is fragile and may not be robust enough to be transported by a user in, for instance, a handbag or a pocket. Furthermore, the user may perform the steps required for the actuation of the device in the wrong order. The device of WO-A-97/37705 must be actuated by first snapping off the seal carrier **135** and then removing the tear-off band **137**, before urging the orifice **106** against the user's skin. If the user mistakenly removes the tear-off band **137** before snapping off the seal carrier **135**, it is possible that the action of snapping off the seal carrier may cause the device to be inadvertently actuated. This would result in a wasted dose of the medicament and possibly even delivery of the medicament into the wrong site (e.g. the user's hand).

Also, once the device has been used, the user must dispose of the device and the parts that have been removed, i.e. the seal carrier **135** and the tear-off band **137**, in a safe manner so that the user herself or other people, for instance children, are not endangered by loose parts of the actuated device.

Also, in the device of WO-A-97/37705 there is a risk that a weak user may not be able to apply sufficient force to break the break-off seal **135** at the frangible joint **136**, or the break-off force may be applied unevenly e.g. resulting in inadequate opening of the orifice **106**. Further once the seal carrier **135** has been broken off the user is left in possession of the broken-off carrier **135**, potentially with sharp edges around the frangible joint **136**.

An object of the present invention is to provide a casing in which an injection device, particularly a device such as that of WO-A-97/37705, may be enclosed and which interacts with the device enclosed therein, facilitating the correct operation of the device, and so providing a solution to at least some of the aforementioned problems.

Thus, according to a first aspect the present invention provides a casing for an injection device of the type which comprises a cartridge containing a medicament for injection and having an orifice at one end thereof through which the medicament may be driven for injection through a patient's skin, drive means for driving the medicament through the patient's skin, a trigger means operable to cause the drive means to act, a safety means which in a first configuration prevents the drive means from acting and in a second configuration allows the drive means to act,

wherein

the casing is adapted to enclose the device,

and the casing incorporates an actuator means by which the safety means of an injection device enclosed therein can be brought from its first configuration into its second configuration.

The casing of the present invention facilitates the use of an injection device, in particular in its preferred embodiments by causing the user to operate the injection device according to its pre-determined operating sequence. As secondary advantages the casing can protect the enclosed injection device, improve its aesthetic appearance and improve user compliance by making the injection device appear less intimidating.

Preferably the actuator means may be accessed by a user from outside the casing, so that the user can actuate, i.e. bring

from its first configuration into its second configuration, the safety means of an injection device enclosed therein from outside the casing.

In one form for example, the actuator means may have a part exposed to the outside of the casing and accessible to the user, and to which the user may apply operating force to actuate the safety means.

For example such an actuating means may be constructed to bear upon the safety means and thereby apply actuating force to the safety means to bring it from its first configuration into its second configuration.

Herein the term “bear” and derived terms includes all means by which a force applied to one part is communicated to another part, e.g. by pressing to communicate pressure or pulling to communicate tension.

For example the actuator means may comprise a button, tongue or lever which the user may press inwardly to cause the actuator means to bear upon the safety means and thereby bring the safety means from its first configuration into its second configuration.

For example the actuator means, particularly such a button, tongue or lever, may be resiliently connected to the casing such that on application of actuating force to the actuator means, the actuator means operates against the resilient bias.

For example the actuator means may comprise a means to apply a pulling force to the safety means to pull the safety means from its first configuration into its second configuration. For example such an actuator means may comprise a slider, slideably moveable relative to the casing, a connector means connecting the slider to the safety means whereby the user can move the slider to pull the safety means from its first configuration into its second configuration. For example such an actuator means may comprise a pulley wheel, rotatably moveable relative to the casing, a connector means connecting the pulley wheel to the safety means whereby the user can rotate the pulley wheel to pull the safety means from its first configuration into its second configuration.

For example the actuator means may be constructed so that after it has brought the safety means from its first configuration into its second configuration, the actuator means may give a visible or audible (e.g. a “click”) indication that this has happened. For example the actuator means may remain locked in a visibly deflected position.

Preferably the casing has retaining means to retain the safety means of an enclosed device in its second configuration after the safety means has been brought from its first configuration into its second configuration.

In another form, for example the actuator means may comprise a window in the casing through which the safety means may be actuated. For example such a window may be so shaped and positioned that a user may be able to reach the safety means of an injection device enclosed therein, or so that a part of or connected to the safety means of an injection device enclosed therein may extend through the window to be accessed and operated by the user from outside of the casing. Such a part may comprise a pull handle or “ripcord” means which may be pulled from outside of the casing to move the safety means from its first configuration into its second configuration.

By “enclosed” is included partial or complete enclosure. As injection devices are generally elongate and cylindrical the casing of the invention will normally be of a generally corresponding shape, e.g. a cylinder or ellipsoid in outer shape. Preferably the casing is adapted to enclose at least the cartridge, the drive means, the trigger means and the safety means of the injection device. Preferably the casing has an opening, which may be removably covered prior to use, by

which the orifice through which the medicament may be driven for injection through a patient’s skin can be brought adjacent to the patient’s skin. In an elongate casing such an opening may be an end opening.

Preferably the casing is adapted to enclose the injection device by being internally shaped to generally conform to the external shape of the device, and/or by the provision of internal supports able to securely hold an injection device enclosed therein. The design of these will depend upon the shape and construction of the injection device to be enclosed. If the casing is to hold a device such as that of WO-A-9737705 which is triggered by being pressed against a user’s skin, it is important that the casing is constructed such that pressure applied to the casing to press the device against the user’s skin is communicated to the injection device, and such supports may be used to achieve this.

The casing comprises a container for the injection device. The casing may be of single part construction or of multi-part construction for example comprising two or more casing sub-parts which fit together by for example a screw, friction or snap-fit to securely enclose and retain an injection device therein.

A second aspect of the present invention provides a combination of a casing as described above according to the first aspect,

and enclosed within the casing an injection device of the type which comprises:

a cartridge containing a medicament for injection and having an orifice at one end thereof through which the medicament may be driven for injection through a patient’s skin, drive means for driving the medicament through the patient’s skin, a trigger means operable to cause the drive means to act, a safety means which in a first configuration prevents the drive means from acting and in a second configuration allows the drive means to act.

Such a combination comprises:

an injection device of the type which comprises a cartridge containing a medicament for injection and having an orifice at one end thereof through which the medicament may be driven for injection through a patient’s skin, drive means for driving the medicament through the patient’s skin, a trigger means operable to cause the drive means to act, a safety means which in a first configuration prevents the drive means from acting and in a second configuration allows the drive means to act;

a casing enclosing the injection device,

wherein the casing incorporates an actuator means by which the safety means of the injection device enclosed therein can be brought from its first configuration into its second configuration.

The combination of the casing with the injection device already enclosed therein may be provided to a user e.g. a prescription patient, as a unit.

Preferably in its first configuration the safety means prevents the drive means from acting by preventing the trigger means from operating, for example by obstructing the movement of a moveable trigger part, and in its second configuration allows the trigger means to operate.

Therefore preferably the safety means comprises an obstructer part which in the first configuration obstructs, and in the second configuration allows, the movement of a moveable trigger part.

Such a safety means may be moveable, e.g. by displacement and/or deformation, by using the actuator means, from its first configuration to its second configuration, e.g. the actuating means may bear upon the safety means and thereby apply actuating force to the safety means to move it e.g. by displacement and/or deformation.

5

When the casing is elongate, preferably a moveable safety means comprises an obstructer part which is brought from its first configuration to its second configuration by a movement of the obstructer part e.g. by displacement or deformation, or the entire safety means, in a direction perpendicular to the elongate direction.

For example a moveable safety means may comprise a collar (the term includes a part-collar) shaped to at least partly surround the injection device, and moveable from its first configuration into its second configuration in a direction generally perpendicular to the direction in which the medicament is dispensed, the collar incorporating an obstructer part.

Preferably the safety means, or at least the obstructer part, is biased to be retained in its first configuration and is movable against this bias into its second configuration.

For example a moveable safety means may comprise a removable obstructer part, e.g. a tear-off band functioning as an obstructer part as disclosed in WO-A-97/37750, and such a band may have an extension which is accessible from outside of the casing, e.g. through a window in the casing, which a user may grip and pull to remove the obstructer part from the injection device and from the casing.

Alternatively the safety means may be broken or destroyed in its second configuration, e.g. the actuating means may bear upon the safety means and thereby apply actuating force to the safety means to break or destroy it.

Preferably the injection device is as disclosed in WO-A-97/37705 the content of which is incorporated herein by reference.

Therefore preferably the trigger means, as in WO-A-97/37705, is provided by two relatively moveable upper and lower sleeve parts which on relative movement allow the drive means to act.

When the injection device comprises a device in which the trigger means comprises two relatively moveable upper and lower sleeve parts which on relative movement allow the drive means to act, the safety means may comprise an obstructer part which in its first configuration obstructs, and in its second configuration allows, the relative movement of these sleeve parts.

For example with such a device preferably the safety means comprises an obstructer part which is brought from its first configuration to its second configuration by a movement of the obstructer part in a direction perpendicular to the direction of relative movement of these two sleeves, this direction suitably being perpendicular to the elongate direction of the device and the casing, being also generally perpendicular to the dispensing direction of the medicament.

For example when the injection device comprises a device in which the trigger means comprises two relatively moveable upper and lower sleeve parts which on relative movement allow the drive means to act, as in the device of WO-A-97/37705, such a moveable safety means may comprise a collar shaped to at least partly surround the injection device, and moveable from its first configuration into its second configuration in a direction perpendicular to the direction of relative movement of these two sleeves, the collar incorporating an obstructer part which in the first configuration is situated between the two sleeves to obstruct the relative movement, and in the second configuration is displaced in a direction perpendicular to the direction of relative movement of these two sleeves to thereby allow the relative movement of these sleeves.

Such a collar may surround that part of the injection device which is longitudinally between the two sleeves. Such a collar may be resiliently biased into its first configuration, for

6

example by spring parts bearing upon the injection device or upon the casing, so that movement into the second configuration is against this bias.

Preferably the safety means, e.g. a collar as described above, has retaining means by which it may be retained in its second configuration after the safety means has been actuated. Such retaining means may interact, e.g. lock with, corresponding retaining means on the casing or the injection device. The operation of such retaining means may be accompanied by a visible or audible indication thereof.

Alternatively the safety means may require a continuous actuation of the actuator means to retain the safety means in its second configuration.

Such a safety means, e.g. the above described collar, may be integrally made of resilient plastics materials.

A third aspect of the present invention provides a casing adapted to enclose a container of a medicament of the type having an opening at one end through which the medicament may be accessed for dispensing and the opening being closed prior to use by a break-off tip,

the casing comprising relatively moveable first and second casing parts, being a first casing part adapted to hold the container, and a second part adapted to bear upon the break-off tip of a container held by the first casing part as a result of such relative motion to apply a force thereto causing the break-off tip to break off from the container.

Preferably the container is an injection device of the type comprising a cartridge having its injection nozzle orifice closed prior to use by a break-off tip, and the casing comprises a container for the device.

The invention also provides a combination of such a casing and an injection device enclosed therein.

Such a combination comprises:  
a casing enclosing an injection device of the type comprising a cartridge having its injection nozzle orifice closed prior to use by a break-off tip,

the casing comprising relatively moveable first and second casing parts, being a first casing part adapted to hold the injection device, and a second part adapted to bear upon the break-off tip as a result of such relative motion to apply a force thereto causing the break-off tip to break off from the injection device.

In one embodiment the first casing part may be elongated along a longitudinal axis, the first casing part may be adapted to hold the container non-rotatably relative thereto, e.g. by internal supports and the second part can be moved in rotary motion relative to the first part so as to bear on the break-off tip of a container held by the first casing part, and to apply a twisting shearing force to the frangible joint between the break-off tip and the container.

Such rotary relative motion may be about a rotation axis coaxial with this longitudinal axis, about a rotation axis parallel to but non-coaxial with this longitudinal axis, or about a rotation axis at a non-zero angle to the longitudinal axis. The latter two modes of rotary motion may be advantageous in applying a shearing force to the frangible joint.

For example such rotation may be achieved by means of the first and second casing parts being initially connected together by a screw thread or bayonet connection, so that un-connecting the connection applies a shear force to break off the tip of a container held by the first casing part, and also separates the first and second casing parts to hereby expose the opening for use.

Alternatively such rotary relative motion may be about a rotation axis transverse to e.g. preferably perpendicular to this longitudinal axis so as to snap the frangible joint. For example such rotation may be achieved by the second casing

part being pivotally mounted on the first casing part, with a pivot axis perpendicular to the longitudinal axis. Alternatively the second casing part may be hinged to the first casing part about a hinge axis, such that as the second casing part moves in rotary hinged motion about this hinge axis relative to the first casing part the second casing part bears upon the break-off tip.

Alternatively the second casing part may incorporate a bearing part moveable relative to the second casing part and first casing part, e.g. operable by a button or lever etc. of the second casing part, to thereby bear upon the break off tip.

The second casing part may have internal parts to hold or support the break off tip, and/or which bear on the break off tip during the relative motion. The second casing part may be internally provided with gripping means to assist the second casing part in bearing on the break-off tip of a container held by the first casing part, and applying the shearing force. The design of these will depend upon the shape and construction of the injection device to be enclosed.

For example the second casing part may incorporate a cup part having internal surfaces of a rubbery material with a high coefficient of friction relative to the break-off tip.

In a preferred embodiment the casing of this third aspect of the invention is a casing of the first aspect of the invention, which may be used in a combination as in the second aspect of this invention, and the first casing part is adapted to hold an injection device wherein the cartridge has an opening at one end through which the medicament may be dispensed and the opening is closed prior to use by the break-off tip.

This preferred embodiment of the invention therefore comprises;

a casing for an injection device of the type which comprises a cartridge containing a medicament for injection and having an orifice at one end thereof through which the medicament may be driven for injection through a patient's skin, drive means for driving the medicament through the patient's skin, a trigger means operable to cause the drive means to act, a safety means which in a first configuration prevents the drive means from acting and in a second configuration allows the drive means to act, and having its injection nozzle orifice closed prior to use by a break-off tip, wherein:

the casing is adapted to enclose the device,

and the casing incorporates an actuator means by which the safety means of an injection device enclosed therein can be brought from its first configuration into its second configuration, and,

the casing comprises relatively moveable first and second casing parts, being a first casing part adapted to hold the injection device, and a second part adapted to bear upon the break-off tip as a result of such relative motion to apply a force thereto causing the break-off tip to break off from an injection device enclosed within the casing.

Preferably for use with such an injection device the first casing part may be elongated in the longitudinal direction along which the plunger moves to drive the medicament through the orifice.

Preferably when the first casing part is adapted to hold an injection device the first casing part has an opening by which the orifice through which the medicament may be driven for injection through a patient's skin can be brought adjacent to the patient's skin, and this opening may be an end opening of an elongate first casing part, and the second casing part comprises a removable cover for this end opening, e.g. in the form of an end cap.

In this preferred embodiment, the casing may be constructed so that the actuator means cannot be operated before the second casing part has been moved relative to the first

casing part in the manner described above. This can ensure that an injection device contained therein is operated in the correct operating sequence, i.e. the break-off tip is first broken off and only thereafter the drive means can be caused to operate.

For example the second casing part may comprise a cover part over the actuator means which prevents operation of the actuator means until the cover part is removed. For example the second casing part may comprise a cap, covering the actuator, with a screw thread connection to the first casing part and the action of unscrewing such a cap may both break off the break-off tip and expose the actuator for use.

Alternatively the second casing part may incorporate a locking means to lock the actuator means until the second casing part has been removed.

Alternatively the second casing part may comprise the actuator means, so that the movement of the second casing part relative to the first casing part causes the safety means of an injection device enclosed within the casing to move from its first configuration to its second configuration. For example the second casing part may comprise a bearing part which bears upon the safety means, e.g. by pressure or pulling analogous to the description above, to move the safety means from its first configuration to its second configuration.

For example the second casing part may itself comprise a safety means. For example the second casing means may incorporate at least one obstructer part which functions to obstruct movement of a part of the injection device which is essential for operation, and which is moved from a first configuration to a second configuration by the relative movement of the second casing part.

The casing of all aspects of the invention, and the safety means such as a collar, may conveniently be made of plastics materials by for example injection moulding.

The invention also provides a combination of such a casing and an injection device enclosed therein.

Preferred features of such a casing, and its combination with an injection device, are as described above.

The construction and operation of a device according to this invention will now be described by way of example only with reference to the following Figures.

FIGS. 1-4 show schematically the operation of a known type of needle-less injection device.

FIGS. 5-8 show schematically the construction of a casing of this invention and its operation with a device as shown in FIGS. 1-4.

FIG. 9 shows the construction and operation of the safety means as used in the casing of FIGS. 1 to 8.

FIGS. 10 and 11 show schematically the construction of another casing of this invention and its operation with a device as shown in FIGS. 1-4.

FIGS. 12 and 13 show schematically the construction of another casing of this invention and its operation with a device as shown in FIGS. 1-4.

FIGS. 14 and 15 show schematically the construction of another casing of this invention and its operation with a device as shown in FIGS. 1-4.

FIGS. 16 and 17 show schematically the construction of another casing of this invention and its operation with a device as shown in FIGS. 1-4.

FIG. 18 shows a casing of this invention, in multi-part construction.

Referring to FIGS. 1-4 the operation of the device 10 disclosed in WO-A-97/37705 is illustrated schematically, the numbering scheme of WO-A-97/37705 being followed in these drawings. The device 10 comprises an upper sleeve part 102a and a lower sleeve part 102b which are relatively move-

able toward each other. At the lower end of the device is a break-off tip **135** which can be broken off at frangible joint **136** as described in WO-A-97/37705 to open a nozzle orifice **106**. The action of moving the sleeve parts **102a**, **102b** in the way described triggers the latch mechanism (108 in WO-A-97/37705, not shown in FIGS. 1-4) and causes compressed gas in cylinder **130** to operate an internal ram (111 in WO-A-97/37705, not shown in FIGS. 1-4) which drives medicament content **105** in cartridge **103** out through orifice **106**. However prior to use the relative movement of sleeve parts **102a** and **102b** is obstructed by tear-off band **137**, being a safety means.

The operation of the device is shown sequentially through FIGS. 1-4. FIG. 1 shows the pre-use configuration with band **137** in place. In FIG. 2 the break-off tip **135** has been broken off at frangible joint **136**, exposing orifice **106**. In FIG. 3 the tear off band **137** has been torn off so that relative movement of sleeve parts **102a**, **102b** is no longer obstructed. In FIG. 4 the orifice **106** has been placed against the skin **11** of the user and pressure has been applied to the cylinder **130** to force sleeve part **102a** downwardly relative to sleeve part **102b**. As described in WO-A-97/37705 this has "fired" the device and caused the medicament **105** to be injected through the user's skin **11**.

Referring to FIGS. 5-9 a casing **50** of this invention is shown in a longitudinal sectional view. The casing **50** encloses a device **10** as shown in FIGS. 1-4. The device **10** is an elongate device, the direction of its longitudinal axis being shown by a dashed line. This direction is also the direction along which the sleeve parts **102a**, **102b** move relative to each other, and the direction in which medicament content is ejected from the orifice **105**.

The casing **50** is generally ellipsoidal elongate in a direction parallel to the longitudinal axis of the device **10** and comprises a first casing part **51** and a second casing part **52**. The first casing part **51** and second casing part **52** are joined at a screw thread connection **53**. Each casing part **51,52** may itself comprise sub-assemblies fitted together. The casing parts **51,52** are made of plastics material by injection moulding.

Within first casing part **51** the device **10** is supported and held securely by internal supports, bulkheads etc. (not shown but the construction of which will be apparent to those skilled in the art). In particular the device **10** is held within first casing part **51** such that device **10** is non-rotatable relative to part **51** about an axis parallel to the long axis of casing **51,52**.

The tear-off band **137** shown in FIGS. 1-4 is not present on the device **10**. In its place is a safety means **54** comprising a collar which fits around the cartridge **103** and the sleeve parts **102a,102b**. The construction of part **54** is shown in more detail in FIG. 9. As seen in FIG. 9A being a cross section through the collar **54** and device **10** at line A-A in FIG. 1, and FIG. 9B being a longitudinal part sectional view through the collar **54** and immediately adjacent part of device **10**, at right angles to the line A-A of FIG. 9A, the part **54** comprises a collar **541** of cross sectional dimensions greater than that of sleeve parts **102a** and **102b**, which surrounds cartridge **103** and the immediately adjacent parts of sleeve parts **102a,102b**. The part **54** has an obstructer part **542** being a block which when the part **54** is in place around the cartridge **103** as shown in FIG. 5 obstructs any relative longitudinal movement of sleeves **102a** and **102b**, by fitting longitudinally between them and blocking their relative movement. The collar **541** is supported in this configuration by resilient spring leaves **543, 544** which bear on the sleeve parts **102a,102b**. This is the first configuration of part **54**.

Referring to FIG. 6 the second casing part **52** has been rotated relative to first casing part **51** about the axis of rotation

R, thereby unscrewing second casing part **52** from first casing part **51** at screw connection **53** and disconnecting parts **51** and **52**. Second casing part **52** has internal parts e.g. internal supports, walls etc. (not shown but the construction of which will be apparent), which bear upon the break-off tip **135**. Axis R is parallel to but not co-axial with the longitudinal axis of the part **10**, a shearing force is applied to the frangible joint **137**, which consequently breaks. The device **10** is now in a configuration corresponding to FIG. 2.

Referring to FIG. 7 an actuator means is provided by a resilient tongue **55**, integral with first casing part **51**, and which can be inwardly deflected by pressure on an operating button **56**. This inward deflection causes means **55** to bear upon the upper surface (as seen in FIG. 9) of the collar **541**, and the collar **541** to be consequently moved downwardly against the resilience of springs **543**, and the obstructer part **542** to be consequently moved into a position in which it does not obstruct the relative movement of sleeve parts **102a** and **102b**. This is shown more clearly in FIG. 9C, being the second configuration of part **54**. When in this second configuration the first casing part **51** and part **54** may have co-operating means, e.g. snap fit detent means, so that part **54** is retained in this second configuration independently of pressure applied by part **55**. Alternatively, e.g. as a further safety feature, the casing may be constructed so that continued pressure on part **55** is necessary to hold part **54** in this second configuration. The device **10** is now in a configuration corresponding to FIG. 2.

Also as shown in FIGS. 5 and 6, the second casing part **52** integrally incorporates a cover part **57** comprising a cover flap which covers the actuator button **56** when the second casing part is attached by the screw thread **53** to first casing part **51**. This prevents the actuator part **56** from being actuated in the manner shown in FIG. 7 until the second casing part **52** has been unscrewed from first casing part **51** and removed in the downward direction as shown, with the consequence of breaking off the break off tip **135**, and thereby causes the user to operate the device **10** in the proper operating sequence as described with reference to FIGS. 1-4.

Referring to FIG. 8, the orifice **106** has been placed against the skin **11** of the user and pressure has been applied to the first casing part **51** in the direction toward the skin **11**. This pressure is communicated to the injection device **10** to force sleeve part **102a** downwardly relative to sleeve part **102b**. In a manner corresponding to FIG. 4 this has caused the device **10** to "fire" and to inject medicament **105** through the user's skin **11**.

Referring to FIG. 10, another casing **110** of this invention is shown in a side view. The casing **100** incorporates a device **10** as with the casing of FIGS. 1-9. The casing **100** comprises first casing part **111** and second casing part **112**. The internal construction of the first casing part **111** is analogous to that of first casing part **51**, i.e. incorporating a safety means **54** and an actuating means **55, 56** as therein.

FIG. 11 shows a plan view of the casing **110** illustrating more clearly the construction of the part **55** and **56**, which is analogous to those of FIGS. 1-8.

In the casing **110** the second casing part **112** is mounted on two opposite pivot axles **113**, so that part **112** can rotate about the axis between these axles **113**, this axis of rotation being perpendicular to the longitudinal axis of the device **10** and of the elongated casing **110**, so that part **112** swings in rotation relative to part **111** and follows the arc shown in FIG. 10, to swing into the position shown in FIG. 11A. As the casing part **112** rotates in this way its internal parts (not shown), such as internal ribs or a cup-shaped holder to hold the break-off tip **135**, bear upon the break-off tip **135** and cause the frangible



## 11

joint 137 to shear analogously to FIGS. 2 and 6. As the part 112 continues to rotate along this arc, it carries the broken off tip 135 away from orifice 106. The casing parts 111, 112 may have respective co-operating locking means (not shown) by which the part 112 may be initially releasably locked in place in its non-rotated configuration as shown in FIG. 10 before being unlocked to allow the casing part 112 to swing through the arc. Such a locking means may help to prevent accidental break-off of the break off tip 135.

The actuator part 55 can then be operated in a manner analogous to the casing of FIGS. 5-9 to render the device 10 ready to trigger and operate.

The orifice 106 can then be placed against the user's skin 11 in a manner analogous to FIG. 8 and pressure can be applied to the first casing part 51 to force sleeve part 102a downwardly relative to sleeve part 102b causing the device 10 to "fire" as in FIGS. 4 and 8 to inject medicament 105 through the user's skin 11.

In the device of FIGS. 10 and 11 it is of course important that the arc which the second casing part 112 follows allows sufficient of the device 10 to project beyond the lower end as shown of the casing part 111 to allow the orifice 106 to be placed adjacent to the user's skin. This can be arranged by a suitable geometry of the casing 110 to give the second casing part 112 sufficient clearance of the orifice 106 as the part 112 swings in its arc. The second casing part 112 may also be constructed so that a downward (as shown) movement of the second casing part 112 is necessary before the second casing part 112 can pivot in the manner shown. This can be achieved for example by means of a "keyhole" shaped pivot socket which engages with an elongate section stub axle which can only rotate when the axle has been moved longitudinally into the wide part of the "keyhole". This can help to provide the clearance between the second casing part 112 and the orifice 106.

The dimensions of the casing parts 111 and 112 may be such that the second casing part 112 may rotate through 180° from the position shown in FIGS. 10 and 11 so that it can conveniently be "stowed" at the opposite end of the first casing part 110 to that from which the orifice 106 projects.

It will be apparent that the casing 51, 52, 101, 102 facilitates the operation of the device 10, and as seen in FIG. 11 can enhance the outward appearance of the casing.

Referring to FIGS. 12 and 13 another casing 120 is shown in schematic longitudinal section. The casing 120 is similar in construction to that of FIGS. 5-8, having a first casing part 121, and a second casing part (not shown) which is identical to that 52 of FIGS. 5-8 and which is initially connected to casing part 121 by a screw thread in an analogous manner. In FIG. 12 the casing 120 is shown with this second casing part removed, i.e. in a configuration analogous to FIG. 7.

The casing 120 incorporates a device 10 as shown in FIGS. 1-4. The device 10 has a safety means being a tear-off band 137 analogous to that shown in FIGS. 1 and 2. The band 137 has an extension 122 which extends through a window aperture 123 in first casing part 121 to the outside of casing part 121. The extension 122 may be gripped by a user and pulled from outside the casing to thereby remove the band 137 as seen in FIG. 13. The casing 120 is then in a configuration analogous to FIG. 7 and may be used in a manner analogous to FIG. 8. It will be appreciated that band 137 in FIG. 12 may be replaced by other forms of removable obstructer means. As in FIGS. 5-8 a cover part such as that 57 may cover the extension 122 until the second casing part has been removed.

Referring to FIGS. 14 and 15, these illustrate casings 140, 150 similar in general concept to FIGS. 12 and 13, and corresponding parts are numbered correspondingly, but in which

## 12

the actuator means may comprise a means to apply a pulling force to the safety means to pull the safety means from its first configuration into its second configuration.

In FIG. 14 the actuator means 141 comprises a slider 141 e.g. in the form of a slider button, easy for the user to access and use, slideably moveable relative to the casing 140. For example the slider may be mounted in a slide groove or track (not shown) in the wall of the casing 140. The slider 141 is connected e.g. integrally to a connector means 142 connecting the slider 141 to the safety means 137. The user can move the slider 141 to pull the safety means 137, and this can cause the safety means to be pulled from its first configuration (as shown in FIG. 14) into its second configuration e.g. analogous to FIG. 13. For example the safety means 137 may comprise a plastics material strip which can be unwound from its position around the device 10.

In FIG. 15 the actuator means 151 comprises a pulley wheel 151, rotatably moveable e.g. by being mounted on an axle (not shown) relative to the casing 150 and which can easily be rotated by the user, e.g. by a thumb operation. There is a connector means 152 connecting the pulley wheel 151, e.g. an integral construction, to the safety means 137 whereby the user can rotate the pulley wheel 151 to pull the safety means from its first configuration (as shown in FIG. 15) into its second configuration e.g. analogous to FIGS. 1-4.

Referring to FIGS. 16 and 17, these illustrate casings similar in concept to FIGS. 10-11 and FIGS. 5-8, corresponding parts of which are numbered correspondingly, but in which the second casing part 112, 52 comprises the actuator means 161, 171, so that the movement of the second casing part 112, 52 relative to the first casing part 111, 51 causes the safety means 162, 171 of an injection device 10 enclosed within the casing 160, 170 to move from its first configuration to its second configuration.

In FIG. 16 the second casing part 163 comprises a bearing part 161 in the form of a plastics connector strip 161 which may be integrally made with the tear-off band 162 which comprises a safety means analogous in operation to that 137 of FIG. 12. When the second casing part 163 is rotated to unscrew casing part 163 from first casing part 51, the bearing part 161 bears upon the safety means 162 by pulling the safety means 162 and unwinding safety means 162 from the device 10 enclosed therein, as shown in FIG. 16A. Consequently the break-off tip 135 is first broken off as second casing part rotates, then the safety means 162 functions to allow the trigger of the device 10 to operate in a manner analogous to that above.

In FIG. 17 the second casing part 172 itself comprise a safety means. The second casing part 172 incorporates at least one obstructer part 171, projecting inwardly toward the device 10 enclosed therein. In its first configuration as shown in FIG. 17 the obstructer part 171 functions to obstruct relative movement of the trigger parts 102a, 102b of the device 10 as shown in FIGS. 1-4. As second casing part 172 swings in an arc about the pivot axis 113, the second casing part 172 firstly breaks off the break-off tip in a manner analogous to FIGS. 10 and 11, and then as second casing part 172 swings to expose the orifice 106 of the device 10 as shown in FIG. 17A, the obstructer part 171 moves out of its obstructing position between the two trigger parts 102a, 102b. The first casing part 170 may be made with suitable clearances etc. to allow the movement of the obstructer part 171.

Referring to FIG. 18, a casing 180 is shown in a dissembled view. The casing 180 is generally similar in construction and operation to that shown in FIGS. 5-8 as will be apparent.

Referring to FIG. 18 a casing 180 of this invention is shown in a longitudinal sectional view. The casing 180 is of multi-

part construction for example comprising a first casing sub-part **181** and a second casing sub-part **182** which fit together by a tight friction or snap-fit fit of plug part **1821** of part **182** into a closely conforming socket part **1811** of part **181**. When fitted together the parts **181** and **182** define an elongate casing which can enclose an injection device (not shown) of the general type **10** described above, with its break-off tip **123** projecting through an end opening **183** of part **182**. The casing sub-parts **181**, **182** are shaped internally and are provided with internal support ribs **184** to hold the device **10** non-rotatably within the assembled casing **181,182**. Internally the part **182** has a conical interior at **185**. The device **10** has a corresponding conical outer profile which can abut against this internal conical profile **185**, and there is also an end support **186** against which a device **10** within the casing assembly **181,182** can abut, and these features prevent longitudinal movement of the device **10**.

Casing sub-part **182** incorporates an actuator means **187**, **188** similar in construction to that **56**, **57** of FIG. **5-8**. The actuator means comprises a resilient tongue **187**, integral with sub-part **182**, and which can be inwardly deflected by pressure on an operating button **188**.

Located within sub-part **182** is a collar **189**, similar in overall construction to that described with reference to FIG. **9**. Collar **189** is shown in a longitudinal view in FIG. **18A** and in perspective view in FIG. **19B**. Corresponding to FIG. **9** the collar **189** comprises an obstructer part **1891** and resilient spring leaves **1892**. The operation of the collar **189** under the action of the actuator means **187,188** is analogous to collar **541** of FIG. **9**. However as an additional feature the sub-part **182** is provided with a cut out **190** into which the obstructer part **1891** may fit when the collar **189** is displaced in the downward direction as seen, so that the obstructer part **1891** can be seen therein as a confirmation that the device has been properly operated.

The casing assembly **181,182** comprises a first casing part. The casing **180** also has a second casing part **200**, in the form of a generally rounded conical cover into which the sub-part **182** fits and engages by means of co-operating screw threads **201**, **202**. The casing part **200** has a nose cone **203** which is made of a high-friction elastomer material which can grip the break-off tip **135** of a device **10** enclosed in first casing **181**, **182**, the nose cone **203** being shaped internally concave so that the break off tip **135** can comfortably fit into the conforming concavity **204**.

In a construction and operation analogous to FIGS. **5** and **6**, the second casing part **200** can be rotated relative to first casing part **181,182**, about an axis of rotation thereby unscrewing second casing part **200** from first casing sub-part **182** at screw connection **201,202**, thereby disconnecting parts **181,182** and **200**. Second casing part **200** is constructed such that the concavity **204** is not concentric with the axis of rotation, so that as second casing part **200** rotates about this axis the nose cone **203** is displaced transverse to the rotation axis and bears upon the break-off tip **135**. A shearing force is consequently applied to the frangible joint **137**, which consequently breaks, in a manner analogous to FIG. **6**.

The second casing part **200** is also constructed so that as it fits over sub-part **182**, casing part **200** covers actuator means **187,188** so that the actuator means **187,188** is shield from being actuated until casing part **200** has been unscrewed and removed, thereby first breaking off the break-off tip **135** and therefore causing device **10** to be operated in the correct operating sequence.

The invention claimed is:

1. A needle free injector, comprising
  - a cartridge containing a medicament for injection and having an orifice at one end thereof
  - a drive mechanism for driving the medicament out of the cartridge via an exit orifice and through skin of a patient;
  - a trigger mechanism which on actuation releases the drive mechanism;
  - a safety mechanism, which in a first configuration prevents the drive mechanism from being actuated and in a second configuration allows the drive mechanism to be actuated;
  - wherein the safety mechanism operates by obstructing movement of a moveable trigger component; and
  - further comprising:
    - a first casing part; and
    - a second casing part;
    - wherein the second casing part comprises a removable end cap which closes a nozzle orifice prior to removal of the removable end cap;
    - wherein the needle-free injector is configured such that the drive mechanism cannot be operated before the second casing part has been removed from an end opening of the first casing part.
2. The needle free injector of claim 1, wherein the moveable trigger mechanism is moved by urging the orifice against the patient's skin.
3. The needle free injector of claim 2:
  - wherein the first casing part forms a cover around the needle free injector.
4. The needle free injector of claim 3, wherein the first casing part comprises an end opening positioned such that the orifice through which the medicament is driven can be brought adjacent to the patient's skin.
5. The needle free injector of claim 4, wherein the second casing part comprises a removable cover for the first casing part end opening.
6. The needle free injector of claim 5, wherein the first casing part is adapted hold the needle free injector non rotatably relative thereto, and the second casing part is rotatable relative to the first casing part.
7. The needle free injector of claim 6, wherein the first and second casing parts are initially connected together by a connector selected from the group consisting of:
  - a screw thread; and
  - a bayonet connection;
  - further wherein moving the second casing part in a rotary motion separates the first and second casing parts to thereby expose the end opening for use.
8. The needle free injector of claim 7, wherein the safety mechanism is configured to prevent inadvertent actuation of the trigger while removing the second casing part.
9. The needle free injector of claim 8, wherein the safety mechanism is a locking mechanism incorporated in the second casing part.
10. The needle free injector of claim 8, wherein the second casing part comprises an actuator mechanism, wherein the movement of the second casing part relative to the first casing part causes the safety mechanism to move from its first configuration to its second configuration.
11. The needle free injector of claim 9, wherein the second casing part incorporates at least one obstructer part which functions to obstruct movement of a part of the injection device which is essential for operation.
12. The needle free injector of claim 9, wherein the safety mechanism comprises an actuator, said actuator further comprising an obstructer part which in a first configuration

**15**

obstructs, and in a second configuration allows, the movement of the moveable trigger part.

**13.** The needle free injector of claim **12**, wherein the actuator is configured in a form selected from the group consisting of:

- a button;
- a tongue; and
- a lever.

**14.** The needle free injector of claim **13**, wherein the end cap is configured to cover part of the actuator and the action of unscrewing the cap exposes the actuator for use.

**15.** The needle free injector of claim **14**, wherein the actuator is a lever.

**16**

**16.** The needle free injector of claim **15**, wherein movement of the lever moves the obstructer part in a direction perpendicular to the direction of relative movement of the trigger part when the orifice is urged against the patient's skin.

5 **17.** The needle free injector of claim **16**, wherein the actuator is retained in its second configuration after the safety mechanism has been actuated.

**18.** The needle free injector of claim **17**, wherein the actuator being retained is accompanied by an indication selected from the group consisting of a visible indication and audible indication.

\* \* \* \* \*