

US008186881B2

(12) **United States Patent**
Lyon et al.

(10) **Patent No.:** **US 8,186,881 B2**
(45) **Date of Patent:** **May 29, 2012**

(54) **RESERVOIR CLOSURE SYSTEM AND METHOD**

(75) Inventors: **Matthew J. Lyon**, Moraga, CA (US);
Samuel M. Lopez, San Francisco, CA (US)

(73) Assignee: **Hydrapak, Inc.**, Oakland, CA (US)

(*) Notice: Subject to any disclaimer, the term of this patent is extended or adjusted under 35 U.S.C. 154(b) by 0 days.

(21) Appl. No.: **13/237,165**

(22) Filed: **Sep. 20, 2011**

(65) **Prior Publication Data**

US 2012/0008883 A1 Jan. 12, 2012

Related U.S. Application Data

(63) Continuation of application No. 11/445,721, filed on Jun. 2, 2006, now Pat. No. 8,043,005.

(51) **Int. Cl.**

B65D 33/16 (2006.01)
B65D 33/30 (2006.01)
A22C 15/00 (2006.01)
A43C 11/12 (2006.01)

(52) **U.S. Cl.** **383/69**; 383/89; 383/90; 24/30.5 L; 24/437

(58) **Field of Classification Search** 383/68, 383/69, 89, 90; 24/30.5 L, 437
See application file for complete search history.

(56) **References Cited**

U.S. PATENT DOCUMENTS

1,219,232 A * 3/1917 Blumberg 383/22
1,371,934 A 3/1921 Reynolds

1,781,448 A	11/1930	Dunnican	
2,021,609 A *	11/1935	Pippert 383/69
2,064,432 A	12/1936	Keidel	
2,500,363 A	3/1950	Koeppel	
2,514,750 A	7/1950	Dobbs et al.	
3,026,017 A	3/1962	Hopkins	
3,173,184 A	3/1965	Ausnit	
3,381,883 A	5/1968	Harris	
3,437,117 A	4/1969	Vitello et al.	
3,738,790 A	6/1973	Violette et al.	
4,099,656 A	7/1978	Neumann et al.	
4,541,117 A	9/1985	Ashbeck	
4,660,259 A	4/1987	Ausnit	
4,883,329 A	11/1989	Flannery et al.	
4,979,663 A	12/1990	Sofia et al.	
4,979,668 A	12/1990	Allen et al.	
5,116,139 A	5/1992	Young et al.	
5,211,482 A	5/1993	Tilman	
5,354,132 A	10/1994	Young et al.	
5,435,648 A	7/1995	Berkoff	
5,462,222 A	10/1995	Boeck	
5,765,264 A	6/1998	Ciok	
5,947,524 A	9/1999	Podosek	
6,059,456 A	5/2000	May	

(Continued)

FOREIGN PATENT DOCUMENTS

FR 74516 12/1960

(Continued)

Primary Examiner — Jes F Pascua

(74) *Attorney, Agent, or Firm* — Levine Bagade Han LLP

(57) **ABSTRACT**

A system for sealably closing a reservoir is disclosed. The system can have a container and a slider. The container can have an orifice and catches and lips surrounding the orifice. The slider can be translatably attached to the container over the orifice. The slider can slidably engage the catch and lips to force the orifice closed. While attached to the catch and lips, the slider can create a pressurized seal of the orifice.

16 Claims, 15 Drawing Sheets

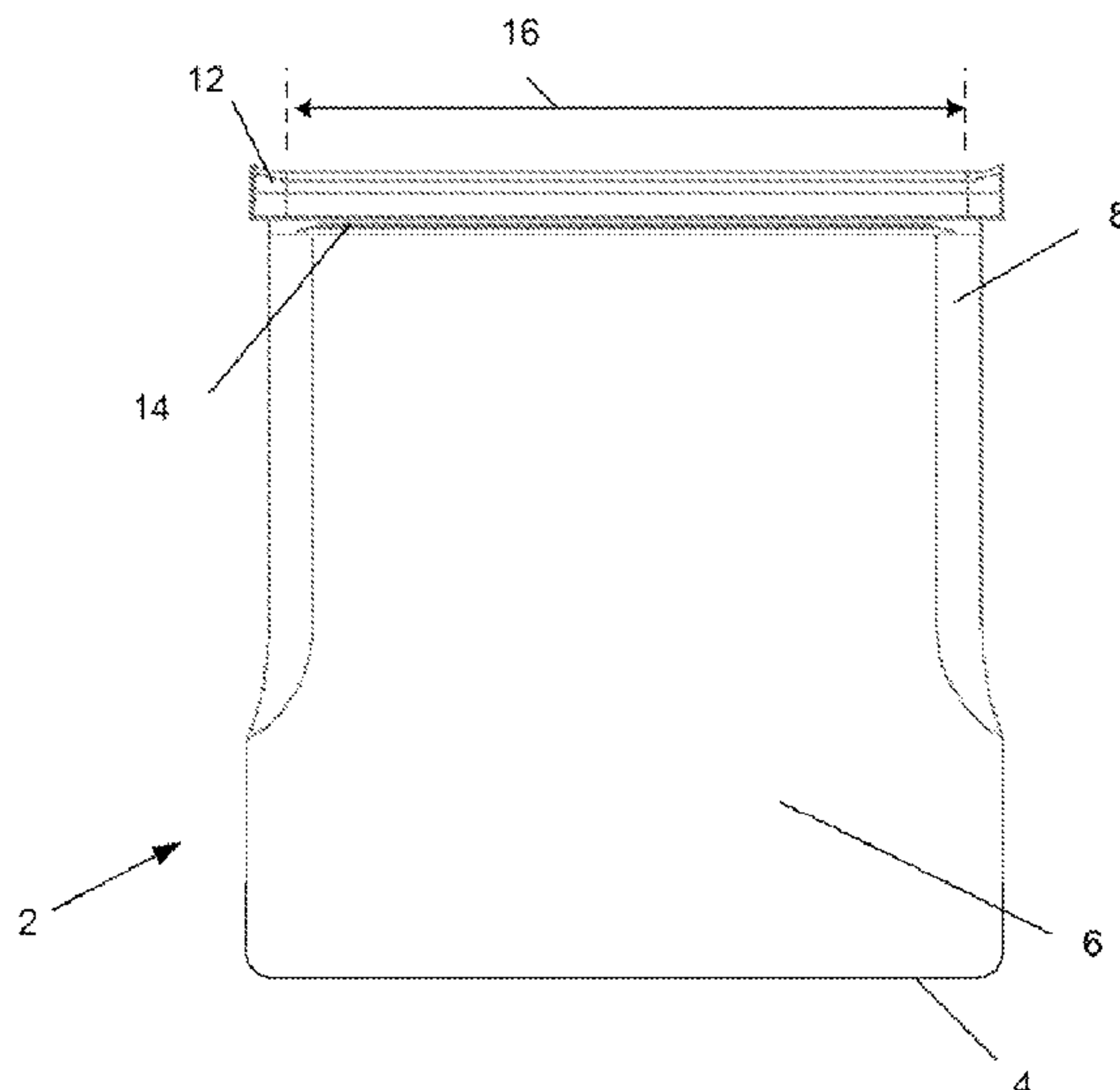

US 8,186,881 B2

Page 2

U.S. PATENT DOCUMENTS

6,074,094	A	6/2000	Manolizi	
6,199,256	B1	3/2001	Revnew et al.	
6,200,027	B1	3/2001	Jones	
6,267,506	B1	7/2001	Campion	
6,464,394	B1	10/2002	Galomb	
6,584,666	B1	7/2003	Savicki	
6,622,353	B2	9/2003	Provan et al.	
6,836,945	B2	1/2005	Savicki	
6,846,544	B2	1/2005	Buchman	
6,960,021	B2	11/2005	Schneider et al.	
8,043,005	B2 *	10/2011	Lyon et al. 383/69
2002/0094140	A1	7/2002	Gill	
2002/0154835	A1	10/2002	Galomb	

2003/0210837	A1	11/2003	Wedi et al.
2004/0055254	A1	3/2004	Setton
2004/0066990	A1	4/2004	Schneider et al.
2004/0081375	A1	4/2004	Pokusa
2004/0198944	A1	10/2004	Meltzer et al.
2005/0123218	A1	6/2005	Pokusa
2007/0280564	A1	12/2007	Lyon et al.
2007/0280565	A1	12/2007	Lyon et al.

FOREIGN PATENT DOCUMENTS

GB	2266701 A	11/1993
IT	544362	6/1956
IT	597773	9/1959

* cited by examiner

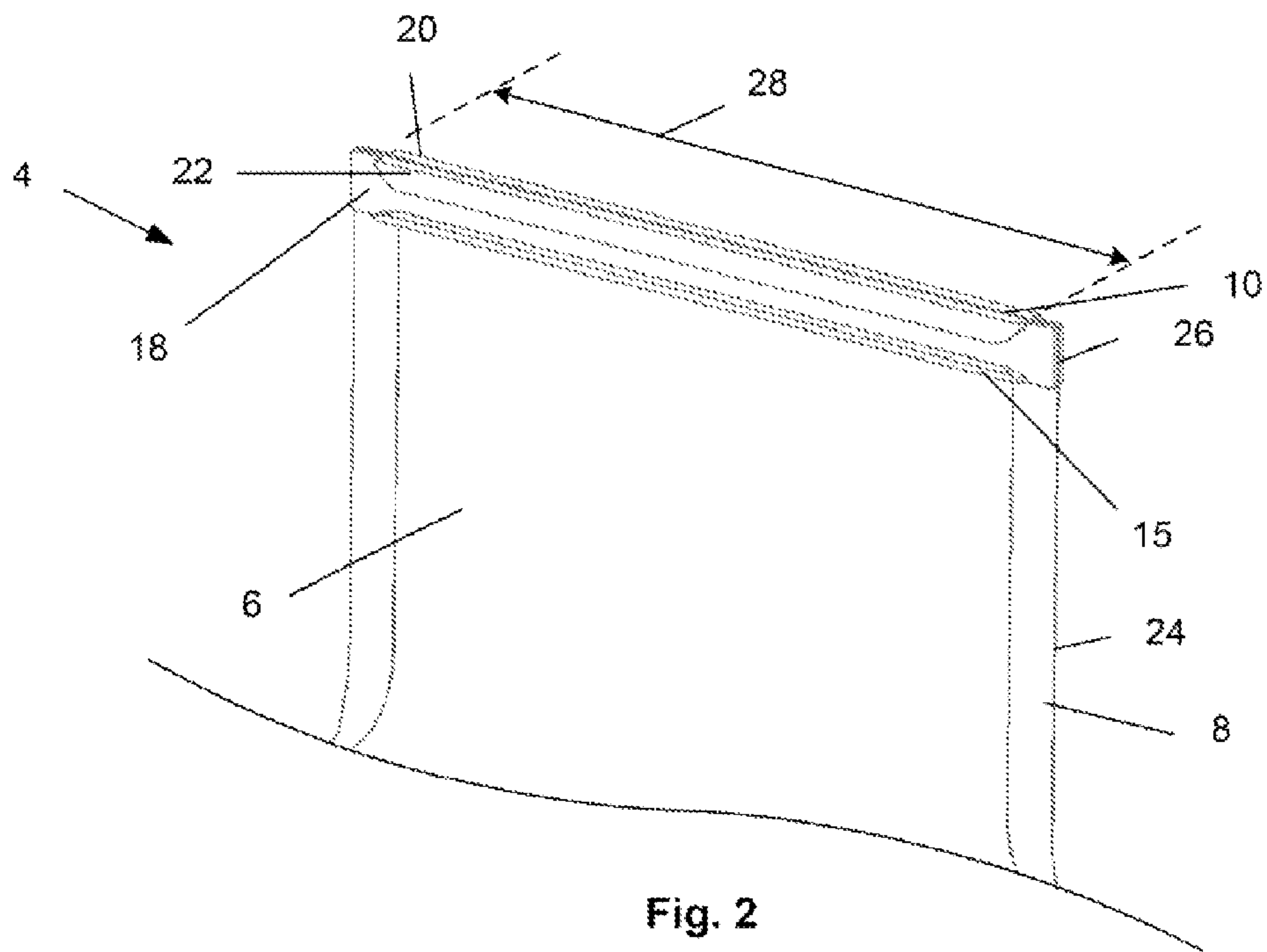
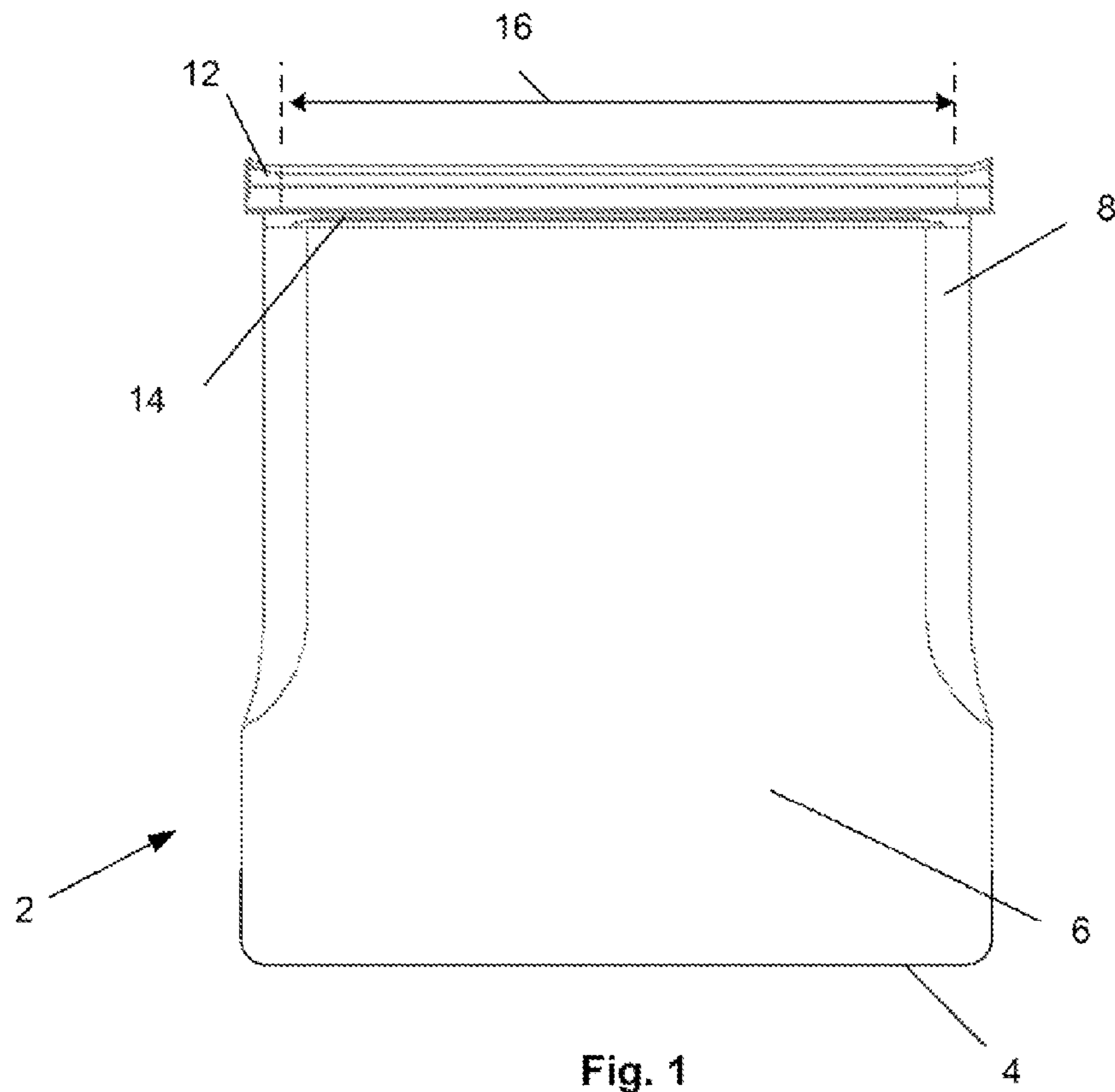

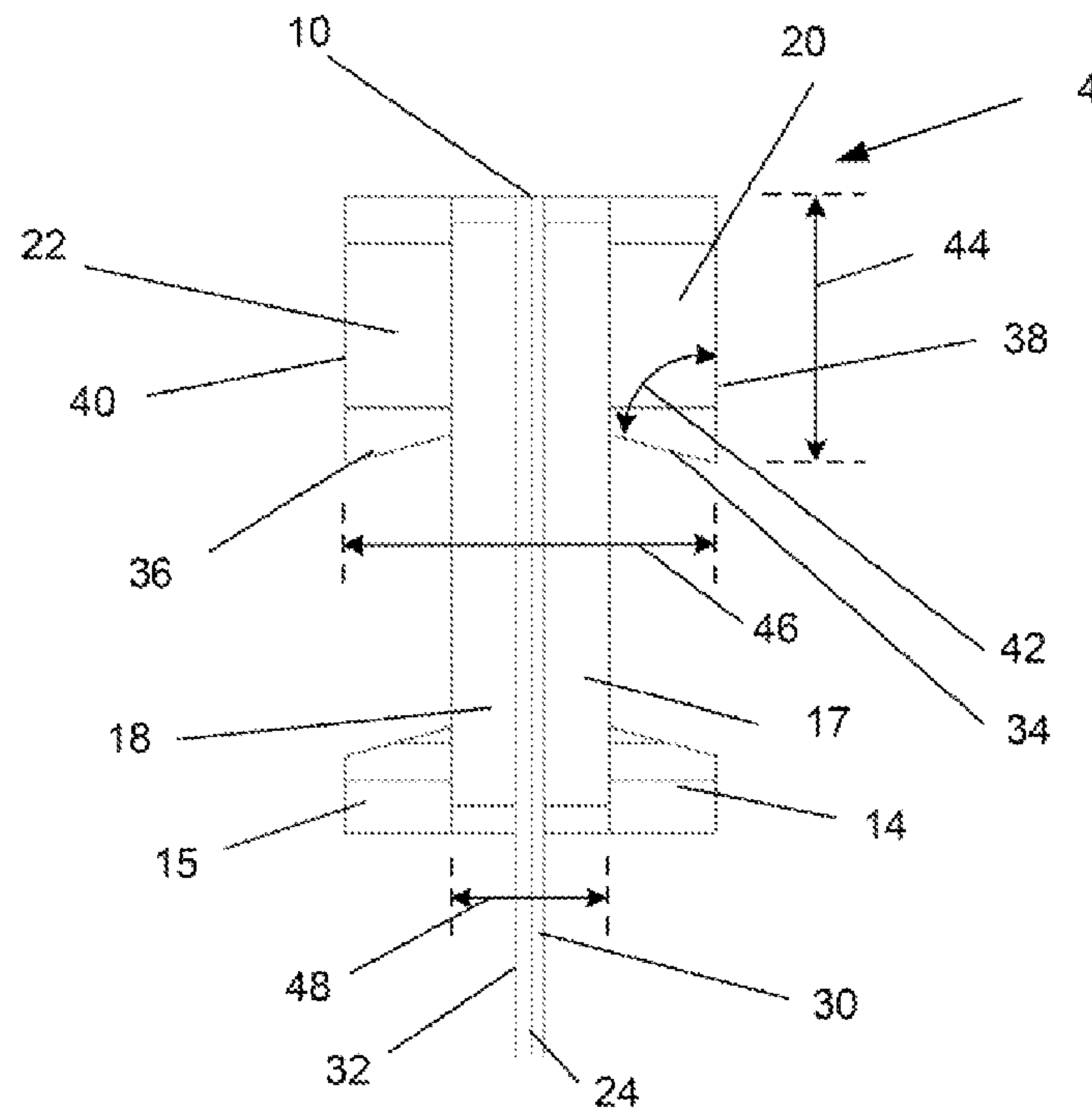

Fig. 3a

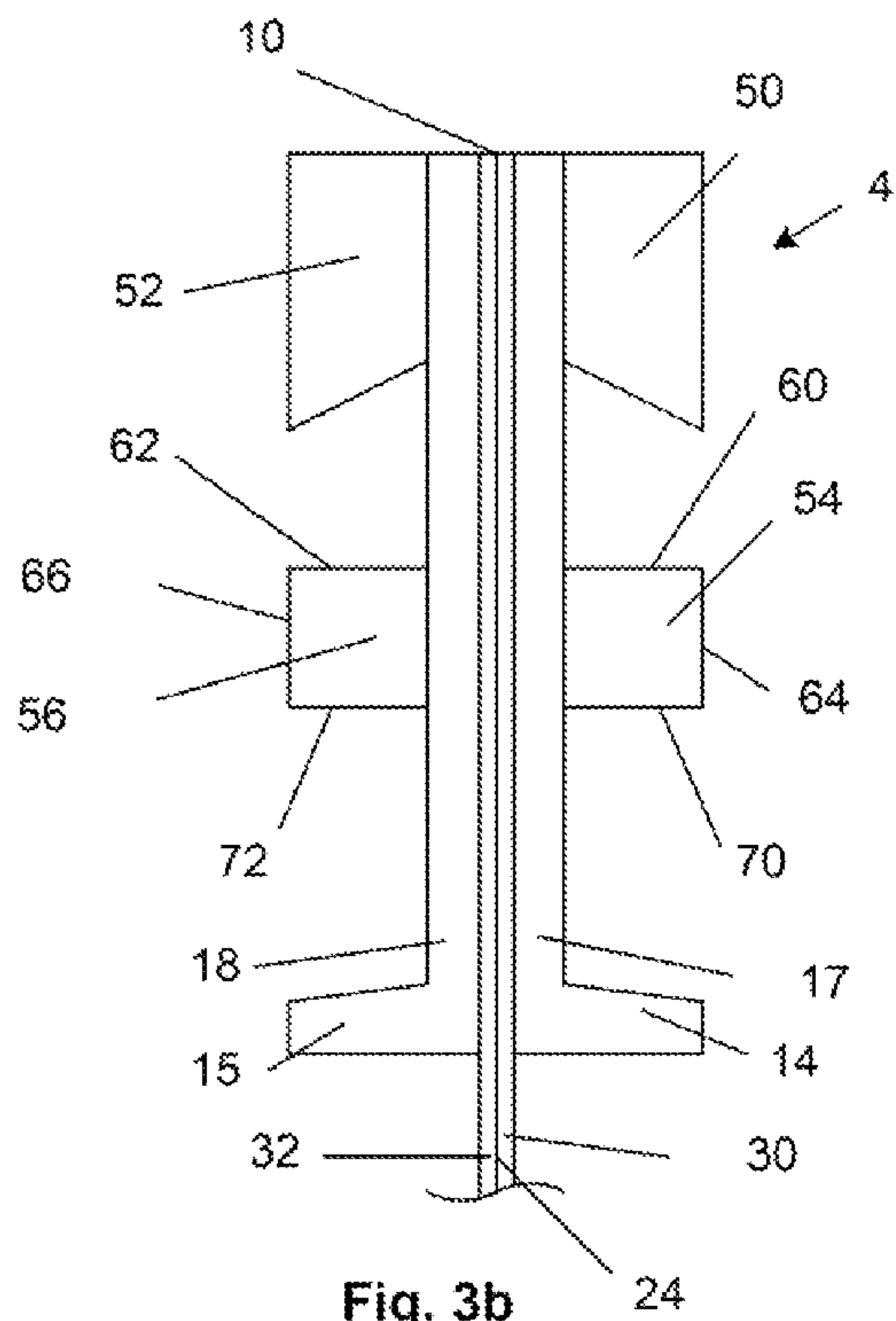

Fig. 3b

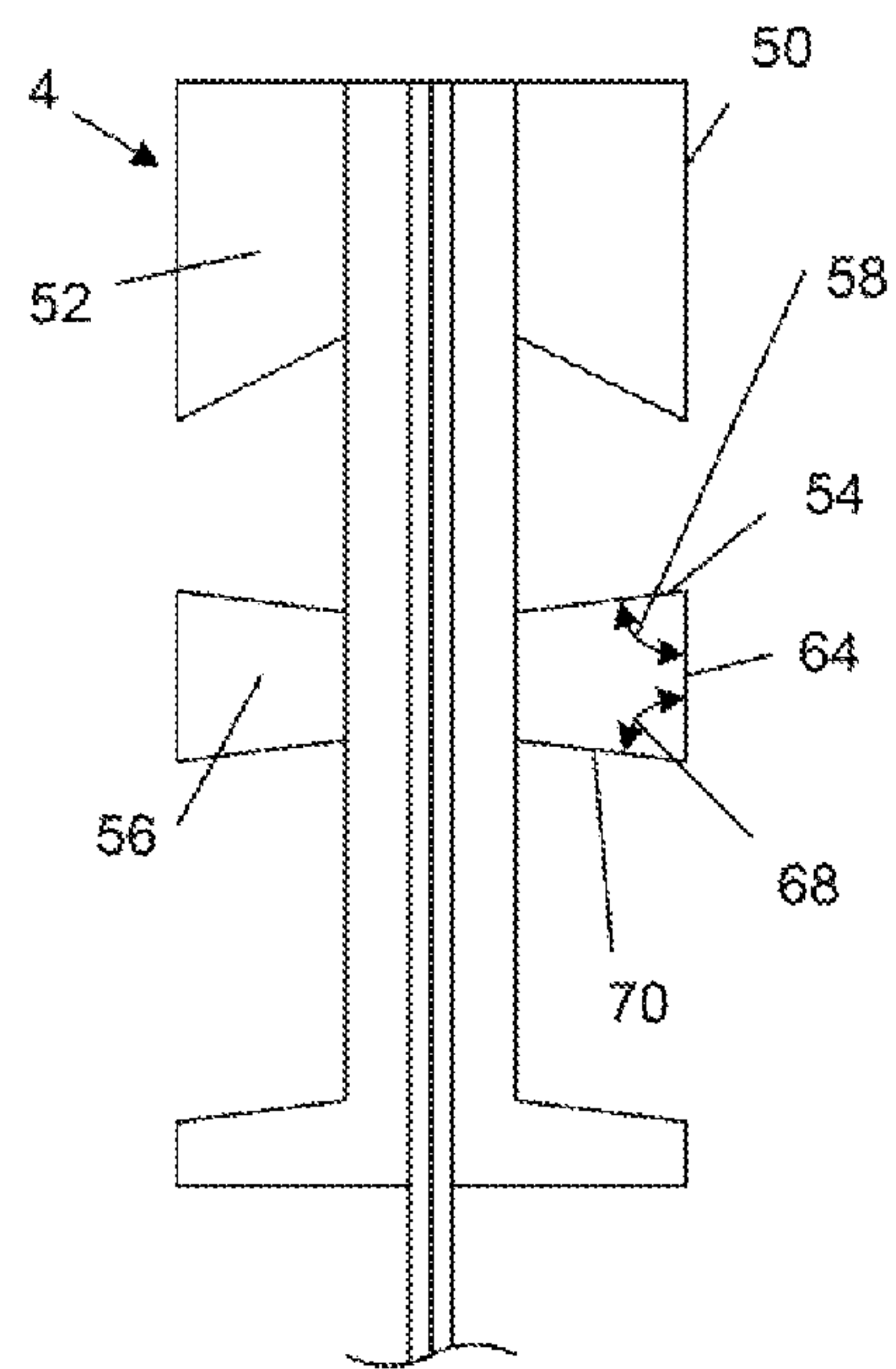
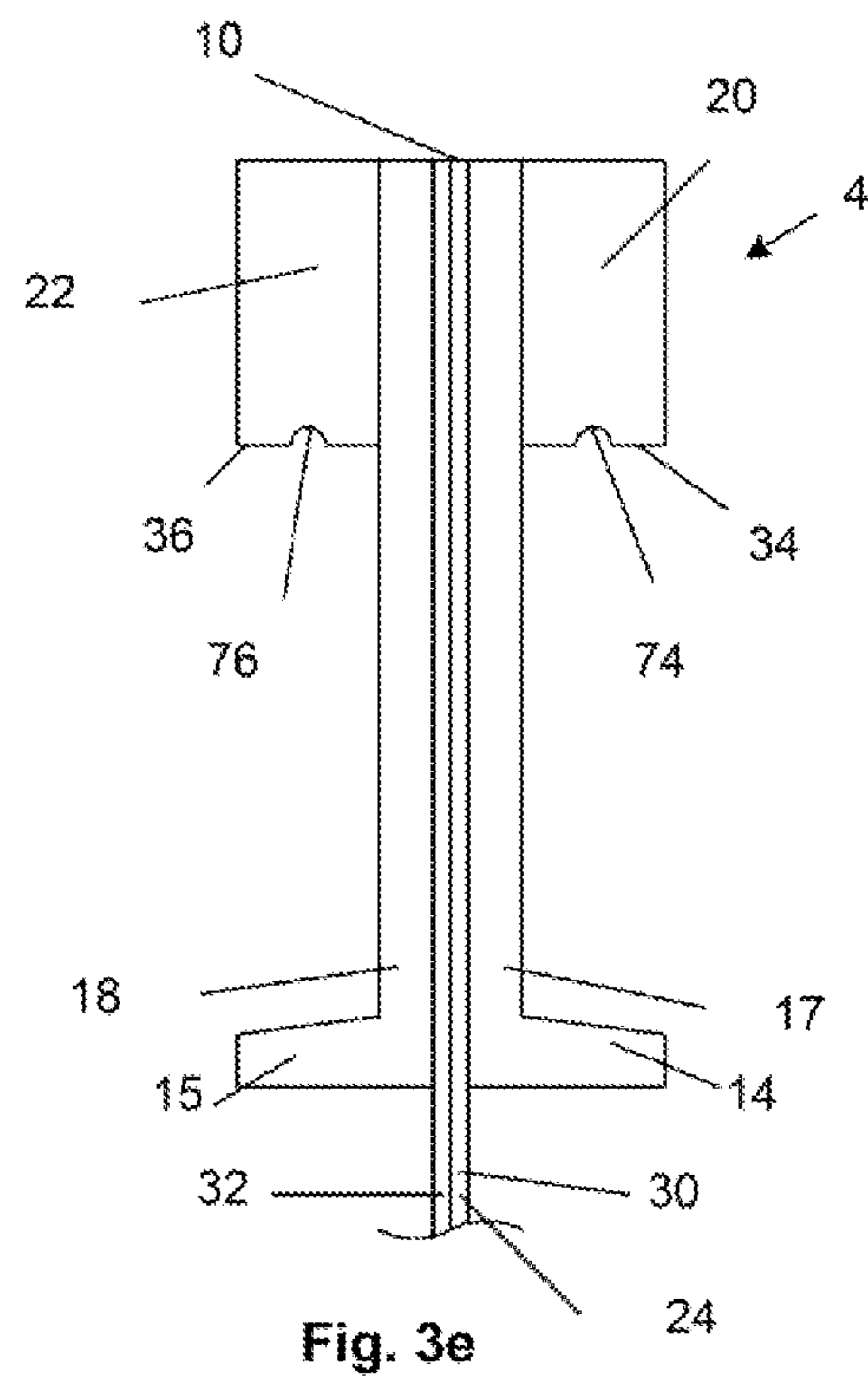
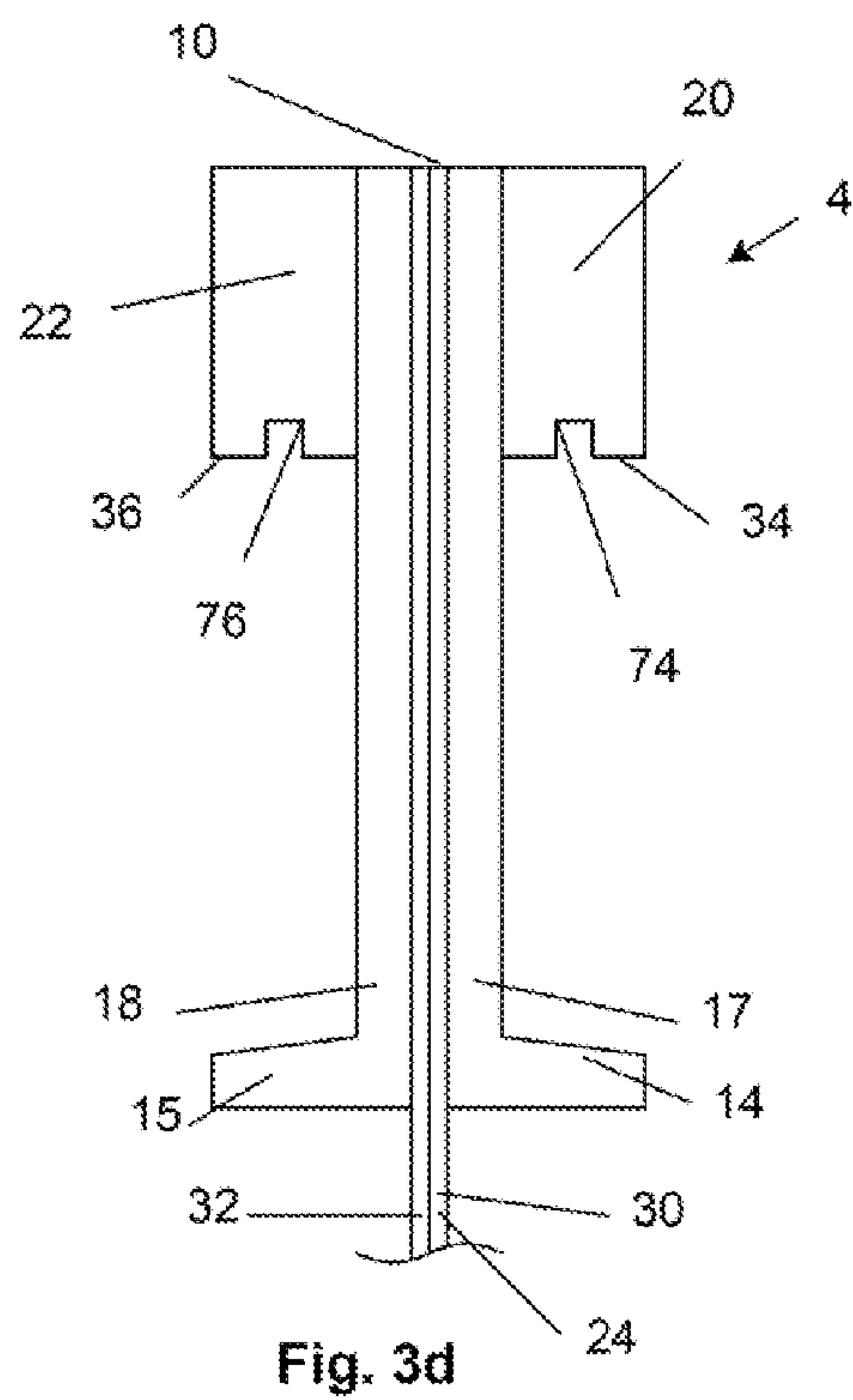
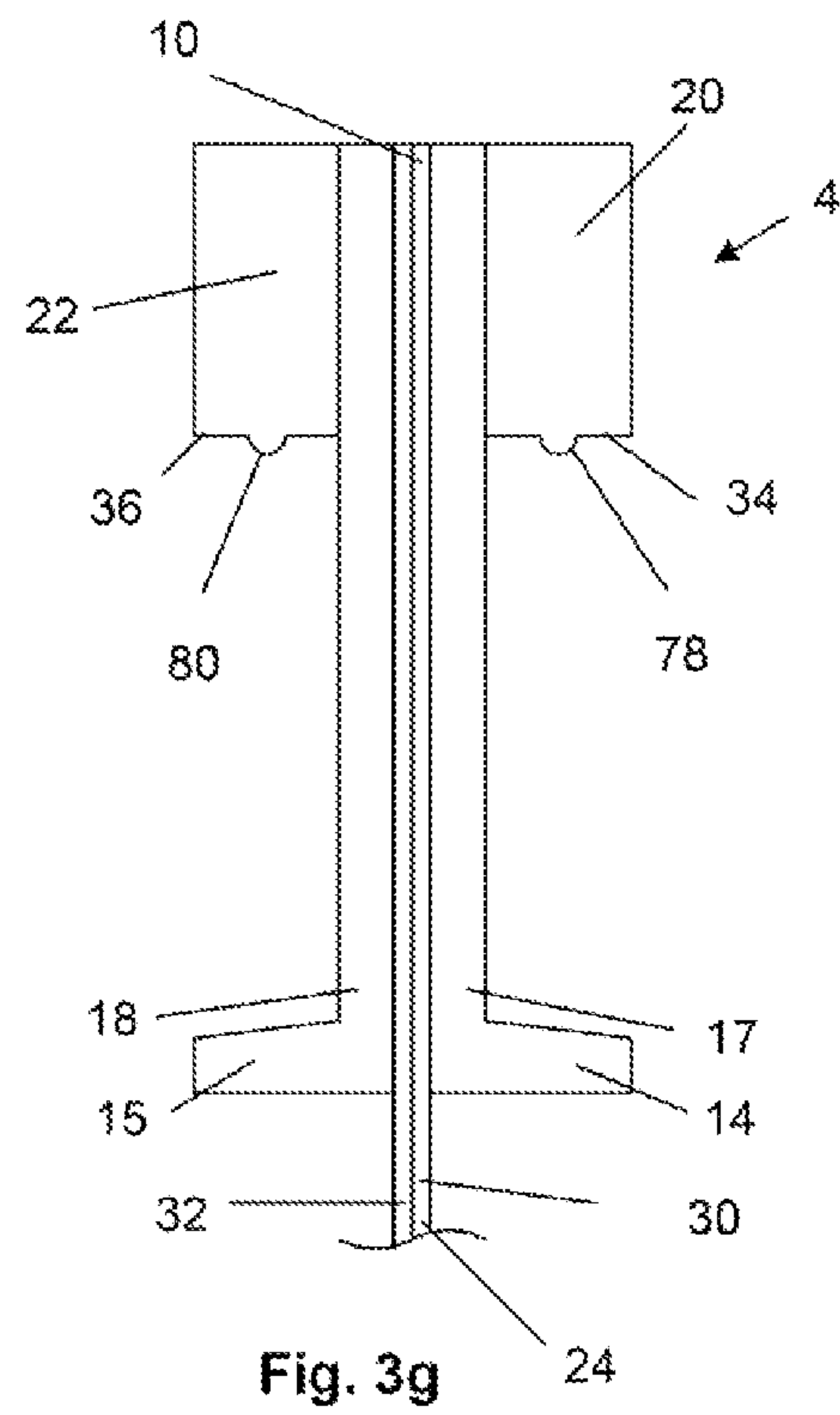
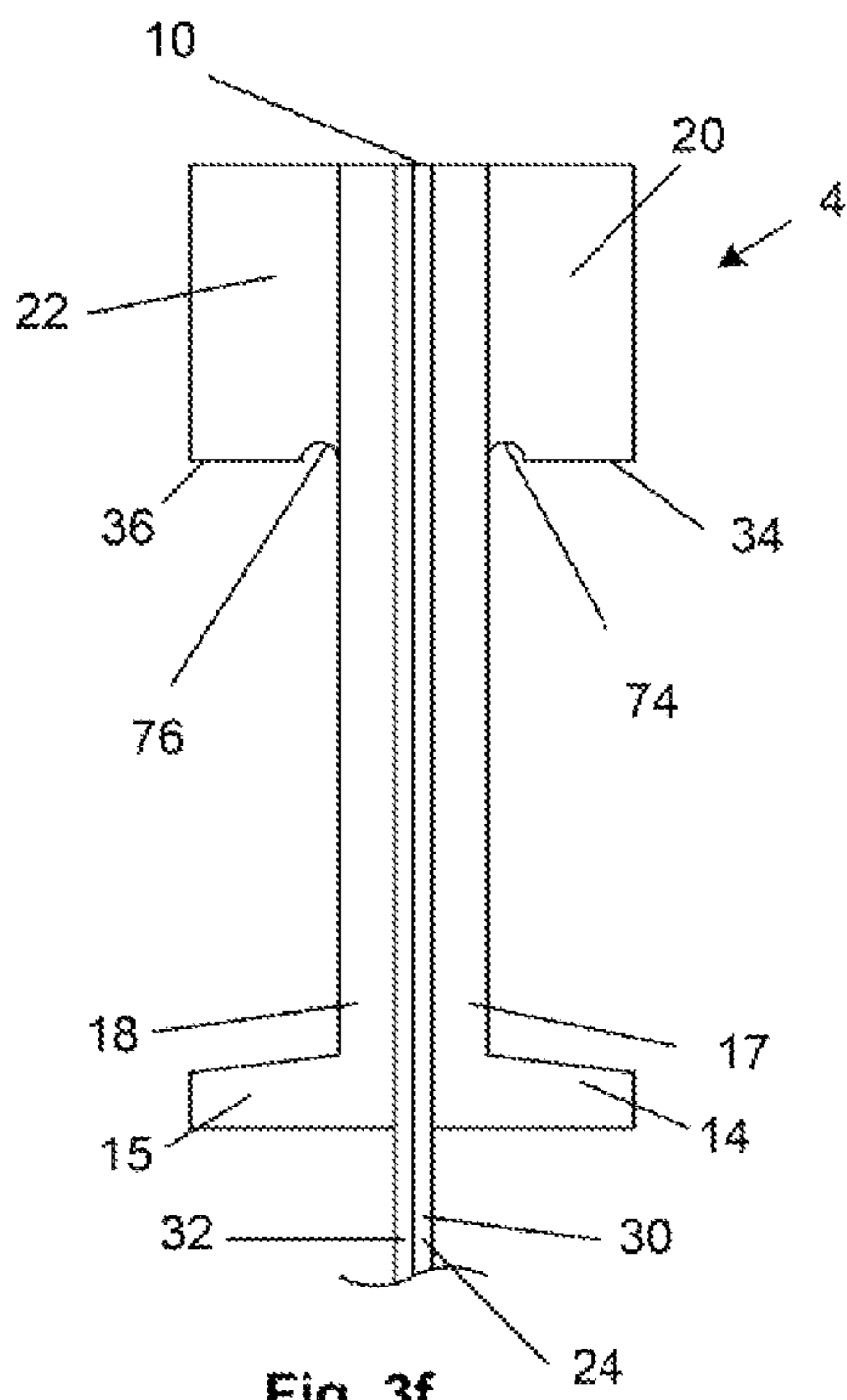
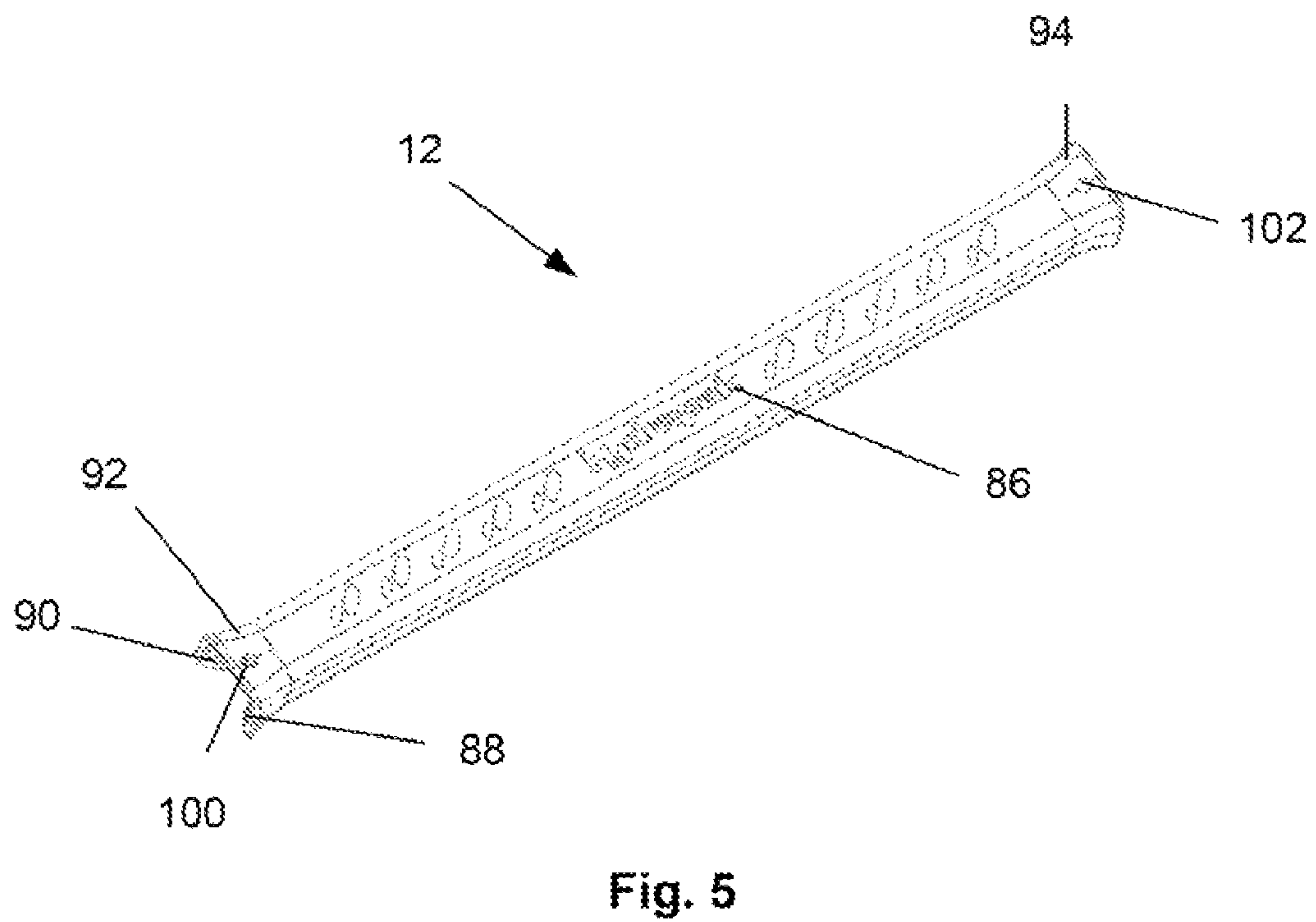
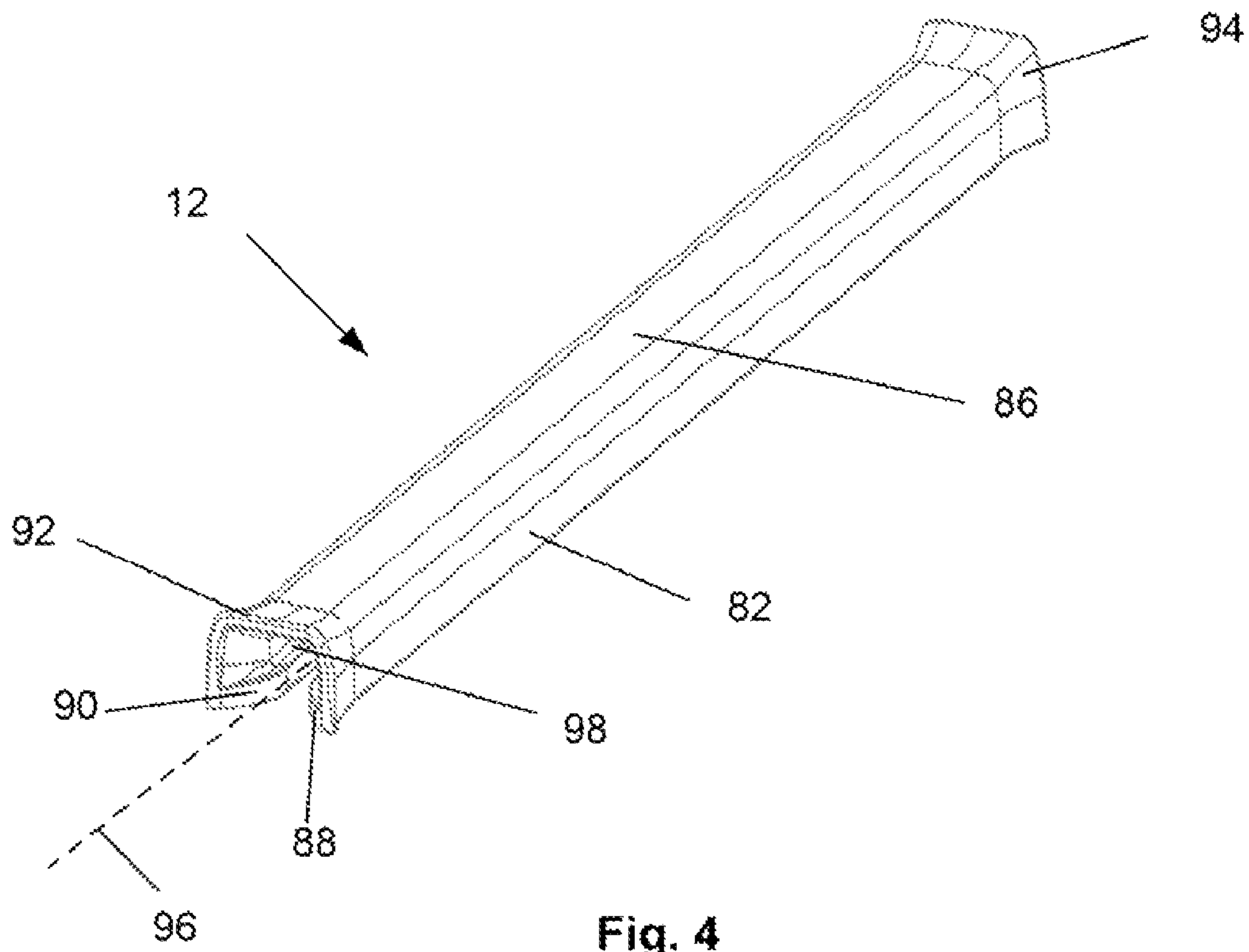

Fig. 3c







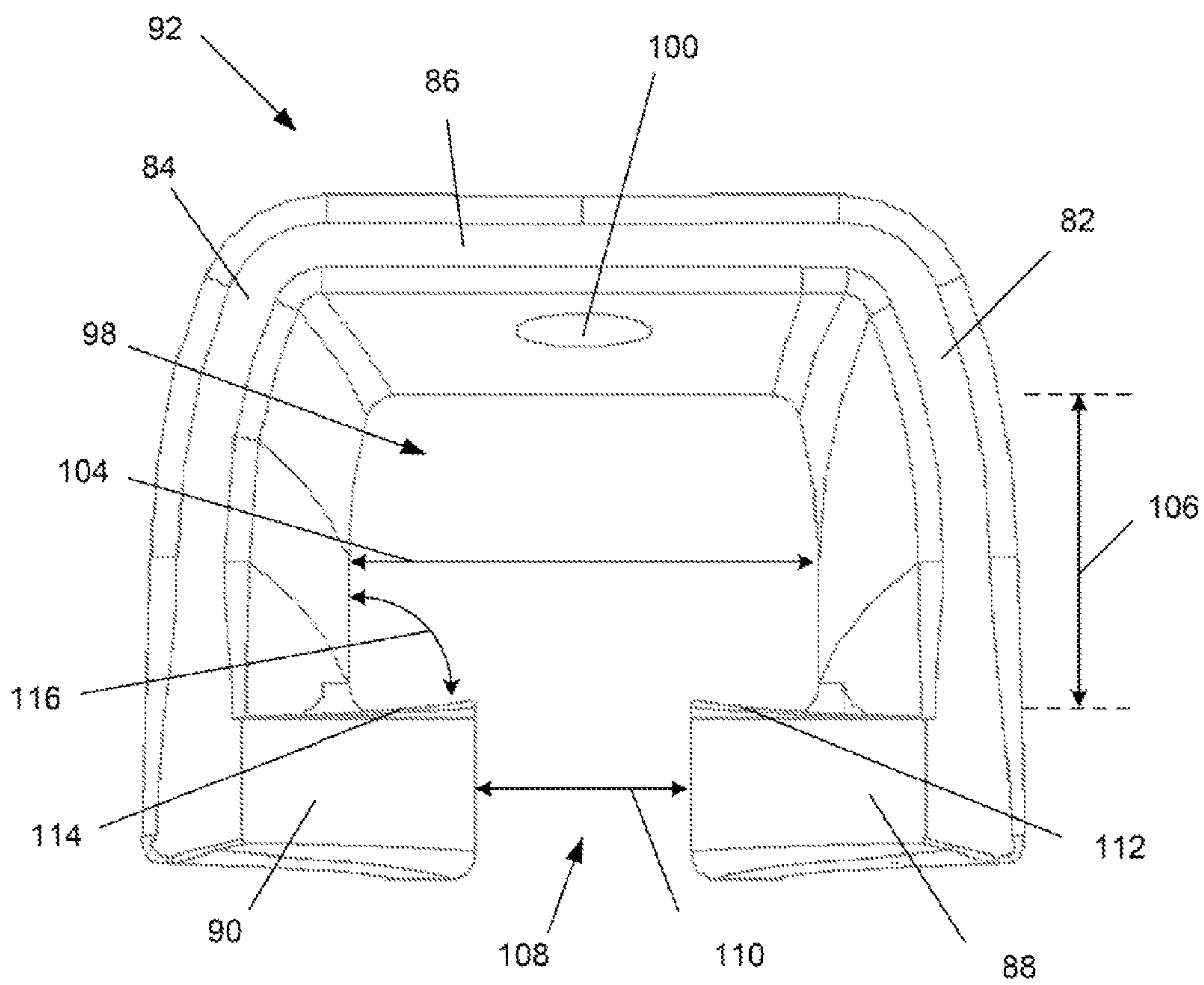
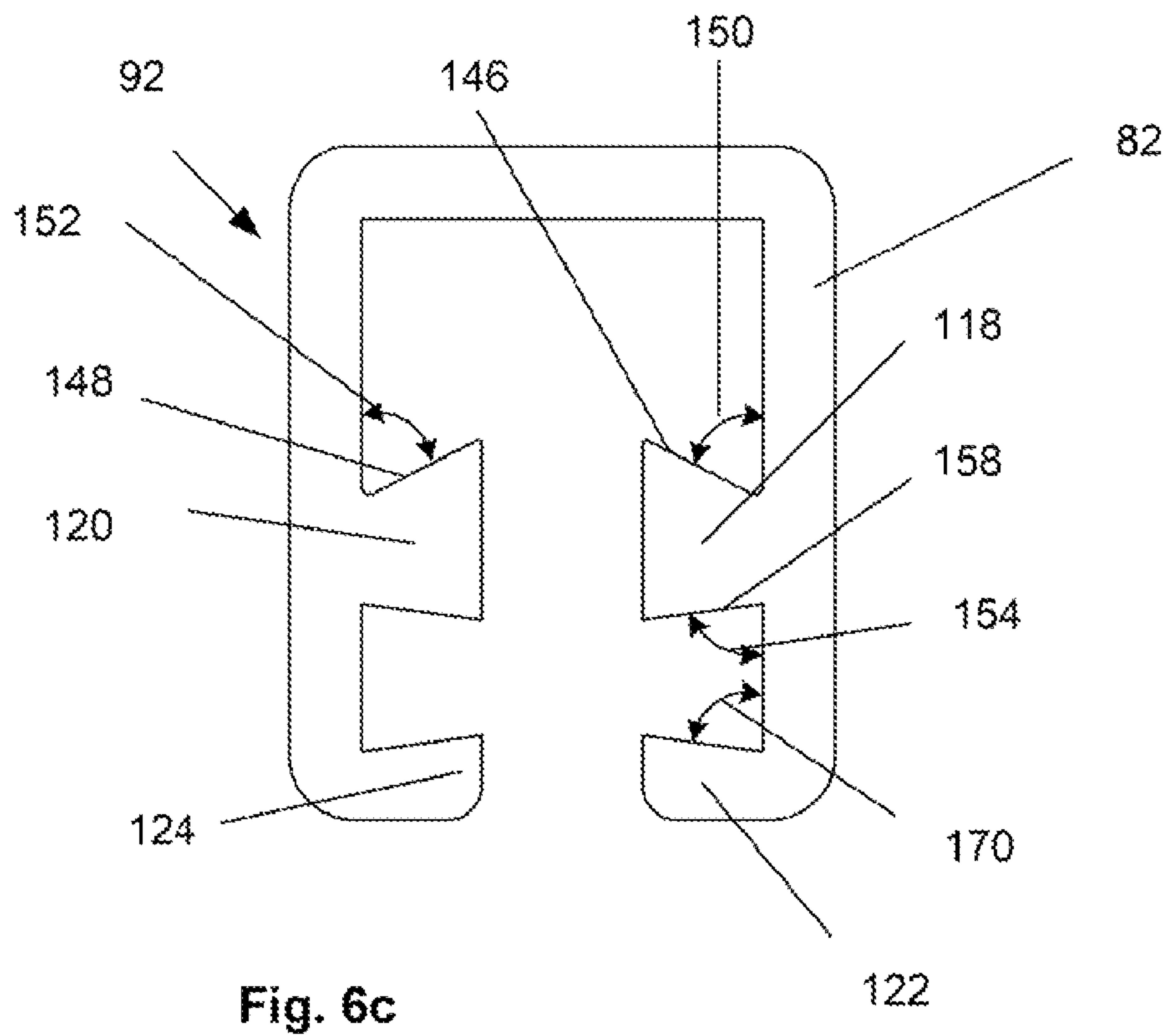
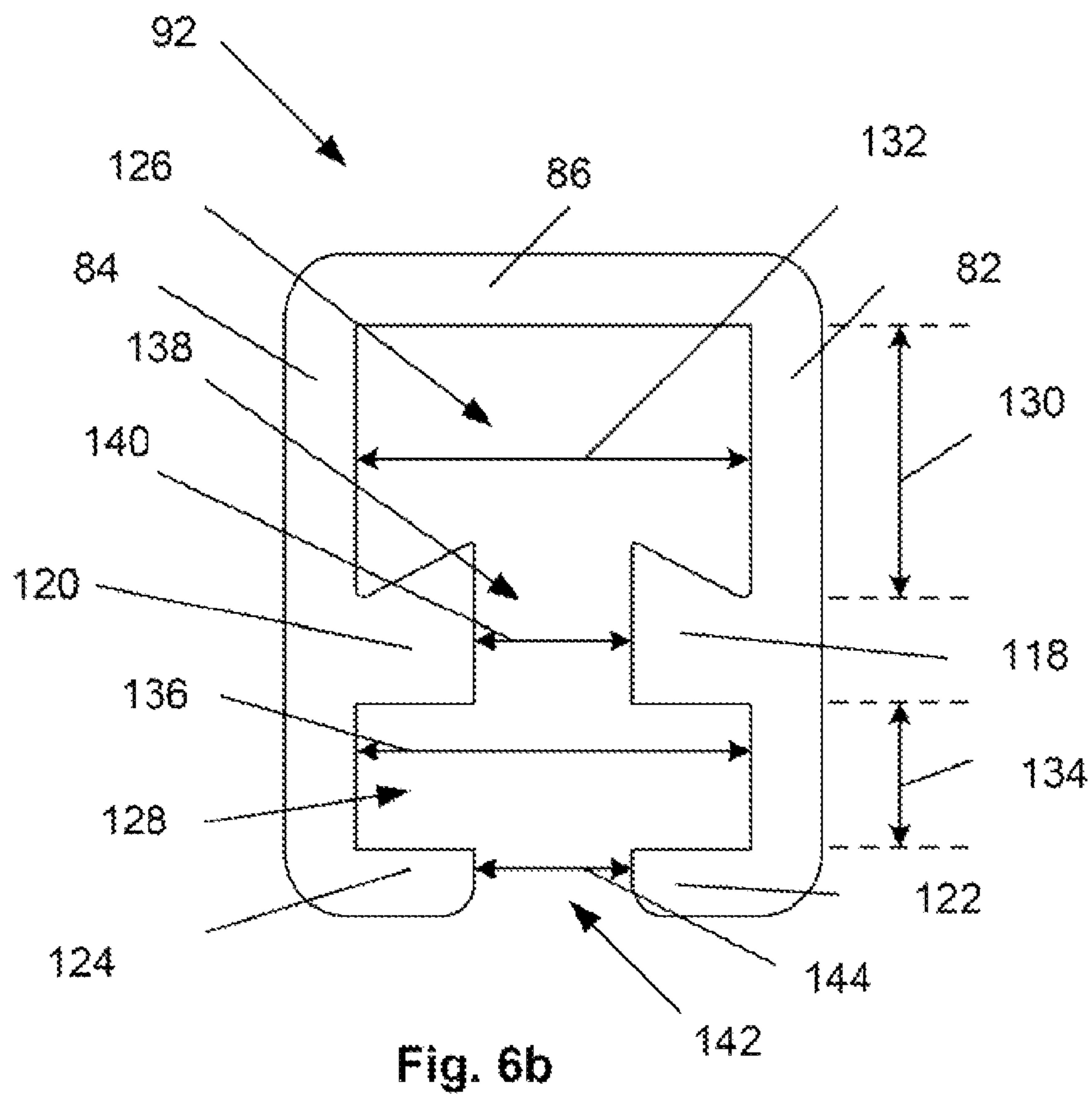

Fig. 6a



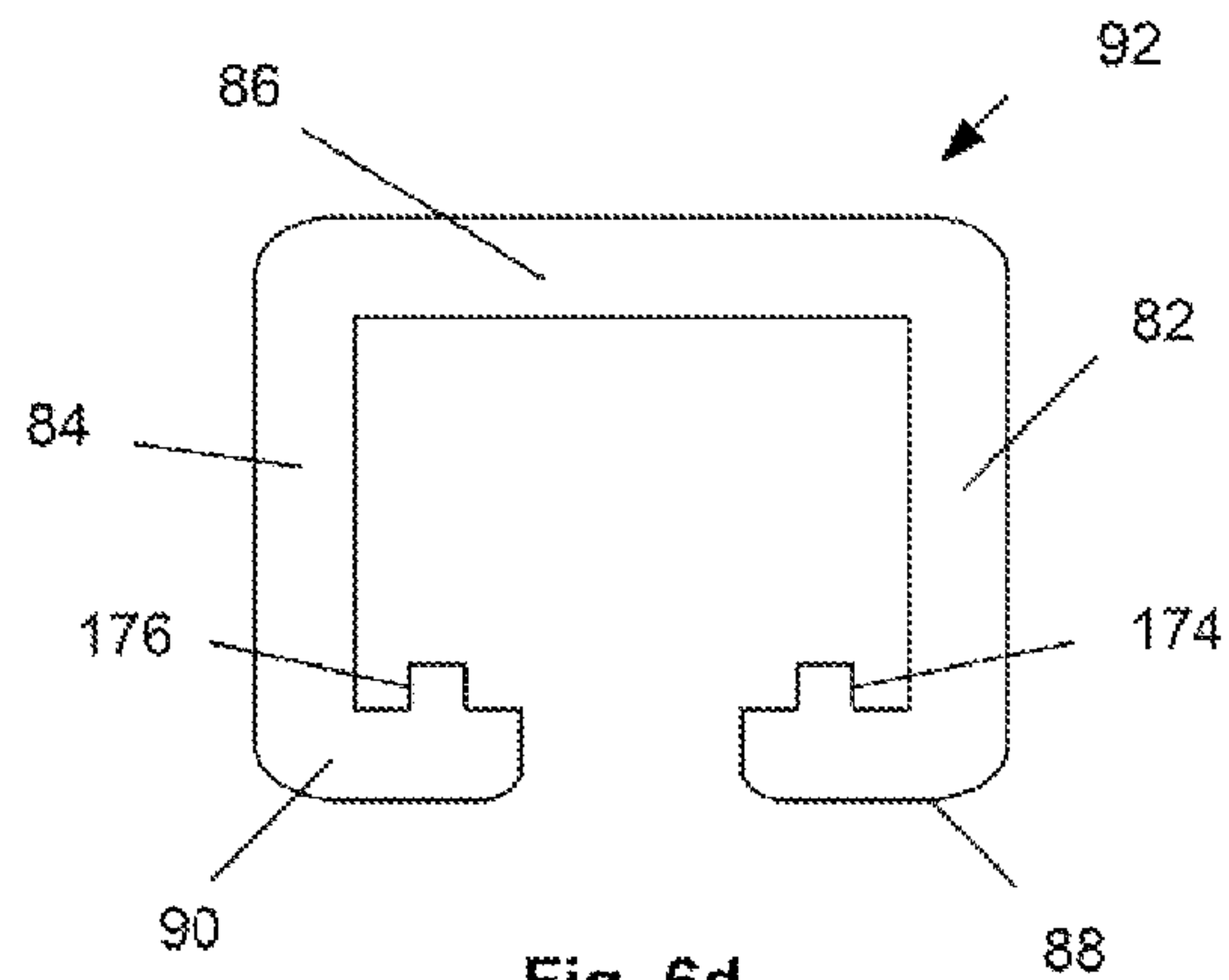

Fig. 6d

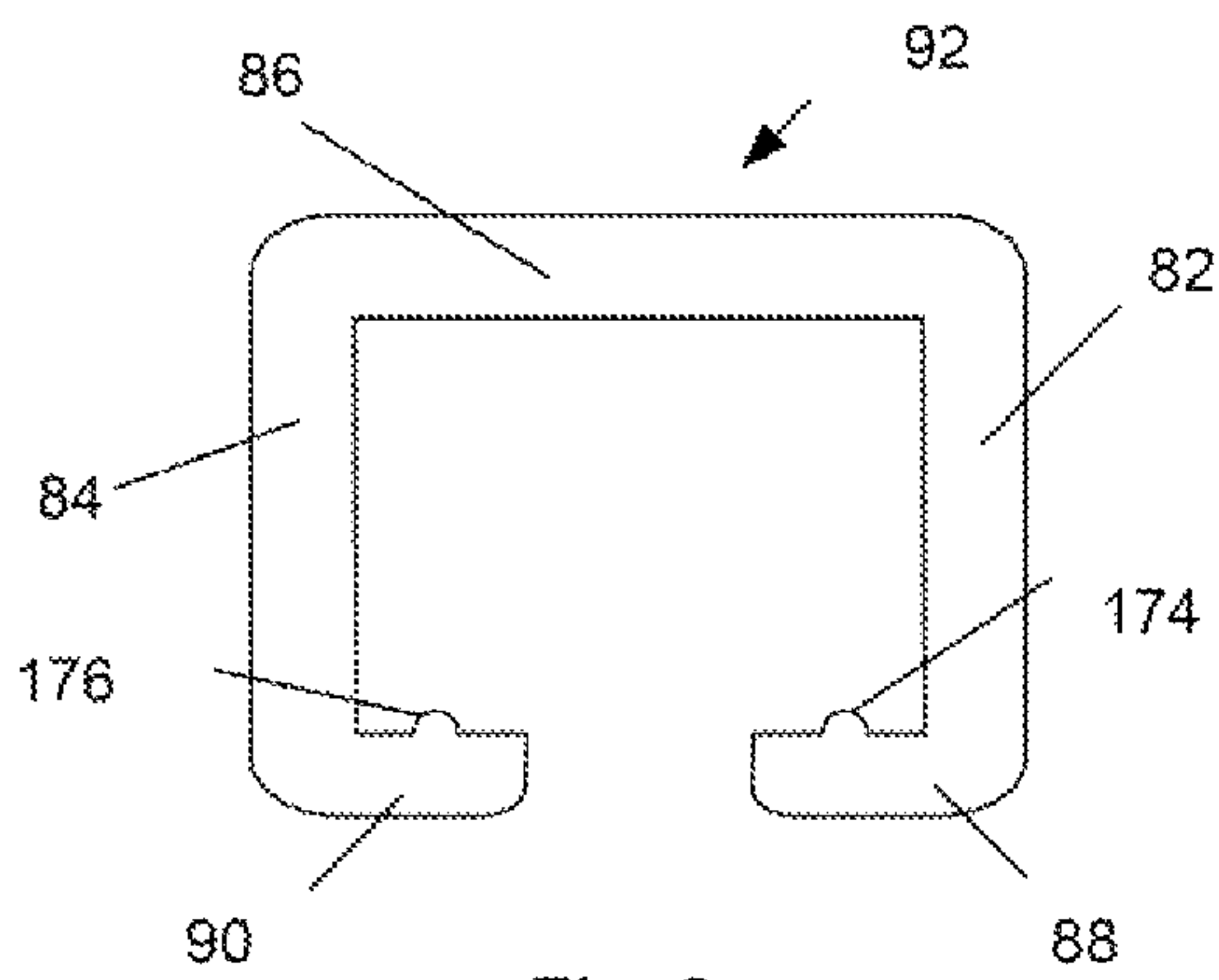

Fig. 6e

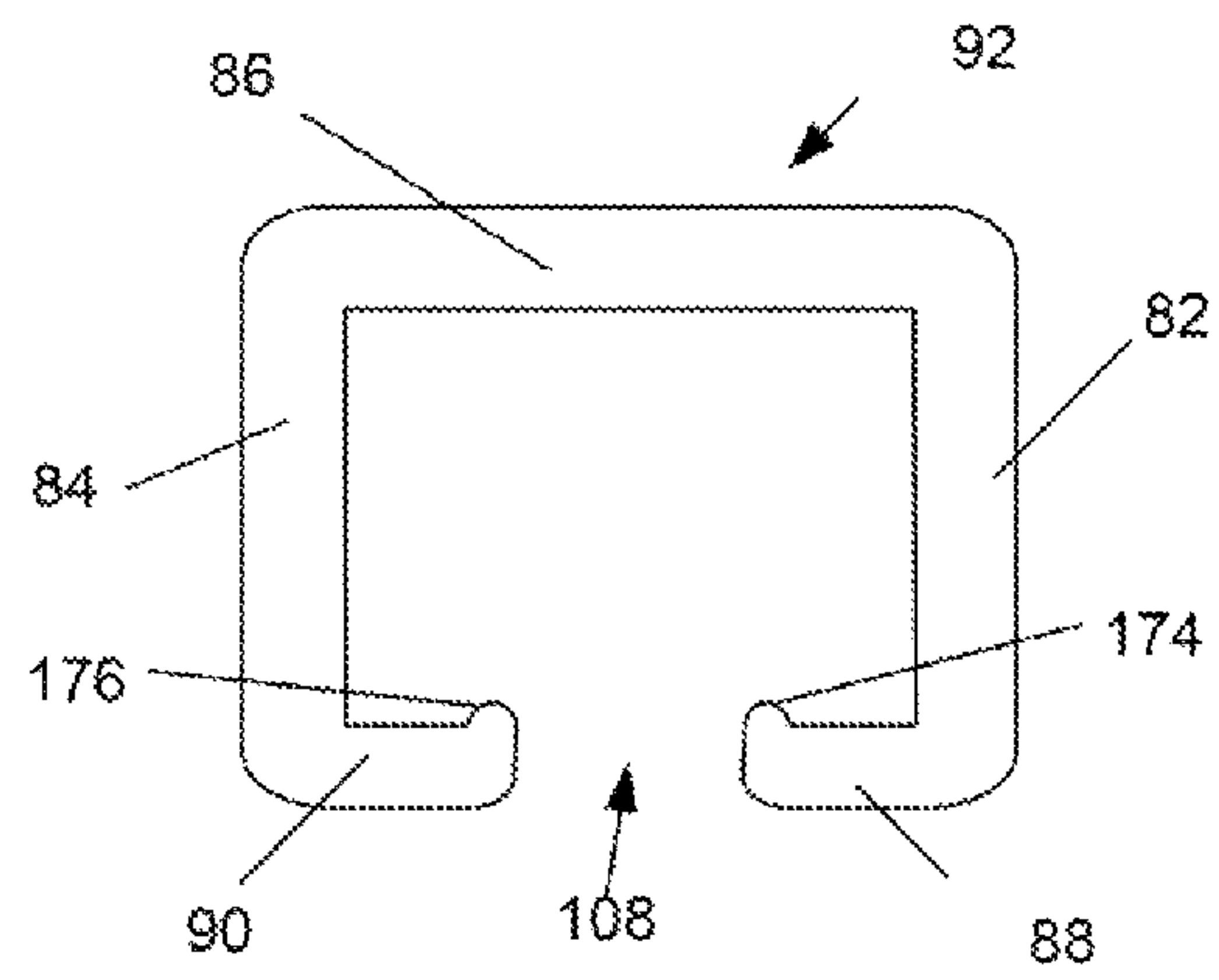

Fig. 6f

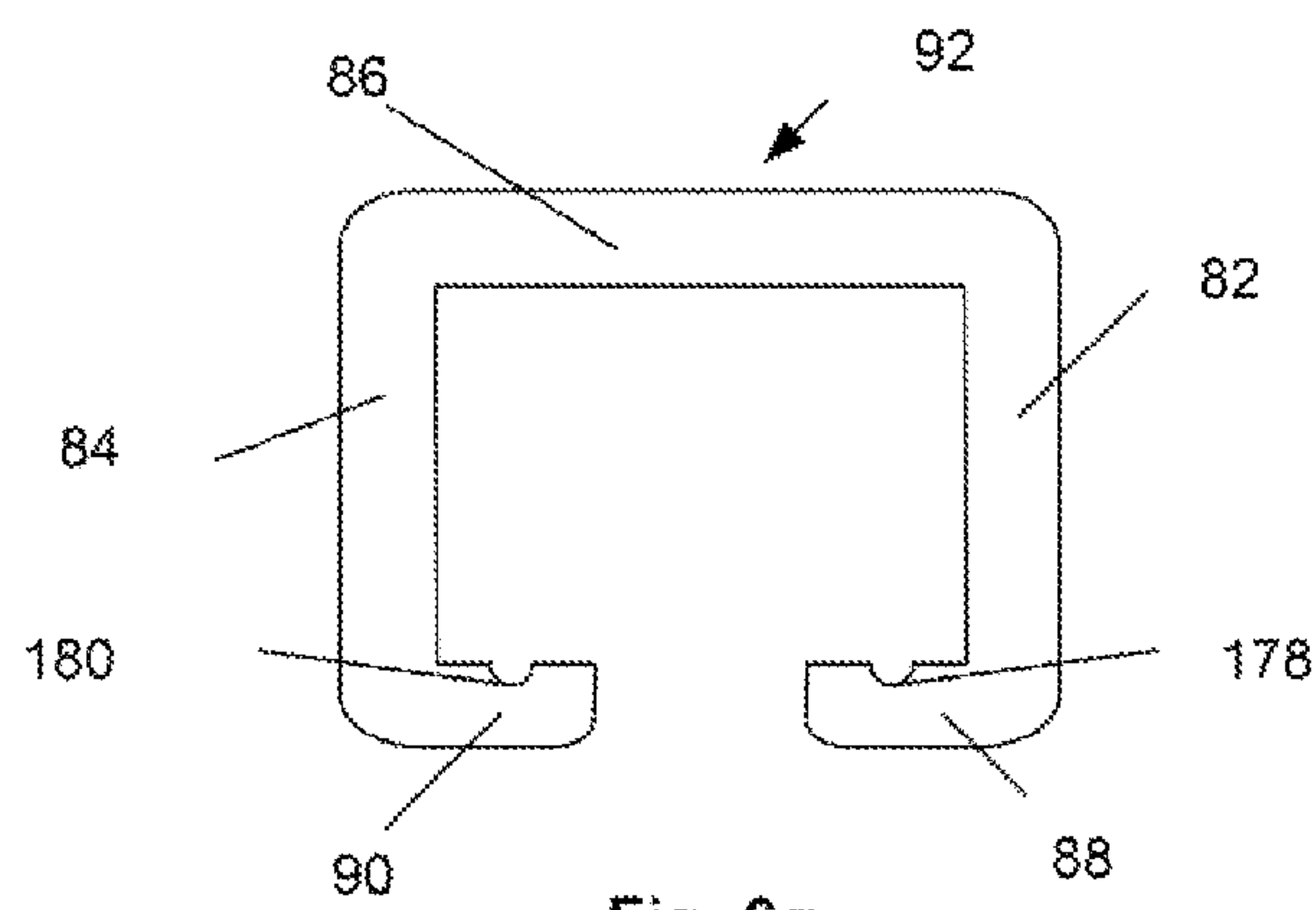

Fig. 6g

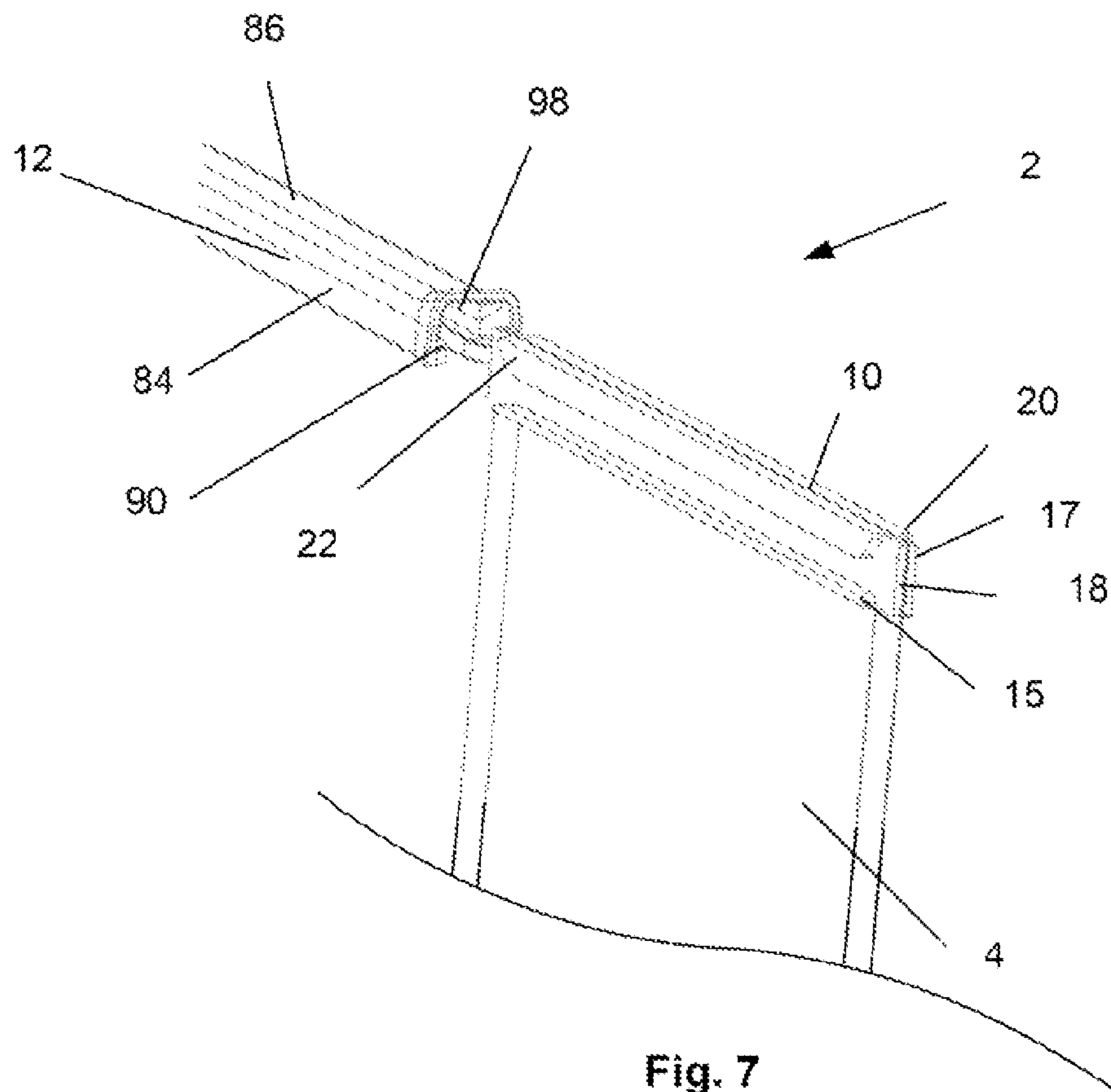

Fig. 7

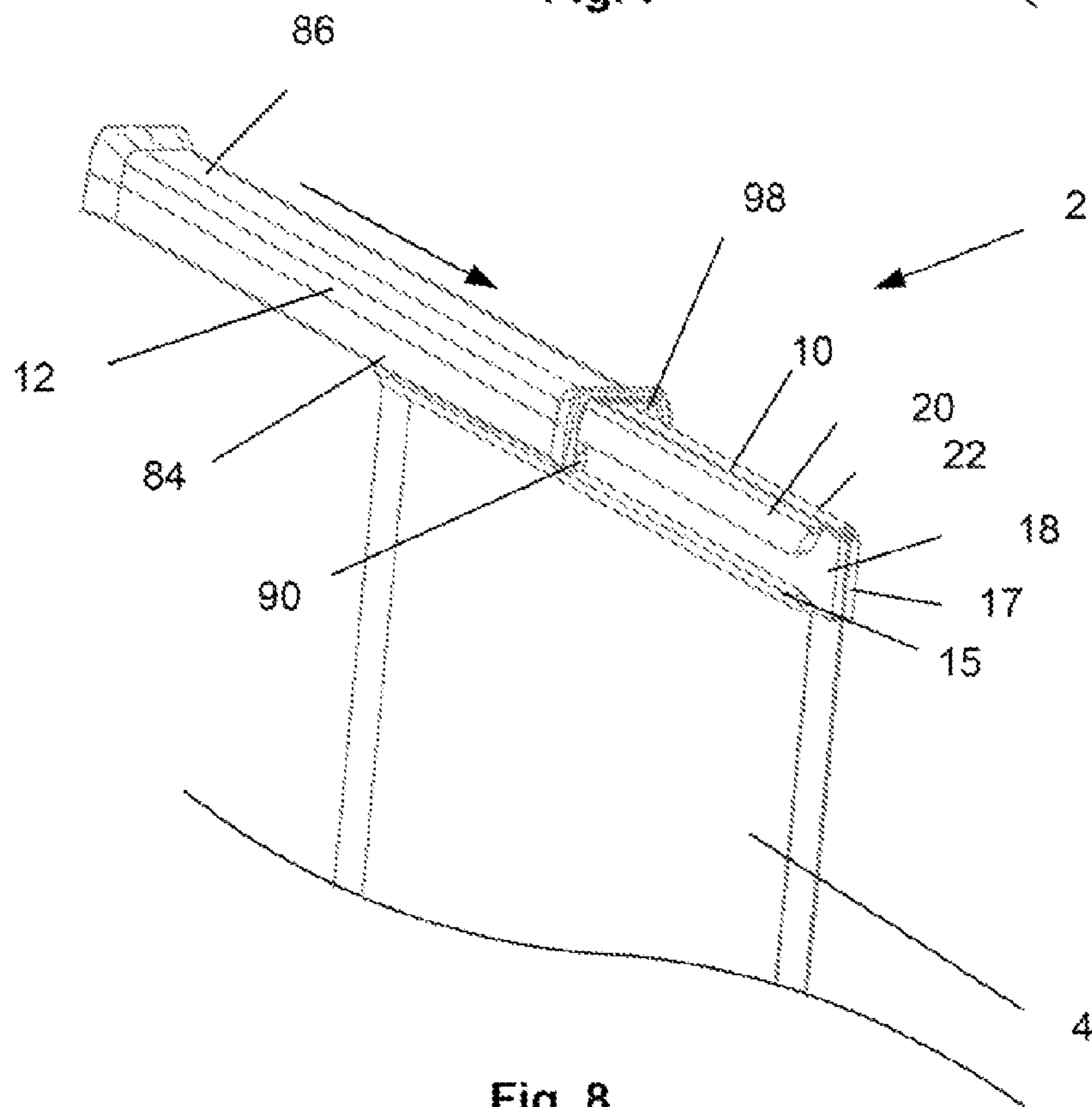

Fig. 8

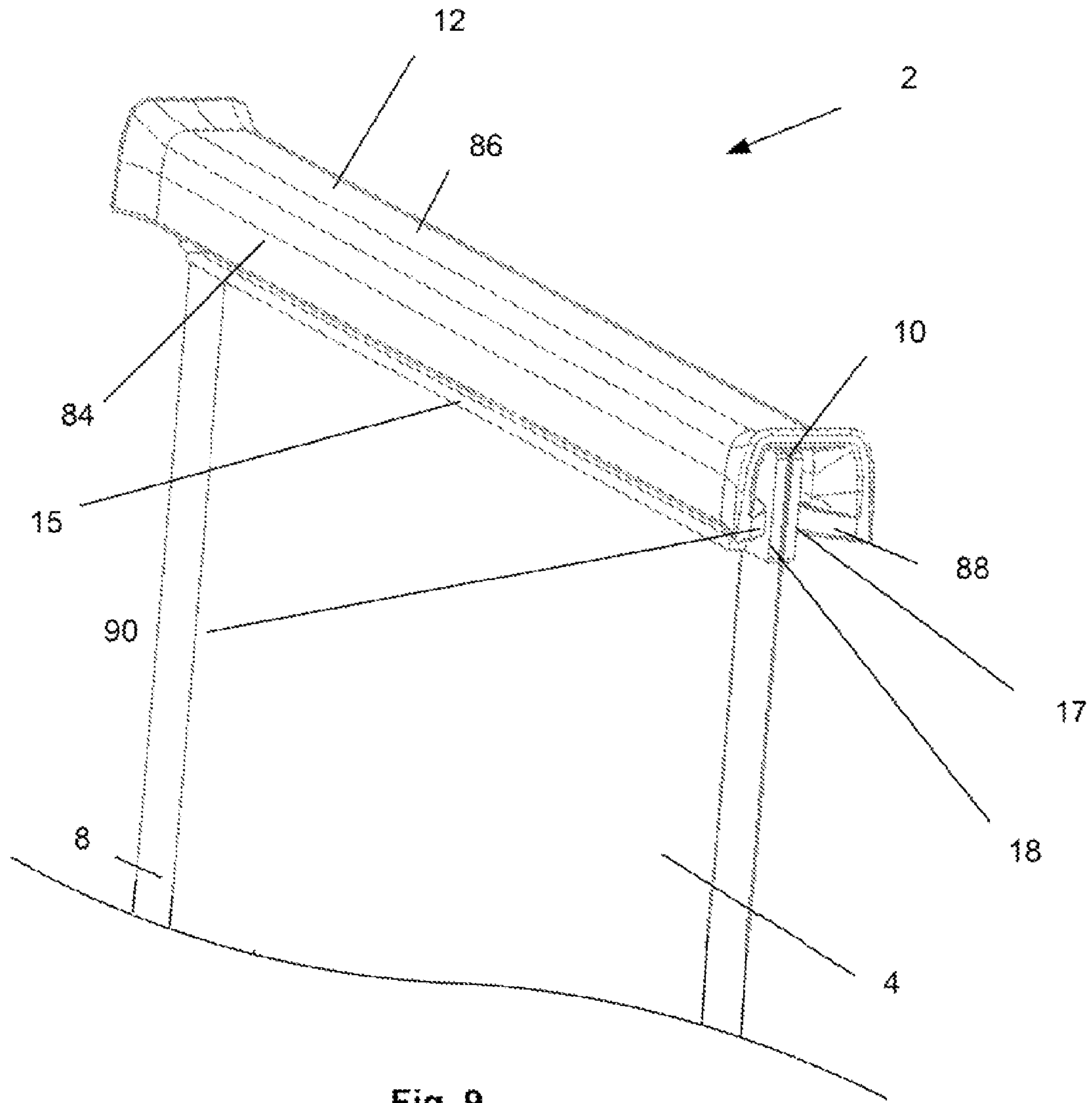

Fig. 9

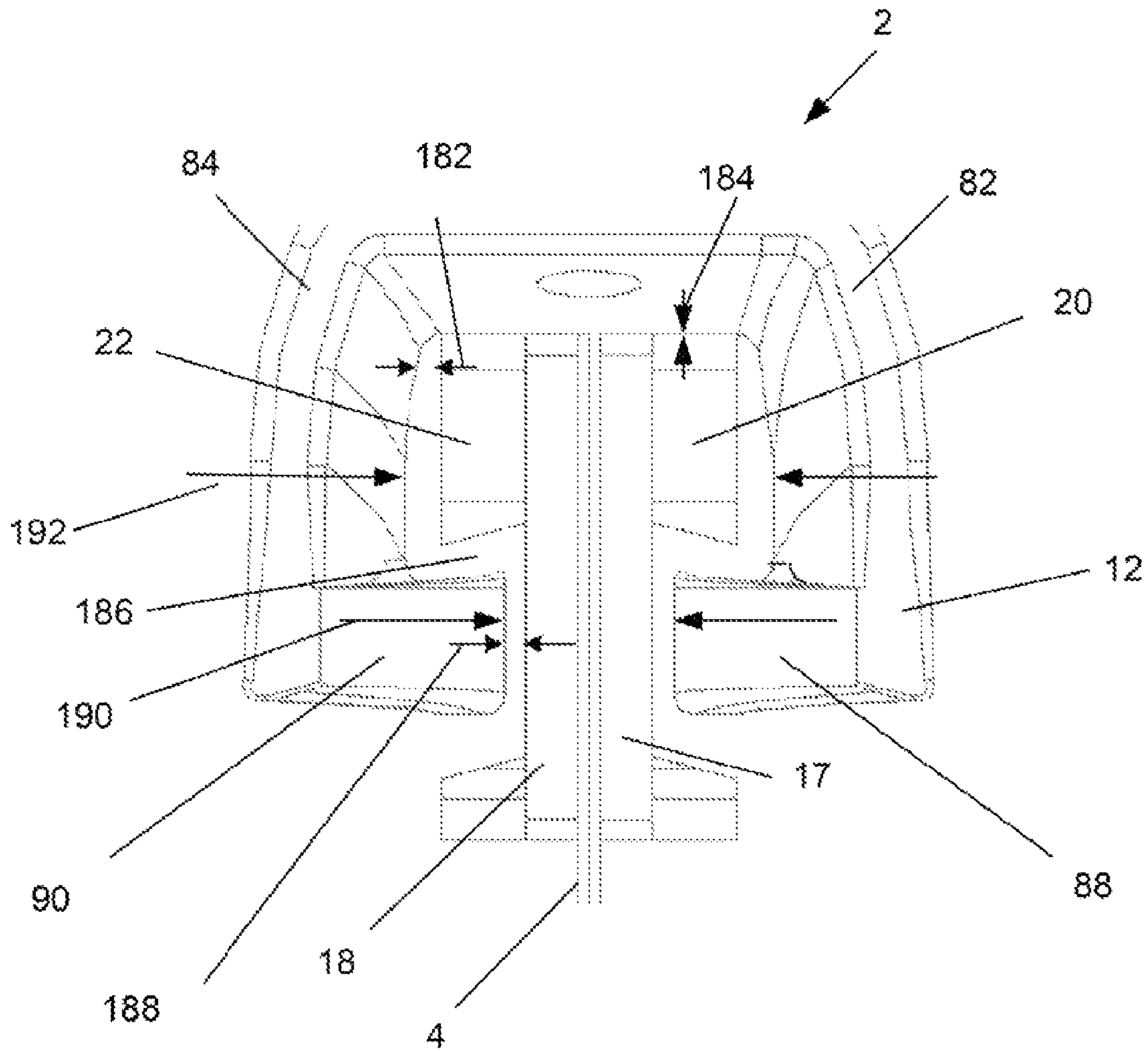

Fig. 10a

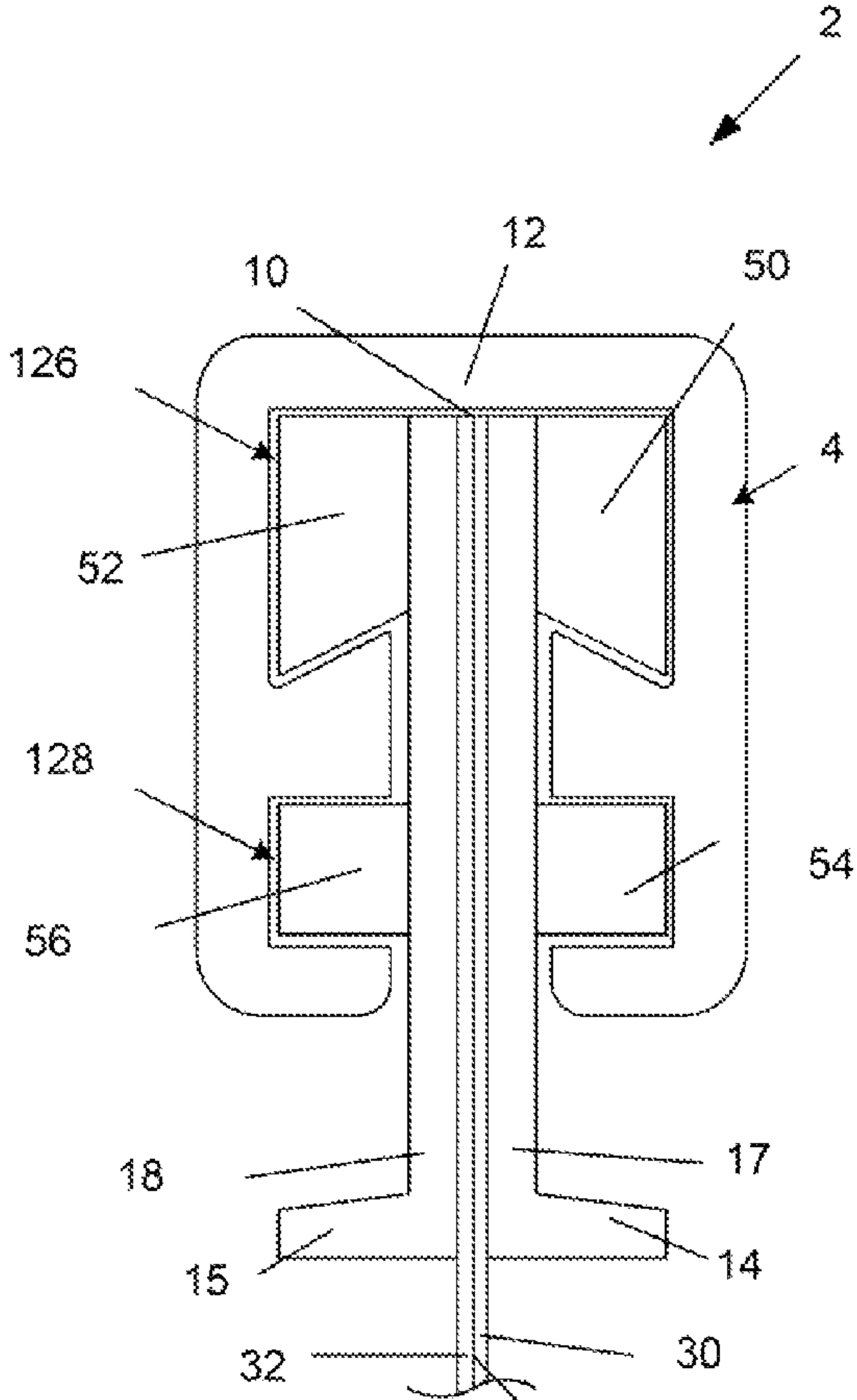

Fig. 10b

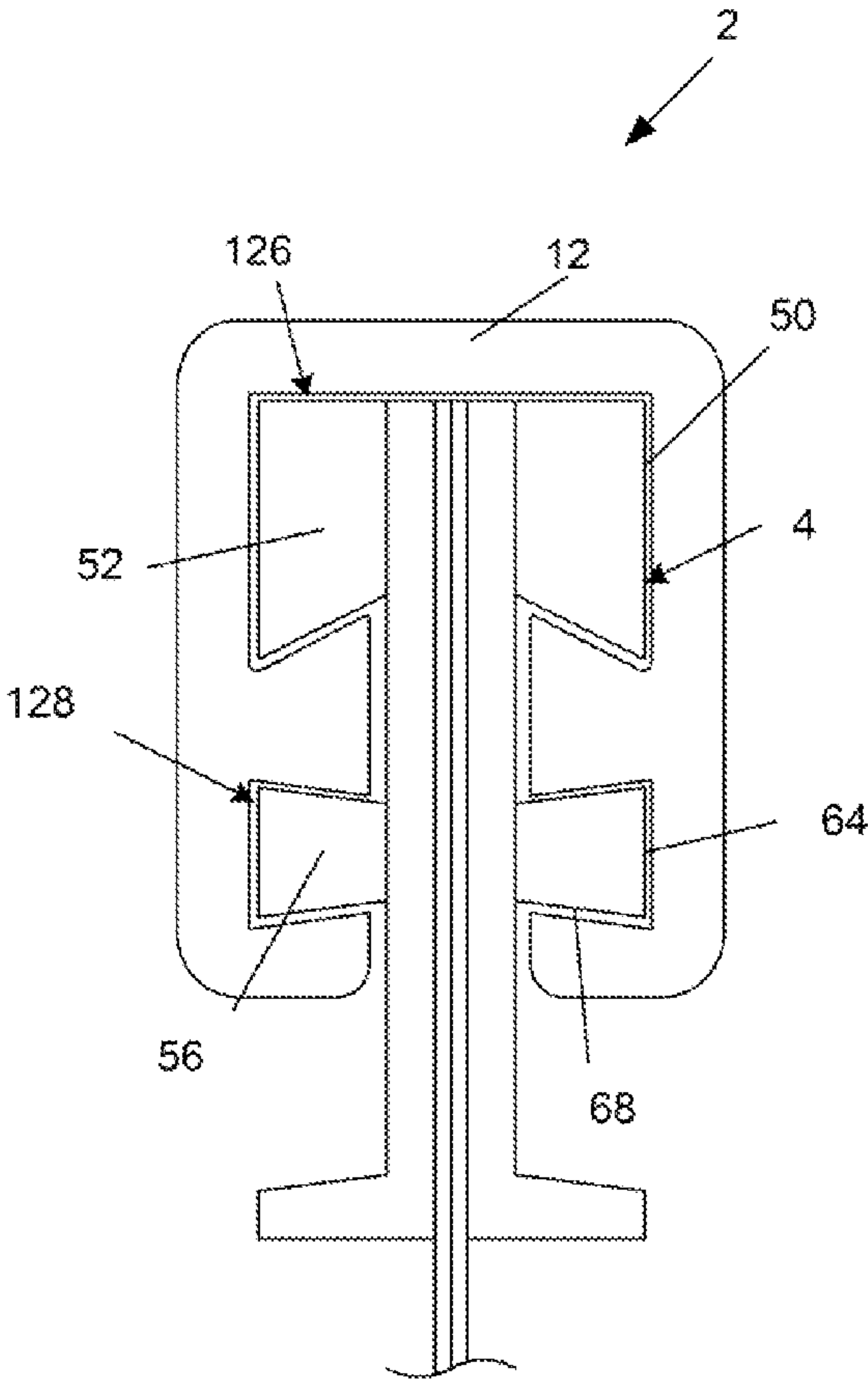

Fig. 10c

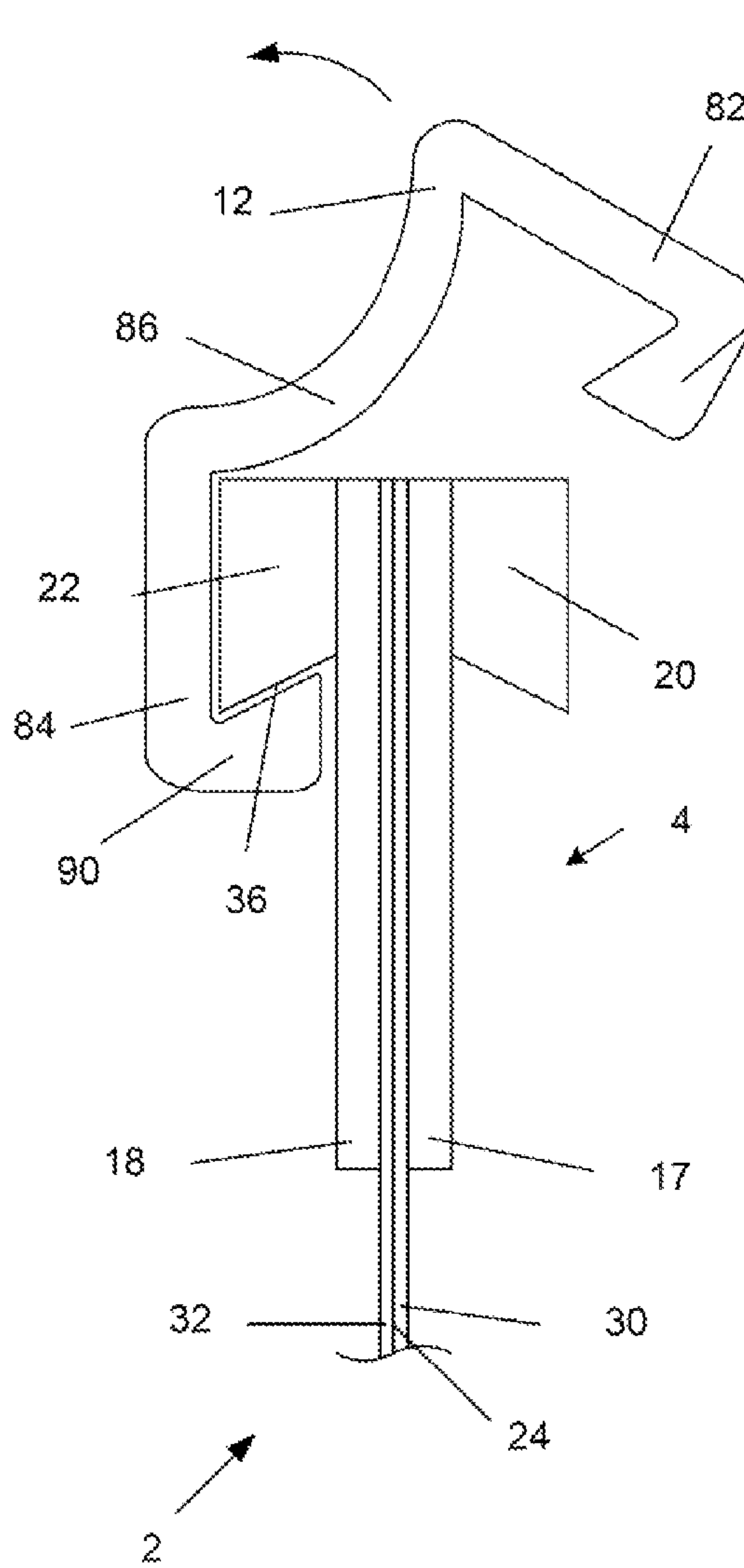

Fig. 11

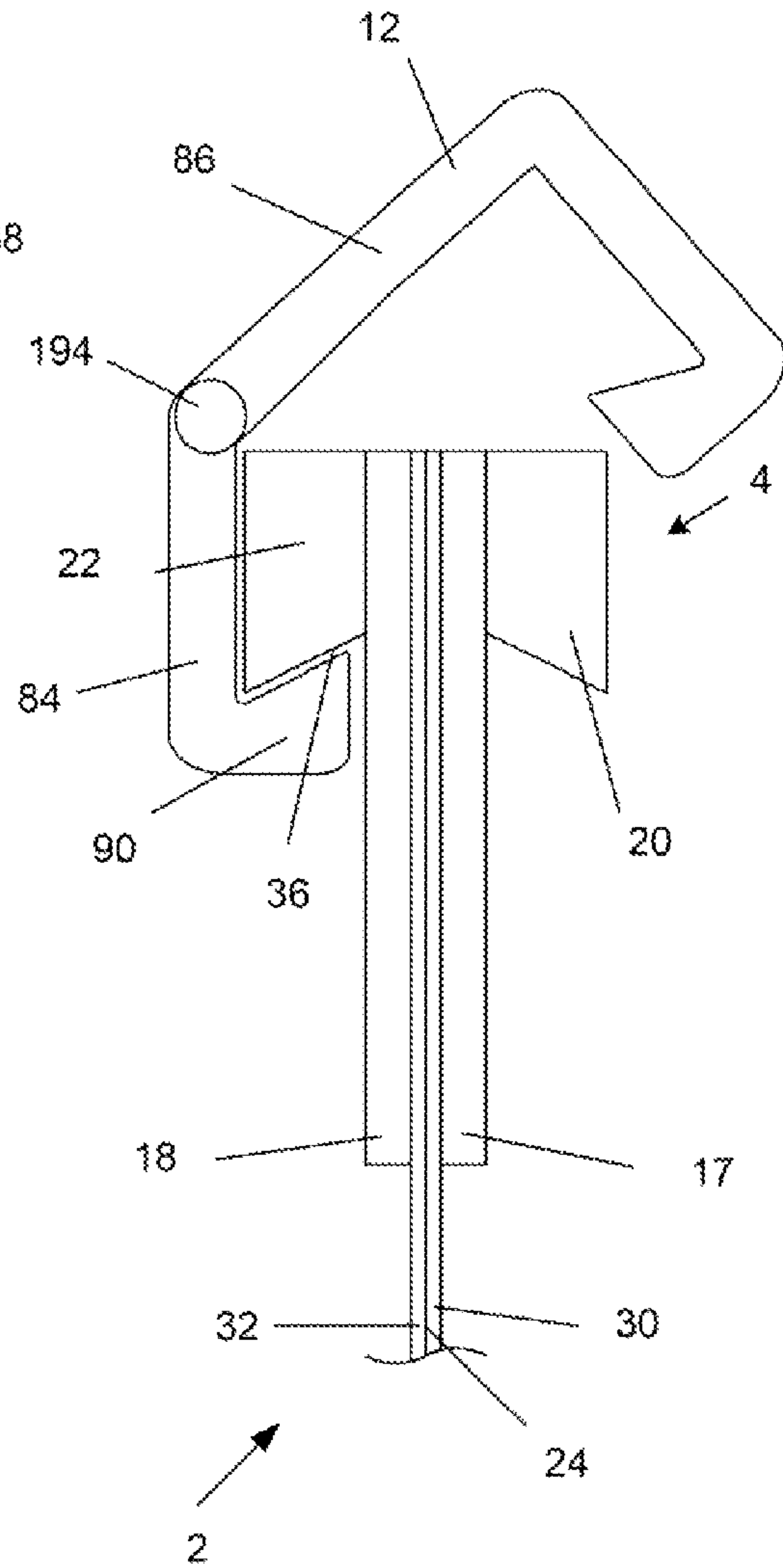

Fig. 12

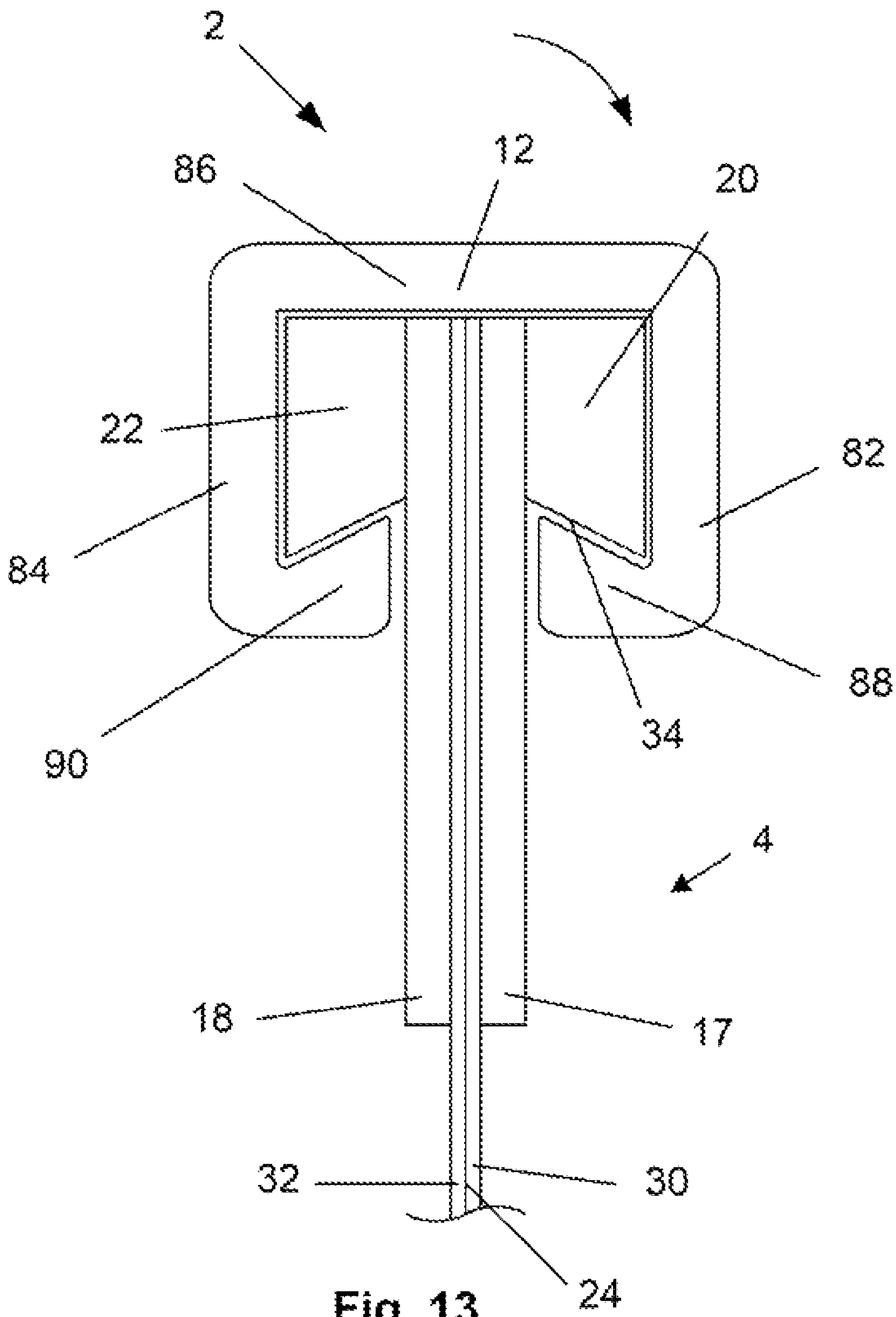

Fig. 13

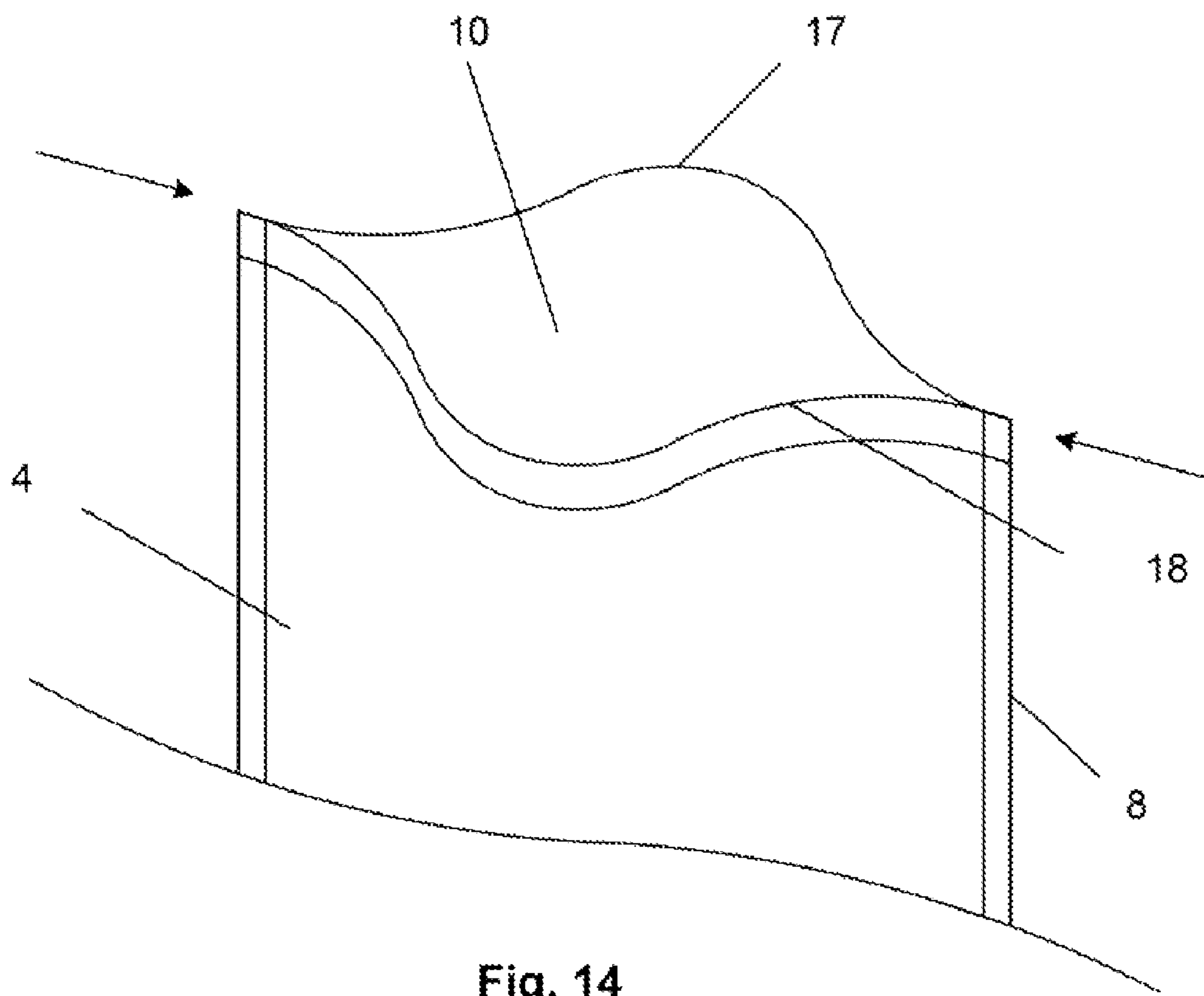

Fig. 14

1

RESERVOIR CLOSURE SYSTEM AND METHOD

CROSS-REFERENCE TO RELATED APPLICATIONS

This application is a continuation of U.S. patent application Ser. No. 11/445,721, filed Jun. 2, 2006 now U.S. Pat. No. 8,043,005, which is incorporated by reference herein in its entirety.

BACKGROUND OF THE INVENTION

1. Field of the Invention

This invention relates to the field of closeable and sealable fluid reservoirs. More specifically, this invention relates to reservoirs that can be closed and tightly and securely sealed, yet unsealed and opened rapidly.

2. Description of the Related Art

Light weight, resealable bags are used increasingly in sporting activities, such as hiking, biking, and snow sport activities like skiing and snowboarding. Limited access to the interior of typical bags makes cleaning more difficult and increases the potential for unclean and unsanitary bags. Once liquids placed in the bags are consumed, the remaining deposits encourage the growth of bacteria and mold. If left uncleaned, such growths can leave stains on the bag, may retain odors, taint any other fluids subsequently introduced into the bag, and create health risks. Regular and thorough cleaning of the inside of the reservoir is critical.

Commonly used bags for sporting are typically accessible through a relatively small side port in the bag, often covered by a removable cap. The side port limits the access to the interior of the bag, thereby limiting the ability to clean the interior of the bag.

Also, removing or adding large quantities of liquid to the typical bags is often cumbersome and messy due to the limited and constrained access to reservoir via the side port. The side ports can also limit the flow rate into and/or out of the bag, slowing the process of removing excess fluid from the bag or loading fluid into the bag.

Zipper-type closures have been developed for bags in some uses. Zipper closures allow for larger and wider openings than typical side ports, thereby allowing easy cleaning of the interior of the bags. Zipper openings also ease the process of removing and adding fluid to the bag, in speed, convenience and cleanliness. However, common zipper closures are not suitable for most sporting activities. The bags often receive forceful blows during regular use, causing large increases in fluid pressure inside the bag. Elements used to close the opening often need to be reinforced to ensure closure during use. For example, the caps on side ports are often threaded. However, zippers are often only a small portion of the length of the entire opening, leaving much of the opening exposed to rupturing upon increased reservoir fluid pressure.

Roll-top closures satisfy the above demands: reinforced openings capable of withstanding high-pressure; ease of internal reservoir cleaning; and rapid, convenient, and clean liquid addition and removal. However, some users feel that roll-top closures are cumbersome and slow to open and close.

Therefore, a closeable reservoir system is desired that is capable of ease of internal reservoir cleaning. A closeable reservoir system is also desired that can provide rapid, convenient and clean liquid addition and removal. It is also desired to have a closeable reservoir system that can with-

2

stand significantly increased fluid pressures without leaking. A closeable reservoir system is also desired that is easy and fast to open and close.

BRIEF SUMMARY OF THE INVENTION

A reservoir closure system is disclosed. The system has a container, such as a bag, and a sealing member.

The container can have a reservoir and an orifice. The orifice can have closed and open configurations. The reservoir can be in fluid communication with the orifice. The orifice can have an orifice closed length when the orifice is in the closed configuration.

The sealing member can be configured to slidably attach to the container. The sealing member can have a seal length. The seal length can be at least substantially equal to the orifice closed length. The sealing mechanism can be configured to seal the container. The sealing member can have a substantially straight configuration.

The container can have a first catch having a first catch bottom. The first catch bottom can have a first catch angle. The first catch angle can be less than about 90 degrees.

The sealing member can have one or more sealing member arms. The sealing member arms can be configured to attachably engage the catches of the container. The sealing member arms can have angled faces that correspond to angled faces on the catches. Any or all of the angles of the angled faces of the arms can be substantially equal to the angles of the angled faces of the corresponding angled faces of the catches.

The container can have a first end and a first side, and wherein the orifice is at the first end. The container can have an opening on the first side of the container. The reservoir system can have a cap removably attached to the opening. The cap can have a socket configured to attach to a tube.

The sealing member can be tethered to the container. The sealing member can be configured to be interference fit to the container.

BRIEF DESCRIPTION OF THE FIGURES

FIG. 1 illustrates an embodiment of the reservoir system.

FIG. 2 is a perspective view of an embodiment of the top of the bag.

FIGS. 3a through 3g are side views of various embodiments of the top of the bag.

FIG. 4 is a perspective view of an embodiment of the slider.

FIG. 5 is a top view of an embodiment of the slider.

FIGS. 6a through 6g are side views of various embodiments of the first end of the slider.

FIGS. 7 through 9 illustrate a sequence of an embodiment of a method of using the slider on the bag.

FIGS. 10a, 10b and 10c are side views of various embodiments of the top of the reservoir system.

FIGS. 11 and 12 illustrate various embodiments of methods of using the slider on the bag.

FIG. 13 illustrates an embodiment of the reservoir system with the slider attached to the bag.

FIG. 14 is a perspective view of an embodiment of a method of using the bag.

DETAILED DESCRIPTION

FIG. 1 illustrates that a reservoir system 2 can have a reservoir container, such as a bag 4, and a sealing member, such as an elongated slider 12. The bag 4 can have a reservoir 6, such as one or more hollows. Multiple reservoirs (not

shown) in the bag **4** can be divided into one or more separate compartments by one or more septa, bladders and/or other dividers.

The bag **4** can have a bag reinforcement **8**, such as a bag seal. The bag reinforcement **8** can strengthen one or more higher-probability mechanical failure areas on the bag **4**. The bag seal **8** can have thicker dimensions than the surrounding material. The bag seal **8** can have layers of the material of the bag **4** or a different material attached to and/or integral with the bag **4**. The bag seal **8** can be along all or part (as shown) of the circumference of the bag **4**, for example, excluding the portion of the bag adjacent to the orifice **10**.

The slider **12** and the bag can be configured to facilitate slidably translating the slider **12** on the bag. The bag can have a guide. The guide can direct the slider **12** during use.

The slider **12** can have a slider seal configured to seal the orifice **10**. The slider seal can be, for example, the location on the slider **12** where the dimensions of slider arms provide sufficient force on the bag **4** to seal the bag **4** with the slider **12** on the bag **4**. The slider seal can have a slider seal length **16**. The slider seal length **16** can be from about 5 cm (2 in.) to about 91 cm (36 in.), more narrowly from about 5 cm (2 in.) to about 46 cm (18 in.), yet more narrowly from about 17 cm (6.5 in.) to about 18 cm (7.0 in.), for example, about 17 cm (6.5 in.).

FIG. **2** illustrates that the bag **4** can have a first lip **17** (partially hidden) and second lip **18**, for example, adjacent to the orifice **10**. The first lip **17** can be opposite the second lip **18**. The lips **17**, **18** can be reinforced. The lips **17**, **18** can be thicker and/or otherwise more reinforced and/or stronger than the surrounding bag material. The first lip **17** can have one or more first engagement members, such as first catches **20**. The second lip **18** can have one or more second engagement members, such as second catches **22**.

The bag **4** can be made from a single sheet or from separate sheets, for example, integrated and/or attached at bag seams **24**. The lips **17**, **18** can have lip seams **26**. The lip seams **26** can be part of the bag seams **24**. The seams can be leak-proof and water-tight.

The orifice can have an orifice length **28**, for example in a closed configuration. The orifice length **28** can be equal to or less than the slider seal length **16**. The orifice length **28** can be from about 3.8 cm (1.5 in.) to about 90.1 cm (35.8 in.), more narrowly from about 3.8 cm (1.5 in.) to about 45.2 cm (17.8 in.), yet more narrowly from about 15 cm (6.0 in.) to about 17 cm (6.8 in.), for example, about 15 cm (6.0 in.).

The bag **4** can have an opening on either or both sides of the bag **4**. A removable cap can cover the opening. The cap can be attached by an interference or screw interface, for example. The cap can be as disclosed by U.S. patent application Ser. No. 11/445,771, filed Jun. 2, 2006, which is now abandoned, and herein incorporated by reference in its entirety.

The bag **4** can have a fitment for sealably attaching to or otherwise interfacing with, for example, one or more valves, a nozzle interface, a tube interface, a nozzle, a tube (e.g., a straw), a plug, or combinations thereof. The fitment can be a socket. The fitment can be over the opening on either or both sides of the bag **4**. The fitment can be the cap. The fitment can be or have a port or socket.

FIG. **3a** illustrates that the bag **4** can have a bag first side **30** and a bag second side **32**. The bag first side **30** can be made from at least the same or a different sheet of material from the bag second side **32**.

The first and second **20**, **22** catches can have first and second catch bottoms **34**, **36**, respectively. The first and second **20**, **22** catches can have first and second **38**, **40** catch sides, respectively. The first and second **38**, **40** catch sides can

be substantially parallel with the lip seams **26**, and/or the lips **17**, **18**, and/or the bag seam **24**, and/or the bag first side **30** and/or second side **32**. The angle formed by the catch bottom and the catch side can be a catch angle **42**. The catch angle **42** can be less than about 90°. The catch angle **42** can be from about 0° to about 90°, more narrowly from about 30° to about 80°, yet more narrowly from about 45° to about 75°, for example, about 70°.

The catches can have a catch height **44**. The catch height **44** for the first catch **20** can be the same as or different from the catch height **44** of the second catch **22**. The catch height **44** can be from about 2 mm (0.08 in.) to about 100 mm (3.9 in.), more narrowly from about 2 mm (0.08 in.) to about 30 mm (1.2 in.) for example, about 5 mm (0.2 in.).

The distance from the first catch side **38** to the second catch side **40** can be a combined catch width **46**. The combined catch width **46** can be from about 1.5 mm (0.059 in.) to about 100 mm (3.94 in.), for example, about 7 mm (0.3 in.).

The first and second lips **17**, **18** can have a combined lip width **48**. The combined lip width **48** can be from about 1.0 mm (0.039 in.) to about 100 mm (3.9 in.), for example, about 3 mm (0.1 in.).

FIGS. **3b** and **3c** illustrate that the lips **17**, **18** can have a first upper catch **50** (similar to the first catch described supra) and a second upper catch **52** (similar to the second catch described supra). The lips **17**, **18** can have a first lower catch **54** and a second lower catch **56**. The first **54** (and second **56**) lower catch can have a first **58** (and second **60**, respectively) lower catch top angle between the first **60** (and second **62**, respectively) lower catch top and the first **64** (and second **66**, respectively) lower catch side. The first **54** (and second **56**) lower catch can have a first **54** (and second **56**, respectively) lower catch bottom angle **68** between the first **64** (and second **66**, respectively) lower catch side and the first **70** (and second **72**, respectively) lower catch bottom. The lower catch angles can be about 90°. The lower catch top angles **58** can be equal or unequal to the lower catch bottom angles **68**. The lower catch top **58** and/or bottom **68** angles can be less than about 90°, for example from about 0° to about 90°, more narrowly from about 30° to about 80°, more narrowly from about 45° to about 75°, for example about 75°.

FIG. **3d** illustrates that the first **34** and/or second **36** catch bottoms can have one or more recessed interlockable elements, such as, respectively, first and/or second catch notches, recesses, slots, or grooves **74**, **76**. The catch grooves **74**, **76** can have substantially square or rectangular cross-sections. The catch grooves **74**, **76** can be extend along all or part of the length of the catch bottoms **34**, **36**. Although shown with a catch angle of 90°, the catch angle can be any catch angle disclosed herein.

FIG. **3e** illustrates that the catch grooves **74**, **76** can have substantially round (e.g., hemispherical, hemi-oval, otherwise partially spherical or oval) cross-sections. FIG. **3f** illustrates that the first and second catch grooves **74**, **76** can be immediately adjacent to the first and second lips **17**, **18**, respectively.

FIG. **3g** illustrates that the first **34** and/or second **36** catch bottoms can have one or more extending interlockable elements; such as, respectively, first and/or second catch bumps, buttons or ridges **78**, **80**. The catch ridges **78**, **80** can have substantially inverted configurations of the configurations disclosed for the catch grooves **74**, **76**.

FIG. **4** illustrates that the slider **12** can have a substantially straight longitudinal center axis **96**. The slider **12** can have a slider first side **82** and/or a slider second side **84** and a slider top **86**. The slider first side **82** and/or a slider second side **84** can extend substantially at a right angle or other non-zero

5

angle from a slider top **86**. The slider first side **82** can have a slider first arm **88**. The first and second slider arms **88, 90** can extend substantially at a right angle or other non-zero angle from the first and second slider sides **82, 84**, respectively. The ends of the slider arms **88, 90** can taper.

The slider **12** can have a first slider end **92** and/or a second slider end **94**. The slider ends **92, 94** can flare or otherwise expand radially away from the longitudinal center axis **96**. The slider ends **92, 94** can include the ends of the slider sides **82, 84**, and/or the ends of the slider arms **88, 90**, and/or the ends of the slider top **86**.

A hollow elongated slider channel **98** can be defined by the slider top **86** and/or the slider sides **82, 84** and/or the slider arms **88, 90**. The slider **12** can be flexible or rigid. The slider **12** can have one or more flexible first segments (e.g., the slider ends) and one or more rigid second segments (e.g., the remainder of the slider **12** other than the ends).

FIG. **5** illustrates that the slider **12** can have information thereon printed, embossed, otherwise marked, or combinations thereof. The information can be instructions or marketing information (e.g., branding) on the slider top **86** and/or slider sides **82, 84** and/or slider arms **88, 90**.

The slider **12** can have a slider first hole **100**, for example at the slider first end **92**. The slider **12** can have a slider second hole **102**, for example at the slider second end **94**. The slider holes **100, 102** can be on the slider top **86**.

FIG. **6a** illustrates that the slider channel **98** can have a slider channel width **104** and a slider channel height **106**. The slider channel width **104** can be from about 2 mm (0.08 in.) larger than the combined catch width **46** to about 130 mm (5 in.) larger than the combined catch width **46**, more narrowly from about 2 mm (0.08 in.) larger than the combined catch width **46** to about 5 mm (0.2 in.) larger than the combined catch width **46**, for example about 2 mm (0.08 in.) larger than the combined catch width **46**. The slider channel height **106** can be from about 2 mm (0.08 in.) larger than the catch height **44** to about 130 mm (5 in.) larger than the catch height **44**, for example about 2 mm (0.08 in.) larger than the catch height **44**.

The slider **12** can have a slider gap **108**. The slider gap **108** can be defined between the slider first arm **88** and the slider second arm **90**. The slider gap **108** can have a slider gap width **110**. The slider gap width **110** can be the distance from the slider first arm **88** to the slider second arm **90**. The slider gap width **110** can be from about 10 mm (0.4 in.) smaller than the combined lip width **48** to about 10 mm (0.4 in.) larger than the combined lip width **48**, more narrowly from about than the combined lip width **48** to about 5 mm (0.2 in.) smaller than the combined lip width **48**, yet more narrowly from about 1 mm (0.04 in.) smaller than the combined lip width **48** to about 5 mm (0.2 in.) smaller than the combined lip width **48**, for example about 5 mm (0.2 in.) smaller than the combined lip width **48**.

The slider first and second arms **88, 90** can have slider first and second arm tops **112, 114**, respectively. The slider **12** can have one or more slider arm angles **116**. The slider arm angles **116** can be the angle from the first slider arm top **112** to the slider first side **82** and/or from the second slider arm top **114** to the slider second side **84**. The slider arm angles **116** can be the same or different on each side of the slider **12** (i.e., on the slider first side **82** and the slider second side **84**). The slider arm angles **116** can be in the same ranges and the example provided, supra, for the catch angle. The slider arm angles **116** can be equal to the corresponding catch angles.

FIG. **6b** illustrates that the slider **12** can have upper arms (e.g., a slider first upper arm **118** and a slider second upper arm **120**) and lower arms (e.g., a slider first lower arm **122** and a slider second lower arm **124**). The slider **12** can have a slider

6

upper channel **126**. The slider upper channel **126** can be defined by the slider top **86**, the slider first side **82**, the slider second side **84**, and the slider upper arms **118, 120**. The slider **12** can have a slider lower channel **128**. The slider lower channel **128** can be defined by the slider first side **82**, the slider second side **84**, the slider upper arms **118, 120**, and the slider lower arms **122, 124**.

The slider upper channel **126** can have a slider upper channel height **130** and a slider upper channel width **132**. The slider lower channel **128** can have a slider lower channel height **134** and a slider lower channel width **136**.

The slider upper channel width **132** and the slider lower channel width **136** can be from about 10 mm (0.4 in.) smaller than the combined catch width **46** to about 10 mm (0.4 in.) larger than the combined catch width **46**, more narrowly from about than the combined catch width **46** to about 5 mm (0.2 in.) smaller than the combined catch width **46**, yet more narrowly from about 1 mm (0.04 in.) smaller than the combined catch width **46** to about 5 mm (0.2 in.) smaller than the combined catch width **46**, for example about 5 mm (0.2 in.) smaller than the combined catch width **46**. The slider upper channel width **132** can be the same as or different than the slider lower channel width **136**.

The slider upper channel height **130** and the slider lower channel height **134** can be from about 10 mm (0.4 in.) smaller than the upper or lower catch height to about 10 mm (0.4 in.) larger than the upper or lower catch height, more narrowly from about 5 mm (0.2 in.) smaller than the upper or lower catch height to about 5 mm (0.2 in.) larger than the upper or lower catch height, for example about 2 mm (0.08 in.) larger than the upper or lower catch height. The slider upper channel height **130** can be the same as or different than the slider lower channel height **134**.

The slider **12** can have a slider upper gap **138**. The slider upper gap **138** can be defined between the slider first upper arm **118** and the slider second upper arm **120**. The slider upper gap **138** can have a slider upper gap width **140**. The slider **12** can have a slider lower gap. The slider lower gap **142** can be defined between the slider first lower arm **122** and the slider second lower arm **124**. The slider lower gap **142** can have a slider lower gap width **144**.

The slider upper gap width **140** and the slider lower gap width **144** can be the distance from the slider first upper arm **118** to the slider second upper arm **120**. The slider upper gap width **140** can be from about 10 mm (0.4 in.) smaller than the combined lip width **48** to about 10 mm (0.4 in.) larger than the combined lip width **48**, more narrowly from about than the combined lip width **48** to about 5 mm (0.2 in.) smaller than the combined lip width **48**, yet more narrowly from about 1 mm (0.04 in.) smaller than the combined lip width **48** to about 5 mm (0.2 in.) smaller than the combined lip width **48**, for example about 5 mm (0.2 in.) smaller than the combined lip width **48**. The slider upper gap width **140** can be the same as or different than the slider lower gap width **144**.

FIG. **6c** illustrates that the slider upper and/or lower arms **118, 120** can have dovetail or other flared configurations. The slider first and second upper arms **118, 120** can have slider first and second upper arm tops **146, 148**, respectively. Slider first and second upper arm top angles **150, 152** can be defined between the slider first and second upper arm tops **146, 148**, and the slider first and second sides **82, 84**, respectively (as shown).

The slider first and second upper arm top angles **150, 152** can be selected from the range or example provided herein for the upper catch angle **44**. The slider first and second arm top angles **150, 152** can be greater than, less than, or equal to the upper catch angle **44**.

The slider upper arms **118, 120** can have slider upper arm bottoms **158, 160**. Slider first and second upper arm bottom angles **154, 156** can be defined between the slider first and second upper arm bottoms **158, 160**, and the slider first and second sides **82, 84**, respectively (as shown).

The slider first and second arm bottom angles **154, 156** can be selected from the range or example provided herein for the lower catch top angle **58**. The slider first and second arm bottom angles **154, 156** can be greater than, less than, or equal to the lower catch top angle **58**.

Slider first and second lower arm top angles **162, 164** can be defined between the slider first and second lower arm tops **166, 168**, and the slider first and second sides **82, 84**, respectively (as shown). The slider first and second lower arm angles **170, 172** can be selected from the range or example provided herein for the lower catch bottom angle **68**. The slider first and second lower arm angles **170, 172** can be greater than, less than, or equal to the lower catch bottom angle **68**.

FIG. **6d** illustrates that the slider first and/or second arms **88, 90** can have one or more extended interlockable elements, such as, respectively, first and/or second arm bumps, buttons or ridges **174, 176**. The arm ridges **174, 176** can have substantially square or rectangular cross-sections. The arm ridges **174, 176** can extend along all or part of the length of the catch bottoms. Although shown with a catch angle of 90°, the catch angle can be any catch angle disclosed herein.

FIG. **6e** illustrates that the arm ridges **174, 176** can have substantially round (e.g., hemispherical, hemi-oval, otherwise partially spherical or oval) cross-sections. FIG. **6f** illustrates that the first and second arm ridges **174, 176** can be immediately adjacent to the slider gap **108**.

FIG. **6g** illustrates that the first **88** and/or second **90** slider arms can have one or more recessed interlockable elements, such as, respectively, first and/or second arm notches, recesses, slots, or grooves **178, 180**. The arm grooves **178, 180** can have substantially inverted configurations of the configurations disclosed for the arm ridges **174, 176**.

The catch grooves **74, 76** can be configured to interference fit with the arm ridges. The catch ridges **78, 80** can be configured to interference fit with the arm grooves **178, 180**.

The bag **4** can be configured similar to and/or have any elements and/or configurations of the bag disclosed in U.S. Pat. No. **6,267,506**, which is herein incorporated by reference in its entirety. If the top of the bag **4** is rolled in a closed configuration, as shown in U.S. Pat. No. **6,267,506**, the bag can be configured, when in the rolled configuration, to form substantially similar configurations to the first **20** and/or second catches **22**. The first and/or second catches **20, 22** can be formed by the splint(s) and/or fold(s) and/or flap(s) and/or other components disclosed in U.S. Pat. No. **6,267,506**.

The bag, slider, and any and all other elements described herein can be made from polyethylene, such as high density polyethylene (HDPE) or low density polyethylene (LDPE) (e.g., linear LDPE), polytetrafluoroethylene (PTFE), polyurethane (e.g., thermoplastic polyurethane (TPU)), polyvinyl chloride (PVC), thermoplastic elastomer (TPE), polyoxymethylene (POM), also known as acetal resin, polytrioxane and polyformaldehyde (e.g., DELRIN® by E.I. DU PONT DE NEMOURS AND COMPANY™, Wilmington, Del.), Nylon, or combinations thereof. For example, the slider can be made from POM and the bag can be made from TPU.

Method of Making

The bag **4** can be molded and/or any and/or all of the elements of the bag **4** can be welded (e.g., RF welded)

together. The slider **12** can be molded and/or any and/or all of the elements of the slider **12** can be welded (e.g., RF welded) together.

Methods of Use

FIG. **7** illustrates that before sealably closing the orifice **10**, the slider **12** can be unattached to the bag **4**. The slider **12** can be aligned to the top of the bag **4**. The slider channel **98** can be substantially longitudinally aligned with the first and second catches **20, 22**.

FIG. **8** illustrates that the slider **12** can be translated relative to the bag **4**, as shown by arrow. The slider **12** can be slidably attached to the bag **4**. The slider **12** can be translated in the direction of the longitudinal center axis. The guides **14, 15**, lips **17, 18**, and catches **20, 22** can direct the slider arms **88, 90** longitudinally along the top of the bag **4**. The tapered configuration of the slider arms **88, 90** can direct the slider arms **88, 90** longitudinally along the top of the bag **4**. The slider arms **88, 90** can force the first lip **17** toward the second lip **18**. The slider sides **82, 84** can force the first catch **20** toward the second catch **22**.

The slider **12** can be unattached from the bag **4** by translating the slider **12** in the direction relative to the bag **4** opposite that shown by the arrow in FIG. **8**.

FIG. **9** illustrates that the reservoir system **2** can be in a sealed configuration. The slider **12** can be slidably attached and friction fit to the top of the bag **4**. The slider **12** can provide pressure squeezing the orifice **10** closed.

FIG. **10a** illustrates that when the slider **12** is attached to the top of the bag **4**, the slider **12** can sealably close the orifice **10**. The slider **12** can apply pressure on the bag **4** at any combination of the following areas: where the slider top **86** contacts the lips **17, 18** and/or the catch **20, 22**; where the catches **20, 22** contact the slider sides **82, 84**; where the slider arms **88, 90** contact the catches **20, 22**, where the slider arms **88, 90** contact the lips **17, 18**, and where the arms **88, 90** contact the guides **14, 15**.

The reservoir system **2** can have side-catch gaps **182** between the slider sides **82, 84** and the corresponding catches **20, 22**. The reservoir system **2** can have a top-catch gap between the slider top **86** and the catches **20, 22** and/or lips **17, 18**. The reservoir system **2** can have arm-catch gaps **186** between the slider arms **88, 90** and the corresponding catches **20, 22**. The reservoir system **2** can have arm-lip gaps **188** between the slider arms **88, 90** and the corresponding lips **17, 18**. With the slider **12** deployed to sealably close the bag **4**, the side-catch gaps **182**, top-catch gap **184**, arm-catch gaps **186**, and arm-lip gaps **188** can be from about 0 mm (0 in.) to about 10 mm (0.4 in.), for example about 0 mm (0 in.).

The slider arms **88, 90** can produce an arm compression force **190**, shown by arrows, against the first and second lips **17, 18**. The slider sides **82, 84** can produce a side compression force **192**, shown by arrows, against the first and second catches **20, 22**. The arm **190** and/or side **192** compression forces can minimize and/or prevent fluid leakage from the reservoir **6** out of the orifice **10**.

When pressure in the bag **4** increases (e.g., when the bag **4** contains fluid and the bag **4** is squeezed), the first and/or second catches **20, 22** can impair the movement of the slider first and/or second arms **88, 90**, respectively, in an upward direction (with respect to the page of FIG. **10a**), for example retaining the slider **12** on the bag **4**.

FIG. **10b** illustrates that the slider **12** of FIG. **6b** is configured to sealably close the bag **4** of FIG. **3b**. The upper catches **50, 52** can be configured to engage and slidably attach to the slider upper channel **126**. The lower catches **54, 56** can be configured to engage and slidably attach to the slider lower

channel 128. FIG. 10c illustrates that the slider 12 of FIG. 6c is configured to sealably close the bag 4 of FIG. 3c.

The slider gaps 108, slider upper gaps 138 and slider lower gaps 142 can be configured to engage and slidably attach to the lips 17, 18.

The bags 4 illustrated in FIGS. 3d through 3g can be used with sliders 12 illustrated in FIGS. 6d through 6g, respectively. During use, the catch grooves 74, 76 can interference fit with the arm ridges 174, 176. During use, the catch ridges 78, 80 can interference fit with the arm grooves 178, 180.

FIG. 11 illustrates that the slider top 86 can be resiliently or deformably bendable. The slider top 86 can be rotatably bent, as shown by arrow. The slider second arm 90 can be fixedly attached and/or engaged to the second catch bottom 36. The slider second side 84 can be positioned directly adjacent to the second catch 22. The slider first side 82 and slider first arm 88 can be unattached to and/or disengaged from the first catch 20.

FIG. 12 illustrates that the slider 12 can have one or more rotatable elements, for example hinges or joints. The joint 194 can be at the intersection of the slider top 86 and the slider first 82 and/or second 84 side. The joint 194 can enable the slider top 86 to rotate with respect to the slider first 82 and/or second 84 side. The joint 194 can be fixable (e.g., lockable), for example when the slider top 86 is at a right angle with respect to the slider first 82 and/or second 84 side. The joint 194 can be passive and/or biased to force the slider top 86 to a right angle with respect to the slider first 82 and/or second 84 side.

FIG. 13 illustrates that the slider 12 of FIGS. 11 and 12 can be released and/or forcibly rotated, as shown by arrow. The slider first arm 88 can snap onto the first catch 20, fixedly attaching to the first catch bottom 34 and/or producing the arm compression force 190. The slider first side 82 can be directly adjacent to the first catch and/or producing the side compression force 192.

FIG. 14 illustrates that the orifice 10 can be opened when the slider 12 is not engaged to seal the orifice 10. Compressive forces, as shown by arrows, can be applied to the ends of the lips 17, 18. Tensile forces, not shown (but perpendicular to the shown compressive forces), can be applied to the sides of the lips 17, 18. The first lip 17 can separate from the second lip 18. The lips 17, 18 can open in a puckered configuration. During use, solids and/or fluids (e.g., potable water, other beverages) can be transferred into and/or out of the bag 4 from the open orifice 10. The flexible bag 4 can be turned inside out through the orifice 10, for example, to aid access and cleaning the inside of the bag 4. The lips 17, 18 can be configured to be resiliently biased to close.

The slider 12 can be attached to the bag 4. For example, a leash can attach the slider 12 to the bag 4. The leash can be attached to the first and/or second hole. Also for example, the slider 12 and/or bag 4 can have a catch configured so the slider 12 can not be completely slidably removed from the bag 4.

It is apparent to one skilled in the art that various changes and modifications can be made to this disclosure, and equivalents employed, without departing from the spirit and scope of the invention. Elements of systems, devices and methods shown with any embodiment are exemplary for the specific embodiment and can be used in combination or otherwise on other embodiments within this disclosure.

We claim:

1. A reservoir closure system comprising:

a container wherein the container comprises a first end, the first end having a first lip, a first catch, a second lip, a second catch, a flexible, semi-rigid elongated splint, a reservoir and an orifice at the first end having a closed configuration and an opened configuration, wherein the

reservoir is in fluid communication with the orifice, and wherein the orifice has an orifice closed length about the width of the first end of the container when the orifice is in the closed configuration, and wherein the container comprises a fold coincident with the upper edge of the splint;

a sealing member configured to slidably attach to the container, and wherein the sealing member has a seal length, and wherein the seal length is at least substantially equal to the orifice closed length, and wherein the sealing member is configured to seal the container, and wherein the sealing member has a substantially straight configuration;

wherein the sealing member comprises a channel defined by a sealing member first side, a sealing member second side, and a first upper arm and a first lower arm extending from the sealing member first side and positioned opposite a second upper arm and a second lower arm extending from the sealing member second side; and

wherein the sealing member first side is rigidly integral with the sealing member second side; and

wherein the sealing member has a sealing member longitudinal axis, a sealing member first end and a sealing member second end, and wherein the shape of the sealing member first end radially expands away from the sealing member longitudinal axis as the length along the sealing member first end approaches the terminus of the sealing member; and

wherein the sealing member first side is at a fixed width away from the sealing member second side when the system is in a first configuration when the sealing member is separate from the container and when the system is in a second configuration when the sealing member is attached to the container and induces sealing of the container; and

wherein the channel is configured to receive the first and second catches of the container as the sealing member is slidably attached to the container such that first and second arms compress the first and second lips above the first and second catches, and the first and second catches prevent substantial movement of the sealing member in a vertical direction relative to the container.

2. The system of claim 1, wherein at least one cross-sectional side of the splint has a rounded configuration.

3. The system of claim 1, wherein at least one cross-sectional side of the splint has a flat configuration.

4. The system of claim 1, wherein a cross-section of the splint perpendicular to the longitudinal length of the splint has a first side, a second side, a third side and a fourth side, wherein the first side has a flat length, and wherein the second side has a flat length, and wherein the third side has a flat length, and wherein the fourth side has a rounded length.

5. The system of claim 1, wherein the container is sufficiently flexible to be turned inside out.

6. The system of claim 1, wherein the container further comprises a neck reinforcement.

7. The system of claim 1, wherein when the system is in a folded configuration, the splint is between the first lip and the second lip.

8. The system of claim 1, wherein in a first configuration the splint is positioned on a first side of the reservoir, and wherein in a second configuration the splint is positioned between the first lip and the first side of the reservoir.

9. The system of claim 1, wherein the splint has a physical memory which urges the splint to return to a linear position after being flexed.

11

10. A reservoir closure system comprising:

a container wherein the container comprises a first end, the first end having a first lip, a second lip, a reservoir and an orifice at the first end having a closed configuration and an opened configuration, wherein the reservoir is in fluid communication with the orifice, and wherein the orifice has an orifice closed length about the width of the first end of the container when the orifice is in the closed configuration, and wherein the container comprises a fold configured to concurrently fold the first lip and the second lip; and

wherein the container has an open configuration and a closed configuration, and wherein when the container is in the open configuration the container has at least two catches on a first side of the container and the fold is in an unfolded configuration, and wherein when the container is in a closed configuration the container has at least one catch on the first side of the container and at least one catch on the second side of the container and the fold is in a folded configuration further comprising a sealing member configured to slidably attach to the container, and wherein the sealing member has a seal length, and wherein the seal length is at least substantially equal to the orifice closed length, and wherein the sealing member is configured to seal the container, and wherein the sealing member has a substantially straight configuration;

wherein the sealing member comprises a channel defined by a sealing member first side, a sealing member second side, and a first upper arm and a first lower arm extending from the sealing member first side and positioned opposite a second upper arm and a second lower arm extending from the sealing member second side; and

wherein the sealing member first side is rigidly integral with the sealing member second side; and wherein the sealing member has a sealing member longitudinal axis, a sealing member first end and a sealing member second end, and wherein the shape of the sealing member first end radially expands away from the sealing member longitudinal axis as the length along the sealing member first end approaches the terminus of the sealing member; and

wherein the sealing member first side is at a fixed width away from the sealing member second side when the system is in a first configuration when the sealing member is separate from the container and when the system is in a second configuration when the sealing member is attached to the container and induces sealing of the container.

11. The system of claim **10**, wherein the at least two catches extend laterally from the first side of the container when the container is in an opened configuration.

12. The system of claim **10**, wherein the at least one catch extends laterally from the second side of the container when the container is in a closed configuration.

13. The system of claim **10**, wherein the at least two catches are positioned on the first side of the container so one of the at least two catches is higher along the first side than the other of the at least two catches.

14. The system of claim **10**, further comprising a flexible, semi-rigid elongated splint wherein the container comprises a fold coincident with the upper edge of the splint.

15. A reservoir closure system comprising:

a container wherein the container comprises a first end, the first end having a first lip, a second lip, a flexible, an elongated splint, a reservoir and an orifice at the first end having a closed configuration and an opened configura-

12

tion, wherein the reservoir is in fluid communication with the orifice, and wherein the orifice has an orifice closed length about the width of the first end of the container when the orifice is in the closed configuration, and wherein the container comprises a fold coincident with the upper edge of the splint;

a sealing member configured to slidably attach to the container, and wherein the sealing member has a seal length, and wherein the seal length is at least substantially equal to the orifice closed length, and wherein the sealing member is configured to seal the container, and wherein the sealing member has a substantially straight configuration;

wherein the sealing member comprises a channel defined by a sealing member first side, a sealing member second side, and a first upper arm and a first lower arm extending from the sealing member first side and positioned opposite a second upper arm and a second lower arm extending from the sealing member second side; and

wherein the sealing member first side is rigidly integral with the sealing member second side; and

wherein the sealing member has a sealing member longitudinal axis, a sealing member first terminal end at a first end of the sealing member longitudinal axis and a sealing member second terminal end at a second end of the sealing member longitudinal axis, and wherein the first terminal end of the sealing member is configured to slide onto the container; and

wherein the sealing member first side is at a fixed width away from the sealing member second side when the system is in a first configuration when the sealing member is separate from the container and when the system is in a second configuration when the sealing member is attached to the container and induces sealing of the container; and

and wherein a cross-section of the splint perpendicular to the longitudinal length of the splint has a first side, a second side, a third side and a fourth side, wherein the first side has a flat length, and wherein the second side has a flat length, and wherein the third side has a flat length, and wherein the fourth side has a rounded length.

16. A reservoir closure system comprising:

a container wherein the container comprises a first end, the first end having a first lip, a second lip, a flexible, an elongated splint, a neck reinforcement, a reservoir and an orifice at the first end having a closed configuration and an opened configuration, wherein the reservoir is in fluid communication with the orifice, and wherein the orifice has an orifice closed length about the width of the first end of the container when the orifice is in the closed configuration, and wherein the container comprises a fold coincident with the upper edge of the splint;

a sealing member configured to slidably attach to the container, and wherein the sealing member has a seal length, and wherein the seal length is at least substantially equal to the orifice closed length, and wherein the sealing member is configured to seal the container, and wherein the sealing member has a substantially straight configuration;

wherein the sealing member comprises a channel defined by a sealing member first side, a sealing member second side, and a first upper arm and a first lower arm extending from the sealing member first side and positioned opposite a second upper arm and a second lower arm extending from the sealing member second side; and

13

wherein the sealing member first side is rigidly integral with the sealing member second side; and

wherein the sealing member has a sealing member longitudinal axis, a sealing member first terminal end at a first end of the sealing member longitudinal axis and a sealing member second terminal end at a second end of the sealing member longitudinal axis, and wherein the first terminal end of the sealing member is configured to slide onto the container; and

14

wherein the sealing member first side is at a fixed width away from the sealing member second side when the system is in a first configuration when the sealing member is separate from the container and when the system is in a second configuration when the sealing member is attached to the container and induces sealing of the container.

* * * * *

UNITED STATES PATENT AND TRADEMARK OFFICE
CERTIFICATE OF CORRECTION

PATENT NO. : 8,186,881 B2
APPLICATION NO. : 13/237165
DATED : May 29, 2012
INVENTOR(S) : Matthew J. Lyon et al.

Page 1 of 1

It is certified that error appears in the above-identified patent and that said Letters Patent is hereby corrected as shown below:

In the Claims

Column 10 In Claim 1, Line 39, please replace “that first” with --that the first--

Column 10 In Claim 5, Line 55, please replace “he turned” with --be turned--

Column 11 In Claim 10, Line 20, please replace “configuration further comprising” with
--configuration;
further comprising--

Column 11 In Claim 10, Line 37, please replace “scaling member” with --sealing member--

Column 11 In Claim 15, Line 65-66, please replace “flexible, an elongated” with --flexible
elongated--

Column 12 In Claim 16, Line 46-47, please replace “flexible, an elongated” with --flexible
elongated--

Signed and Sealed this
Seventh Day of May, 2019

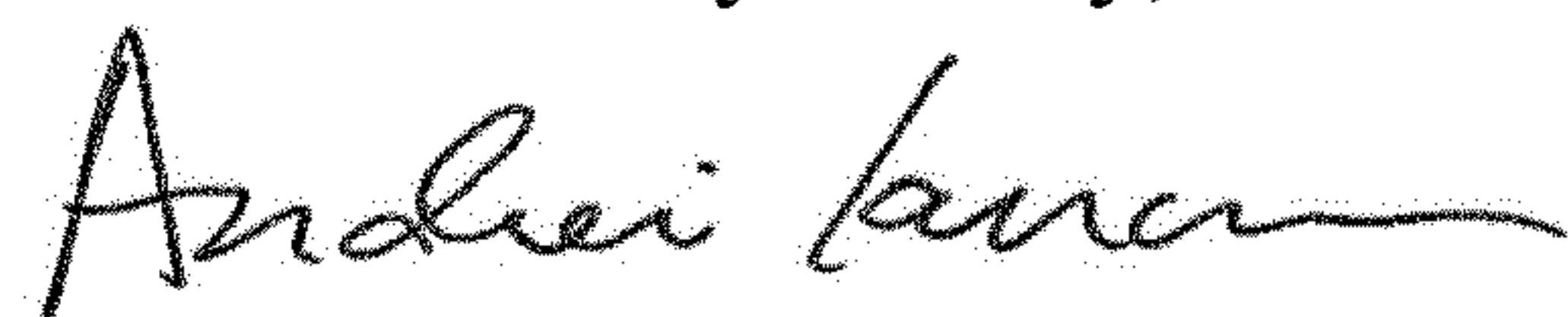

Andrei Iancu
Director of the United States Patent and Trademark Office