



US008186507B2

(12) **United States Patent**
Kagen

(10) **Patent No.:** **US 8,186,507 B2**
(45) **Date of Patent:** ***May 29, 2012**

(54) **STAND GOLF BAG WITH MECHANISM TO SECURE CLUBS**

(56) **References Cited**

(76) Inventor: **Alan M. Kagen**, Pooler, GA (US)

U.S. PATENT DOCUMENTS

(*) Notice: Subject to any disclaimer, the term of this patent is extended or adjusted under 35 U.S.C. 154(b) by 4 days.

This patent is subject to a terminal disclaimer.

1,570,500	A *	1/1926	Kennedy	206/315.6
1,719,360	A	7/1929	Deike		
2,722,431	A	11/1955	Victor		
3,265,106	A	8/1966	Jarman		
4,148,496	A	4/1979	Zimmer		
4,753,446	A	6/1988	Mills		
4,834,235	A	5/1989	Solheim et al.		
5,029,703	A	7/1991	Dulyea, Sr.		
5,459,960	A *	10/1995	Manlove	47/65.5
5,469,960	A *	11/1995	Yuill	206/315.3
5,857,567	A	1/1999	Cheng		
6,006,904	A	12/1999	Jacobsen		
6,352,154	B1 *	3/2002	Miura	206/315.6
6,862,906	B2	3/2005	Lindkjølen		
7,025,202	B2	4/2006	Jansen et al.		
7,281,398	B1	10/2007	Sims		
2001/0017272	A1	8/2001	Thompson et al.		

(21) Appl. No.: **12/820,238**

(22) Filed: **Jun. 22, 2010**

(65) **Prior Publication Data**

US 2010/0252466 A1 Oct. 7, 2010

Related U.S. Application Data

(63) Continuation of application No. 12/044,449, filed on Mar. 7, 2008, now Pat. No. 7,775,353.

(60) Provisional application No. 60/893,406, filed on Mar. 7, 2007.

(51) **Int. Cl.**
B62B 3/12 (2006.01)

(52) **U.S. Cl.** **206/315.6**; 206/315.1; 206/315.2;
206/315.3; 280/47.26; 280/62; 211/70.2;
70/58

(58) **Field of Classification Search** 206/315.1,
206/315.2, 315.6, 315.3

See application file for complete search history.

* cited by examiner

Primary Examiner — Anthony Stashick

Assistant Examiner — Cynthia Collado

(74) *Attorney, Agent, or Firm* — Nixon & Vanderhye P.C.

(57) **ABSTRACT**

A mechanism cooperable with the stand mechanism in a stand golf bag secures the clubs in position when the bag is not on the ground and releases the clubs when the bag is set on the ground.

4 Claims, 3 Drawing Sheets

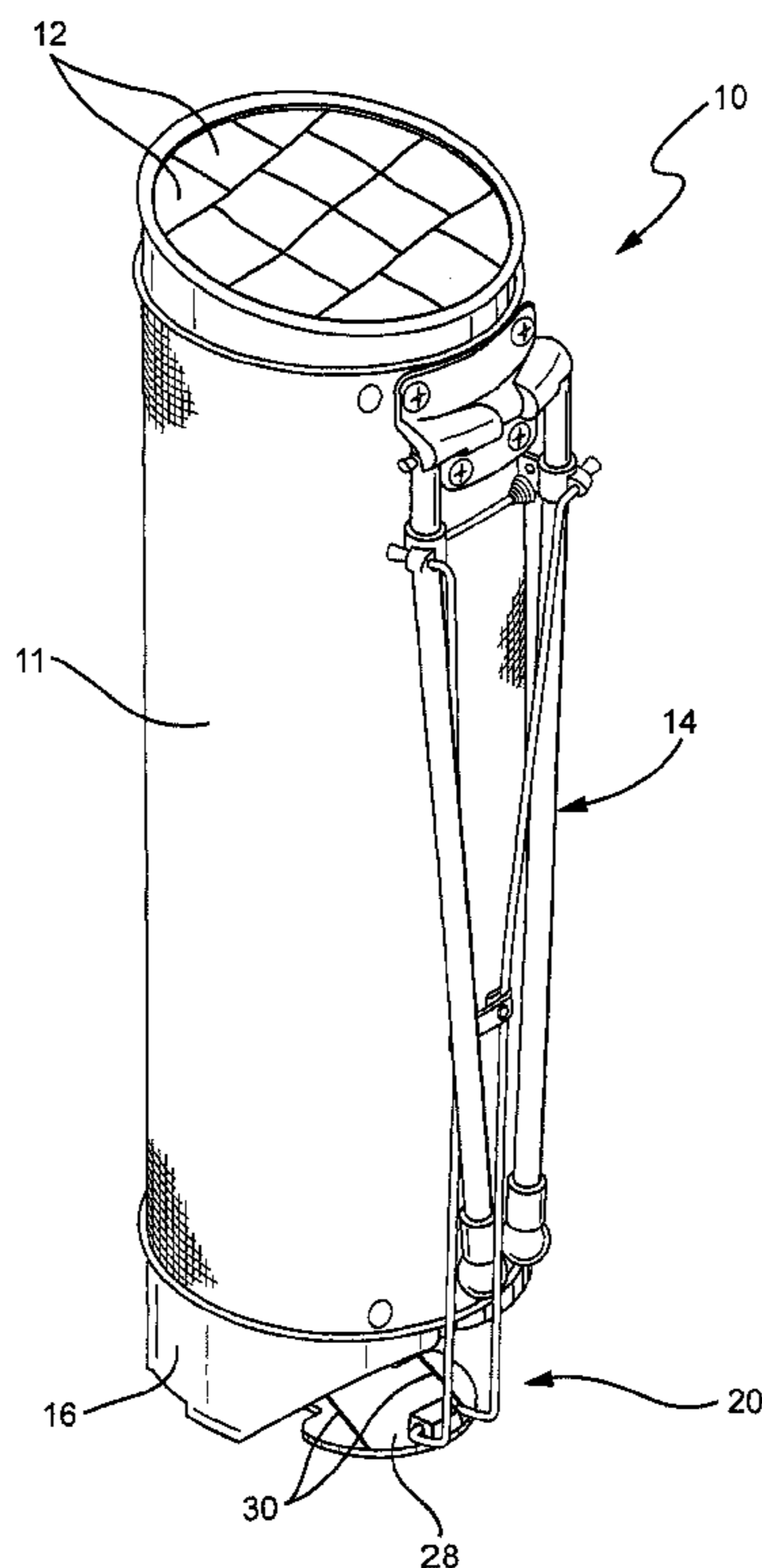

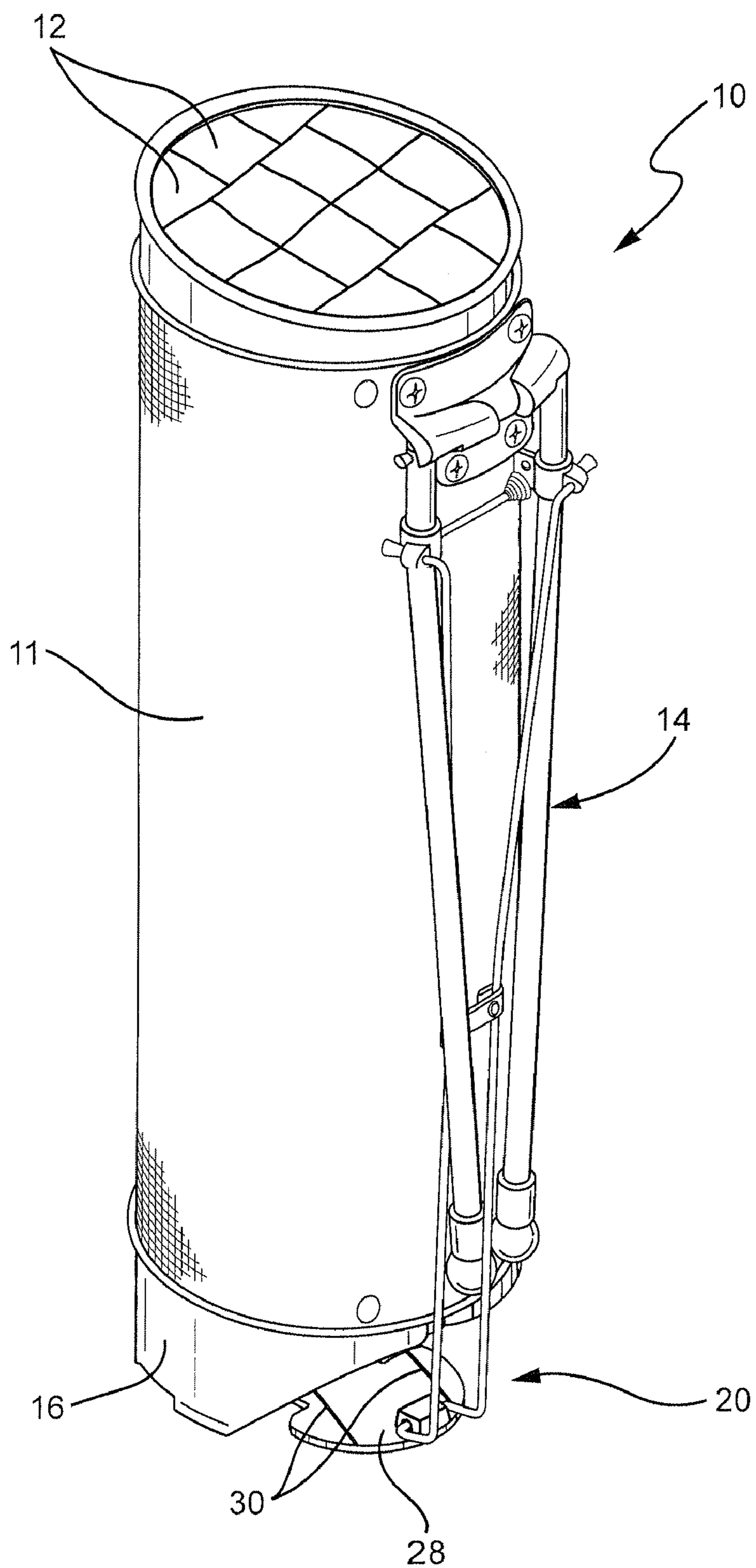

FIG. 1

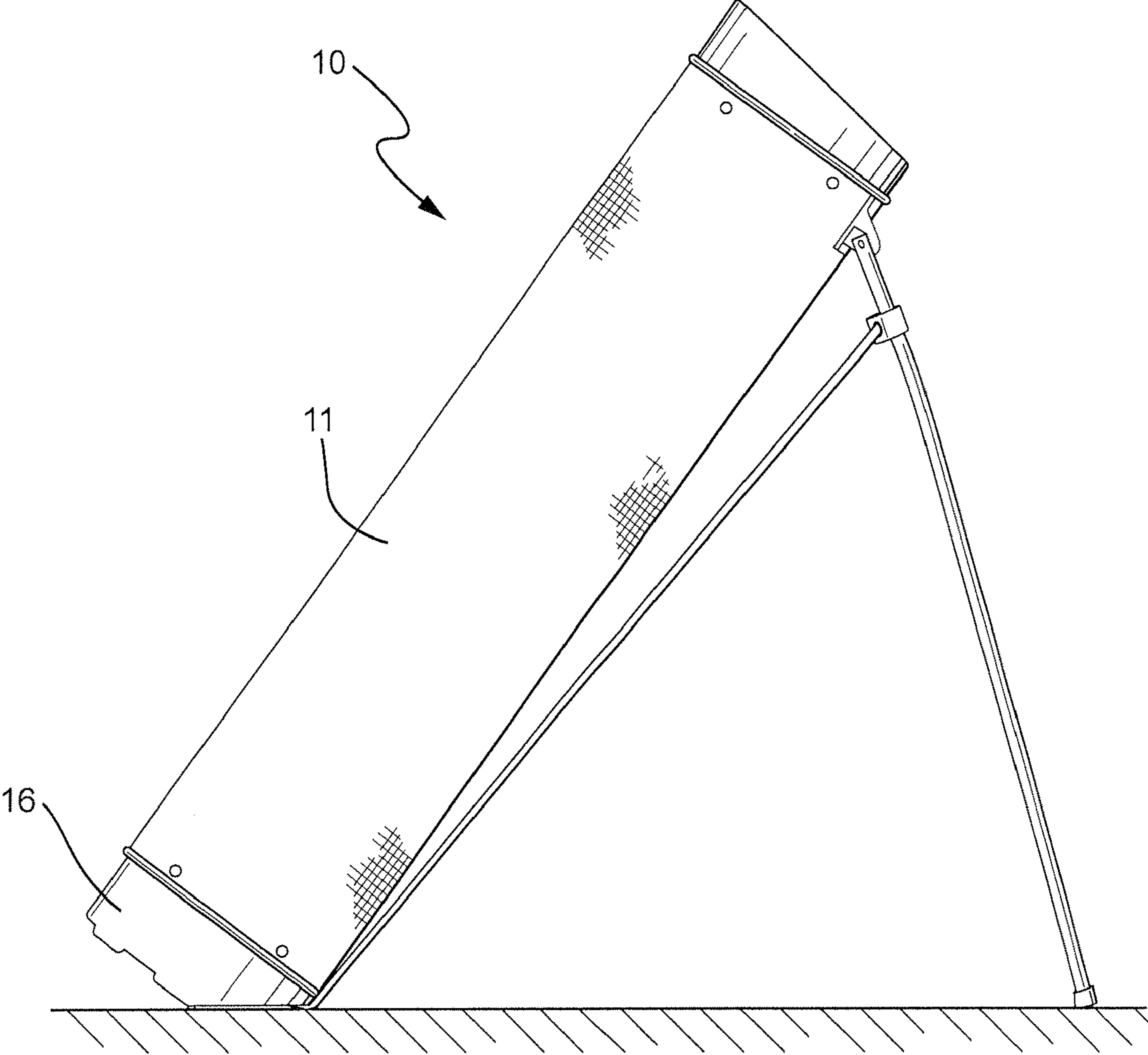

FIG. 2

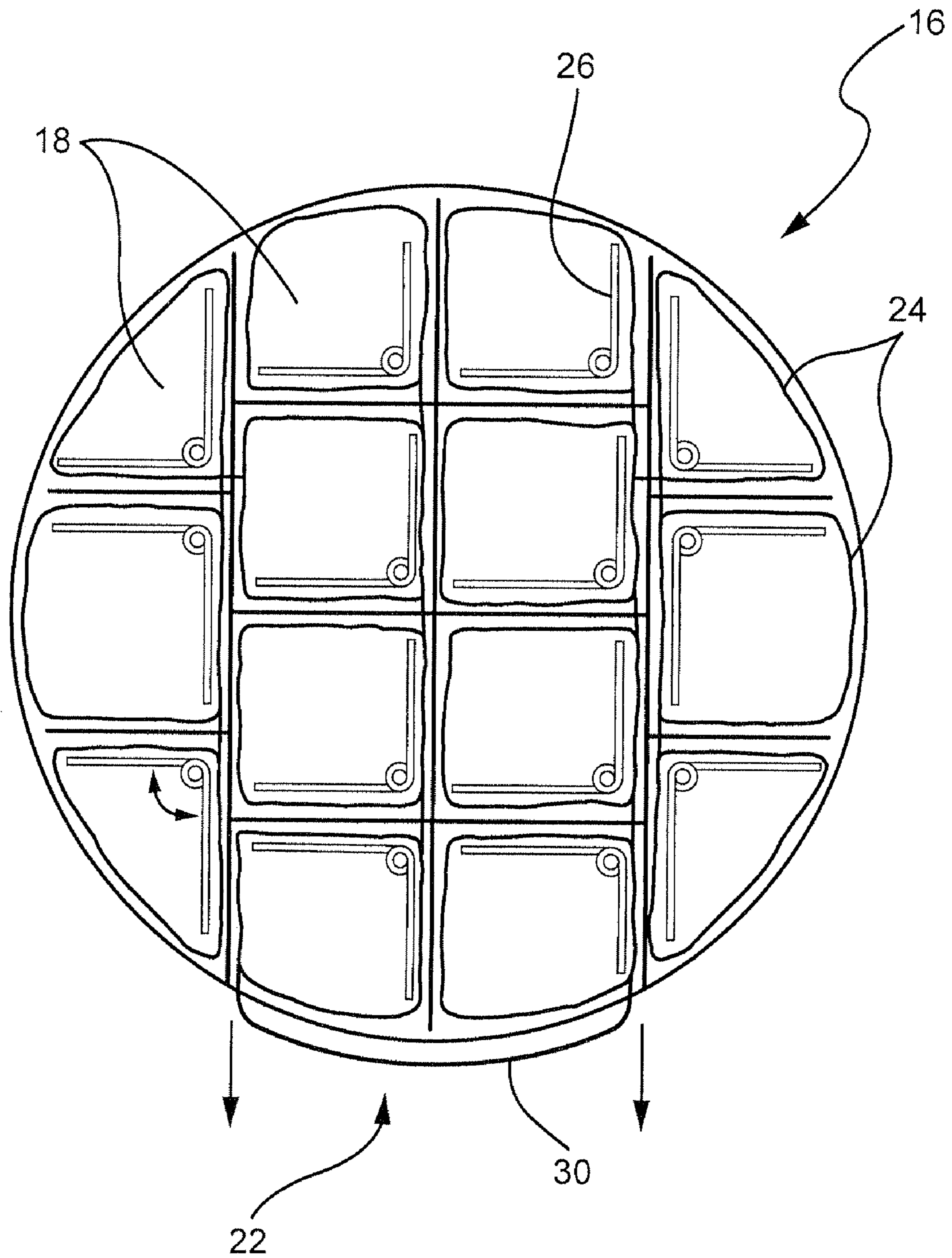

FIG. 3

STAND GOLF BAG WITH MECHANISM TO SECURE CLUBS

CROSS-REFERENCES TO RELATED APPLICATIONS

This application is a continuation of U.S. patent application Ser. No. 12/044,449, filed Mar. 7, 2008 now U.S. Pat. No. 7,775,353, which claims the benefit of U.S. Provisional Patent Application Ser. No. 60/893,406, filed Mar. 7, 2007, the entire contents of each of which are hereby incorporated by reference in this application.

STATEMENT REGARDING FEDERALLY SPONSORED RESEARCH OR DEVELOPMENT

(Not Applicable)

BACKGROUND OF THE INVENTION

Many golfers prefer walking while playing rather than riding in a golf cart. As such, stand bags have become popular, including a mechanism that extends stand legs when the bag is placed on the ground. See, for example, U.S. Pat. No. 5,857,567 and U.S. Pat. No. 4,834,235, the contents of which are hereby incorporated by reference. These bags typically also include a two-strap shoulder strap to facilitate carrying.

A problem arises, however, in that while walking, the clubs tend to bang into each other, which over time may cause damage to the club faces or grooves and at a minimum causes undesirable noise.

SUMMARY OF THE INVENTION

It would thus be desirable to provide a mechanism cooperable with the stand mechanism in a stand bag that secures the clubs in position when the bag is not on the ground and releases the clubs when the bag is set on the ground.

In an exemplary embodiment, a golf bag includes a main compartment with a plurality of sub-compartments, each sub-compartment being sized to receive at least one golf club, and a base unit affixed at a bottom of the main compartment and including a plurality of club end receptacles sized to receive a grip end of at least one golf club. A stand mechanism is cooperable with the main compartment and is configured to extend when the base unit is set on a surface and to retract when the base unit is lifted from the surface. A club lock mechanism is cooperable with the stand mechanism and includes an elastic member wound through each of the club end receptacles. The club lock mechanism is configured to expand the elastic member when the stand mechanism is extended and to contract the elastic member when the stand mechanism is retracted.

In another exemplary embodiment, a golf bag includes a stand mechanism that extends a stand when the bag is set on a surface and retracts the stand when the bag is lifted from the surface, and a club lock mechanism cooperable with the stand mechanism that secures golf clubs stored in the golf bag in position when the bag is not on the surface and releases the golf clubs when the bag is set on the surface.

BRIEF DESCRIPTION OF THE DRAWINGS

FIGS. 1 and 2 show a golf bag including an exemplary stand mechanism with supporting legs; and

FIG. 3 shows an exemplary base unit and club lock assembly.

DETAILED DESCRIPTION OF THE INVENTION

FIGS. 1 and 2 show a golf bag including an exemplary stand mechanism with a pair of supporting legs **14** in a retracted position in FIG. 1 and an extended position in FIG. 2. The bag **10** generally comprises a tubular main compartment **11** divided by dividers into a plurality of sub-compartments **12**, where each sub-compartment **12** is sized to receive at least one golf club. As shown in FIG. 1, a sub-compartment **12** is provided for each of the fourteen clubs typically carried by golfers.

A base unit **16** is affixed at a bottom of the main compartment **11**. With reference to FIG. 3, the base unit **16** includes a plurality of club end receptacles **18** disposed at a bottom end of each sub-compartment **12**. The club end receptacles **18** are sized to receive a grip end of at least one golf club.

A stand mechanism **20** is cooperable with the main compartment **11** and is configured to extend the stand legs **14** when the base unit **16** is set on a surface and to retract the stand legs **14** when the base unit is lifted from the surface. The stand mechanism **20** is biased toward the retracted position so that when the bag **10** is lifted off the ground, a biasing mechanism automatically pulls the stand legs **14** to their retracted position (shown in FIG. 1). Any suitable activating mechanism may be used as would be apparent to those of ordinary skill in the art. Many such mechanism are known, and further details thereof will not be described.

With reference to FIG. 3, the base unit **16** includes a club lock mechanism **22** cooperable with the stand mechanism **20**. In a preferred arrangement, the club lock mechanism **22** includes an elastic member **24** such as a strap or the like that is weaved in and around a plurality of leaf springs **26**, one each disposed in each of the club end receptacles **18**. The leaf springs **26** are biased open to thereby press the elastic member **24** against walls of the club end receptacles **18**. In this context, when the stand mechanism **20** is extended, an activating member **28** of the stand mechanism **20** is pushed against the base unit **16** as shown in FIG. 2 to thereby expand the elastic member **24** and set the club lock mechanism **22** in an open position. In this position, with the stand mechanism extended, golf clubs set in the club end receptacles **18** can be easily inserted and removed.

When the bag is picked up, a biasing component of the stand mechanism **20** retracts the stand legs **14** and extends the activating member **28** to thereby extend/stretch the elastic member **24** via leads **30**, which serves to contract the leaf springs **26** into gentle engagement with ends of the golf clubs. In this state as shown in FIG. 1, the clubs are secured in the club end receptacles **18** and are prevented from banging against each other while the user is walking with the bag.

Those of ordinary skill in the art will appreciate that alternative mechanisms may be used for securing and releasing the clubs in conjunction with extension and retraction of the stand legs, and the invention is not necessarily meant to be limited to the exemplary configuration illustrated in FIG. 3. For example, alternative configurations may include cylindrical openings or members that contract when the stand legs are retracted and that open when the stand legs are extended. Alternatively, an insert may be provided flush with a sidewall of the sub-compartments **12** or club end receptacles **18** when the stand legs are in the extended position, which insert may be deflected to contract the sub-compartments **12** for club end receptacles **18** when the stand legs are retracted.

3

Similar concepts may be applicable to a golf bag that does not include individual sub-compartments for each club as shown in FIG. 3. For example, the bag may include only three sub-compartments capable of receiving multiple clubs. In this instance, a larger mechanism for each compartment may be 5 activated/contracted or deactivated/extended in conjunction with the stand mechanism to secure and release the clubs when the bag is picked up or when the bag is set on the stand mechanism, respectively.

While the invention has been described in connection with 10 what is presently considered to be the most practical and preferred embodiments, it is to be understood that the invention is not to be limited to the disclosed embodiments, but on the contrary, is intended to cover various modifications and equivalent arrangements included within the spirit and scope 15 of the appended claims.

The invention claimed is:

1. A golf bag comprising:

a stand mechanism that extends a stand when the bag is set 20 on a surface and retracts the stand when the bag is lifted from the surface; and

a club lock mechanism cooperable with the stand mechanism, the club lock mechanism being brought into an engagement position in which the club lock mechanism 25 engages golf clubs stored in the golf bag to secure the golf clubs in position when the bag is not on the surface, and the club lock mechanism being brought into a

4

release position in which the club lock mechanism releases the golf clubs when the bag is set on the surface.

2. A golf bag comprising:

a stand mechanism displaceable between an extended position when the bag is set on a surface and a retracted 5 position when the bag is lifted from the surface; and

a club lock mechanism cooperable with the stand mechanism, the club lock mechanism including retaining members displaceable between an engagement position in which the retaining members are brought into a position engageable with golf clubs in the golf bag, and a 10 release position in which the retaining members are displaced from the position engageable with the golf clubs in the golf bag,

wherein the retaining members are displaced to the release position when the stand mechanism is in the extended position, and wherein the retaining members are displaced to the engagement position when the stand 15 mechanism is in the retracted position.

3. A golf bag according to claim 2, wherein the retaining members comprise leaf springs.

4. A golf bag according to claim 3, wherein the club lock mechanism further comprises an elastic member coupled 20 directly to the stand mechanism, the elastic member contracting the leaf springs into the position engageable with the golf clubs when the stand mechanism is in the retracted position.

* * * * *