



US008177807B2

(12) **United States Patent**  
**Bates et al.**

(10) **Patent No.:** **US 8,177,807 B2**  
(45) **Date of Patent:** **May 15, 2012**

(54) **EMBOLI FILTRATION SYSTEM AND METHODS OF USE**

(75) Inventors: **Mark C. Bates**, Charleston, WV (US);  
**Michael Hogendijk**, Palo Alto, CA (US);  
**Nicola A. Pisano**, Rancho Santa Fe, CA (US)

(73) Assignee: **Boston Scientific Scimed, Inc.**, Maple Grove, MN (US)

(\*) Notice: Subject to any disclaimer, the term of this patent is extended or adjusted under 35 U.S.C. 154(b) by 199 days.

(21) Appl. No.: **12/487,701**

(22) Filed: **Jun. 19, 2009**

(65) **Prior Publication Data**

US 2009/0259247 A1 Oct. 15, 2009

**Related U.S. Application Data**

(63) Continuation of application No. 11/037,881, filed on Jan. 18, 2005, now Pat. No. 7,563,272, which is a continuation of application No. 10/278,172, filed on Oct. 21, 2002, now abandoned, which is a continuation-in-part of application No. 09/774,197, filed on Jan. 29, 2001, now Pat. No. 6,468,291, which is a continuation-in-part of application No. 09/354,897, filed on Jul. 16, 1999, now Pat. No. 6,179,859.

(51) **Int. Cl.**  
**A61M 29/00** (2006.01)

(52) **U.S. Cl.** ..... **606/200; 606/191**

(58) **Field of Classification Search** ..... **606/200, 606/159, 114, 108, 113**

See application file for complete search history.

(56) **References Cited**

U.S. PATENT DOCUMENTS

3,592,186 A	7/1971	Oster
3,683,904 A	8/1972	Forster
3,996,938 A	12/1976	Clark, III
4,046,150 A	9/1977	Schwartz et al.
4,723,549 A	2/1988	Wholey et al.
4,790,812 A	12/1988	Hawkins, Jr. et al.
4,921,484 A	5/1990	Hillstead
4,969,891 A	11/1990	Gewertz
4,998,539 A	3/1991	Delsanti
5,002,560 A	3/1991	Machold et al.
5,011,488 A	4/1991	Ginsburg
5,071,407 A	12/1991	Termin et al.
5,102,415 A	4/1992	Guenther et al.
5,108,419 A	4/1992	Reger et al.
5,133,733 A	7/1992	Rasmussen et al.
5,329,942 A	7/1994	Gunther et al.
5,354,310 A	10/1994	Garnic et al.
5,370,657 A	12/1994	Irie

(Continued)

FOREIGN PATENT DOCUMENTS

EP 0533511 A1 3/1993

(Continued)

*Primary Examiner* — Tuan Nguyen

(74) *Attorney, Agent, or Firm* — Seager, Tufte & Wickhem LLC

(57) **ABSTRACT**

An emboli filtration apparatus is provided including a guide wire having a filter element captured thereon, so that the guide wire is free to rotate and translate while the filter element remains stationary. The apparatus allows for movement and rotation of the guide wire as devices are advanced over it to treat occlusive disease, substantially without dislodging the filter element. In a preferred embodiment, the guide wire includes a proximal stop configured to reposition the filter element during a medical procedure without having to remove or insert additional interventional devices.

**10 Claims, 7 Drawing Sheets**

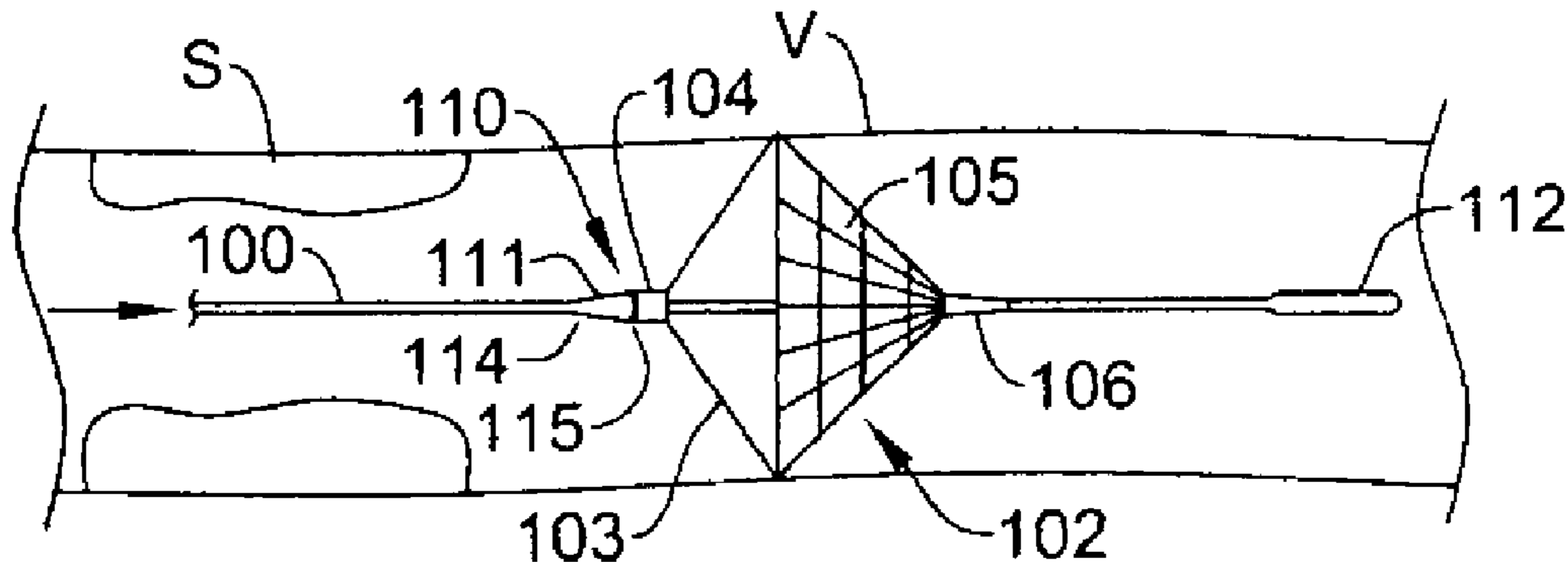

# US 8,177,807 B2

Page 2

## U.S. PATENT DOCUMENTS

5,415,630 A 5/1995 Gory et al.  
5,456,667 A 10/1995 Ham et al.  
5,476,104 A 12/1995 Sheahon  
5,658,296 A 8/1997 Bates et al.  
5,662,671 A 9/1997 Barbut et al.  
5,695,519 A 12/1997 Summers et al.  
5,769,816 A 6/1998 Barbut et al.  
5,779,716 A 7/1998 Cano et al.  
5,792,300 A 8/1998 Inderbitzen et al.  
5,795,322 A 8/1998 Boudewijn  
5,810,874 A 9/1998 Lefebvre  
5,814,064 A 9/1998 Daniel et al.  
5,817,102 A 10/1998 Johnson et al.  
5,827,324 A 10/1998 Cassell et al.  
5,833,650 A 11/1998 Imran  
5,846,260 A 12/1998 Maahs  
5,876,367 A 3/1999 Kaganov et al.  
5,893,867 A 4/1999 Bagaoisan et al.  
5,895,399 A 4/1999 Barbut et al.  
5,910,154 A 6/1999 Tsugita et al.  
5,954,745 A 9/1999 Gertler et al.  
5,976,172 A 11/1999 Homsma et al.  
6,059,814 A 5/2000 Ladd  
6,129,739 A 10/2000 Khosravi  
6,152,946 A 11/2000 Broome et al.  
6,171,327 B1 1/2001 Daniel et al.

6,179,859 B1 1/2001 Bates et al.  
6,179,861 B1 1/2001 Khosravi et al.  
6,245,012 B1 6/2001 Kleshinski  
6,277,138 B1 8/2001 Levinson et al.  
6,277,139 B1 8/2001 Levinson et al.  
6,325,815 B1 12/2001 Kusleika et al.  
6,336,934 B1 1/2002 Gilson et al.  
6,344,049 B1 2/2002 Levinson et al.  
6,346,116 B1 2/2002 Brooks et al.  
6,355,057 B1 3/2002 DeMarais et al.  
6,361,546 B1 3/2002 Khosravi  
6,371,971 B1 4/2002 Tsugita et al.  
6,432,122 B1 8/2002 Gilson et al.  
6,468,291 B2 10/2002 Bates et al.  
6,843,798 B2 1/2005 Kusleika et al.  
7,563,272 B2\* 7/2009 Bates et al. .... 606/200  
2002/0002384 A1 1/2002 Gilson et al.  
2002/0052626 A1 5/2002 Gilson et al.  
2003/0078614 A1\* 4/2003 Salahieh et al. .... 606/200

## FOREIGN PATENT DOCUMENTS

EP 0737450 A1 10/1996  
WO 9601591 A1 1/1996  
WO 9839053 A1 9/1998  
WO 9916382 A2 4/1999

\* cited by examiner

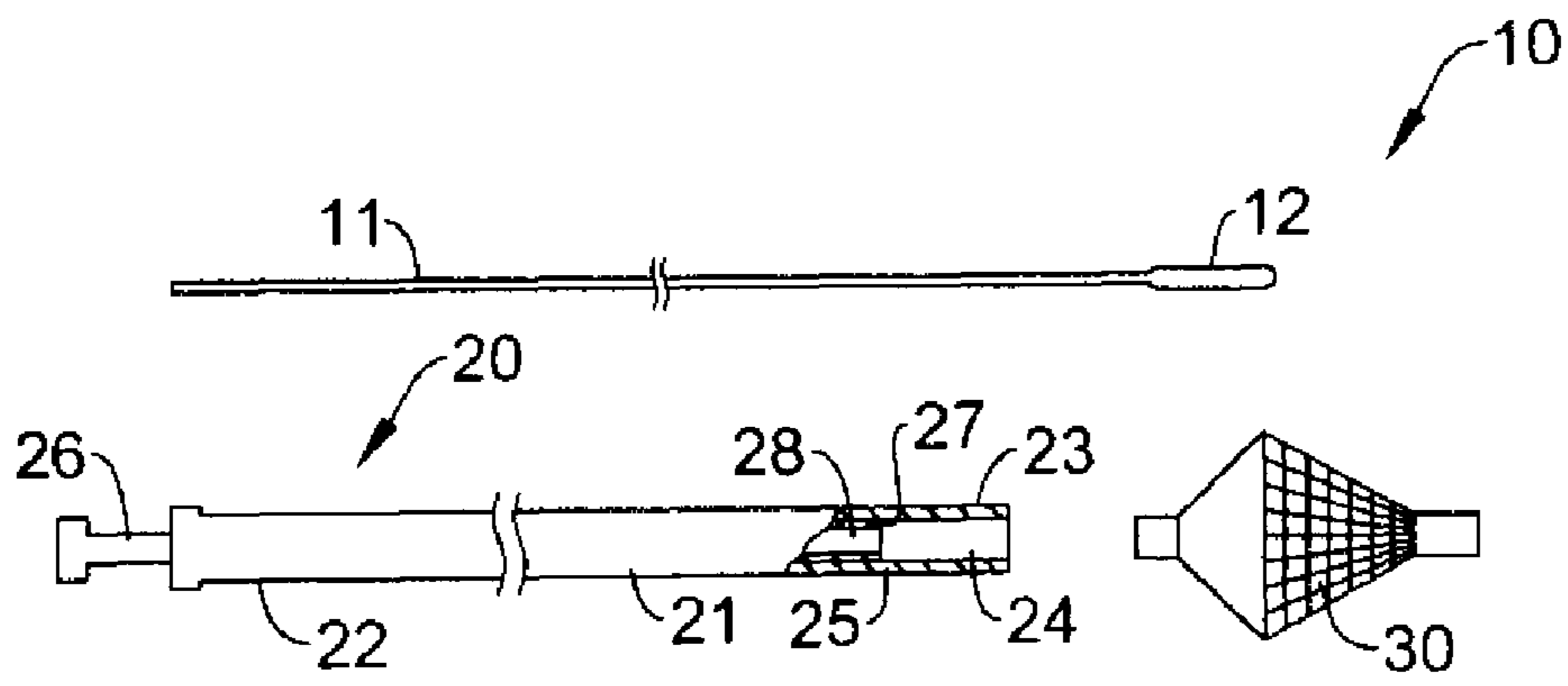

Figure 1

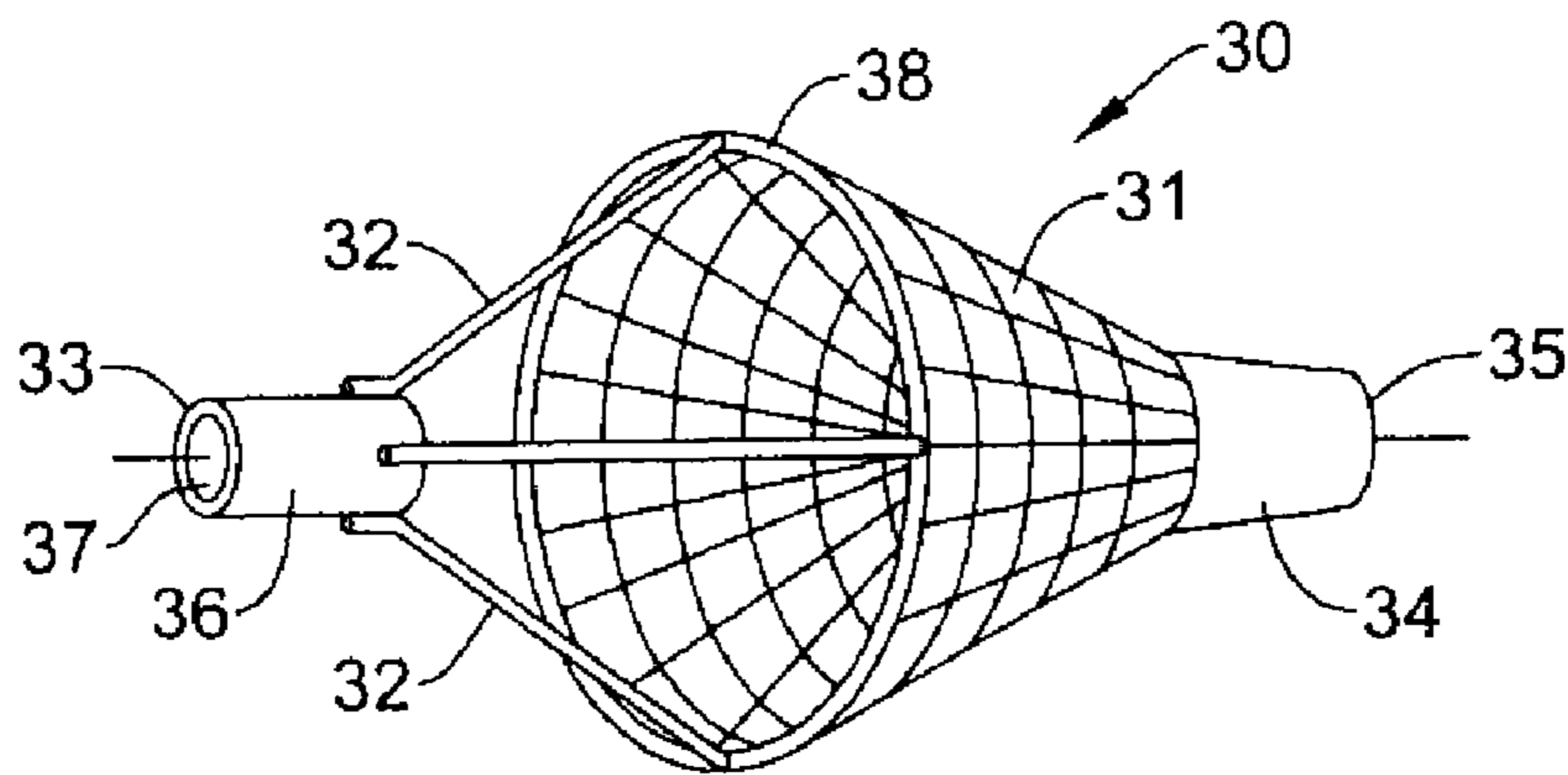

Figure 2A

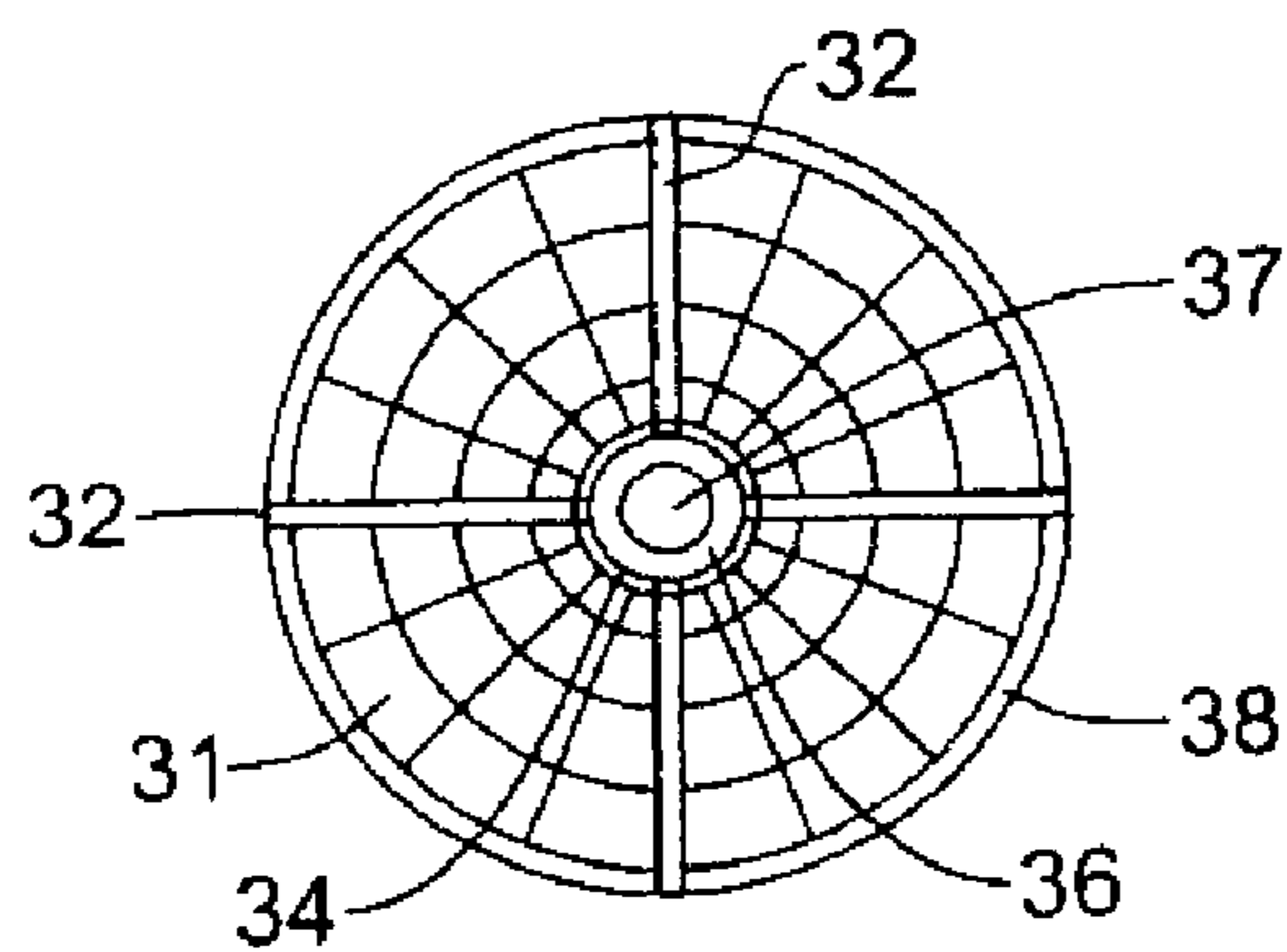

Figure 2B

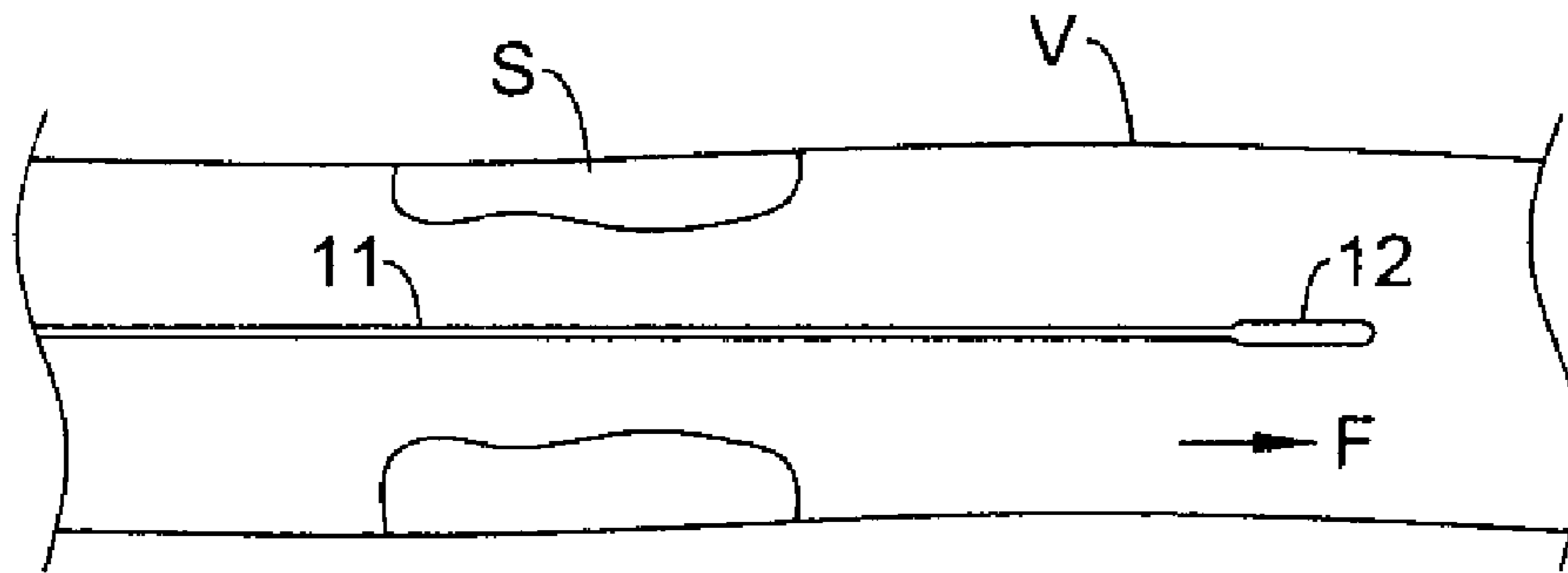

Figure 3A

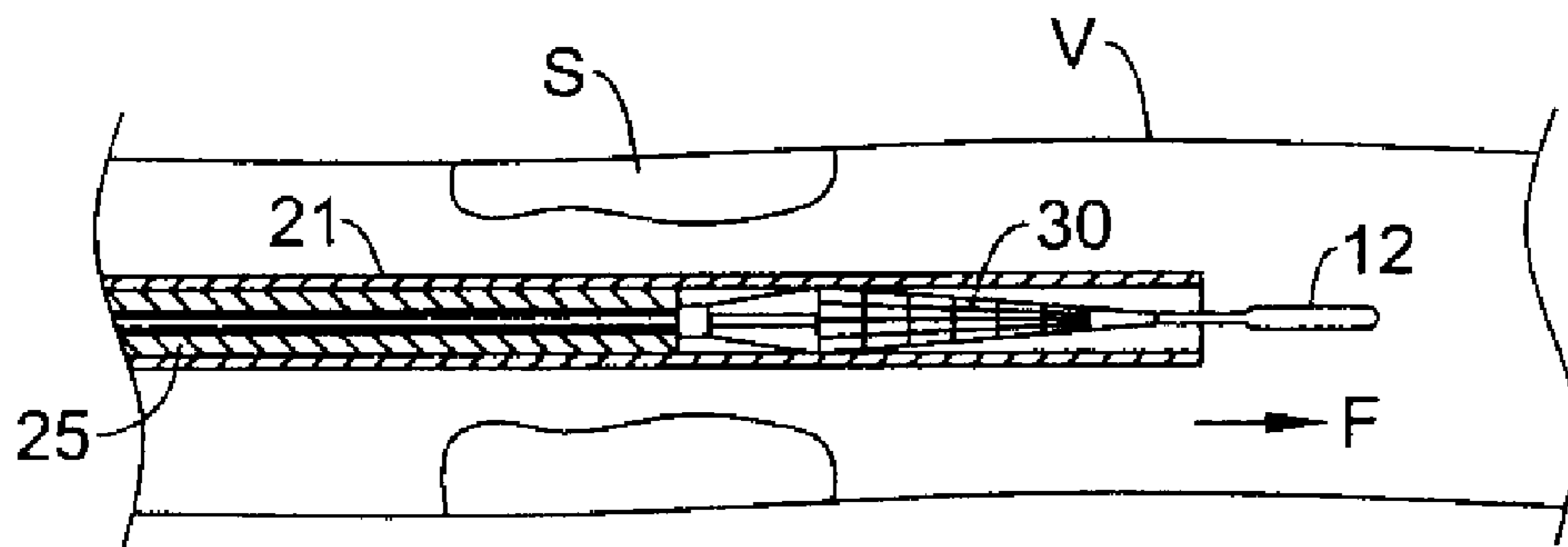

Figure 3B

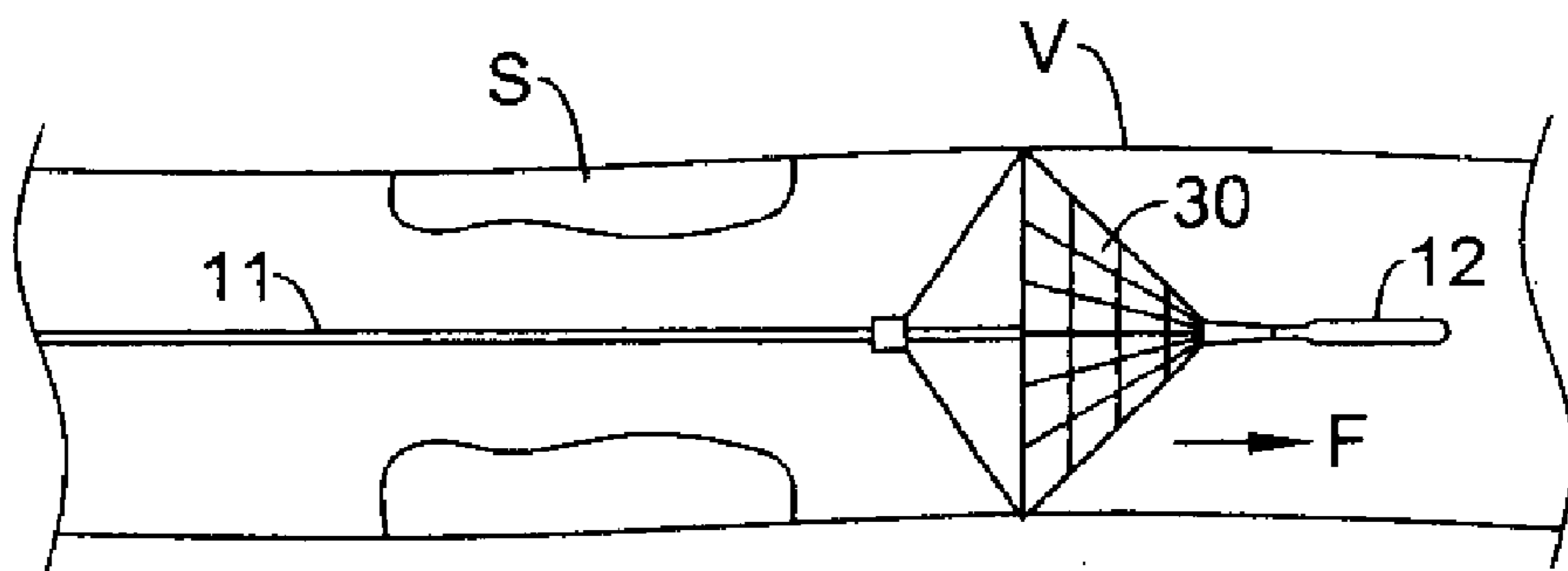

Figure 3C

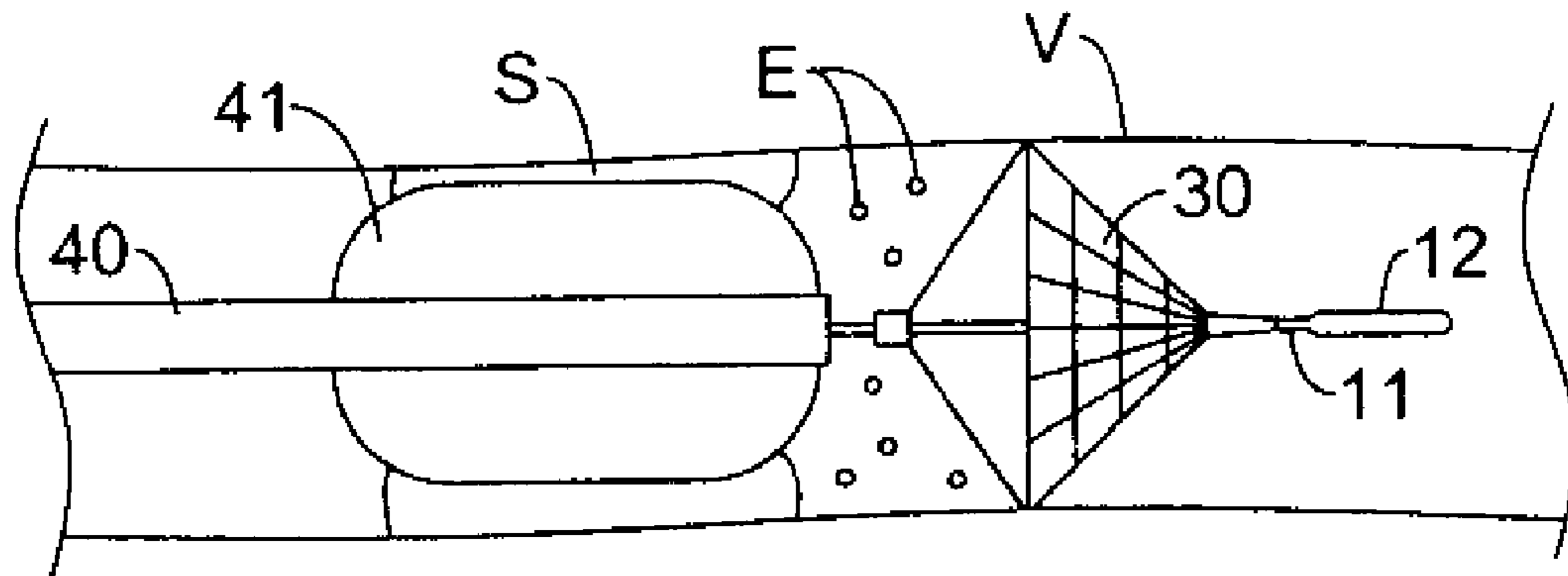

Figure 3D

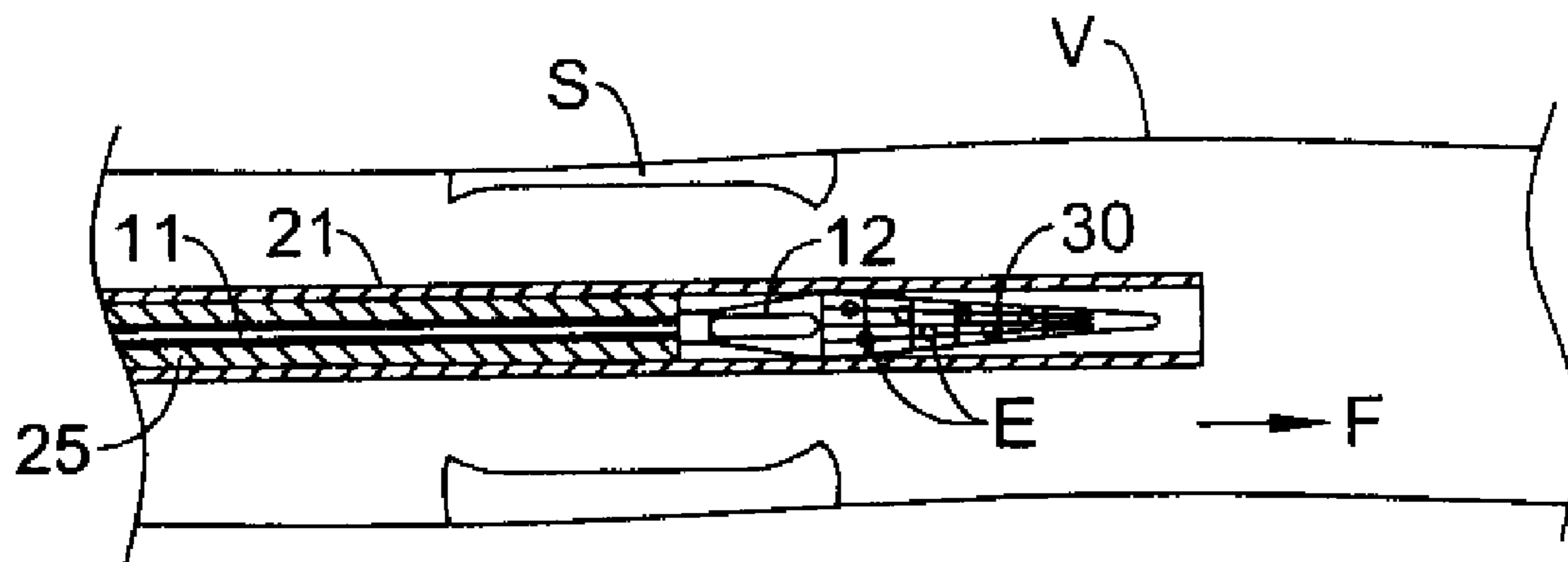

Figure 3E

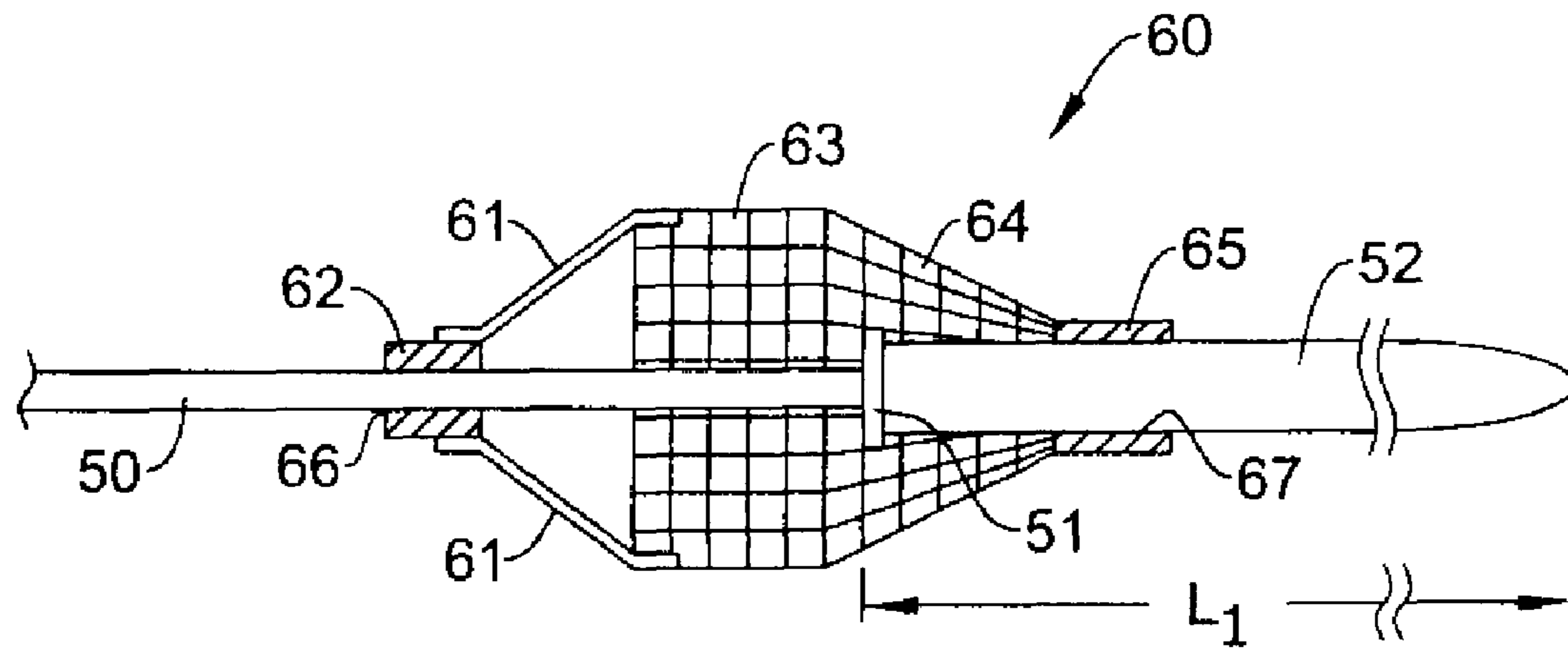

Figure 4A

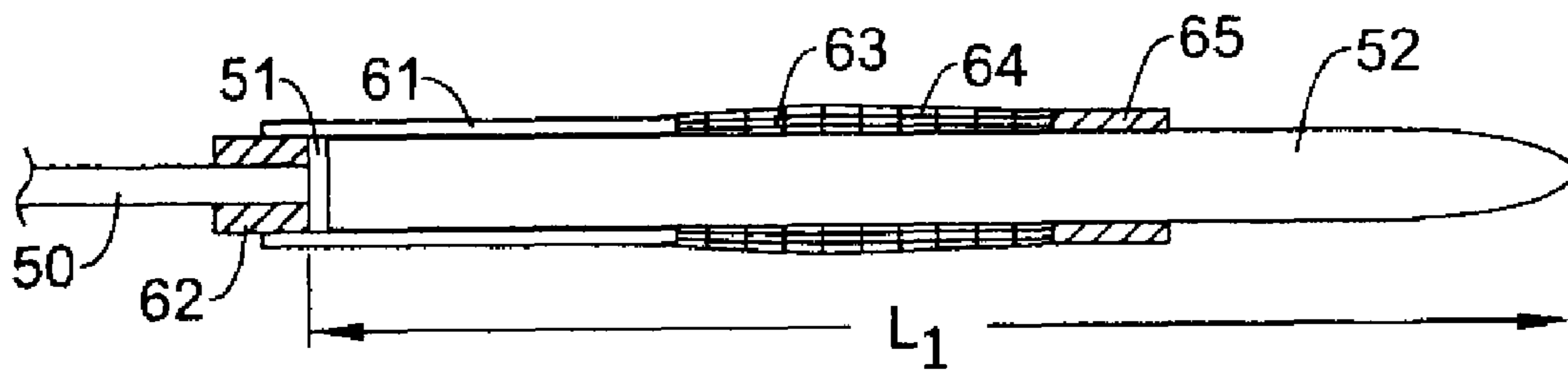
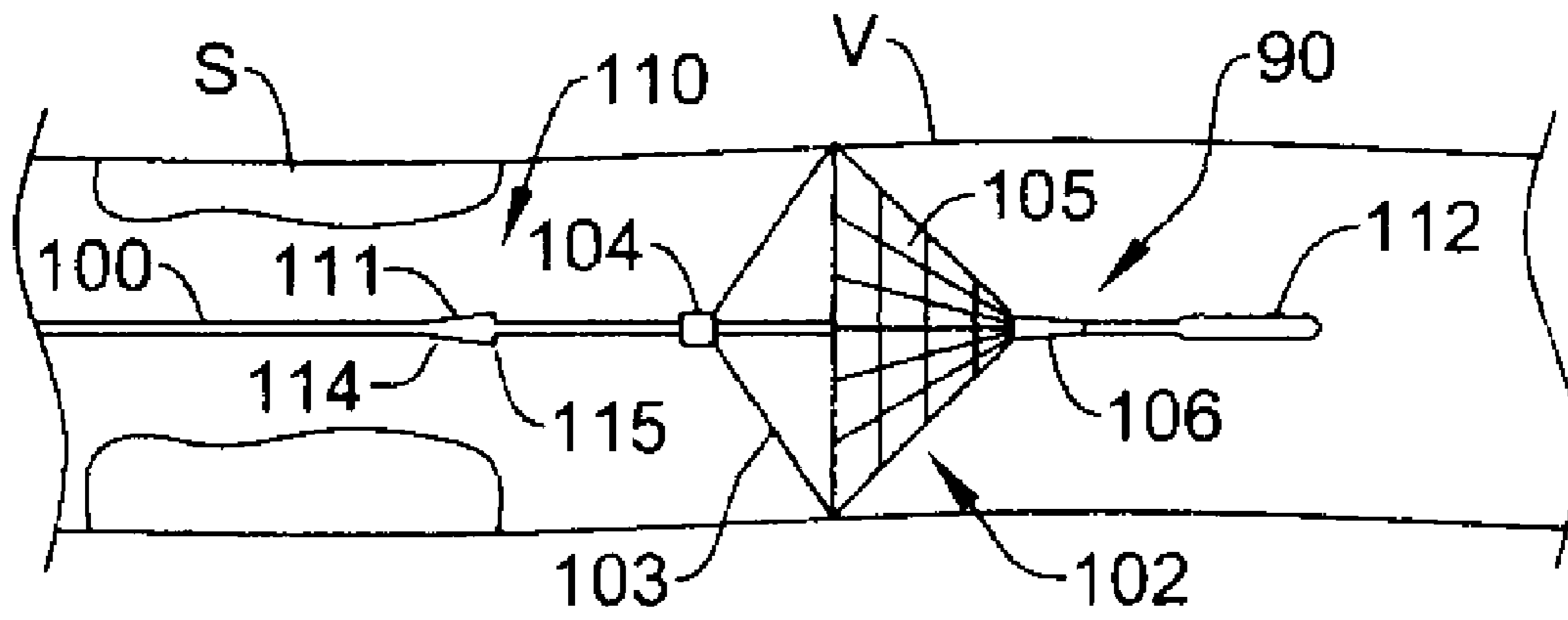
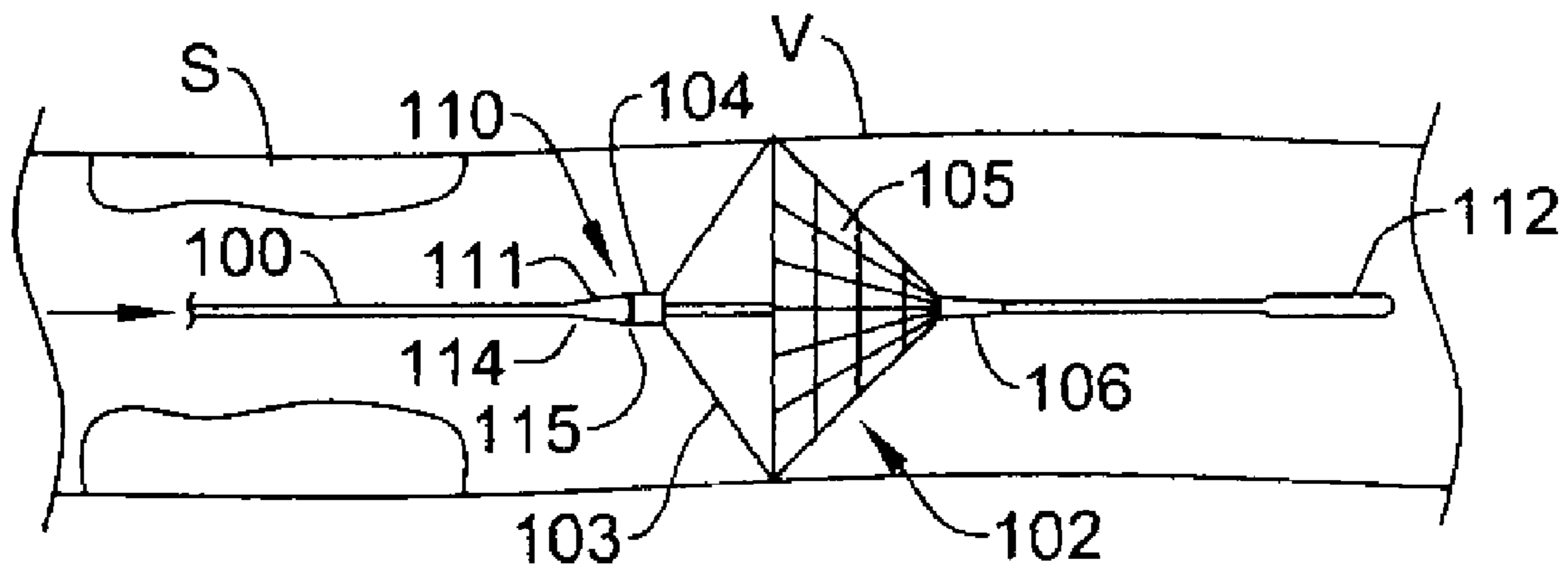

Figure 4B



*Figure 5A*



*Figure 5B*

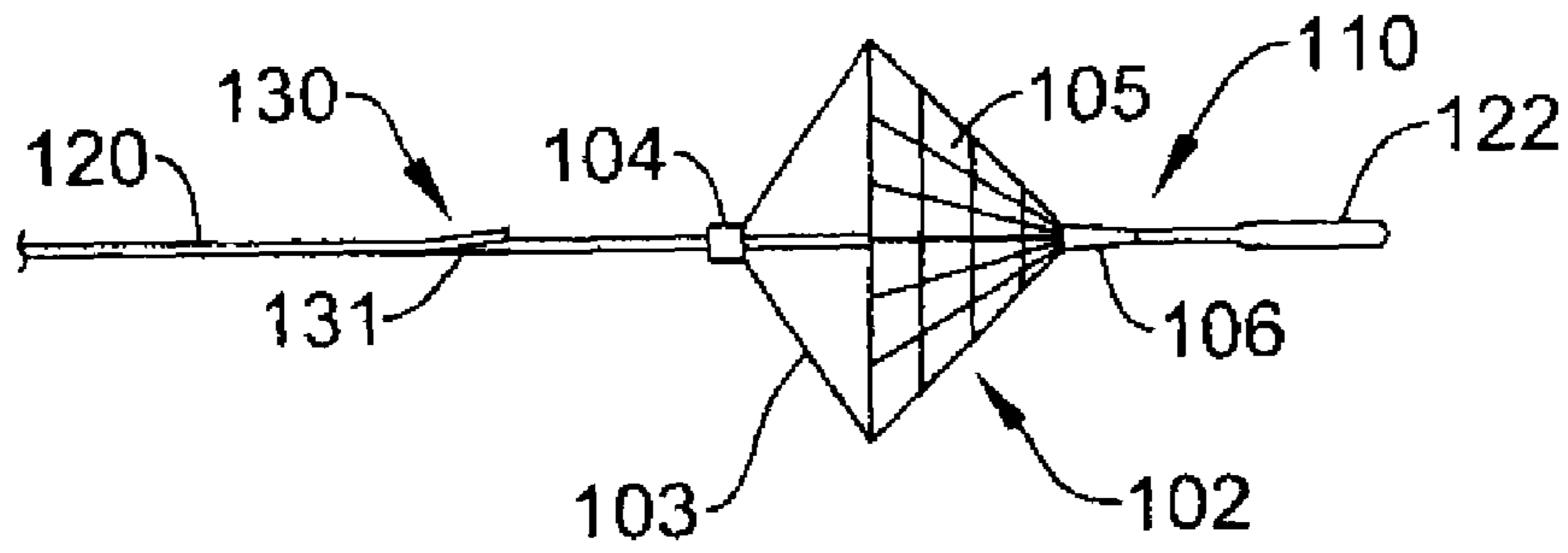

Figure 6A

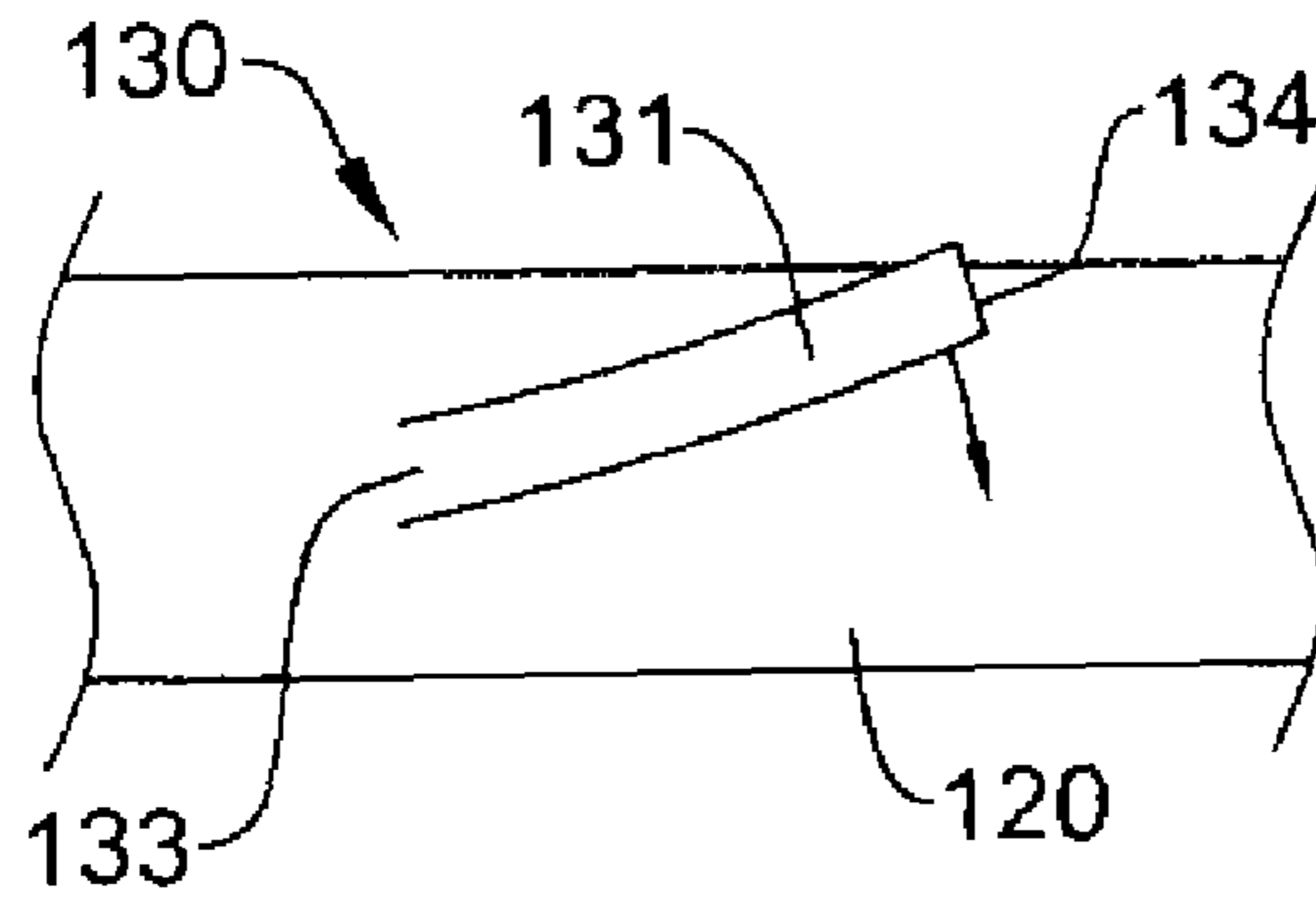

Figure 6B

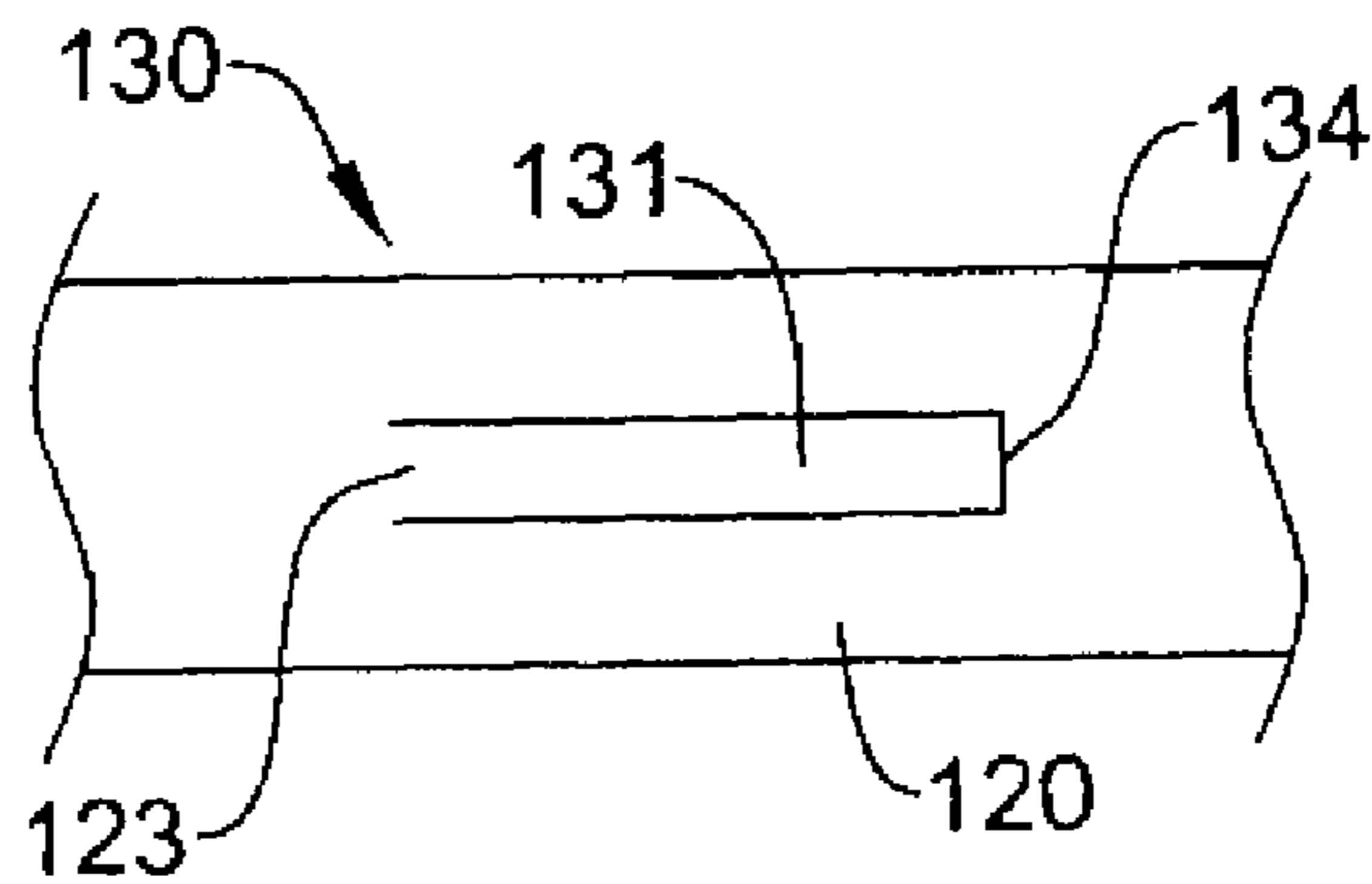
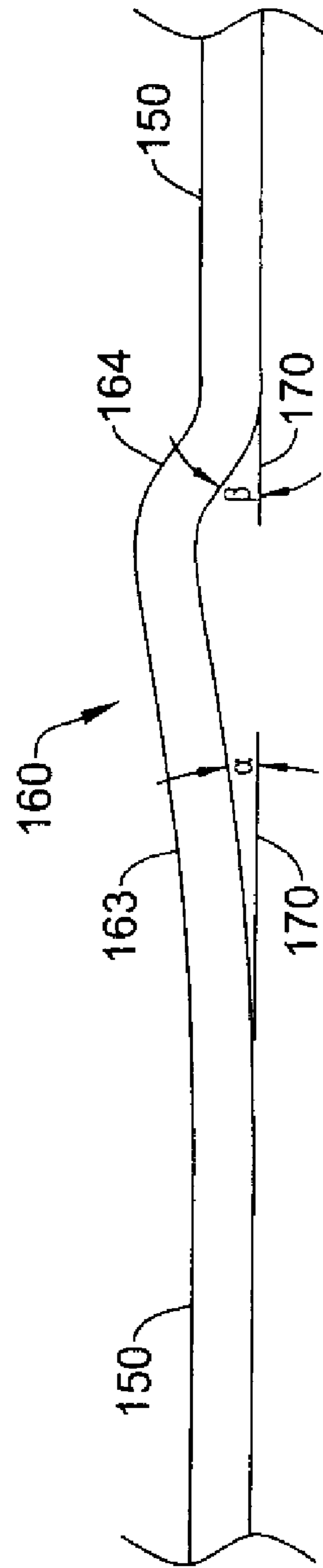
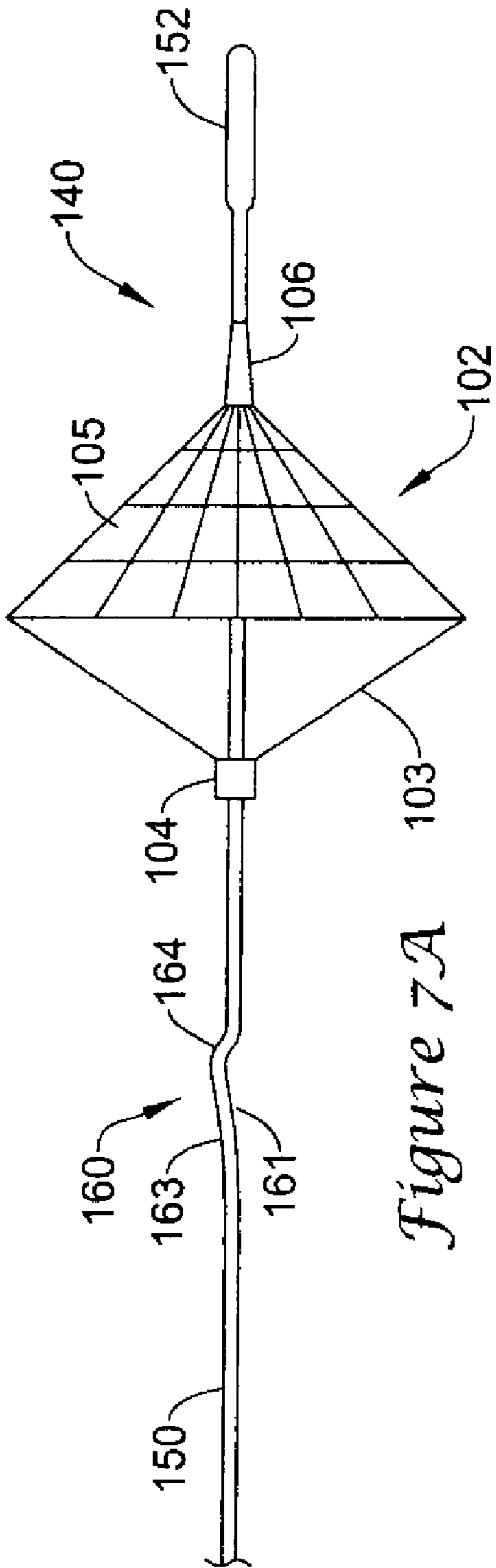

Figure 6C





## EMBOLI FILTRATION SYSTEM AND METHODS OF USE

### REFERENCE TO RELATED APPLICATIONS

The present application is a continuation of U.S. patent application Ser. No. 11/037,881, filed Jan. 18, 2005, now U.S. Pat. No. 7,563,272, which is a continuation of U.S. patent application Ser. No. 10/278,172, filed Oct. 21, 2002 now abandoned, which is a continuation-in-part of U.S. patent application Ser. No. 09/774,197, filed Jan. 29, 2001, now U.S. Pat. No. 6,468,291, which is a continuation-in-part of U.S. patent application Ser. No. 09/354,897, filed Jul. 16, 1999, now U.S. Pat. No. 6,179,859.

### FIELD OF THE INVENTION

The present invention relates to apparatus and methods for removing emboli from the blood stream that are generated during treatment of vascular disease, such as angioplasty, atherectomy or stenting. More particularly, an emboli filtration device and methods are provided having a captured filter that enables movement of a guide wire associated with the filter without displacing the filter.

### BACKGROUND OF THE INVENTION

Atherosclerosis and other vascular occlusive diseases are becoming prevalent today in many developed countries. In such diseases, the flow areas of blood vessels become narrowed or occluded by the buildup of plaque on the walls of the vessels, leading to ischemia, and depending upon the location of the vessel, damage to the organ or limb. A number of surgical and percutaneous procedures have been developed for treating stenosis in the coronary arteries and carotid arteries, including endarterectomy, angioplasty, atherectomy and stenting.

One problem frequently encountered during such procedures is that pieces of plaque ("emboli") often are dislodged from the stenosis or the vessel wall. Such emboli may travel into smaller diameter regions of the vasculature, blocking blood vessels and causing ischemic injury. This problem is especially severe where the emboli are permitted to travel into the coronary arteries and carotid arteries, and can result in infarction, stroke and even death.

Emboli filtration devices are known in which filter elements are deployed against the walls of a vessel distal of a stenosis. Such filters typically comprise a polymer or wire sac mounted on a distal region of a guide wire or angioplasty catheter, and permit blood to flow through the filter while trapping emboli. Once treatment of the stenosis is completed, the filter containing the captured emboli is contracted and withdrawn from the vessel.

For example, U.S. Pat. No. 5,814,064 to Daniel et al. (Daniel) describes an emboli capturing system having a radially expandable mesh filter disposed on the distal end of a guide wire. The filter is deployed distal of a region of stenosis, and any interventional devices, such as an angioplasty balloon or stent delivery system are advanced along the guide wire. The filter is designed to capture emboli generated during treatment of the stenosis while permitting blood to flow through the filter.

U.S. Pat. No. 4,723,549 to Wholey et al. (Wholey) describes an angioplasty catheter having a filter element disposed on its distal end. The filter is supported on a plurality of circumferential struts, and is expanded against an interior wall of a vessel, distal of a stenosis, by an inflation balloon.

An angioplasty balloon is disposed on the catheter proximal of the filter for dilating the stenosis. The filter captures emboli dislodged during the dilatation procedure, and then is contracted and removed from the vessel with the angioplasty catheter.

A key disadvantage of previously known emboli filtration systems, such as described in the foregoing patents, is that the filters in those devices are fixedly attached to the guide wire or angioplasty catheter, respectively. If the catheter or guide wire is rotated, bumped or moved after the filter has been deployed, there is a substantial risk that the filter will become temporarily dislodged or skewed, thereby permitting emboli to escape past the filter. Such motion is especially likely to occur when other devices such as an angioplasty balloon catheter are deployed along the guide wire after the filter is deployed, as in the Daniel patent.

U.S. Pat. No. 6,336,934 to Gilson et al. (Gilson) describes an embolic protection device having a collapsible filter element that is mounted on a tubular sleeve, wherein the tubular sleeve is slidable and rotatable on a guide wire between proximal and distal stops. The filter element on the tubular sleeve is delivered in a collapsed state within a catheter and self-deploys when the catheter is retracted. In the deployed state, the tubular sleeve facilitates some manipulation of the guide wire while potentially reducing disruption of the filter element.

One drawback associated with the device described in the Gilson patent is that the guide wire is delivered into the patient's vessel with the filter element disposed in a collapsed state between the proximal and distal stops near the distal end of the guide wire. The placement of the filter element near the distal end of the guide wire during delivery may make it difficult for the guide wire to negotiate tortuous anatomy during delivery. It would be advantageous to deliver the guide wire in an unencumbered manner to the site of the occlusion, then subsequently deliver other interventional devices including the filter element.

In view of these drawbacks of previously known devices, it would be desirable to provide emboli filtration apparatus and methods having a filter element that remains stationary once deployed.

It also would be desirable to provide emboli filtration apparatus and methods having a filter that may be deployed along a guide wire, but is configured so that subsequent displacements or rotation of the guide wire will not dislodge the filter.

It further would be desirable to provide emboli filtration apparatus and methods that reduce the risk of emboli escaping from a filter element.

It still further would be desirable to provide emboli filtration apparatus and methods that reduce the risk of trauma to vessel endothelium resulting from movement transferred to the emboli filtration apparatus.

It still further would be desirable to provide emboli filtration apparatus and methods that enable a filter element to be repositioned during a medical procedure without having to remove or insert additional interventional devices.

### SUMMARY OF THE INVENTION

In view of the foregoing, it is an object of the present invention to provide emboli filtration apparatus and methods having a filter element that remains stationary once deployed.

It is another object of the present invention to provide emboli filtration apparatus and methods having a filter that may be deployed along a guide wire, but is configured so that subsequent displacements or rotation of the guide wire will not dislodge the filter.

3

It is also an object of this invention to provide emboli filtration apparatus and methods that reduce the risk of emboli escaping from a filter element.

It is a further object of the present invention to provide emboli filtration apparatus and methods that reduce the risk of trauma to vessel endothelium resulting from movement transferred to the emboli filtration apparatus.

It is still a further object of the present invention to provide emboli filtration apparatus and methods that enable a filter element to be repositioned during a medical procedure without having to remove or insert additional interventional devices.

These and other objects of the present invention are accomplished by providing emboli filtration apparatus comprising a guide wire having a filter element captured thereon, so that the guide wire is free to rotate and translate while the filter element remains stationary. The apparatus thus allows for movement and rotation of the guide wire as devices are advanced over it to treat a stenosis, substantially without dislodging the filter element. Accordingly, the risk of permitting emboli to escape during temporary displacement or skewing of the filter element is reduced, as well as movement-induced trauma of the vessel endothelium.

In a preferred embodiment, the apparatus comprises a guide wire having a filter element captured for rotation and translation on a distal end thereof. The filter element preferably comprises a wire or polymer sac affixed to a plurality of self-expanding struts. The filter element has a contracted state, suitable for transluminal insertion disposed inside a retractable sheath, and a deployed state, wherein an outer perimeter of the filter element engages the walls of a vessel when the sheath is retracted proximally.

The filter element includes a proximal capture ring having a diameter that is larger than the diameter of the guide wire, but smaller than the diameter of the distal tip of the guide wire. The capture ring allows the guide wire to move freely relative to the filter element over a limited range, so that movement or rotation of the guide wire does not cause the filter to move or to scrape against the walls of the vessel. When it is desired to retract the filter element, the guide wire is pulled proximally so that the distal tip of the guide wire engages the capture ring and pulls the filter element back into a sheath to its contracted state.

Optionally, the filter element may include a cylindrical sleeve that ensures that the filter forms an adequate seal against the walls of the vessel in the deployed state, thus preventing bypass flow around the filter. The sleeve also assists in orienting the axis of the filter element parallel to the axis of the vessel.

In a further alternative embodiment of the present invention, the guide wire further comprises a proximal stop disposed proximal of the distal tip. The proximal stop is configured so that a filter element having an elastomeric capture ring may be advanced distally over the proximal stop during delivery of the filter element and locked distal of the proximal stop. As a further alternative, the proximal stop may be configured to permit the capture ring to pass distally over it, but prevent proximal passage.

During a medical procedure, the filter element is advanced to a central position between the proximal stop and distal tip. Advantageously, if it becomes necessary to advance the filter element distally during the medical procedure, the guide wire may be advanced distally to cause the proximal stop to abut the capture ring and urge the filter element distally. Using the proximal stop of the guide wire, it is not necessary to remove interventional devices or insert a push tube over the guide wire to reposition the filter element.

4

Methods of using the apparatus of the present invention to remove emboli during a surgical or percutaneous transluminal procedure also are provided.

#### BRIEF DESCRIPTION OF THE DRAWINGS

Further features of the invention, its nature and various advantages will be apparent from the accompanying drawings and the following detailed description of the preferred embodiments, in which:

FIG. 1 is a side view of the components of a first embodiment of apparatus constructed in accordance with the principles of the present invention;

FIGS. 2A-2B are, respectively, a perspective view and end view of the filter element of FIG. 1;

FIGS. 3A-3E are side sectional views showing deployment, use and removal of the apparatus of FIG. 1 in accordance with the methods of the present invention;

FIGS. 4A-4B are, respectively, side sectional views of an alternative embodiment of the apparatus of the present invention in deployed and contracted states;

FIGS. 5A-5B are side sectional views depicting use of an alternative embodiment of the present invention having a proximal stop disposed on a guide wire;

FIGS. 6A-6C are, respectively, a side view of an alternative embodiment of the proximal stop of FIGS. 5A-5B, and enlarged views of the proximal stop in relaxed and contracted states; and

FIGS. 7A-7B are side views of a further alternative embodiment of a proximal stop provided in accordance with principles of the present invention.

#### DETAILED DESCRIPTION OF THE INVENTION

The present invention is directed to an emboli filtration system and methods that filter out emboli generated during surgical or percutaneous interventional procedures. In accordance with the principles of the present invention, a filter element is captured on a guide wire so that the guide wire is capable of rotation and translation, without disturbing the placement of the filter element. Because the filter element is captured on the guide wire, however, the filter element is readily removed by retracting the guide wire into a sheath.

Referring to FIG. 1, apparatus 10 of a first embodiment of the present invention comprises guide wire 11, delivery sheath 20 and filter element 30. In accordance with the principles of the present invention, guide wire 11 includes enlarged diameter distal region 12. Guide wire 11 may be constructed of material commonly used in guide wire construction, such as stainless steel or a high strength polymer. Distal region 12, which acts as a distal stop to limit travel of filter element 30 in the distal direction, comprises a soft metal or metal alloy coil or may be formed from a flexible polymer, such as polyethylene or nylon, molded onto the distal region of the guide wire. Alternatively, guide wire 11 and distal region 12 may comprise a mechanism, such as are known in the art, for steering distal region 12 through a patient's vasculature. Illustratively, guide wire 11 may have a diameter of about 0.018 inches (0.46 mm) and the diameter of distal region 12 may be about 0.022 inches (0.56 mm).

Delivery sheath 20 comprises flexible catheter 21 having proximal end 22, distal end 23, and interior lumen 24. Push tube 25 is disposed within lumen 24, and includes proximal end 26, distal end 27 and guide wire lumen 28, to permit catheter 21 and push tube 25 to be advanced along guide wire 11. Proximal end 26 of push tube 25 extends through proximal end 22 of catheter 21, so that push tube 25 may be

translated in the distal and proximal directions relative to catheter **21**. Catheter **21** and push tube **25** preferably comprise flexible materials such as are commonly used in catheter construction, for example, polyethylene, polyurethane or nylon. Delivery sheath **20** preferably has an outer diameter of about 4 Fr.

Referring now to FIGS. **2A** and **2B**, filter element **30** comprises funnel-shaped filter sac **31** coupled to plurality of self-expanding struts **32** at proximal end **33** and soft elastomeric cone **34** at distal end **35**. Struts **32** are affixed to capture ring **36**, and self-expand from a contracted state, when filter element is disposed in lumen **24** of catheter **21**, and a deployed state, when filter element is ejected from delivery sheath **20**. In the deployed state, struts **32** extend outward to urge the perimeter of sac **31** into engagement with the walls of a vessel.

Struts **32** may comprise a resilient metal or metal alloy, such as stainless steel or nickel-titanium, or a resilient polymer. It is expected that at least three struts **32** spaced equidistant apart around the perimeter of sac **31** should be employed to provide adequate expansion and control of the sac, although a greater number may be used. Alternatively, struts **31** may comprise flexible strands, and expansion of sac **31** may be accomplished by adding a flexible and resilient self-expanding nickel-titanium hoop along perimeter **38** of the sac.

Particulate matter, such as emboli, pass through struts **32** and are trapped against sac **31**, which permits blood to pass freely through. The size of emboli trapped by sac **31** is determined by the pore size of the sac, and preferably is about 0.0012 inches (30 microns). Sac **31** may comprise a polymer sleeve affixed to struts **32** or a self-expanding wire mesh constructed from a resilient metal alloy, for example, nickel-titanium.

Capture ring **36** has bore **37** with an inner diameter greater than the diameter of guide wire **11**, but smaller than the diameter of distal region **12**. This allows guide wire **11** to be rotated or translated distally relative to filter element **30**, without imposing a force on the filter element that might temporarily dislodge the filter element. Accordingly, various devices, such as angioplasty catheters, atherectomy devices or stent delivery systems may be exchanged on guide wire **11** without disturbing filter element **30** or causing it to scrape against the walls of the vessel. As will of course be understood, capture ring **36** need not be a tubular member, but may have any suitable shape that allows guide wire **11** to pass freely through it.

Elastomeric cone **34** is coupled to the distal end of sac **31** and includes a tapered central lumen that permits guide wire **11** to freely pass through cone **34** with minimal clearance. Elastomeric cone **34** preferably comprises a non-stick or slick surface, such as polytetrafluoroethylene, and is designed so that emboli trapped in sac **31** are prevented from passing out of the filter element through the space between guide wire **11** and the lumen of elastomeric cone **34**. Cone **34** is sufficiently soft and flexible so that its lumen can expand to permit distal region **12** of guide wire **11** to be pulled proximally through the cone, and then the lumen will seal itself to prevent emboli from escaping through the lumen, as described hereinafter.

Referring now to FIG. **3**, preferred methods of using the apparatus of FIG. **1** are described. In FIG. **3A**, guide wire **11** first is percutaneously and transluminally inserted into vessel **V**, such as a coronary artery or common carotid artery, so that distal region **12** is disposed distal of stenosis **S** in the direction of blood flow (indicated by arrow **F**).

In FIG. **3B**, delivery sheath **20** with filter element **30** loaded in lumen **24** in the contracted state is advanced along guide

wire **11** until the filter element is disposed at a desired location distal of the stenosis, as determined, for example, by fluoroscopy. Proximal end **26** of push tube **25** is then held stationary while catheter **21** is retracted in the proximal direction.

As catheter **21** is retracted, struts **32** of filter element **30** expand outward to urge the perimeter of sac **31** into engagement with the walls of vessel **V**, as depicted in FIG. **3C**. Delivery sheath **20** then is withdrawn proximally and removed from guide wire **11**. Guide wire **11** then may be advanced a short distal distally, so that any incidental movement of the guide wire associated with exchanging interventional instruments along guide wire **11** will not cause distal region **12** to contact filter element **30**.

In FIG. **3D**, angioplasty catheter **40** is illustratively advanced along guide wire **11** until balloon **41** is disposed across the stenosis. Balloon **41** then is inflated and deflated for one or several cycles, as in conventional, to dilate and disrupt the plaque comprising stenosis **S** and increase the diameter of vessel **V**. During this dilatation procedure, particles of plaque or emboli **E** are generated. These emboli are carried by blood flow in direction **F** into sac **31** of filter element **30**, where they become trapped.

Insertion and advancement of angioplasty catheter **40** along guide wire **11** may cause the guide wire to be translated over a short range or rotated. Because filter element **30** is not affixed to guide wire **11** however, such motion of the guide wire is not transferred to the filter element. Instead, filter element **30** remains stationary even though the guide wire rotates or translates relative to the filter element.

Once balloon **41** has dilated stenosis **S**, angioplasty catheter **40** is withdrawn along guide wire **11** while leaving the guide wire in place. If desired, a stent delivery system (not shown) may be advanced along guide wire **11** and one or more stents deployed across the dilated stenosis to retain the patency of the dilated vessel.

When treatment of the stenosis is completed, delivery sheath **20** (with push tube **25** removed) may again be advanced along guide wire **11** to a position just proximal of filter element **30**. Guide wire **11** then is pulled proximally so that distal region **12** passes through elastomeric cone **34** and bears against capture ring **36**. The lumen in cone **34** seals itself after distal region **12** passes through it so that emboli trapped in sac **31** do not escape through the lumen of cone **34**.

When guide wire **11** is pulled further in the proximal direction, with catheter **21** held stationary, struts **32** are forced radially inward by the distal edge of the catheter. This in turn causes sac **31** to disengage the vessel walls. As the guide wire continues to be pulled proximally, struts **32** cause sac **31** to collapse inward to its contracted position and the filter element is retracted into lumen **24** of catheter **21**. Emboli **E** are trapped and retained in filter element **30** throughout treatment of the stenosis, and are withdrawn from the vessel when the filter element is retracted within catheter **21**. Catheter **21** then is removed from the vessel.

Referring now to FIGS. **4A** and **4B**, an alternative embodiment of the filter element and guide wire of the present invention is described. Guide wire **50** is similar in construction to guide wire **11** described with respect to FIG. **1**, except that it includes flange **51** on enlarged diameter distal region **52** of guide wire **50**, and enlarged distal region **52** has length  $L_{sub.1}$  that is longer than the length of the filter element **60** in the contracted state.

Distal region **52** may be formed from a malleable material, a coil spring, or a pliable thermoplastic material molded onto guide wire **50**, and preferably is covered with a smooth hydrophilic coating to facilitate movement of filter element **60** as described hereinafter. Alternatively, guide wire **50** and distal

region 52 may comprise a mechanism, such as are known in the art, for steering distal region 52 through a patient's vasculature. Distal region 52 also may comprise a radiopaque material or may include a radiopaque band (not shown) to assist in visualization and placement of the guide wire.

Filter element 60 comprises self-expanding struts 61 coupled to capture ring 62 and tubular sleeve 63. Sleeve 63 is affixed at its distal end to funnel-shaped filter sac 64, which in turn is coupled to distal ring 65. Capture ring 62 has bore 66 with an inner diameter larger than the diameter of guide wire 50, but smaller than the diameter of distal region 52. Accordingly, guide wire 50 may freely translate and rotate through bore 66 of capture ring 62 while the filter element remains stationary.

Distal ring 65 has bore 67 with a diameter slightly larger than the diameter of distal region 52. This enables distal ring 65 to slide or rotate freely over distal region 52, but with minimal clearance for emboli to escape from sac 64 through the annulus between distal ring 65 and distal region 52. Distal region 52 includes flange 51, which has a diameter that is larger than the diameter of bore 66 of capture ring 62. Thus, filter element 60 is captured on guide wire 50 proximally by distal ring 65 abutting against flange 51, and distally by capture ring 62 abutting against flange 51.

Sleeve 63 and sac 64 filter blood passing through the vessel, and preferably have a pore size selected to filter out particles having a diameter greater than 0.0012 inches (30 microns). Sleeve 63 and sac 64 preferably comprise a flexible woven metal alloy, polymer tube, or perforated fabric, and are expanded to the deployed state, as shown in FIG. 4A, by struts 61. Advantageously, sleeve 63 is designed so that its perimeter conforms to the inner diameter of the vessel to seal against bypass flow, even in curved vessels. In addition, sleeve 63 tends to prevent skewing of the filter element and ensures that the filter is properly oriented parallel to the axis of the vessel when the filter element is deployed.

Filter element 60 is suitable for delivery percutaneously and transluminally to a desired location in a vessel using delivery sheath 20 of FIG. 1. In particular, struts 61 may be radially compressed to collapse sleeve 63 and sac 64, as shown in FIG. 4B, thereby permitting the filter element to be loaded into lumen 24 of catheter 21 so that capture ring 62 abuts against distal end 27 of push tube 25.

Deployment of filter element 60 is similar to the method described with respect to FIGS. 3B and 3C. Specifically, delivery sheath 20 is advanced through a vessel with distal region 52 extending beyond distal end 23 of catheter 21. Once distal region 52 has crossed the stenosis, as confirmed by fluoroscopy, push tube 25 is held place and catheter 2 is retracted proximally. Alternatively, push tube 25 may be omitted and guide wire 50 may be held stationary with filter element 60 held in position by flange 51. Retraction of catheter 21 uncovers filter element 60, allowing struts 61 to expand outward and urge the perimeter of sleeve 63 and sac 64 into engagement with the walls of the vessel.

Delivery sheath 20 then is removed, and one or more interventional devices may be serially employed on guide wire 50. Like the embodiment of FIG. 1, motion imparted to guide wire 50 during exchange of instruments along the guide wire causes the guide wire to slide through filter element 60 without causing skewing or displacement of the filter element. Advantageously, this prevents emboli from escaping sac 64 or damage to the endothelium caused by scraping of the filter element.

Once treatment of the stenosis is completed, the treatment device (e.g., angioplasty catheter, etc.) is removed, and delivery sheath 20 is again advanced along guide wire 50. When

distal end 23 of catheter 21 is disposed adjacent to capture ring 62, guide wire 50 is pulled proximally. As a result of this motion, distal region 52 passes through filter element 60 until flange 51 abuts against capture ring 62. Further proximal movement of guide wire 50 causes struts 61 to be urged inward, collapsing sleeve 63 and sac 64 so that they can be drawn into lumen 24 of catheter 21.

Unlike the embodiment of FIG. 1, where the distal region passes through cone 34, length L.sub.1 is sufficiently long so that distal ring 65 is still disposed over the enlarged diameter of distal region 52 when the filter element is in the contracted state. Accordingly, when filter element 60 is contracted for removal, emboli cannot escape through bore 67 of distal ring 65, since the bore continues to be substantially blocked by distal region 52 of guide wire 50. Delivery sheath 20, guide wire 50 and filter element 60 then are removed from the vessel with any emboli trapped within the contracted filter element.

In a preferred embodiment of the apparatus of FIG. 4, guide wire 50 has a suitable length for transluminal percutaneous applications and a diameter in a range of about 0.006 to 0.025 inches, and more preferably 0.012 inches. Distal region 52 of guide wire 50 has a diameter larger than the diameter of guide wire 50, and preferably in a range of about 0.010 to 0.038 inches, more preferably 0.018 inches.

While filter element 60 may comprise any length suitable for an intended application, in one preferred embodiment, filter element 60 has a deployed length of 3.5 cm and a maximum deployed diameter of 12 mm. For this embodiment, length L.sub.1 of distal region 52 preferably is 5.0 cm. For a guide wire having a diameter of 0.012 inches and distal region having a diameter of 0.018 inches, capture ring 62 preferably has an inner diameter of 0.014 inches and an outer diameter of 0.018 inches. In this case distal ring 65 preferably has an inner diameter of 0.0181 inches and an outer diameter of 0.024 inches.

Referring now to FIG. 5, apparatus 90 of an alternative embodiment of the present invention comprises guide wire 100 and filter element 102. Filter element 102 preferably is constructed in accordance with filter element 30 of FIGS. 1-3. Specifically, filter element 102 comprises funnel-shaped filter sac 105 coupled to plurality of self-expanding struts 103 at a proximal end and elastomeric cone 106 at a distal end. Struts 103 are affixed to capture ring 104, as described in detail hereinabove with respect to FIG. 2. Optionally, filter element 102 also may comprise cylindrical sleeve 63, as described hereinabove with respect to FIG. 4, disposed between struts 103 and sac 105.

Guide wire 100 comprises proximal stop 110 and distal region 112. Distal region 112 serves as a distal stop that limits the distal movement of filter element 102 along guide wire 100, as described hereinabove. Proximal stop 110 has proximal and distal ends 114 and 115 and taper 111 disposed therebetween, as shown in FIG. 5A. Taper 111 of guide wire 110 spans from proximal end 114, which preferably has a guide wire diameter of about 0.018 inches, to distal end 115, which preferably has an enlarged diameter of about 0.022 inches. Proximal stop 110 and distal region 112 are spaced apart such a distance that filter element 102, when deployed therebetween, will not be disturbed by incidental longitudinal movements of guide wire 100.

Apparatus 90 of FIG. 5 preferably is deployed in the manner described hereinabove with respect to apparatus 10 of FIGS. 1-3, except as noted below. In a first step, guide wire 100 is percutaneously and transluminally inserted into treatment vessel V under fluoroscopy, with proximal stop 110 preferably being disposed just distal of stenosis S. In a next step, filter element 102 is advanced along guide wire 100 in a

contracted state, preferably being contracted within lumen 24 of catheter 21, as described hereinabove with respect to FIG. 3B. Push tube 25 of FIG. 3B then is advanced distally so that a distal end of push tube 25 abuts capture ring 104 and advances filter element 102 distally over guide wire 100.

As push tube 25 advances filter element 102, elastomeric cone 106 is pushed distally over proximal stop 110 of guide wire 100. Elastomeric cone 106 is configured to be flexible enough to radially expand over the enlarged diameter of distal end 115 of proximal stop 110. After being advanced over distal end 115, elastomeric cone 106 then substantially seals itself about guide wire 100 to prevent emboli from subsequently escaping when a medical procedure is performed.

As push tube 25 further is advanced, capture ring 104 then is advanced over proximal stop 110. Capture ring 104 also is compliant enough to expand over the enlarged diameter of distal end 115 when advanced distally, and then substantially seals itself about guide wire 100 after it passes over proximal stop 110. Once filter element 102 is disposed between proximal stop 110 and distal region 112, filter element 102 is deployed, e.g., by proximally retracting catheter 21 while holding push tube 25 stationary. The catheter and push tube then may be removed from the patient's vessel.

Once deployed, filter element 102 preferably is provided in a central position between proximal stop 110 and distal region 112, as depicted in FIG. 5A, either by proximally retracting or distally advancing guide wire 100 under fluoroscopy. In this central position, incidental movements of guide wire 100 will not substantially disturb filter element 102.

If it becomes necessary to advance filter element 102 distally during the medical procedure, guide wire 100 may be advanced distally by a physician until distal end 115 of proximal stop 110 abuts capture ring 104 and gently urges filter element 102 distally, as shown in FIG. 5B. Advantageously, this enables filter element 102 to be advanced distally without having to remove angioplasty or stenting apparatus, then having to advance a push tube over then length of guide wire 100. Upon repositioning of filter element 102, guide wire 100 preferably is repositioned to the central position depicted in FIG. 5A, so that incidental movements of guide wire 100 do not disturb filter element 102.

When treatment of the stenosis is completed and any emboli are captured within sac 105 of filter element 102, delivery sheath 20 (with push tube 25 removed) may be advanced to a location just proximal of filter element 102. Guide wire 100 then is retracted proximally so that distal region 112 passes through elastomeric cone 106 and bears against capture ring 104, as described hereinabove with respect to FIG. 3E. A lumen of cone 106 seals itself after distal region 112 passes through to prevent emboli from escaping downstream. Distal region 112 then abuts capture ring 104 and pulls filter element 102 in a proximal direction. With the catheter held stationary, struts 103 are forced radially inward by the distal edge of the catheter to cause filter element 102 and any emboli captured therein to be removed via the catheter.

Advantageously, the one-way stop feature of proximal stop 110 allows guide wire 100 to be advanced through a patient's vasculature without having filter element 102 disposed on the guide wire. This facilitates advancement of guide wire 100 through a patient's tortuous vasculature. Then, when guide wire 100 is properly positioned in a vessel unencumbered, filter element 102 may be advanced distally over proximal stop 110, and securely positioned between proximal stop 110 and distal region 112 during the medical procedure.

Referring now to FIG. 6, an alternative embodiment of proximal stop 110 of the embodiment of FIG. 5 is described.

In FIG. 6A, guide wire 120 preferably is provided substantially in accordance with guide wire 11 of FIG. 1, and comprises enlarged diameter distal region 122, which acts as a distal stop to limit travel of filter element 102 in the distal direction, as described hereinabove. Guide wire 120 further comprises proximal stop 130, which includes at least one depressible tab 131 having proximal end 133 and distal end 134, as shown in FIGS. 6B-6C.

Proximal end 133 of depressible tab 131 is affixed to guide wire 120, e.g., using a solder, while distal end 134 is biased to extend slightly radially outward from guide wire 120 in a relaxed state, as shown in FIG. 6B. Depressible tab 131 may comprise a slight concave curvature to cause distal end 134 to be biased radially outward or, alternatively, proximal end 133 may be affixed to guide wire 120 in such a manner that allows distal end 134 to be biased radially outward in the relaxed state.

Depressible tab 131 is flexible so that it may be transformed between the relaxed state, shown in FIG. 6B, and a contracted state, as shown in FIG. 6C. In the contracted state, external compressive forces cause depressible tab 131 to be substantially flush with an exterior surface of guide wire 120. Guide wire 120 optionally may comprise a shallow slot (not shown) disposed in a lateral surface that is adapted to receive depressible tab 131 in the contracted state. When depressible tab 131 is contracted, as shown in FIG. 6C, the shallow slot serves to ensure that depressible tab 131 does not extend radially beyond guide wire 120.

Apparatus 110 of FIG. 6 preferably is deployed in the manner described hereinabove with respect to apparatus 10 of FIGS. 1-3, except as noted below. In a first step, guide wire 120 is percutaneously and transluminally inserted until proximal stop 130 is disposed just distal of a stenosis. In a next step, filter element 102 is advanced along guide wire 120 in a contracted state, preferably being contracted within lumen 24 of catheter 21, as described hereinabove with respect to FIG. 3B. Push tube 25 of FIG. 3B then is advanced distally so that a distal end of push tube 25 abuts capture ring 104 and advances filter element 102 distally.

As push tube 25 advances filter element 102, elastomeric cone 106 is pushed distally over proximal stop 130. Depressible tab 131 assumes the contracted state, depicted in FIG. 6C, as filter element 102 is advanced distally to facilitate advancement of elastomeric cone 106 over proximal stop 130. Elastomeric cone 106 also may radially expand over proximal stop 130, if necessary, and then substantially seal itself about guide wire 120 after it passes over proximal stop 130. As push tube 25 further is advanced, capture ring 104 then is advanced over proximal stop 130 in the same manner as elastomeric cone 106.

After elastomeric cone 106 and capture ring 104 are advanced distally over proximal stop 130, depressible tab 131 returns to the relaxed state, depicted in FIG. 6B. Filter element 102 then is deployed between proximal stop 130 and distal region 122, e.g., by proximally retracting catheter 21 while holding push tube 25 stationary. The catheter and push tube then may be removed from the patient's vessel.

Once deployed, filter element 102 preferably is provided in a central position between proximal stop 130 and distal region 122 by proximally retracting or distally advancing guide wire 120 under fluoroscopy. If it becomes necessary to advance filter element 102 distally during a medical procedure, guide wire 120 may be advanced distally to cause distal end 134 of depressible tab 131 to abut capture ring 104 and gently urge filter element 102 distally. Upon completion of the medical procedure, catheter 21 may be advanced distally over guide wire 120 to cause filter element 102 and any emboli captured

## 11

therein to be removed via the catheter, as described in detail hereinabove with respect to FIG. 3E.

Referring now to FIG. 7, a further alternative embodiment of the present invention is described, whereby guide wire **11** of FIG. 1 is slightly bent to comprise a one-way proximal stop mechanism. Guide wire **150** of FIG. 7A comprises enlarged diameter distal region **152**, which acts as a distal stop to limit travel of filter element **102** in the distal direction. Guide wire **150** further comprises proximal stop **160**, which includes bent section **161** of guide wire **150** having proximal taper **163** and distal taper **164**. Proximal taper **163** comprises angle .alpha. with respect to longitudinal axis **170** of guide wire **150**, while distal taper **164** comprises angle .beta. with respect to longitudinal axis **170**, as depicted in FIG. 7B.

Proximal stop **160** is configured to facilitate distal advancement of filter element **102** over bent section **161** of guide wire **150** via proximal taper **163**, while inhibiting movement of filter element **102** in a proximal direction over bent section **161** via distal taper **164**. In a preferred embodiment, angle .beta. is greater than angle .alpha., as illustratively shown in FIG. 7B, to permit advancement of filter element **102** in a distal direction only.

Proximal stop **160** of guide wire **150** is flexible enough so that proximal and distal tapers **163** and **164** may assume substantially flat configurations, i.e., substantially parallel to longitudinal axis **170** of guide wire **150**, when elastomeric cone **106** and capture ring **104** are advanced distally over bent region **161**. Once filter element **102** is advanced distally over proximal stop **160**, proximal and distal tapers **163** and **164** return to the bent configurations depicted in FIG. 7A.

Apparatus **140** of FIG. 7 preferably is deployed in the manner described hereinabove with respect to apparatus **10** of FIGS. 1-3, except as noted below. In a first step, guide wire **150** is percutaneously and transluminally inserted until proximal stop **160** is disposed just distal of a stenosis. In a next step, filter element **102** is advanced along guide wire **150** in a contracted state, preferably being contracted within lumen **24** of catheter **21**, as described hereinabove with respect to FIG. 3B. Push tube **25** of FIG. 3B then is advanced distally so that a distal end of push tube **25** abuts capture ring **104** and advances filter element **102** distally.

As push tube **25** advances filter element **102**, elastomeric cone **106** is pushed distally over proximal taper **163** of guide wire **150**. Proximal and distal tapers **163** and **164** may assume substantially flat configurations, i.e., substantially parallel to longitudinal axis **170**, to facilitate distal advancement of elastomeric cone **106**. As push tube **25** further is advanced distally, capture ring **104** then is advanced over proximal stop **160** in the same manner as elastomeric cone **106**.

Once filter element **102** is disposed between proximal stop **160** and distal region **152**, filter element **102** is deployed, as described hereinabove. Filter element **102** preferably is provided in a central position between proximal stop **160** and distal region **152**, as shown in FIG. 7A, by proximally retracting or distally advancing guide wire **150** under fluoroscopy. If it becomes necessary to advance filter element **102** distally during a medical procedure, guide wire **150** may be advanced distally until distal taper **164** of proximal stop **160** abuts capture ring **104** and gently urges filter element **102** distally. Proximal stop **160** of guide wire **150** is configured to retain the bent shape depicted in FIG. 7 as distal taper **164** urges filter element **102** distally. Upon completion of the medical procedure, catheter **21** may be advanced distally over guide wire **150** to cause filter element **102** and any emboli captured therein to be removed via the catheter, as described in detail hereinabove with respect to FIG. 3E.

## 12

While preferred illustrative embodiments of the invention are described above, it will be apparent to one skilled in the art that various changes and modifications may be made. The appended claims are intended to cover all such changes and modifications that fall within the true spirit and scope of the invention.

What is claimed is:

1. Apparatus for filtering emboli from blood flowing through a vessel, the apparatus comprising:

a guide wire having proximal and distal regions, and proximal and distal stops on the distal region; and

a filter element configured to rotate and translate on the guide wire between the proximal and distal stops,

wherein an elastomeric element of the filter element and the proximal stop are adapted to permit advancement of the filter element from the proximal region by passing in vivo over the proximal stop, the proximal stop and the elastomeric element thereafter prohibiting proximal retraction of the filter element over the proximal stop;

and

wherein the proximal stop has proximal and distal ends, the distal end having a greater radial dimension than the guide wire and the proximal end having a radial dimension approximately equal to the guide wire with a proximally decreasing taper between the distal end and the proximal end.

2. The apparatus of claim 1, wherein the distal stop limits translation of the filter element in a distal direction.

3. The apparatus of claim 1, wherein the proximal stop and distal stop are spaced apart such a distance that the filter element, when deployed therebetween, will not be disturbed by incidental longitudinal movements of the guide wire.

4. The apparatus of claim 1, wherein the proximal stop is configured to abut against a proximal portion of the filter element, after the filter element is moved to the distal region, when the guide wire is advanced.

5. The apparatus of claim 1, wherein the filter element further comprises an elastomeric capture ring;

a plurality of self-expanding struts coupled between the capture ring and the distal element; and

a filter sac disposed about a portion of the self-expanding struts,

wherein the elastomeric capture ring and the elastomeric distal element are capable of being advanced over the proximal stop.

6. The apparatus of claim 5, wherein the elastomeric capture ring and the elastomeric distal element are sized to substantially seal against the guide wire when the filter is deployed about the distal region of the guide wire.

7. A method for filtering emboli from blood flowing through a vessel, the method comprising:

providing an apparatus comprising a guide wire having a distal region including a distal stop, a proximal stop disposed proximal the distal stop, and a filter element disposed for translation on the guide wire, an elastomeric element of the filter element and proximal stop being adapted to prohibit proximal retraction of the filter element over the proximal stop, the proximal stop comprising proximal and distal ends, the distal end having a greater radial dimension than the guide wire and the proximal end having a radial dimension approximately equal to the guide wire with a proximally decreasing taper between the distal end and the proximal end, the method further comprising:

transluminally inserting the guide wire into a vessel; distally advancing the elastomeric element of the filter element in a contracted state over the proximal stop; and

**13**

deploying the filter element, proximal of the distal stop, to engage a wall of the vessel and filter emboli out of blood flowing through the vessel.

**8.** The method of claim 7 further comprising advancing a treatment device along the guide wire to treat a portion of the vessel proximal of the location of the filter element, wherein incidental rotation or translation of the guide wire relative to the filter element does not displace the filter element.

**9.** The method of claim 7 further comprising a step of, after use of the treatment device is completed, pulling the guide

**14**

wire proximally so that the distal stop engages the filter element and causes the filter element to return to the contracted state.

**10.** The apparatus of claim 1, wherein the elastomeric distal element are sized to substantially seal against the guide wire when the filter is deployed about the distal region of the guide wire.

\* \* \* \* \*