



US008175645B2

(12) **United States Patent**
Evans et al.

(10) **Patent No.:** **US 8,175,645 B2**
(45) **Date of Patent:** **May 8, 2012**

(54) **SYSTEM AND METHOD FOR MODIFYING A DEVICE PROFILE**

(75) Inventors: **James Evans**, Apex, NC (US); **Richard J. Walsh**, Raleigh, NC (US); **Alfredo C. Issa**, Apex, NC (US)

(73) Assignee: **Qurio Holdings, Inc.**, Raleigh, NC (US)

(*) Notice: Subject to any disclaimer, the term of this patent is extended or adjusted under 35 U.S.C. 154(b) by 914 days.

(21) Appl. No.: **11/451,225**

(22) Filed: **Jun. 12, 2006**

(65) **Prior Publication Data**

US 2007/0288543 A1 Dec. 13, 2007

(51) **Int. Cl.**

H04M 1/00 (2006.01)

(52) **U.S. Cl.** **455/557**; 455/414.1; 455/414.2; 455/414.3; 455/436; 455/435.1; 709/248

(58) **Field of Classification Search** 455/414.1–414.3, 455/435.1, 436; 709/248

See application file for complete search history.

(56) **References Cited**

U.S. PATENT DOCUMENTS

5,742,905	A *	4/1998	Pepe et al.	455/461
7,124,203	B2 *	10/2006	Joshi et al.	709/248
7,551,922	B2 *	6/2009	Roskowski et al.	455/423
2002/0198004	A1 *	12/2002	Heie et al.	455/456
2003/0187984	A1	10/2003	Banavar et al.	
2004/0168121	A1	8/2004	Matz	
2004/0235464	A1	11/2004	Korkalo et al.	
2005/0188056	A1 *	8/2005	Kangas et al.	709/218

FOREIGN PATENT DOCUMENTS

EP 1494419 A1 1/2005

OTHER PUBLICATIONS

W3C Composite Capability, <http://www.w3.org/TR/2004/REC-CCPP-struct-vocab-20040115/>.

PC Magazine, <http://www.pcmag.com/article2/0,1759,1619375,00.asp>.

Yasuda, Kinuko et al., "Effects and Performance of Content Negotiation Based on CC/PP," Lecture Notes in Computer Science, vol. 1987/2001, Jan. 8, 2001, pp. 53-64.

Extended European Search Report issued Mar. 3, 2011, for European Application No. 07762258.7, 7 pages.

International Search Report mailed Oct. 14, 2008, for PCT/US07/69335, 11 pages.

* cited by examiner

Primary Examiner — Olumide T Ajibade Akonai

Assistant Examiner — Randy Peaches

(74) *Attorney, Agent, or Firm* — Withrow & Terranova, PLLC

(57) **ABSTRACT**

The present invention provides a system and method for modifying a profile of a user device prior to sending the profile to a destination server, wherein the destination server customizes content provided to the user device based on the modified profile. In general, the profile of the user device may include information identifying capabilities of the user device, user preferences, and demographic information regarding a user of the user device. At either the user device or a mediating server interconnecting the user device and the destination server, the profile of the user device is modified based upon one or more rules to provide the modified profile. The modified profile is then provided to the destination server, which customizes content provided to the user device based on the modified profile.

25 Claims, 8 Drawing Sheets

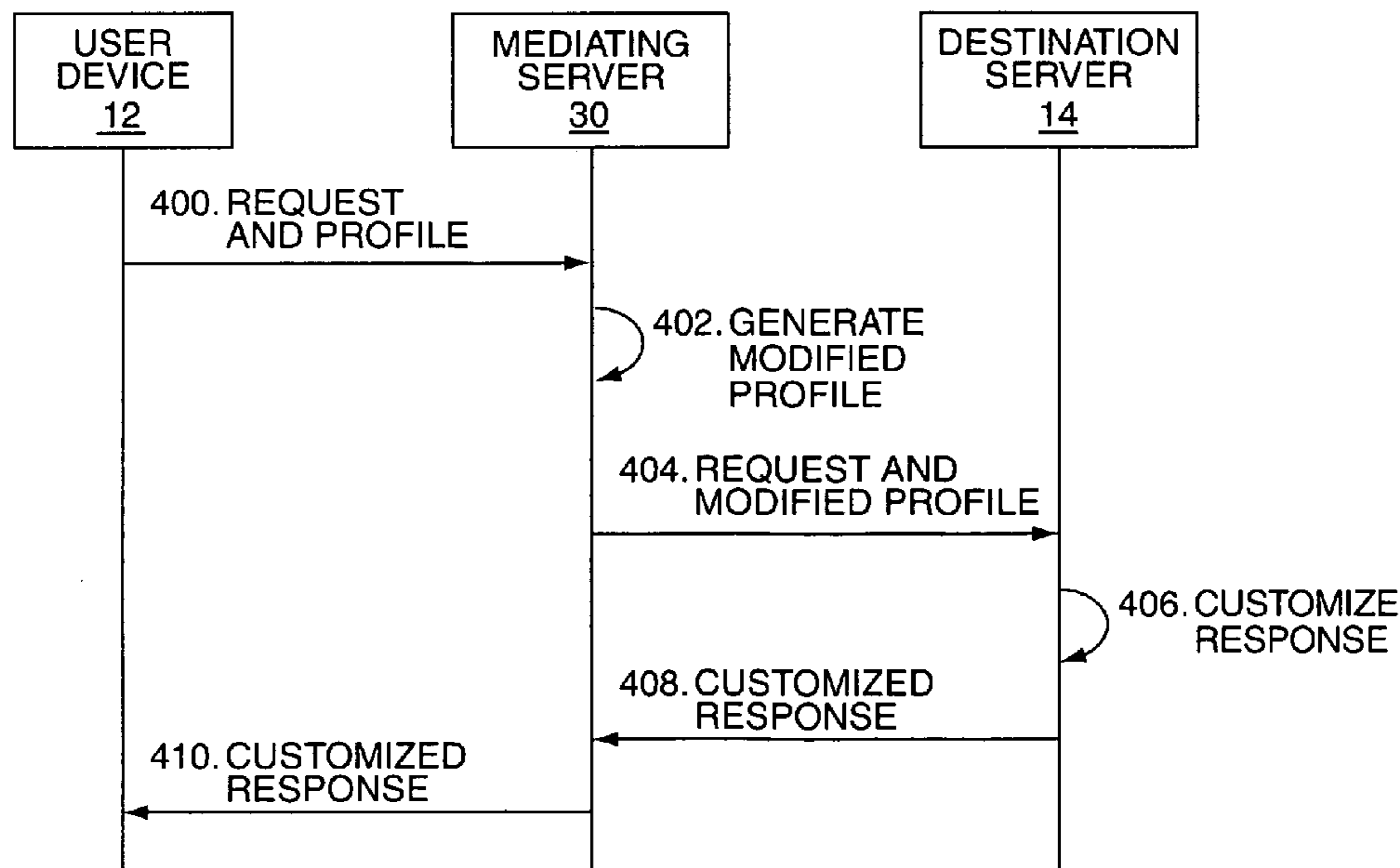

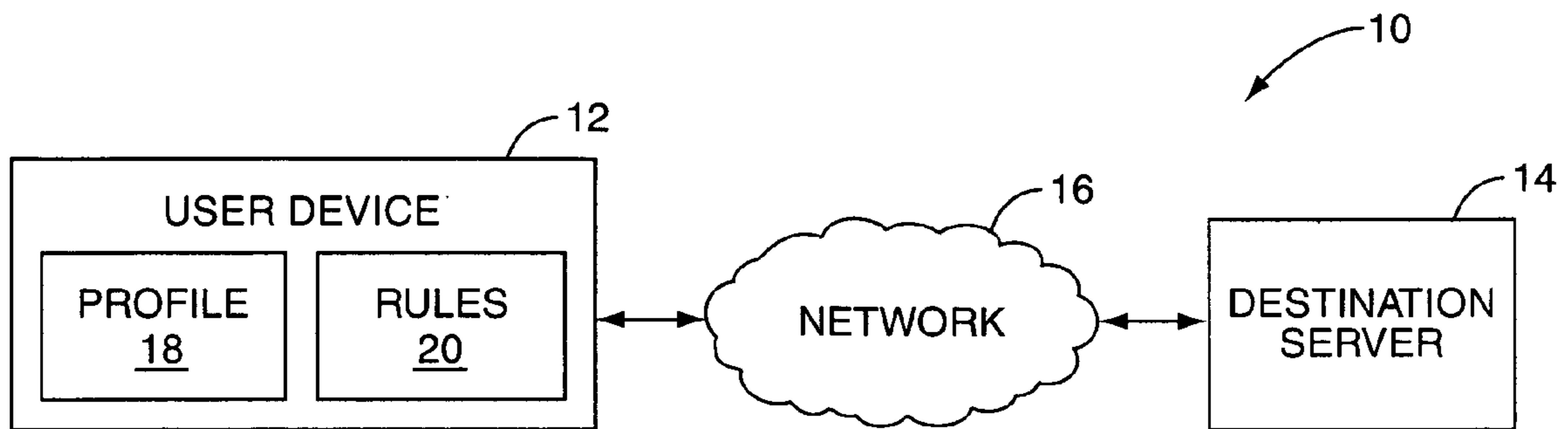

FIG. 1

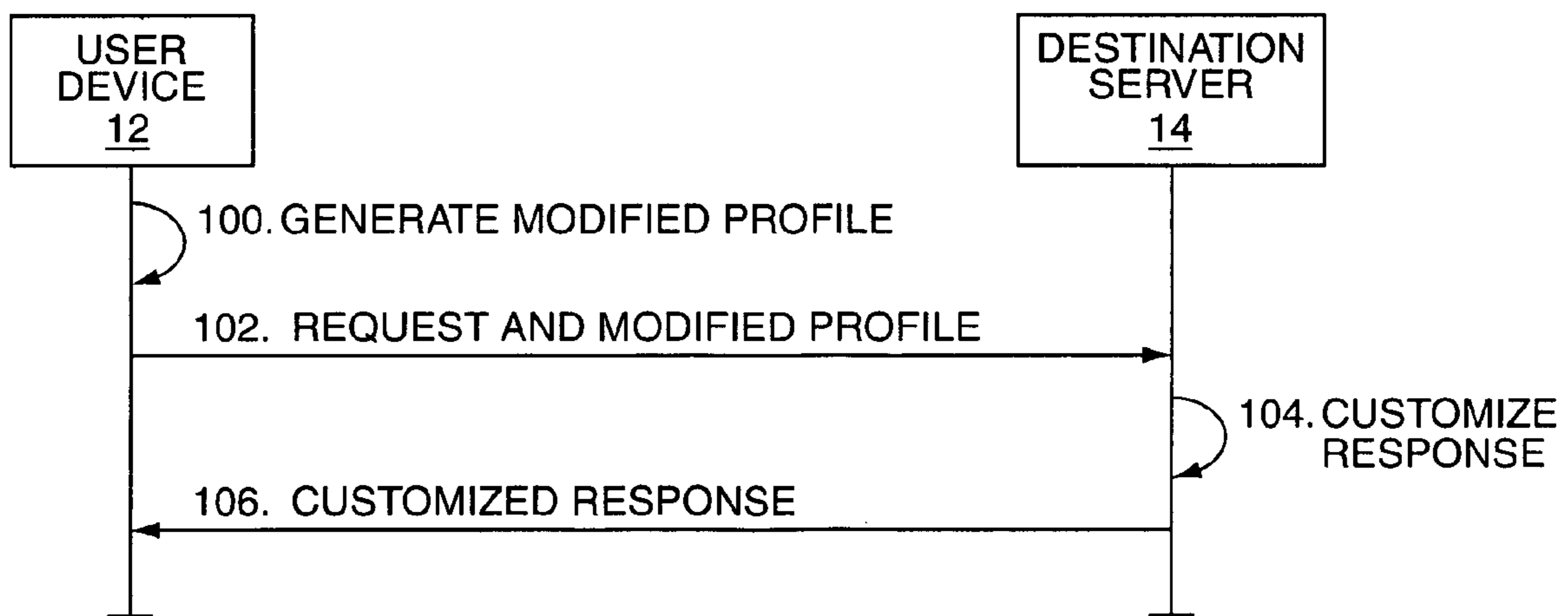

FIG. 2

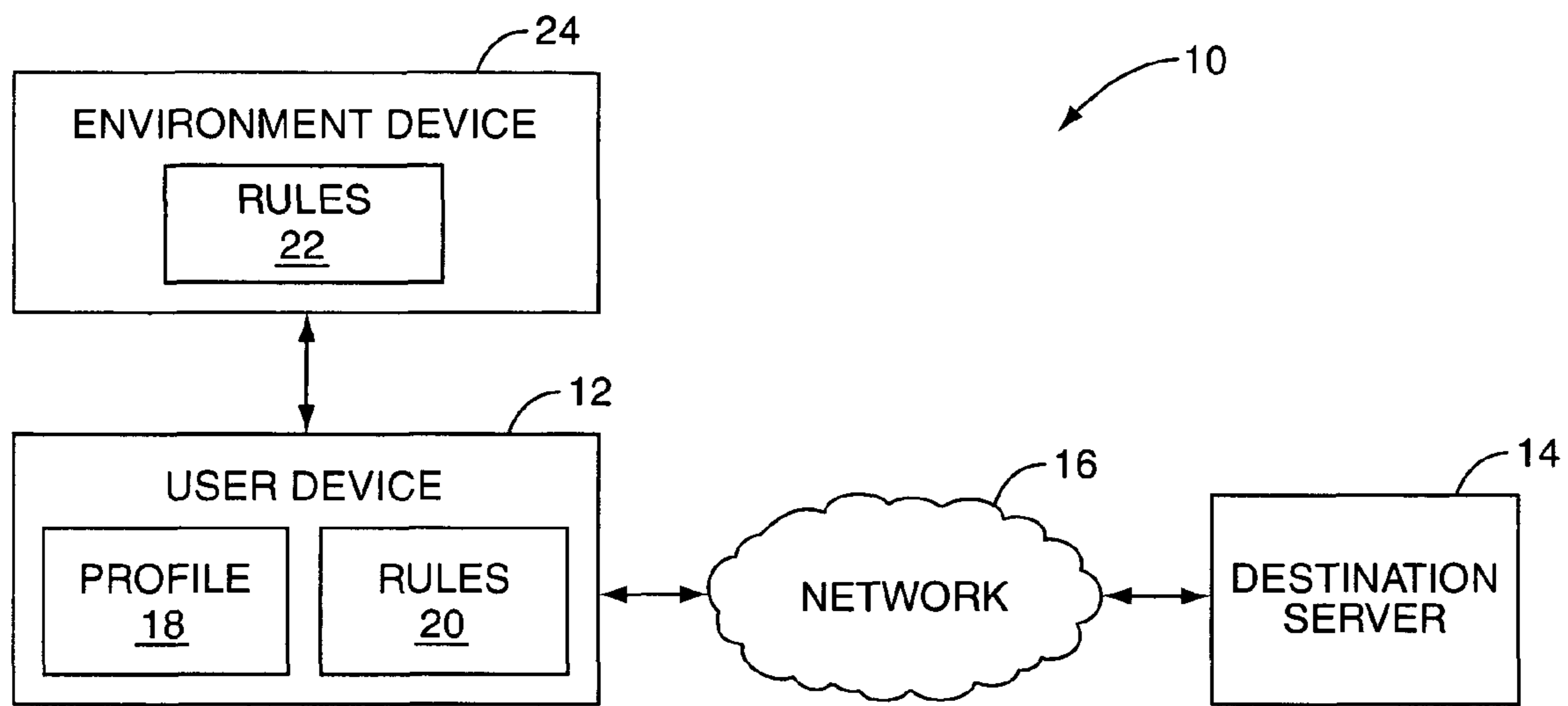

FIG. 3

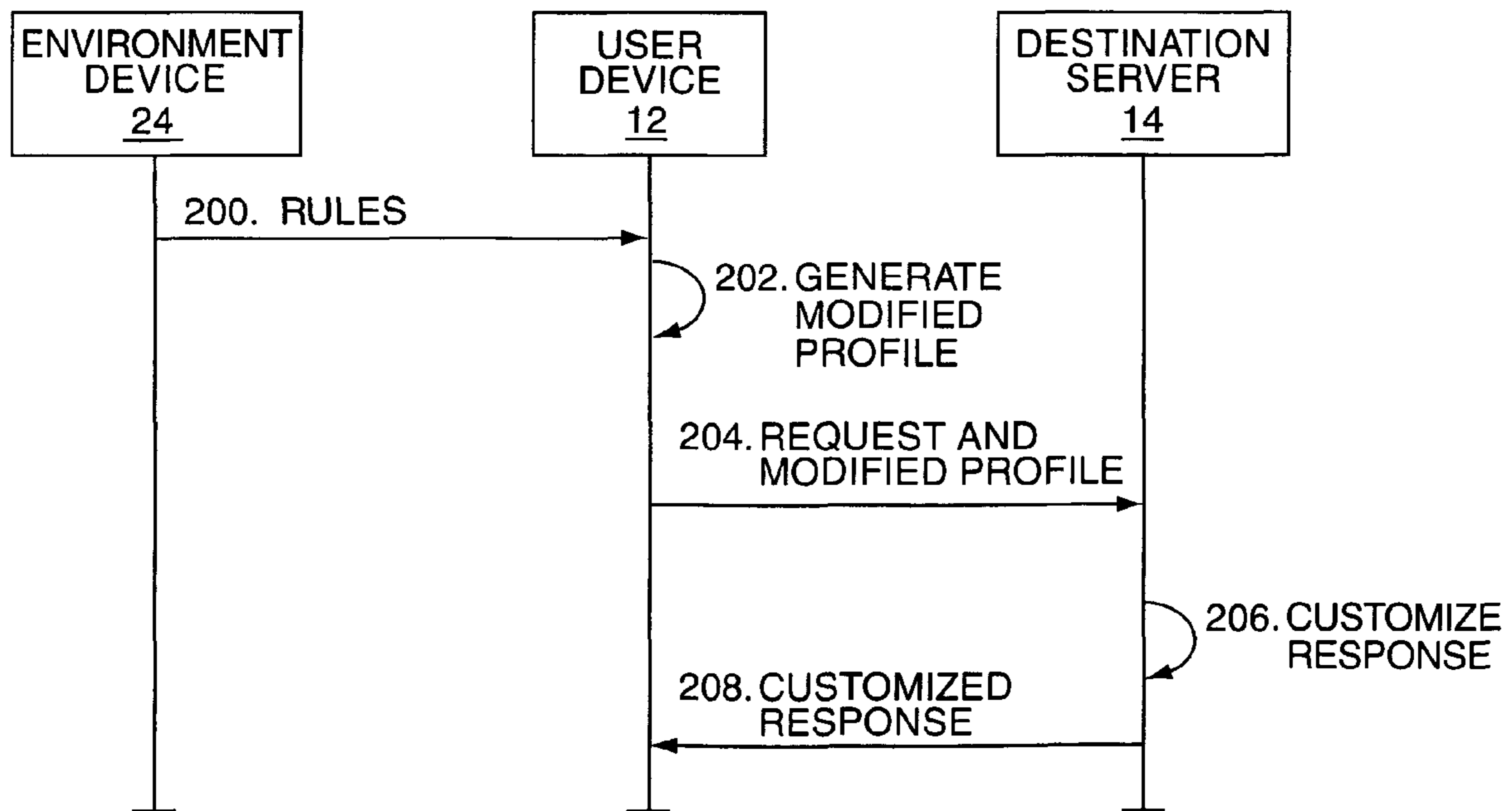

FIG. 4

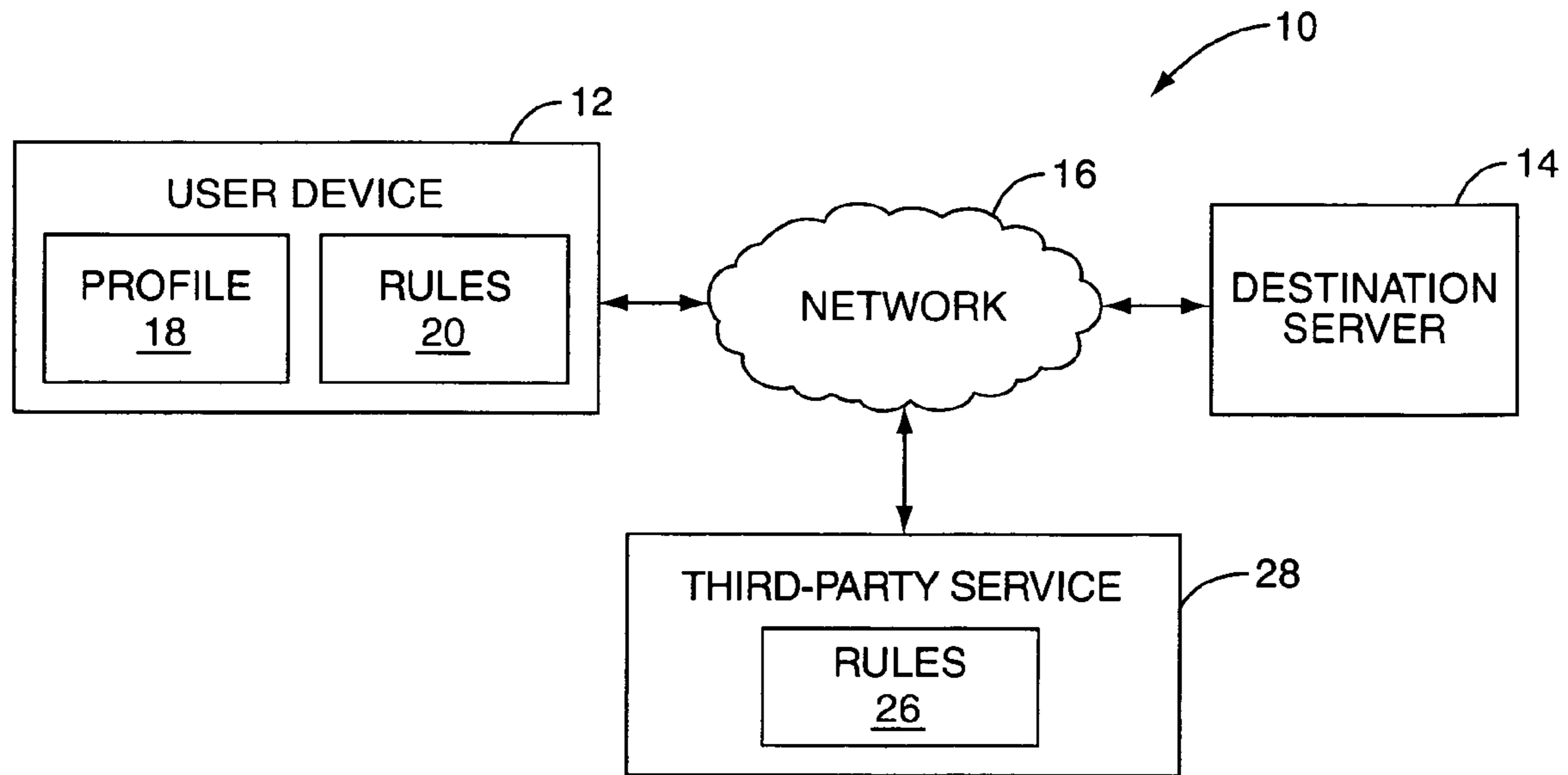

FIG. 5

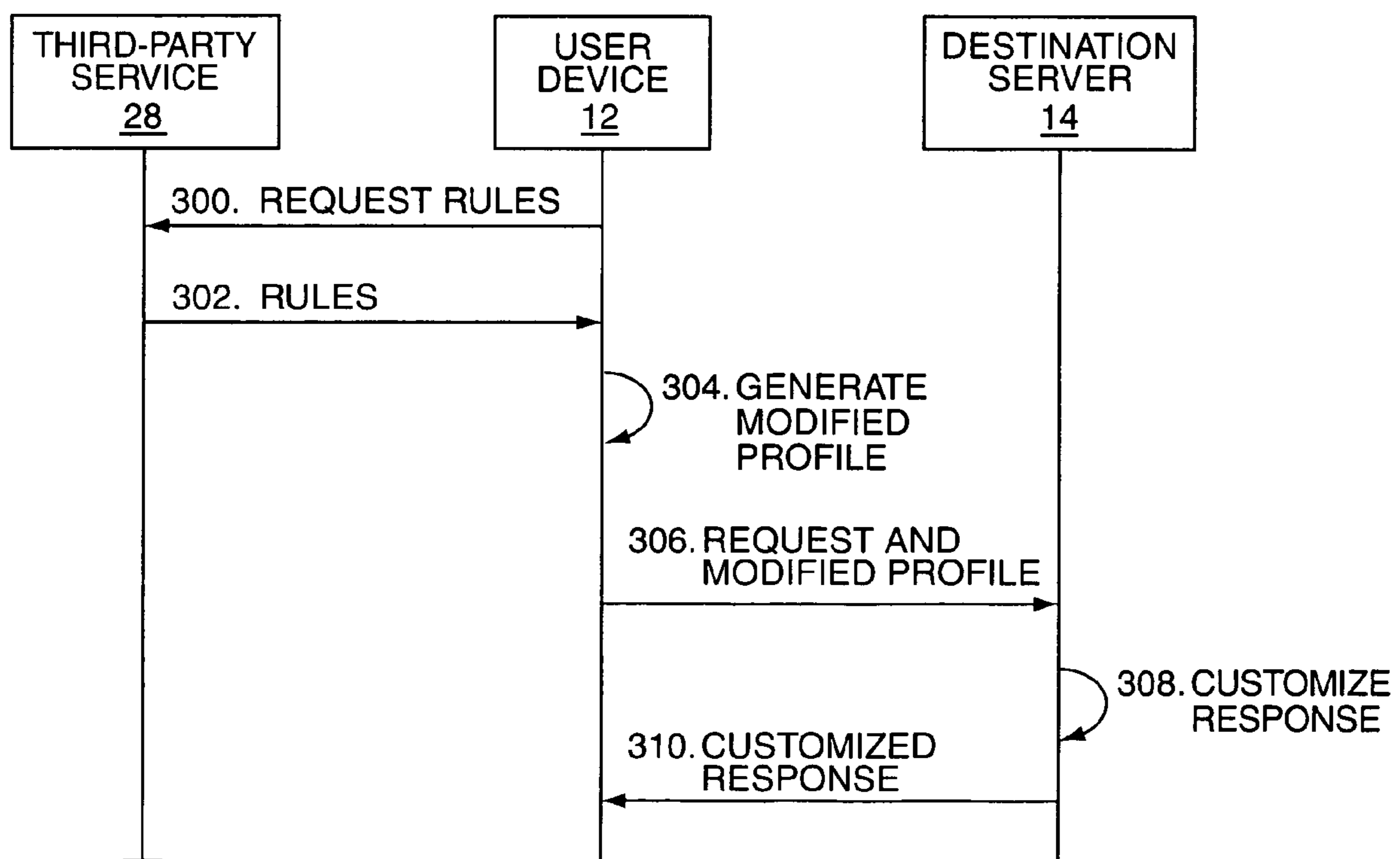

FIG. 6

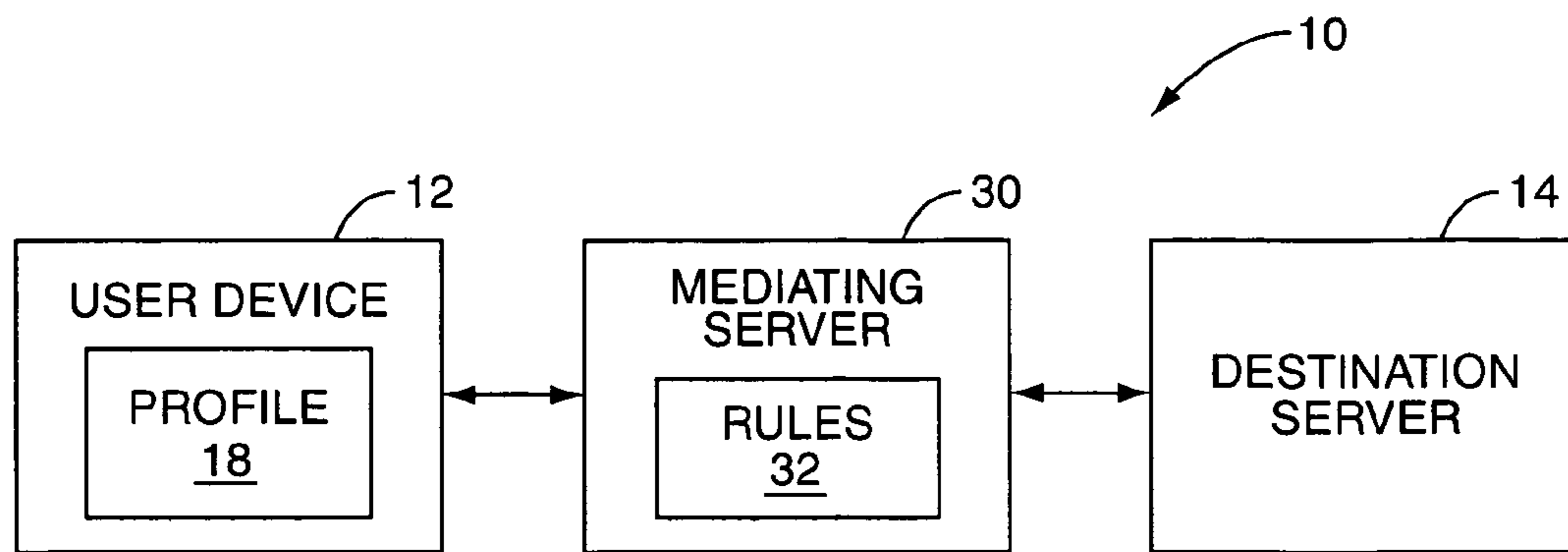

FIG. 7

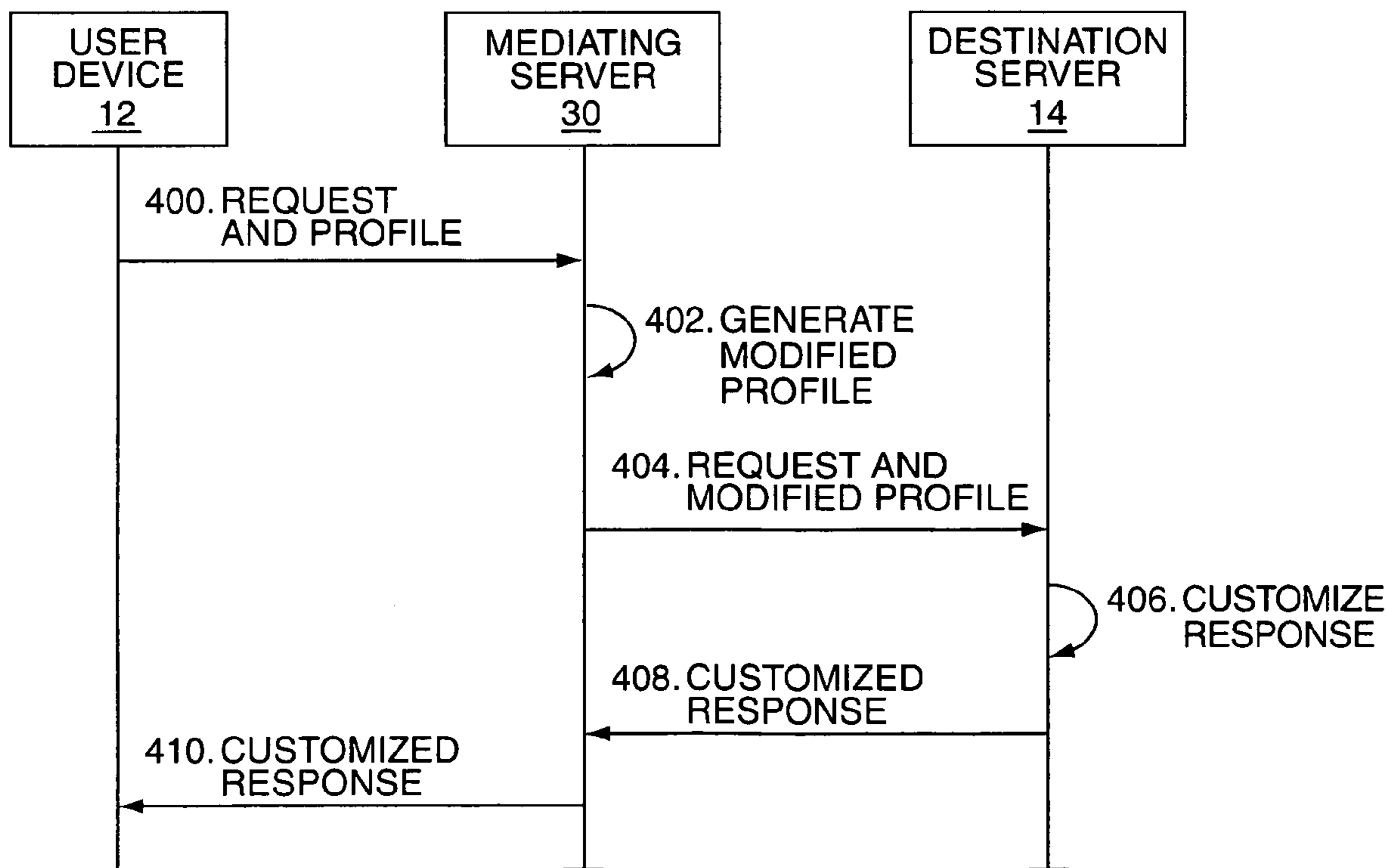

FIG. 8

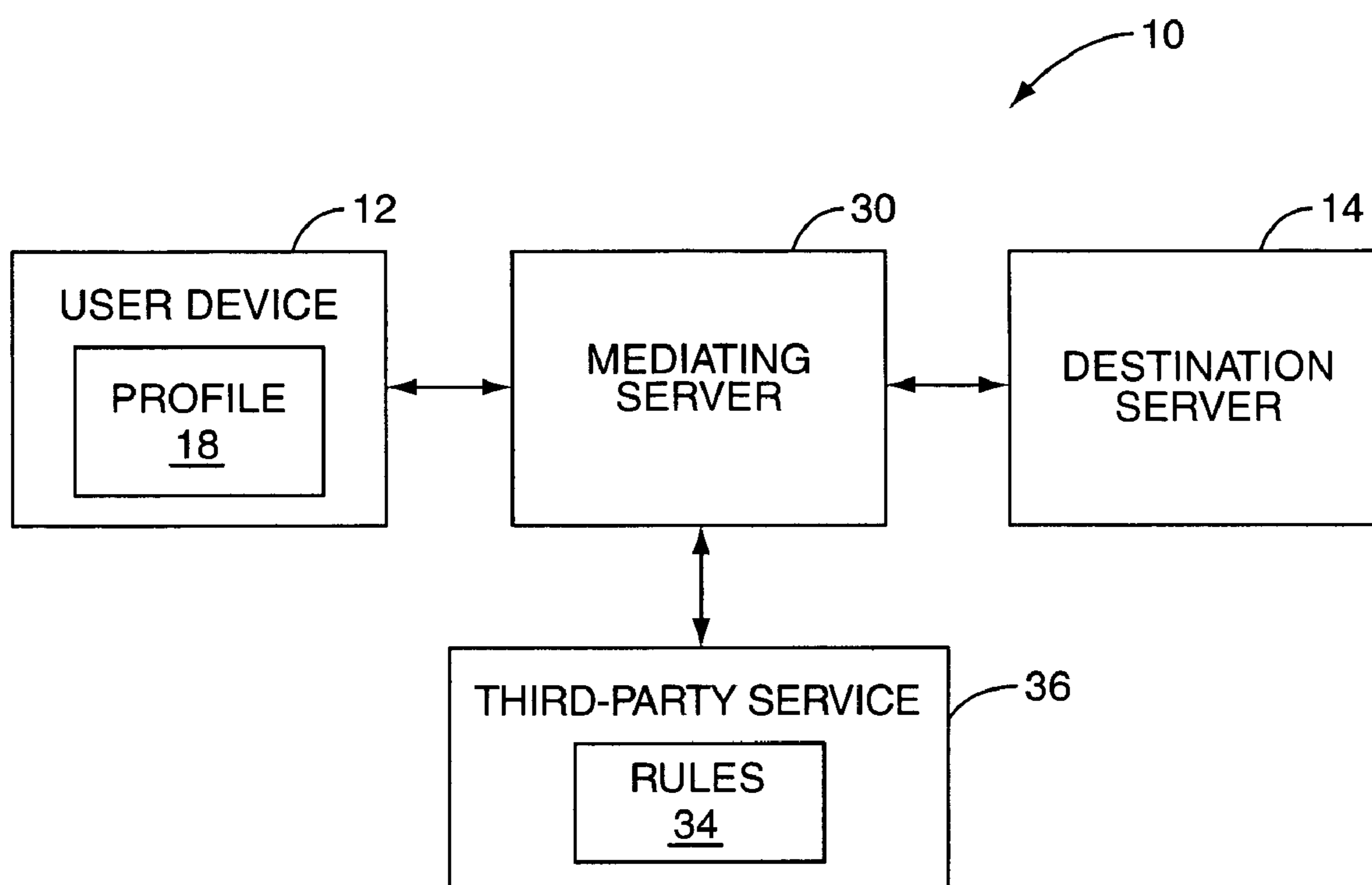

FIG. 9

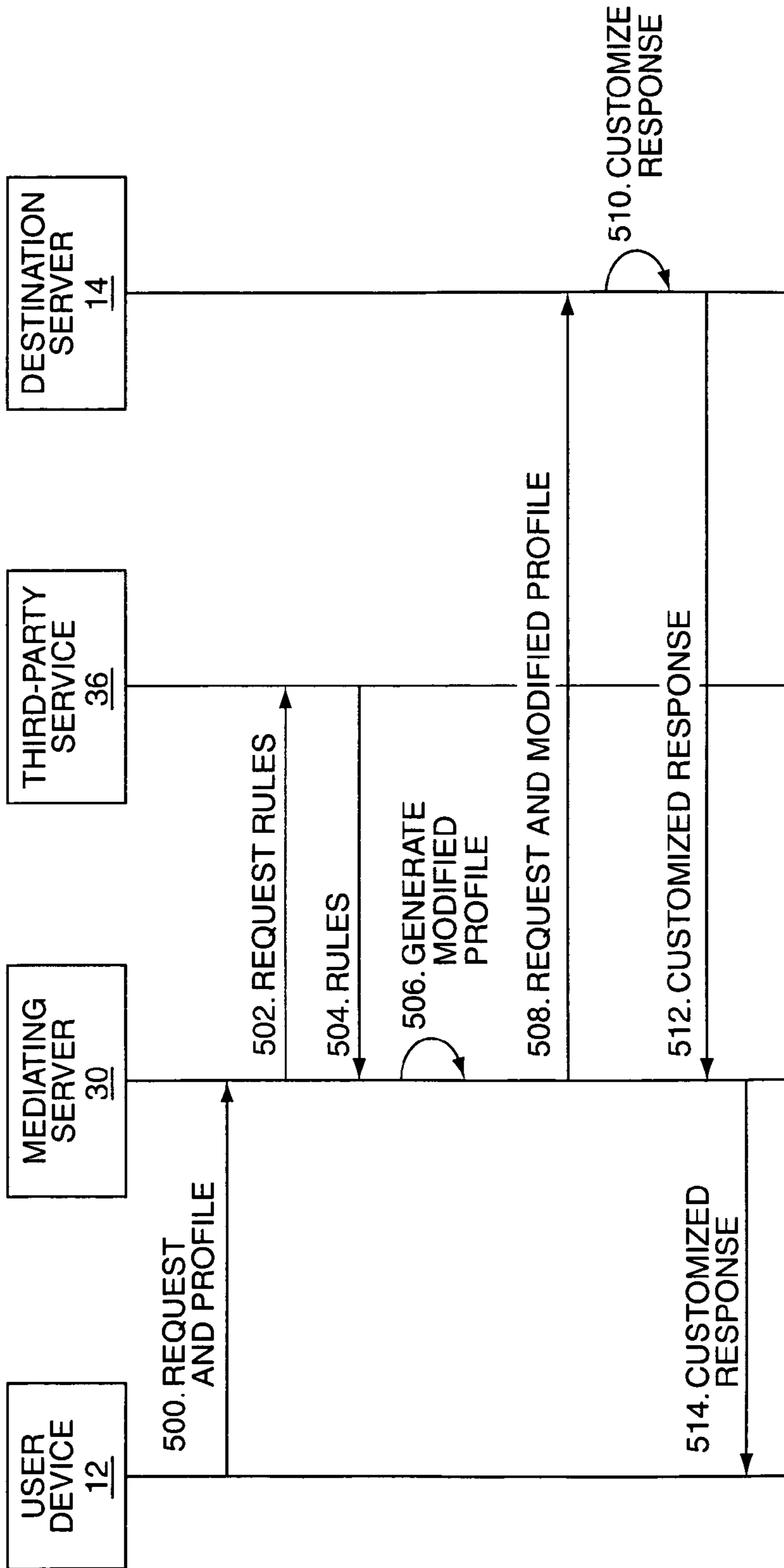

FIG. 10

12

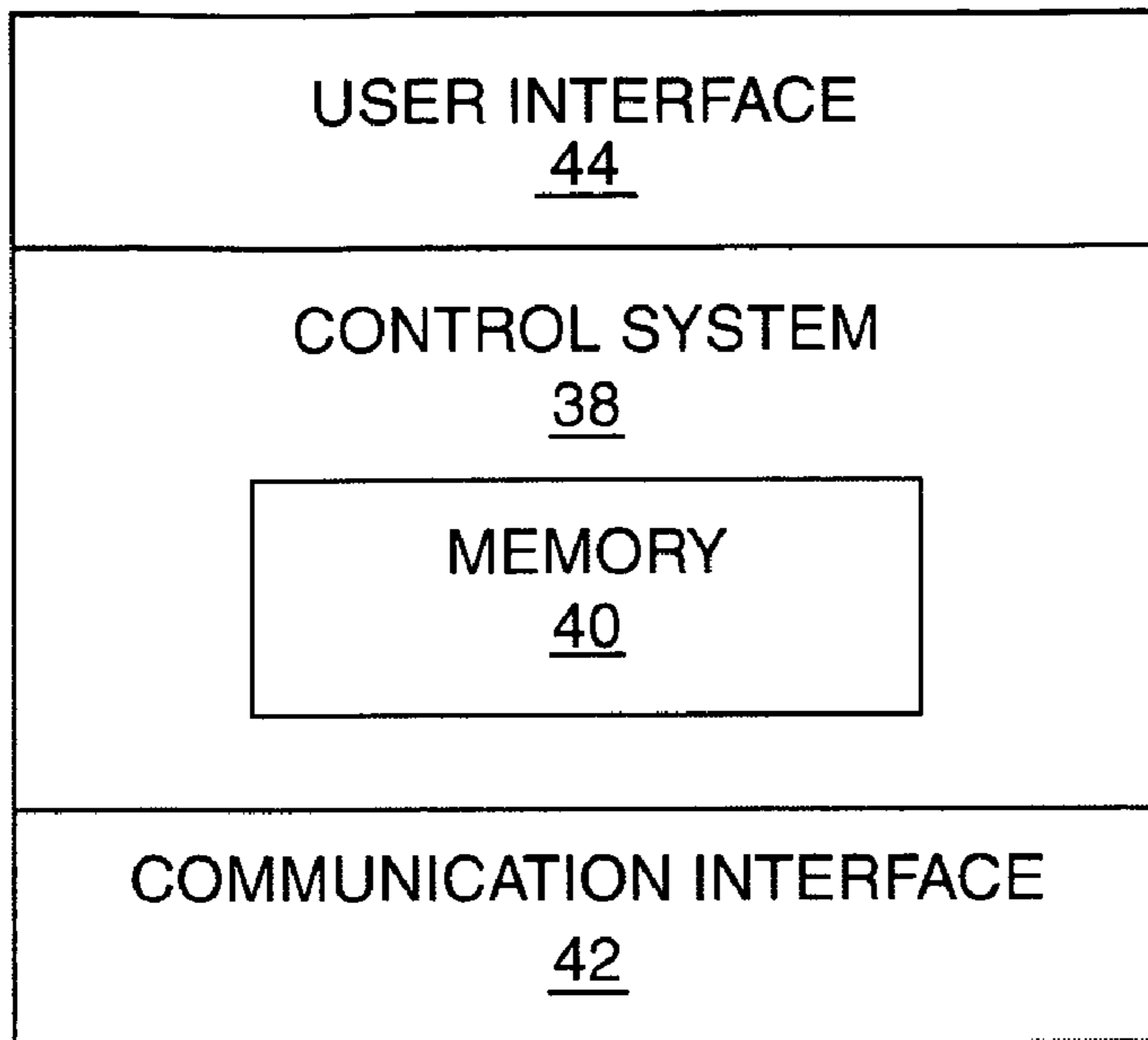

FIG. 11

14

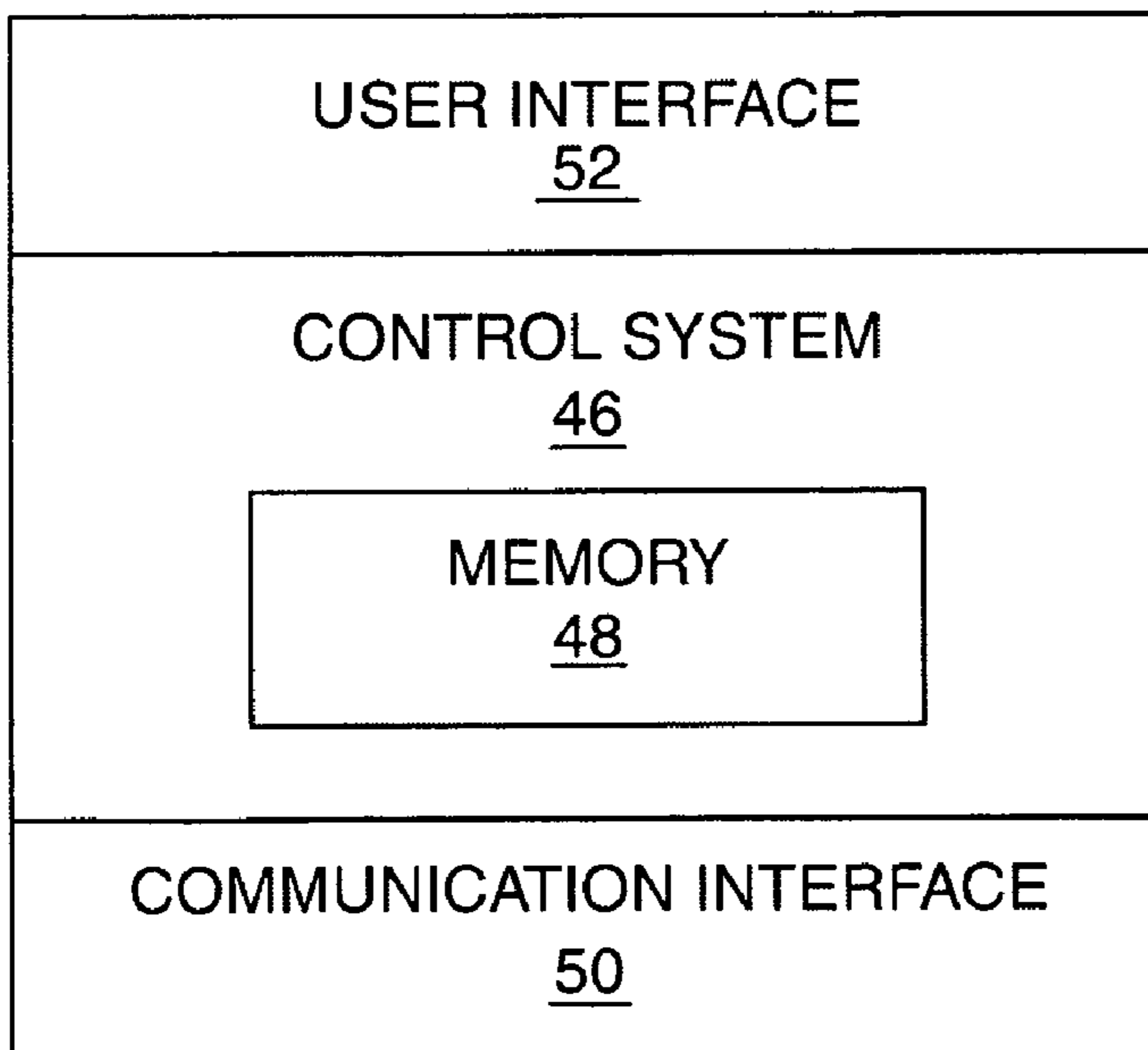

FIG. 12

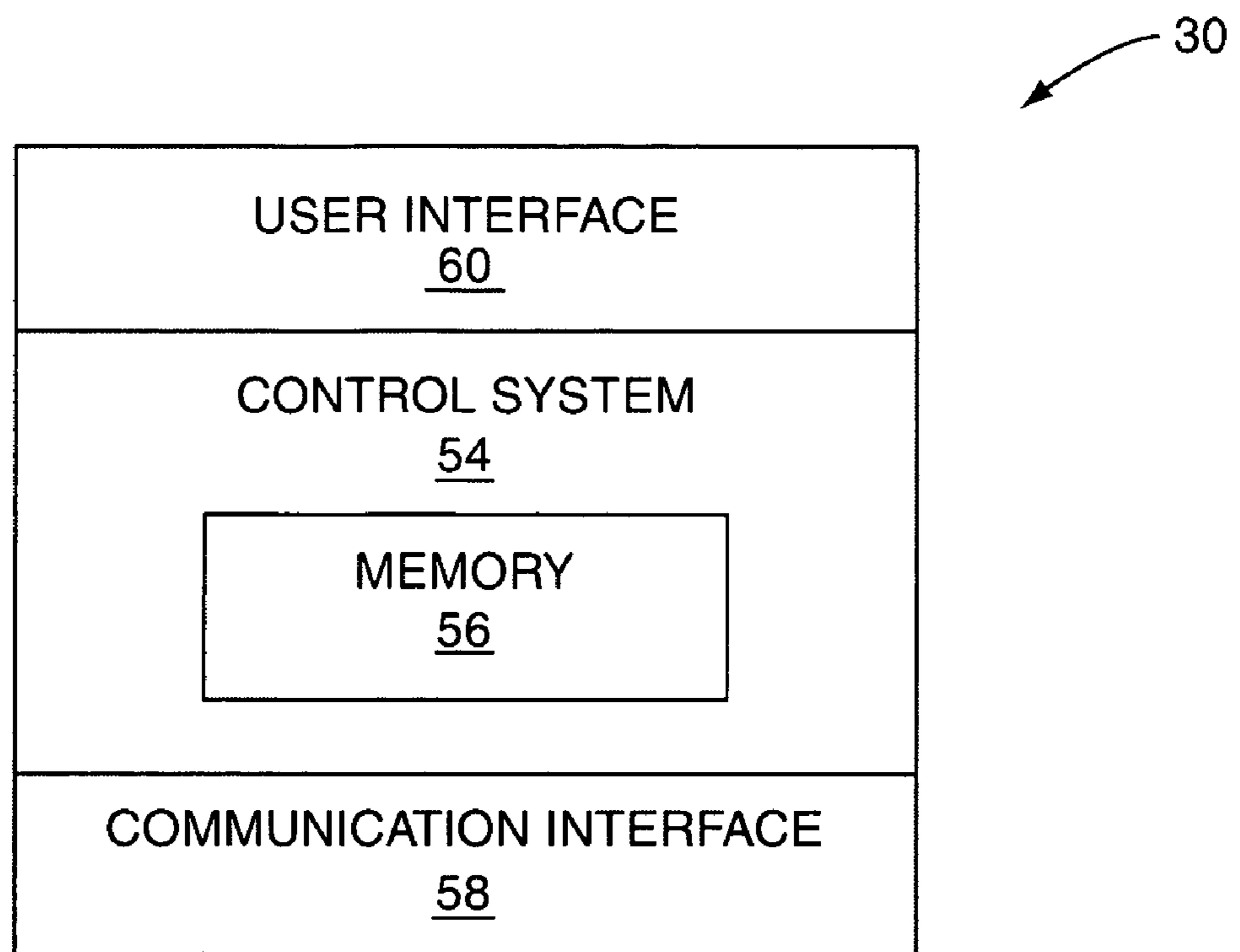

FIG. 13

1**SYSTEM AND METHOD FOR MODIFYING A
DEVICE PROFILE**

FIELD OF THE INVENTION

The present invention relates to customizing content provided to a user device based on a profile of the device, and more particularly relates to modifying the profile of a user device before providing the profile to a content provider.

BACKGROUND OF THE INVENTION

As a result of the proliferation of mobile devices having access to the Internet and the vastly varying capabilities of these mobile devices, the World Wide Web Consortium (W3C) has promulgated a Composite Capability/Preference Profile (CC/PP) standard enabling customization of web content based on the capabilities and user preferences of a recipient device. More specifically, according to the CC/PP standard, a profile identifying the capabilities and user preferences of a device is created. The profile may be provided to web content providers and used to customize the web content provided to the device. For example, the profile of a device may indicate that the display of the device is 320×200 pixels. As a result, the web content provider may reduce the size of, for example, an image such that the image fits the display of the device.

However, providing device profiles to the web content provider raises security and privacy issues. Many users may desire not to share at least some of the information contained in the device profile with web content providers. Thus, there is a need for a system and method for addressing these security and privacy concerns.

In addition, both the users of the devices and operators of locations in which the devices are present may desire to control the use, or non-use, of certain device capabilities. For example, a user may prefer that no audio content be provided to his or her device after 11:00 p.m. Likewise, the operator of a library may desire to prevent audio content from being played by devices present in the library. Thus, there remains a need for a system and method for controlling the use of the particular device capabilities.

SUMMARY OF THE INVENTION

The present invention provides a system and method for modifying a profile of a user device prior to sending the profile to a destination server, wherein the destination server customizes content provided to the user device based on the modified profile. In general, the profile of the user device may include information identifying capabilities of the user device, user preferences, and demographic information regarding a user of the user device. When sending the profile to the destination server, the profile of the user device is modified by either the user device or a mediating server interconnecting the user device and the destination server based upon one or more rules. Based on the rules, capabilities, such as audio capabilities, identified in the profile may be modified by either removing capabilities from or adding capabilities to the profile in order to control the use of the capabilities. In addition or alternatively, the rules may direct the user device or the mediating server to remove information such as all or a portion of the user preferences and the demographic information from the profile when providing the profile to an identified destination server. The modified profile is provided to the destination server, which customizes content provided to the user device based on the modified profile.

2

Those skilled in the art will appreciate the scope of the present invention and realize additional aspects thereof after reading the following detailed description of the preferred embodiments in association with the accompanying drawing figures.

BRIEF DESCRIPTION OF THE DRAWING
FIGURES

The accompanying drawing figures incorporated in and forming a part of this specification illustrate several aspects of the invention, and together with the description serve to explain the principles of the invention.

FIG. 1 illustrates a system for modifying a profile of a user device prior to providing the profile to a destination server according to one embodiment of the present invention;

FIG. 2 illustrates the operation of the system of FIG. 1;

FIG. 3 illustrates a system for modifying a profile of a user device prior to providing the profile to a destination server according to a second embodiment of the present invention;

FIG. 4 illustrates the operation of the system of FIG. 3;

FIG. 5 illustrates a system for modifying a profile of a user device prior to providing the profile to a destination server according to a third embodiment of the present invention;

FIG. 6 illustrates the operation of the system of FIG. 5;

FIG. 7 illustrates a system for modifying a profile of a user device prior to providing the profile to a destination server according to a fourth embodiment of the present invention;

FIG. 8 illustrates the operation of the system of FIG. 7;

FIG. 9 illustrates a system for modifying a profile of a user device prior to providing the profile to a destination server according to a fifth embodiment of the present invention;

FIG. 10 illustrates the operation of the system of FIG. 9;

FIG. 11 is a block diagram of a user device according to one embodiment of the present invention;

FIG. 12 is a block diagram of a destination server according to one embodiment of the present invention; and

FIG. 13 is a block diagram of a mediating server according to one embodiment of the present invention.

DETAILED DESCRIPTION OF THE PREFERRED
EMBODIMENTS

The embodiments set forth below represent the necessary information to enable those skilled in the art to practice the invention and illustrate the best mode of practicing the invention. Upon reading the following description in light of the accompanying drawing figures, those skilled in the art will understand the concepts of the invention and will recognize applications of these concepts not particularly addressed herein. It should be understood that these concepts and applications fall within the scope of the disclosure and the accompanying claims.

FIG. 1 illustrates a system 10 operating according to one embodiment of the present invention. In general, the system 10 includes a user device 12 and a destination server 14 communicatively coupled by a network 16, which may be a distributed, public network such as the Internet. In operation, the user device 12 modifies a profile 18 of the user device 12 using rules 20 and provides the modified profile to the destination server 14. At the same time or at some time thereafter, the user device 12 requests content from the destination server 14. The content may be, for example, a web page, multimedia content, or the like. Based on the modified profile, the destination server 14 generates a customized response and provides the customized response to the user device 12.

The user device **12** may be a personal computer; a mobile device such as, but not limited to, a mobile telephone or a Personal Digital Assistant (PDA); or the like. The user device **12** stores the profile **18** and the rules **20**. The profile **18** may be automatically generated by the user device **12** and includes metadata, or information, describing the user device **12**. More specifically, the profile **18** may include an Internet Protocol (IP) address of the user device **12** or the like, a device identifier (ID) of the user device **12**, a user agent of the user device **12**, information identifying the capabilities of the user device **12**, user preferences, and demographic information.

The user agent is an indicator of the program being used to access content such as, for example, Microsoft Internet Explorer. By knowing the user agent, certain capabilities may be inferred. For example, if the user agent is Microsoft Internet Explorer, it can be inferred that the user agent is a web browser that can display images, interpret HTML, and the like. The device ID could be either a globally unique ID or a make/model type ID. The device capabilities include hardware specifications for the user device **12**. For example, the device capabilities may indicate that the user device **12** has a color display having a 320×200 resolution, can produce stereo sound, has 1 MB of storage space, and has audio, video, and image capture capabilities. Further, the device capabilities may include capabilities of the audio, video, and image capture function such as maximum resolution, possible file formats, bitrate, and the like.

The user preferences may include various user preferences. For example, if the user device **12** is a mobile telephone, or has mobile telephone capabilities, the user may prefer that the user device **12** is set to vibrate instead of ring or answer-on-open rather than push-talk-to-answer. The user preferences may also include preferences for font face and size, color scheme, background image, or the like. In addition, the user preferences may include other preferences unrelated to the user device **12**, such as, for example, the user's favorite pizza topping. It should be noted that the user preferences could store virtually any type of user preferences which may or may not be related to the user device **12**.

The demographic information may include, but is not limited to, a name, mailing address, age, gender, marital status, and the like for a user of the user device **12**. In an exemplary embodiment, the profile **18** may be a Composite Capability/Preference Profile (CC/PP) as disclosed in the CC/PP recommendation of the World Wide Web Consortium (W3C) entitled "Composite Capabilities/Preference Profiles (CC/PP): Structure and Vocabularies 1.0," which was published Jan. 15, 2004 and can be found at <http://www.w3.org/TR/2004/REC-CCPP-struct-vocab-20040115/>.

In this embodiment, the rules **20** are rules defined by the user of the user device **12** that are used to modify the profile **18** of the user device **12** to control content provided to the user device **12**. Based on the rules **20**, the user device **12** operates to modify, or filter, the profile **18**. The rules **20** are formed using one or more criterion such as, but not limited to, location, time, destination, resource availability, or the like, or any combination thereof. Regarding time, the rules **20** may include rules defined by the user of the user device **12** based on, at least in part, the current time of day, day of the week, date, or any combination thereof. For example, the rules **20** may include a rule that removes audio capabilities from the profile or modifies the profile to indicate that the user device **12** has no audio capabilities after 11:00 p.m. such that no audio content is provided to the user device **12** after 11:00 p.m. As another example, the rules **20** may include a rule that adds audio capabilities to the profile or modifies the profile to indicate that the user device **12** has audio capabilities when

another user device is associated with the user device **12** and can be used to play or consume audio content.

Regarding location, the rules **20** may include rules defined by the user of the user device **12** based on, at least in part, a current location of the device. As an example, a user may define a location named "Library" and create a rule that removes audio capabilities from the profile or modifies the profile to indicate that the user device **12** has no audio capabilities when the user device **12** is at the location named "Library."

The location of the user device **12** may be determined based on Global Positioning System (GPS) coordinates, selected by the user of the user device **12**, or provided to the user device **12** from a device associated with the location. More specifically, in one embodiment, the user device **12** may be equipped with a GPS receiver or the like. The user may define a location, such as the location "Library," by entering the GPS coordinates of the location; by entering an address of the location, wherein the GPS coordinates may be determined or obtained for the location based on the address; or by using the coordinates from the GPS receiver while the user device **12** is present at the location. Thereafter, the user device **12** may determine whether it is present at one of the defined locations based on coordinates from the GPS receiver.

If the user device **12** is not equipped with a GPS receiver or if otherwise desired, the user of the user device **12** may define locations by providing names for the locations and associating rules with the locations. Thereafter, when the user device **12** is present at one of the defined locations, the user may interact with the user device **12** to select the current location of the user device **12**. For example, the user may define a location "Library." When the user is thereafter present at the location "Library," the user may interact with the user device **12** to select the location "Library" as the current location of the user device **12**.

In yet another embodiment, the location of the user device **12** may be provided by a device associated with the location. For example, one or more local wireless communication devices may be present at the location and operate to provide the GPS coordinates of the location, the address of the location, a description of the location, or the like, or any combination thereof. The above examples of how the location of the user device **12** may be determined or obtained are not intended to be an exhaustive list and are not intended to limit the scope of the present invention.

Regarding destination, the rules **20** may include rules defined by the user of the user device **12** based on, at least in part, destination. More specifically, the user may identify destination servers, such as the destination server **14**, using information such as, but not limited to, an IP address of the destination server **14**, a Uniform Resource Locator (URL) for the destination server **14**, or the like. Once identified, the user may define one or more rules for the destination servers. For example, the destination server **14** may host a web page with unwanted background music. As such, the user may define a rule for the destination server **14** that removes audio capabilities from the profile or modifies the profile to indicate that the user device **12** has no audio capabilities when providing the profile to the destination server **14**. As a result, when the user device **12** requests the web page from the destination server **14**, the destination server **14** may customize a response for the user device **12** based on the modified profile such that the background music, or audio content, is removed from the customized version of the web page provided to the user device **12**.

The rules **20** may also include rules for removing information from the profile **18** of the user device **12** such as the

5

demographic information, user preferences, or any portion thereof when providing the profile **18** to destination servers, such as the destination server **14**. These rules may be associated with all destination servers or particular destination servers. Thus, for the destination server **14**, the rules **20** may include a rule instructing the user device **12** to remove demographic information, user preferences, or both demographic information and user preferences from the profile **18** of the user device **12** when providing the profile **18** to the destination server **14**. This may be particularly beneficial when the user of the user device **12** does not want to share private information with the destination server **14**.

Regarding resource availability, the rules **20** may include rules defined by the user of the user device **12** based on, at least in part, resource availability. These rules may alternatively or additionally be automatically created by the user device **12**. For example, the rules **20** may include a rule that removes file storage capabilities from the profile **18** or modifies the profile **18** to indicate that the user device **12** does not have file storage capabilities if the available file storage space is less than a threshold level or if the file storage space is essentially full.

The rules **20** may also include rules defined based on a combination of criteria. For example, the rules **20** may include a rule based on location and time. More specifically, a rule may be defined for a location "Movie Theater," where audio capabilities are available prior to a movie start time and removed from the profile **18** once the movie begins. As a result, when the user device **12** requests content from a destination server, such as the destination server **14**, before the movie begins, audio content may be provided to the user device **12**. However, once the movie begins, audio content may no longer be provided to the user device **12**.

FIG. **2** illustrates the operation of the system **10** of FIG. **1**. First, the user device **12** operates to generate a modified profile (step **100**). The modified profile is generated by modifying, or filtering, the profile **18** of the user device **12** using the rules **20**. A request and the modified profile are then provided to the destination server **14** via the network **16** (step **102**). While the request and the modified profile are illustrated as being provided to the destination server **14** in a single step, the present invention is not limited thereto. The manner in which the modified profile is provided to the destination server **14** may vary depending on the particular communication protocol used for communication between the user device **12** and the destination server **14**. For example, the modified profile may be provided to the destination server **14** with each request sent to the destination server **14** or provided to the destination server **14** with only a first request sent to the destination server **14**. The modified profile may be part of the request or a separate message provided prior to or after the request.

Upon receiving the request and the modified profile, the destination server **14** operates to customize the response to be provided to the user device **12** (step **104**). The response may be customized based on the capabilities of the device, user preferences, demographic information, or any combination thereof identified in the modified profile. For example, the modified profile may indicate that the user device **12** does not have audio capabilities. As such, the destination server **14** may customize the response by removing audio content. Once the customized response is generated, the destination server **14** provides the customized response to the user device **12** (step **106**).

FIG. **3** illustrates the system **10** according to a second embodiment of the present invention wherein the user device **12** obtains environment, or location, defined rules **22** from an

6

environment device **24**. The rules **22** may be used in addition to or as an alternative to the rules **20** defined by the user of the user device **12**. As such, the rules **20** are optional in this embodiment. The rules **22** are associated with the location and may be defined based on criteria such as, but not limited to, time, destination, resource availability, or the like, or any combination thereof.

In order to obtain the rules **22** from the environment device **24**, the user device **12** may be equipped with a local wireless interface operating according to a standard such as, but not limited to, the Bluetooth standard or one of the suite of IEEE 802.11 standards. When the user device **12** is at a particular location at which the environment device **24** is located, the user device **12** may receive the rules **22** from the environment device **24** by local wireless communication. The environment device **24** may be any device present at or associated with the location having a local wireless communication interface for communicating with the user device **12**.

FIG. **4** illustrates the operation of the system **10** of FIG. **3**. First, the rules **22** are provided from the environment device **24** to the user device **12** (step **200**). The rules **22** are location-based rules and are preferably defined by an operator associated with the location. For example, the operator of a library may define the rules **22** such that profiles of user devices, such as the user device **12**, present at the library are modified to remove, for example, audio capabilities. As such, the operator of the library may prevent undesirable noise in the library. In a similar fashion, for a movie theater, the rules **22** may be provided such that audio capabilities are permitted before and after but not during a movie.

The user device **12** then generates a modified profile based on the profile **18** of the user device **12**, the rules **22** from the environment device **24**, and optionally the rules **20** defined by the user of the user device **12** (step **202**). The user device **12** then provides a request and the modified profile to the destination server **14** via the network **16** (step **204**). As discussed above, while the request and the modified profile are illustrated as being provided to the destination server **14** in a single step, the present invention is not limited thereto. The manner in which the modified profile and the request are provided to the destination server **14** may vary depending on the communication protocol used for communication between the user device **12** and the destination server **14**.

Upon receiving the request and the modified profile, the destination server **14** operates to customize the response to be provided to the user device **12** (step **206**). The response may be customized based on the capabilities of the device, user preferences, demographic information, or any combination thereof identified in the modified profile. Once the customized response is generated, the destination server **14** provides the customized response to the user device **12** (step **208**).

FIG. **5** illustrates the system **10** according to a third embodiment of the present invention wherein the user device **12** obtains rules **26** from a third-party service **28**. The rules **26** may be used in addition to or as an alternative to the rules **20** defined by the user of the user device **12** and stored on the user device **12**. Note that the rules **20** are optional in this embodiment. The rules **26** may be defined by the user of the user device **12** or defined by an operator of a location at which the user device is present. As discussed above, the rules **26** may be defined based on location, time, destination, resource availability, or the like, or any combination thereof. The third-party service **28** may be, for example, a service provided by a cellular service provider, an Internet service provider, or the like. Alternatively, the third-party service **28** may be a service associated with a current location of the user device **12**.

In one embodiment, the rules 26 are defined by an operator of the location, and the user device 12 obtains information identifying the location of the user device 12 and requests the rules 26 associated with the location from the third-party service 28. As discussed above, the location of the user device 12 may be obtained, for example, from an associated GPS receiver, provided by the user of the user device 12, or provided by a device associated with the location. A URL of the third-party service 28 may be known to the user device 12, provided by the user of the user device 12, or provided from a device associated with the location.

In another embodiment, the rules 26 are defined by the user of the user device 12. More specifically, the user of the user device 12 may be identified using, for example, a log-on process. Thereafter, the rules 26 defined by the user may be requested and obtained from the third-party service 28. A URL of the third-party service 28 may be known to the user device 12 or provided by the user of the user device 12.

FIG. 6 illustrates the operation of the system 10 of FIG. 5. In general, the user device 12 first requests the rules 26 from the third-party service 28 (step 300). In response, the third-party service 28 provides the rules 26 to the user device 12 (step 302). The user device 12 then generates a modified profile based on the profile 18 of the user device 12, the rules 26 from the third-party service 28, and optionally the rules 20 defined by the user of the user device 12 (step 304). The user device 12 then provides a request and the modified profile to the destination server 14 via the network 16 (step 306). As discussed above, while the request and the modified profile are illustrated as being provided to the destination server 14 in a single step, the present invention is not limited thereto. The manner in which the modified profile and the request are provided to the destination server 14 may vary depending on the communication protocol used for communication between the user device 12 and the destination server 14.

Upon receiving the request and the modified profile, the destination server 14 operates to customize the response to be provided to the user device 12 (step 308). The response may be customized based on the capabilities of the device, user preferences, demographic information, or any combination thereof identified in the modified profile. Once the customized response is generated, the destination server 14 provides the customized response to the user device 12 (step 310).

FIGS. 7-10 illustrate embodiments of the system 10 of the present invention wherein the profile 18 of the user device 12 is modified by a mediating server 30 rather than the user device 12. More specifically, FIG. 7 illustrates a fourth embodiment of the system 10 wherein the system 10 includes the user device 12, the destination server 14, and the mediating server 30. While only the mediating server 30 is illustrated as being between the user device 12 and the destination server 14, the present invention is not limited thereto. As will be apparent to one of ordinary skill in the art upon reading this disclosure, the mediating server 30 may be part of a distributed network, such as the network 16 (FIG. 1), wherein multiple network nodes may interconnect the mediating server 30 to the user device 12 and the destination server 14. The mediating server 30 may be any network node between the user device 12 and the destination server 14. As an example, the mediating server 30 may be a server associated with a current location of the user device 12 interconnecting the user device 12 to the destination server 14.

In this embodiment, rules 32 are stored by the mediating server 30 and may include rules defined by the user of the user device 12, rules defined by an operator of a current location of the user device 12, or a combination thereof. The rules 32 may be provided to the mediating server 30 from the user device 12

or from an operator, or operator service, associated with the current location of the user device 12. As discussed above, the rules 32 may be defined based on criteria such as, but not limited to, location, time, destination, resource availability, and the like, or any combination thereof.

FIG. 8 illustrates the operation of the system 10 of FIG. 7 according to a fourth embodiment of the present invention. First, a request and the profile 18 of the user device 12 are provided to the mediating server 30 (step 400). While the request and the profile are illustrated as being provided to the mediating server 30 in a single step, the present invention is not limited thereto. The manner in which the profile and the request are provided to the mediating server 30 may vary depending on the communication protocol used for communication between the user device 12 and the mediating server 30.

Using the rules 32, the mediating server 30 processes the profile 18 of the user device 12 to generate a modified profile (step 402). The request and modified profile are then provided to the destination server 14 (step 404). Depending on the communication protocol used, the modified profile may be provided to the destination server 14 with each request from the user device 12 or with only the first request from the user device 12. Upon receiving the request and modified profile, the destination server 14 operates to customize the response to be provided to the user device 12 (step 406). The response may be customized based on the capabilities of the device, user preferences, demographic information, or any combination thereof identified in the modified profile. Once the customized response is generated, the destination server 14 provides the customized response to the mediating server 30 (step 408), which in turn provides the customized response to the user device 12 (step 410).

FIG. 9 illustrates the system 10 according to a fifth embodiment of the present invention. In this embodiment, rules 34 used by the mediating server 30 to modify the profile 18 of the user device 12 are obtained from a third-party service 36 rather than stored by the mediating server 30. The URL of the third-party service 36 is either known to the mediating server 30 or identified in either a request from the user device 12 or the profile 18 of the user device 12. The rules 34 stored by the third-party service 36 may be defined by the user of the user device 12 or an operator of a current location of the user device 12.

FIG. 10 illustrates the operation of the system 10 of FIG. 9 according to a fifth embodiment of the present invention. First, a request and the profile 18 of the user device 12 are provided to the mediating server 30 (step 500). While the request and the profile are illustrated as being provided to the mediating server 30 in a single step, the present invention is not limited thereto. The mediating server 30 then requests the rules 34 from the third-party service 36 (step 502). As stated above, the third-party service 36 may be known to the mediating server 30 or identified in either the request or the profile 18 from the user device 12. In response to the request, the third-party service 36 provides the rules 34 to the mediating server 30 (step 504). Alternatively, if the third-party service 36 is known to the mediating server 30 prior to receiving the request, the mediating server 30 may pre-fetch and cache the rules 34 such that steps 502 and 504 are performed before receiving the request.

Using the rules 34, the mediating server 30 processes the profile 18 of the user device 12 to generate a modified profile (step 506). The request and the modified profile are then provided to the destination server 14 (step 508). Depending on the communication protocol used, the modified profile may be provided to the destination server 14 with each

9

request from the user device **12** or with only the first request from the user device **12**. Upon receiving the request and modified profile, the destination server **14** operates to customize the response to be provided to the user device **12** (step **510**). The response may be customized based on the capabilities of the device, user preferences, demographic information, or any combination thereof identified in the modified profile. Once the customized response is generated, the destination server **14** provides the customized response to the mediating server **30** (step **512**), which in turn provides the customized response to the user device **12** (step **514**).

FIG. **11** is block diagram of an exemplary embodiment of the user device **12** of FIGS. **1-10**. In general, the user device **12** includes a control system **38** having associated memory **40**. The memory **40** stores software instructing the user device **12** to operate according to the present invention. In addition, the memory **40** may store the profile **18** and optionally the rules **20** for modifying the profile **18**. Alternatively, the profile **18** and optionally the rules **20** may be stored in an associated digital storage device such as, but not limited to, a hard-disc drive. The user device **12** also includes a communication interface **42**. The communication interface **42** includes a network interface communicatively coupling the user device **12** to the network **16** and/or the mediating server **30**. In addition, the communication interface **42** may include a secondary interface, which may be a local wireless interface, for communicating with the environment device **24** (FIG. **3**) or other device associated with the current location of the user device **12**. The user device **12** also includes a user interface **44**, which may include components such as, but not limited to, a display, speakers, an input device such as a keyboard or keypad, and the like.

FIG. **12** is a block diagram of an exemplary embodiment of the destination server **14** of FIGS. **1-10**. In general, the destination server **14** includes a control system **46** having associated memory **48**. The memory **48** stores software instructing the destination server **14** to operate according to the present invention. The destination server **14** also includes a communication interface **50** communicatively coupling the destination server **14** to the network **16** or mediating server **30**. The destination server **14** may also include a user interface **52**.

FIG. **13** is a block diagram of an exemplary embodiment of the mediating server **30** of FIGS. **7-10**. In general, the mediating server **30** includes a control system **54** having associated memory **56**. The memory **56** stores software instructing the mediating server **30** to operate according to the present invention. For the embodiment of FIG. **7**, the memory **56** may also store the rules **32**. The mediating server **30** also includes a communication interface **58** communicatively coupling the mediating server **30** to both the user device **12** and the destination server **14**. In addition, for the embodiment of FIG. **9**, the communication interface **58** may further operate to communicatively couple the mediating server **30** to the third-party service **36**. The mediating server **30** may also include a user interface **60**.

Those skilled in the art will recognize improvements and modifications to the preferred embodiments of the present invention. All such improvements and modifications are considered within the scope of the concepts disclosed herein and the claims that follow.

What is claimed is:

1. A method comprising:

automatically modifying, at a mediating server interconnecting a user device and a destination server, a device capability identified in a device profile that identifies a

10

plurality of device capabilities of the user device based on at least one rule in response to a request for content; providing the modified device profile to the destination server; and

receiving a customized response from the destination server in response to the request for content from the user device, wherein the destination server provides the customized response based on the modified device profile.

2. The method of claim **1** wherein the at least one rule is based, at least in part, on time.

3. The method of claim **1** wherein the at least one rule defines a period of time and the device capability of the user device to be disabled for the period of time, and modifying, at the mediating server interconnecting the user device and the destination server, the device capability identified in the device profile comprises modifying, at the mediating server interconnecting the user device and the destination server the device profile to remove the device capability from the device profile during the period of time.

4. The method of claim **1** wherein the at least one rule defines a period of time and the device capability of the user device to be enabled for the period of time, and modifying, at the mediating server interconnecting the user device and the destination server, the device capability identified in the device profile comprises modifying, at the mediating server interconnecting the user device and the destination server the device profile to add the device capability to the device profile during the period of time.

5. The method of claim **1** wherein the at least one rule is based, at least in part, on location.

6. The method of claim **1** wherein the at least one rule defines a location and the device capability of the user device to be disabled when the user device is present at the location, and modifying, at the mediating server interconnecting the user device and the destination server, the device capability identified in the device profile comprises modifying, at the mediating server interconnecting the user device and the destination server, the device profile to remove the device capability from the device profile when the user device is present at the location.

7. The method of claim **1** wherein the at least one rule defines a location and the device capability of the user device to be enabled when the user device is present at the location, and modifying, at the mediating server interconnecting the user device and the destination server, the device capability identified in the device profile comprises modifying, at the mediating server interconnecting the user device and the destination server, the device profile to add the device capability to the device profile when the user device is present at the location.

8. The method of claim **1** wherein the at least one rule is based, at least in part, on time and location.

9. The method of claim **1** wherein the at least one rule defines a location, a period of time, and the device capability of the user device to be disabled for the period of time when the user device is present at the location, and modifying, at the mediating server interconnecting the user device and the destination server, the device capability identified in the device profile comprises modifying, at the mediating server interconnecting the user device and the destination server, the device profile to remove the device capability from the device profile for the period of time when the user device is present at the location.

10. The method of claim **1** wherein the at least one rule defines a location, a period of time, and the device capability of the user device to be enabled for the period of time when

11

the user device is present at the location, and modifying, at the mediating server interconnecting the user device and the destination server, the device capability identified in the device profile comprises modifying, at the mediating server interconnecting the user device and the destination server, the device profile to add the device capability to the device profile for the period of time when the user device is present at the location.

11. The method of claim 1 wherein the at least one rule is based, at least in part, on the destination server.

12. The method of claim 1 wherein the at least one rule identifies the destination server and the device capability of the user device to be disabled when requesting content from the destination server, and modifying, at the mediating server interconnecting the user device and the destination server, the device capability identified in the device profile comprises modifying, at the mediating server interconnecting the user device and the destination server, the device profile to remove the device capability from the device profile when providing the device profile to the destination server.

13. The method of claim 1 further comprising modifying the device profile of the user device to remove information from the device profile based on at least one additional rule.

14. The method of claim 13 wherein the information comprises at least a portion of at least one of a group consisting of: user preferences and demographic information.

15. The method of claim 13 wherein the at least one rule is associated with the destination server such that the information is removed from the device profile when providing the device profile to the destination server.

16. The method of claim 1 wherein the at least one rule is based, at least in part, on resource availability.

17. The method of claim 1 wherein the at least one rule is defined by a user of the user device.

18. The method of claim 1 wherein the at least one rule is defined by an operator associated with a current location of the user device.

19. The method of claim 1 further comprising storing the at least one rule locally.

20. The method of claim 1 further comprising obtaining the at least one rule from an environment device associated with a current location of the user device.

21. The method of claim 1 further comprising obtaining the at least one rule from a third-party service.

22. The method of claim 1 wherein the device profile is a Composite Capability/Preference Profile (CC/PP).

23. A method comprising:
automatically modifying, at a mediating server interconnecting a user device and a destination server, a device profile of the user device to remove information from the device profile based on at least one rule in response to a

12

request for content, wherein the device profile identifies a plurality of device capabilities;
providing the modified device profile to the destination server; and

receiving a customized response from the destination server in response to the request for content from the user device, wherein the destination server provides the customized response based on the modified device profile.

24. A mediating server comprising:

a communication interface communicatively coupling the mediating server to a user device and a destination server; and

a control system associated with the communication interface and adapted to:

receive a device profile that identifies a plurality of device capabilities of the user device from the user device;

modify a device capability identified in the device profile of the user device based on at least one rule;

provide the modified device profile to the destination server;

request content from the destination server in response to a request for the content from the user device;

receive a customized response from the destination server in response to the request, wherein the destination server provides the customized response based on the modified device profile; and

provide the customized response to the user device.

25. A mediating server comprising:

a communication interface communicatively coupling the mediating server to a user device and a destination server; and

a control system associated with the communication interface and adapted to:

receive a device profile that identifies a plurality of device capabilities of the user device from the user device;

modify the device profile of the user device to remove information from the device profile based on at least one rule;

provide the modified device profile to the destination server;

request content from the destination server in response to a request for the content from the user device;

receive a customized response from the destination server in response to the request, wherein the destination server provides the customized response based on the modified device profile; and

provide the customized response to the user device.

* * * * *