

US008165422B2

(12) **United States Patent**  
**Wilson**

(10) **Patent No.:** **US 8,165,422 B2**  
(45) **Date of Patent:** **\*Apr. 24, 2012**

(54) **METHOD AND SYSTEM FOR REDUCING EFFECTS OF UNDESIRE SIGNALS IN AN INFRARED IMAGING SYSTEM**

(75) Inventor: **Andrew D. Wilson**, Seattle, WA (US)

(73) Assignee: **Microsoft Corporation**, Redmond, WA (US)

(\* ) Notice: Subject to any disclaimer, the term of this patent is extended or adjusted under 35 U.S.C. 154(b) by 212 days.

This patent is subject to a terminal disclaimer.

(21) Appl. No.: **12/492,178**

(22) Filed: **Jun. 26, 2009**

(65) **Prior Publication Data**

US 2009/0262070 A1 Oct. 22, 2009

**Related U.S. Application Data**

(60) Continuation of application No. 12/106,910, filed on Apr. 21, 2008, now Pat. No. 7,613,358, which is a division of application No. 10/870,777, filed on Jun. 16, 2004, now Pat. No. 7,593,593.

(51) **Int. Cl.**  
**G06K 9/40** (2006.01)  
**G06F 3/045** (2006.01)

(52) **U.S. Cl.** ..... **382/275; 345/174**

(58) **Field of Classification Search** ..... **382/260, 382/274, 275, 284, 291; 345/174**  
See application file for complete search history.

(56) **References Cited**

**U.S. PATENT DOCUMENTS**

4,896,029 A 1/1990 Chandler  
4,992,650 A 2/1991 Somerville

5,109,537 A 4/1992 Toki  
5,153,418 A 10/1992 Batterman  
5,291,564 A 3/1994 Shah  
5,319,214 A 6/1994 Gregory  
5,436,639 A 7/1995 Arai  
5,483,261 A 1/1996 Yasutake  
5,526,177 A 6/1996 Fantone  
5,528,263 A 6/1996 Platzker

(Continued)

**FOREIGN PATENT DOCUMENTS**

EP 0690407 5/2004

(Continued)

**OTHER PUBLICATIONS**

Office Action dated Nov. 23, 2009 cited in U.S. Appl. No. 11/218,171.

(Continued)

*Primary Examiner* — John Strege

(74) *Attorney, Agent, or Firm* — Workman Nydegger

(57) **ABSTRACT**

Effects of undesired infrared light are reduced in an imaging system using an infrared light source. The desired infrared light source is activated and a first set of imaging data is captured during a first image capture interval. The desired infrared light source is then deactivated, and a second set of image data is captured during a second image capture interval. A composite set of image data is then generated by subtracting from first values in the first set of image data corresponding second values in the second set of image data. The composite set of image data thus includes a set of imaging where data all infrared signals are collected, including both signals resulting from the IR source and other IR signals, from which is subtracted imaging in which no signals result from the IR course, leaving image data including signals resulting only from the IR source.

**8 Claims, 6 Drawing Sheets**

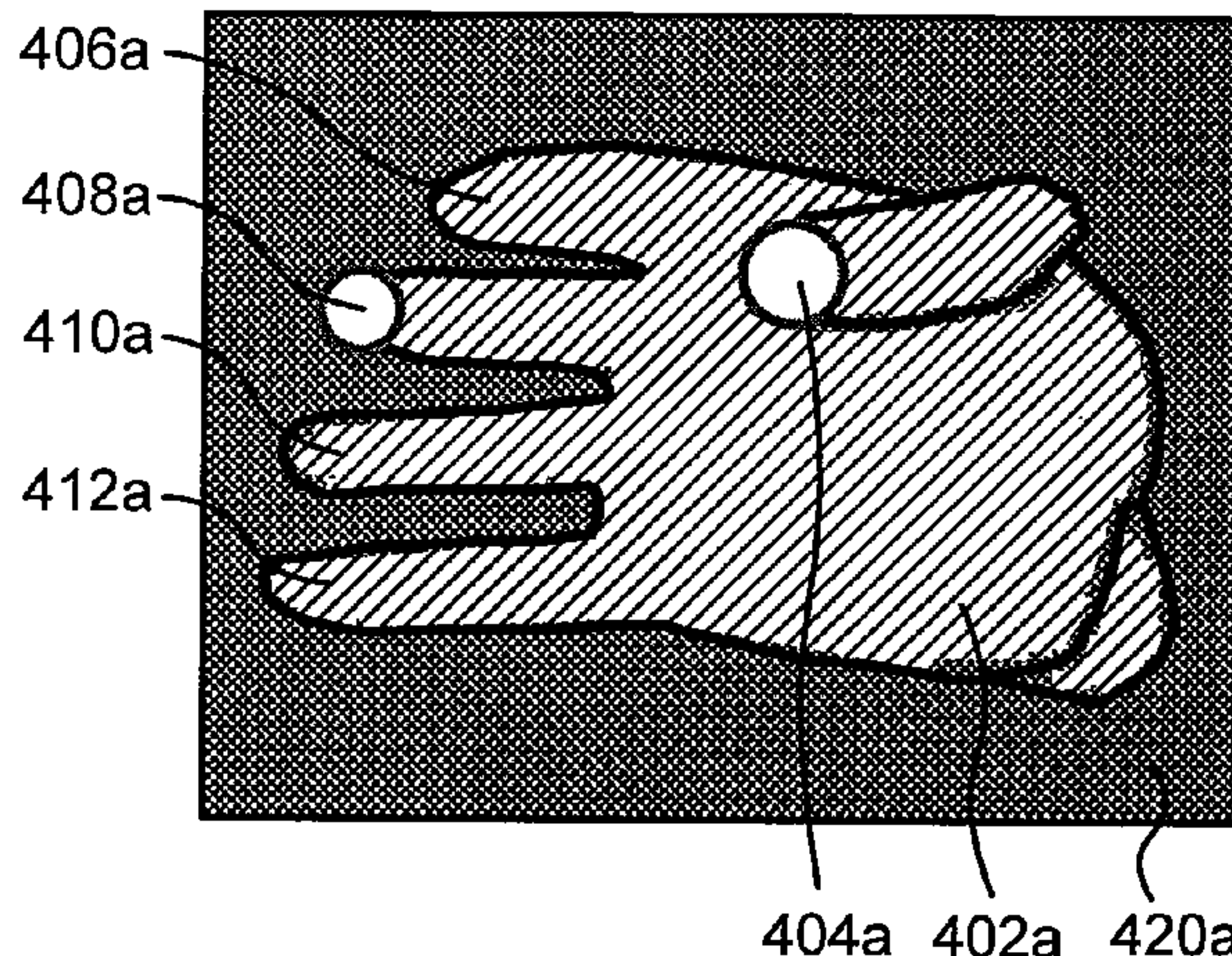
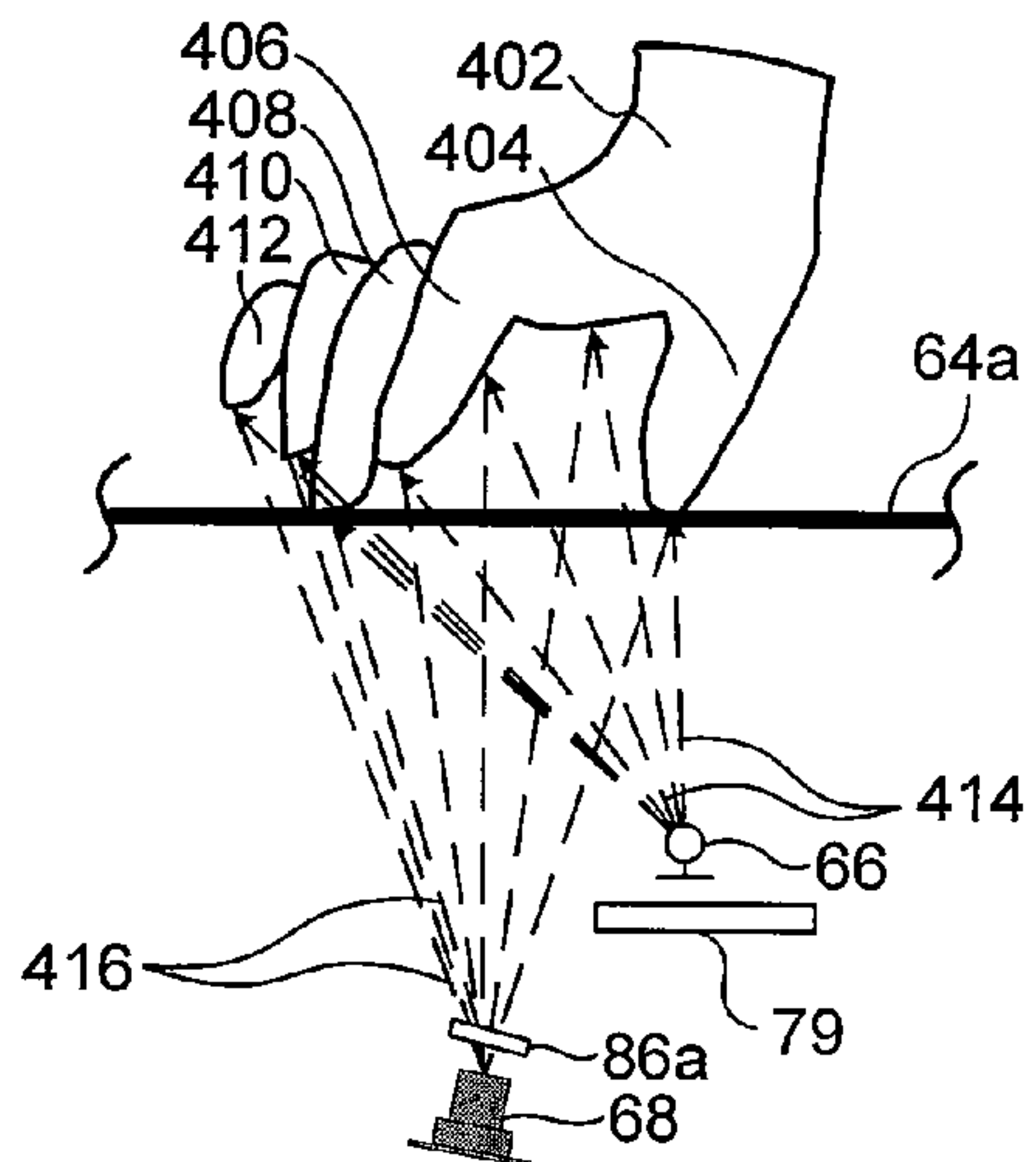



U.S. PATENT DOCUMENTS

5,821,930	A	10/1998	Hansen	
5,831,601	A	11/1998	Vogeley	
5,835,692	A	11/1998	Cragun	
5,900,863	A	5/1999	Numazaki	
5,920,688	A	7/1999	Cooper	
5,940,076	A	8/1999	Sommers	
5,973,315	A	10/1999	Saldana	
5,973,689	A	10/1999	Gallery	
6,067,369	A	5/2000	Kamei	
6,088,019	A	7/2000	Rosenberg	
6,094,509	A	7/2000	Zheng	
6,111,565	A	8/2000	Chery	
6,128,003	A	10/2000	Smith	
6,154,214	A	11/2000	Uyehara	
6,181,343	B1	1/2001	Lyons	
6,195,104	B1	2/2001	Lyons	
6,243,492	B1	6/2001	Kamei	
6,266,061	B1	7/2001	Doi	
6,269,172	B1	7/2001	Rehg et al.	
6,340,119	B2	1/2002	He	
6,400,836	B2	6/2002	Senior	
6,414,672	B2	7/2002	Rekimoto	
6,448,987	B1	9/2002	Easty	
6,469,722	B1	10/2002	Kinoe	
6,476,378	B2	11/2002	Nougaret	
6,478,432	B1	11/2002	Dyner	
6,520,648	B2	2/2003	Stark	
6,522,395	B1	2/2003	Barnji	
6,529,183	B1	3/2003	MacLean	
6,545,663	B1	4/2003	Arbter	
6,600,475	B2	7/2003	Gutta et al.	
6,604,682	B2	8/2003	Wakamiya	
6,614,422	B1	9/2003	Raffi	
6,636,621	B2	10/2003	Thebaud	
6,654,007	B2	11/2003	Ito	
6,663,244	B1	12/2003	Wichner	
6,690,363	B2	2/2004	Newton	
6,710,770	B2	3/2004	Tomasi	
6,714,221	B1	3/2004	Christie	
6,720,949	B1	4/2004	Pryor	
6,750,877	B2	6/2004	Rosenberg	
6,781,069	B2	8/2004	Silverstein	
6,788,813	B2	9/2004	Cooper	
6,791,530	B2	9/2004	Vernier	
6,804,396	B2	10/2004	Higaki et al.	
6,812,907	B1	11/2004	Gennetten	
6,840,627	B2	1/2005	Olbdrich	
6,888,960	B2	5/2005	Penev et al.	
6,895,104	B2	5/2005	Wendt	
6,959,102	B2 *	10/2005	Peck ..... 382/103	
7,007,236	B2	2/2006	Dempski et al.	
7,075,687	B2	7/2006	Lippert	
7,084,859	B1	8/2006	Pryor	
7,095,401	B2	8/2006	Liu et al.	
7,120,280	B2	10/2006	Biswas	
7,144,117	B2	12/2006	Kojima	
7,161,578	B1	1/2007	Schneider	
7,168,813	B2	1/2007	Wong	
7,204,428	B2	4/2007	Wilson	
7,268,774	B2	9/2007	Pittel	
7,310,085	B2	12/2007	Holloway	
7,327,376	B2	2/2008	Shen	
7,372,977	B2	5/2008	Fujimura et al.	
7,397,464	B1	7/2008	Robbins	
7,404,146	B2	7/2008	Bennetts	
7,418,671	B2	8/2008	Hama	
7,467,380	B2	12/2008	Kurlander	
2001/0012001	A1 *	8/2001	Rekimoto et al. .... 345/173	
2001/0036299	A1	11/2001	Senior	
2002/0006786	A1	1/2002	Mine	
2002/0041700	A1	4/2002	Thebaud	
2003/0156756	A1	8/2003	Gokturk et al.	
2003/0161524	A1	8/2003	King	
2004/0001113	A1	1/2004	Zipperer et al.	
2004/0005920	A1	1/2004	Soltys	
2004/0090524	A1	5/2004	Belliveau	
2004/0155902	A1	8/2004	Dempski et al.	
2004/0196371	A1	10/2004	Kono	

2005/0050476	A1	3/2005	SanGiovanni
2005/0064936	A1	3/2005	Pryor
2005/0122306	A1	6/2005	Bell
2005/0122308	A1	6/2005	Bell
2005/0151850	A1	7/2005	Ahn et al.
2005/0212753	A1	9/2005	Marvit et al.
2005/0226467	A1	10/2005	Hatano
2005/0226505	A1	10/2005	Wilson
2005/0227217	A1	10/2005	Wilson
2005/0238201	A1	10/2005	Shamaie
2005/0245302	A1	11/2005	Bathiche
2005/0255434	A1	11/2005	Lok et al.
2005/0277071	A1	12/2005	Yee
2006/0010400	A1	1/2006	Dehlin
2006/0034492	A1	2/2006	Siegel
2006/0056662	A1	3/2006	Thieme
2006/0092170	A1	5/2006	Bathiche
2006/0092267	A1	5/2006	Dempski et al.
2006/0178212	A1	8/2006	Penzias
2006/0244719	A1	11/2006	Brigham
2007/0046625	A1	3/2007	Dawson
2007/0063981	A1	3/2007	Galyean
2007/0126717	A1	6/2007	Cohen
2007/0157095	A1	7/2007	Bilow
2007/0279494	A1	12/2007	Aman
2008/0122786	A1	5/2008	Pryor et al.
2008/0231611	A1	9/2008	Bathiche

FOREIGN PATENT DOCUMENTS

FR	27656077	8/2003
JP	2004-259247	9/2004
JP	2004319364	11/2004
JP	2006031941	2/2006
JP	2007514242	5/2007
WO	WO 91/18383	11/1991
WO	9714075	4/1997
WO	98/19292	5/1998
WO	WO 01/84251	11/2001
WO	0557399	6/2005

OTHER PUBLICATIONS

Office Action dated Jan. 4, 2009 cited in U.S. Appl. No. 10/867,434.

Strickson, Joshua and Paradiso, Joseph; "Tracking Hands Above Large Interactive Surfaces with Low-Cost Scanning D Laser Rangefinder" ACM CHI. 98 Conference, Apr. 21-23, 1998, Los Angeles, CA.; pp. 1-2.

Lensch, Hendrick P.A; Goesele, Michael; Jan Kautz; Hans-Peter Seidel; "A Framework for the Acquisition, processing, Transmission, and Interactive Display of High Quality 3D Models on the Web" Research Report, Max-0 Planck-Institute, May 2001; Sections 5 and 8.

Notice of Allowance dated Oct. 8, 2008 cited in U.S. Appl. No. 10/880,167.

Notice of Allowance Dated Oct. 17, 2008 cited in U.S. Appl. No. 10/969,746.

Office Action dated Oct. 7, 2008 cited in U.S. Appl. No. 11/218,171.

Office Action dated Oct. 30, 2008 cited in U.S. Appl. No. 12/106,910.

Wilson, et al., "U.S. Appl. No. 11/225,726", "Pointing device and cursor for use in intelligent computing environments", Sep. 13, 2005.

Wilson, et al., "U.S. Appl. No. 11/463,183", "Virtual Controller for Visual Displays", Aug. 8, 2006.

Wilson, et al., "U.S. Appl. No. 10/396,653", "Architecture for controlling a computer using hand gestures", Mar. 25, 2003.

Wilson, Andrew D., "U.S. Appl. No. 10/914,922", "Surface UI for gesture-based interaction", Aug. 10, 2004.

Wilson, Andrew D., "U.S. Appl. No. 12/106,910", "Method and System for Reducing Effects of Undesired Signals in an Infrared Imaging System", Apr. 21, 2008.

Wilson, et al., "U.S. Appl. No. 11/939,739", "Magic Wand", Nov. 14, 2007.

U.S. Appl. No. 10/867,434, filed Jun. 14, 2010, Notice of Allowance.

U.S. Appl. No. 11/218,171, filed Jun. 17, 2010, Office Action.

U.S. Appl. No. 10/813,855, filed Jun. 22, 2010, Office Action.

U.S. Appl. No. 12/110,032, filed Jul. 8, 2010, Office Action.

U.S. Appl. No. 11/321,551, filed Jul. 9, 2010, Office Action.



- U.S. Appl. No. 12/110,032, filed Nov. 2, 2010, Notice of Allowance.
- "3.6 Interpolation in Two or More Dimensions," Numerical Recipes in C: The Art of Scientific Computing. Chapter 3. Interpolation and Extrapolation. © 1988-1992, Cambridge University Press. Numerical Recipes Software. pp. 123-128.
- "Bar Code 1, 2-Dimensional Bar Code Page" Available <http://www.adams1.com/pub/russadam/stack.html>. Printed Jan. 20, 2004. 14pp.
- Ambiente article. "InteracTable®." Dated Jul. 2007 2k. Available <http://www.darmstadt.gmd.de/ambiente/activities/interactable.html>. Printed Nov. 21, 2003 3pp.
- Bier, Stone, Pier, Buston, and DeRose. "Toolglass and Magic Lenses: The See-Through Interface." Proceedings of Siggraph '93 (Anaheim, August). Computer Graphics Annual Conference Series, ACM, 1993, pp. 73-80. 8pp.
- Blickenstorfer, Conrad H. "First Look: Acer TravelMate TM100 with Windows XP Tablet PC Edition." Pen Computing Magazine. Jul. 2002. pp. 47-47.
- "DiamondSpin—Begs for Direct Manipulation Technology Is it in the Pen? Sony Leaps Out-of-the-Box Again Pen with Gummi." Mitsubishi/DiamondSpin. CHI 2004#3. Printed Apr. 30, 2004. 5pp.
- Dietz and Leigh, "DiamondTouch: A Multi-User Touch Technology." UIST '01 Orlando FLA. © ACM 2001 1-58113-438-x/01/11. CHI Letters 3 (2). Nov. 11-14, 2001. pp. 219-226.
- Electronic Check Alliance Processing, Inc. "Gift Cards, How Stored Value Card Systems Work." Available. <http://www.electron-cap.com/GiftCards.htm>. Printed Jan. 20, 2004 and May 16, 2004. ©2003. 2pp. Total (3pp printed).
- Fukuchi and Rekimoto. Interaction Techniques for SmartSkin.: ACM UIST2002 demonstration, 2002. 2pp.
- Grabowski, Robert. "A Miniature Video Laser Range Finder for Small Robots." Available [http://www.andrew.cmu.edu/~rig/research\\_hardware/laser\\_rangefinder.html](http://www.andrew.cmu.edu/~rig/research_hardware/laser_rangefinder.html). Printed May 16, 2004. 8pp.
- Grant and Winograd. "Flexible, Collaborative Organization on a Tabletop." ACM CSCW 2002: Workshop on Co-located Tabletop Collaboration: Technologies and Directions. New Orleans, LA. Nov. 2002. pp. 1-4.
- Horn, Berthold K.P. "Robot Vision." The MIT Press. Available <http://mitpress.mit.edu/catalog/item/default.asp?tttype=2&tid=8388>. Printed Dec. 17, 2003. 6pp. Total.
- Horn, Berthold Klaus Paul. "Robot Vision." Binary Images: Topological Properties. The MIT Electrical Engineering and Computer Science Series. 1986. pp. 66-71 an cover pages(s).
- Hunter, Andrew. "Connected Components Analysis (Computer Vision)." www.google.com search results <http://www.google.com/search?sourceid=navclient&q=connected+component+ellipse>. Printed Mar. 7, 2004. Article dated Sep. 24, 2002. 2pp search results, 21pp article.
- IR Distance Sensor.: Available <http://www.diyelectronics.com/Accessories/IRDS.html> (2pp) and <http://www.diyelectronics.com/Accessories/GP2D05.html> (1pg.). Printed Dec. 30, 2003. 3pp.
- "Tangible Bits: Towards Seamless Interfaces between People, Bits and Atoms." Proceedings of CHI '97, Mar. 22-27, 1997, Atlanta, Georgia © 1997 ACM 0-89791-802-9/97/03. pp. 1-8.
- Ishii, Wisneski, Orbanes, Chun, and Paradiso. "PinPongPlus: Design of an Athletic-Tangible Interface for Computer-Supported Cooperative Play." Proceedings of CHI '99, May 15-20, 1999, © 1999 ACM. pp. 1-8.
- Johanson, Kolodny, and Russell. "A Hand Pose and Position Tracker for the Interactive Table." CS223B Final Project. Available <http://graphics.stanford.edu/~drussel/vision/tracker-report.html>. Printed Dec. 16, 2003, 6pp.
- Ju, Hurwitz, Judd, and Lee. "CounterActive: An Interactive Cookbook for the Kitchen Counter." Extended Abstracts of CHI 2001, Seattle. Apr. 2001 pp. 269-270.
- Kang, Sing Bing. "Radial Distortion Snakes." IAPR Workshop on Machine Vision Applications (MVA2000), Tokyo, Japan. Nov. 2000. pp. 603-606.
- Klemmer, Newman, and Sapien. "The Designer's Outpost: A Task-Centered Tangible Interface for Web Site Information Design." Proceedings of Human Factors in Computing Systems: CHI 2000 Extended Abstracts. The Hague, The Netherlands. Apr. 1-6, 2000. pp. 333-334.
- Klemmer, Newman, Farrell, Bilezikjian, and Landay. "The Designers' Outpost: A Tangible Interface for Collaborative Web Site Design." CHI Letters, The 14th Annual ACM Symposium on User Interface Soft Technology: UIST 2001. 3(2). pp. 1-10.
- Kobayashi, Hirano, Narita, and Ishi. "A Tangible Interface for IP Network Simulation." CHI 2003, Apr. 5-10, 2003, F. Lauderdale, FL ACM 1-58113-630-7/03/0004. 2pp.
- Koike, Sato, and Kobayashi. "Integrating Paper and Digital Information on EnhanceDesk: A Method for Realtime Finger Tracking on an Augmented Desk System." ACM Transaction on Computer-Human Interaction, vol. 8 No. 4, Dec. 2001. ©2001 ACM 1073-0516/01/1200-0307. pp. 307-322.
- Leibe, Starner, Ribarsky, Wartell, Krum, Singletary, and Hodges. "The Perceptive workbench: Toward Spontaneous and Natural Interaction in Semi-Immersive Virtual Environments." Proceedings of the IEEE Virtual Reality 2000 Conference, Mar. 18-22, 2000. New Brunswick, New Jersey: IEEE Computer Society, 2000. 8pp.
- Leigh and Dietz "DiamondTouch Characteristics and Capabilities." Mitsubishi Electric Research Laboratories, Cambridge, Massachusetts, USA. Undated. 2pp. Magerkurth, Stenzel, and Prante. "STARS—A Ubiquitous Computing Platform for Computer Augmented Tabletop Games." 5th International Conference on Ubiquitous Computing (UbiComp '03), Oct. 12-15, 2003, Seattle, Washington. 2 pp.
- Malandain, Gregoire. "Connected Components Extraction." Available <http://www.sop.inria.fr/epidaure/personnel/malandai/segment/connese.html>. Printed Dec. 18, 2003. 3pp.
- Matsushita and Rekimoto. "HoloWall; Designing a Finger, Hand, Body, and Object Sensitive Wall." UIST '97 Banff, Alberta, Canada. © 1997 ACM 0-89791-881-9/97/10. pp. 209-210.
- Missouri Department of Revenue. "2D Barcode Technology." Undated. 3pp.
- Moran, Saund, van Melle, Gujar, Fishkin, and Harrison. "Design and Technology for Collaborative; Collaborative Collages of Information on Physical Walls." UIST '99. Asheville, NC. © 1999 ACM 1-58113-075-9/99/11, CHI Letters vol. 1, 1. pp. 197-206.
- Pangaro, Maynes-Aminzade, and Ishii. "The Actuated Workbench: Computer-Controlled Actuation in Tabletop Tangible Interfaces." Proceedings of UIST 2002, Oct. 27-30, 2002. © 2002 ACM. 10pp.
- Paradiso, Hsiao, Strickon, Lifton, and Adler. "Sensor systems for interactive surfaces." IBM Systems Journal, vol. 39, Nos. 3&4, 2000. pp. 892-914.
- Patten, Ishii, Hines, and Pangaro. "Sensetable: A Wireless Object Tracking Platform for Tangible User Interfaces." Proceedings of CHI 2001, Mar. 31-Apr. 5, 2001, ACM Press, © 2001 ACM. 8pp.
- Patten, Recht, and Ishii. "Audiopad: A Tag-based Interface for Musical Performance." Proceedings of Conference on New Interface for Musical Expression (NIME '02). Dublin, Ireland, May 24-26, 2002 6pp.
- Ramos and Balakrishnan. "Fluid Interaction Techniques for the Control and Annotation of Digital Video." UIST '03 Vancouver, B.C., Canada. © 2003 ACM 1-58133-636-06/03/0010. pp. 105-114.
- Rekimoto and Ayatsuka "CyberCode: Designing Augmented Reality Environments with Visual Tags." Proc. of UIST 2000, 2000. 10pp.
- Rekimoto and Matsushita. "Perceptual Surfaces: Towards a Human and Object Sensitive Interactive Display." Proceedings of Workshop on Perceptual User Interacts (PUI'97), 1997. 3pp.
- Rekimoto and Nagao. "The World through the Computer: Computer Augmented Interaction with Real World Environments." Proceedings of UIST'95, 1995. pp. 29-36.
- Rekimoto and Saitoh. "Augmented Surfaces: A Spatially Continuous Work Space for Hybrid Computing Environments." CHI '99, May 15-20, 1999. Pittsburgh, Pennsylvania. © ACM 1999 0-201-48559-1/99/05. pp. 378-385.
- Rekimoto, Jun. "Matrix: A Realtime Object Identification and Registration Method for Augmented Reality." Proc. of Asia Pacific Computer Human Interaction (APCHI '98), 1998. 6pp.
- Rekimoto, Jun. "Multiple-Computer User Interfaces: 'Beyond the Desktop' Direct Manipulation Environments." ACI CHI2000 Video Proceedings, 2000. 2pp.
- Rekimoto, Jun. "Pick-and-Drop: A Direct Manipulation Technique for Multiple Computer Environments." Proceedings of UIST'97, 1997. pp. 31-39.



- Rekimoto, Jun. "SmartSkin: An Infrastructure for Freehand Manipulation on Interactive Surfaces." CHI 2002, Apr. 20-25, 2002, Minneapolis, Minnesota. © 2001 ACM 1-58113-453-3/02/0004. 8pp.
- Rekimoto, Ullmer, and Oba. "Data Tiles: A Modular Platform for Mixed Physical and Graphical Interactions." SIGCHI'01, Mar. 31-Apr. 4, 2001, Seattle, WA. © 2001 ACM 1-58113-327-8/01/0003. 8pp.
- Reznik, Canny, and Alldrin. "Leaving on a Plane Jet." 2001 Int. Conf. on Intell. Robots & Systems (IROS), Maui, Hawaii, Oct. 2001. 6pp.
- Ringel, Gerh, Jin, and Winograd. "Barehands: Implement-Free Interaction with a Wall-Mounted Display." Short Talk. CHI Mar. 31-Apr. 5, 2001. pp. 367-368.
- Rosenfeld, Zawadzki, Sudol, and Perlin. "Planar Manipulator Display." New York University mrl. NYU Media Research Lab. Available <http://cat.nyu.edu/PMD>. Printed May 16, 2004. 3pp.
- Rovani, David (Posted by). "My Second Month with the Compaq Tablet.". Home>Reviews, TablePCHome.com—Table PC user community. Posted Apr. 10, 2003. Available <http://www.tabletpchome.com/Messages.aspx?ThreadID=140>. Printed Dec. 30, 2003. pp. 1-2 of 5.
- Schmalstieg, Encarnação, and Szalavári. "Using Transparent Props for Interaction With The Virtual Table." Presented at 1999 ACM Symposium on Interactive 3D Graphics (I3DG '99). Apr. 26-28, 1999, Atlanta, GA. 7pp.
- Scott, Grant, and Mandryk. "System Guidelines for Co-located collaborative Work on a Tabletop Display." Proceedings of ECSCW'03, European Conference Computer-Supported Cooperative Work 2003, Helsinki, Finland, Sep. 14-18, 2003. 20pp.
- Shen, Everitt, and Ryall. "UbiTable: Impromptu Face-to-Face Collaboration on Horizontal Interactive Surfaces." © Mitsubishi Electric Research Laboratories, Inc., 2003. Cambridge, Massachusetts. TR-2003-49. Sep. 2003. 10pp.
- Shen, Lesh, and Vernier. "Personal Digital Historian: Story Sharing Around the Table" Interactions. Mar. + Apr. 2003. pp. 15-22.
- Shen, Lesh, Bernier, Forlines, and Frost. "Sharing and Building Digital Group Histories." CSCW'02, Nov. 16-20, 2002, New Orleans, Louisiana. © 2002 ACM 1-58113-560-2/02/0011. 10pp.
- Shen, Lesh, and Moghaddam, Beardsley, and Bardsley. "Personal Digital Historian: User Interface Design." © Mitsubishi Electric Research Laboratories, Inc. 2001. Cambridge, Massachusetts. 5pp.
- Shen, Vernier, Forline, and Ringel. "DiamondSpin: An Extensible Toolkit for Around-the-Table Interaction." CHI 2004, Apr. 24-29, 2004, Vienna, Austria. © 2004 ACM 1-58113-702-8/04/0004. 8pp.
- Smart Technologies Inc. White Paper. "DViT Digital Vision Touch Technology." Feb. 2003. 10pp.
- Smart Technologies, Inc. "Rear Projection SMART Board™ Interactive Whiteboard" "SMART Board Software". Available <http://www.smarttech.com/Products/rearprojection/index.asp> and <http://www.smarttech.com/Products/sbsoftware/index.asp>. Printed Dec. 16, 2003. 5pp. total.
- Starner, Leibe, Singletary, Lyons, Gandy, and Pair. "Towards Augmented Reality Gaming." Available <http://www.gvu.gatech.edu/ccg/publications/imagina2000/>. Printed Dec. 30, 2003. 27pp.
- Streitz, Geißler, Holmer, Konomi, Müller-Tomfelde, Reischl, Rexrogh, Seitz, and Steinmetz. "i-LAND: An interactive Landscape for Creativity and Innovation." Proceedings of the ACM Conference on Human Factors in Computing Systems (CHI'99), Pittsburgh, Pennsylvania, May 15-20, 1999. ACM Press, New York. pp. 120-127.
- Symanzik, Jürgen. "Three-Dimensional Statistical Graphics Based on Interactively Animated Anaglyphs." Published 1993. Available <http://citeseer.nj.nec.com/95667.html>. Printed Feb. 25, 2004. 7pp. total.
- "The Tablet PC A detailed look at Microsoft's proposed Tablet PC." Pen Computing Magazine: Tablet PC. Available [http://www.pencomputing.com/frames/textblock\\_tablet\\_pc.html](http://www.pencomputing.com/frames/textblock_tablet_pc.html). Printed Dec. 30, 2003. pp. 1.
- Tandler, Prante, Müller-Tomfelde, Streitz, and Steinmetz. "ConnectTables: Dynamic Coupling of Displays for the Flexible Creation of Shared Workspaces." Proceedings of the 14. Annual ACM Symposium on User Interface Software and Technoic (USIT'01), ACM Press (CHI Letters 3(2)), 2001, pp. 11-20.
- Ullmer and Ishii. "The metaDESK: Models and Prototypes for Tangible User Interfaces." Proceedings of UIST'97, Oct. 14-17, 1997. © 1997 ACM—ACM 0-89791-881-9/97/10. 10pp.
- Ullmer, Ishii and Glas. "mediaBlocks: Physical Containers, Transports, and Controls for Online Media." Computer Graphics Proceedings (SIGGRAPH'98), Jul. 19-24, 1998, © 1998 ACM. ACM-0-89791-999-88/98/007. 8pp.
- Ullmer, Ishii and Jacob. "Tangible query Interfaces: Physically Constrained Tokens for Manipulating Database Queries." Proc. INTERACT 2003 Conference, 2003. 11pp.
- Underkoffler and Ishii. "Illuminating Light: An Optical Design Tool with a Luminous-Tangible Interface." Proceeding of CHI '98, Apr. 18-23, 1998, © 1998 ACM. pp. 1-8.
- Underkoffler and Ishii. "Urp: A Luminous-Tangible Workbench for Urban Planning and Design." Proceedings of CHI '99. May 15-20, 1999. © 1998 ACM. pp. 1-8.
- Underkoffler Ullmer, and Ishii. "Emancipated Pixels: Real-World Graphics in the Luminous Room." Proceedings of SIGGRAPH '99, Aug. 8-13, 1999, © 1999 ACM. 8pp.
- Vernier, Lesh and Shen. "Visualization Techniques for Circular Tabletop Interfaces." To appear in Advanced Visual Interfaces, May 2002, Trento, Italy. © 2002 Mitsubishi Electric Research Laboratories, Inc. MERL-TR2002-01. Authored Mar. 2002. 10pp.
- Viola and Jones. "Robust Real-time Object Detection." Cambridge Research Laboratory, Technical Report Series. Compaq. CRL 2001/01, Feb. 2001. 30pp.
- "Virtualboard." Available <http://visilab.unime.it/visilab/virtualboard.htm>. Printed Dec. 16, 2003. 6pp.
- Von Hardenberg and Bérard. Bare-Hand Human-Computer Interaction. PUI 2001 Orlando, FL, ©2001 ACM 1-58113-448-7-11/14/01. 8pp.
- Wellner, Pierre. "Interacting with Paper on the DigitalDesk." Communications of the ACM. Jul. 1993. EuroPARC tech report EPC-93-195. 17pp.
- Whalen, Tara. "Playing Well with Others: Applying Board Game Design to Tabletop Display Interfaces." UIST 2003. Vancouver, Nov. 2-5, 2003, 3pp.
- Wu and Balakrishnan. "Multi-Finger and Whole Hand Gestural Interaction Techniques for Multi-User Tabletop Displays." UIST '03, Vancouver, B.C., Canada. © 2003 ACM 1-58113-636-6/03/0010. pp. 193-202.
- Hardenberg Von. Christian, "Fingertracking and Handposture Recognition for Real-Time Human-Computer Interaction", Berlin, Jul. 20, 2001.
- Kijma, Ryugo, et al. "Distributed Display Approach Using PHMD with Infrared Camera", Proceedings of the IEEE Virtual Reality, Orlando, Florida, Mar. 24-28, 2002. pp. 1-8.
- Pavlidis, Ioannis, et al. "A Vehicle Occupant Counting System Based on Near-Infrared Phenomenology and Fuzzy Neural Classification", IEEE Transactions on Intelligent Transportation System, New York, NY, vol. 1, No. 2., Jun. 2000, pp. 78-80.
- "The Tracking Cube: A Three Dimensional Input Device" IBM Technical Disclosure Bulletin, IBM Corp. New York, US, vol. 32, No. 3B; Aug. 1, 1989, pp. 91-95.
- Northrop Grumman "TouchTable™" Brochure ©2005 Northrop Grumman Space & Mission Systems Corp. RS1190705. 2 pages.
- Department of Defense, Department of Defense Logistics Automatic Identification Technology Handbook for Product and Shipping Label Quality Assurance, Feb. 15, 2000, p. 14, Section 3.3.3.6, <http://www.dodait.com/conf/data1199/printquality/print0111r6.doc>.
- Kato Billinghamurst, Poupyrev, Imamoto, and Tachibana. "Virtual Object Manipulation on a Table-Top AR Environment." IEEE and ACM Int'l Symposium on Augmented Reality 2000, ISAR '2000, Oct. 5-6, 2000, Munich, 9 pages.
- Office Action dated Mar. 25, 2008 cited in U.S. Appl. No. 10/880,167.
- Notice of Allowance dated Dec. 31, 2008 cited in U.S. Appl. No. 10/880,167.
- Office Action mailed Jun. 29, 2007 cited in U.S. Appl. No. 10/834,675.
- Office Action dated Dec. 13, 2007 cited in U.S. Appl. No. 10/834,675.



Notice of Allowance dated Mar. 28, 2008 cited in U.S. Appl. No. 10/834,675.  
Notice of Allowance dated Oct. 16, 2007 cited in U.S. Appl. No. 10/814,761.  
Notice of Allowance mailed Feb. 27, 2008 cited in U.S. Appl. No. 10/814,761.  
Office Action dated Aug. 30, 2007 cited in U.S. Appl. No. 10/870,777.  
Notice of Allowance dated Feb. 28, 2008, cited in U.S. Appl. No. 10/870,777.  
Office Action dated Aug. 29, 2008 cited in U.S. Appl. No. 10/870,777.  
Notice of Allowance dated May 6, 2009 cited in U.S. Appl. No. 10/870,777.  
Office Action dated Oct. 9, 2007 cited in U.S. Appl. No. 10/867,434.  
Office Action dated Jul. 10, 2008 cited in U.S. Appl. No. 10/867,434.  
Office Action dated Nov. 28, 2008 cited in U.S. Appl. No. 10/867,434.  
Office Action dated Sep. 17, 2009 cited in U.S. Appl. No. 10/867,434.  
Notice of Allowance dated Apr. 23, 2008 cited in U.S. Appl. No. 10/969,746.  
Notice of Allowance dated Mar. 11, 2009 cited in U.S. Appl. No. 10/969,746.  
Office Action dated Jun. 12, 2008 cited in U.S. Appl. No. 11/117,979.  
Notice of Allowance dated Sep. 11, 2008 cited in U.S. Appl. No. 11/117,979.  
Notice of Allowance dated Nov. 14, 2008 cited in U.S. Appl. No. 11/117,979.  
Office Action dated Oct. 9, 2007 cited in U.S. Appl. No. 10/813,855.  
Office Action dated May 7, 2008 cited in U.S. Appl. No. 10/813,855.

Office Action dated Feb. 19, 2009 cited in U.S. Appl. No. 10/813,855.  
Office Action dated Sep. 24, 2009 cited in U.S. Appl. No. 10/813,855.  
Notice of Allowance dated Jun. 26, 2009 cited in U.S. Appl. No. 12/106,910.  
Office Action dated Jun. 26, 2008 cited in U.S. Appl. No. 11/364,319.  
Notice of Allowance dated Dec. 31, 2008 cited in U.S. Appl. No. 11/364,319.  
Office Action dated Sep. 2, 2008 cited in U.S. Appl. No. 11/170,234.  
Notice of Allowance dated Jan. 12, 2009 cited in U.S. Appl. No. 11/170,234.  
Office Action dated Feb. 8, 2008 cited in U.S. Appl. No. 11/321,551.  
Office Action dated Aug. 19, 2008 cited in U.S. Appl. No. 11/321,551.  
Office Action dated Jan. 26, 2009 cited in U.S. Appl. No. 11/321,551.  
Office Action dated Aug. 4, 2009 cited in U.S. Appl. No. 11/321,551.  
Office Action dated Apr. 15, 2009 cited in U.S. Appl. No. 11/218,171.  
Office Action dated Oct. 26, 2009 cited in U.S. Appl. No. 11/321,551.  
U.S. Appl. No. 11/218,171, mail date Dec. 13, 2010, Notice of Allowance.  
Office Action dated Mar. 31, 2010 cited in U.S. Appl. No. 11/321,551.  
U.S. Appl. No. 13/032,877, filed Feb. 23, 2011, Yee.  
U.S. Appl. No. 11/321,551, mail date Mar. 17, 2011, Notice of Allowance.  
Office Action dated Nov. 9, 2011 cited in U.S. Appl. No. 10/813,855.  
U.S. Appl. No. 10/813,855, mail date May 6, 2011, Office Action.  
U.S. Appl. No. 13/250,101, filed Sep. 30, 2011, Billow.  
U.S. Appl. No. 11/321,551, mail date Jul. 11, 2011, Notice of Allowance.

\* cited by examiner

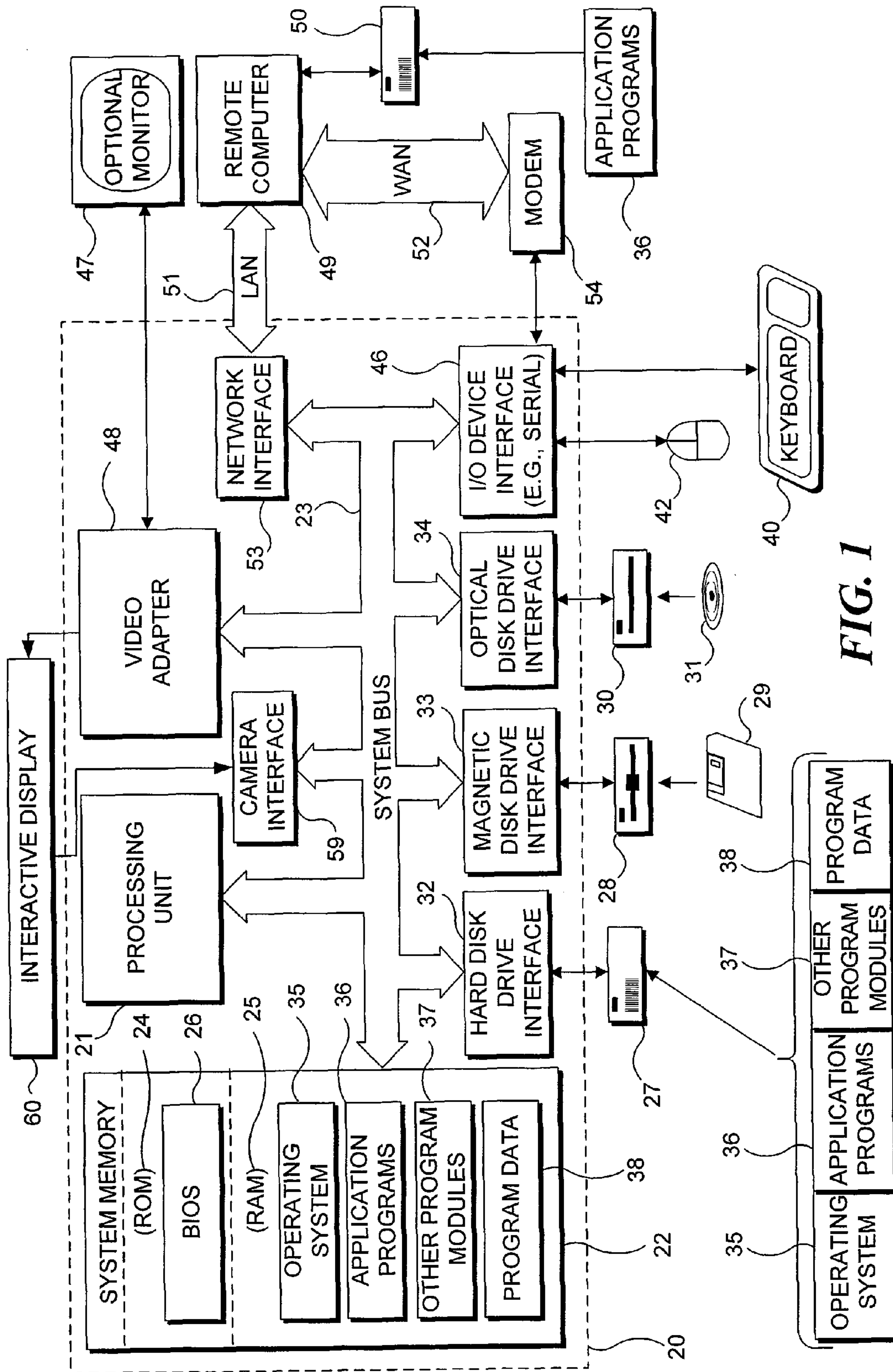

FIG. 1

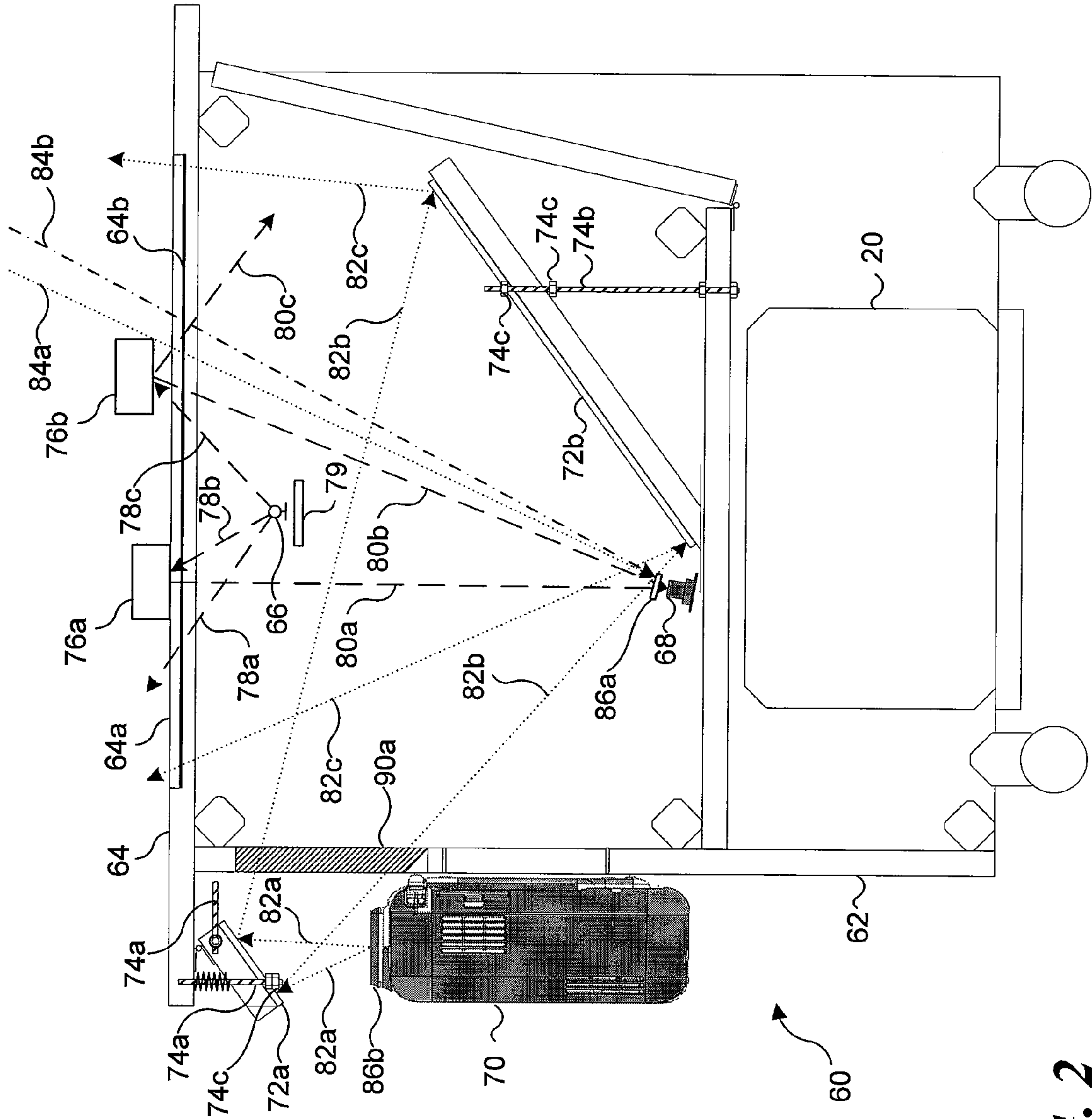
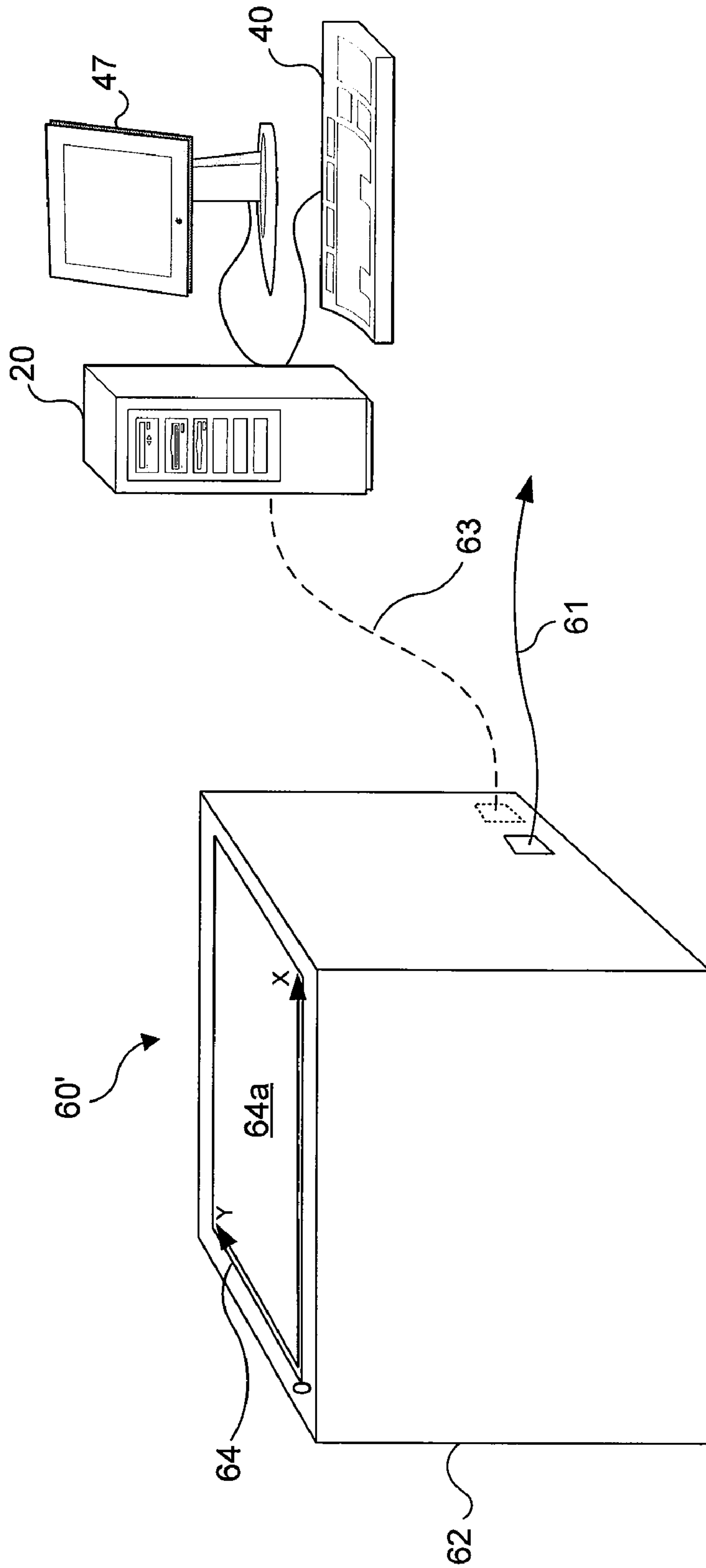
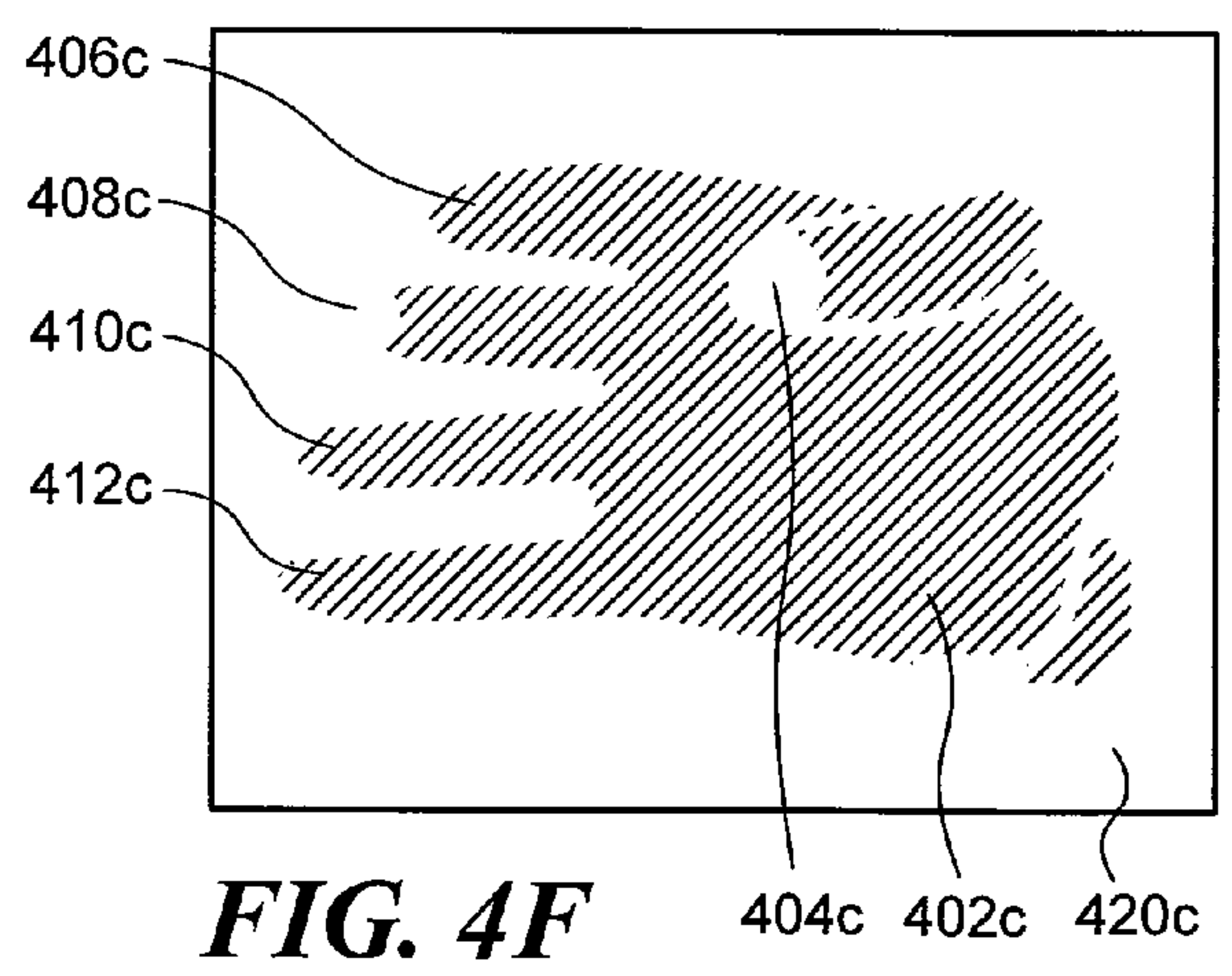
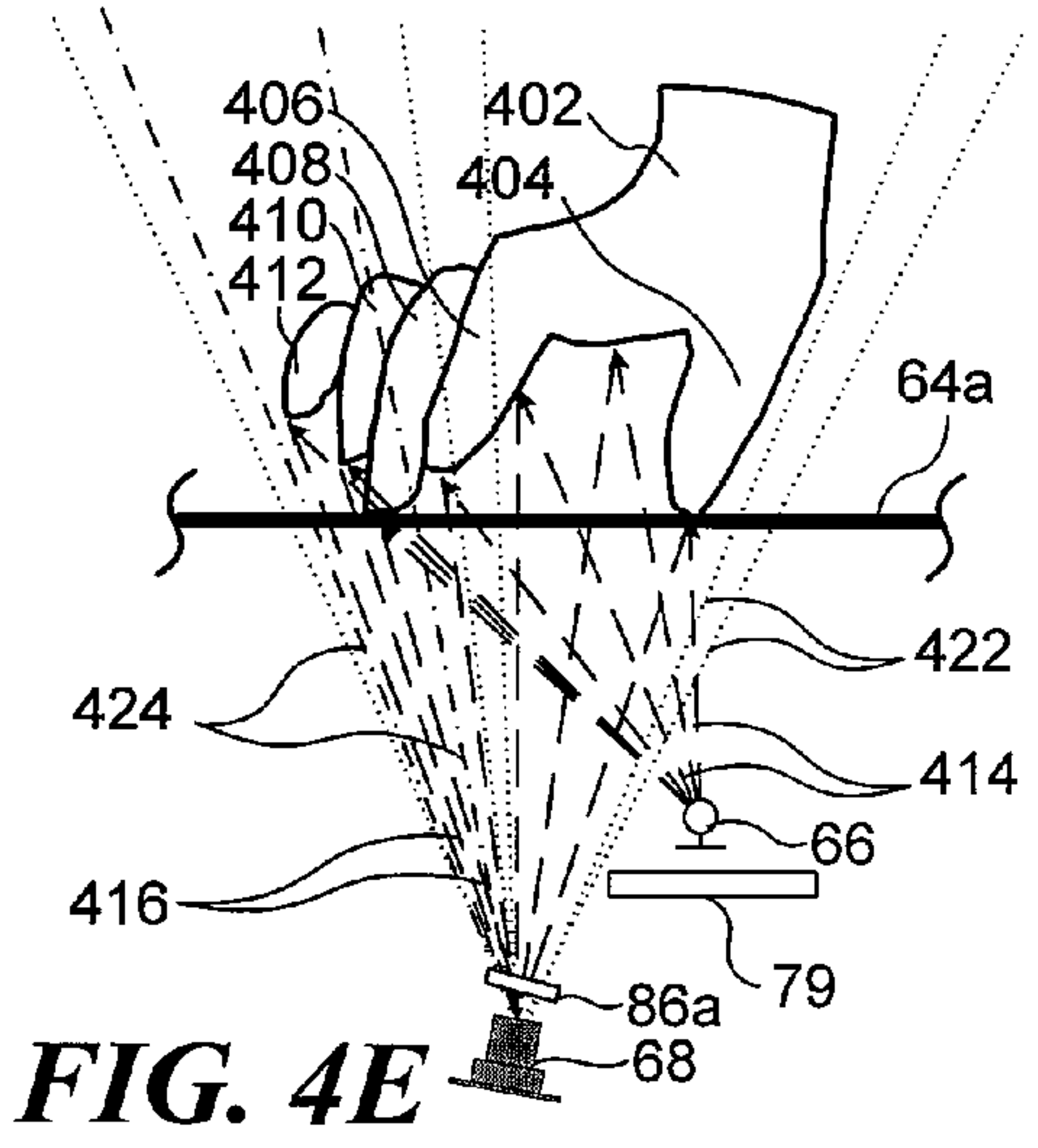
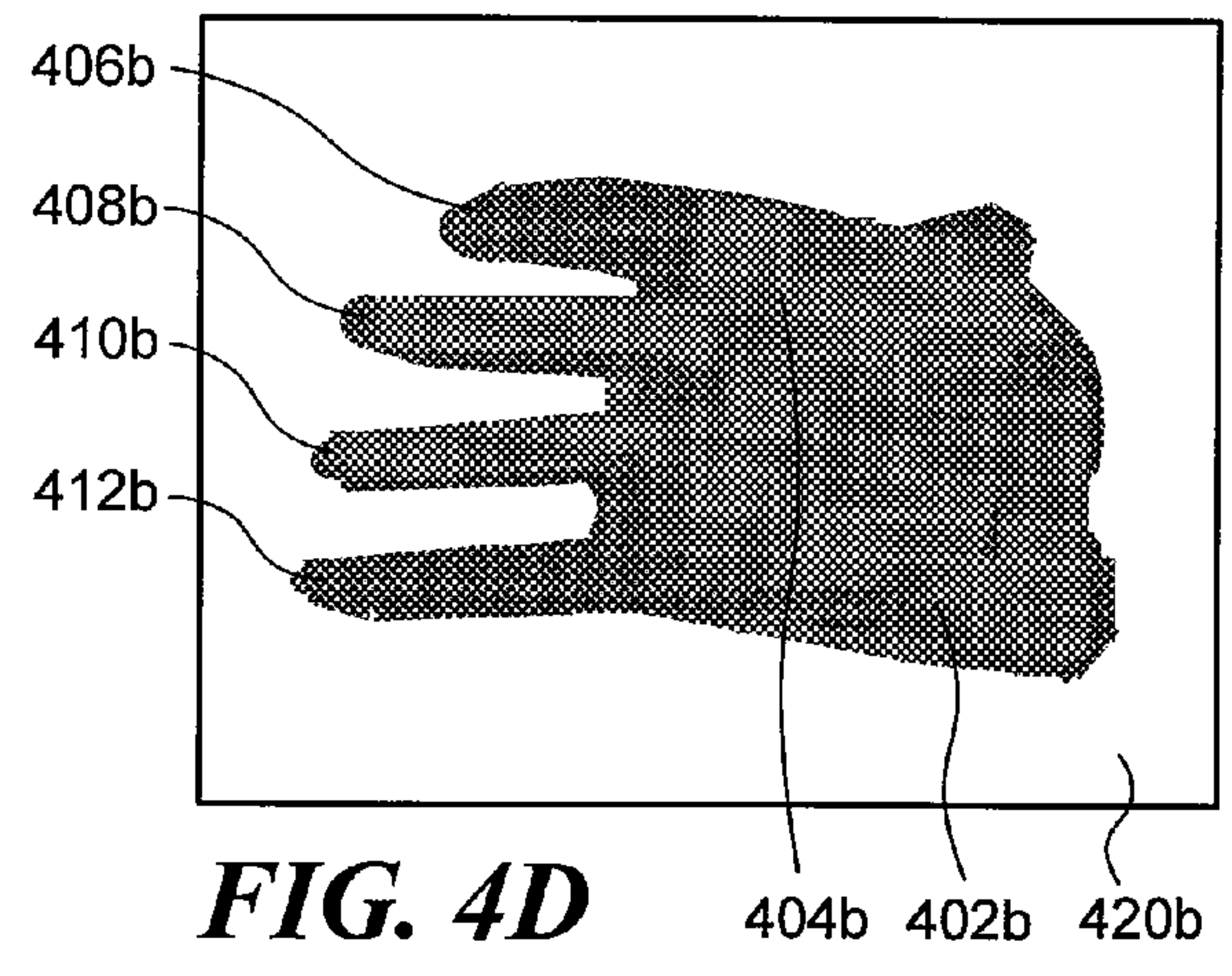
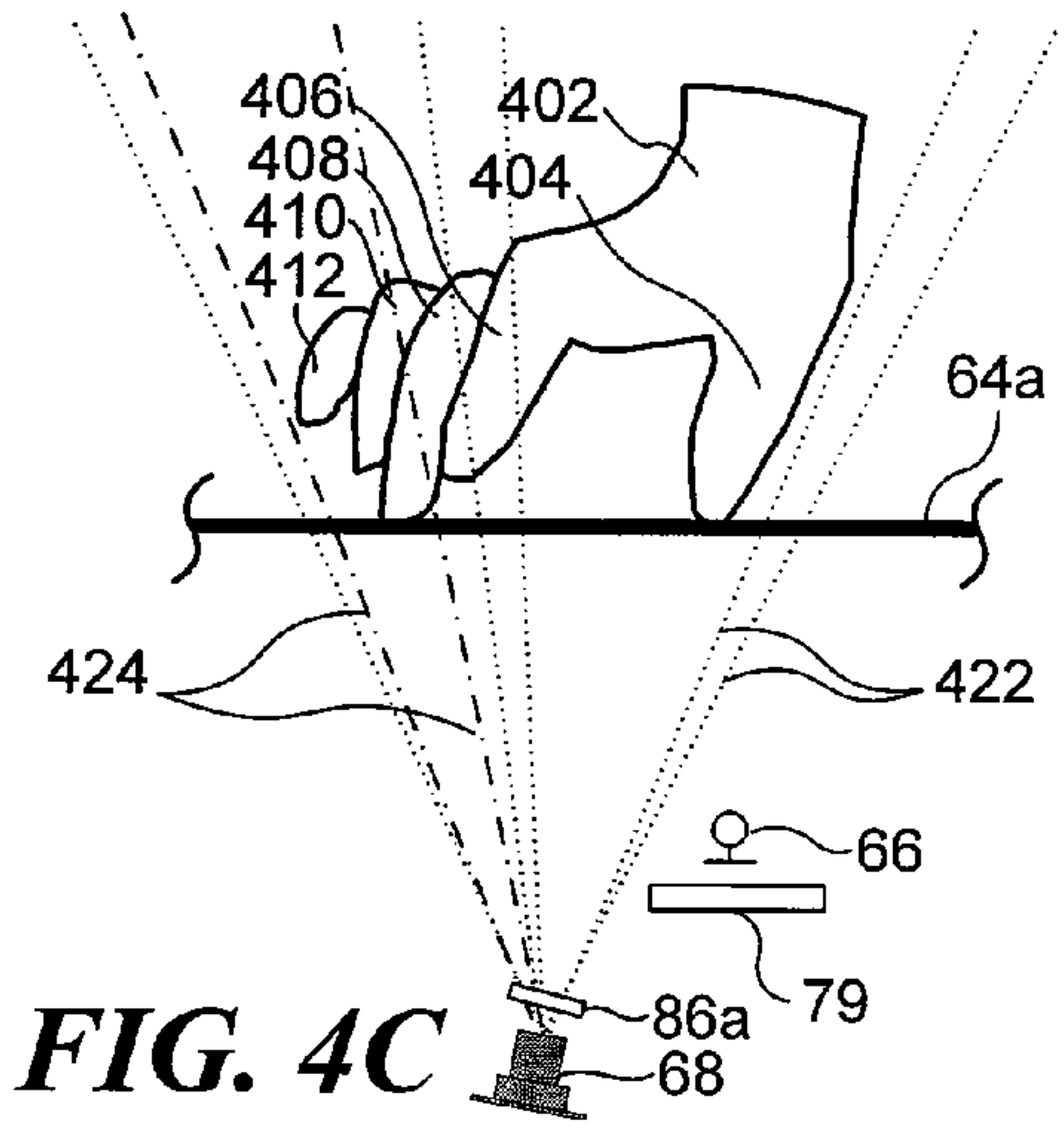
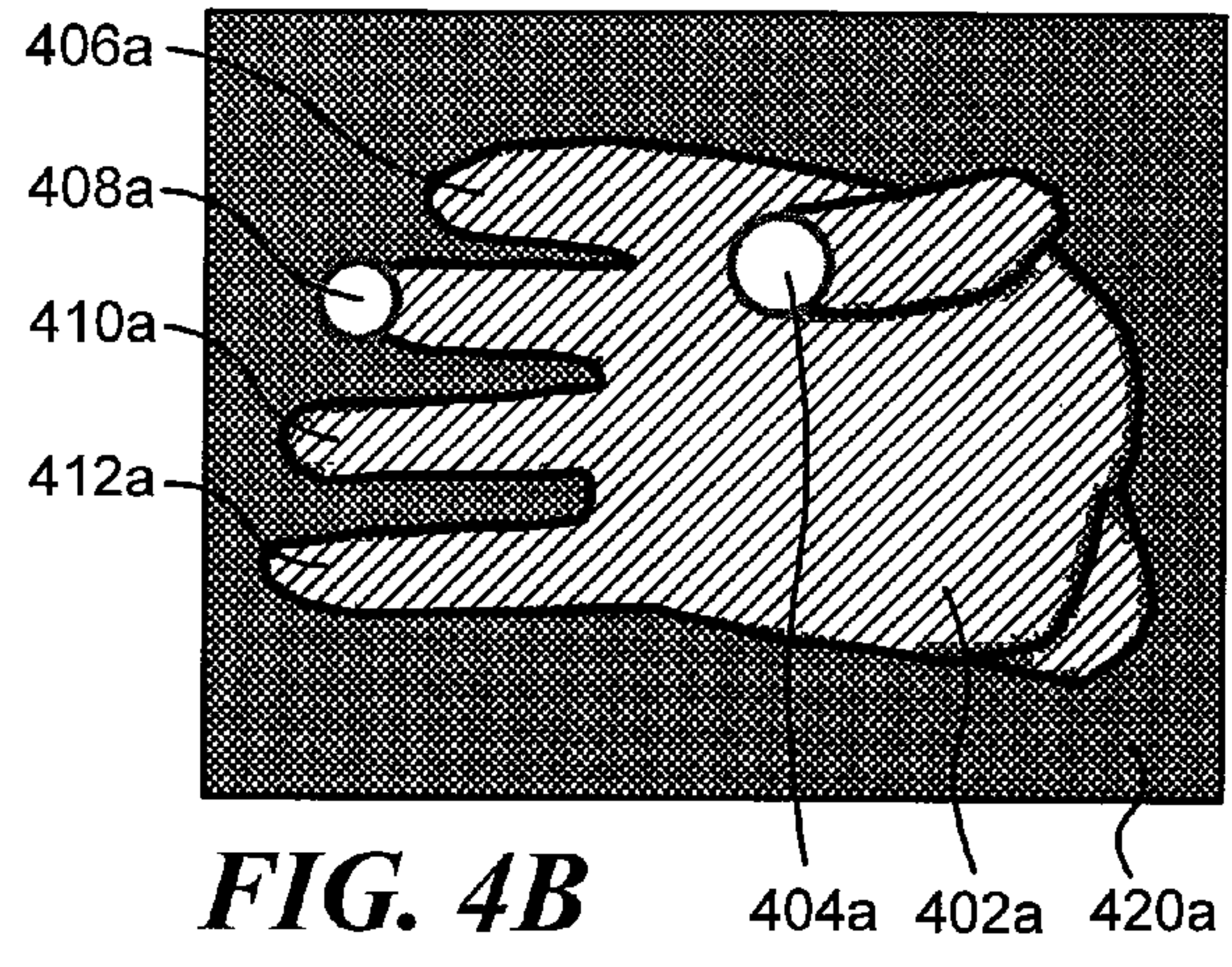
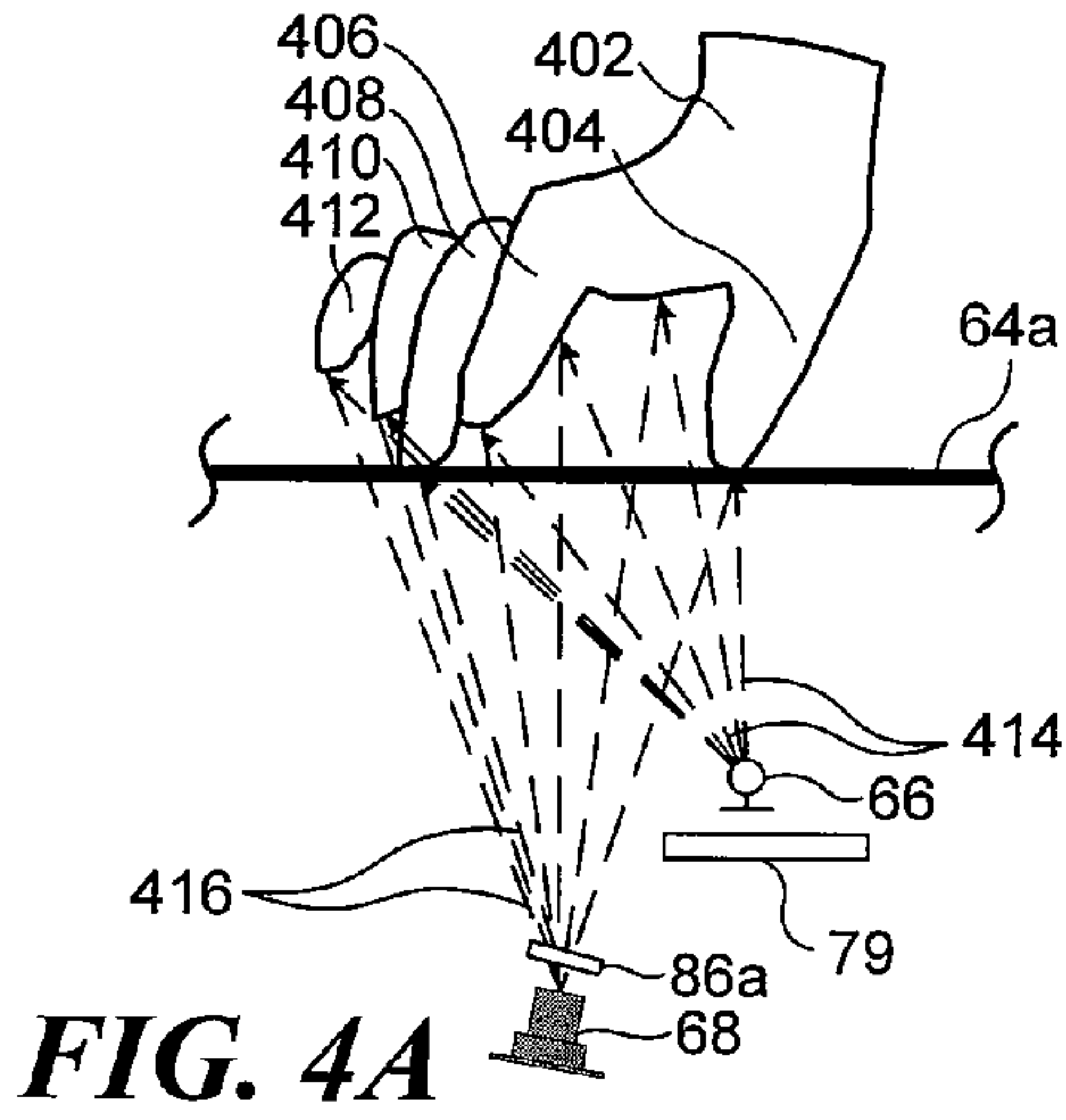

FIG. 2



**FIG. 3**





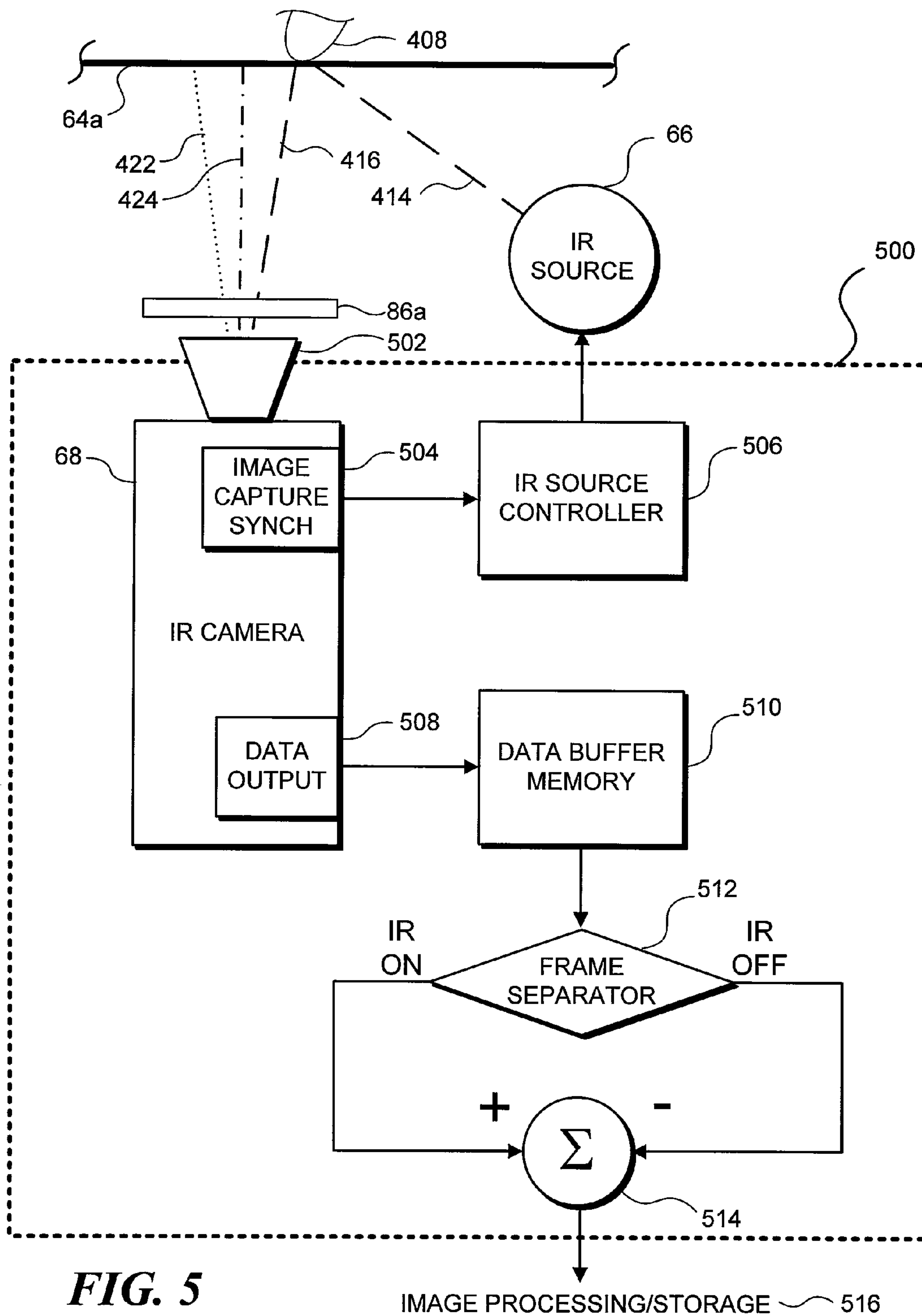

FIG. 5

IMAGE PROCESSING/STORAGE 516



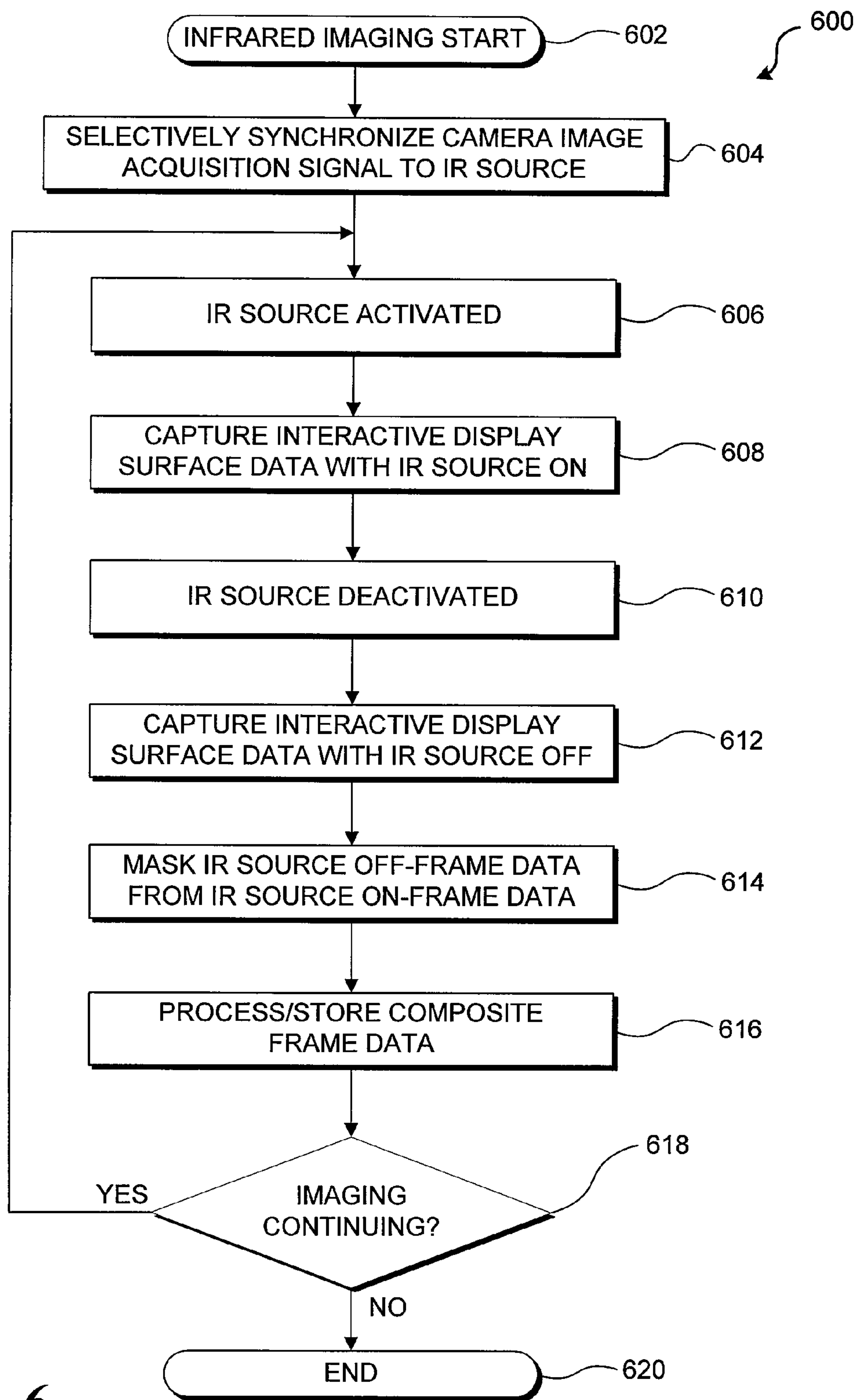

FIG. 6

1

## METHOD AND SYSTEM FOR REDUCING EFFECTS OF UNDESIRE SIGNALS IN AN INFRARED IMAGING SYSTEM

### CROSS-REFERENCE TO RELATED APPLICATIONS

This application claims priority to, the benefit of, and is a continuation of co-pending U.S. patent application Ser. No. 12/106,910, filed on Apr. 21, 2008, entitled "METHOD AND SYSTEM FOR REDUCING EFFECTS OF UNDESIRE SIGNALS IN AN INFRARED IMAGING SYSTEM", which claims priority to, the benefit of, and is a divisional application of co-pending U.S. patent application Ser. No. 10/870,777, filed Jun. 16, 2004, entitled "Methods and System for Reducing Effects of Undesired Signals in an Infrared Imaging System", the entire contents of both of which are hereby incorporated by reference.

### FIELD OF THE INVENTION

The present invention generally pertains to active infrared (IR) imaging, and more specifically, to removing IR signals received from unintended and undesired IR sources in a region of interest to improve the quality of imaging data resulting from the active IR source.

### BACKGROUND OF THE INVENTION

The presence of undesired signals is a concern in the processing of virtually all electromagnetic signals. Even in a relatively simple system, such as a radio, a squelch control is often provided to attenuate signals below a certain magnitude, so as to avoid undesired background static being audible when a signal of interest is not being received. What constitutes undesired background static is for the user to judge, and the user can set the squelch control to limit the audibility of received signals based on the user's judgment.

Automated signal processing systems, where a computer system autonomously responds to input signals, present a more difficult problem. Unlike the example of a squelch control noted above, where a user can adjust the squelch level based on experience and judgment, it is more difficult to program a computer system to automatically set a limit to differentiate between types of signals that are desirable and those that are not. For example, computers respond well to unambiguous input from keyboards, pointing devices, and similar input devices, but respond less satisfactorily to voice commands. Anyone who has used speech recognition programs has experienced some difficulty when the computer fails to recognize something the user said, which happens more often if there is any background noise or other sounds that affect the auditory input perceived by the computer.

Computer vision arguably is a much more intricate problem than speech recognition. If the computer must process too many visual signals or too broad a range of visual signals, the input will more likely be misread by the computer. On the other hand, if the computer suppresses too many visual signals, the computer also may misread visual inputs or ignore intended visual inputs entirely.

Today, computer vision is becoming an increasingly important field in furthering the desire to make computers and their interfaces even more user friendly. For example, the MIT Media Lab, as reported by Brygg Ullmer and Hiroshi Ishii in "The metaDESK: Models and Prototypes for Tangible User Interfaces," *Proceedings of UIST October 1997*: 14-17," has developed another form of "keyboardless" human-ma-

2

chine interface. The metaDESK includes a generally planar graphical surface that not only displays computing system text and graphic output, but also receives user input by "seeing" and responding to an object placed against the graphical surface. The combined object responsive and display capability of the graphical surface of the metaDESK is facilitated using IR lamps, an IR camera, a video camera, a video projector, and mirrors disposed beneath the surface of the metaDESK. The mirrors reflect the graphical image projected by the projector onto the underside of the graphical display surface to provide images that are visible to a user from above the graphical display surface. The IR camera can detect IR reflections from the undersurface of an object placed on the graphical surface. By "seeing" and detecting a specially formed object or IR-reflected light from an object disposed on a graphical display surface, the metaDESK can respond to the contemporaneous placement and movement of the object on the display surface to carryout a predefined function, such as displaying and moving a map of the MIT campus.

Others have been developing similar keyboardless interfaces. For example, papers published by Jun Rekimoto of the Sony Computer Science Laboratory, Inc., and associates describe a "HoloWall" and a "HoloTable" that display images on a surface and use IR light to detect objects positioned adjacent to the surface.

Both the metaDESK and HoloWall/HoloTable use IR light to see objects and movements for good reasons. If the systems responded to visible light, visible light projected by the systems and reflected back by the interactive surface could lead to false readings by the computing system. Further, even if reflections could be suppressed, unless the system is disposed in a dark room, room lights and other visible light passing through the interactive display surface would substantially adversely affect the computer vision systems.

Using reflected IR light to detect objects placed on an interactive display surface avoids much of the problems that would arise from attempting to recognize the objects with ubiquitous visible light. However, although people are generally aware of the IR content of light produced by most sources, because it is not visible to the naked eye, ambient IR light signals that might adversely impact computer vision systems also are very common. Incandescent lights, the sun, and a variety of other common sources generate IR light. These unintended IR signals, just like unintended visible light signals, can provide undesired input to IR-sensitive computer vision systems. Band-pass type filters can suppress visible light and other non-IR light, but they are not helpful in separating IR light reflected from an object that is to be detected from background IR light.

It is therefore desirable to filter, mask, or otherwise reduce the effects of unintended and undesired IR light signals, to prevent IR light vision systems from responding to extraneous IR light signals. The effect of the undesirable background IR light should be avoided when detecting objects without requiring that an IR computer vision system be operated in an environment that shields it from all background IR sources.

### SUMMARY OF THE INVENTION

One of the more important functions of the present invention is to reduce the effects of undesired IR sources, including ambient sources such as sunlight, incandescent light, and other IR sources, in an IR imaging system. Imaging data are captured both when the IR source controlled by the IR imaging system is activated and when it is not. The imaging data collected when the controlled IR source is deactivated are imaging data based on undesired IR sources. Thus, by pixel-



wise subtracting a set of imaging data collected when the IR source was deactivated, from a set of imaging data collected when the IR source was activated, the resulting composite set of imaging data should include only imaging data resulting from illumination generated by the controlled IR source.

One aspect of the present invention is thus directed to a method for reducing effects of undesired IR light sources in an imaging system using an IR light source. The IR light source is activated during a first image capture interval, and a first set of imaging data is captured during the first image capture interval. The IR light source is then deactivated, and a second set of image data is captured during the second image capture interval. A composite set of image data is then generated by subtracting from first values in the first set of image data corresponding second values in the second set of image data.

In accordance with one embodiment of the present invention, activation of the IR light source is controlled by an image capture device, such that an image capture signal generated by the image capture device causes the IR light source to be activated during the first image capture interval and deactivated during the second image capture interval.

The IR light source is disposed on a first side of a light-permeable surface. As a result, the IR light source directs IR light on a physical object disposed adjacent an opposite side of the light-permeable surface. The image capture device, like the IR source, is disposed on the first side of a light-permeable surface and is used to capture IR light cast by the IR light source that has been reflected by the physical object.

The image processing system uses the light reflected by the physical object in the composite set of image data to recognize a characteristic of the physical object. In this method, the first values in the first set of image data represent an intensity of IR light captured for each of a plurality of points across the first side of the light-permeable surface during the first image capture interval, while the IR light source was activated. The second values in the set of image data represent an intensity of IR light captured for each of the plurality of points across the first side of the light-permeable surface during the second image capture interval, while the IR light source was deactivated.

In one embodiment of the present invention, the composite image data are determined by the equation:

$$D(x,y)=I_{ON}(x,y)-I_{OFF}(x,y)$$

where:

x,y represents a coordinate location of a point on the first side of the light permeable surface;

$I_{ON}(x,y)$  represents intensity of IR light detected during the first image capture interval at point x,y;

$I_{OFF}(x,y)$  represents intensity of IR light detected during the second image capture interval at point x,y; and.

$D(x,y)$  represents the net intensity of IR light at point x,y when the intensity of the IR light captured at the point x,y during the second image capture interval is subtracted from the intensity of the IR light captured at the point x,y during the first image capture interval.

The composite set of image data generated is provided to an image processing system. There, the IR light reflected by the physical object is used to recognize a characteristic of the physical object. Furthermore, a projector is preferably positioned on the first side of the light-permeable surface and is usable to present images on the opposite side of the light-permeable surface. A physical object on the opposite side of the light-permeable surface can thus interact with an image presented thereon.

#### BRIEF DESCRIPTION OF THE DRAWING FIGURES

The foregoing aspects and many of the attendant advantages of this invention will become more readily appreciated as the same becomes better understood by reference to the following detailed description, when taken in conjunction with the accompanying drawings, wherein:

FIG. 1 is a functional block diagram of a generally conventional computing device or personal computer (PC) that is suitable for image processing for the interactive display surface as used in practicing the present invention;

FIG. 2 is a cross-sectional view of a table-type interactive display surface, illustrating internal components;

FIG. 3 is an isometric view of an embodiment of the table-type interactive display surface that is coupled to an external PC;

FIGS. 4A, 4C, and 4E each show an enlarged cross-sectional view of a portion of the display surface, with a hand adjacent to the display surface illuminated by IR light from a controlled IR source and/or ambient IR light, while FIGS. 4B, 4D, and 4 F show resulting images captured from the display surface based upon reflected IR light from the hand;

FIG. 5 is a block diagram of a system for reducing the effect of undesired IR sources according to an embodiment of the present invention; and

FIG. 6 is a flow diagram illustrating the logical steps for reducing the effect of undesired IR illumination according to an embodiment of the present invention.

#### DESCRIPTION OF THE PREFERRED EMBODIMENT

##### Exemplary Computing System for Implementing Present Invention

With reference to FIG. 1, an exemplary system suitable for implementing various portions of the present invention is shown. The system includes a general purpose computing device in the form of a conventional PC 20, provided with a processing unit 21, a system memory 22, and a system bus 23: The system bus couples various system components including the system memory to processing unit 21 and may be any of several types of bus structures, including a memory bus or memory controller, a peripheral bus, and a local bus using any of a variety of bus architectures. The system memory includes read only memory (ROM) 24 and random access memory (RAM) 25. A basic input/output system 26 (BIOS), containing the basic routines that help to transfer information between elements within the PC 20, such as during start up, is stored in ROM 24. PC 20 further includes a hard disk drive 27 for reading from and writing to a hard disk (not shown), a magnetic disk drive 28 for reading from or writing to a removable magnetic disk 29, and an optical disk drive 30 for reading from or writing to a removable optical disk 31, such as a compact disk-read only memory (CD-ROM) or other optical media. Hard disk drive 27, magnetic disk drive 28, and optical disk drive 30 are connected to system bus 23 by a hard disk drive interface 32, a magnetic disk drive interface 33, and an optical disk drive interface 34, respectively. The drives and their associated computer readable media provide nonvolatile storage of computer readable machine instructions, data structures, program modules, and other data for PC 20. Although the exemplary environment described herein employs a hard disk, removable magnetic disk 29, and removable optical disk 31, it will be appreciated by those skilled in the art that other types of computer readable media, which can



## 5

store data and machine instructions that are accessible by a computer, such as magnetic cassettes, flash memory cards, digital video disks (DVDs), Bernoulli cartridges, RAMs, ROMs, and the like, may also be used in the exemplary operating environment.

A number of program modules may be stored on the hard disk, magnetic disk **29**, optical disk **31**, ROM **24**, or RAM **25**, including an operating system **35**, one or more application programs **36**, other program modules **37**, and program data **38**. A user may enter commands and information in PC **20** and provide control input through input devices, such as a keyboard **40** and a pointing device **42**. Pointing device **42** may include a mouse, stylus, wireless remote control, or other pointer, but in connection with the present invention, such conventional pointing devices may be omitted, since the user can employ the interactive display for input and control. As used hereinafter, the term “mouse” is intended to encompass virtually any pointing device that is useful for controlling the position of a cursor on the screen. Other input devices (not shown) may include a microphone, joystick, haptic joystick, yoke, foot pedals, game pad, satellite dish, scanner, or the like. These and other input/output (I/O) devices are often connected to processing unit **21** through an I/O interface **46** that is coupled to the system bus **23**. The term I/O interface is intended to encompass each interface specifically used for a serial port, a parallel port, a game port, a keyboard port, and/or a universal serial bus (USB). System bus **23** is also connected to a camera interface **59**, which is coupled to an interactive display **60** to receive signals from a digital video camera that is included therein, as discussed below. The digital video camera may be instead coupled to an appropriate serial I/O port, such as to a USB version 2.0 port. Optionally, a monitor **47** can be connected to system bus **23** via an appropriate interface, such as a video adapter **48**; however, the interactive display table of the present invention can provide a much richer display and interact with the user for input of information and control of software applications and is therefore preferably coupled to the video adaptor. It will be appreciated that PCs are often coupled to other peripheral output devices (not shown), such as speakers (through a sound card or other audio interface—not shown) and printers.

The present invention may be practiced on a single machine, although PC **20** can also operate in a networked environment using logical connections to one or more remote computers, such as a remote computer **49**. Remote computer **49** may be another PC, a server (which is typically generally configured much like PC **20**), a router, a network PC, a peer device, or a satellite or other common network node, and typically includes many or all of the elements described above in connection with PC **20**, although only an external memory storage device **50** has been illustrated in FIG. **1**. The logical connections depicted in FIG. **1** include a local area network (LAN) **51** and a wide area network (WAN) **52**. Such networking environments are common in offices, enterprise wide computer networks, intranets, and the Internet.

When used in a LAN networking environment, PC **20** is connected to LAN **51** through a network interface or adapter **53**. When used in a WAN networking environment, PC **20** typically includes a modem **54**, or other means such as a cable modem, Digital Subscriber Line (DSL) interface, or an Integrated Service Digital Network (ISDN) interface for establishing communications over WAN **52**, such as the Internet. Modem **54**, which may be internal or external, is connected to the system bus **23** or coupled to the bus via I/O device interface **46**, i.e., through a serial port. In a networked environment, program modules, or portions thereof, used by PC **20** may be stored in the remote memory storage device. It will be

## 6

appreciated that the network connections shown are exemplary and other means of establishing a communications link between the computers may be used, such as wireless communication and wide band network links.

## 5 Exemplary Interactive Surface

In FIG. **2**, an exemplary interactive display table **60** is shown that includes PC **20** within a frame **62** and which serves as both an optical input and video display device for the computer. In this cut-away Figure of the interactive display table, rays of light used for displaying text and graphic images are generally illustrated using dotted lines, while rays of infrared (IR) light used for sensing objects on or just above a display surface **64a** of the interactive display table are illustrated using dash lines. Display surface **64a** is set within an upper surface **64** of the interactive display table. The perimeter of the table surface is useful for supporting a user’s arms or other objects, including objects that may be used to interact with the graphic images or virtual environment being displayed on display surface **64a**.

IR light sources **66** preferably comprise a plurality of IR light emitting diodes (LEDs) and are mounted on the interior side of frame **62**. The IR light that is produced by IR light sources **66** is directed upwardly toward the underside of display surface **64a**, as indicated by dash lines **78a**, **78b**, and **78c**. The IR light from IR light sources **66** is reflected from any objects that are atop or proximate to the display surface after passing through a translucent layer **64b** of the table, comprising a sheet of vellum or other suitable translucent material with light diffusing properties. Although only one IR source **66** is shown, it will be appreciated that a plurality of such IR sources may be mounted at spaced-apart locations around the interior sides of frame **62** to provide an even illumination of display surface **64a**. The infrared light produced by the IR sources may:

- 35 exit through the table surface without illuminating any objects, as indicated by dash line **78a**;
- illuminate objects on the table surface, as indicated by dash line **78b**; or
- 40 illuminate objects a short distance above the table surface but not touching the table surface, as indicated by dash line **78c**.

Objects above display surface **64a** include a “touch” object **76a** that rests atop the display surface and a “hover” object **76b** that is close to but not in actual contact with the display surface. As a result of using translucent layer **64b** under the display surface to diffuse the IR light passing through the display surface, as an object approaches the top of display surface **64a**, the amount of IR light that is reflected by the object increases to a maximum level that is achieved when the object is actually in contact with the display surface.

A digital video camera **68** is mounted to frame **62** below display surface **64a** in a position appropriate to receive IR light that is reflected from any touch object or hover object disposed above display surface **64a**. Digital video camera **68** is equipped with an IR pass filter **86a** that transmits only IR light and blocks ambient visible light traveling through display surface **64a** along dotted line **84a**. A baffle **79** is disposed between IR source **66** and the digital video camera to prevent IR light that is directly emitted from the IR source from entering the digital video camera, since it is preferable that this digital video camera should produce an output signal that is only responsive to the IR light reflected from objects that are a short distance above or in contact with display surface **64a** and corresponds to an image of IR light reflected from objects on or above the display surface. It will be apparent that digital video camera **68** will also respond to any IR light included in the ambient light that passes through display



surface **64a** from above and into the interior of the interactive display (e.g., ambient IR light that also travels along the path indicated by dotted line **84a**).

IR light reflected from objects on or above the table surface may be:

reflected back through translucent layer **64b**, through IR pass filter **86a** and into the lens of digital video camera **68**, as indicated by dash lines **80a** and **80b**; or

reflected or absorbed by other interior surfaces within the interactive display without entering the lens of digital video camera **68**, as indicated by dash line **80c**.

Translucent layer **64b** diffuses both incident and reflected IR light. Thus, as explained above, “hover” objects that are closer to display surface **64a** will reflect more IR light back to digital video camera **68** than objects of the same reflectivity that are farther away from the display surface. Digital video camera **68** senses the IR light reflected from “touch” and “hover” objects within its imaging field and produces a digital signal corresponding to images of the reflected IR light that is input to PC **20** for processing to determine a location of each such object, and optionally, the size, orientation, and shape of the object. It should be noted that a portion of an object (such as a user’s forearm) may be above the table while another portion (such as the user’s finger) is in contact with the display surface. In addition, an object may include an IR light reflective pattern or coded identifier (e.g., a bar code) on its bottom surface that is specific to that object or to a class of related objects of which that object is a member. Accordingly, the imaging signal from digital video camera **68** can also be used for detecting each such specific object, as well as determining its orientation, based on the IR light reflected from its reflective pattern, in accord with the present invention. The logical steps implemented to carry out this function are explained below.

PC **20** may be integral to interactive display table **60** as shown in FIG. 2, or alternatively, may instead be external to the interactive display table, as shown in the embodiment of FIG. 3. In FIG. 3, an interactive display table **60'** is connected through a data cable **63** to an external PC **20** (which includes optional monitor **47**, as mentioned above). As also shown in this Figure, a set of orthogonal X and Y axes are associated with display surface **64a**, as well as an origin indicated by “0.” While not specifically shown, it will be appreciated that a plurality of coordinate locations along each orthogonal axis can be employed to indicate any location on display surface **64a**.

If the interactive display table is connected to an external PC **20** (as in FIG. 3) or to some other type of external computing device, such as a set top box, video game, laptop computer, or media computer (none shown), then the interactive display table comprises an input/output device. Power for the interactive display table is provided through a power lead **61**, which is coupled to a conventional alternating current (AC) line source (not shown). Data cable **63**, which connects to interactive display table **60'**, can be coupled to a USB 2.0 port, an Institute of Electrical and Electronics Engineers (IEEE) 1394 (or Firewire) port, or an Ethernet port on PC **20**. It is also contemplated that as the speed of wireless connections continues to improve, the interactive display table might also be connected to a computing device such as PC **20** via such a high speed wireless connection, or via some other appropriate wired or wireless data communication link. Whether included internally as an integral part of the interactive display, or externally, PC **20** executes algorithms for processing the digital images from digital video camera **68** and executes software applications that are designed to use the more intuitive user interface functionality of interactive

display table **60** to good advantage, as well as executing other software applications that are not specifically designed to make use of such functionality, but can still make good use of the input and output capability of the interactive display table.

As yet a further alternative, the interactive display can be coupled to an external computing device, but include an internal computing device for doing image processing and other tasks that would then not be done by the external PC.

An important and powerful feature of the interactive display table (i.e., of either embodiments discussed above) is its ability to display graphic images or a virtual environment for games or other software applications and to enable an interaction between the graphic image or virtual environment visible on display surface **64a** and objects that are resting atop the display surface, such as an object **76a**, or are hovering just above it, such as an object **76b**. It is the ability of the interactive display table to visually detect such objects, as well as the user’s finger or other object being moved by the user that greatly facilitates this rich interaction.

Again referring to FIG. 2, interactive display table **60** includes a video projector **70** that is used to display graphic images, a virtual environment, or text information on display surface **64a**. The video projector is preferably of a liquid crystal display (LCD) or digital light processor (DLP) type, or a liquid crystal on silicon (LCoS) display type, with a resolution of at least 640×480 pixels. An IR cut filter **86b** is mounted in front of the projector lens of video projector **70** to prevent IR light emitted by the video projector from entering the interior of the interactive display table where the IR light might interfere with the IR light reflected from object(s) on or above display surface **64a**. A first mirror assembly **72a** directs projected light traveling from the projector lens along dotted path **82a** through a transparent opening **90a** in frame **62**, so that the projected light is incident on a second mirror assembly **72b**. Second mirror assembly **72b** reflects the projected light onto translucent layer **64b**, which is at the focal point of the projector lens, so that the projected image is visible and in focus on display surface **64a** for viewing.

Alignment devices **74a** and **74b** are provided and include threaded rods and rotatable adjustment nuts **74c** for adjusting the angles of the first and second mirror assemblies to ensure that the image projected onto the display surface is aligned with the display surface. In addition to directing the projected image in a desired direction, the use of these two mirror assemblies provides a longer path between projector **70** and translucent layer **64b**, and more importantly, helps in achieving a desired size and shape of the interactive display table, so that the interactive display table is not too large and is sized and shaped so as to enable the user to sit comfortably next to it.

The foregoing and following discussions describe an interactive display device in the form of interactive display table **60** and **60'**. Nevertheless, it is understood that the interactive display surface need not be in the form of a generally horizontal table top. The principles described in this description of the invention suitably also include and apply to display surfaces of different shapes and curvatures and that are mounted in orientations other than horizontal. Thus, although the following description refers to placing physical objects “on” the interactive display surface, physical objects may be placed adjacent to the interactive display surface by placing the physical objects in contact with the display surface, or otherwise adjacent the display surface.

IR Images Captured with and without a Controlled IR Source  
Although interactive display table **60** (FIG. 2) employs an IR pass filter **86a**, this filter only excludes non-IR light from reaching the IR video camera. Extraneous IR light signals



also should be limited or compensated to prevent these undesired signals from interfering with the functioning of the interactive display table 60. FIGS. 4A-4F show a portion of an interactive display table to illustrate how unintended IR signals can distort an IR-spectrum image of a user's hand 402 engaging an interactive surface 64a.

FIG. 4A shows user's hand 402 partially touching and partially "hovering" over display surface 64a. An IR imaging system can respond to and differentiate between physical objects touching the interactive display surface and physical objects hovering proximate to the display surface, as described in commonly assigned, co-pending U.S. patent application Ser. No. 10/814,761, entitled "Determining Connectedness And Offset Of 3D Objects Relative To An Interactive Surface," which was filed on Mar. 31, 2004, the specification and drawings of which are hereby specifically incorporated herein by reference.

More particularly, in FIGS. 4A, 4C, and 4E, thumb 404 and middle finger 408 of user's hand 402 are touching interactive display surface 64a, while index finger 406 and ring finger 410 "hover" a short distance above interactive display surface 64a, and little finger 412 hovers slightly further away from interactive display surface 64a.

In FIG. 4A, beams of IR light 414 emanating from IR light source 66 pass through interactive display surface 64a and are incident on user's hand 402. Beams of reflected IR light 416 pass back through interactive display surface 64a, continuing through IR band pass filter 86a and into IR video camera 68. The IR video camera produces a signal corresponding to an image of the IR light entering the camera. This image is a function of IR light beams 416 and any other IR light that reach the IR video camera. In FIG. 4A, the only source of IR light is IR source 66; there are no unintended ambient or extraneous IR light sources in FIG. 4A. Baffle 79 prevents IR light from IR source 66 from directly entering the lens of IR video camera 68.

FIG. 4B shows the resulting IR-image of user's hand 402a produced by IR video camera 68 in response only to beams of IR light 416 for IR source 66 that are reflected by user's hand 402. In response to beams of reflected IR light 416, user's hand 402a has a greater intensity or brightness than that of the background 420a in this image. Further, tips of thumb 404a and middle finger 408a have a greater intensity or brightness than the rest of fingers 406a, 410a, and 412a, and the rest of hand 402a, in the image. Tips of thumb 404a and middle finger 408a are the only parts of hand 402a touching display surface 64a (FIG. 4A), so that the IR light reflected from the tips of the thumb and middle finger suffers less reduction due to the diffusion of interactive display surface 64a and therefore have a greater intensity than the rest of hand 402a or background 420a. Although only two distinct intensity levels are shown in FIG. 4B, it will be appreciated, however, that the intensity of the reflected IR light will vary based on the reflectivity of a physical object and its distance from interactive display surface 64a.

In FIG. 4C, IR source 66 is deactivated. Thus, unlike the illustration in FIG. 4A, beams of IR light 414 are not projected toward user's hand 402, and there are no beams of IR light 416 reflected from the user's hand toward IR video camera 68. However, unlike the illustration of FIG. 4A, FIG. 4C shows beams of IR light 422 and 424 originating beyond interactive display surface 64a, which are captured by IR video camera 68. For example, IR beams 422 might represent IR light emanating from any incandescent light source in the ambient environment of the interactive display table, and IR beams 424 might represent beams of IR light included in sunlight illuminating the ambient environment through a

window (not shown). Beams of IR light 422 and 424 pass around user's hand 402 and between user's fingers 404-412, continuing through IR band pass filter 86a. The "backlighting" of user's hand 402 therefore results in an image that includes a shadow of user's hand 402 against a brighter background 420b, as shown in FIG. 4D.

In FIG. 4D, user's hand 402 is dark—not bright and illuminated as in FIG. 4B. IR light coming only from behind user's hand 402 appears much brighter than the user's hand in this image, so that the user's hand appears only as a shadow against brighter background 420b. The image of FIG. 4D is understandably like that of a person standing with the sun behind the person, so that the person is backlit by the sun. The diffuse rays of backlighting result in a rather homogeneous shadowy image of the person against a much brighter background. As can be seen in FIG. 4D, there is no distinction between the images of finger tips of thumb 404b and middle finger 408b and the rest of the image of hand 402b and fingers 406b, 410b, and 412b as there is in FIG. 4B. Thus, the backlighting of user's hand with ambient IR light, at a minimum, tends to reduce the contrast between touching and hovering digits and hand, and may substantially reduce the useful image processing of an image that includes user's hand 402. In general, any segmentation of the image, i.e., labeling each pixel as being part of the user's hand or not, or any pixel as part of an object placed on the interactive display surface or not is more difficult under these conditions. The ambient light levels can easily match those of the reflected IR light from the IR light source. In general, it is possible to read the surface appearance of any object (since the ambient light does not impact the light returned from objects if they are opaque), thus it is not possible to rely on contours and shapes, or on the absolute pixel intensities in an image as an indication of what object is in contact with the interactive display surface.

In FIG. 4E, IR source 66 is once again activated as in FIG. 4A. This time, however, ambient IR sources are also active, so that, for example, ambient IR light from incandescent light 422 and sunlight 424 are also present. As shown in FIG. 4E, projected beams of IR light 414 reach user's hand 402 and fingers 404-412 from IR source 66, and reflected beams of IR light 416 from the hand and fingers reach IR video camera 68. At the same time, ambient IR light 422 and 424, shining around user's hand 402 and through user's fingers 404-412, also reaches the IR video camera. Again, none of beams 416, 422, and 424 are blocked by IR band pass filter 86a.

The resulting image of FIG. 4F shows that IR light beams 416 reflected from the user's hand and ambient IR light beams 422 and 424 may effectively offset each other. As a result, contrast may be substantially reduced, not only between the tips of user's fingers 404c and 408c touching interactive display surface 64a and the rest of user's hand 402c and fingers 406c, 410c, and 412c, but in general, between user's hand 402c and fingers 404c-412c, and background 420c. Background 420c will be bright as in FIG. 4D, and the user's fingers 404c and 408c will be discernible, due to the reflected IR from the IR light source. Also, user's hand 402c will be evident as a shadow relative to the bright ambient background. If beams of reflected IR light 416 from the user's hand are of substantially greater intensity than the beams of ambient IR light 422 and 424, the image of user's hand 402c and fingers 404c-412c still might stand out as brighter than background 420c. Active adjustment of the intensity of IR source 66 would have to be made to account for beams of ambient light 422 and 424 while attempting to preserve contrast between of the tips of fingers 404c and 408c that are touching interactive display surface 64a and the background illuminated by ambient IR light beams 422 and 424.



Accordingly, the present invention compensates for the effects of undesired and/or unintended ambient sources of IR light such as external incandescent light **422** and sunlight **424** by creating a composite set of imaging data from which the ambient sources of IR light are substantially removed. Again referring to FIGS. **4B**, **4D**, and **4E**, what is desired is to achieve the equivalent of the image of FIG. **4B**, where only reflected beams of IR light **416** (FIG. **4A**) are received at IR video camera **68**. Unfortunately, except by substantially eliminating most of the ambient IR light in the environment, external sources of IR light **422** and **424** will typically be included, along with reflected beams of IR light **416**, resulting in an image more like that of FIG. **4F** unless the presence of the ambient IR light is compensated. Without providing appropriate compensation, whenever there are ambient IR sources present in the environment, the undesired background in the image of FIG. **4D** will always be added to the desired image of IR light reflected from objects as in FIG. **4B**, yielding an image with the problems of FIG. **4F**.

While the image of FIG. **4B** cannot be naturally captured except in an isolated setting, the environments of FIGS. **4C** and **4E** can be selectively achieved in a typical setting. FIG. **4C** shows an environment in which extraneous IR light beams **422** and **424** produce the image of FIG. **4D**, which can be captured when IR source **66** is deactivated. FIG. **4E** shows a typical environment that includes both reflected IR light beams **416** (when IR source **66** is activated) and extraneous IR light beams **422** and **424**. Thus, the image of FIG. **4F** can be captured when IR source **66** is selectively activated in the presence of extraneous IR light. Since the image of FIG. **4F** is the compilation of the image resulting from desired reflected IR light of FIG. **4B** and the image resulting from undesired extraneous IR light of FIG. **4D**, subtracting the image of FIG. **4D** from the image of FIG. **4F** should yield the image of FIG. **4B**, thereby compensating for the extraneous or ambient IR light.

Thus, the desired image generally like that of FIG. **4B** can be achieved in a typical environment by collecting two sets of image data. A first set of image data is collected with IR source **66** activated and with any existing ambient or extraneous IR sources present. A second set of image data is also collected with IR source **66** deactivated. The second set of image data collected is then subtracted pixel by pixel from the first set of image data, yielding a compensated set of image data that includes only reflected IR light beams generated by the IR source; the extraneous sources are effectively excluded. Ideally, the first and second sets of image data are collected rapidly and sequentially to, as closely as possible, provide differently illuminated images of the same conditions on the interactive display surface.

A preferred embodiment of the present invention does not attempt to reduce the effect of unintended IR sources based upon static ambient IR measurements or an initial calibration. Accordingly, at the commencement of image acquisition by the IR video camera, there is no delay for image calibration. In addition, the present invention adapts better to changes in ambient IR sources and light levels than a static calibration or compensation method can. For example, if a user were asked to remove physical objects from the interactive display surface for image calibration then directed to continue using the interactive display surface, the calibration data would not take into account how the presence of physical objects added to the interactive display surface after its calibration may block signals from ambient IR sources. The present invention, however, takes into consideration the IR shadows, such as that shown in FIG. **4D**, which are caused by physical objects blocking ambient IR sources. Thus, the present invention

generates image data presenting a greater IR contrast at such points than if the IR image captured with the IR source activated was compared to a static IR source image that was captured without the physical object present.

Furthermore, the present invention continually appropriately accounts for and responds to changes in ambient IR sources and IR light in the environment. As a result, changes in ambient IR sources, such as a room light being turned on or off, or the intensity of sunlight passing through a window changing because of variation in the weather, the passing of time changing sun angles, or a window shade being moved, do not hamper the effectiveness of the reduction of unintended IR sources by the present invention. Similarly, even more transient changes in light from ambient IR sources, for example, resulting from a person walking between the interactive display surface and a lamp or a window, are compensated by the present invention.

System for Generating Image Data to Reduce Effects of Undesired IR Sources

FIG. **5** shows a system **500** for generating composite imaging data in which the effects of undesired IR light sources are substantially compensated. System **500** works with interactive display surface **64a**. PC **20** (shown in FIGS. **1-3**) carries out the functions of image processing and includes a storage device **516**. The PC processes the images produced by the IR video camera to detect the presence and/or movement of a user's finger **408** or other physical object disposed on or adjacent to the interactive display surface.

As previously described in connection with FIGS. **4A**, **4C**, and **4E**, IR source **66** is selectively activated to direct IR light beams **414** toward interactive display surface **64a**. Reflected IR light beams **416**, as well as beams of ambient IR light from incandescent light **422** and sunlight **424** pass through interactive display surface **64a**, continuing through IR band pass filter **86a** and are detected by a sensor **502** in IR video camera **68**.

IR video camera **68** includes an image capture synchronization output **504** that produces an image capture signal at the inception of each image capture interval. The image capture signal is received by an IR source controller **506**, which activates IR source **66** at every other image capture interval. For example, if the frame rate of the IR video camera is X frames per second, the effective rate for activating IR source **68** is X/2 times per second. As a result, every other image frame captured by IR video camera **68** and conveyed as a signal from data output port **508** will include reflected IR beams **416** and ambient IR beams **422** and **424**, while every alternative image frame will include only ambient IR beams **422** and **424**. This approach is currently used in a preferred embodiment, but other approaches could instead be employed. The IR video camera and the IR source could be driven synchronously by PC **20**, which could issue a command to activate or deactivate the IR source, and then immediately acquire a frame with the IR video camera. Or a special circuit could be provided to maintain the synchronization. In the embodiment discussed above, it is preferable to drive the IR video camera with a clock and simply synch from its output pulse, as a matter of convenience.

A typical video camera captures a total of 30 frames per second. Accordingly, 15 composite sets of imaging data are captured each second by combining 15 frames that are captured with IR source **66** activated with 15 frames that are captured with IR source **66** deactivated. It will be appreciated that higher frame rates are preferable. The more frames per second that are captured, the more accurately will the frames



captured with IR source 66 activated and IR source 66 deactivated represent how objects appeared at interactive display surface 64a in time.

In one embodiment of the present invention, the images output through data output port 508 are stored in a data buffer memory 510. Each frame is tagged according to whether the frame was captured with the IR source on, or off. Tagging of frames is suitably accomplished by setting a flag to indicate whether the frames were captured with the IR source on or off. Alternatively, frames can be tagged if the IR source is activated only on odd-numbered or only on even-numbered frames. In a current preferred embodiment, the intensity of a frame is evaluated by summing the pixel intensities over the image and comparing the sum of the intensities from one frame to the next. The frame with the greater sum of intensities is the "on" frame. Alternatively, it would be possible to place a white target at a known location on the underside of the apron surrounding interactive display surface 64a, so that by examining the pixel intensity in the known location, it can readily be determined if the IR source was active in a given frame.

From data buffer memory 510, frames are divided by a frame separator 512 that separates the frames as a function of whether the IR source was activated when a frame was captured. Frames for which the IR source was activated are routed to a positive side of a summer 514, while frames for which the IR source 66 was deactivated are routed to a negative side of summer 514, so that value for each point or pixel in each frame where the only IR illumination resulted from ambient IR sources can be subtracted from the corresponding value for that point or pixel where both IR source 66 was activated and ambient IR sources were present. Pixelwise subtracting the "IR source off" frames from the "IR source on" frames results in composite imaging data having IR values representing only the reflected IR light from IR source 66, substantially excluding the effect of ambient IR illumination.

More particularly, points of the respective images are pixelwise subtracted at summer 514 according to Eq. (1), as follows:

$$D(x,y)=I_{ON}(x,y)-I_{OFF}(x,y) \quad (1)$$

where:

x,y represents a coordinate location of a point on the interactive side of the light-permeable; surface;

$I_{ON}(x,y)$  represents intensity of IR light detected during the first image capture interval at point x,y;

$I_{OFF}(x,y)$  represents intensity of IR light detected during the second image capture interval at point x,y; and

$D(x,y)$  represents the net intensity of IR light at point x,y when the intensity of the IR light captured at the point x,y during the second image capture interval is subtracted from the intensity of the IR light captured at the point x,y during the first image capture interval.

Once the corresponding IR source 66 activated and IR source deactivated frame pairs are combined at summer 514, the composite set of imaging data generated is passed to image processing or storage, so that characteristics of one or more physical objects 408 present on or proximate to the interactive display surface can be processed and the results used by the interactive display system.

Method for Generating Image Data to Reduce Effects of Undesired IR Sources

FIG. 6 is a flow diagram 600 illustrating exemplary logical steps for substantially eliminating or reducing the effects of undesired IR illumination according to the present invention. At a step 602, IR imaging of the interactive display surface begins. At a step 604, the IR source is selectively synchro-

nized with the image acquisition signal generated by the IR video camera (or other imaging device that might alternatively be used). Selective IR source synchronization is desired because, as previously explained, the IR source is activated only during every other image acquisition interval.

At a step 606, the IR source is activated. At a step 608, the interactive display surface is imaged with the IR source turned on. At a step 610, the IR source is deactivated, and at a step 612, the interactive display surface is imaged with the IR source turned off. Using the image frames captured at steps 608 and 612, at a step 614 the image data captured for pairs of frames under these two different lighting conditions are pixelwise combined, as previously described in connection with FIG. 5 and Eq. (1) to compensate for the effect of light from unintended IR sources. After the image data are combined at step 614 to generate the composite data, at a step 616, the composite data are used for image processing, such as to detect physical objects on or adjacent to the interactive display surface, or the data are stored for later processing.

At a decision step 618, it is determined if IR imaging data are continuing to be captured. If so, the flow diagram loops to step 606, where the selective activation and deactivation and image capture continues. On the other hand, if it is determined at decision step 618 that the IR imaging is complete, the flow diagram proceeds to a step 620 and ends.

Although the present invention has been described in connection with the preferred form of practicing it and modifications thereto, those of ordinary skill in the art will understand that many other modifications can be made to the present invention within the scope of the claims that follow. Accordingly, it is not intended that the scope of the invention in any way be limited by the above description, but instead be determined entirely by reference to the claims that follow.

The invention in which an exclusive right is claimed is defined by the following:

1. An imaging system for reducing an effect of an undesired infrared light source using a desired infrared light source and an image capture device that detects emissions of both the undesired infrared light source and the desired infrared light, comprising:

a desired infrared light source that is positioned on a first side of a light permeable surface, the desired infrared light source selectively emitting desired infrared light that is transmitted through the light permeable surface onto a physical object positioned on or adjacent to an opposite side of the light permeable surface and is reflected back through the light permeable surface by the physical object;

an image capture device that is positioned on the same first side of the light permeable surface as the desired infrared light source, the image capture device sensing the desired infrared light after it is reflected by the physical object, and also sensing undesired infrared light that passes through the light permeable surface from undesired sources of infrared light located on the opposite side of the light permeable surface;

a screening device that is positioned on the same first side of the light permeable surface as the desired infrared light source and between the desired infrared light source and the image capture device to prevent the desired infrared light from entering the image capture device prior to being reflected back through the light permeable surface by the physical object;

a processor in communication with the desired infrared light source and the image capture device; and



## 15

a memory in communication with the processor, the memory storing data and machine instructions that cause the processor to carry out a plurality of functions, including:

- activating the desired infrared light source during a first image capture interval;
- capturing a first set of image data during the first image capture interval with the image capture device;
- deactivating the desired infrared light source during a second image capture interval;
- capturing a second set of image data during the second image capture interval with the image capture device;
- and
- generating a composite set of image data from the first and second set of image data to thereby substantially eliminate the undesired infrared light from the composite set of image data.

2. The system of claim 1, wherein the first values in the first set of image data represent an intensity of infrared light captured by the image capture device for a plurality of points across a plane of the light permeable surface during the first image capture interval while the desired infrared light source was activated, and the second values in the set of image data represent an intensity of infrared light captured by the image capture device for the plurality of points across the plane of the light permeable surface during the second image capture interval while the desired infrared light source was deactivated.

3. The system of claim 1, wherein generating the composite set of image data comprises subtracting from first values in the first set of image data, corresponding second values in the second set of image data, as defined by:

$$D(x,y)=I_{ON}(x,y)-I_{OFF}(x,y) \text{ where:}$$

- (a)  $x,y$  represents a coordinate location of a point on the plane;
- (b)  $I_{ON}(x,y)$  represents an intensity of infrared light detected by the image capture device during the first image capture interval at the point  $x,y$ ;
- (c)  $I_{OFF}(x,y)$  represents an intensity of infrared light detected by the image capture device during the second image capture interval at the point  $x,y$ ; and
- (d)  $D(x,y)$  represents a net intensity of infrared light at point  $x,y$  when the intensity of the infrared light captured at the point  $x,y$  during the second image capture interval is subtracted from the intensity of the infrared light captured at the point  $x,y$  during the first image capture interval.

4. The system of claim 1, wherein the machine instructions stored in the memory further cause the processor to use the desired infrared light reflected by the physical object to recognize a characteristic of the physical object.

5. An imaging system for reducing an effect of an undesired infrared light source using a desired infrared light source and an image capture device that detects emissions of both the undesired infrared light source and the desired infrared light, comprising:

- a desired infrared light source that is positioned on a first side of a light permeable surface, the desired infrared light source selectively emitting desired infrared light that is transmitted through the light permeable surface onto a physical object positioned on or adjacent to an opposite side of the light permeable surface and is reflected back through the light permeable surface by the physical object;

## 16

an image capture device that is positioned on the same first side of the light permeable surface as the desired infrared light source, the image capture device sensing the desired infrared light after it is reflected by the physical object, and also sensing undesired infrared light that passes through the light permeable surface from undesired sources of infrared light located on the opposite side of the light permeable surface, the image capture device further generating an image capture signal;

a screening device that is positioned on the same first side of the light permeable surface as the desired infrared light source and between the desired infrared light source and the image capture device to prevent the desired infrared light from entering the image capture device prior to being reflected back through the light permeable surface by the physical object;

an infrared light source controller configured to:

- receive the image capture signal; and
- selectively actuate the desired infrared light source in response to receipt of the image capture signal, such that the desired infrared light source is activated on receipt of a first image capture signal indicating a first image capture interval and deactivated on receipt of a second image capture signal indicating a second image capture interval;

a processor in communication with the desired infrared light source and the image capture device; and

a memory in communication with the processor, the memory storing data and machine instructions that cause the processor to carry out a plurality of functions, including:

- capturing a first set of image data with the image capture device during the first image capture interval;
- capturing a second set of image data with the image capture device during the second image capture interval; and
- generating a composite set of image data from the first and second set of image data to thereby substantially eliminate the undesired infrared light from the composite set of image data.

6. The system of claim 5, wherein first values in the first set of image data represent an intensity of infrared light captured by the image capture device for a plurality of points across a plane of the light permeable surface during the first image capture interval while the desired infrared light source was activated, and second values in the set of image data represent an intensity of infrared light captured for the plurality of points across the plane of the light permeable surface during the second image capture interval while the desired infrared light source was deactivated.

7. The system of claim 6, wherein generating the composite set of image data comprises subtracting from first values in the first set of image data, corresponding second values in the second set of image data, as defined by:

$$D(x,y)=I_{ON}(x,y)-I_{OFF}(x,y) \text{ where:}$$

- (a)  $x,y$  represents a coordinate location of a point on the plane;
- (b)  $I_{ON}(x,y)$  represents an intensity of infrared light detected during the first image capture interval at the point  $x,y$ ;
- (c)  $I_{OFF}(x,y)$  represents an intensity of infrared light detected during the second image capture interval at the point  $x,y$ ; and
- (d)  $D(x,y)$  represents a net intensity of infrared light at the point  $x,y$  when the intensity of the infrared light captured at the point  $x,y$  during the second image capture interval

**17**

is subtracted from the intensity of the infrared light captured at the point x,y during the first image capture interval.

**8.** The system of claim **5**, wherein the machine instructions stored in the memory further cause the processor to use the

**18**

desired infrared light reflected by the physical object to recognize a characteristic of the physical object.

\* \* \* \* \*