



US008133090B2

(12) **United States Patent**
Hardin

(10) **Patent No.:** **US 8,133,090 B2**
(45) **Date of Patent:** **Mar. 13, 2012**

(54) **DOLLS AND DOLL STANDS**
(75) Inventor: **Mark Hardin**, Austin, TX (US)
(73) Assignee: **Mattel, Inc.**, El Segundo, CA (US)

2,453,646 A 11/1948 Tomlin et al.
2,692,988 A 11/1954 Rouse
2,990,668 A 7/1961 Brendel
3,471,964 A * 10/1969 Cherry et al. 446/268
3,597,877 A * 8/1971 Speers 446/72
(Continued)

(*) Notice: Subject to any disclaimer, the term of this patent is extended or adjusted under 35 U.S.C. 154(b) by 298 days.

FOREIGN PATENT DOCUMENTS

GB 2081111 2/1982
(Continued)

(21) Appl. No.: **12/427,630**

(22) Filed: **Apr. 21, 2009**

OTHER PUBLICATIONS

U.S. Receiving Office, International Preliminary Report on Patentability regarding Application No. PCT/US2009/041285, Nov. 4, 2010, 5 pages.

(65) **Prior Publication Data**
US 2009/0264045 A1 Oct. 22, 2009

(Continued)

Related U.S. Application Data

(60) Provisional application No. 61/125,081, filed on Apr. 21, 2008.

Primary Examiner — Gene Kim
Assistant Examiner — Alexander Niconovich
(74) *Attorney, Agent, or Firm* — Kolisch Hartwell, PC

(51) **Int. Cl.**
A63H 3/50 (2006.01)
A63H 3/00 (2006.01)
(52) **U.S. Cl.** **446/331**; 446/268; 446/330; 428/24; 40/411
(58) **Field of Classification Search** 446/330, 446/331, 268; 428/24; 40/411
See application file for complete search history.

(57) **ABSTRACT**
A toy product including a doll and a display device that may be used with the doll is disclosed. The doll may have one or more movable features and may be releasably coupled to the display device. The display device may include an actuating assembly and a folding assembly with enclosure pieces that may alternately enclose and reveal the doll within the display device. The assemblies may communicate with each other and with movable features of the doll through selectively actuatable components. A locking member may engage and releasably retain the folding assembly in a retracted position and may return the folding assembly to an extended position upon disengagement. In the embodiments in which the enclosure pieces resemble flower petals, the movement of the enclosure pieces may have the effects of a flower bloom closing and opening up to respectively surround and reveal the doll.

(56) **References Cited**
U.S. PATENT DOCUMENTS
549,039 A * 10/1895 Wenger 40/411
1,407,165 A 2/1922 Pajeau
1,601,983 A 10/1926 Savage
1,916,988 A * 7/1933 Pieschke 40/412
2,155,665 A 4/1939 Leeper
2,280,467 A 4/1942 Blanc
2,380,175 A 7/1945 Hawkey
2,401,456 A 6/1946 Bresch
2,421,279 A 5/1947 Marty

21 Claims, 7 Drawing Sheets

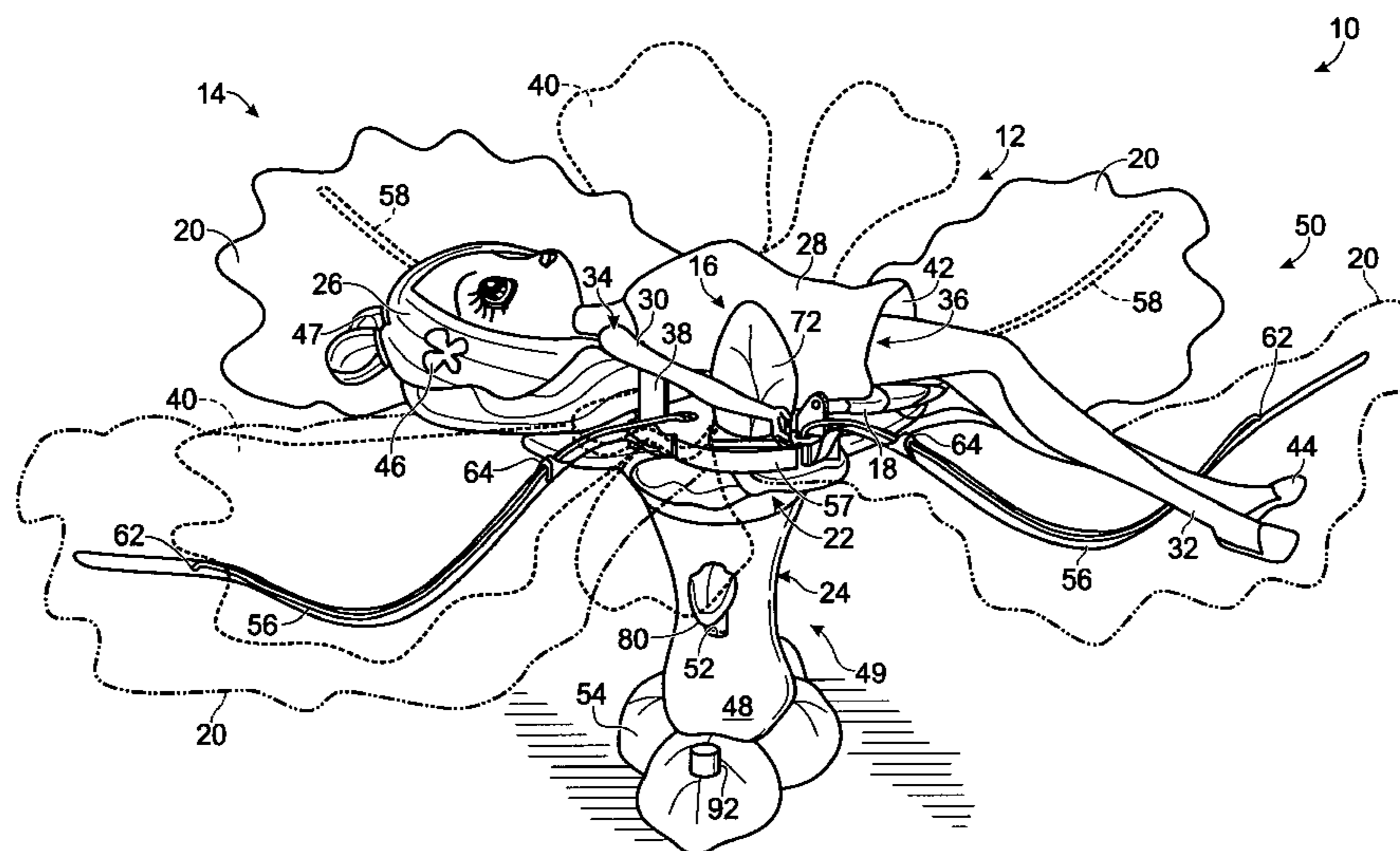

US 8,133,090 B2

Page 2

U.S. PATENT DOCUMENTS

3,828,467 A 8/1974 Kaelin
4,225,169 A 9/1980 DeToma
4,244,138 A 1/1981 Holahan et al.
4,268,918 A 5/1981 Lee
4,298,199 A 11/1981 Bush et al.
4,476,650 A 10/1984 Lokvig
4,571,206 A * 2/1986 Mayer et al. 446/330
4,575,349 A 3/1986 Piazza et al.
4,685,893 A 8/1987 Perkitny et al.
4,867,729 A * 9/1989 Weinman et al. 446/330
4,910,647 A * 3/1990 Gong 362/122
4,995,661 A 2/1991 Aurness et al.
5,090,569 A * 2/1992 Nissen et al. 206/457
5,167,562 A 12/1992 Axtell
5,378,188 A * 1/1995 Clark 446/330
5,522,758 A * 6/1996 Liu et al. 446/310
5,588,895 A 12/1996 Larson
5,624,320 A * 4/1997 Martinez 472/51
5,803,787 A 9/1998 Kulchyski
5,924,175 A 7/1999 Lippitt et al.
5,946,835 A * 9/1999 Boyd 40/412
5,964,638 A 10/1999 Emerson
6,012,962 A * 1/2000 Arriola 446/376
6,152,799 A 11/2000 Arriola
6,200,190 B1 3/2001 Reynolds
6,389,718 B1 * 5/2002 Joo 40/439

6,419,541 B1 7/2002 Apichom
6,574,915 B1 6/2003 Allen
7,175,497 B2 2/2007 Herzog
7,318,766 B2 * 1/2008 Marine et al. 446/359
7,338,342 B2 3/2008 Bellon
7,842,359 B2 * 11/2010 Marlow 428/24
7,861,444 B2 * 1/2011 Marlow 40/411
2004/0056492 A1 3/2004 Traber
2004/0080169 A1 4/2004 Khubani et al.
2004/0135387 A1 7/2004 Keith et al.
2004/0145196 A1 7/2004 Katz
2005/0057055 A1 3/2005 Deal
2005/0184540 A1 8/2005 Graziosi
2005/0191935 A1 9/2005 Marine et al.
2006/0160466 A1 7/2006 Bellon
2006/0172652 A1 8/2006 Herzog
2008/0042456 A1 2/2008 Patel

FOREIGN PATENT DOCUMENTS

WO 9318831 9/1993

OTHER PUBLICATIONS

The International Search Report from corresponding International Application Serial No. PC/US2009/041285, mailed on Jun. 16, 2009.

* cited by examiner

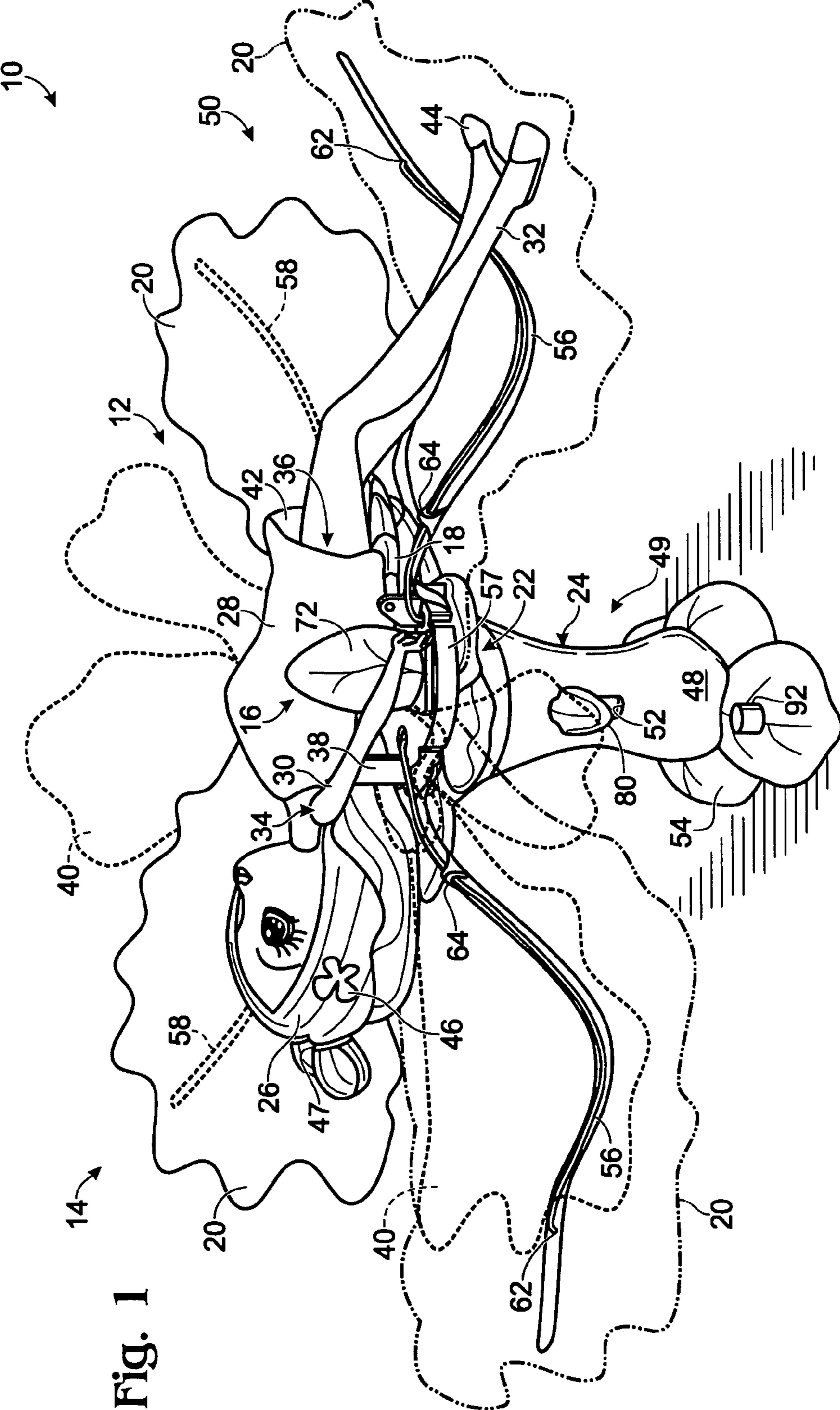

Fig. 1

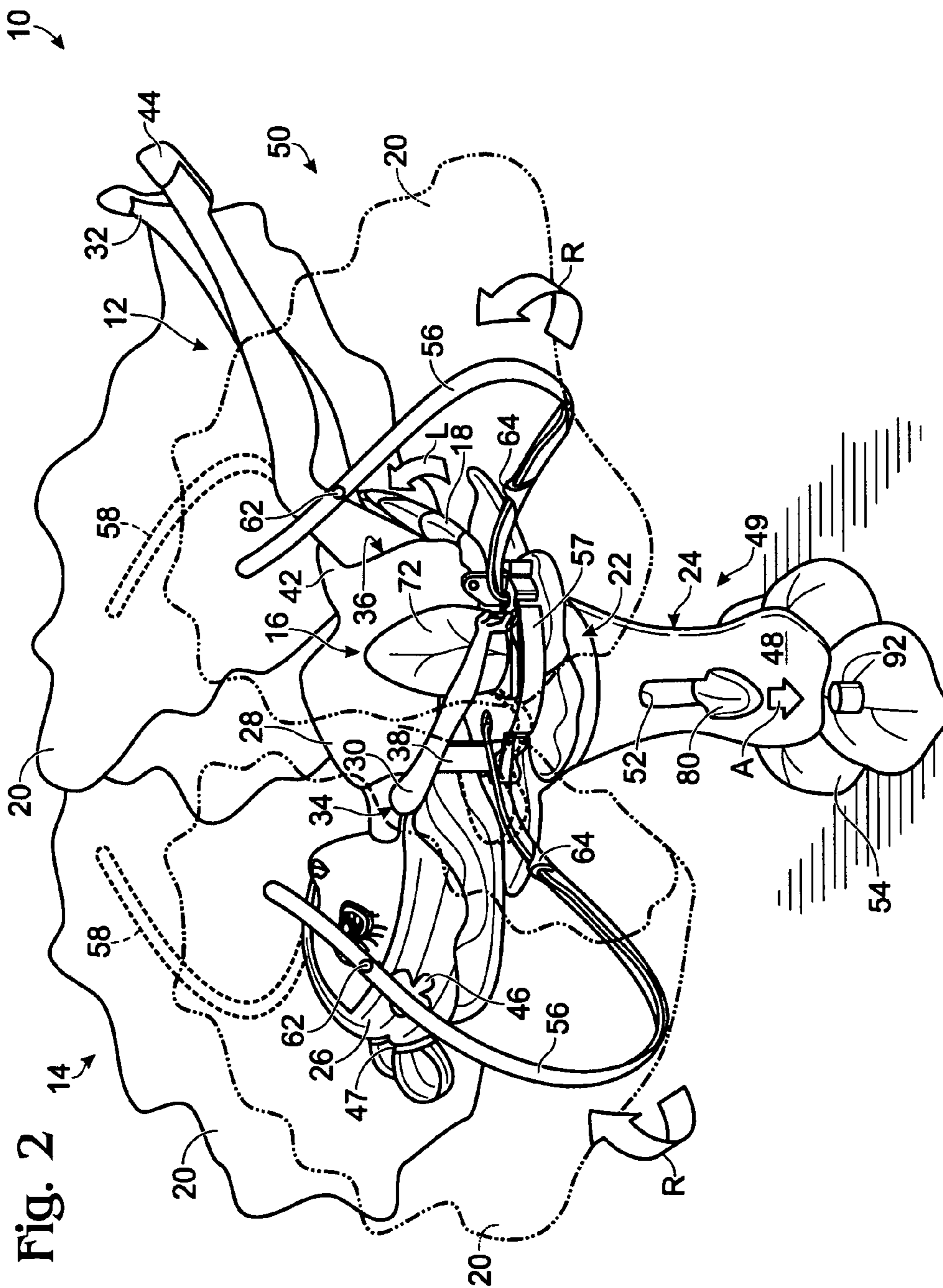

Fig. 2

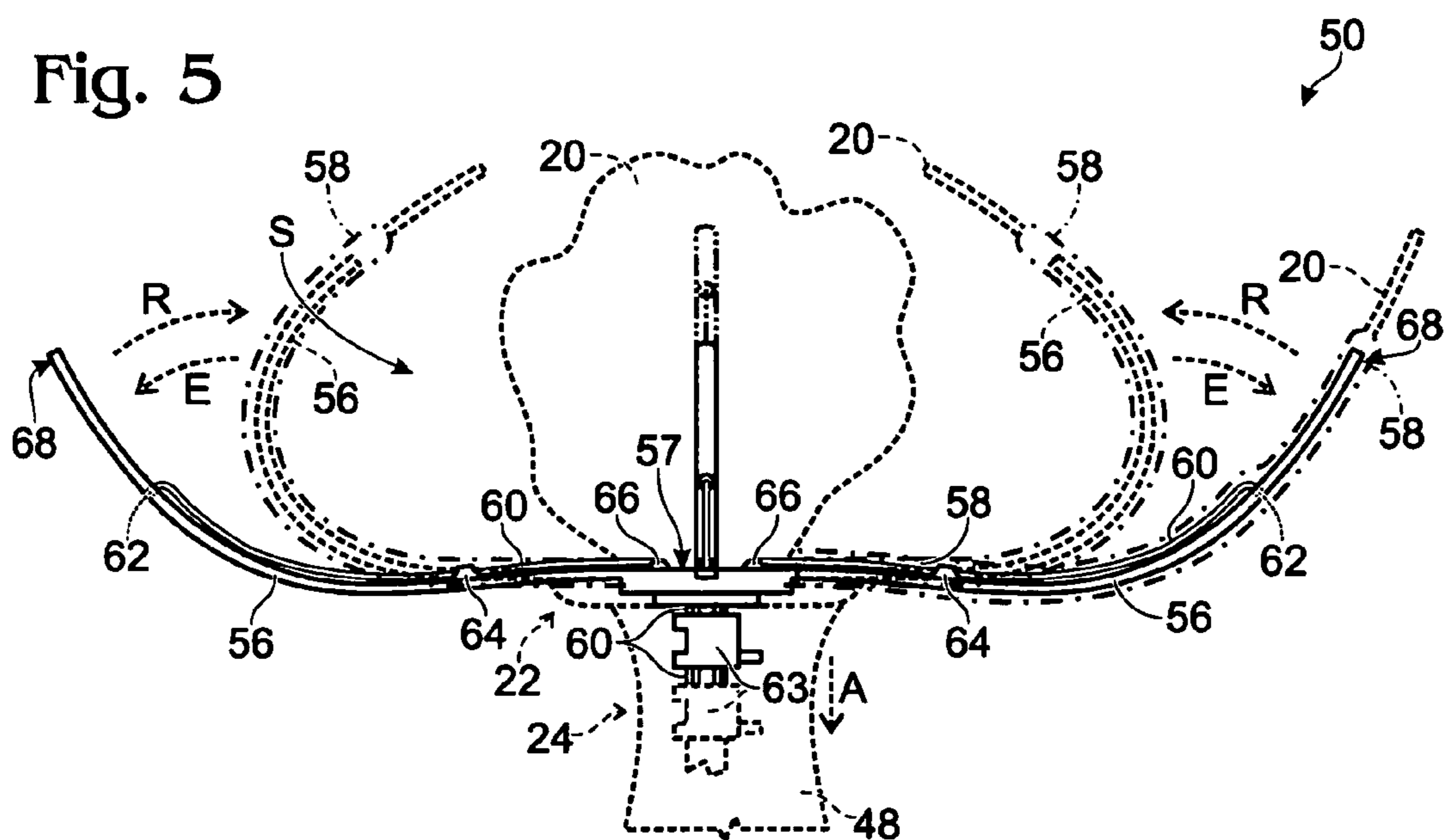
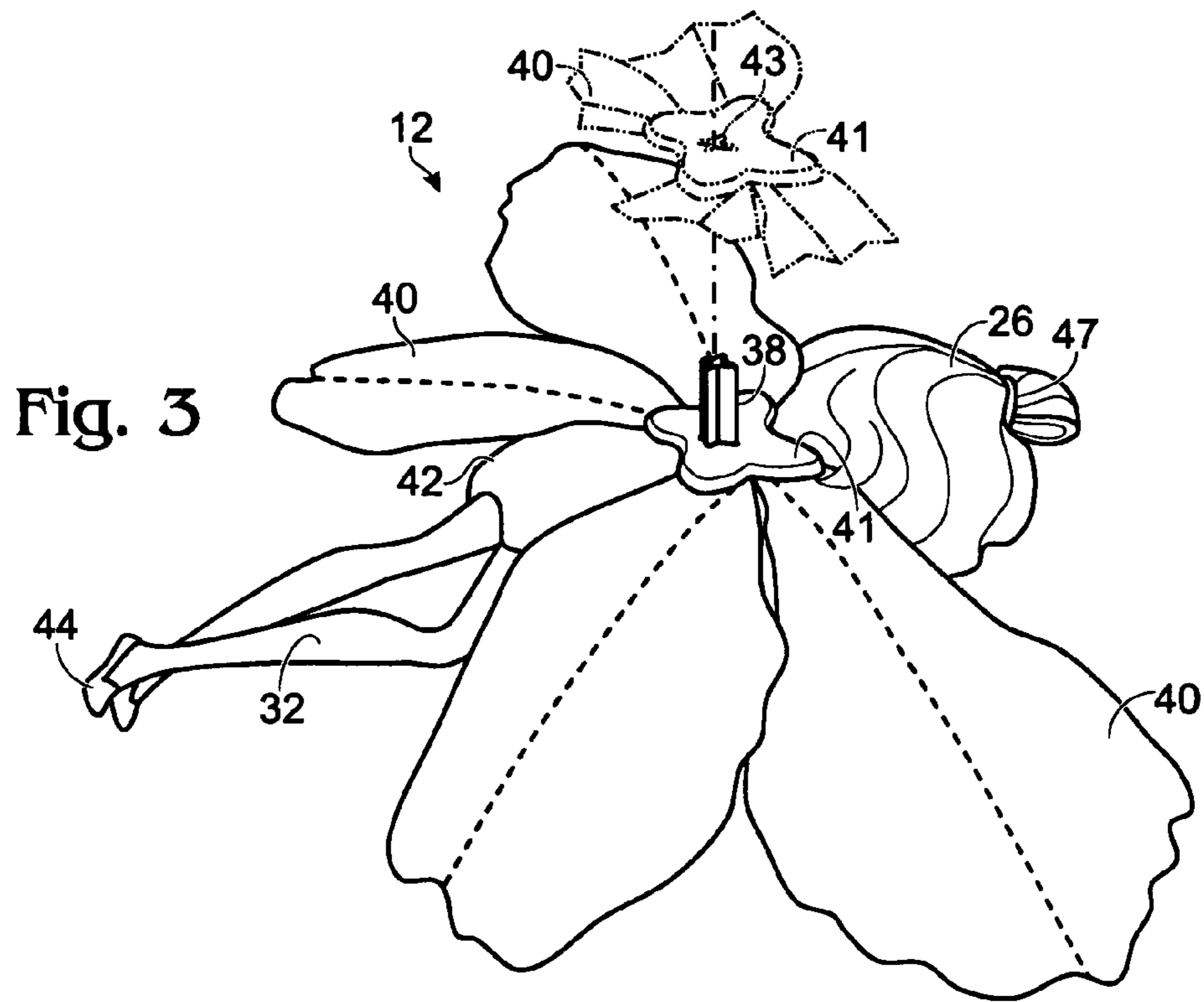

Fig. 4

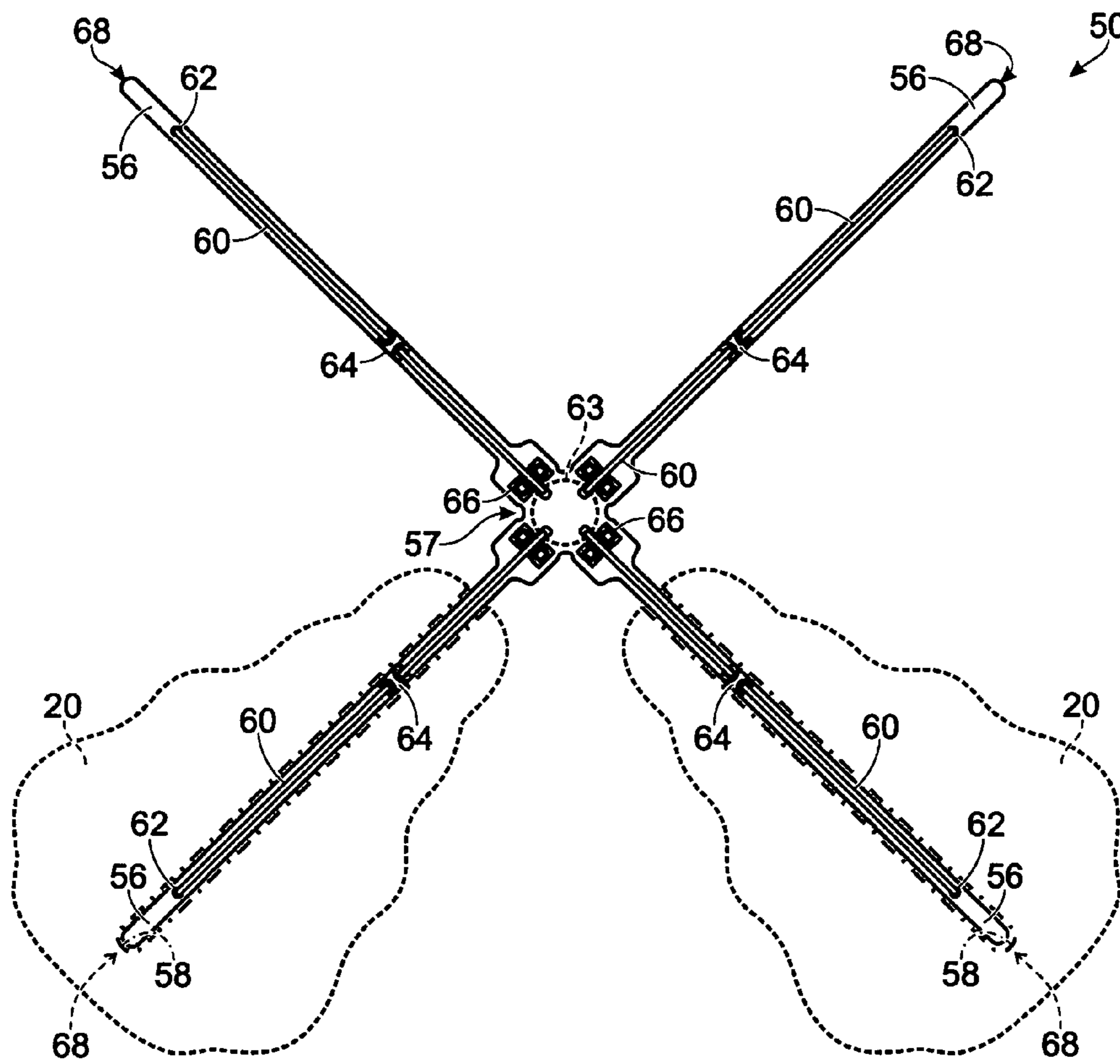

Fig. 6

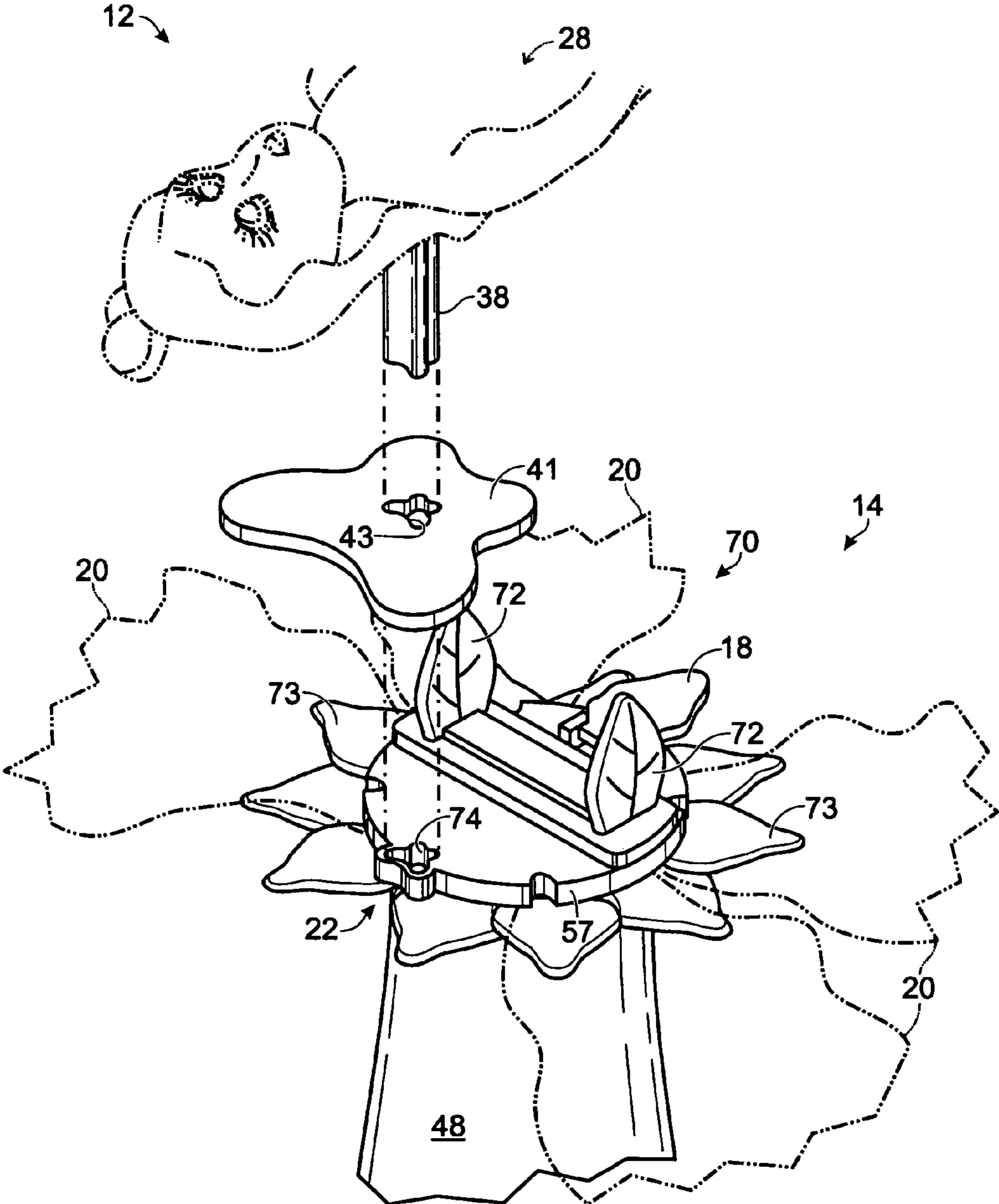

Fig. 7

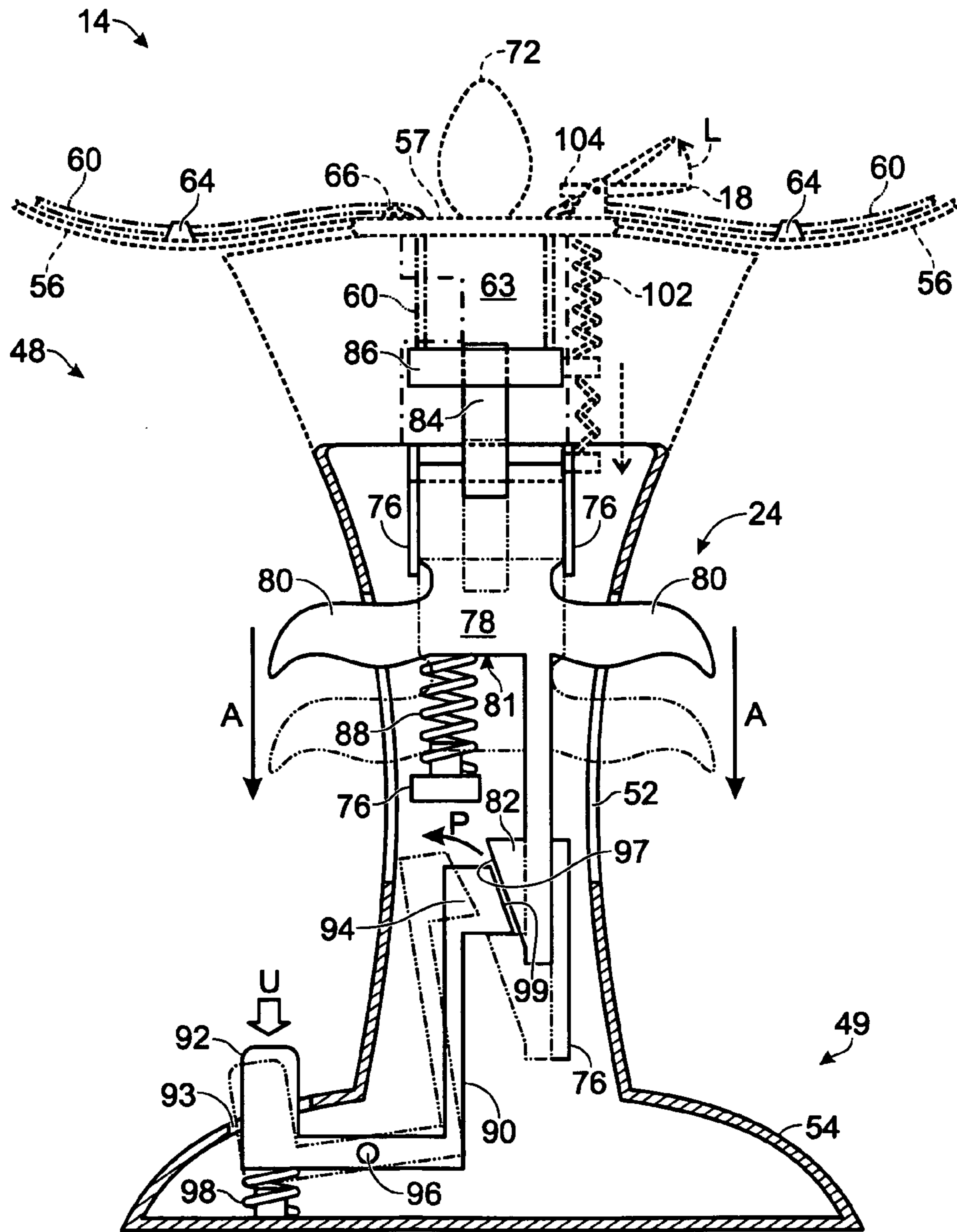

Fig. 8

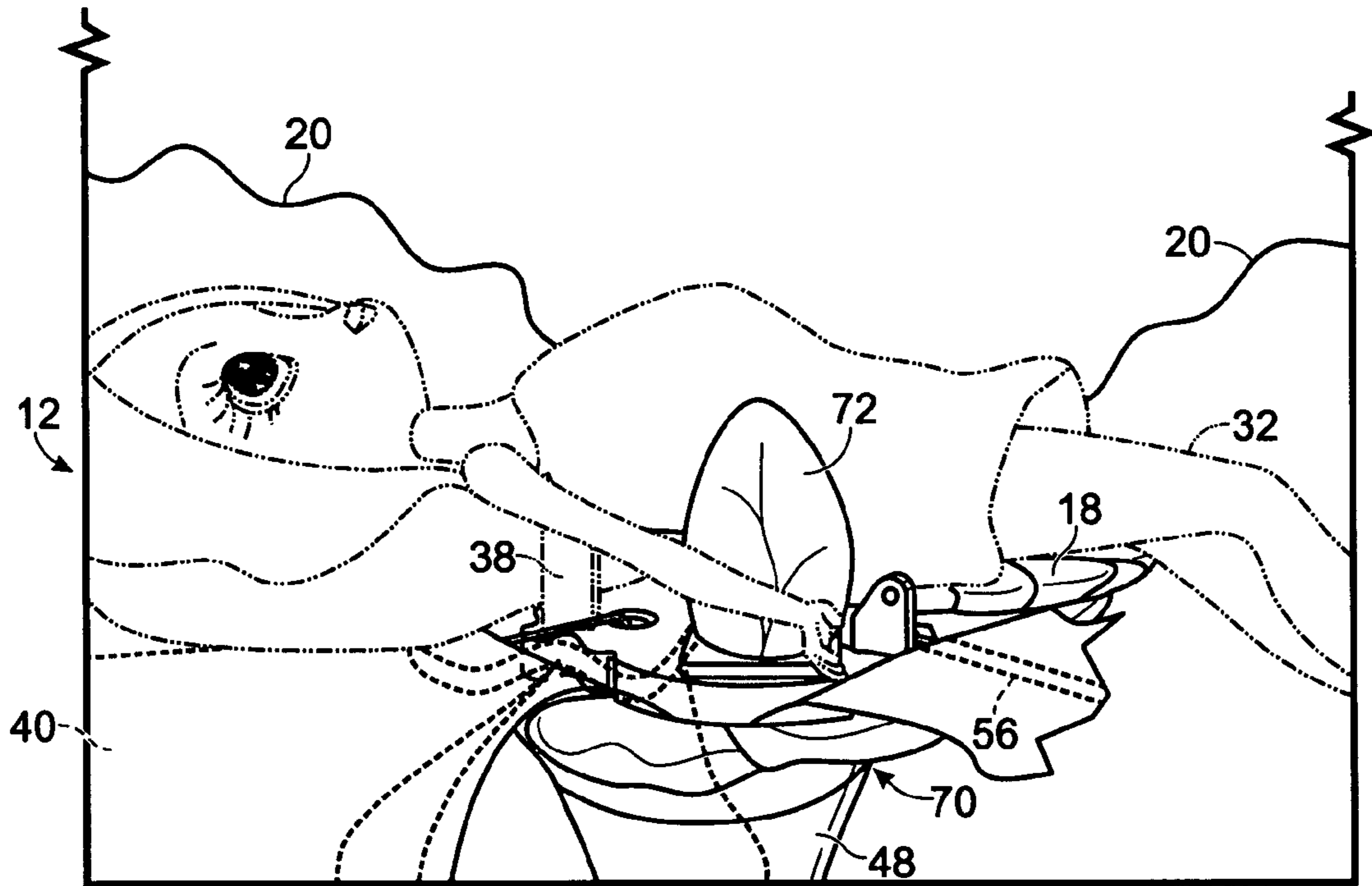
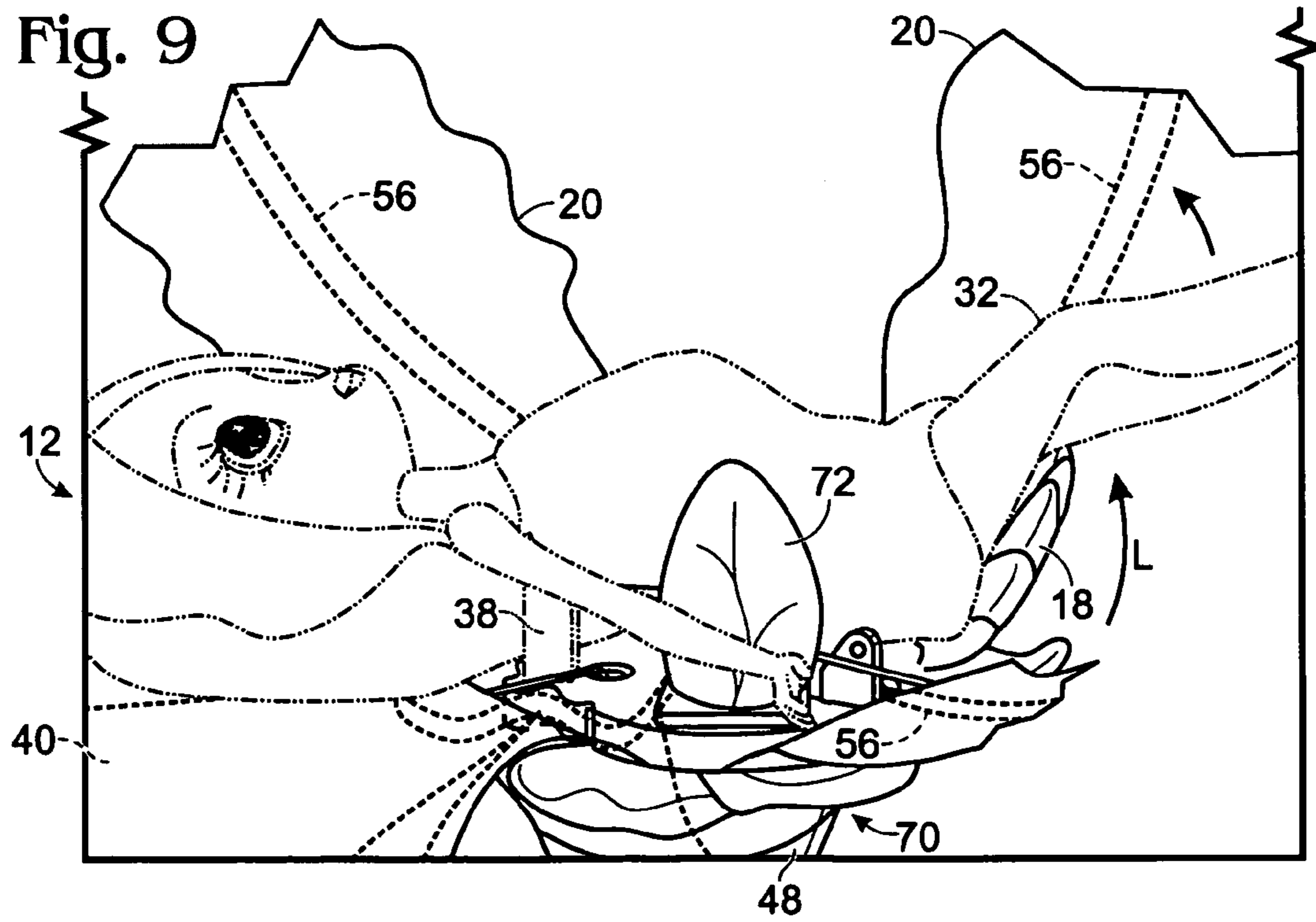

Fig. 9



DOLLS AND DOLL STANDS

CROSS-REFERENCES

The present application claims priority to provisional patent application Ser. No. 61/125,081, titled "DOLLS AND DOLL STANDS WITH SELECTIVELY ACTUABLE COMPONENTS," filed Apr. 21, 2008, the disclosure of which is incorporated herein by reference for all purposes.

BACKGROUND

The present disclosure is directed generally to interactive doll stands and, more particularly, to display devices to which dolls may be mounted, where the dolls and/or the display devices include one or more associated movable components that may be selectively actuated so as to substantially enclose the doll within the display device. Examples of interactive doll stands and devices with selectively actuable components are disclosed in U.S. Pat. Nos. 2,990,668, 4,298,199, 4,995,661, 6,874,833, 7,004,520, and 7,318,766. The disclosures of all the above-referenced patents are incorporated herein by reference in their entirety for all purposes.

SUMMARY

A toy product including a doll and a display device that may be used with the doll or other similarly configured character or persona is provided. The doll may have one or more movable features and may further include wings detachably coupled to the doll. An actuating assembly of the display device may communicate through one or more selectively actuable components with one or more movable features of the doll.

The actuating assembly may be operatively connected to a folding assembly that may alternately enclose and reveal the doll releasably mounted to the display device. The folding assembly may include one or more enclosure pieces that, in some embodiments, may be in the form of flower petals and may fold over the doll so as to form an enclosure and, thereby, substantially surround the doll. Each enclosure piece may have a sleeved portion configured to matingly receive a corresponding flexible member adapted to bend between an extended and retracted position in response to the operation of the actuating assembly. The bending of the flexible members may be facilitated by linkage elements operatively connecting the actuating assembly with each flexible member.

The actuating assembly may include an actuator and a locking member configured to releasably retain the folding assembly in the retracted position. The actuator may be partially or substantially housed within the display device and may be configured for transmitting a motion of the actuator to a reverse-blooming motion of the folding assembly.

In some embodiments, the actuating assembly may be actuated by manually pushing the actuator in the direction of actuation. The actuator may operatively engage and simultaneously pull the linkage elements so the flexible members and associated enclosure pieces move from the extended toward the retracted position. In the embodiments in which the enclosure pieces resemble flower petals, such movement of the pieces may have the effect of a flower closing up to surround the doll.

The flexible members and associated enclosure pieces may be releasably retained in the retracted position by way of a locking member, such as by releasably locking the actuator when the enclosure pieces are in the retracted position. The actuating assembly may further include a push-button that

may be configured to release the actuator and return the flexible members and associated enclosure pieces to the extended position. As a result, the folding assembly may unfold, thus, revealing the doll mounted to the display device.

In the embodiments in which the enclosure pieces resemble flower petals, such unfolding may have the effect of a flower bloom opening up.

The actuating assembly may further include a lifting member that may partially or substantially support one or more movable features of the doll. The lifting member may be operatively connected to the actuating assembly and may be configured so as to concomitantly lift or, otherwise, move one or more features of the doll as the enclosure pieces surround the doll. Thus, the lifting member may further facilitate enclosure of the doll within the display device.

The dolls and display devices of the present disclosure may be understood more readily after a consideration of the drawings and the Detailed Description.

BRIEF DESCRIPTION OF THE DRAWINGS

FIG. 1 is a perspective view of a toy product including a doll mounted on a display device, showing enclosure pieces of the display device in an extended position.

FIG. 2 is a perspective view of the toy product of FIG. 1 showing the enclosure pieces in a retracted position.

FIG. 3 is a rear elevation view of the doll of FIGS. 1-2 illustrating wings detachably coupled to the doll.

FIG. 4 is a simplified top view of a folding assembly of the display device of FIGS. 1-2.

FIG. 5 is a schematic side elevation view of the folding assembly of FIG. 4 illustrating extension and retraction of the folding assembly in response to operation of an actuating assembly.

FIG. 6 is a simplified perspective view of a mounting structure of the display device of FIGS. 1-2.

FIG. 7 is a simplified cut-away view of the actuating assembly of the display device of FIGS. 1-2.

FIG. 8 is a simplified perspective view of the mounting structure of FIG. 6 illustrating a lifting member associated with the actuating assembly of FIG. 7.

FIG. 9 is a simplified perspective view of the mounting structure of FIG. 6 illustrating the lifting member of FIG. 8 moving the doll's legs upwardly to a folded position upon actuation of the actuating assembly.

DETAILED DESCRIPTION

FIGS. 1-2 illustrate examples of a toy product 10 including a doll 12 and a display device 14. Doll 12 may be releasably retained within a mounting structure 16 and may be substantially or partially supported by a leaf-shaped lever or lifting member 18, as will be described in greater detail below. In the example shown, a plurality of enclosure pieces 20 may extend outwardly from an upper portion 22 of the display device and may resemble flower petals.

As seen in FIG. 2, enclosure pieces 20 may be moved to a retracted position, as indicated by arrows R, in response to operation of an actuating assembly 24 and may substantially enclose doll 12 within display device 14. As will be seen, lifting member 18 may further facilitate such enclosure by concomitantly lifting or otherwise moving one or more movable features of doll 12. It will be noted that terms of orientation used in the description apply when toy product 10 is in an operative position on a substantially horizontal surface, as

shown in FIGS. 1-2. When toy product 10 is in other orientations, these terms provide relative meaning, even though not literally accurate.

Toy product 10 may represent or further a particular theme and/or simulate a fictional or non-fictional story, as well as a traditional fairy tale. In the embodiments in which enclosure pieces 20 resemble flower petals, the movement of the enclosure pieces may have the effect of a flower closing up to surround the doll. As such, doll 14 may be perceived as a humanoid, such as a winged fairy, that lives in a flower that blooms and closes, as desired, to house or shelter the doll. Optionally or alternatively, toy product 10 may have no theme.

It should be appreciated that even though a plurality of flower-like petals is illustrated, enclosure pieces 20 may have any desired shape of form, and that display device 14 may include a single enclosure piece configured to substantially enclose doll 12, when in the retracted position of FIG. 2.

Doll 12 may be configured to represent a human-like character, licensed character, copyrighted character, or any other suitable fantasy or real-life character, as mentioned above. To simplify discussion, features of toy product 10 shown in FIGS. 1-2 that correspond to features of the examples illustrated in FIGS. 3-8 are given the same reference numbers.

Still referring to FIGS. 1-2, doll 12 may include, as major features, a head 26, a torso 28, arms 30, and legs 32 movably attached to respective shoulder and hip joints 34 and 36. Head 26 may be configured to be movable in any direction relative to torso 28 and may include human-like features with makeup and fashionable hair. Shoulder joints 34 and hip joints 36 of doll 12 may be configured so as to allow a wide degree of pivoting relative to torso 28.

Arms 30 may be movably secured to torso 28 in any conventional manner. In the configuration shown, arms 30 may be frictionally fit within shoulder joints 34 allowing each arm to pivot independently about the shoulder joints so as to enable posing of each arm at a variety of pivotal positions. Optionally or alternatively, arms 30 may be rigidly connected together via a shared arm connector for simultaneous rotation relative to torso 28 along a common substantially horizontal axis.

Legs 32 may be rotatably attached to a lower portion of torso 28 at hip joints 36 to enable for a wide degree of independent pivoting about a substantially horizontal axis. Under some circumstances, however, it may be preferable to limit the relative rotational movement of legs 32 at the respective hip joints of doll 12. Optionally or alternatively, legs 32 may be rigidly connected to each other via a shared leg connector for simultaneous rotation relative to torso 28. In addition, appropriate stoppers may be provided to effectively prevent the legs from being pivoted beyond prescribed points and/or to allow for a desired clearance with enclosure pieces 20 or other elements or members of display device 14.

As viewed more readily in FIG. 3, doll 12 may further include a pin or projection, such as, for example, an elongate projection 38 protruding outwardly from the back portion of the doll for releasably securing the doll within display device 14, as will be seen. In the present example, doll 12 is shown to further include wings 40 that may be shaped like butterfly wings and may be fixedly secured to a support plate 41 by appropriate means, such as, for example, thread, screws, bolts, nuts, clamps, clips, glue, and so forth. Wings 40 may comprise of one or more layers of flexible material or, alternatively, may include a flexible skeleton over which one or more layers of flexible material may be mounted to retain a particular shape of the wings.

Support plate 41 may include an aperture 43 that may be non-circular in cross-section and may correspond to the cross-section of elongate projection 38. Wings 40 may be detachably coupled to doll 12 by inserting elongate projection 38 into aperture 43 when the aperture and the projection are aligned, as shown in the dash-dotted line. The non-circular nature of both cross-sections may limit rotational movement of wings 40 relative to doll 12. Optionally or alternatively, wings 40 may not be detachable from doll 12.

As mentioned above with reference to FIGS. 1-2, doll 12 may additionally include a decorative bodice or dress 42, a pair of shoes 44, and one or more accessories to further a particular theme, as previously mentioned. For purposes of illustration, the accessories are shown to include a hair clip 46 and a hair band 47. While only a certain number of accessories in reference to the particular theme are illustrated in this example, doll 12 may include any number of accessories or no accessories, and any such accessories may be positioned anywhere within and/or next to doll 12. In addition, the dress, shoes, and/or accessories may or may not be removable from doll 12.

The various components of doll 12 may be fabricated from any suitable material, such as plastic, foamed plastic, flexible plastic, one or more layers of fabric, wood, cardboard, pressed paper, metal, or any combination of materials. A suitable material or combination of materials may be selected to provide a desirable synergy of weight, strength, durability, cost, and/or manufacturability.

Display device 14 may include actuating assembly 24 that may be partially or substantially housed within a base 48 and a folding assembly 50 supported by upper portion 22 of the base. In the configuration shown, base 48 may further include a lower portion 49 having a generally vertical tubular body. One or more contoured slotted openings 52 may be positioned on opposite sides of lower portion 49 to facilitate an actuation of actuating assembly 24, as will be described in greater detail below. As seen, display device 14 may be configured as a free-standing structure, and lower portion 49 of base 48, thus, may further include a flattened platform, such as a leaf-shaped platform 54, to stabilize the device in a standing position on a substantially horizontal surface.

FIG. 4 is a top view of folding assembly 50 in the extended position, and FIG. 5 illustrates the folding assembly moving between the extended and retracted positions. In the configuration shown, folding assembly 50 may include a plurality of enclosure pieces, indicated generally in dashed lines at 20, and a plurality of corresponding elongate flexible members 56 extending outwardly from a shaped platform 57. For purposes of illustration, folding assembly 50 is shown schematically with one or more enclosure pieces 20 omitted. The principles discussed with reference to the folding assembly with multiple enclosure pieces in FIGS. 4-5 are applicable to other embodiments of folding assemblies, such as, for example, assemblies with a single enclosure piece.

In the present example, each enclosure piece 20 may be fabricated from one or more layers of a soft material, such as fabric and/or flexible plastic, and may include a pocket or sleeved portion 58, indicated in dash-dotted lines, adapted to matingly receive corresponding flexible member 56 in a tightly-fitted relationship. It should be noted that flexible members 56 may be sufficiently resilient so as to facilitate moving of folding assembly 50 from the retracted position indicated by arrow R in FIG. 5 to the extended position of FIG. 4 upon disengagement of actuating assembly 24, as will be described below.

Folding assembly 50 may further include one or more linkage elements 60 that may be fixedly secured to a respec-

5

tive coupling element **62** and may operatively connect folding assembly **50** with actuating assembly **24** via a hub **63**, as particularly seen in the example of FIG. **5**. Linkage elements **60** may be affixed to hub **63** by appropriate means.

Linkage elements **60** may partially or substantially extend along the length of corresponding flexible member **56** and may be slidably engaged within a wedge-shaped retaining element **64**. Retaining elements **64** may be provided with one or more apertures and may be configured to have any desired shape and/or cross-section to further their particular function. In addition, folding assembly **50** may include one or more guides **66** to maintain linkage elements **60** in a predetermined orientation relative to flexible members **56**.

As shown in FIG. **5**, flexible members **56** may be slightly bowed and/or biased, when in the extended position, so as to enable bending of the members in a particular direction, such as, for example, in a retracting direction indicated by arrow **R**. Such bowing and/or biasing may be facilitated by sufficient resilient properties of flexible members **56** and/or by appropriate lengths of respective linkage elements **60** urging distal ends **68** of the corresponding flexible members upwardly and/or inwardly.

In operative use, actuating assembly **24** may engage hub **63** and, thus, simultaneously draw linkage elements **60** in the direction of actuation, schematically represented by arrow **A**. In turn, linkage elements **60**, slidably guided through respective retaining elements **64** and tightly-fit sleeved portions **58**, may engage respective coupling elements **62** to draw and to forceably bend associated flexible members **56** toward the retracted position, as indicated by arrow **R**. Upon disengagement, flexible members **56** may return to the extended position, as represented by arrow **E**, using the resilient properties of the members, or by way of gravity, or both. Optionally or alternatively, actuating assembly **24** may include a resilient member that may facilitate the return of flexible members **56** to the extended position, as will be seen.

As illustrated, retaining elements **64** may be configured to remain in substantially the same orientation relative to base **48** when flexible members **56** move—and associated enclosure pieces **20** follow—from the extended to the retracted position so as to create a substantially enclosed space **S** sufficient to surround doll **12**. This effect may be accomplished by placing retaining elements **64** on the associated flexible members at a desired distance from platform **57** and by a closely-spaced cooperating relationship between linkage elements **60**, flexible members **56**, and associated sleeved portions **58**. It should be appreciated that in some embodiments retaining elements **64** may be positioned closer or further away from platform **57** so as to create a smaller or larger space, respectively, depending on the size of doll **12**.

FIG. **6** illustrates an exemplary embodiment of a mounting structure **70** that may be supported by upper portion **22** of base **48** and may be used to releasably retain doll **12** within display device **14**. The doll's wings are not shown to make the parts therebehind visible.

As seen in this example, mounting structure **70** may include a plurality of leaf-shaped bracing members **72** that may have a slightly curved or arcuate shape and may extend upwardly from platform **57**. Bracing members **72** may be rigidly connected to the platform by appropriate means and may be spaced apart so as to frictionally retain torso **28** of doll **12** therebetween. As a way of illustration, platform **57** is shown to include a plurality of leaf-shaped elements **73** designed to further the theme of toy product **10**. Optionally or alternatively, platform **57** may have no theme-oriented design.

6

An irregularly-shaped aperture **74** may be formed within the upper portion of platform **57** and may have a non-circular cross-section that may correspond to cross-sections of elongate projection **38** of doll **12** and aperture **43** in support plate **41**. In assembled relationship, elongate projection **38** may be aligned with, as shown in dash-dotted lines, and may project through aperture **43** in support plate **41** so as to be matingly positioned within aperture **74**, thus, effectively linking doll **12** and display device **14** together. The non-circular nature of the cross-sections may help with self-alignment of doll **12** within display device **14** so as to facilitate correct positioning of the doll's legs on lifting member **18**, as will be seen.

FIG. **7** is a simplified cut-away view of actuating assembly **24** associated with display device **14** of FIGS. **1-2**. In the configuration shown, actuating assembly **24** may be partially or substantially housed within base **48** and may be secured by means of an inner support structure formed by a plurality of rigid support members **76**.

Actuating assembly **24** may include an actuator, such as a cross-shaped actuator **78** with one or more leaf-shaped actuator handles **80** projecting outwardly through associated slotted openings **52** in lower portion **49** of base **48**, as has been previously mentioned. Actuator **78** may be slidably retained within inner support members **76** to allow for a linear reciprocal motion and may further include a shoulder portion **81** and an angled locking portion **82**. As will be seen, actuating assembly **24** may be configured for transmitting a motion of actuator **78** to a reverse-blooming motion of folding assembly **50**.

In the configuration shown, a T-shaped end portion **84** of actuator **78** may operatively connect the actuator to folding assembly **50** via hub **63** by way of one or more inserts **86**. A resilient member, such as, for example, a compression spring **88** may be interposed between shoulder portion **81** of the actuator and inner support member **76** so as to bias actuator **78** upwardly.

Actuating assembly **24** may further include a locking member **90** with an integrally-formed push-button **92** protruding outwardly through an aperture **93** in platform **54**, and an angled tooth **94** adapted to engage and retain locking portion **82** of actuator **78**. Locking member **90** may be pivotally secured within platform **54** with a pin **96** so as to allow the limited amount of pivoting and may be biased upwardly by a compression spring **98**. It should be appreciated that any other resilient means may be used to bias push-button **92**, as well as actuator **78**, in suitable directions to further their particular functions.

In the present example, tooth **94** and locking portion **82** may include angled regions **97** and **99**, respectively. The angled regions may be configured such that a downward motion of actuator **78**, represented by arrow **A**, may bring the regions in contact, and may impart a forced pivoting of locking member **90** in the direction indicated by arrow **P**.

As previously discussed, actuating assembly **24** may further include lifting member **18** that may be pivotally secured to platform **57** by means of a fulcrum pin **100** so as to allow for a wide degree of pivoting about a substantially horizontal axis. Lifting member **18** may be operatively linked to actuator **78** by way of a tension spring **102** fixedly secured with one end to hub **63** and with another end to an effort arm **104** of lifting member **18**. It should be noted that any other appropriate means may be used to operatively connect lifting member **18** with actuator **78**.

During play, the actuation of actuating assembly **24** may cause the reverse blooming motion of folding assembly **50** and may substantially enclose doll **12** within display device **14**. In the present example, actuating assembly **24** may be

7

actuated by manually pushing handles **80** of actuator **78** in the direction of actuation, as indicated by arrow A. T-shaped end portion **84** of actuator **78** and, more specifically, inserts **86** may engage hub **63** to travel downward.

Since hub **63** is operatively connected to flexible members **56** by linkage elements **60**, the hub may simultaneously draw the linkage elements so as to bend flexible members **56** and associated enclosure pieces **20** of folding assembly **50** toward the retracted position, as has been described with reference to FIG. **5**. It should be appreciated that any other systems or configurations may be used to actuate actuating assembly **24**.

As actuator **78** travels downward, angled region **97** may contact and exert force against angled region **99**, thus, forcing locking member **90** to pivot about the axis of pin **96** against the biasing action of spring **98** in the counter-clockwise direction, as indicated by arrow P. Forced pivoting of locking member **90** may continue until actuator **78**, in its downward movement, passes a predetermined point, such as, for example, when angled region **97** completely passes angled region **99** of locking member **90**. As this occurs, locking member **90** may pivotally snap back in the clockwise direction due to the biasing action of spring **98** so as to engage locking portion **82** and, thus, retain actuator **78** in a lowered or locked position by tooth **94**.

Folding assembly **50**, thus, may be retained in the retracted position, as shown in FIGS. **2** and **5**, by the interconnection of actuator **78** with flexible members **56** via linkage elements **60**, as described above. It should be appreciated that other internal lock mechanisms may be used to releasably retain folding assembly **50** in the retracted position.

Exerting sufficient force on push-button **92**, as indicated by arrow U, may disengage locking member **90** and may return folding assembly **50** to the extended position, as shown in FIGS. **1** and **4**. When button **92** is depressed, locking member **90** may pivot in the counter-clockwise direction P and may cause tooth **94** to slip out of locking portion **82**. This may effectively release actuator **78**, and spring **88** may urge the actuator to travel upward, thus, loosening the tension of linkage elements **60** and returning folding assembly **50** to the extended position. As a result, folding assembly **50** may unfold, thus, revealing doll **12** mounted to display device **14**. In the embodiments in which the enclosure pieces resemble flower petals, such unfolding may have the effect of a flower bloom opening up.

As further seen in the examples of FIGS. **8-9**, when doll **12** is releasably retained or otherwise stationary positioned within mounting structure **70**, legs **32** of the doll may be partially or substantially supported by lifting member **18**. Because actuator **78** is operatively linked to lifting member **18**, as described with reference to FIG. **7**, the force exerted on spring **102** by downward motion of the actuator may cause the lifting member to pivot about fulcrum pin **100**, as indicated by arrow L. Therefore, as actuator **78** moves folding assembly **50** toward the retracted position, lifting member **18** may concomitantly move legs **32** of doll **12** upwardly to a folded position, as illustrated in FIG. **9**. Lifting member **18**, thus, may further facilitate sufficient enclosure of doll **12** within display device **14**.

While embodiments of a toy and methods of toy play have been particularly shown and described, many variations may be made therein. This disclosure may include one or more independent or interdependent embodiments directed to various combinations of features, functions, elements and/or properties. Other combinations and sub-combinations of features, functions, elements and/or properties may be claimed later in a related application. Such variations, whether they are directed to different combinations or directed to the same

8

combinations, whether broader, narrower or equal in scope, are also regarded as included within the subject matter of the present disclosure. Accordingly, the foregoing embodiments are illustrative, and no single feature or element, or combination thereof, is essential to all possible combinations that may be claimed in this or a later application.

Each example defines an embodiment disclosed in the foregoing disclosure, but any one example does not necessarily encompass all features or combinations that may be eventually claimed. Where the description recites "a" or "a first" element or the equivalent thereof, such description includes one or more such elements, neither requiring nor excluding two or more such elements. Further, ordinal indicators, such as first, second or third, for identified elements are used to distinguish between the elements, and do not indicate a required or limited number of such elements, and do not indicate a particular position or order of such elements unless otherwise specifically stated.

What is claimed is:

1. A toy display device, comprising:

a base;

a folding assembly supported by the base, the folding assembly comprising:

a flexible member extending from the base, the flexible member having a distal end, a retaining element, and a coupling element disposed between the retaining element and the distal end, the flexible member being adapted to bend between an extended position and a retracted position;

an enclosure piece supported by the flexible member and including a sleeved portion adapted to receive the flexible member;

a linkage element extending from the base along the flexible member, wherein the linkage element slidably engages the retaining element and is secured to the coupling element;

an actuating assembly supported by the base, wherein the actuating assembly is configured, upon actuation, to:

draw the linkage element toward the base, thereby bending the flexible member from the extended position to the retracted position.

2. The display device of claim **1**, wherein the retaining element includes at least one opening through which the linkage element extends.

3. The display device of claim **1**, wherein the coupling element moves toward the base, and the retaining element remains in substantially the same position relative to the base, upon actuation of the actuating assembly.

4. The display device of claim **1**, wherein the actuating assembly includes a guide configured to align the linkage element in a predetermined orientation relative to the flexible member.

5. The display device of claim **1**, wherein the actuating assembly includes a locking member configured to releasably retain the flexible member in the retracted position.

6. The display device of claim **5**, wherein the locking member is configured to releasably retain the linkage element after the linkage element has been drawn toward the base.

7. The display device of claim **1**, wherein the enclosure piece is configured to form a substantially enclosed space when the flexible member is in the retracted position.

8. The display device of claim **1**, wherein the base includes a mounting structure configured to releasably receive the toy.

9. The display device of claim **1**, wherein the actuating assembly further includes an actuator movably connected to the base, at least a portion of the actuator positioned to be

accessible from external the display device, the actuator being configured, when moved, to draw the linkage element toward the base.

10. A toy display device, comprising:

a base;

a folding assembly supported by the base, the folding assembly comprising:

a flexible member extending from the base, the flexible member having a distal end, a retaining element, and a coupling element disposed between the retaining element and the distal end, the flexible member being adapted to bend between an extended position and a retracted position;

a linkage element extending from the base along the flexible member, wherein the linkage element slidably engages the retaining element and is secured to the coupling element;

an enclosure piece supported by the flexible member, wherein the enclosure piece includes a sleeved portion adapted to receive the flexible member and is configured to form a substantially enclosed space when the flexible member is in the retracted position; and

an actuating assembly supported by the base, wherein the actuating assembly is configured, upon actuation, to draw the linkage element toward the base, thereby bending the flexible member from the extended position to the retracted position.

11. A toy product, comprising:

a doll;

a display device configured to detachably retain the doll, the display device further comprising:

a base;

a folding assembly, comprising:

a flexible member extending from the base and having a distal end;

an enclosure piece supported by the flexible member and having a sleeved portion adapted to receive the flexible member; and

a linkage element extending from the base along the flexible member, wherein the linkage element is secured to the flexible member at a point between the base and the distal end of the flexible member;

an actuating assembly supported by the base, wherein the actuating assembly is operable, upon actuation, to draw the linkage element toward the base, thereby bending the flexible member from the extended position toward the retracted position; and

wherein the enclosure piece substantially enclose the doll when the flexible member is in the retracted position.

12. The toy product of claim **11**, wherein the doll includes one or more moveable features.

13. The toy product of claim **11**, wherein the doll includes an elongate projection protruding from the doll, and wherein the display device includes a corresponding aperture configured to receive the elongate projection.

14. The toy product of claim **11**, wherein the display device further includes a mounting structure having one or more bracing members extending from and supported by the base and configured to releasably receive the doll.

15. The toy product of claim **11**, wherein the actuating assembly includes a lifting member supported by the base, the lifting member being operatively connected to the actuating assembly and configured for movement relative to the base.

16. The toy product of claim **15**, wherein the doll includes at least one moveable feature, and the lifting member is adapted to move the at least one movable feature upon actuation of the actuating assembly.

17. The toy product of claim **15**, wherein the doll includes at least one moveable feature, and the lifting member moves the at least one movable feature upon actuation of the actuating assembly, such that the at least one movable feature is enclosed within the enclosure piece.

18. A toy product, comprising:

a doll with movable human features having an elongate projection disposed on the doll and a pair of wings detachably coupled to the doll via the elongate projection;

a display device configured to detachably retain the doll, the display device further comprising:

a base having an upper portion, a lower portion, and an aperture within the upper portion, the aperture being configured to matingly receive the elongate projection to detachably couple the doll to the display device;

a folding assembly, comprising:

a plurality of elongate flexible members extending from the upper portion of the base, each configured to bend between an extended position and a retracted position, and each including a distal end, a retaining element, and a coupling element disposed therebetween;

a corresponding plurality of enclosure pieces, each enclosure piece having a sleeved portion configured to receive each flexible member;

a corresponding plurality of linkage elements extending from the upper portion of the base along each flexible member, wherein each linkage element slidably engages each retaining element and is secured to the coupling element of each flexible member;

an actuating assembly supported by the base, wherein the actuating assembly is operable upon actuation to draw the plurality of linkage elements towards the base, thereby bending each flexible member from the extended position toward the retracted position, and wherein such bending urges each distal end of each flexible member towards the base in a manner that creates a substantially enclosed space around the doll defined by the enclosure pieces.

19. The toy product of claim **18**, wherein the display device further includes a mounting structure supported by the upper portion of the base, the mounting structure having bracing members configured to receive and releasably retain the doll therebetween.

20. The toy product of claim **18**, wherein the base further includes a lever pivotally connected to the upper portion of the base, the lever being operatively coupled with the actuating assembly and configured, upon actuation, to:

move one or more movable human features to a folded position,

wherein such movement is concomitant with actuation of the actuating assembly, and

wherein the movable human features in the folded position are enclosed within the enclosure pieces.

21. The toy product of claim **18**, wherein the actuating assembly further includes a locking system supported by the base, wherein the locking system is configured to:

engage the actuating assembly when the actuating assembly passes a predetermined point, such that each flexible member is releasably retained in the retracted position; and

return each flexible member into the extended position upon disengagement.