

US008128626B2

(12) **United States Patent**
Justin

(10) **Patent No.:** **US 8,128,626 B2**
(45) **Date of Patent:** **Mar. 6, 2012**

- (54) **SYSTEM AND METHOD FOR DELIVERY CONFORMATION AND REMOVAL OF INTRAMEDULLARY BONE FIXATION DEVICES**
- (75) Inventor: **Daniel F. Justin**, Logan, UT (US)
- (73) Assignee: **Flexfix, LLC**, North Logan, UT (US)
- (*) Notice: Subject to any disclaimer, the term of this patent is extended or adjusted under 35 U.S.C. 154(b) by 940 days.

4,522,200 A	6/1985	Stednitz
4,721,103 A	1/1988	Freedland
4,854,312 A	8/1989	Raftopoulos
4,932,969 A	6/1990	Frey et al.
5,053,035 A	10/1991	McLaren
5,108,398 A	4/1992	McQueen et al.
5,108,404 A	4/1992	Scholten et al.
5,135,527 A	8/1992	Ender
5,281,225 A	1/1994	Vicenzi
5,364,398 A	11/1994	Chapman et al.
5,423,850 A	6/1995	Berger

(Continued)

FOREIGN PATENT DOCUMENTS

FR 2801189 11/1999

(Continued)

- (21) Appl. No.: **11/777,892**
- (22) Filed: **Jul. 13, 2007**

- (65) **Prior Publication Data**
US 2008/0269747 A1 Oct. 30, 2008

Related U.S. Application Data

- (60) Provisional application No. 60/913,696, filed on Apr. 24, 2007.

- (51) **Int. Cl.**
A61B 17/72 (2006.01)
- (52) **U.S. Cl.** 606/62; 606/86 R; 606/99
- (58) **Field of Classification Search** 606/62-68, 606/108, 194, 198, 86 R, 87-90, 99; 623/1.11, 623/1.15, 1.32, 1.44
See application file for complete search history.

- (56) **References Cited**

U.S. PATENT DOCUMENTS

4,177,524 A	12/1979	Grell et al.
4,204,531 A	5/1980	Aginsky
4,222,128 A	9/1980	Tomonaga et al.
4,262,665 A	4/1981	Roalstad et al.
4,268,468 A	5/1981	Esper et al.
4,453,539 A	6/1984	Raftopoulos et al.
4,457,301 A	7/1984	Walker

OTHER PUBLICATIONS

International Search Report and Opinion in PCT/US2008/061047 dated Nov. 14, 2008.

(Continued)

Primary Examiner — Eduardo C Robert
Assistant Examiner — Steven Cotroneo

- (57) **ABSTRACT**

A bone fixation system and method for stabilizing a fractured bone by implantation into the intramedullary canal of an implant that is expanded by an implant deformation apparatus, or deformer. The deformer can use mechanical, pneumatic, or hydraulic expansion. Some deformers apply or remove heat. Some implants may include a support structure and a thermo-chemically activated matrix. The support structure may be radially expandable and contractible, and sufficiently flexible to be inserted into the intramedullary canal through an opening which is not parallel to the intramedullary canal. The matrix may attain a first thermo-chemical state via the addition of energy, and a second thermo-chemical state via the dissipation of energy.

26 Claims, 25 Drawing Sheets

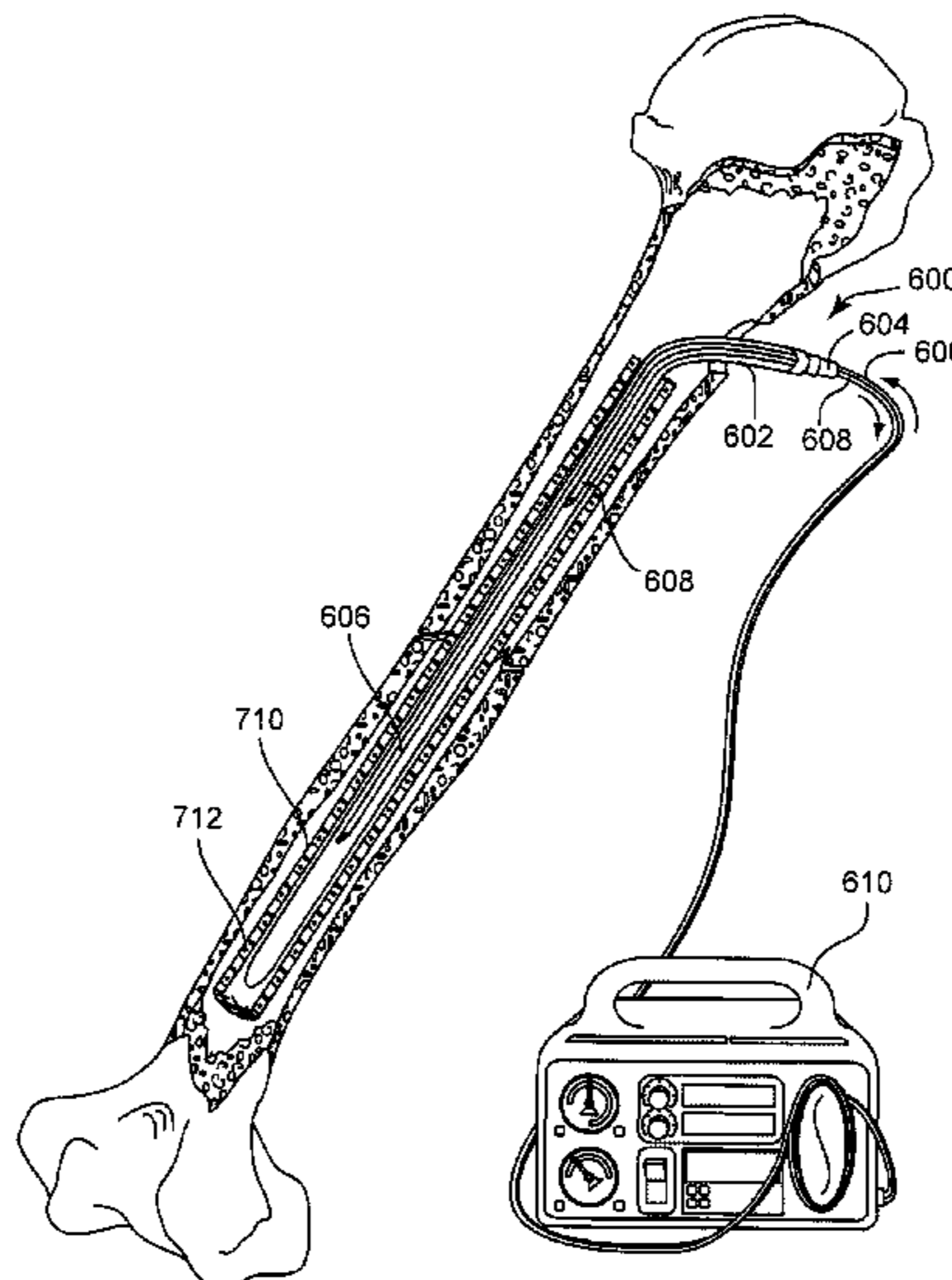

U.S. PATENT DOCUMENTS

5,480,400 A 1/1996 Berger
 5,501,695 A 3/1996 Anspach et al.
 5,620,445 A 4/1997 Brosnahan et al.
 5,653,709 A 8/1997 Frigg
 5,720,753 A 2/1998 Sander et al.
 5,725,541 A 3/1998 Anspach et al.
 5,782,865 A 7/1998 Grotz et al.
 5,849,004 A 12/1998 Bramlet et al.
 5,855,579 A 1/1999 James et al.
 6,083,244 A 7/2000 Lubbers et al.
 6,127,597 A 10/2000 Beyar et al.
 6,183,474 B1 2/2001 Bramlet et al.
 6,206,880 B1 3/2001 Karladani
 6,245,102 B1 6/2001 Jayaraman
 6,248,110 B1 6/2001 Reiley et al.
 6,261,289 B1* 7/2001 Levy 606/63
 6,299,635 B1 10/2001 Frantzen
 6,312,455 B2 11/2001 Duerig et al.
 6,371,989 B1 4/2002 Chauvin et al.
 6,423,067 B1 7/2002 Eisermann
 6,475,237 B2 11/2002 Drasler et al.
 6,491,718 B1 12/2002 Ahmad
 6,506,211 B1 1/2003 Skubitz et al.
 6,551,321 B1 4/2003 Burkinshaw et al.
 6,554,833 B2 4/2003 Levy et al.
 6,582,453 B1 6/2003 Tran et al.
 6,613,081 B2 9/2003 Kim et al.
 6,626,937 B1 9/2003 Cox
 6,682,554 B2 1/2004 Oepen et al.
 6,709,454 B1 3/2004 Cox et al.
 6,736,818 B2 5/2004 Perren et al.
 6,746,477 B2 6/2004 Moore
 6,746,479 B2 6/2004 Ehr et al.
 6,755,862 B2 6/2004 Keynan
 6,761,731 B2 7/2004 Majercak
 6,764,506 B2 7/2004 Roubin et al.
 6,764,507 B2 7/2004 Shanley et al.
 6,770,088 B1 8/2004 Jang
 6,770,089 B1 8/2004 Hong et al.
 6,776,793 B2 8/2004 Brown et al.
 6,783,530 B1* 8/2004 Levy 606/63
 6,790,227 B2 9/2004 Burgermeister
 6,805,706 B2 10/2004 Solovay et al.
 6,808,561 B2 10/2004 Genge et al.
 6,866,805 B2 3/2005 Hong et al.
 6,896,696 B2 5/2005 Doran et al.
 6,911,048 B2 6/2005 Fernandez et al.
 6,939,373 B2 9/2005 Gomez
 6,955,686 B2 10/2005 Majercak et al.
 6,962,603 B1 11/2005 Brown et al.
 6,979,349 B1 12/2005 Dang et al.
 6,997,946 B2 2/2006 Girton et al.
 6,998,060 B2 2/2006 Tomonto

7,005,136 B2 2/2006 Nathan et al.
 7,025,777 B2 4/2006 Moore
 7,029,493 B2 4/2006 Majercak et al.
 7,044,963 B1 5/2006 Richter
 7,052,498 B2 5/2006 Levy et al.
 7,060,088 B1 6/2006 Fischell et al.
 7,081,130 B2 7/2006 Jang
 7,094,255 B2 8/2006 Penn et al.
 7,101,391 B2 9/2006 Scheuermann et al.
 7,108,714 B1 9/2006 Becker
 7,112,216 B2 9/2006 Gregorich
 7,670,339 B2 3/2010 Levy et al.
 2001/0020181 A1 9/2001 Layne
 2002/0032444 A1* 3/2002 Mische 606/63
 2002/0165544 A1 11/2002 Perren et al.
 2003/0109932 A1* 6/2003 Keynan 623/23.18
 2004/0199246 A1* 10/2004 Chu et al. 623/1.32
 2004/0230193 A1 11/2004 Cheung et al.
 2005/0216007 A1 9/2005 Woll et al.
 2006/0264945 A1* 11/2006 Edidin et al. 606/63
 2006/0264950 A1 11/2006 Nelson et al.
 2006/0264951 A1 11/2006 Nelson et al.
 2006/0264952 A1 11/2006 Nelson et al.
 2007/0213725 A1 9/2007 Hack
 2007/0233105 A1 10/2007 Nelson et al.
 2008/0033522 A1* 2/2008 Grewe et al. 623/1.11
 2008/0169582 A1 7/2008 Dave et al.
 2008/0228186 A1 9/2008 Gall et al.
 2008/0255560 A1* 10/2008 Myers et al. 606/63
 2008/0269745 A1 10/2008 Justin
 2008/0269746 A1 10/2008 Justin
 2008/0269748 A1 10/2008 Justin et al.
 2008/0269749 A1 10/2008 Justin et al.
 2008/0269750 A1 10/2008 Justin
 2008/0269776 A1 10/2008 Justin et al.
 2009/0005782 A1 1/2009 Chirico et al.

FOREIGN PATENT DOCUMENTS

WO WO9838918 9/1998
 WO WO 00/12832 3/2000
 WO WO03065913 8/2003
 WO WO2005/112804 12/2005
 WO PCT/US08/61047 4/2008
 WO WO 2008/134287 11/2008

OTHER PUBLICATIONS

International Preliminary Report on Patentability in PCT/US2008/061047 dated Oct. 27, 2009 in 9 pages.
 Miller et al., "Performance Evaluation of a Cement-Augmented Intramedullary Fixation System for Pathologic Lesions of the Femoral Shaft", Clinical Orthopaedics and Related Research, No. 221, Aug. 1987, p. 246-254.

* cited by examiner

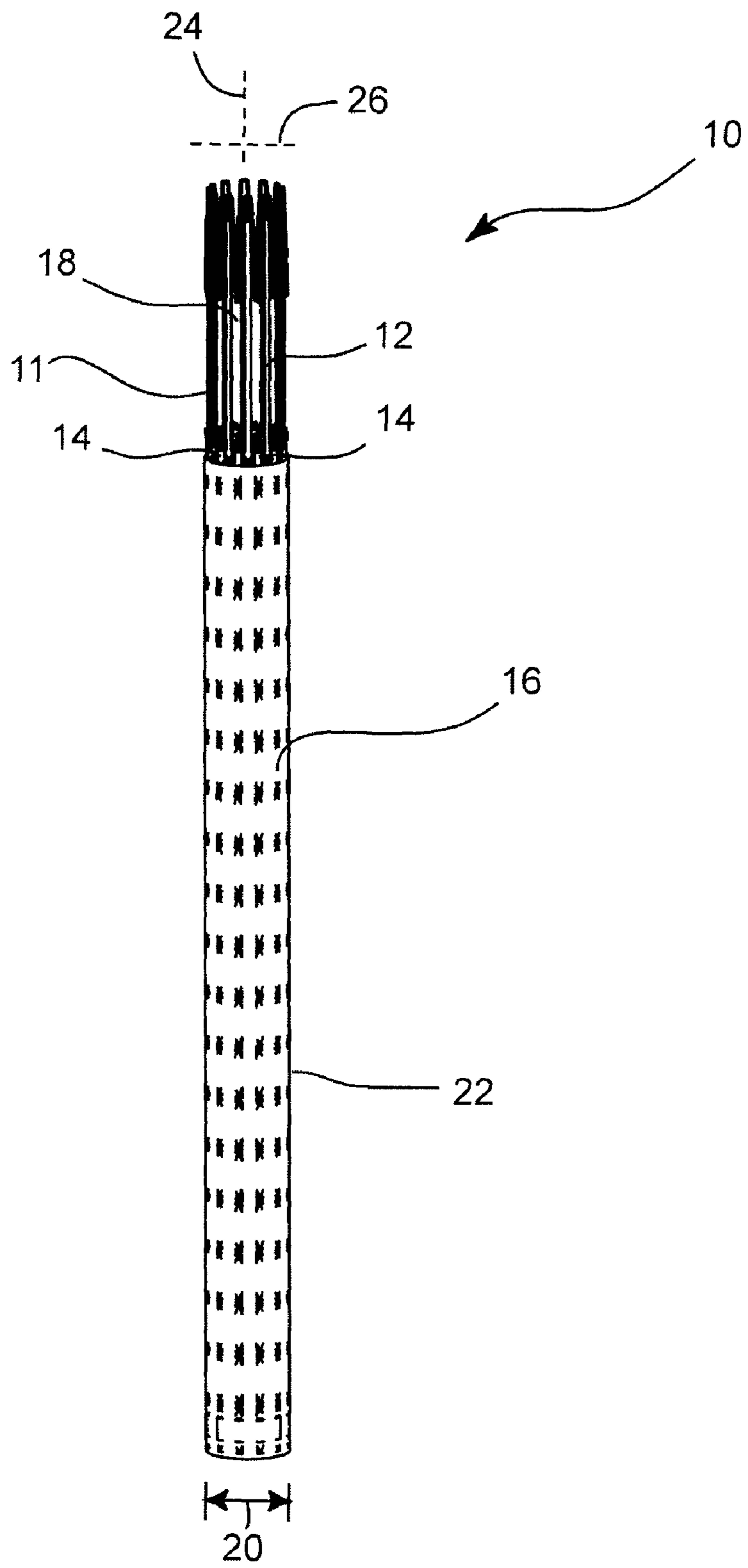

Fig. 1

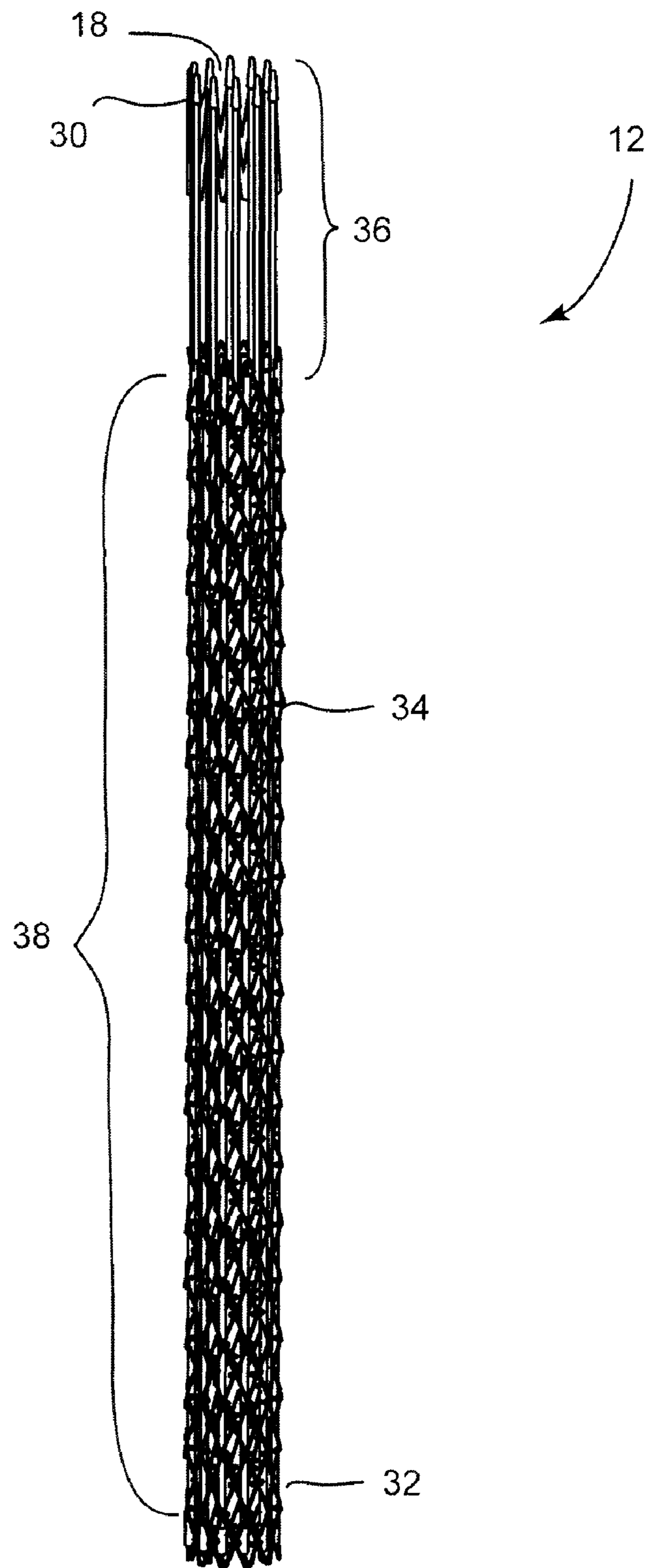

Fig. 2

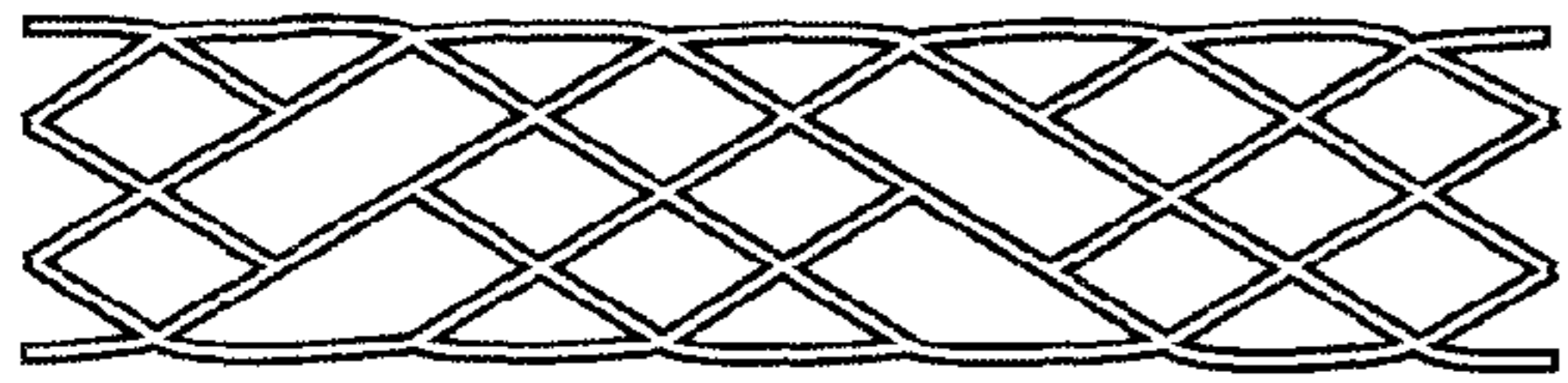

Fig. 3A

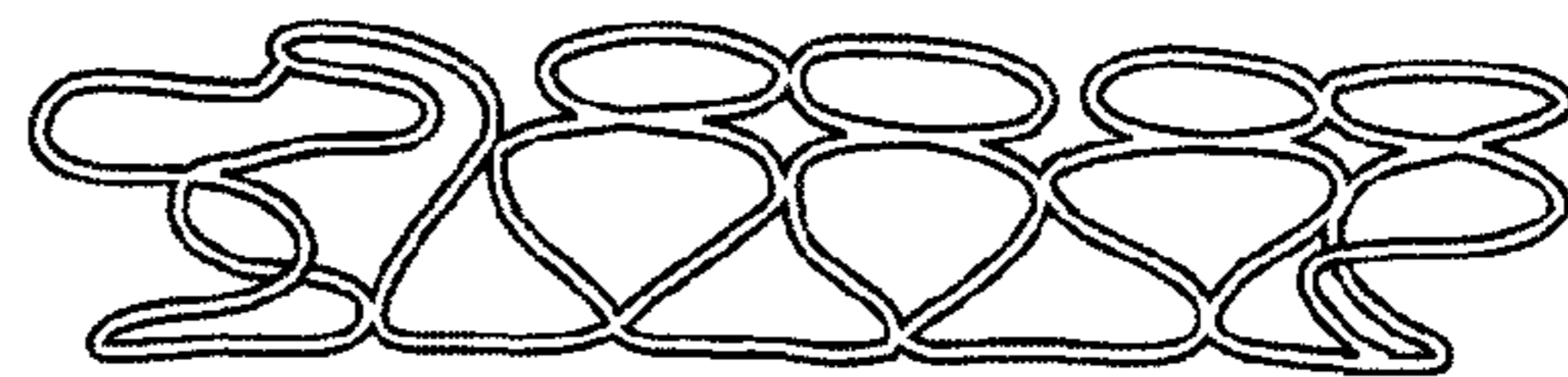

Fig. 3B

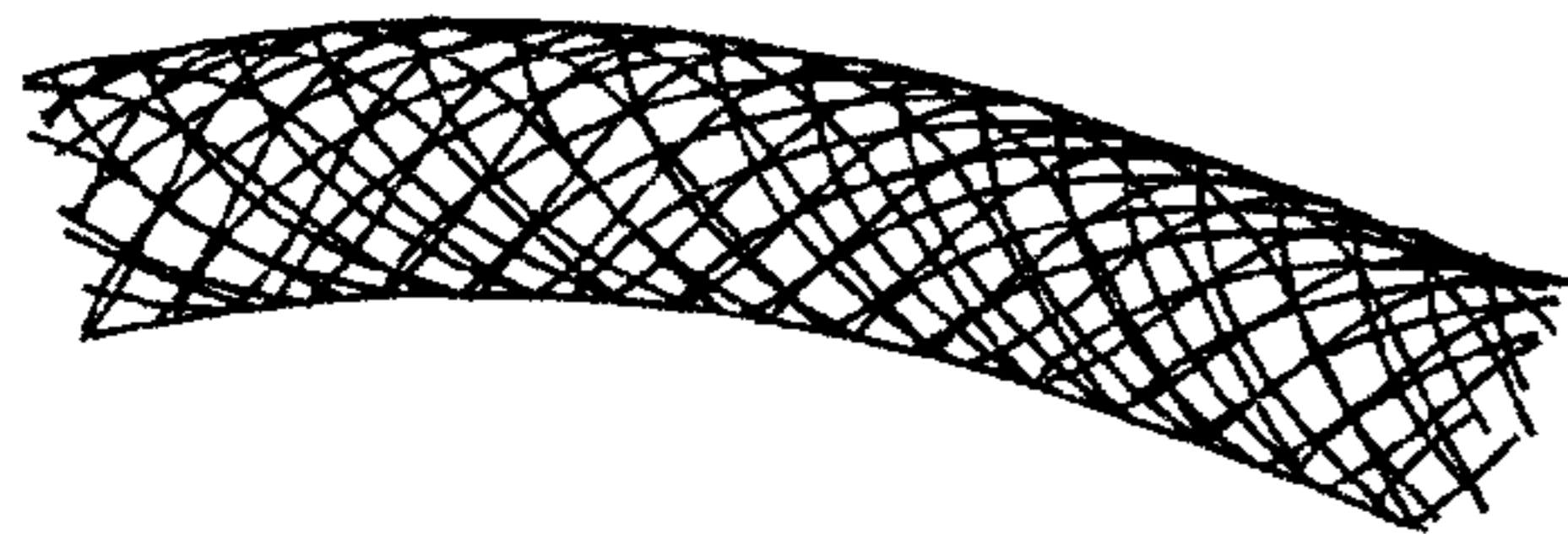

Fig. 3C

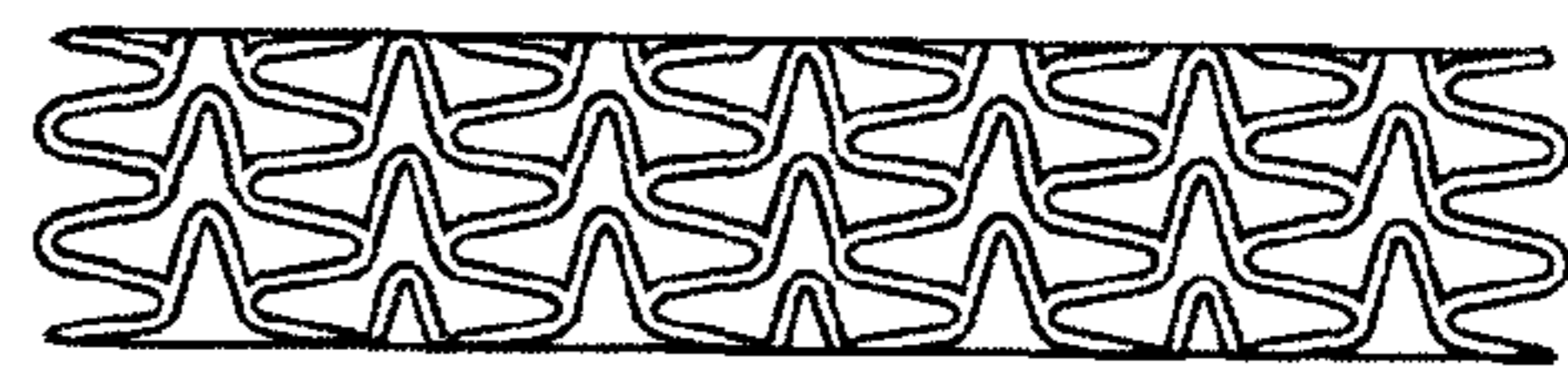

Fig. 3D

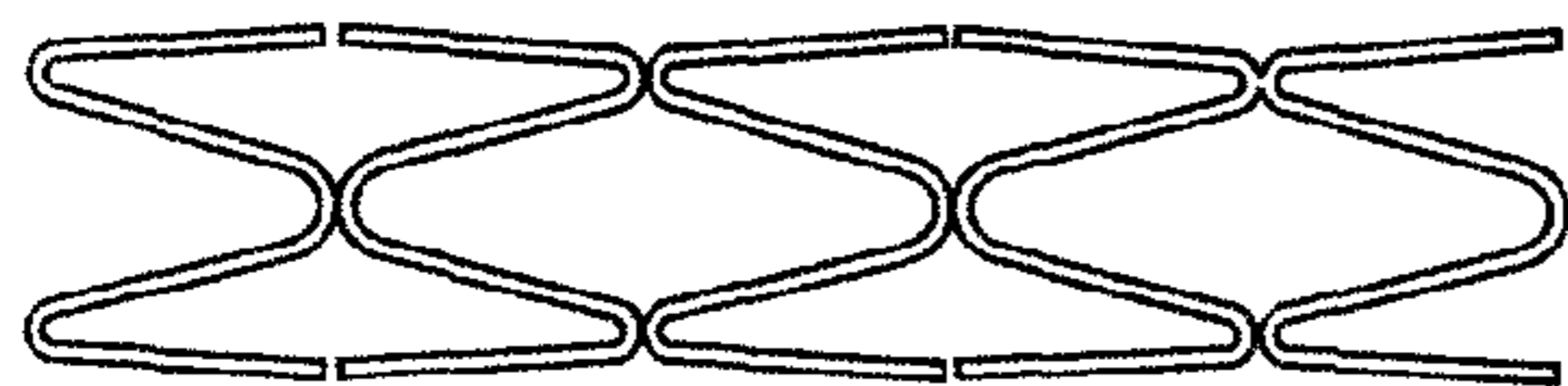

Fig. 3E

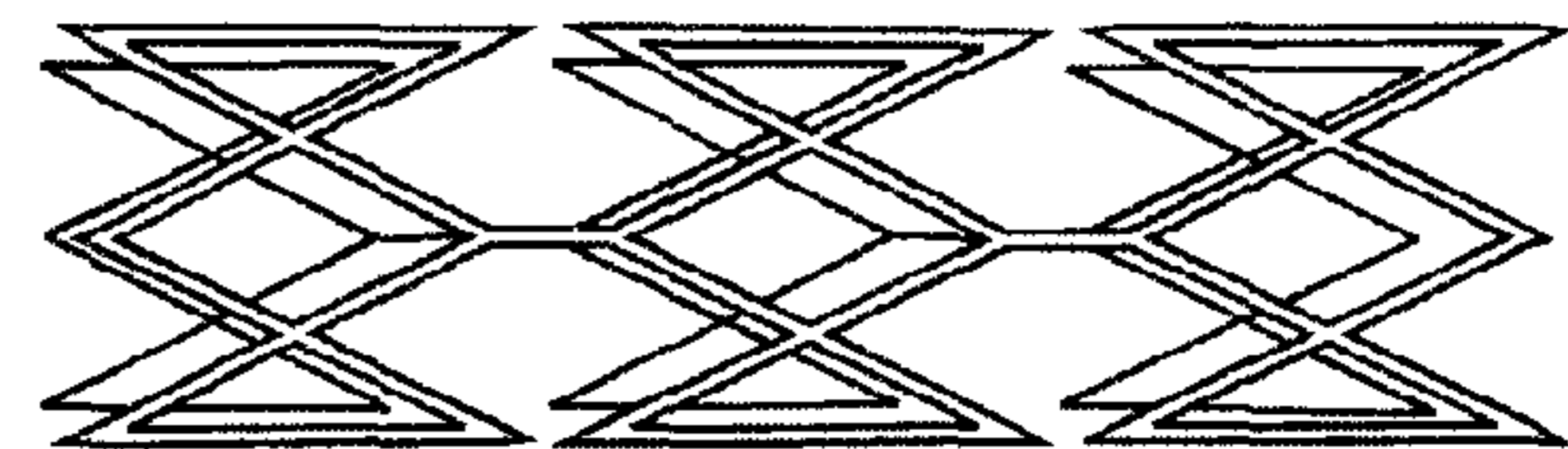

Fig. 3F

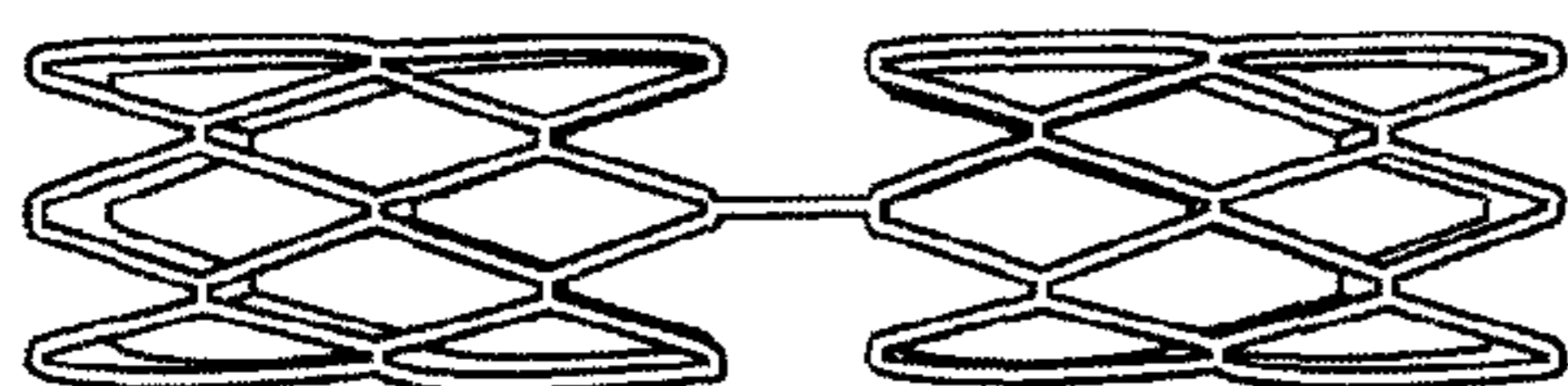

Fig. 3G

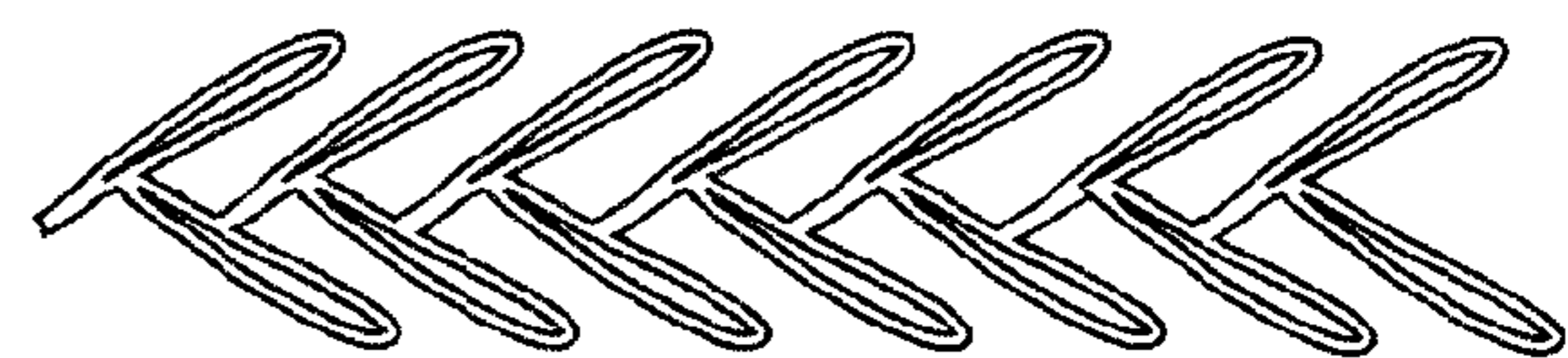

Fig. 3H

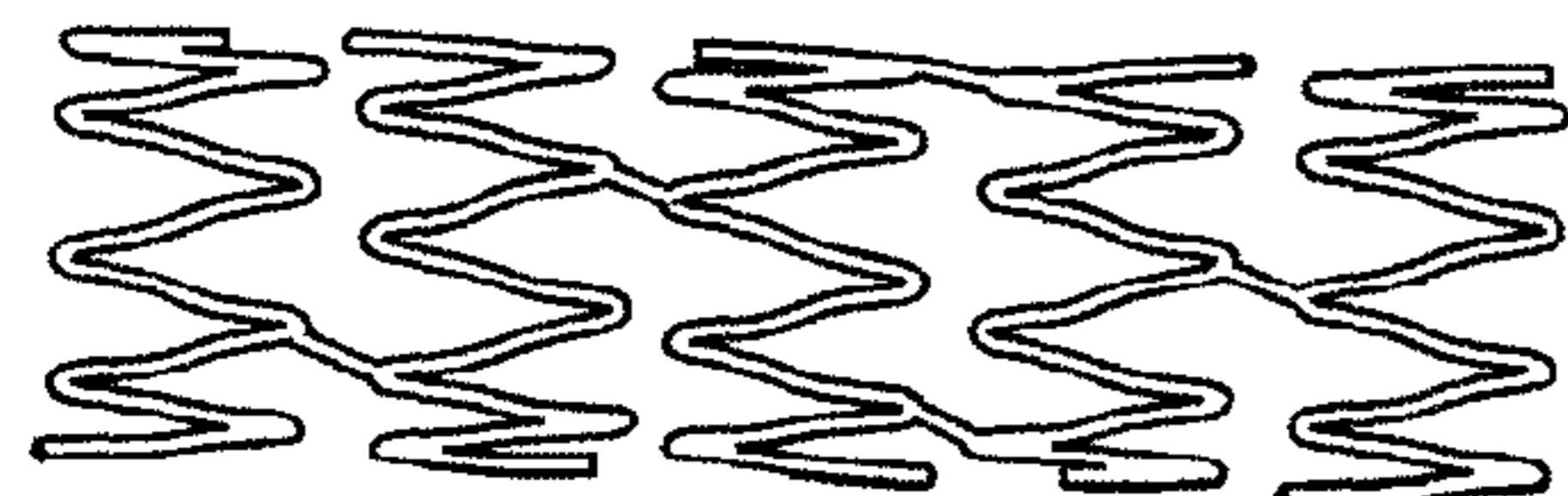

Fig. 3I

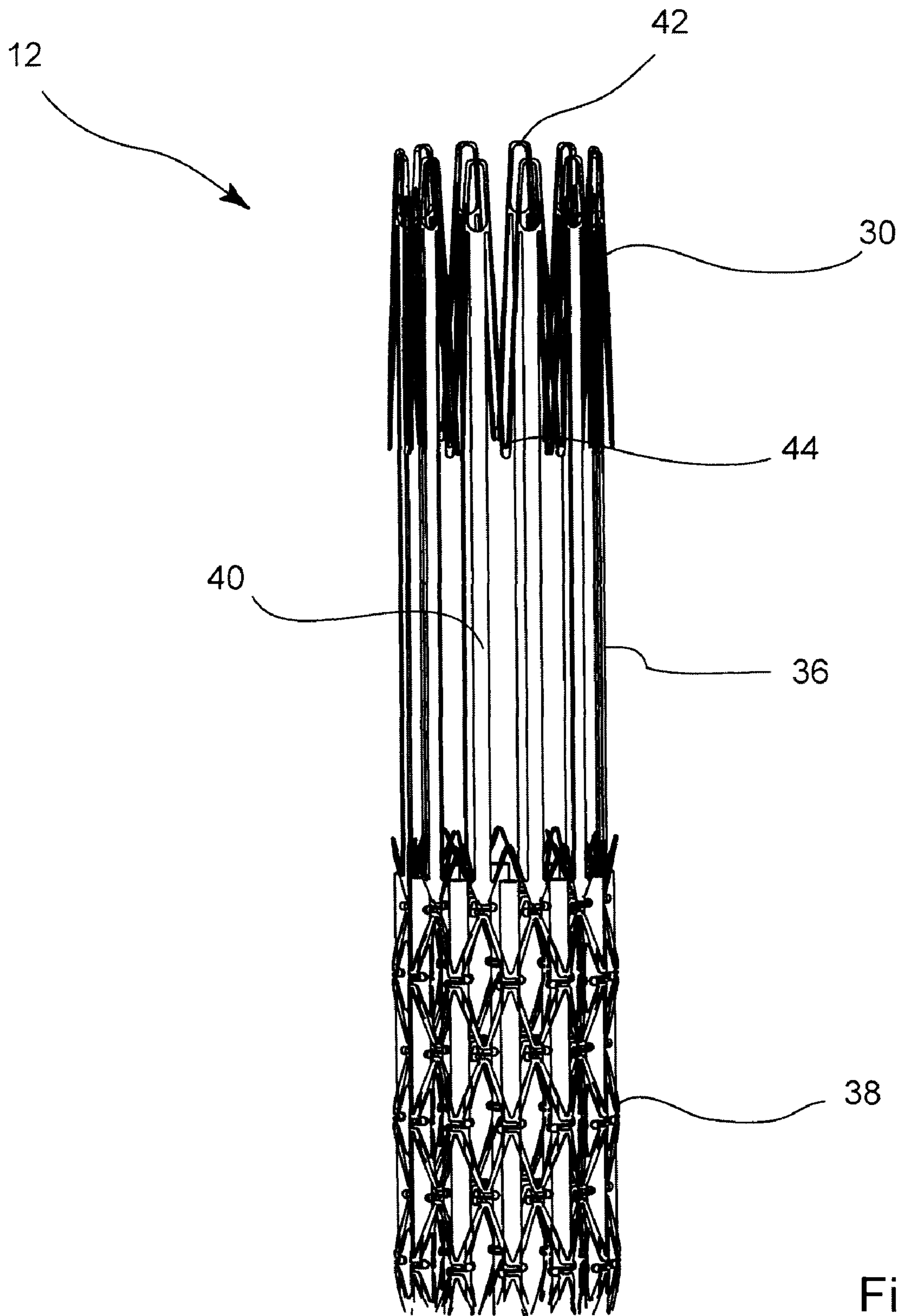

Fig. 4

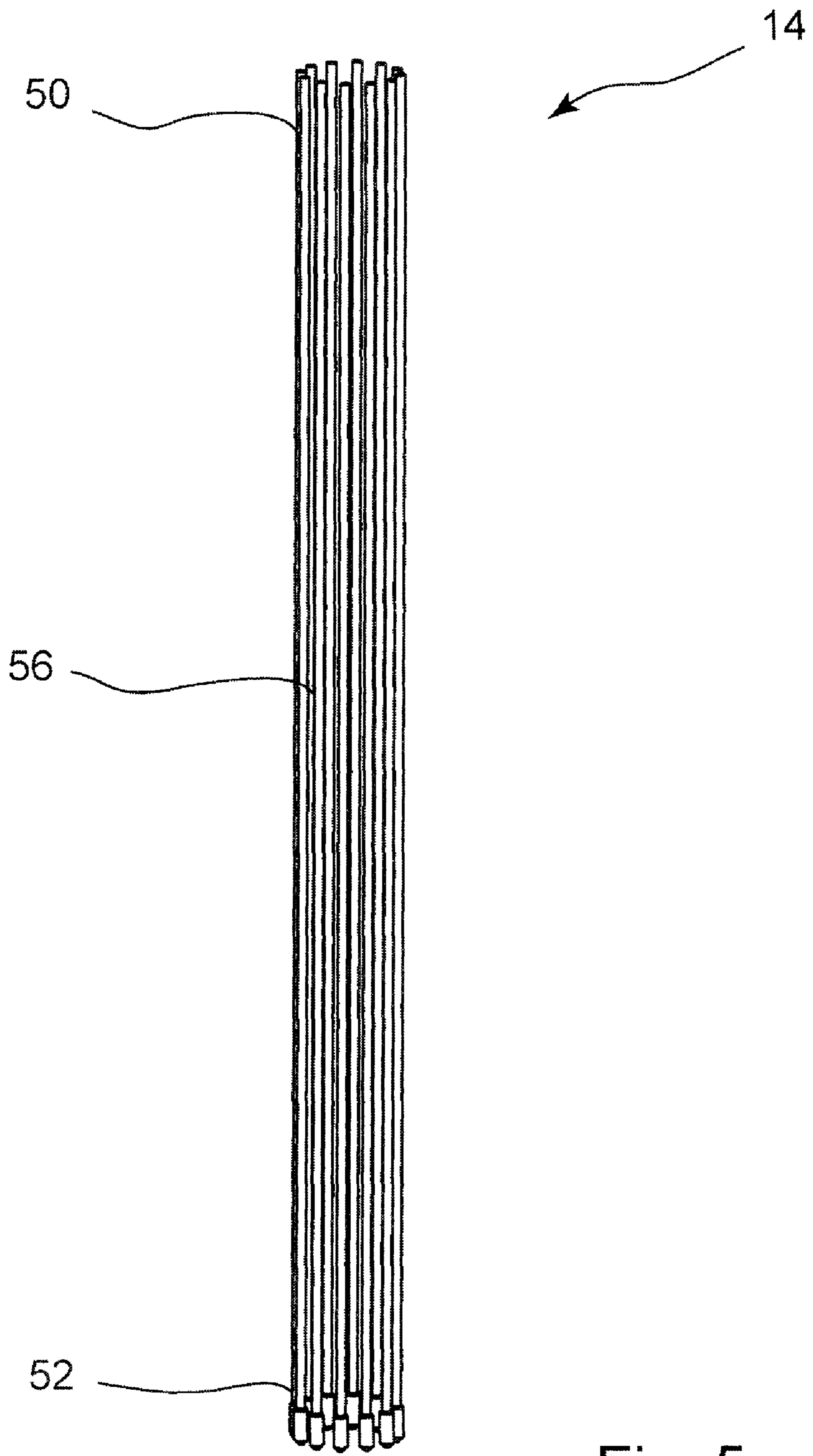

Fig. 5

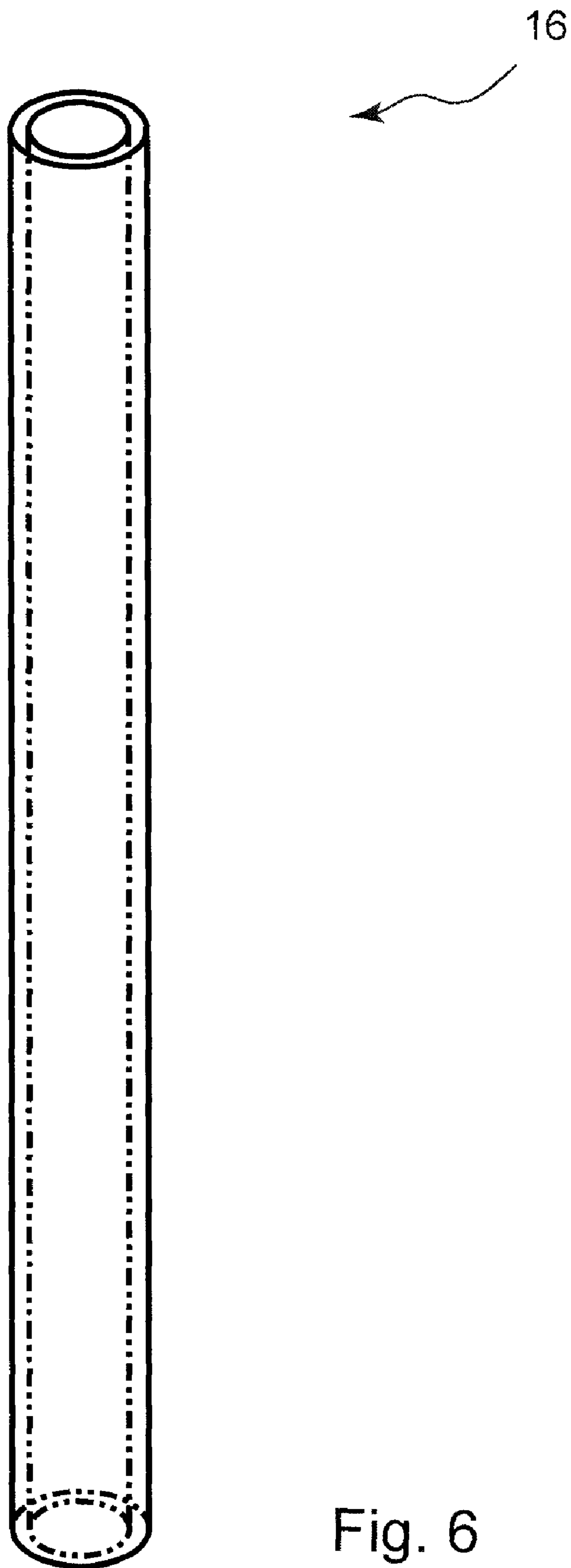

Fig. 6

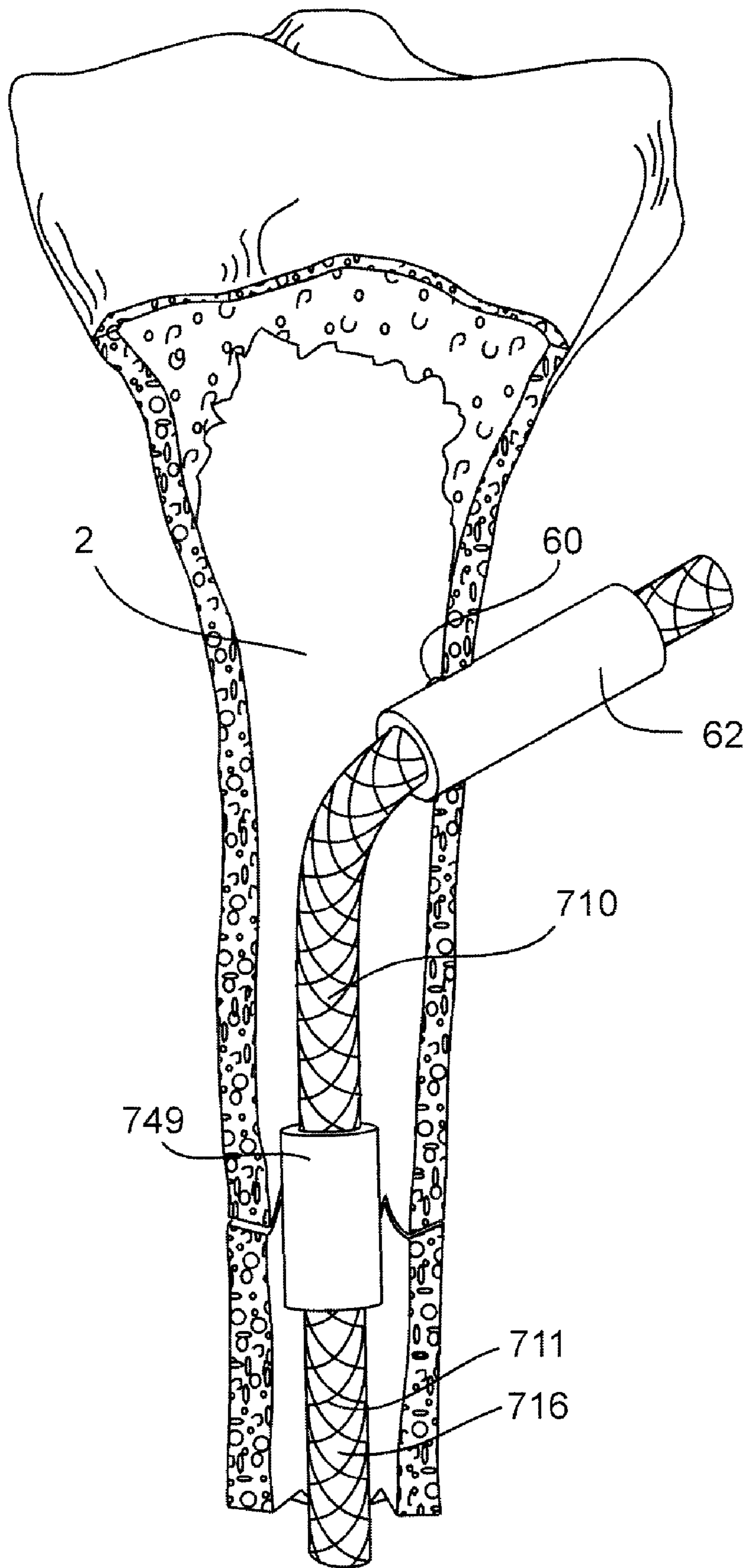

Fig. 7

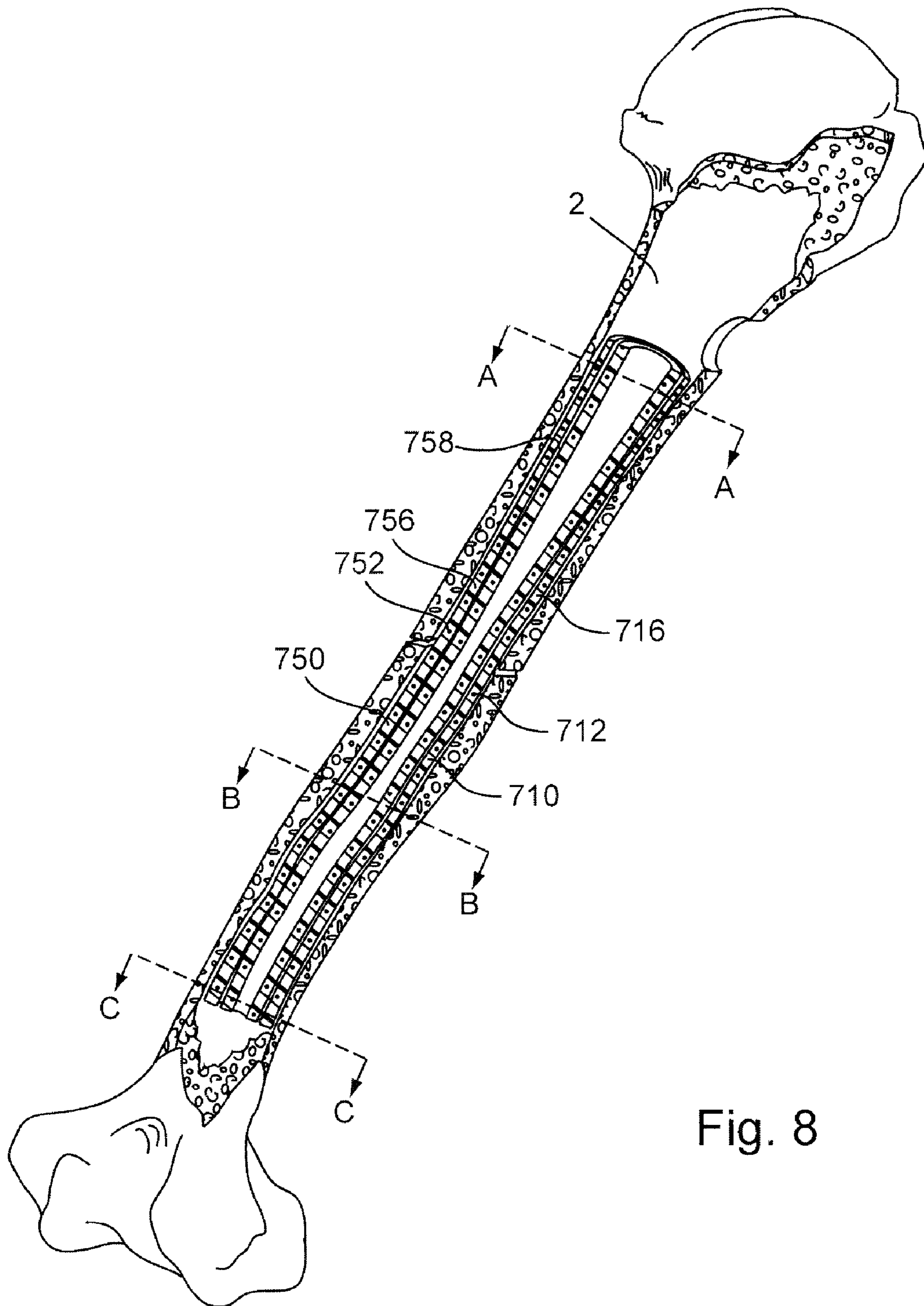
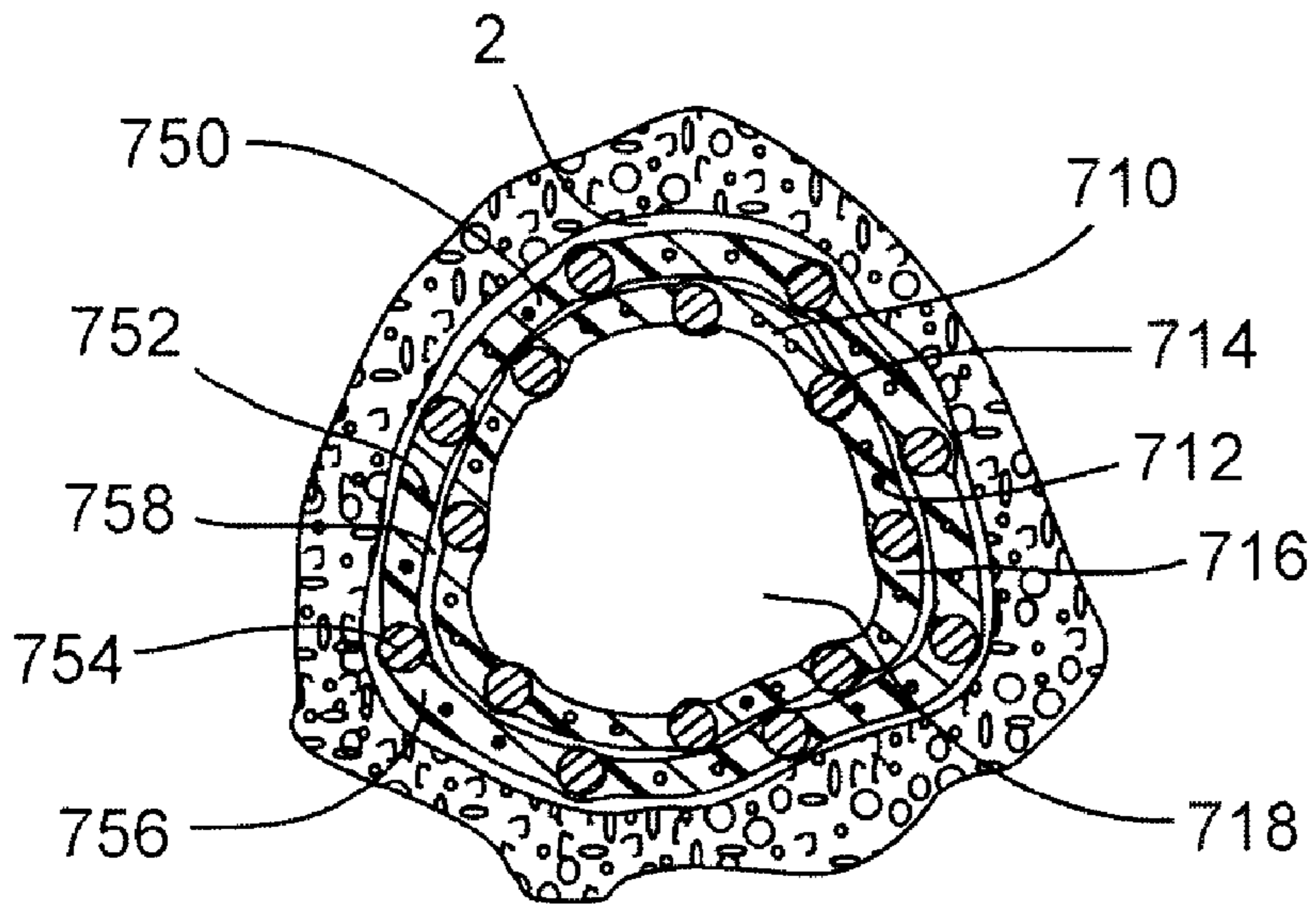
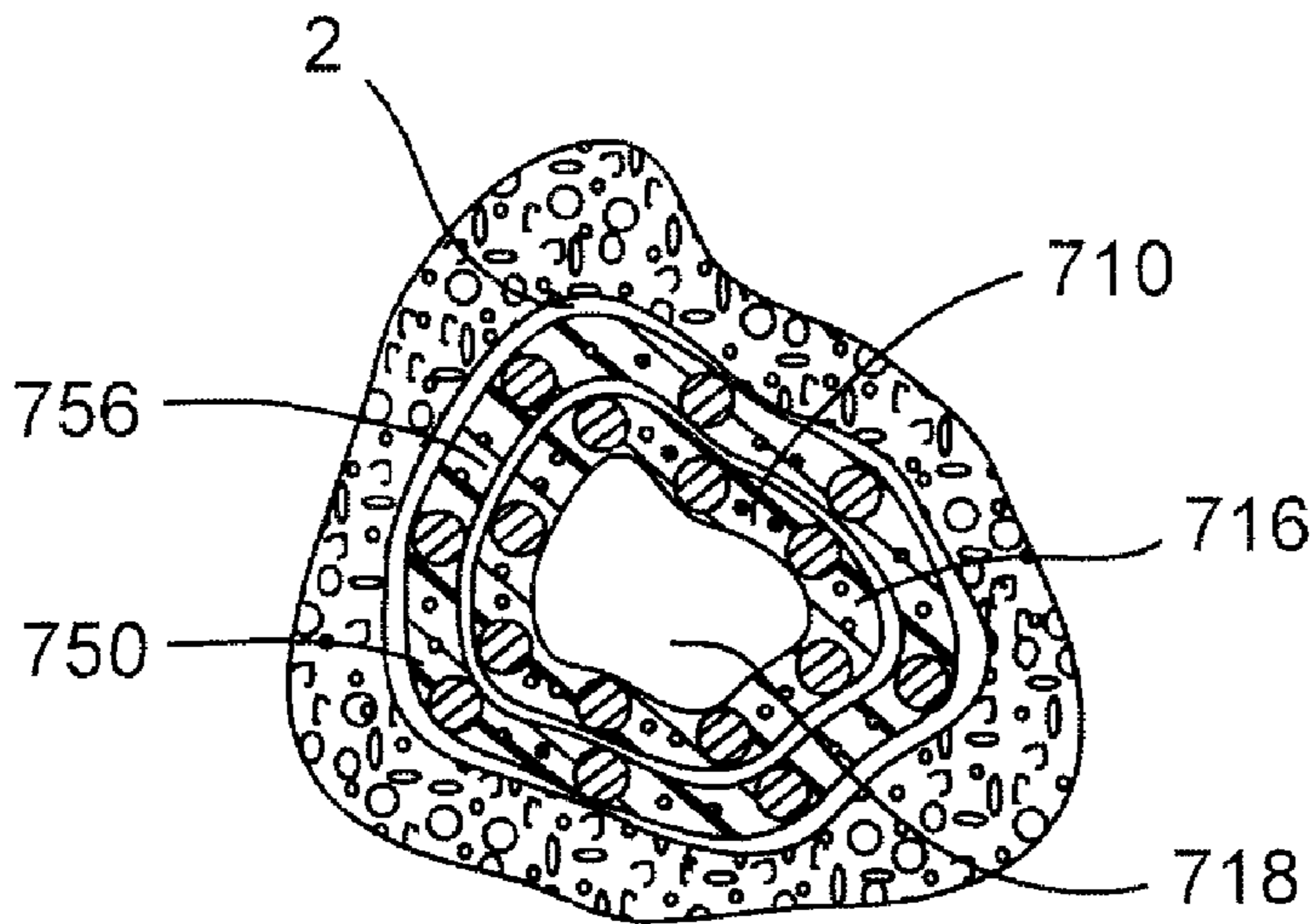

Fig. 8



A-A

Fig. 9A



B-B

Fig. 9B

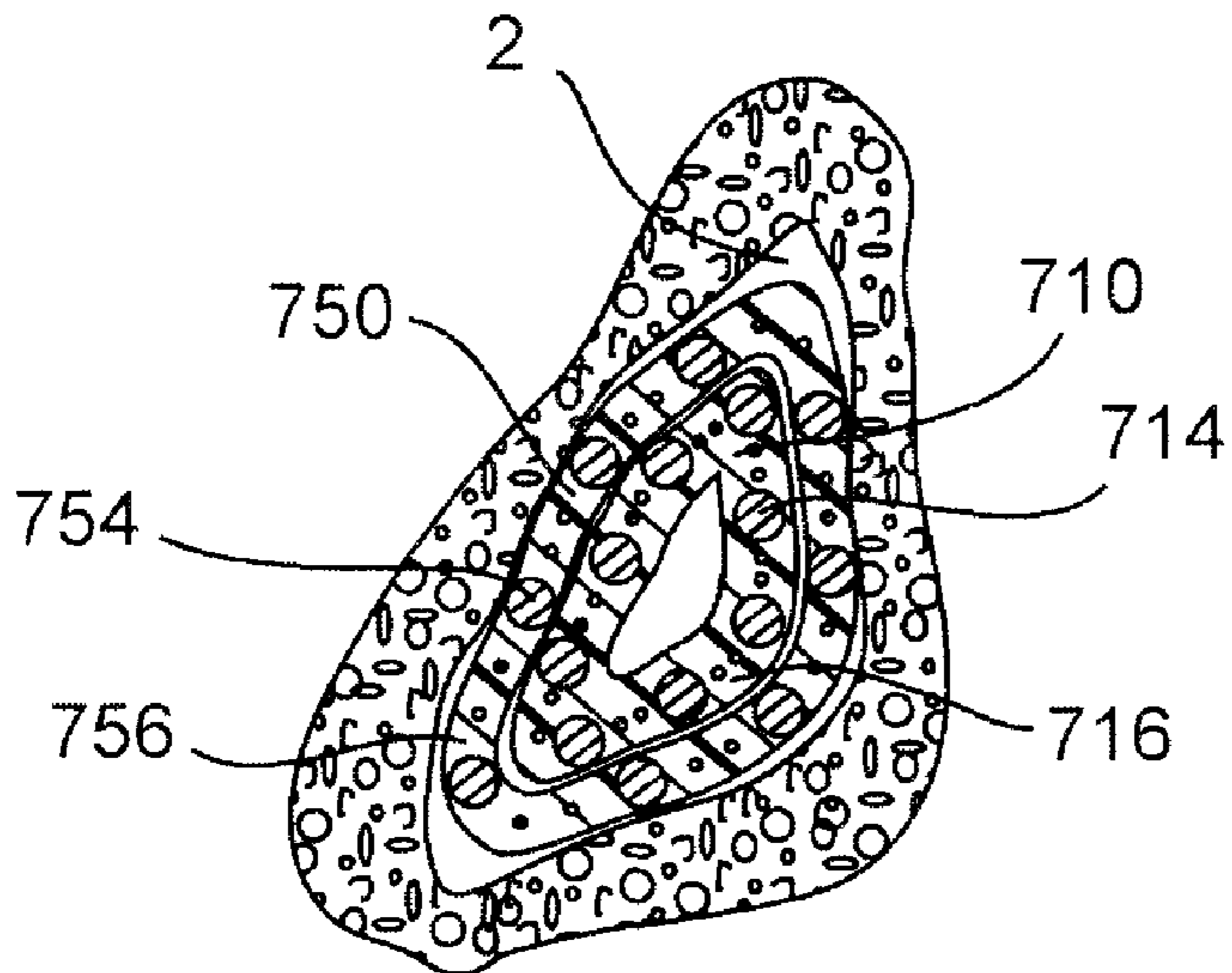

C-C

Fig. 9C

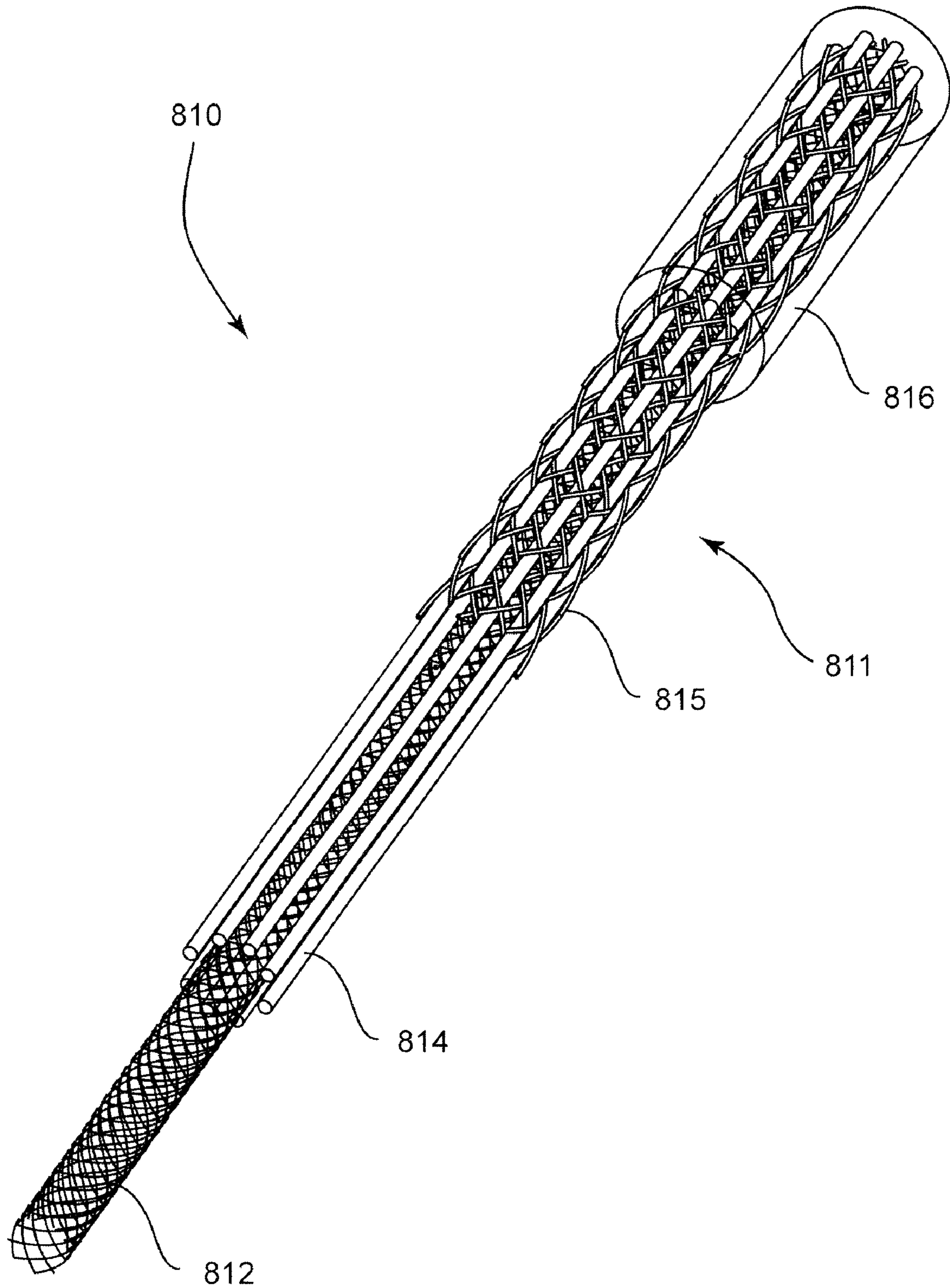

Fig. 10

Fig. 11E

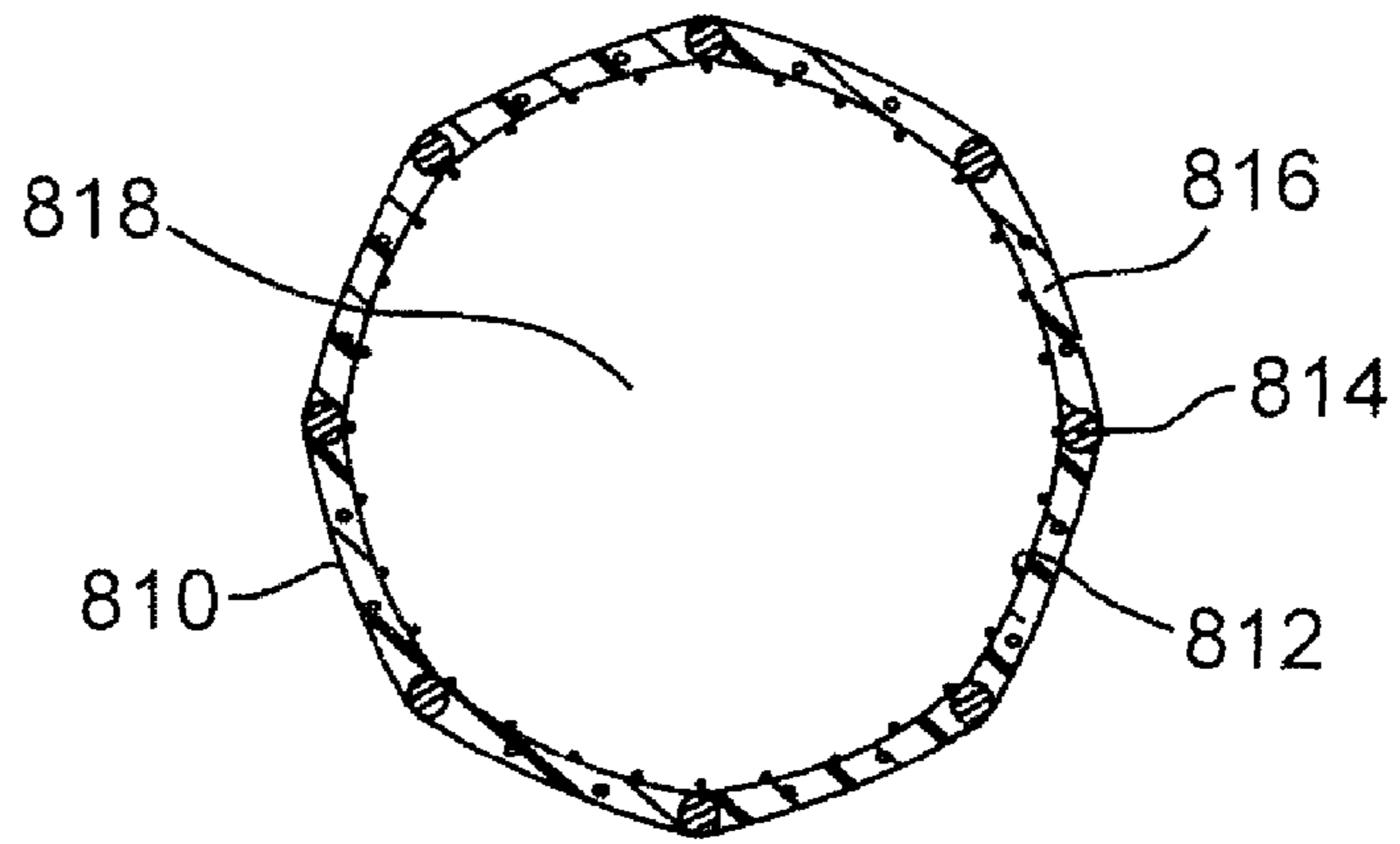

Fig. 11D

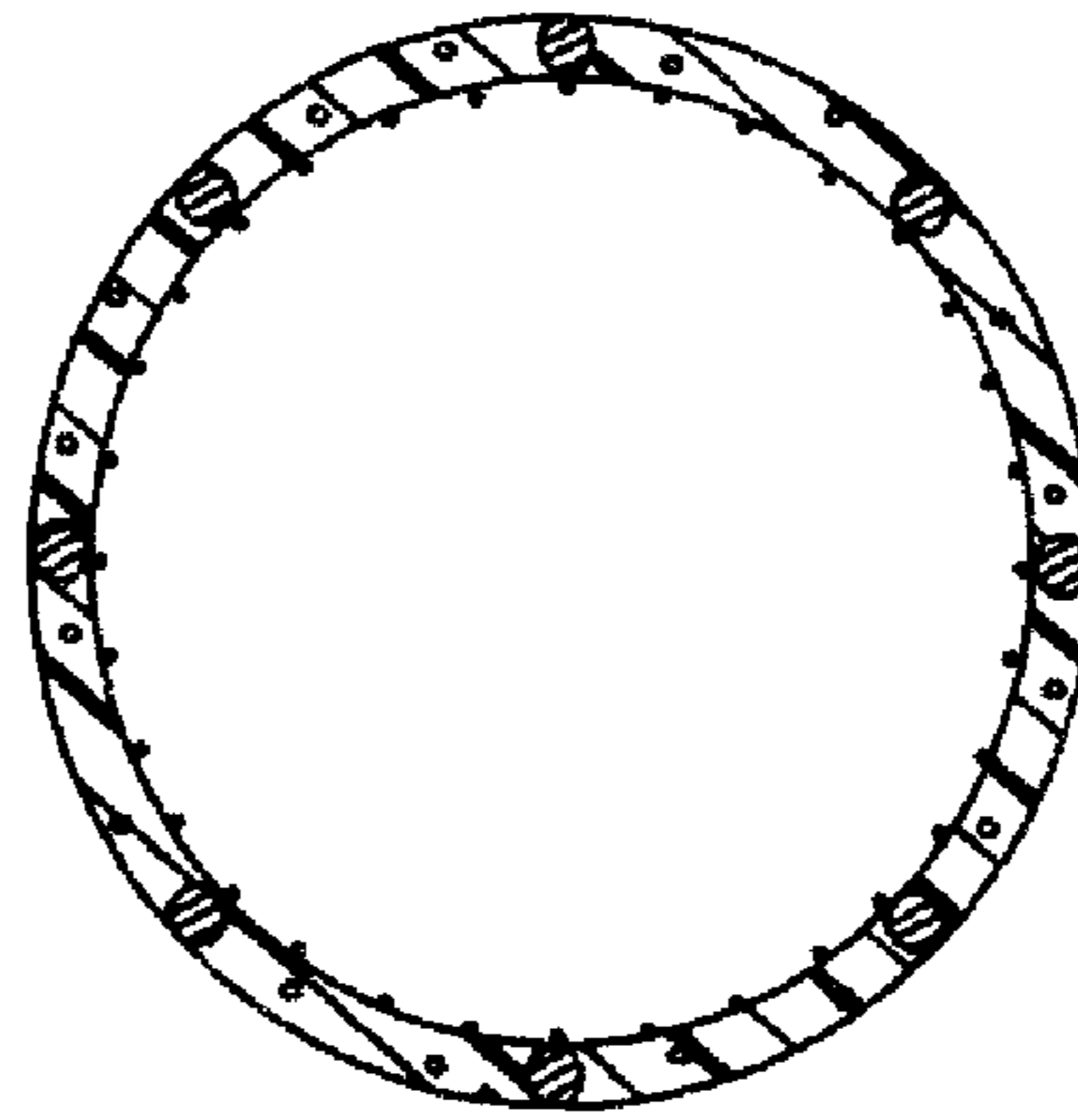

Fig. 11C

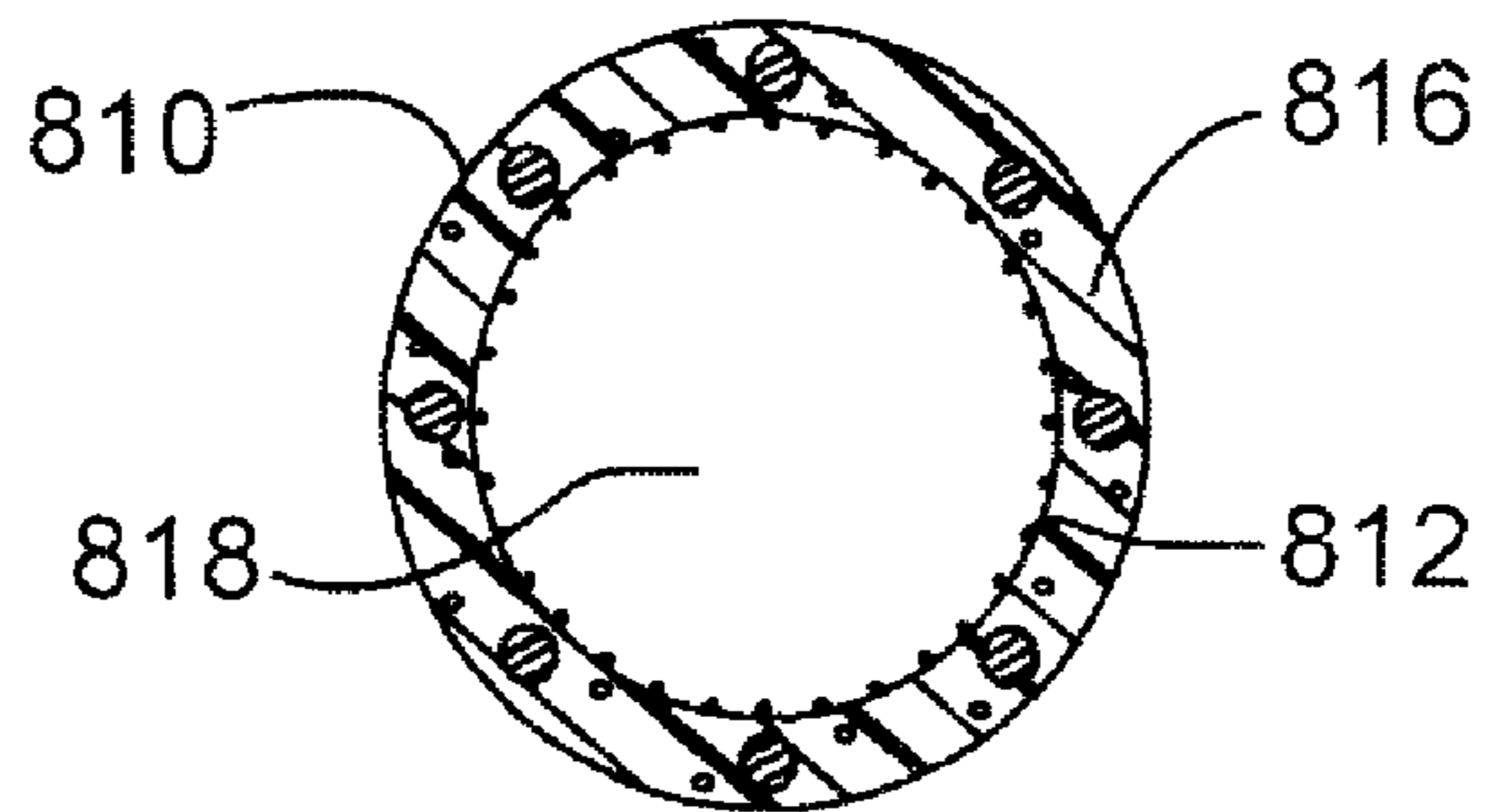

Fig. 11B

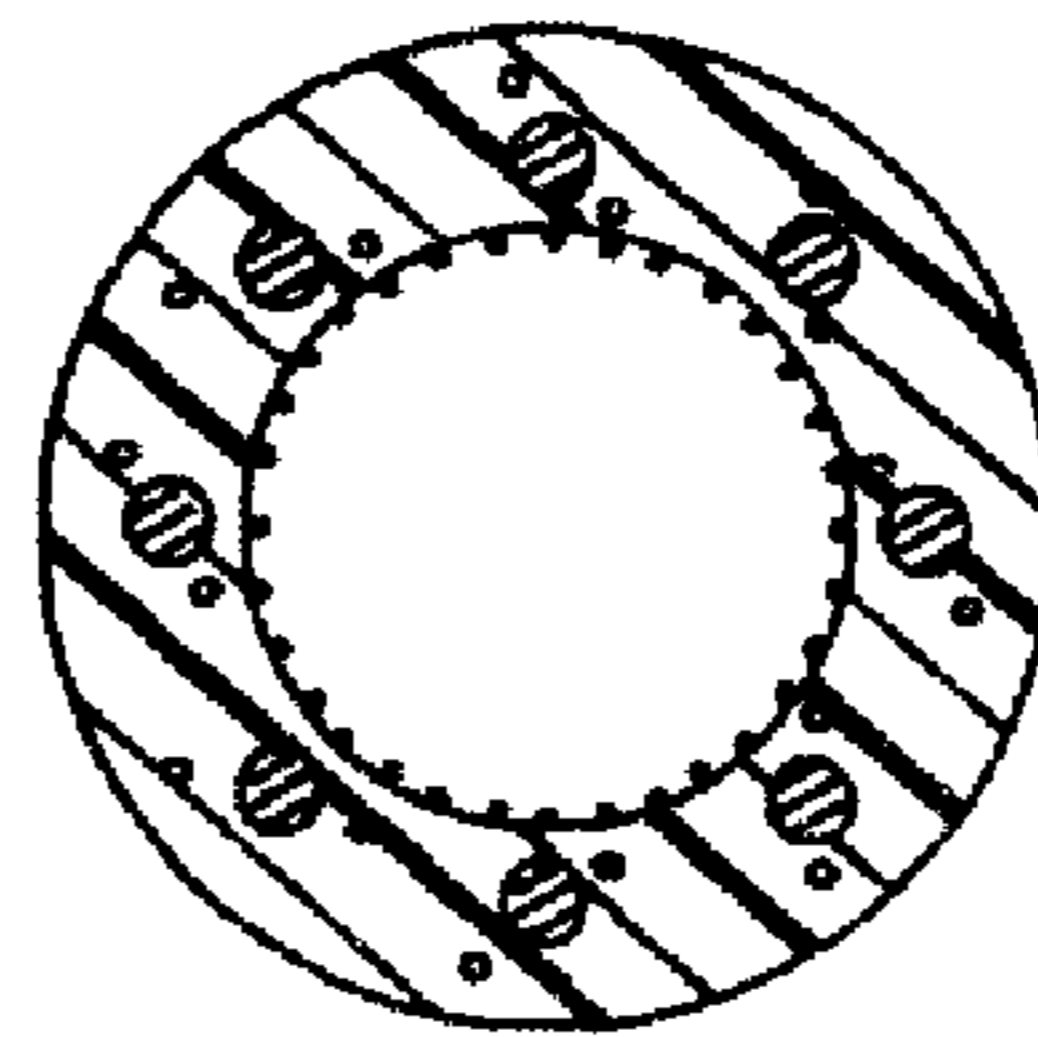

Fig. 11A

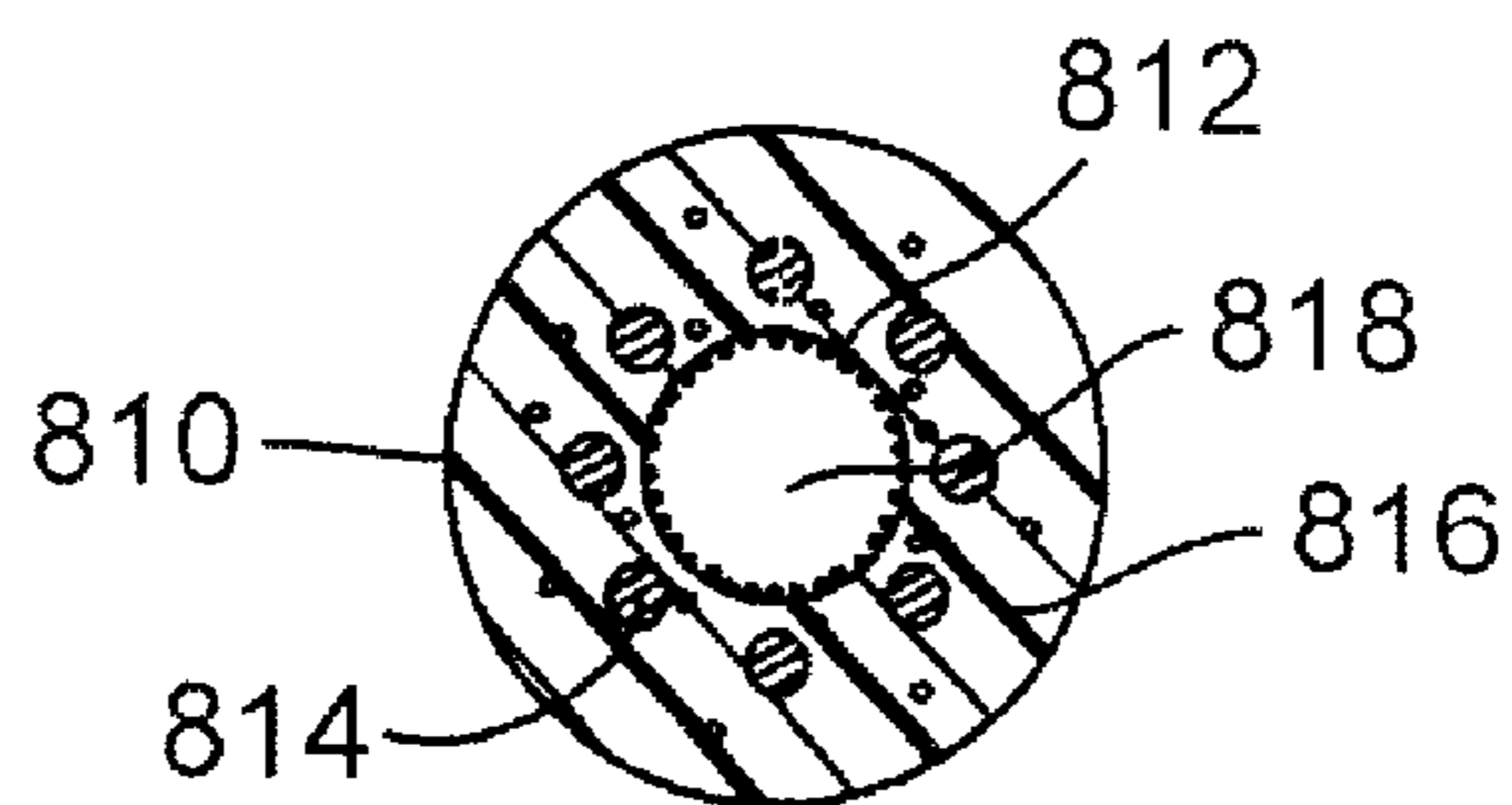

Fig. 12E

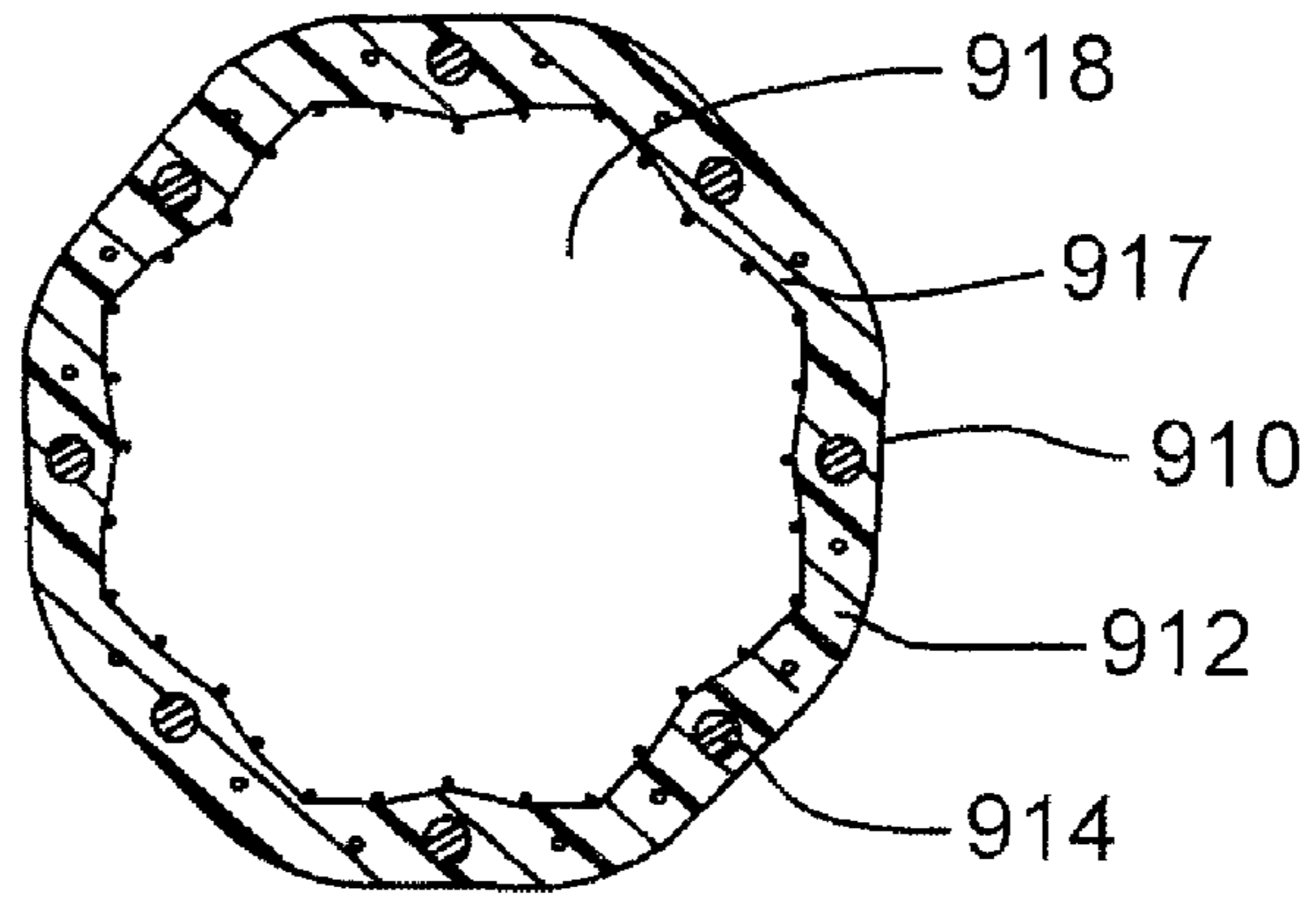

Fig. 12D

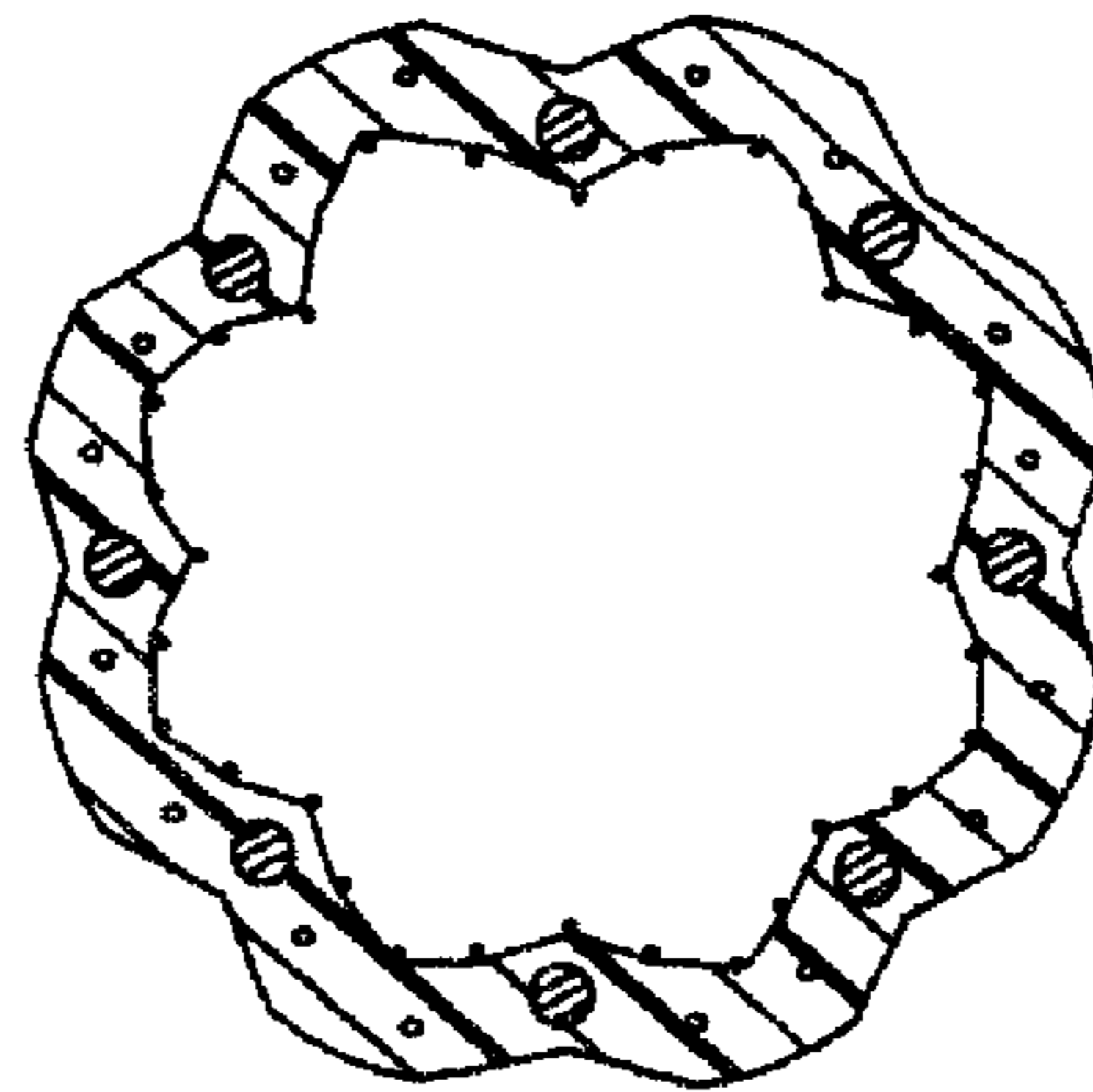

Fig. 12C

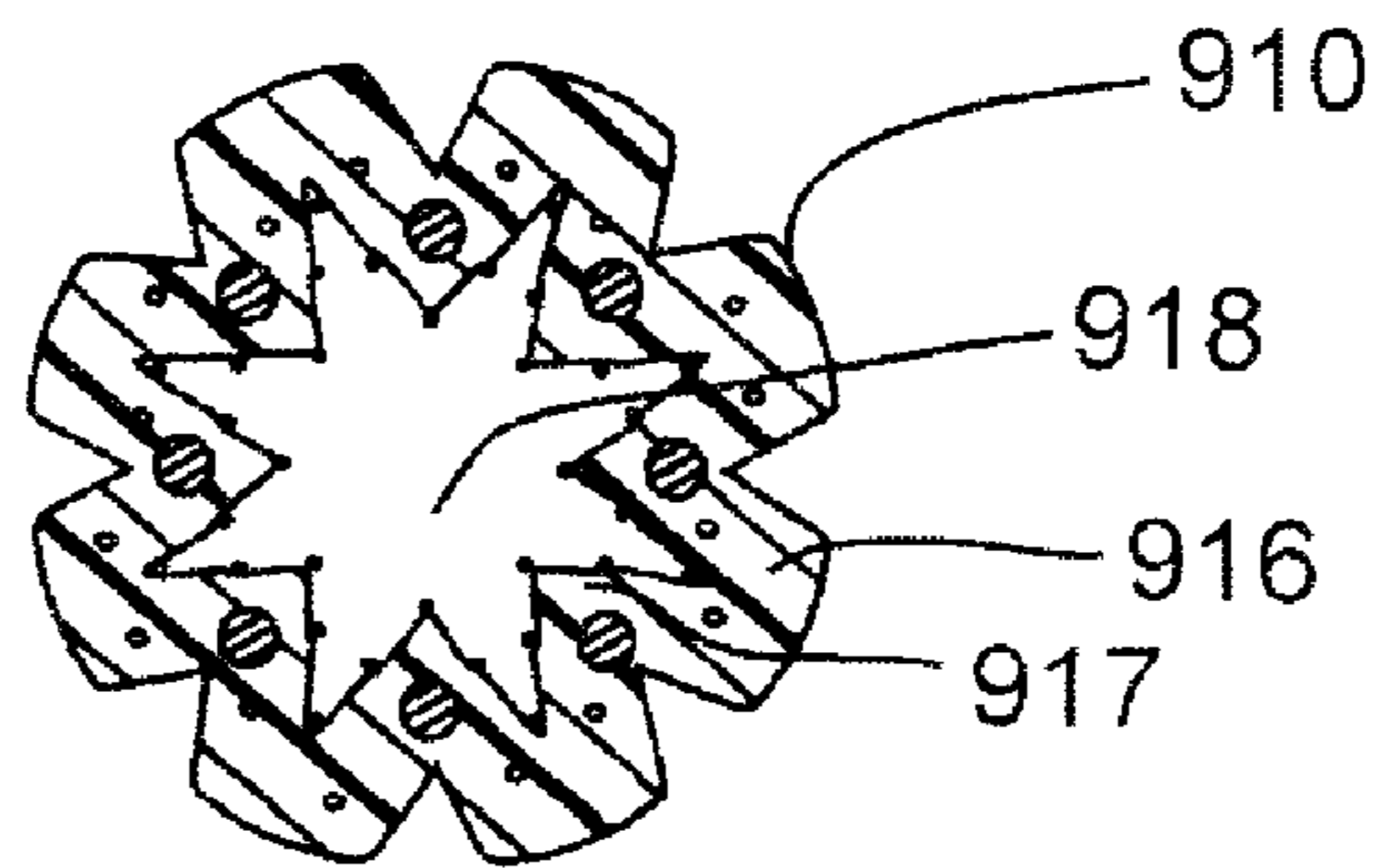

Fig. 12B

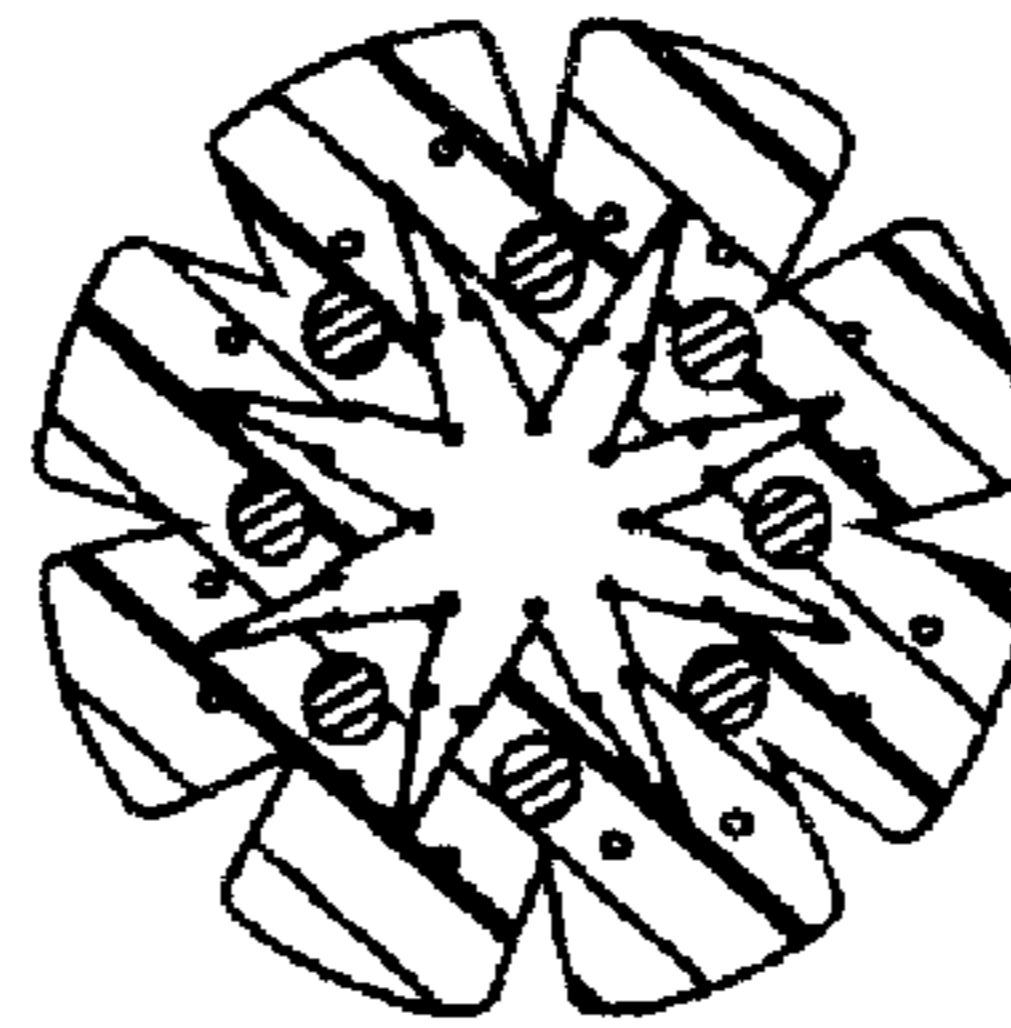
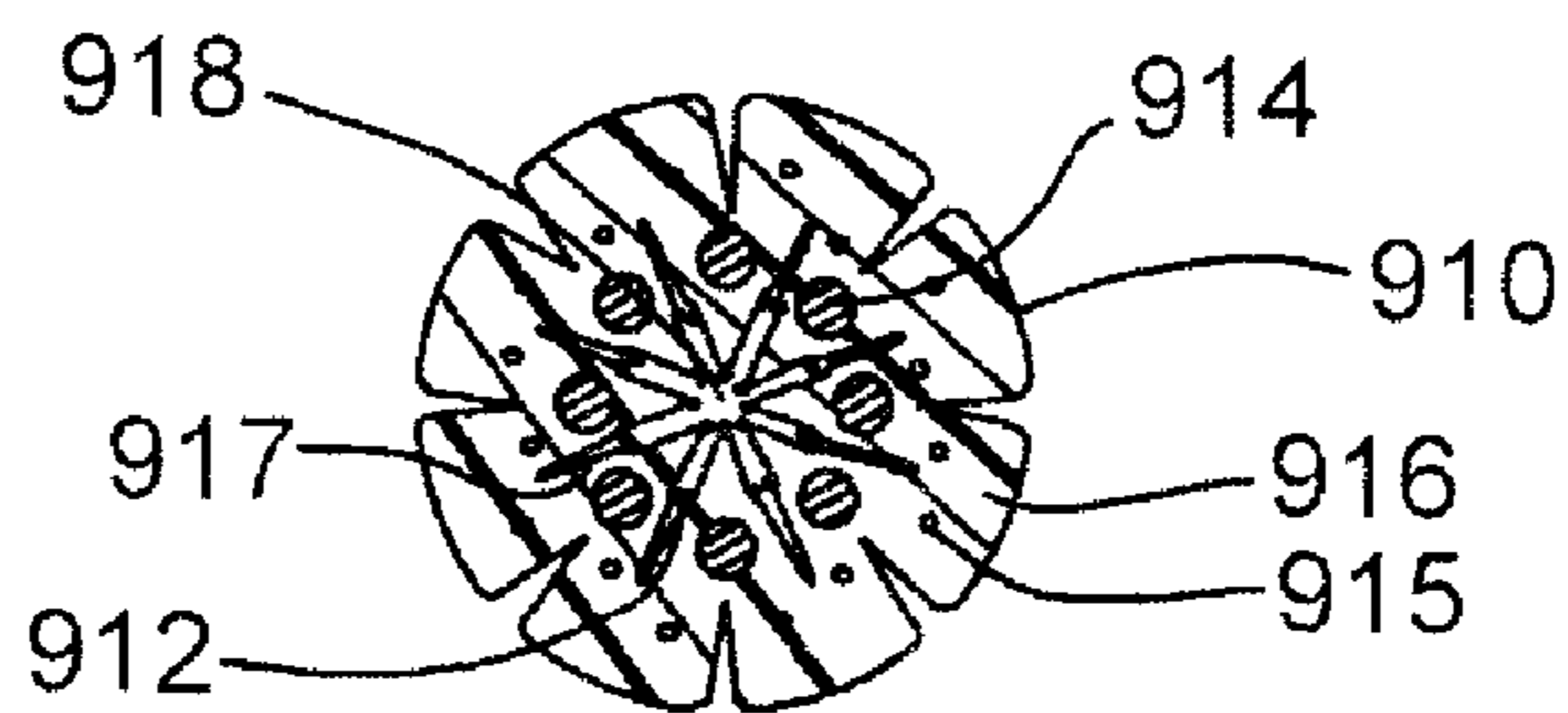

Fig. 12A



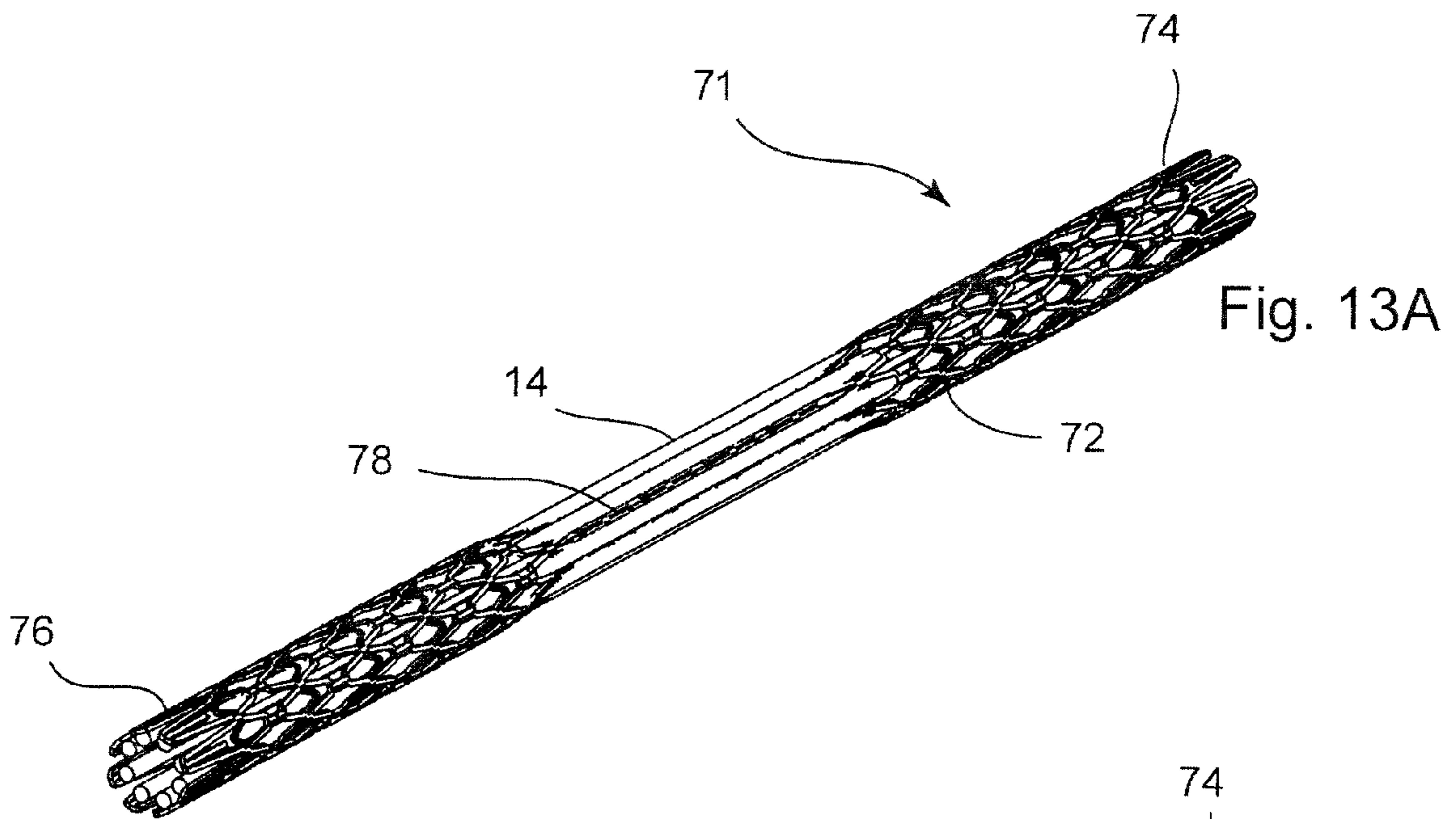

Fig. 13A

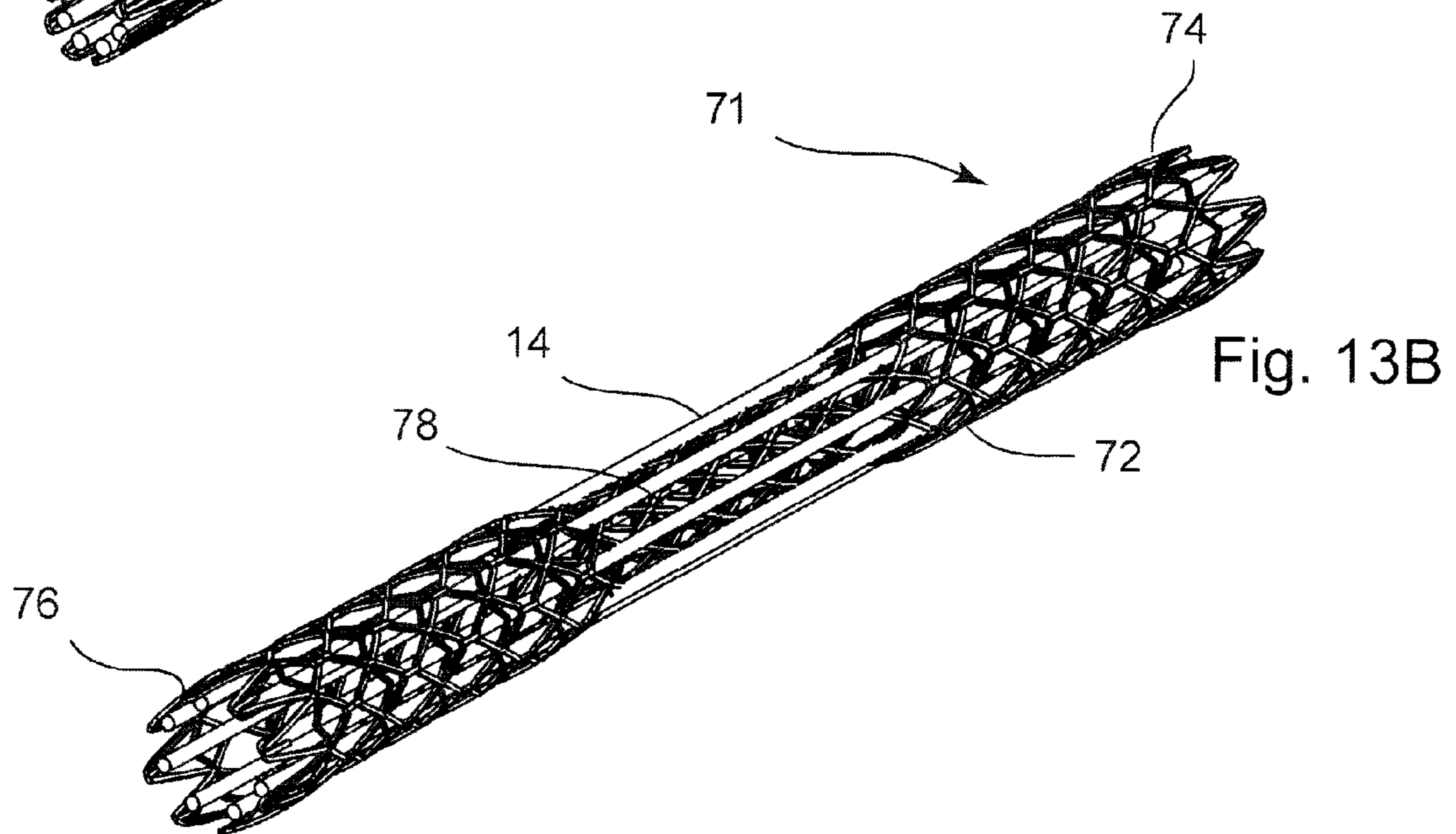
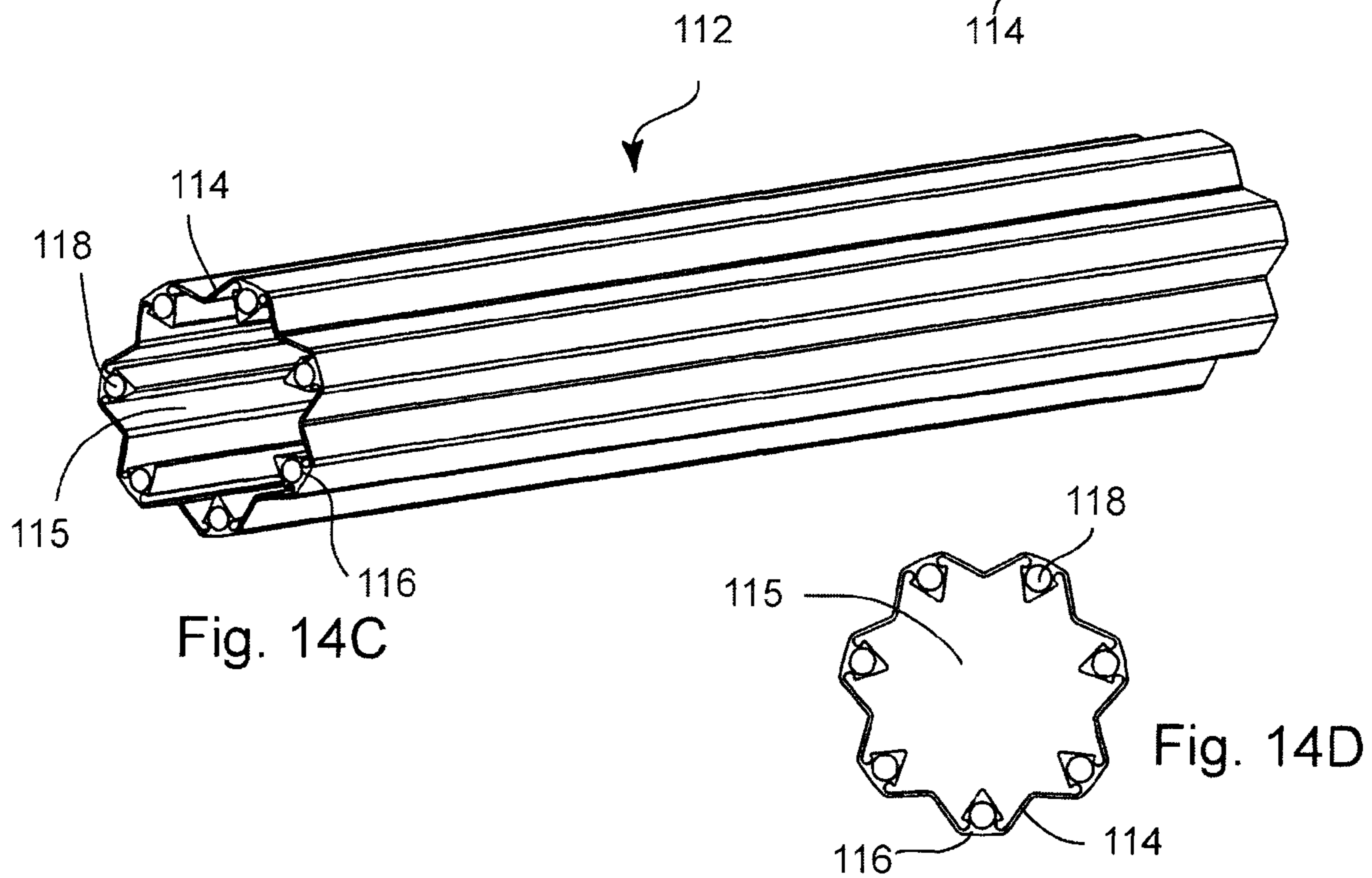
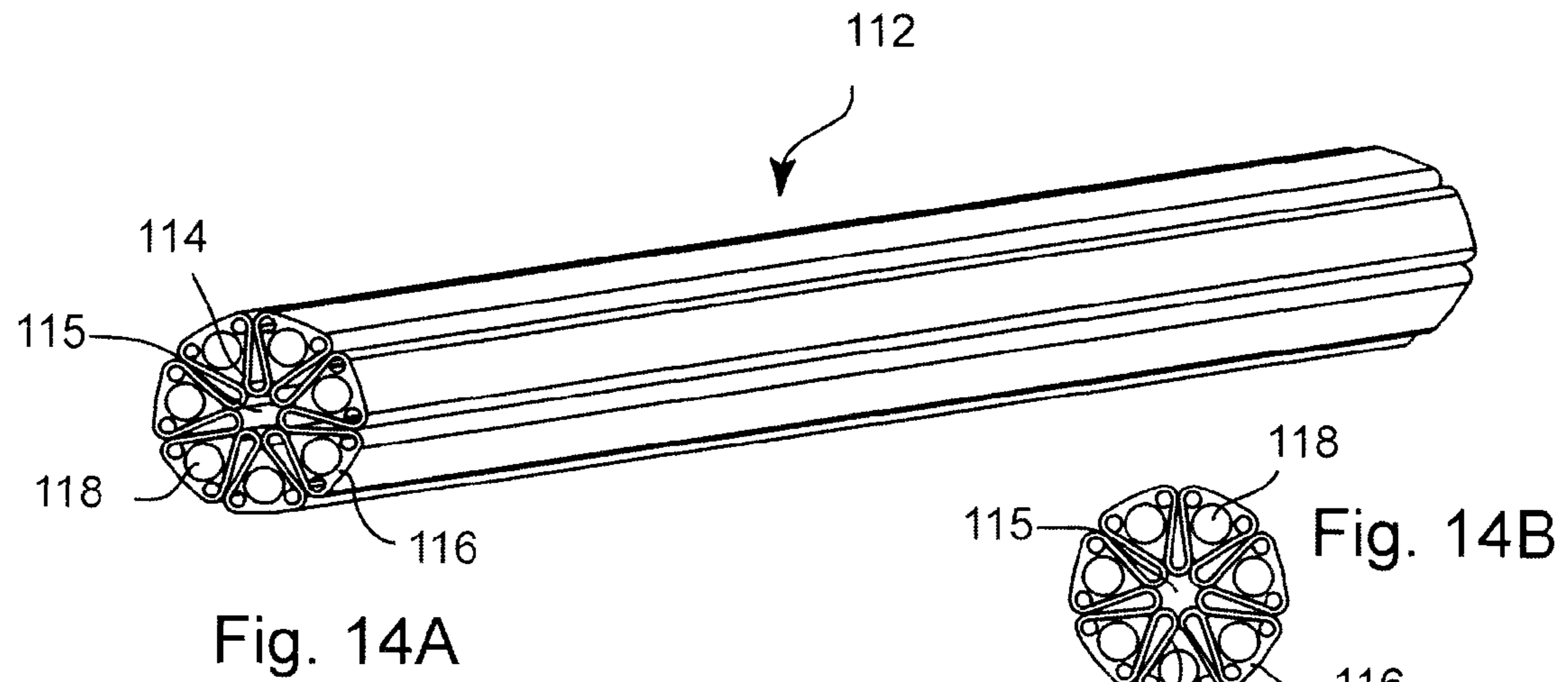

Fig. 13B



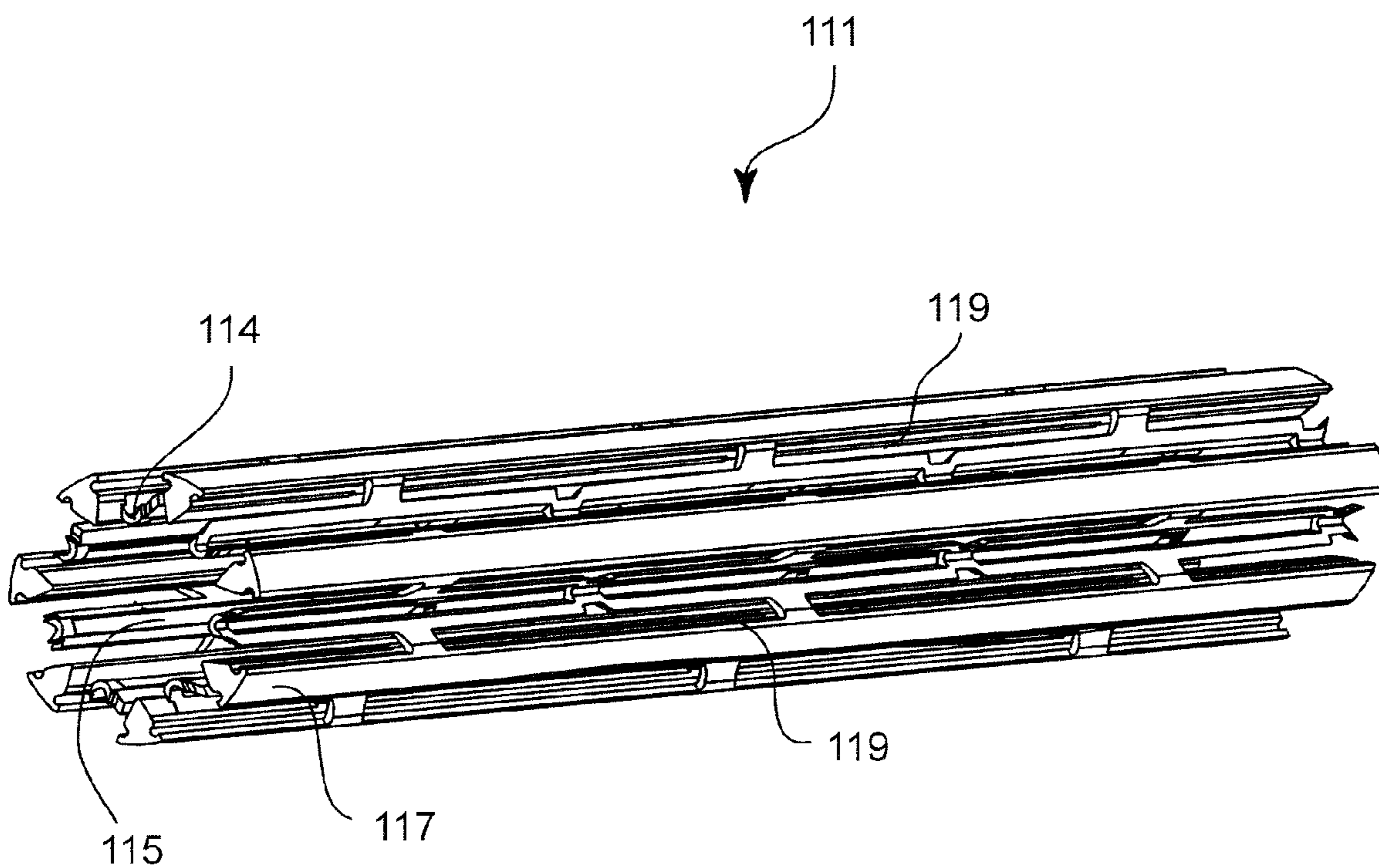

Fig. 15

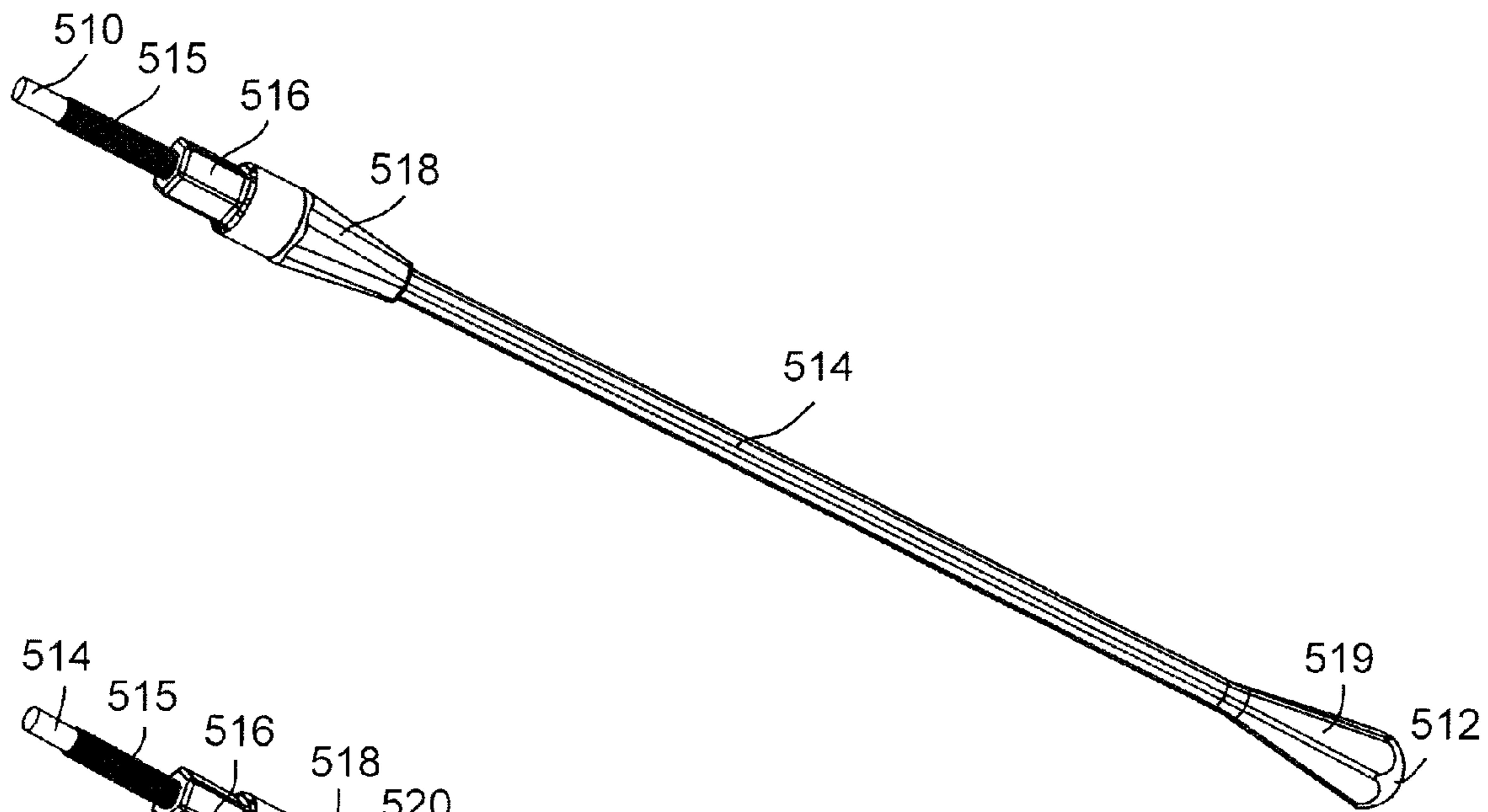

Fig. 16A

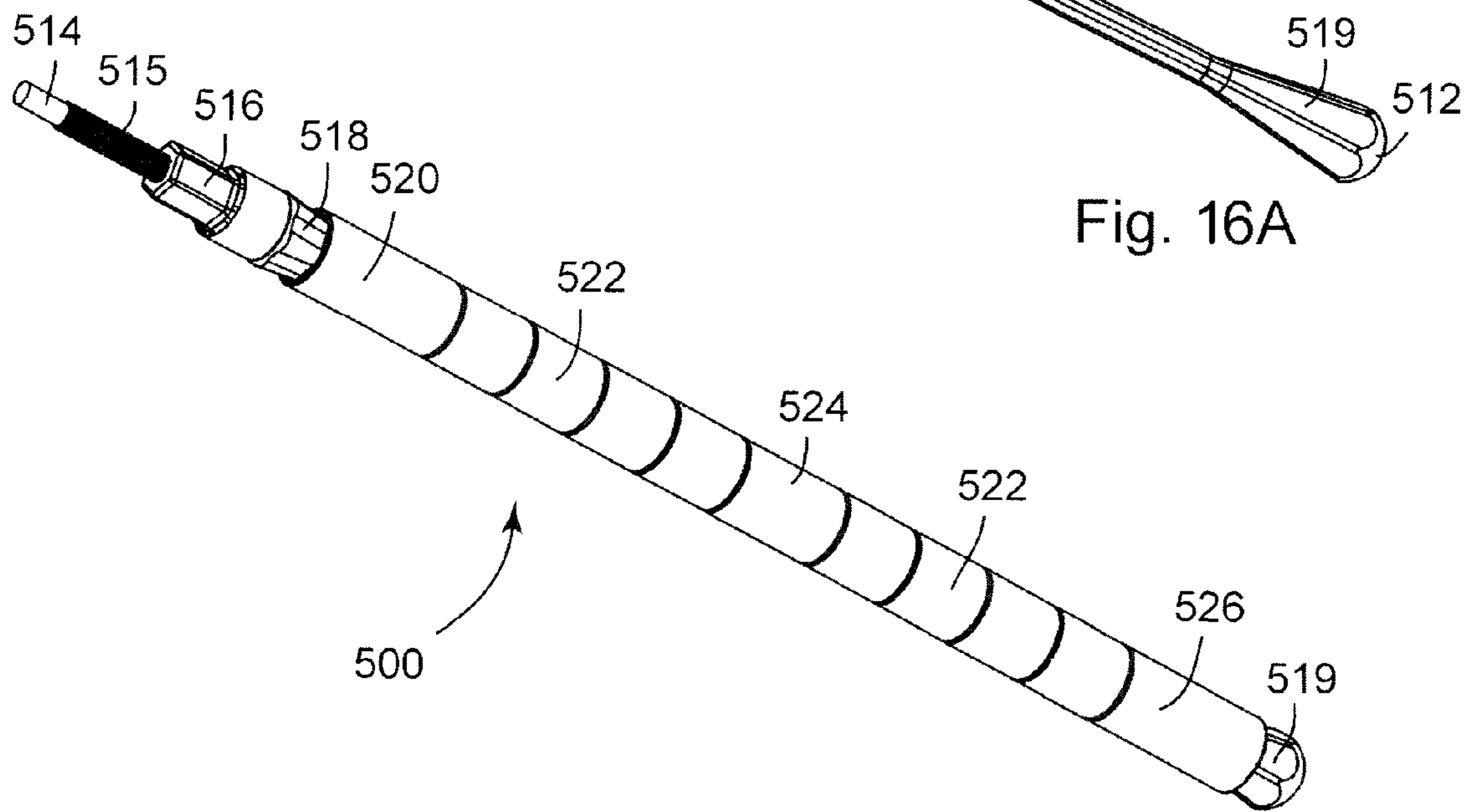
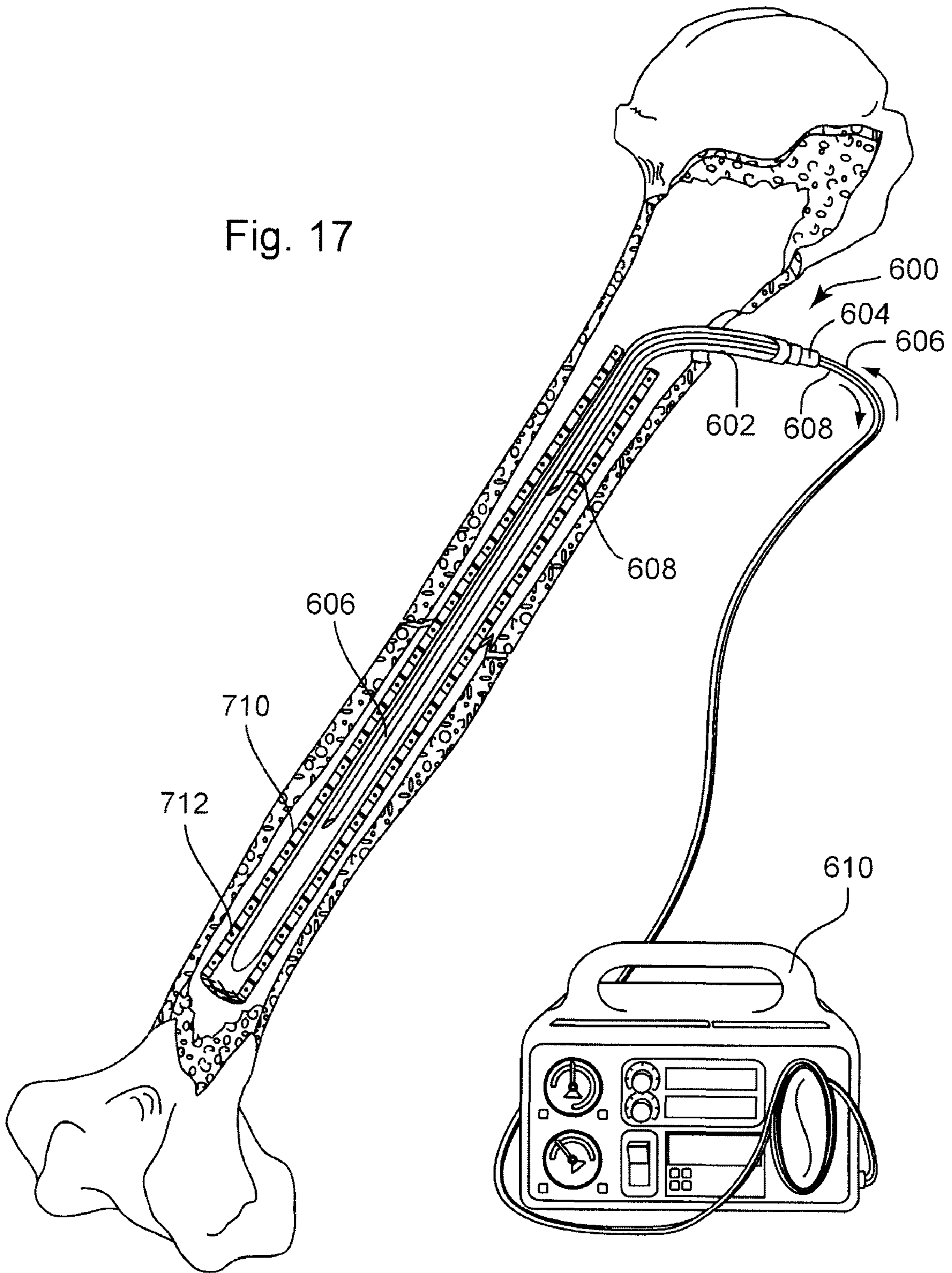

Fig. 16B

Fig. 17



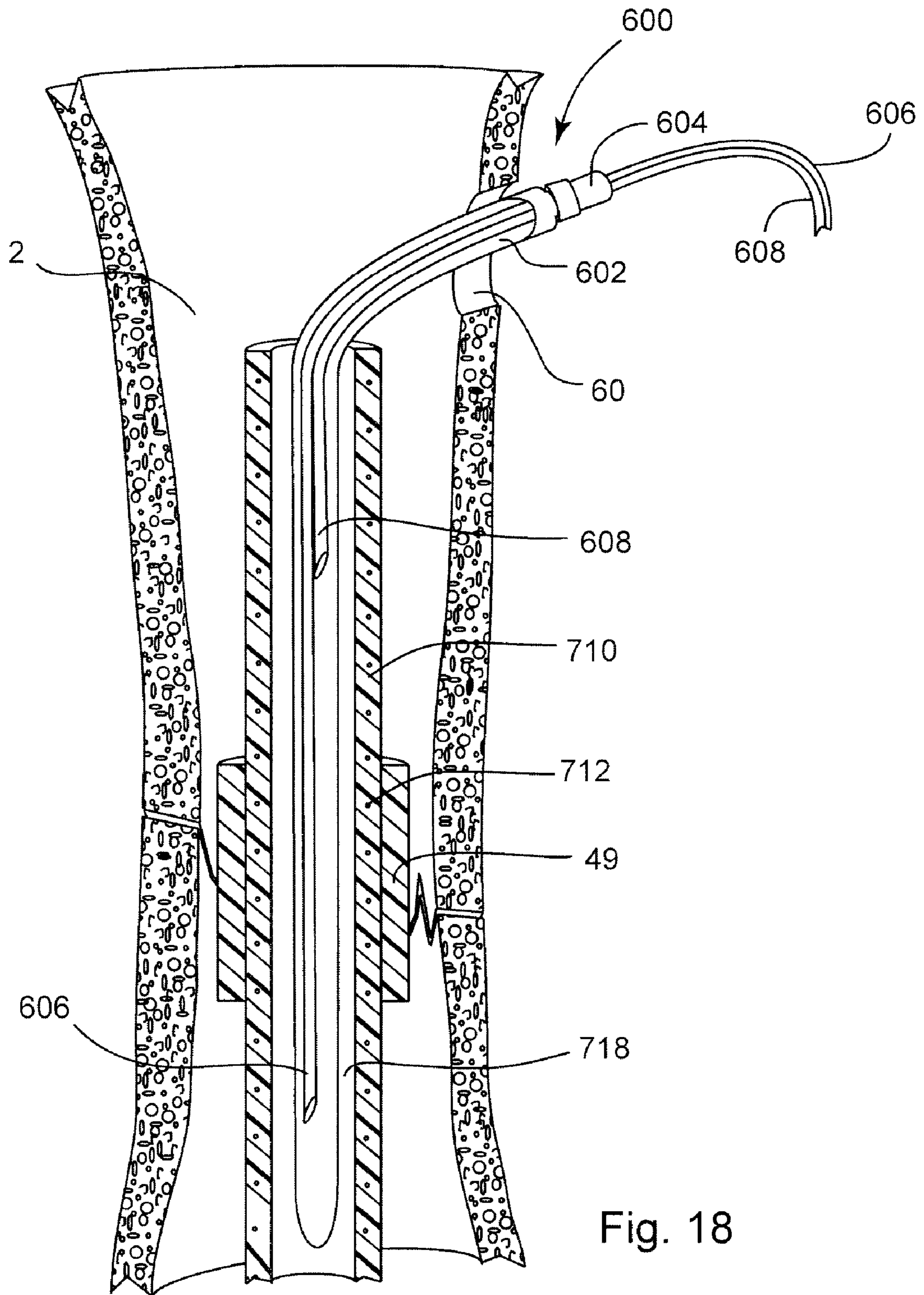

Fig. 18

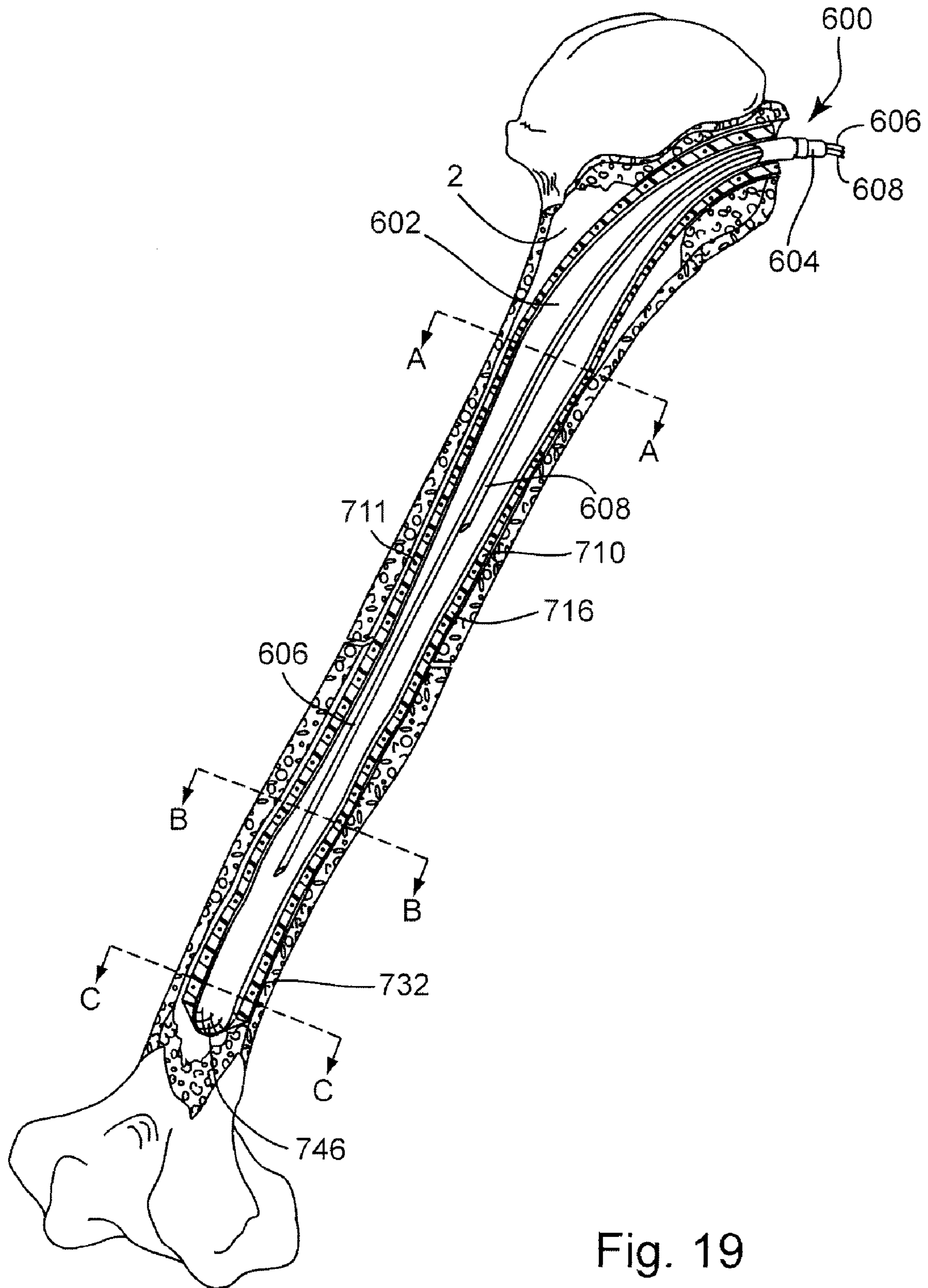
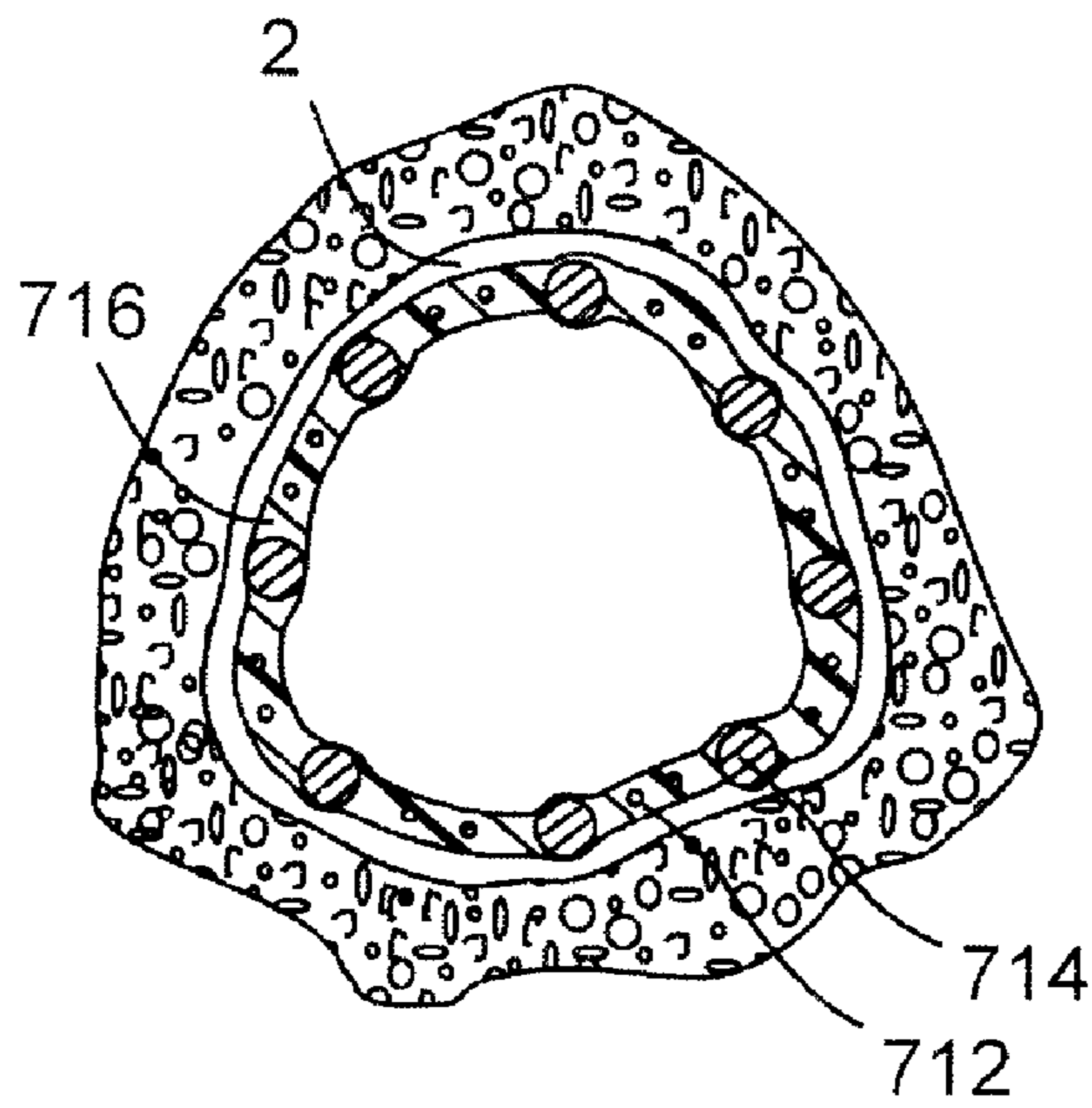
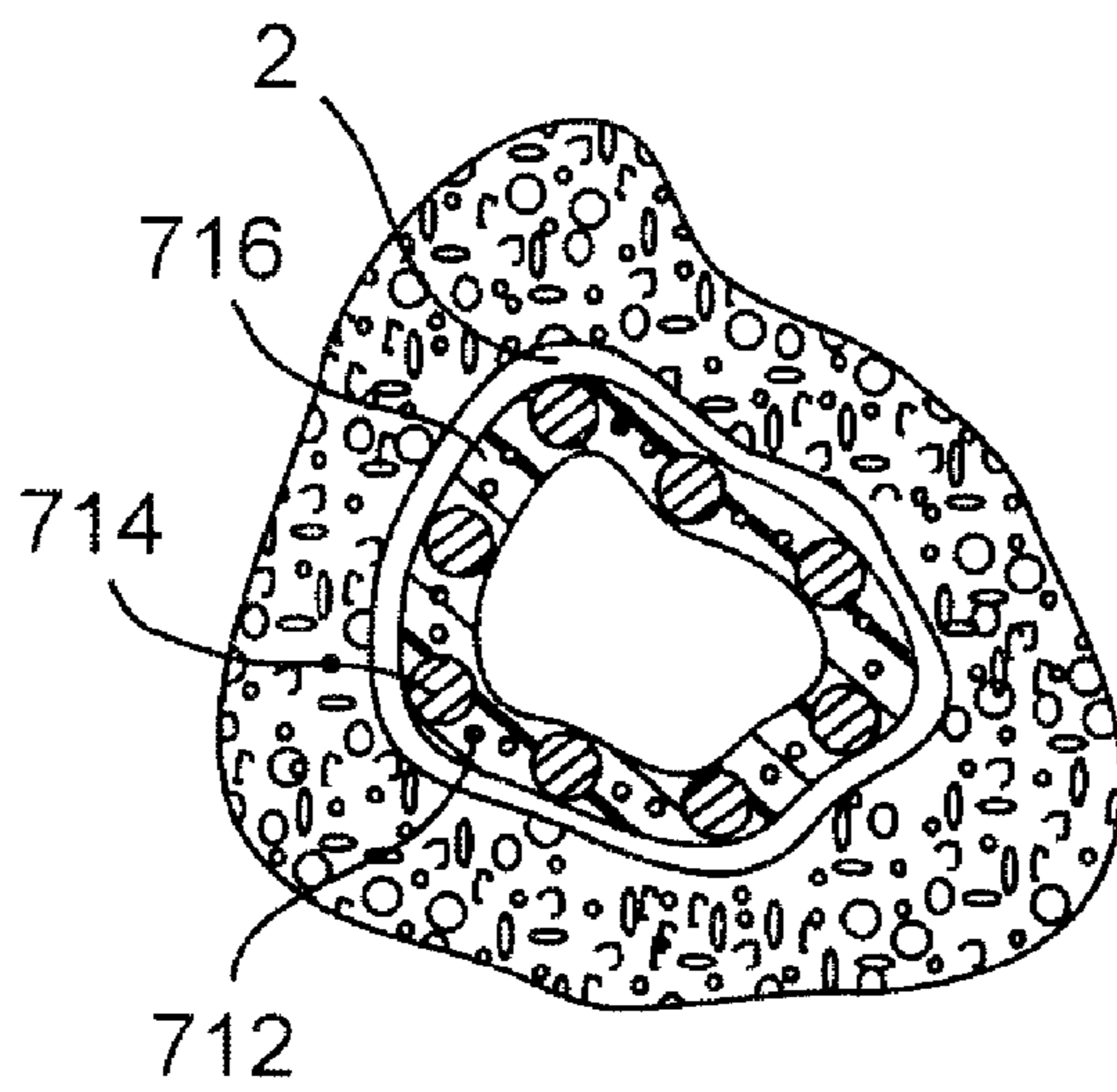

Fig. 19



A-A

Fig. 20A



B-B

Fig. 20B

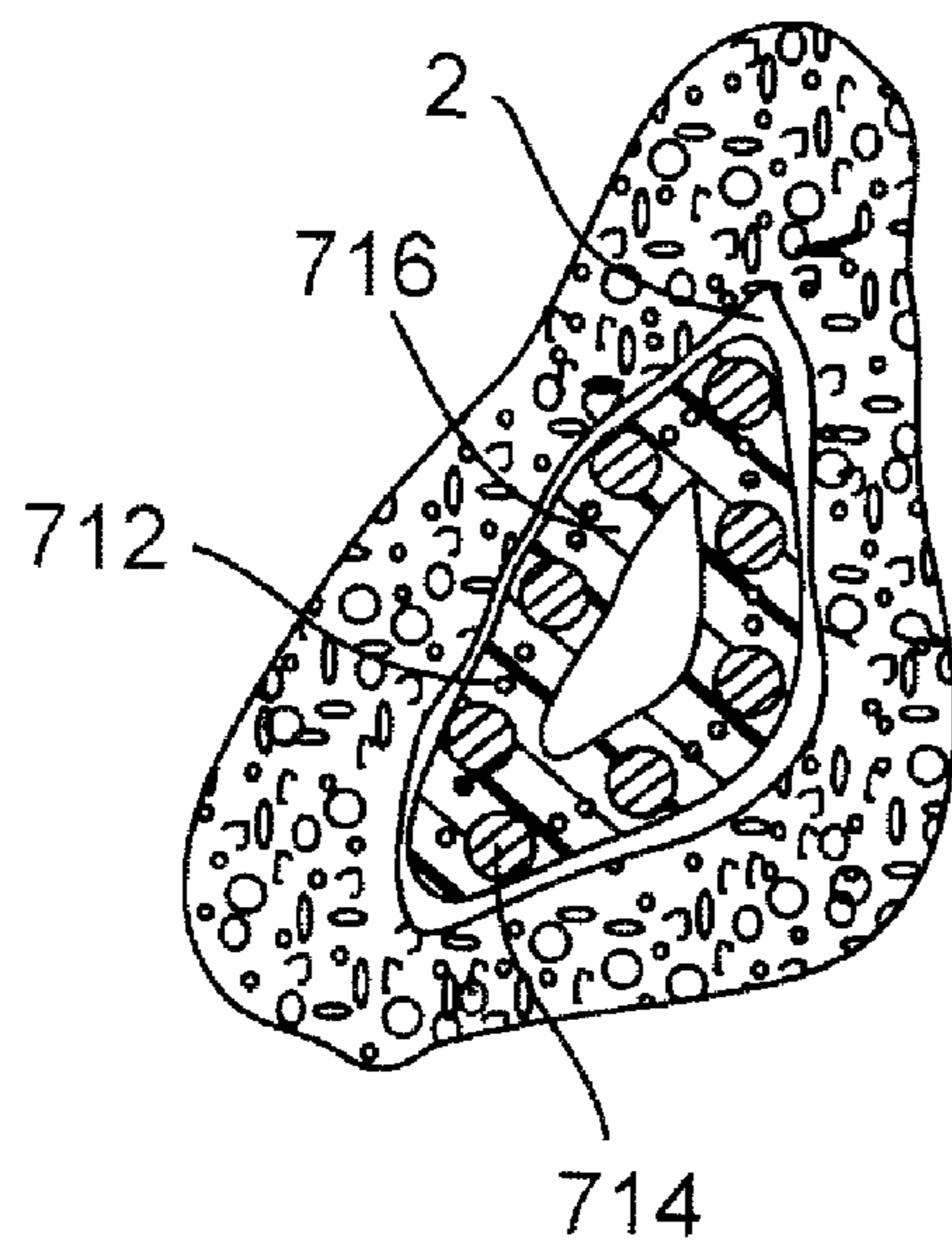

C-C

Fig. 20C

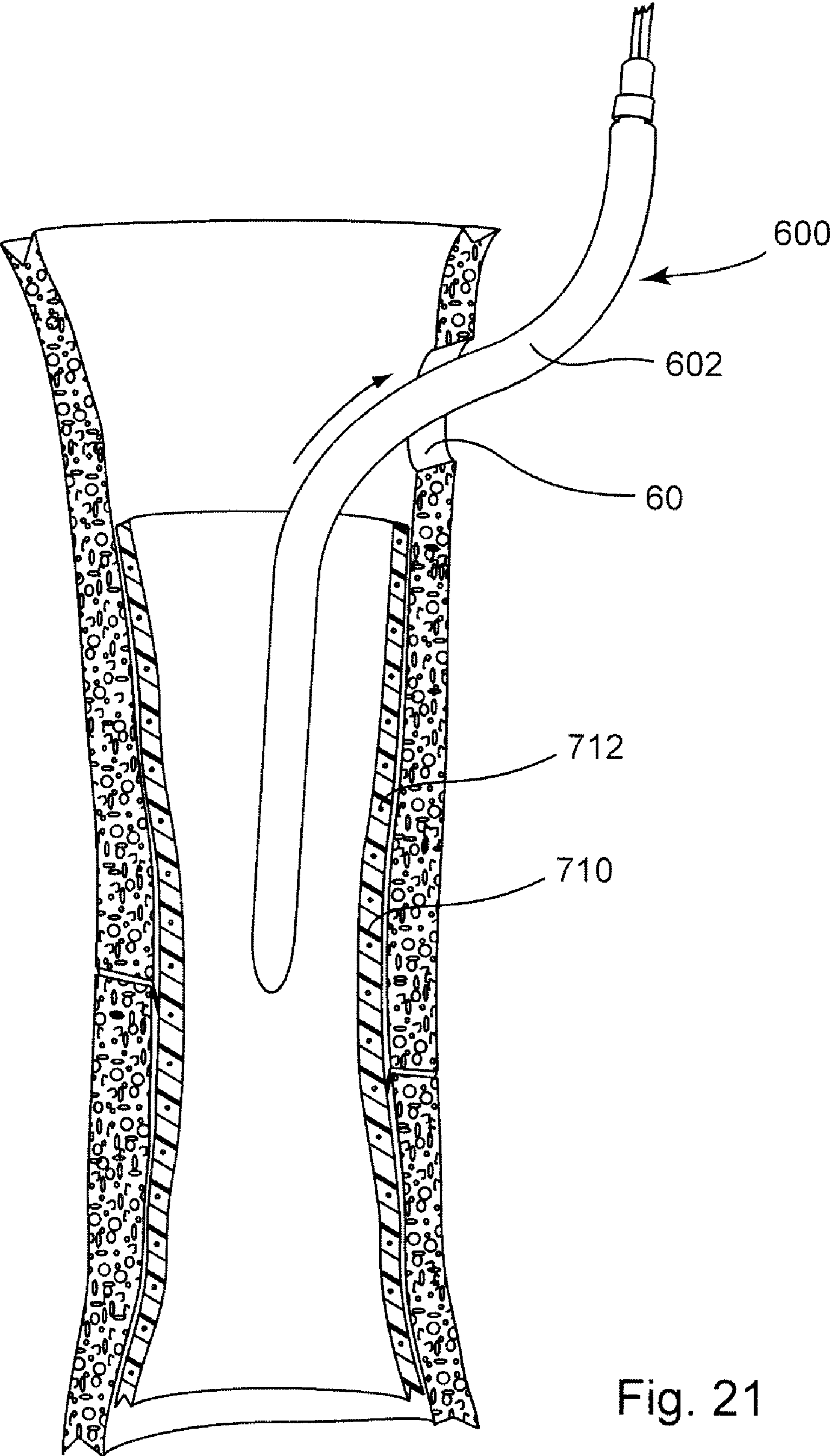

Fig. 21

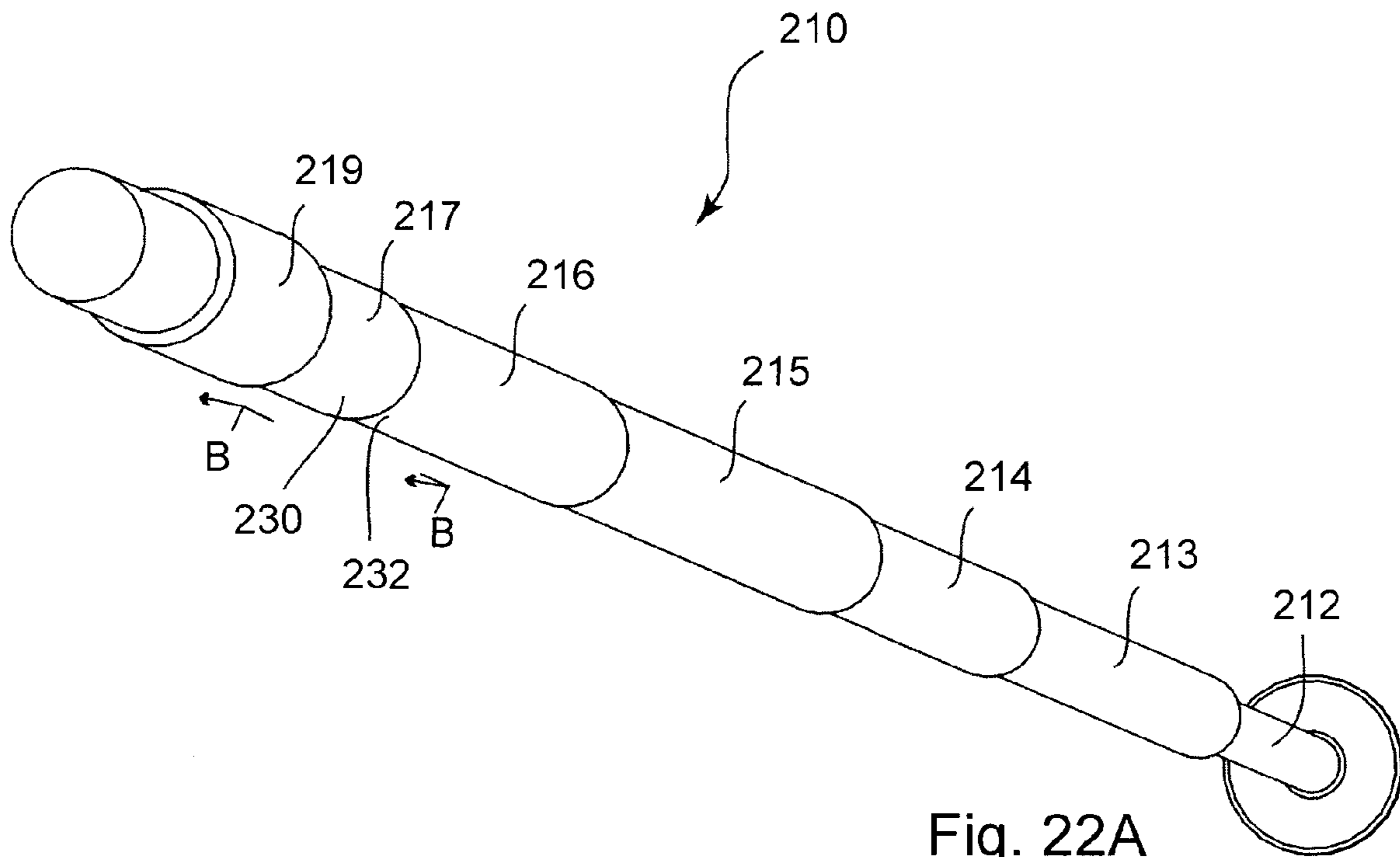

Fig. 22A

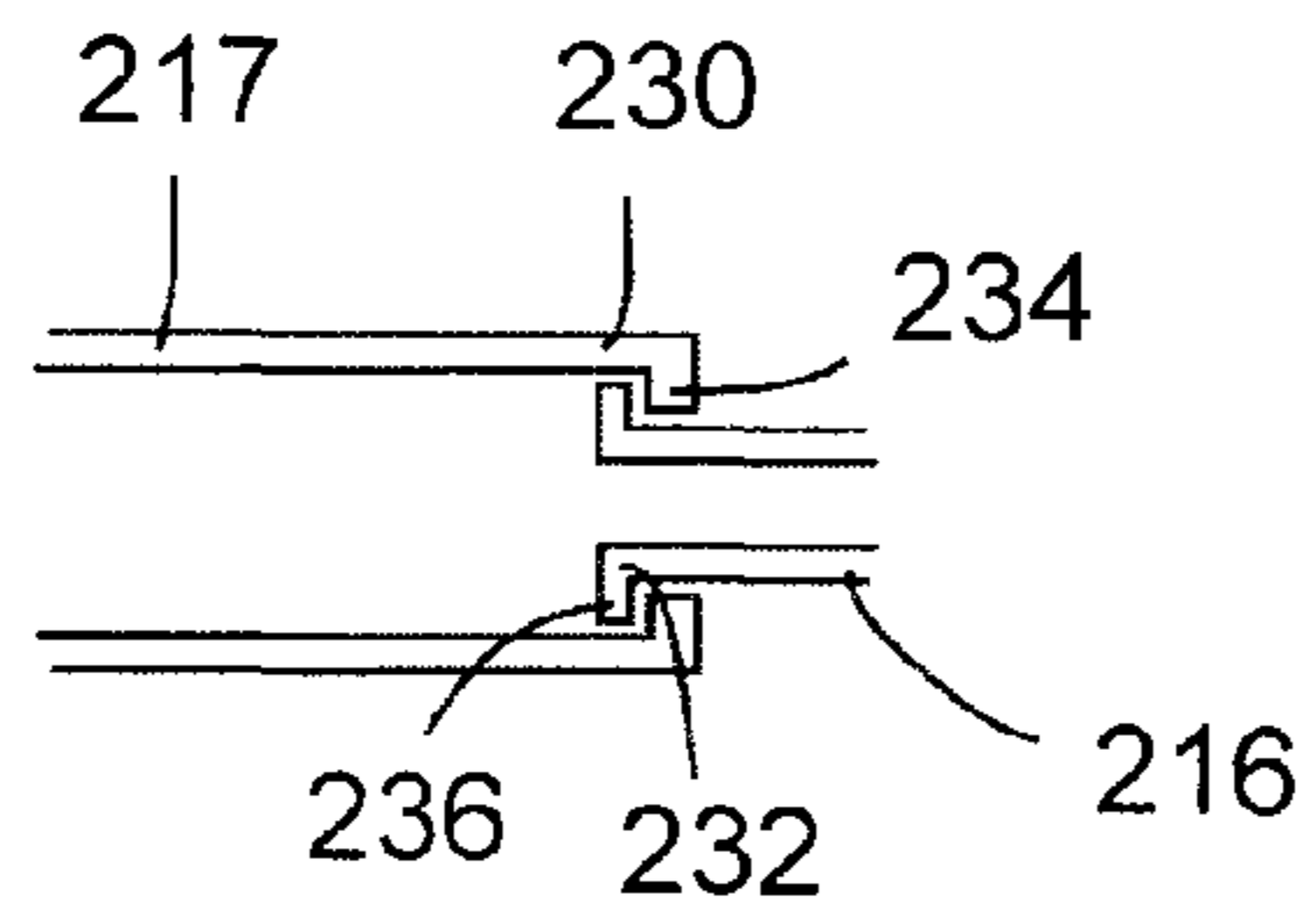

Fig. 22B

B-B

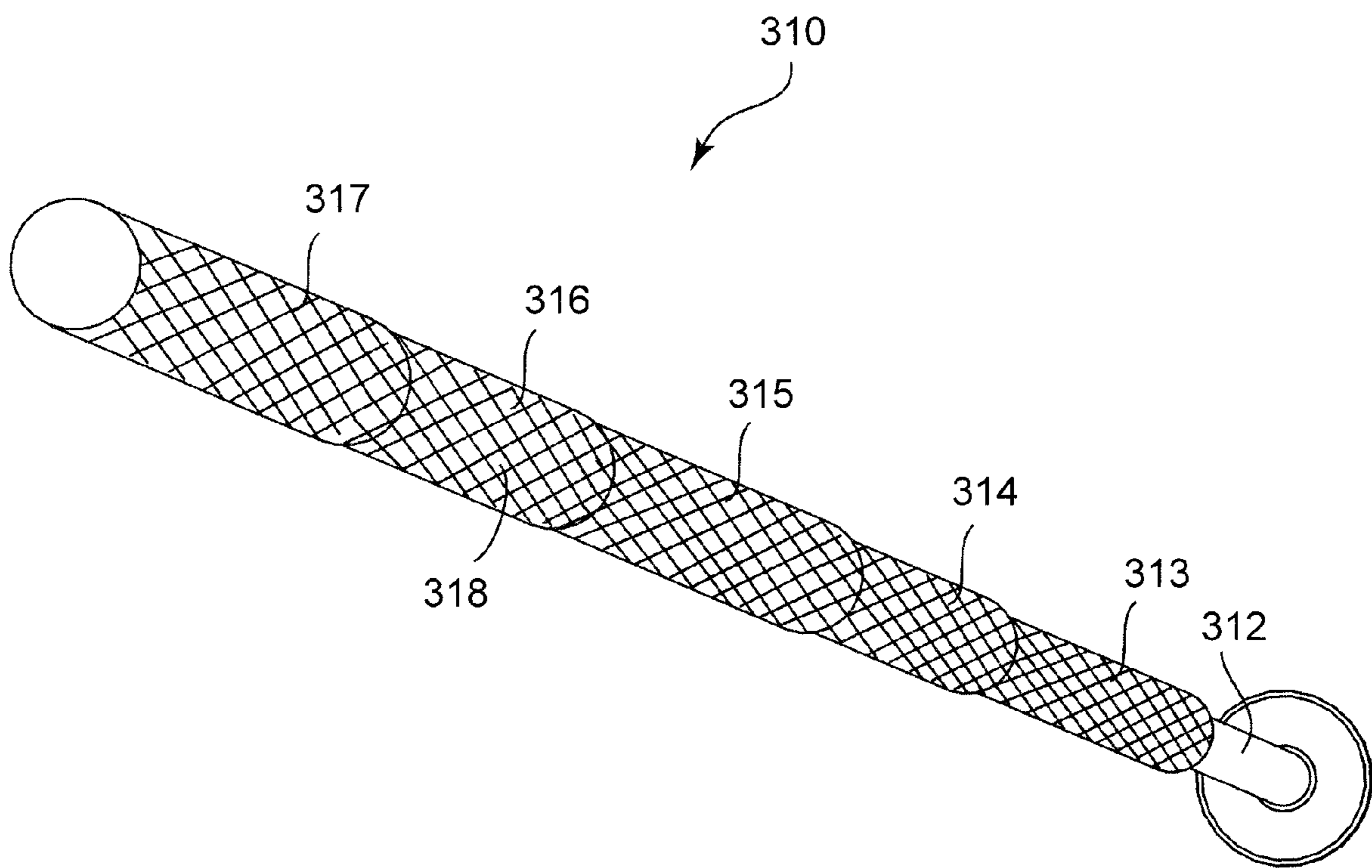

Fig. 23

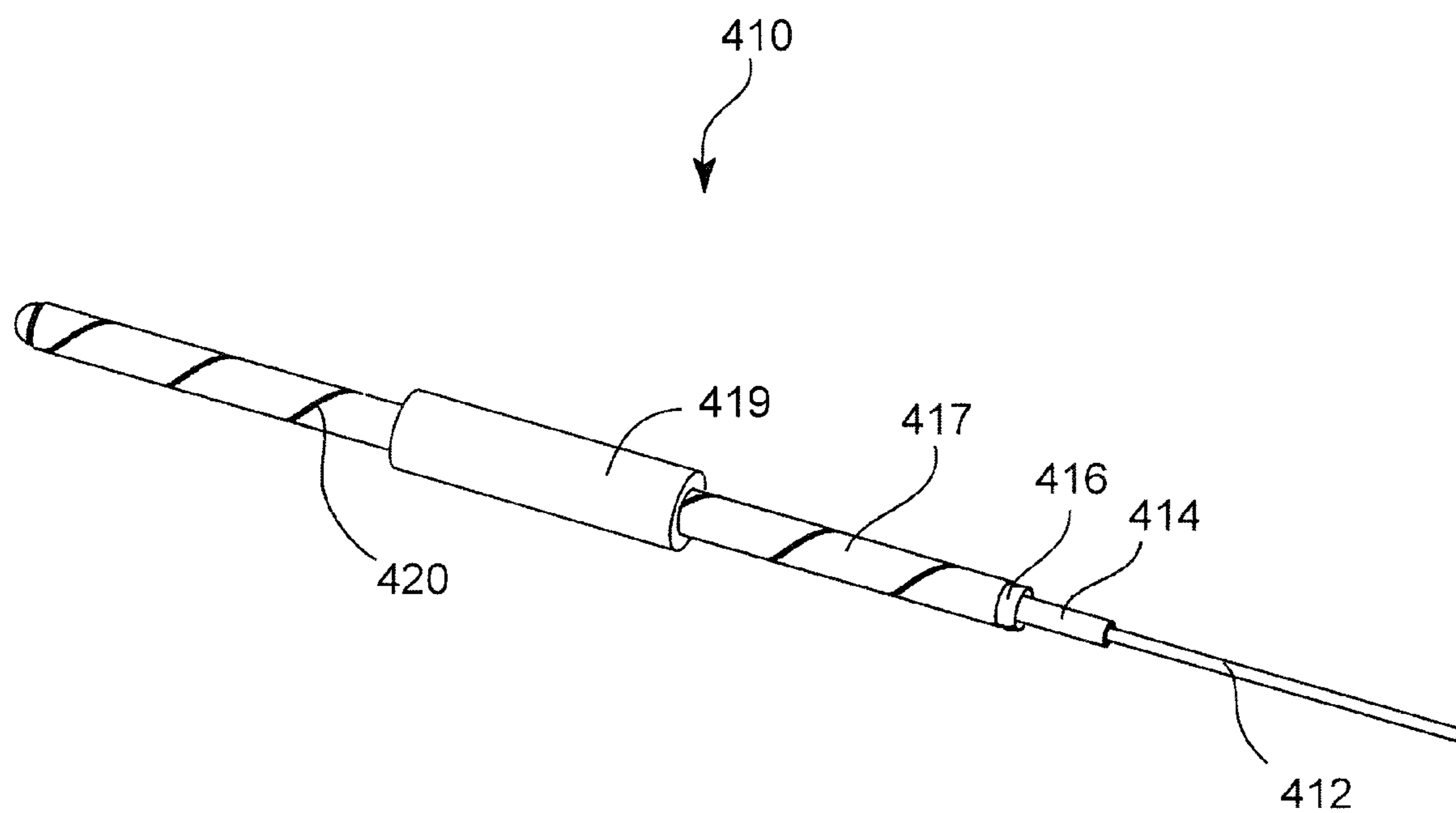

Fig. 24

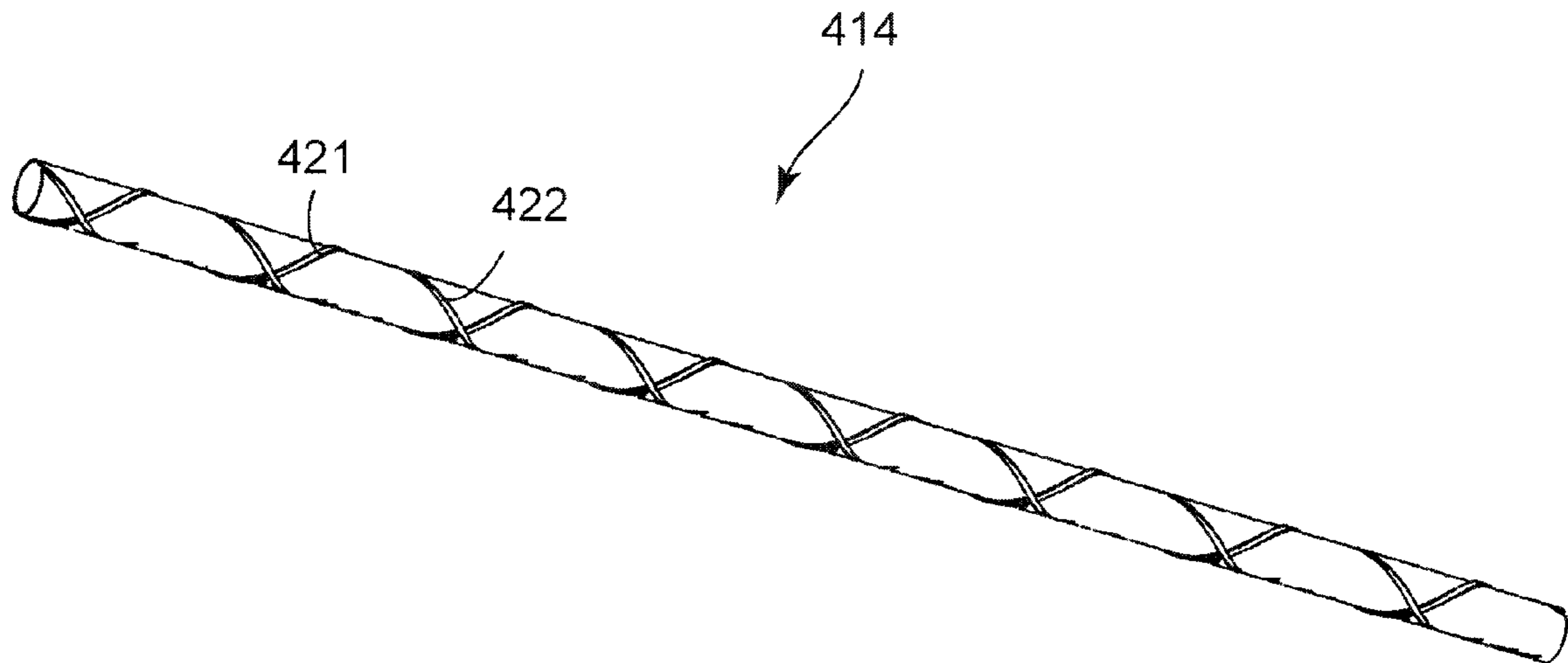

Fig. 25A

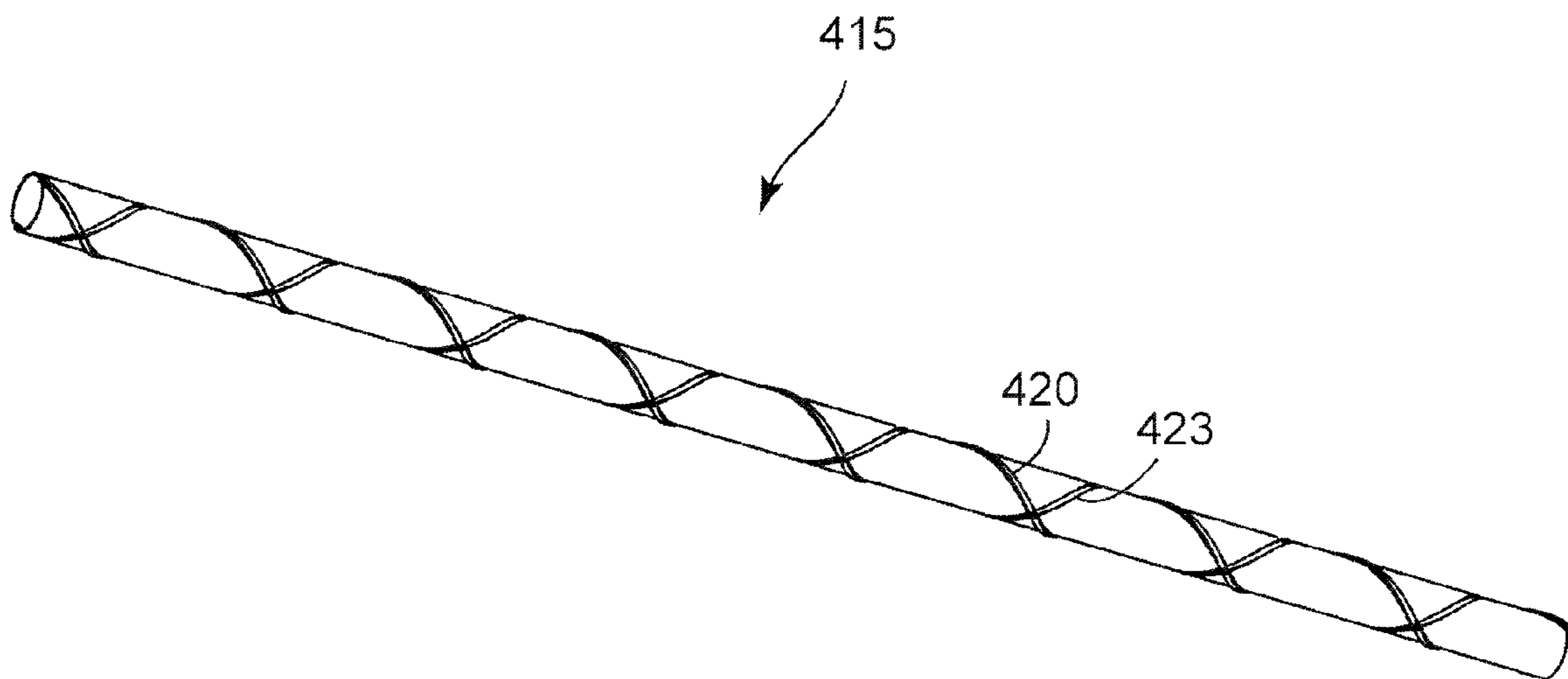

Fig. 25B

1

**SYSTEM AND METHOD FOR DELIVERY
CONFORMATION AND REMOVAL OF
INTRAMEDULLARY BONE FIXATION
DEVICES**

CROSS-REFERENCE TO RELATED
APPLICATIONS

This application claims the benefit of the following, which is incorporated herein by reference:

Prior U.S. Provisional Patent Application No. 60/913,696, filed Apr. 24, 2007, and is entitled THERMO-CHEMICALLY ACTIVATED INTRAMEDULLARY BONE STENT.

BACKGROUND OF THE INVENTION

1. The Field of the Invention

The present invention relates generally to orthopedic devices for the surgical treatment of bone fractures and, more particularly, to the fixation and stabilization of fracture sites with an intramedullary device that is deformable and conforms to the shape of the intramedullary canal.

2. The Relevant Technology

Orthopedic medicine provides a wide array of implants that can be attached to bone to repair fractures. External fixation involves the attachment of a device that protrudes out of the skin, and therefore carries significant risk of infection. Many fractures in long bones can be repaired through the use of bone plates, which are implanted and attached to lie directly on the bone surface. The bone plate then remains in the body long enough to allow the fractured bone to heal properly. Unfortunately, such bone plates often require the surgical exposure of substantially the entire length of bone to which the plate is to be attached. Such exposure typically results in a lengthy and painful healing process, which must often be repeated when the implantation site is again exposed to allow removal of the plate. There is a need in the art for implants and related instruments that do not require such broad exposure of the fractured bone, while minimizing the probability of infection by avoiding elements that must protrude through the skin as the bone heals.

BRIEF DESCRIPTION OF THE DRAWINGS

Various embodiments of the present invention will now be discussed with reference to the appended drawings. It is appreciated that these drawings depict only typical embodiments of the invention and are therefore not to be considered limiting of its scope. The drawings may not be to scale.

FIG. 1 is a perspective view of an intramedullary bone fixation device according to one embodiment of the invention, comprising a support structure which includes a cage and a plurality of rods, and a thermo-chemically activated thermoplastic matrix;

FIG. 2 is a perspective view of the cage of FIG. 1;

FIGS. 3A-3I are perspective views of various embodiments of stent portions suitable for incorporation into the support structure of FIG. 2;

FIG. 4 is an enlarged perspective view of a first end of the cage of FIG. 2;

FIG. 5 is a perspective view of the rods of FIG. 1;

FIG. 6 is a perspective view of the thermoplastic matrix of FIG. 1;

FIG. 7 is a longitudinal cross-sectional view of a bone with an alternative embodiment of an intramedullary bone fixation device partially inserted into the intramedullary canal;

2

FIG. 8 is a longitudinal cross-sectional view of a bone with the intramedullary bone fixation device of FIG. 7 implanted inside a second intramedullary bone fixation device;

FIG. 9A is an enlarged cross-sectional view of one section of the bone and intramedullary bone fixation devices of FIG. 8;

FIG. 9B is an enlarged cross-sectional view of another section of the bone and intramedullary bone fixation devices of FIG. 8;

FIG. 9C is an enlarged cross-sectional view of another section of the bone and intramedullary bone fixation devices of FIG. 8;

FIG. 10 is a perspective cutaway view of an alternative embodiment of an intramedullary bone fixation device comprising a cage, rods, sutures and a thermoplastic matrix;

FIGS. 11A-11E are cross-sectional views of the intramedullary bone fixation device of FIG. 10, illustrating radial expansion of the device from a contracted state in FIG. 11A to a fully expanded state in FIG. 11E.

FIGS. 12A-12E are cross-sectional views of an alternative embodiment of an intramedullary bone fixation device, illustrating radial expansion of the device from a contracted state in FIG. 12A to a fully expanded state in FIG. 12E.

FIG. 13A is a perspective view of a support structure in a contracted state according to one alternative embodiment of the invention;

FIG. 13B is a perspective view of the support structure of FIG. 13A in an expanded state;

FIG. 14A is a perspective view of a cage in a contracted state;

FIG. 14B is an end view of the cage of 14A in a contracted state;

FIG. 14C is a perspective view of a cage in an expanded state;

FIG. 14D is an end view of the cage of 14C in an expanded state;

FIG. 15 is a perspective view of a slotted support structure;

FIG. 16A is a perspective view of a shaft portion of a mechanical expansion apparatus suitable for use with the device of FIG. 1;

FIG. 16B is a perspective view of the complete mechanical expansion apparatus of FIG. 16A;

FIG. 17 is a longitudinal cross-sectional view of a bone with an intramedullary bone fixation device in a contracted state and a balloon expansion apparatus in the intramedullary canal of the bone, and a regulator apparatus;

FIG. 18 is a longitudinal cross-sectional view of a portion of the bone of FIG. 17, with the intramedullary bone fixation device in a contracted state and a balloon expansion apparatus of FIG. 17;

FIG. 19 is a longitudinal cross-sectional view of the bone, intramedullary bone fixation device and balloon expansion apparatus of FIG. 17, with the balloon in an inflated state and the intramedullary bone fixation device in an expanded state;

FIG. 20A is an enlarged cross-sectional view of one section of the bone and intramedullary bone fixation device of FIG. 19;

FIG. 20B is an enlarged cross-sectional view of another section of the bone and intramedullary bone fixation device of FIG. 19;

FIG. 20C is an enlarged cross-sectional view of another section of the bone and intramedullary bone fixation device of FIG. 19;

FIG. 21 is a longitudinal cross-sectional view of the bone, intramedullary bone fixation device and balloon expansion apparatus of FIG. 17, with the balloon in a deflated state and the and intramedullary bone fixation device in an expanded

3

state, with the balloon expansion apparatus partially removed from the intramedullary bone fixation device;

FIG. 22A is a perspective view of a telescoping bone fixation device in an extended state according to one alternative embodiment of the invention;

FIG. 22B is a longitudinal cross-sectional view of a connection between two nesting components of the telescoping bone fixation device of FIG. 22A;

FIG. 23 is a perspective view of a telescoping bone fixation device with mesh-like components and a thermoplastic matrix according to another alternative embodiment of the invention, in an extended state;

FIG. 24 is a perspective view of a helically threaded telescoping bone fixation device according to yet another alternative embodiment of the invention, in a partially extended state;

FIG. 25A is a perspective view of one nesting component of the helically threaded telescoping bone fixation device of FIG. 24; and

FIG. 25B is a perspective view of another nesting component of the helically threaded telescoping bone fixation device of FIG. 24.

DETAILED DESCRIPTION OF THE PREFERRED EMBODIMENTS

Referring to FIG. 1, a perspective view illustrates an embodiment of an intramedullary bone fixation composite device 10. The composite device 10 comprises a support structure 11 and a thermo-chemically activated thermoplastic matrix 16. The support structure 11 comprises a cage 12, and at least one stiffening rod 14. The composite device 10 is generally tubular in form and has a longitudinal axis 24 and a transverse axis 26. A hollow central core 18 extends the length of the device 10, surrounded by the cage 12 and rods 14, which are embedded in the thermoplastic matrix 16. An outer perimeter 22 bounds the outer surface of the composite device 10. The composite device 10 is an implant which is able to transition from a contracted and flexible state for introduction into the intramedullary canal, to an expanded and hardened state providing rigid support and alignment for fixation of the surrounding bone, once implanted and allowed to expand to the perimeter of the canal. The thermoplasticity of the matrix 16 allows the composite device 10 to conform to the shape of the surrounding intramedullary canal at a first state, and harden in its conformed shape at a second state providing torsional, axial, and bending reinforcement of the bone fragments during bone healing. When contracted for insertion (or removal), a diameter 20 along the transverse axis 26 of the device is reduced, and the length along the longitudinal axis 24 of the device may be constant or increased. When expanded within the intramedullary canal, the diameter 20 is increased, and the length may be constant or decreased.

As seen in FIG. 2, the cage 12 is an elongated, generally web-like tube which allows radial expansion and contraction over at least part and preferably all of its length, and bending flexibility as bending loads are applied. The cage 12 has a first end 30, a second end 32 and a sleeve 34 which extends between the ends. The sleeve 34 has an attachment portion 36 and a web-like stent portion 38. The cage is hollow and generally circular in cross-sectional shape, although the web-like construction allows the cross-sectional shape to vary to conform to the contours of the surrounding intramedullary canal. The shape of the intramedullary canal varies along its length, and its cross-sectional shape may be substantially circular, generally triangular or another shape. The cage 12 may comprise a tubular woven or braided cage, a laser cut

4

tubing cage, a machined cage, or a chemically etched tubing cage made from materials such as Nitinol, stainless steel, Co—Cr, Titanium alloys, Tantalum, plastic, polymer or other biocompatible materials, among others. In the embodiment depicted, the stent portion 38 comprises a majority of the sleeve 34. However, in other embodiments the stent portion may be a smaller proportion of the sleeve, or comprise the entire sleeve. Attachment portions 36 may be located at one, both, or neither of the ends of the sleeve, or intermittently along the sleeve length.

Referring to FIG. 3, possible configurations of the web-like structure of the stent portion 38 are shown, comprising examples of commercially available stent shapes. These figures show the approximate pattern of the web-like structure. These patterns are adaptable to a variety of lengths, diameters, density of repeatable patterns, wire thicknesses, web areas, and other structural characteristics such that the general stent shape can be configured to a particular bone morphology and size. FIG. 3A is representative of a Johnson and Johnson Palmaz-Schatz™ Version 2 stent. FIG. 3B represents a Medtronic Wiktor™ stent. FIG. 3C represents the general shape of a Schneider “Magic” Wallstent™ stent. FIG. 3D represents a Scimed NIR™ stent. FIG. 3E represents an Arterial Vascular Engineering (AVE™) Microstent. FIG. 3F is representative of a Biotronik Stent™. FIG. 3G is meant to represent the general shape and construct of a Johnson and Johnson Palmaz-Schatz™ stent. FIG. 3H represents a Global Therapeutics Freedom™ stent. FIG. 3I is drawn to represent the adaptable structure of a Scimed Radius™ stent which like all the previously presented representative figures can be configured to the length, diameter and size needed to conform to the intramedullary shape of a particular bone. The stent portion may also be configured with more than one pattern along its length or diameter if needed to better conform to the desired geometry. The stent portion need not be a commercially available stent; it may also have a unique configuration which is constructed from wire, woven, machined, laser cut, or chemically etched.

FIG. 4 is an enlarged view of the first end 30, the attachment portion 36 and part of the stent portion 38 of the cage 12. The attachment portion 36 comprises struts 40 which extend from the stent portion 38 and terminate at loops 42, which allow for the attachment of instruments for device placement, adjustment and removal. Other fasteners such as holes or hooks, among others, may be used instead of loops. Between the struts 40 at the first end 30, linkages 44 connect each strut to the adjacent strut. The linkages allow for radial and longitudinal contraction and expansion of the struts 40 and therefore the first end 30, as the device is contracted and expanded during implantation and removal. The web-like configuration of the stent portion 38 allows for radial and longitudinal contraction and expansion of the remainder of the cage 12.

Referring to FIG. 5, at least one, and optionally, a plurality, of stiffening rods 14 are oriented parallel to the longitudinal axis of the cage 12 and are contained by the cage in such a way as to allow the stiffening rod(s) to move radially with the cage as the cage contracts and expands. Each rod 14 has a first end 50, a second end 52 and a shaft 56. Each rod 14 may have loops, holes, hooks or other attachment structures at the second end 52 to connect to second end 32 of cage 12. The rods 14 may be threaded loosely or otherwise linked into the stent portion 38 of the cage 12. Holes (not shown) may extend transversely through the rods, and individual webs of the stent portion may pass through the holes to retain the rods. The rods 14 may extend the full length of the cage 12, or preferably from the second end 32 of the cage to the upper end of the stent portion 38. The stiffening rods 14 can be made from any

5

biocompatible material such as stainless steel, cobalt chromium alloys, tantalum, zirconium alloys, titanium or titanium alloys, particularly beta titanium alloys. The stiffening rods **14** can also be made from non-metal biocompatible materials such as PEEK, Acetal, bioabsorbable materials, ceramics and biocomposites. Each stiffening rod **14** is sufficiently flexible to temporarily bend as the device (in a contracted state) is introduced into the intramedullary canal. Additionally, the rods may be knurled, threaded or otherwise treated to provide adhesion and interdigitation of the matrix and cage. Once the device **10** is inserted and expanded radially, the rods **14** are aligned parallel to the longitudinal axis of the bone and line the inner surface of the canal, within the cage and matrix of the device.

The ratio of longitudinal contraction to radial expansion of the composite device **10** varies depending upon the configuration of the stent portion of the cage, the length of the linkages, and the length and placement of the rods. Some embodiments have a low ratio, in which a small decrease in the length of the cage results in a large increase in the radial expansion (as measured by change in the core diameter **20**). Other embodiments have a 1:1 ratio (a contraction in cage length results in an equal measurement of radial expansion), or a higher ratio, in which a large decrease in longitudinal contraction produces a small increase in radial expansion. The choice of embodiment will depend upon factors such as the length and diameter of the particular bone to be fixed, accessibility to the bone, and severity of the fracture, among others.

Referring to FIG. **6**, the thermoplastic matrix **16** may be thermo-chemically activated, and may surround the support structure **11** of FIG. **2**, or the support structure of any of the embodiments described below. The matrix **16** comprises a material which has physical properties that change between a first and second state. For example, the material may be flexible and deformable at a first state and hard and more rigid at a second state. This can be accomplished by changing factors such as the molecular structure of chemical components of the matrix **16** from one state to another. Methods of changing the molecular structure of a material, and thus the physical properties of the material, include changing the temperature of the material, exposing the material to gamma radiation and altering the crosslinking bonds between molecular chains in the material, exposing the material to ultraviolet radiation causing the material to cure and harden, exposing the material to a second material allowing crosslinking and molecular bonding, allowing the material to harden over time by increasing the crystallinity within the molecular structure, and other methods that alter the bonding between the molecules in the matrix **16** material and correspondingly alter its material properties.

The matrix **16** may comprise a thermoplastic biocompatible polymer or polymer blend comprising polymers such as polylactic acid (PLA), poly ϵ -caprolactone (PCL), trimethylene carbonate (TMC), polyglycolic acid (PGA), poly l-lactic acid (PLLA), poly d-l-lactide (PDLLA), poly-D,L-lactic acid-polyethyleneglycol (PLA-PEG) or other biocompatible polymers. Each of these polymers has a glass transition temperature T_g such that when raised to a temperature above its T_g , the polymer is rubbery, flexible and deformable. When lowered to a temperature below its T_g , the polymer is crystallized and substantially rigid. Each of these polymers or blends is capable of being transformed by the application of energy to a first thermo-chemical state, in which it is at a temperature above its glass transition temperature T_g . When, through dissipation of energy, the temperature is reduced to below T_g , the polymer or blend is at a second thermo-chemi-

6

cal state. These thermoplastic properties of the polymers allow them to be repetitively heated to above T_g , and subsequently cooled to below T_g , moving repeatedly between the first and second thermo-chemical states.

Preferred polymers have a glass transition temperature T_g that is above body temperature, but below the temperature known to cause thermal necrosis of tissues. A preferred blend is crystallized and substantially rigid at human body temperature, and has a T_g which ranges from about 10° C. above body temperature to about 35° C. above body temperature. This acceptable T_g range is between about 50° C. and about 80° C., and preferably between about 55° and about 65° C. Preferably, the thermoplastic matrix **16** comprises a blend of polymers such as PCL and PLA, or PCL and PGA. Table 1 displays the melting points (T_m), glass transition temperatures (T_g) and thermal decomposition temperatures (T_{dec}) of selected synthetic absorbable polymers.

TABLE 1

Melting, glass transition and thermal decomposition temperatures of selected synthetic absorbable polymers.			
Polymer	T_m (° C.)	T_g (° C.)	T_{dec} (° C.)
PGA	230	36	260
PLLA	170	56	240
PLA	—	57	—
PCL	60	-62	—
Polyglactin910	200	40	250
Polydioxanone	106	<20	190
Polyglyconate	213	<20	260

Additional biocompatible polymers which may be included in the matrix **16**, individually or in a blend, comprise aliphatic polyesters including polyglycolide, poly(dl-lactide), poly(l-lactide), poly(δ -valerolactone), polyhydroxybutyrate; polyanhydrides including poly[bis(p-carboxyphenoxy) propane anhydride], poly(carboxy phenoxyacetic acid), poly(carboxy phenoxyvaleric acid); polyphosphazenes including aryloxyphosphazene polymer and amino acid esters; poly (ortho esters); poly(p-dioxane); poly(amino acids) including poly(glutamic acid-co-glutamate); erodable hydrogels; and natural polymers including collagen (protein) and chitosan (polysaccharide).

The thermoplastic matrix **16** may further include at least one bioactive material to promote growth of bone material and accelerate healing of fractures. These bioactive materials include but are not limited to hydroxylapatite, tetracalcium phosphate, β -tricalcium phosphate, fluorapatite, magnesium whitlockite, β -whitlockite, apatite/wollastonite glass ceramic, calcium phosphate particle reinforced polyethylene, bioactive glasses, bioactive glass ceramics, polycrystalline glass ceramics, and polyethylene hydroxylapatite.

The support structure **11** may be embedded in the thermoplastic matrix **16** through insert molding, pulltrusion, by dipping the support structure into the thermoplastic matrix material while it is at a temperature above T_g , or by other coating methods. A variety of different methods may alternatively be used to assemble the thermoplastic matrix **16** and the support structure **11**.

Referring to FIG. **7**, a longitudinal cross-section of a bone illustrates implantation of an intramedullary bone fixation composite device **710**. The method illustrated in FIG. **7** may also be used for implantation of composite device **10** and other devices according to alternative embodiments. Composite device **710** comprises a support structure **711** and a thermo-chemically activated thermoplastic matrix **716**. The

support structure 711 comprises a stent-like cage 712 (not shown) and a plurality of rods 714 (not shown).

A percutaneous portal 60 is created into the intramedullary canal 2, preferably in the proximal or distal metaphysial region of the bone. The opening may not be parallel to the longitudinal axis of the bone; it may be transverse or at an acute angle relative to the longitudinal axis of the bone. If necessary to open the canal space and prepare it for the implant, the canal is evacuated using a sequence of pulse lavage, brushing, and suction. A delivery tube 62 may be advanced into the percutaneous portal 60. The composite device 710, in a lengthened and contracted state, is heated immediately prior to implantation to a first thermo-chemical state, so that the thermoplastic matrix 716 is above its glass transition temperature and is therefore plastic and rubbery enough to be flexed as it is introduced through the percutaneous portal and into the intramedullary canal. Heating of the composite device 710 to reach the first thermo-chemical state may be accomplished by means including soaking the implant in a hot saline bath, application of ultrasonic vibratory energy, application of radiant heat energy, use of a local radiation emitter (including ultraviolet, visible light, and/or microwave energy), use of a laser energy emitter, use of inductive heat energy, electrical resistive heating of the cage or the delivery instrument, or heating of an expansion apparatus, among others.

The composite device 710 is inserted into the delivery tube 62, pushed through the tube and advanced into the intramedullary canal 2 until the composite device 710 is contained within the confines of the canal. Optionally, the composite device 710 may be inserted directly through the percutaneous portal 60 without passing through a delivery tube 62. A portion of the composite device 710 may be surrounded by a protective sheath 749, which is positioned so that it covers the device 710 at the point of the bone fracture. The device 710 is then expanded radially. As the support structure 711 expands, the stiffening rods 714, the cage 712 and thermoplastic matrix 716 move radially outward and are eventually aligned along the wall of the intramedullary canal, parallel to the longitudinal axis of the bone. The composite device 710 is allowed to cool to below the low glass transition temperature T_g , thus attaining the second thermo-chemical state, and the matrix 716 crystallizes. As the matrix crystallizes it conforms to the shape of the surrounding intramedullary canal, and the cage 712 and stiffening rods 714 are fixed in the thermoplastic matrix 716 along the wall of the canal. The shape of the intramedullary canal can vary along the length of the bone, with the canal being generally circular in the diaphysial region near the midpoint of the bone and irregular in the metaphysial regions near the ends of the bone. Although the thermoplastic matrix 716 is in a generally tubular shape as the composite device 710 is inserted, the thermoplastic qualities of the matrix allow it to conform to the shape of the intramedullary canal around it, and it crystallizes in that shape, thus providing torsional strength and support to the surrounding bone. The ability of the thermoplastic matrix 716 to conform to the irregularities in the intramedullary canal allows the device 710, and the stabilized bone, to withstand greater torsional forces than would a device with a constant circular shape which did not conform to the canal.

Deformation and/or radial expansion and of the composite device 710 to conform to the intramedullary canal can be accomplished in several ways. A deformation apparatus (such as those shown in FIGS. 16 and 17) may be introduced into the central core of the composite device 710 before or after it has been inserted into the intramedullary canal. The deformation apparatus is expanded, and forces expansion of the

composite device 710 until it fills the confines of the canal. The deformation apparatus may comprise a heat source to raise the temperature of the thermoplastic matrix 716. Alternatively, the cage 712 may be constructed with an outward spring bias, introduced into the intramedullary canal and allowed to expand. In another embodiment which is described in detail below, a balloon apparatus (such as that shown in FIG. 17) is introduced into the central core of the composite device 710. As the balloon is inflated with heated gas or liquid, it expands, and consequently induces expansion of the composite device 710. Once the device is expanded, the balloon can be deflated and removed. It is appreciated that these deformation and expansion techniques and apparatuses may also be employed with composite device 10 and other embodiments of intramedullary bone fixation devices disclosed herein.

Referring to FIG. 8, a longitudinal cross-section shows two composite devices 710, 750 implanted in a bone. Deploying two bone fixation devices nested in this manner may provide additional strength, rigidity and resistance to torsion than would be available from one bone fixation device. Twice the thermoplastic matrix material and twice the support structure are present to provide additional stabilization.

Composite device 750 comprises a thermoplastic matrix 756, which surrounds a support structure which includes a cage 752 and a plurality of rods 754. The configuration of matrix 756, cage 752 and rods 754 may be identical to that of composite device 710. Prior to implantation, the composite device 750 is partially radially expanded. The composite device 710 is contracted, and slid into a hollow central core 758 of the composite device 750. Together, the two devices 710, 750 are heated until the thermoplastic matrices 716, 756 reach the first thermo-chemical state. The two devices 710, 750 are introduced as a unit into the intramedullary canal. The inner disposed composite device 710 is expanded using one of the techniques previously described. As the inner composite device 710 expands, it pushes radially against the outer disposed composite device 750, forcing it to expand radially until it contacts and conforms to the wall of the surrounding intramedullary canal.

Alternatively, composite devices 710, 750 may be introduced individually into the intramedullary canal. Composite device 750 may be introduced first, heated and expanded. Composite device 710 is then introduced into the hollow central core 758 of composite device 750 after it is in the intramedullary canal. After both devices 710, 750 are in the canal, composite device 710 is heated and expanded, pushing radially against the outer composite device 750.

The thermoplastic matrix 716 surrounding the composite device 710 may contact and conform to the thermoplastic matrix 758 of the composite device 750. The two devices 710, 750 are allowed to cool to the second thermo-chemical state and harden.

Referring to FIGS. 9A-9C, three cross-sectional views along different parts of the bone depicted in FIG. 8 are shown, with devices 710, 750 implanted in the intramedullary canal. In FIG. 9A, the intramedullary canal 2 is relatively wide and circular in shape, resulting in a wide, circular central hollow core 718. Also, the thermoplastic matrices 716, 756 are relatively thin, and the rods 714, 754 are spaced relatively far apart, as the devices 710, 750 had to expand radially farther to contact the wall of the intramedullary canal at that point. As seen in FIG. 9B, at this point along the bone the intramedullary canal is smaller in diameter and more irregular in shape. The thermoplasticity of the matrices 716, 756 allows the devices 710, 750 to match the size and shape of the canal. As seen in FIG. 9C, at this point along the bone the intramedul-

lary canal is narrow in cross-section and substantially triangular in shape. Accordingly, the thermoplastic matrices **716**, **756** are thicker and the rods **714**, **754** are closer together, since the devices **710**, **750** are relatively less expanded.

Referring to FIG. **10**, an alternative embodiment of an intramedullary bone fixation composite device is shown in a cutaway view. Composite device **810** comprises support structure **811** and a thermo-chemically activated thermoplastic matrix **816**. Support structure **811** comprises a cage **812**, a plurality of rods **814**, and a plurality of sutures **815** which connect the cage to the rods. The thermo-chemically activated matrix **816** surrounds the cage **812**, rods **814** and sutures **815** such that they are embedded in the matrix. The sutures **815** are interwoven around and between the cage **812** and the rods **814** to connect the cage **812** to the rods **814** in a manner that allows regulated movement of the cage **812** and the rods **814** relative to one another.

Alternately, the sutures may be knit into a sleeve that holds the array of rods and surrounds the cage. The interweaving may be constructed in such a way as to allow radial expansion of the cage **812** and the rods **814** from a contracted position in which the cage **812** is lengthened and the rods **814** are tightly packed together, to an expanded position in which the cage **812** is shortened, radially expanded and the rods **814** are arrayed around the cage with relatively more space between each rod. The cage **812** may comprise web-like stent material similar to stents depicted in FIGS. **3A-3I**, or may comprise another woven or laser cut stent-like material. The rods **814** may be similar to the rods **14** depicted in FIG. **5**. The thermo-chemically activated thermoplastic matrix **816** may be similar to the thermo-chemically activated thermoplastic matrix **16** described previously and depicted in FIG. **6**. The sutures may comprise any of several commercially available sutures, including Dyneema Purity® Ultra High Molecular Weight Polyethylene (UHMWPE), or bioabsorbable multifilament polylactic acid (PLA) sutures such as PANACRL™, among others.

Composite device **810** may be introduced into the intramedullary canal in the same manner as previously described for composite device **710**. Energy is applied to composite device **810**, heating it until the thermo-chemically activated matrix **816** reaches the first thermo-chemical state, and is flexible and rubbery. The composite device **810** is contracted so that it is sufficiently flexible to be inserted into the intramedullary canal through an opening in the bone, an opening which may not be parallel to the intramedullary canal. The composite device **810** is inserted into the canal and expanded by one of the expansion methods previously described. When the device is expanded within the intramedullary canal, the thermo-chemically activated matrix **816** contacts and is conformed to the walls of the intramedullary canal. The device **810** is allowed to cool and the thermo-chemically activated matrix **816** attains the second thermo-chemical state, and hardens sufficiently to fix the support structure **811** in its expanded position within the intramedullary canal.

Referring to FIGS. **11A-11E**, a series of five cross-sectional views illustrate the expansion of composite device **810** from a contracted position to a fully expanded position. Beginning with FIG. **11A**, a hollow central core **818** of composite device **810** is substantially circular. As composite device **810** expands, the cage **812** and the hollow central core **818** increase in diameter and the thermoplastic matrix **816** stretches to fit around the cage **812**. At the most expanded state illustrated in FIG. **11E**, the thermoplastic matrix **816** is substantially thinner than at the most contracted state. In FIG. **11A**, the array of rods **814** are relatively closely packed near

one another; in FIG. **11E** they are spread apart and are substantially equidistantly arrayed about the hollow central core **818**.

FIGS. **12A-12E** illustrate an alternative embodiment of a composite device in five cross-sectional views. Similar to composite device **810**, composite device **910** comprises a support structure **911** with a cage **912**, a plurality of rods **914**, and a plurality of sutures **915** which connect the cage to the rods. A thermo-chemically activated thermoplastic matrix **916** surrounds the cage **912**, rods **914** and sutures **915** such that they are embedded in the matrix. As most clearly seen in FIG. **12C**, in this embodiment, the thermoplastic matrix **916** is configured in a series of folds **917**, as compared to the circular configuration seen for thermoplastic matrix **816** in FIG. **11C**. The folded configuration of the thermoplastic matrix **916** results in a star-shaped hollow central core **918**. The star-shaped hollow central core **918** is smaller in terms of cross-sectional open space, as much of the space is taken up by the folds of the thermoplastic matrix **916**. Therefore, the thermoplastic matrix **916** is thicker in this embodiment than in other embodiments such as device **810**. Thus, as seen in FIG. **12E**, the fully expanded composite device **910** has a thicker thermoplastic matrix, which may result in additional support for the surrounding bone during the healing process.

Composite device **910** may be introduced into the intramedullary canal in the same manner as previously described for composite devices **710** and **810**. Energy is applied to composite device **910**, heating it until the thermo-chemically activated matrix **916** reaches the first thermo-chemical state, and is flexible and rubbery. The composite device **910** is contracted into the deeply folded position seen in FIG. **12A**, so that it is sufficiently flexible to be inserted into the intramedullary canal through an opening in the bone. The composite device **910** is inserted into the canal and expanded by one of the expansion methods previously described. A specifically configured implant expander such as a star-shaped balloon expansion device (not shown) may be used to expand the device **910**. When the device is expanded within the intramedullary canal, the thermo-chemically activated matrix **916** contacts and is conformed to the walls of the intramedullary canal. The device **910** is allowed to cool and the thermo-chemically activated matrix **916** attains the second thermo-chemical state, and hardens sufficiently to fix the cage **912** and rods **914** in their expanded positions within the intramedullary canal. In the case of a larger bone, two composite devices **910** may be deployed, one inside the other, to provide additional support to the bone.

Referring to FIGS. **13A** and **13B**, one alternative embodiment of a support structure **71** suitable for use in an intramedullary bone fixation device has an hourglass shape. In the context of the present invention, an hourglass shape is a generally longitudinal, columnar shape in which the two end portions of the column are wider in diameter than a middle portion of the column. The support structure **71** comprises a cage **72** and rods **14**. In this embodiment, the diameters of cage ends **74**, **76** are greater than the diameter of a cage sleeve **78**. In order to clearly view the configuration of cage and rods, a thermoplastic matrix is not shown. A matrix similar to that of the thermoplastic matrix **16** of FIG. **1** may be used in conjunction with support structure **71**, or it may have a different configuration. The hourglass shape enables the tubular support structure **71** to conform to the contours of the intramedullary canal of a long bone, in which the metaphyseal regions at the ends of the bone are irregular and may be greater in diameter than the diaphyseal region near the midpoint of the bone. In the embodiment depicted, the hourglass shape is achieved by the particular threading of the rods

11

within the stent portion of the cage. At the first 74 and second 76 ends, the rods 14 are contained within the confines of the cage 72; toward the center of the sleeve 78, the cage is contained within the circle of the rods 14. In FIG. 13A, the support structure 71 is shown in the contracted state (for insertion or removal); in FIG. 13B, the expanded state is shown. The support structure 71 may be inserted in the same manner as described previous for support structure 11, and the same expansion methods described previously may be used to expand the support structure 71.

One alternative embodiment of an intramedullary bone fixation device (not shown) comprises a laser-cut cage which is constructed with an outward spring bias. In this embodiment, the device is compressed prior to implantation by holding the rods steady and pulling longitudinally on the cage. The web-like configuration of the cage permits the cage to lengthen while simultaneously its core diameter contracts, enabling the device to be narrow and flexible enough for insertion. The device is introduced into the intramedullary canal and the cage is released. Upon release, the outward spring bias of the cage causes the cage to expand radially and simultaneously shorten. Radial expansion continues until the outer perimeter of the device contacts the inner wall of the intramedullary canal. The web-like configuration of the cage also allows it to conform to variations in the geometry of the intramedullary canal. This embodiment may also include the thermoplastic matrix, wherein prior to the compression step described above, the thermoplastic matrix is heated to the first thermo-chemical state, so it is flexible as the device is compressed, inserted and expanded. After insertion and radial expansion, the energy is allowed to dissipate and the thermoplastic matrix attains the hardened second thermo-chemical state.

Referring to FIGS. 14A through 14D, another alternative embodiment of the invention comprises a cage with an outward spring bias, which may be used in conjunction with a thermoplastic matrix such as that depicted in FIGS. 1 and 6. FIG. 14A is a perspective view of a cage 112, cut with a plurality of accordion-type folds 114 which unfold as the cage expands radially. Alternating with the folds 114 are longitudinal ribs 116, and a hollow central core 115 extends the length of the cage 112. Each rib 116 has a longitudinal channel 118 which may hold a stiffening rod. The cage may be laser-cut or machined from metal, or may comprise a plastic material or a thermo-chemically activated thermoplastic matrix material, as described above. The cage 112 may have a straight shape with a constant diameter, or may have an hourglass shape in which the two ends are wider than the central section. Other shapes may alternatively be used for different bone morphologies.

FIG. 14B is an end view of the cage 112 in a compressed state, showing the tight compaction of the folds 114 and ribs 116. FIG. 14C is a perspective view of the cage 112 after radial expansion, and FIG. 14D is an end view of the expanded cage 112. In this embodiment, the support structure can be compressed for implantation by a binding material which is wrapped or tied around the compressed cage. After insertion into the intramedullary canal, the cage is released by cutting or removal of the binding material. Once released, the outward spring bias of the cage 112 causes the cage 112 to expand radially in the same manner as described for the previous embodiment.

In another embodiment the support structure may be monolithic; that is, formed as a single unit. The cage and rods are formed together, such as by a machining process and remain connected together. Referring to FIG. 15, an embodiment of a monolithic support structure 111 is shown in an

12

expanded state. This embodiment has no channels for rods, but consequently has ribs 117 between the accordion folds 114 which are solid and comprise more material, thus providing rigidity similar to the rods of other embodiments. Between the ribs 117, the accordion folds 114 have a plurality of slots 119. The slots 119 allow for less material and thus more flexibility of the support structure when compressed. Additionally, when compressed, the tight packing of the ribs 117 between the accordion folds 114 allows the support structure 111 to flex sufficiently for insertion into the intramedullary canal. The monolithic support structure 111 may be used in conjunction with a thermoplastic matrix. Contraction, insertion and expansion of the monolithic support structure 111 may be in the same manner as described previously for the cage 112.

In another embodiment of the invention, at least two support structures and/or cages such as those depicted in FIGS. 14 and 15 can be nested, one within the other. A first support structure 111 or cage 112 embedded in the thermoplastic matrix 16 is heated to the first thermo-chemical state, compressed, inserted into the intramedullary canal, and expanded. A second support structure 111 or cage 112 embedded in the thermoplastic matrix 16 is similarly compressed and inserted into the central core 115 of the first support structure. When the second structure 111 or cage 112 expands, it pushes radially against the first structure 111 or cage 112. As described previously for other embodiments, the thermoplastic matrix 16 surrounding the first support structure conforms to the contours of the intramedullary canal. Within the first support structure, the thermoplastic matrix 16 surrounding the second support structure conforms to the surrounding first support structure. The matrix material surrounding both the first and second structures cools to the second thermo-chemical state and crystallizes. This double layer of matrix material and support structures provides enhanced support and rigidity to the surrounding bone.

The cage 112 and support structure 111 embodiments depicted in FIGS. 14 and 15 can alternatively be constructed without an outward spring bias. The compressed cage 112 or support structure 111 may be surrounded by the thermoplastic matrix 16. As described previously, the device is heated so the thermo-plastic matrix 16 reaches the first thermo-chemical state and the device is flexed and inserted into the intramedullary canal. In this case, an expansion apparatus or balloon mechanism as previously described, or other expansion mechanism is inserted into the central core 115 and used to expand the device after it is implanted. Once the device is expanded, energy dissipates into the surrounding tissue, the matrix attains the second thermo-chemical state, and the cage 112 or support structure 111 is fixed within the cooled, crystallized matrix 16. The expansion apparatus, balloon mechanism, or other expansion mechanism may then be removed from the central core 115.

One alternative embodiment of an intramedullary bone fixation composite device (not shown) comprises a thermoplastic matrix which is not continuous along the entire length of the corresponding cage or support structure. In this embodiment, the matrix comprises at least two separate tube-like portions, each of which surrounds one end of the cage or support structure and extends partway along the sleeve. This discontinuous configuration of the matrix contributes to an hourglass shape and allows less matrix material to be used. This matrix configuration can be used with either a cage with an outward spring bias, or with a cage with no outward spring bias.

Another alternative embodiment of an intramedullary bone fixation composite device (not shown) comprises a support

structure which comprises at least one rod, and no cage. Prior to implantation, the matrix is heated to the first thermo-chemical state and formed into a tubular shape around the rods, which are subsequently embedded in the matrix. The device is flexed and inserted into the patient. While the matrix is still in the first thermo-chemical state, an expansion apparatus or balloon is inserted into the center of the tubular device and used to expand the device within the intramedullary canal. As the device expands, the rods and the matrix material are pushed radially to the inner wall of the intramedullary canal. After expansion, the device is allowed to cool to the second thermo-chemical state, and the matrix hardens, fixing the rods in their positions around the inner wall of the canal.

Another alternative embodiment of an intramedullary bone fixation device (not shown) comprises a support structure which comprises a cage manufactured of the thermoplastic matrix material, and rods. During manufacture the matrix material is heated above its T_g and extruded into a cage-like form. During or after extrusion the rods are interwoven, braided in, or otherwise attached as described previously. To implant the device, the device is heated above the T_g of the matrix to attain the first thermo-chemical state, contracted, flexed, inserted and expanded as described previously.

FIGS. 16A and 16B illustrate an implant expansion device which may be used to deform and expand several of the intramedullary bone fixation devices described previously, such as composite device 10, composite devices 710, 750 and 810, a device incorporating support structure 71, or other devices which incorporate a cage or support structure without an outward spring bias. A mechanical expansion apparatus 500 is longitudinally insertable into the central core of the intramedullary bone fixation device. As seen in FIG. 16A, the mechanical expansion apparatus 500 has a shaft 514, which extends from a first end 510 to a second end 512. An adjustment nut 516 is threaded onto a threaded portion 515 of the shaft 514, adjacent the first end 510. A cone-shaped first expander guide 518 is also threaded onto the threaded portion 515 of the shaft 514, on the opposite side of the adjustment nut 516 from the first end 510. The second end 512 of the shaft 514 terminates in a cone-shaped second expander guide 519. The shaft 514 comprises a metallic material, and is sufficiently thin and flexible to be inserted into the central core of an intramedullary bone fixation while the device is in the intramedullary canal of a bone in a patient.

Referring to FIG. 16B, strung on the central shaft 514 and listed in their order of occurrence from the first expander guide 518 to the second expander guide 519 are: a first expander segment 520, a plurality of core segments 522, a central segment 524, another plurality of core segments 522, and a second expander segment 526. The core segments 522 and the central segment 524 comprise a relatively rigid material, while the expander segments 520, 526 comprise a relatively rubbery, flexible material. The first expander segment 520 surrounds a portion of the first expander guide 518 in a sleeve-like manner, and the second expander segment 526 similarly surrounds a portion of the second expander guide 519 in a sleeve-like manner. The core segments 522, central segment 524, and expander segments 520, 526 are initially placed loosely on the shaft 514 with space between each segment, so that the apparatus can flex while being inserted into the central core of the intramedullary bone fixation device.

After the intramedullary bone fixation device with a thermoplastic matrix (not shown) is placed in the intramedullary canal, the mechanical expansion apparatus 500 may be inserted through the delivery tube 62 (not shown) into the central core of the intramedullary bone fixation device. Then

the adjustment nut 516 is turned, forcing the first expander guide 518 to advance along the shaft 514 toward the second expander guide 519 at the second end 512. The first expander segment 520, core segments 522, central segment 524, and second expander segment 526 are compressed together as they are held between the first and second expander guides 518, 519. The rubbery, flexible expander segments 520, 526 expand radially as they are forced farther onto the cone-shaped expander guides 518, 519. As the expander segments 520, 526 expand radially, they push the ends of the surrounding intramedullary bone fixation device outward radially, thus matching the generally hourglass shape of the intramedullary canal. Expansion is ceased when the outer perimeter of the intramedullary bone fixation device contacts the inner walls of the intramedullary canal. The expansion apparatus 500 may be kept in the central core of the intramedullary bone fixation device until the thermoplastic matrix cools to the second thermo-chemical state. The expansion apparatus 500 is contracted by turning the adjustment nut 516 in the opposite direction, and the apparatus 500 is then removed from the central core.

The expansion apparatus 500 may optionally include a heating element. In this configuration, it can heat the thermoplastic matrix of an intramedullary bone fixation device while in a patient, in order to adjust the conformity of the matrix within the intramedullary canal.

Referring to FIGS. 17-21, an alternative method to deform and expand an intramedullary bone fixation device comprises an implant deformer which is a balloon expansion apparatus. As seen in FIG. 17, a balloon expansion apparatus 600 configured to fit within a composite device 10 in the intramedullary canal of a bone comprises an elastic bladder 602 with an opening 604. A set of flexible hoses comprising an input hose 606 and an output hose 608 are configured to extend from a regulator apparatus 610, through the opening 604 and into the elastic bladder 602. The regulator apparatus 610 is external to the patient, and comprises a pump to regulate flow, and a temperature regulator to regulate the temperature, of liquid which can flow into and out of the elastic bladder 602. FIG. 17 depicts the hoses adjacent and parallel to one another; however they may be configured in alternative arrangements, including a concentric arrangement in which one hose surrounds the other. The hoses 606, 608 terminate at differing positions within the bladder 602.

Referring to FIG. 18, a composite device 710 with a balloon expansion apparatus 600 already inserted into the central core 718 is introduced into the intramedullary canal of a bone. Introduction into the bone can be through the method described previously, in which the composite device (with the balloon apparatus in the central core) is heated so that the matrix attains the first thermo-chemical state. The composite device 710 plus balloon apparatus 600 are flexed and introduced into the intramedullary canal through the percutaneous portal 60. A delivery tube 62 (not shown) may optionally be used during the introduction and expansion procedures. The input 606 and output 608 hoses are inserted through the balloon opening 604 ideally before the composite device 710 plus balloon apparatus 600 are introduced into the intramedullary canal, but can optionally be inserted into the balloon opening 604 after introduction into the intramedullary canal. A protective sheath 49 may surround the composite device 710 at the location of the bone fracture.

Referring to FIG. 19, after the composite device 10 plus balloon apparatus 600 are within the intramedullary canal, inflation of the bladder 602 may begin. The external regulator apparatus 610 (not shown) pumps heated liquid such as water or saline solution, among others, through the input hose 606

into the elastic bladder 602. The heat of the liquid maintains the thermoplastic matrix 716 of the composite device 710 at the deformable first thermo-chemical state. As the heated liquid fills the bladder 602, the bladder expands. Contained within the composite device 710, the bladder 602 eventually pushes outward, inducing radial expansion of the composite device 710. As described previously, cage and rod components of the support structure 711 are connected in a web-like construction which allows them to expand radially. The thermoplastic matrix 716 surrounding the support structure 711 is at the heated first thermo-chemical state and is pushed radially by the expanding support structure, conforming to the surrounding intramedullary canal walls. The flexible, rubbery character of the matrix allows it to fit into the natural morphological variations in the wall of the intramedullary canal. A mesh-like end cap 746 on a second end 732 of the composite device 710 prevents the elastic bladder 602 from escaping or ballooning out of the second end 732. The output hose 608, which terminates at a location different from that of the input hose 606, allows liquid to flow out of the balloon apparatus 600. The regulator apparatus 610 maintains the flow, temperature and pressure of the liquid.

FIGS. 20A-20C display cross-sections of the bone and the composite device 710 at three different locations along the length of the bone shown in FIG. 19. At cross-section A-A in FIG. 20A, the cross-sectional shape of the intramedullary canal is relatively circular. The device 710 has expanded to the wall of the canal, the matrix 716 is relatively thin, and the rods 714 are spaced relatively far apart. At cross-section B-B in FIG. 20B, the canal is smaller and more rectangular in shape than at cross-section A-A. However, the deformable nature of the matrix 716 allows the matrix and the entire composite device 710 to expand differentially and conform to this variation in shape of the intramedullary canal. At cross-section C-C in FIG. 20C, the cross-sectional shape of the intramedullary canal is relatively smaller, and has a triangle-like shape. Again, the matrix 716 and the composite device 710 can conform to this irregular shape. The rods 714 are relatively closer together and the matrix 716 is relatively thicker. The ability of the composite device 710 to closely conform to the confines of the intramedullary canal allows the device to withstand greater torsional forces than would a device with a constant circular shape which did not conform to the canal.

Referring to FIG. 21, the balloon expansion apparatus 600 is depicted being withdrawn from the composite device 710. After expansion of the elastic bladder 602 is accomplished as described previously, the liquid in the elastic bladder 602 may be cooled by pumping cool liquid in through input hose 606 and withdrawing warmer liquid through output hose 608 until a consistently cooler liquid is in the bladder 602. The cooler liquid in the bladder absorbs thermal energy from the matrix 716, allowing it to cool and transform from the flexible first thermo-chemical state to the hardened second thermo-chemical state. Once the composite device 710 has thus cooled and hardened, the remaining liquid may be pumped out of the elastic bladder 602, and the balloon expansion device 600 is pulled out of composite device 710 through the percutaneous portal 60.

A protective, tubular insertion sheath (not pictured) may surround all or a portion of any of the above-described intramedullary bone fixation devices during the implantation procedure, and may optionally be removed following implantation. The insertion sheath may be very thin, and may prevent portions of the support structure or matrix from snagging on or scratching the intramedullary canal, or portions of the fractured bone. Once the device is inserted, the sheath may be

removed by being pulling the sheath out through the delivery tube, while leaving the device behind.

With any embodiment of the device, after insertion of the device but before conclusion of the implantation procedure, x-ray, fluoroscopy, or other radiographic methods may be implemented to assess the alignment of the device relative to the bone. If alignment is unsatisfactory, a heating element (not shown) or a heatable expansion device such as the balloon apparatus 600 or mechanical expansion apparatus 500 as described previously may be introduced into the central core. The device is heated so the thermoplastic matrix again reaches first thermo-chemical state, and the device may then be removed and reinserted or otherwise adjusted until a satisfactory alignment is achieved. The device is allowed to cool, so the thermoplastic matrix returns to the second thermo-chemical state through the natural dissipation of energy into the surrounding tissue.

Post-implantation, the device may be removed if desired. The method of removal will vary, depending on the state of the decomposition of the biocompatible thermoplastic matrix. If the thermoplastic matrix is still intact, a percutaneous portal may be opened and a tube may be inserted. The tube may be the same as or similar to the delivery tube 62 described previously. A heating element or heatable expansion apparatus such as the mechanical expansion apparatus 500 or balloon expansion apparatus 600 is introduced into the central core, and the device is heated until the matrix reaches the first thermo-chemical state, above the glass transition temperature. The heat source is removed; the device may be contracted by holding the rods steady and pulling longitudinally on the cage. The device may be removed through the delivery tube, or directly through the percutaneous portal. If the thermoplastic matrix has been sufficiently absorbed so that it is no longer intact, no heating is required; the device is contracted and removed.

Another embodiment of the invention (not shown) comprises a support structure and an alternative form of the thermoplastic matrix, comprising an injectable form of a synthetic biodegradable polymer, poly-D,L-lactic acid-polyethyleneglycol (PLA-PEG). This biodegradable composite is temperature-sensitive so that when it is heated it takes on a liquid, semi-solid form and following injection, cools and becomes semi-solid. A structure such as support structure 11, 711, 811 or 71 is introduced into the intramedullary canal. The structure may have a protective sheath surrounding the portion of the structure which will be adjacent to the fracture location. Following insertion of the support structure into the intramedullary canal, and radial expansion of the support structure, heated PLA-PEG is injected through a flexible tube or catheter which is inserted through the delivery tube 62 into the central core. The liquid PLA-PEG flows through the web-like support structure, filling the canal and surrounding the support structure. The protective sheath prevents the PLA-PEG from contacting the fractured area of the bone. The PLA-PEG is allowed to cool and harden, and provides rigid support around the structure.

Referring to FIG. 22A, a perspective view shows another embodiment of the invention, comprising a telescoping intramedullary fixation device 210. This device comprises a central wire 212 surrounded by a series of five tubular nesting components 213-217. Each tubular nesting component is substantially the length of the entire device 210 when all components are nested together, and each successive nesting component is slightly wider in diameter than the component it surrounds. Other embodiments of the telescoping intramedullary fixation device 210 may have fewer, or more, than five nesting components. The central wire 212 may have a solid

core and may not be tubular, but is slender and thus sufficiently flexible to be inserted into the intramedullary canal. The nesting components **213-217** may comprise metal, a biocompatible polymer material, or a mesh-like stent material (such as those depicted in FIG. 3), and may be embedded in a thermoplastic matrix material. FIG. 22A displays the telescoping device **210** in a fully extended or telescoped position; however when completely implanted in a patient the device **210** is in a collapsed position in which the nesting components are concentrically nested together.

The first nesting component **213** surrounding the central wire **212** is slightly wider in diameter than the central wire **212**. Each successive nesting component **214-217** is slightly wider than the preceding one, and as the nesting components increase in diameter, the width of the wall of the component may decrease so that each nesting component is still flexible enough to be inserted into the canal. The wall thickness of each of the nesting components **213-217** may advantageously be selected such that the nesting components **213-217** are all nearly equally flexible. According to one alternative embodiment (not shown), the nesting components do not have solid walls but have slots in the walls to increase flexibility.

In a patient, the central wire **212** may first be inserted into the intramedullary canal. Then, successive nesting components **213-217** with increasing diameters are introduced into the intramedullary canal. The nesting component **213** with the smallest diameter is slid in around the central wire **212**; the nesting component **214** with the next largest diameter is slid in surrounding the first nesting component **213**, and the remaining nesting components **215-217** are inserted in a similar fashion. The largest nesting component **217** fits just inside the walls of the canal. After the components are inserted and collapsed together, an injectable, hardenable polymer such as bone cement or a biocompatible polymer such as PLA-PEG may be introduced into the canal to fill any spaces between the largest nesting component **217** and the wall of the canal. The largest nesting component **217** may have a sheath **219** which prevents the polymer from accessing the fractured area of the bone, as described previously. The nested set of nesting components **213-217** has a combined strength and rigidity which exceeds that of any of the individual nesting components, and the device **210** provides strength and support during bone healing.

FIG. 22B is an enlarged, stylized cross-sectional view of the connection between nesting components **216** and **217**; however the figure is representative of the connections between each of the nesting components **213-217**. Nesting component **217** has a first end **230** with an inward-projecting first lip **234**. The next smallest nesting component **216** has a second end **232** with an outward-projecting second lip **236**. The projecting lips **234**, **236** allow for easy removal of the apparatus. During removal, initially a slap hammer is used to break the largest nesting component **217** away from the bone cement. Nesting component **217** is pulled out first, and its inwardly-projecting lip **234** hooks the outwardly-projecting lip **236** of the next largest nesting component **216**, and causes it to be pulled out next, followed by the next largest nesting component **215**, until all the nesting components **213-217** are pulled out. The central wire **212** is removed separately after all the nesting components are removed.

Referring to FIG. 23, another embodiment of a telescoping fixation device is shown in an extended state. In this embodiment, telescoping fixation device **310** comprises a series of nesting components **313-317**, each of which comprises a mesh-like stent portion embedded in thermo-plastic matrix material **318** similar to that of the thermoplastic matrix **16** of FIGS. 1 and 6. Each nesting component **313-317** is substan-

tially the length of the entire device **310** when all components are nested together. Prior to implantation, the device **310** is heated as described previously so that the thermoplastic matrix material **318** reaches the first thermo-chemical state, and is rubbery and flexible. The device **310** is telescoped out into an extended configuration, and introduced into the intramedullary canal through an opening transverse to the longitudinal axis of the bone. The central wire **312** is introduced first, and the adjacent and smallest nested component **313** is inserted so it nests around the central wire. The next smallest nested component **314** is nested about the smallest nested component **313**, and so on until all the remaining nested components **315-317** are introduced into the intramedullary canal and nested together. The device **310** is allowed to cool so that energy dissipates into the surrounding tissue, and the thermoplastic matrix material **318** of each nesting component **313-317** reaches the second thermo-chemical state, and hardens.

Referring to FIG. 24, another alternate embodiment of a telescoping fixation device is shown, in a partially extended state. In this embodiment, telescoping fixation device **410** comprises a series of nesting components **413-417**, which are helically threaded so that during implantation each nesting component is threaded onto the preceding smaller component. The direction of the threading on each nesting component may alternate, so that each nesting component is threaded onto the next nesting component in the opposite direction from the previous one. Each nesting component **413-417** is substantially the length of the entire device **410** when all components are nested together. As with devices **210** and **310**, five nesting components are described, however in alternate embodiments the number and size of the nesting components may vary.

Similar to the telescoping fixation devices **210** and **310**, device **410** has a central wire **412** which is initially inserted into the intramedullary canal through a delivery tube **62** or similar interface. The first nesting component **413** is slid in around the central wire. The first nesting component **413** is tubular in form has a clockwise helical protrusion **420** which protrudes on the outside of the tube, winding in a clockwise direction along the length of the nesting component **413**.

Referring to FIGS. 25A-25B, two adjacent helically threaded nesting components have threading configurations which wind in opposite directions. As seen in FIG. 25A, the second nesting component **414** has a clockwise helical slot **422** which winds clockwise along its length, and a counter-clockwise helical protrusion **421** which winds counter-clockwise along its length. As nesting component **414** is inserted into the intramedullary canal, it is twisted clockwise so that its clockwise helical slot **422** fits over the clockwise helical protrusion **420** on the first nesting component **413**. As seen in FIG. 25B, the third nesting component **415** has a counter-clockwise helical slot **423**, and a clockwise helical protrusion **420**. It is inserted and threaded onto the second nesting component **414** in a counter-clockwise fashion, so that its counter-clockwise helical slot **423** engages with the counter-clockwise helical protrusion **421** on the second nesting component **414**. Each remaining nesting component is threaded clockwise or counter-clockwise to engage with the smaller component nested inside of it. The outermost nesting component **417** may or may not have a helical protrusion.

The helical threading system varies in direction so that the entire device will not be loosened when the outermost component **417** is turned in one direction. In addition, this bi-directional threading system adds overall torsional strength to

the telescoping fixation device **410**, since a twisting force in one direction will not disengage all the threading on the nesting components.

The telescoping fixation device **410** may be used in conjunction with an injectable hardenable polymer, such as bone cement or a biocompatible polymer such as PLA-PEG, among others. The fixation device **410** may be implanted as described previously, and the injectable polymer may then be injected into the intramedullary canal around the periphery of the device, to fix the device in place. The outermost nesting component **417** may have a protective sheath **419** which prevents the polymer from accessing the fractured area of the bone, as described previously. Removal of the device **410** is accomplished by breaking the device away from the polymer as described previously, then unthreading and removing each component **413-417** in a clockwise or counter-clockwise direction, beginning with the outermost component **417** and proceeding inward.

The present invention may be embodied in other specific forms without departing from its spirit or essential characteristics. It is appreciated that various features of the above-described examples can be mixed and matched to form a variety of other alternatives. For example, support structure and matrix materials and configuration features can vary, as can the method used to expand the device. As such, the described embodiments are to be considered in all respects only as illustrative and not restrictive. The scope of the invention is, therefore, indicated by the appended claims rather than by the foregoing description. All changes which come within the meaning and range of equivalency of the claims are to be embraced within their scope.

The invention claimed is:

1. A system for stabilizing a fractured bone having an intramedullary canal, the system comprising:

an implant shaped to be inserted into the intramedullary canal of the bone, the implant comprising a composite structure having a support structure covered by a thermo-chemically activated polymer matrix, a glass transition temperature of the thermo-chemically activated polymer matrix being greater than 37 degrees Celsius, a first thermo-chemical state above the glass transition temperature where the thermo-chemically activated polymer matrix is deformable, a second thermo-chemical state below the glass transition temperature where the thermo-chemically activated polymer matrix is relatively rigid, the thermo-chemically activated polymer being responsive to heating above the glass transition temperature to transform from the second thermo-chemical state to the first thermo-chemical state and responsive to cooling below the glass transition temperature to transform from the first thermo-chemical state to the second thermo-chemical state, the thermo-chemically activated polymer permitting multiple transitions between the first thermo-chemical state and the second thermo-chemical state, the composite structure, while the polymer is in the first thermo-chemical state, being responsive to a deforming force to expand from a first shape to a second shape which conforms to a form of a surrounding portion of the intramedullary canal, and the composite structure, while the polymer is in the second thermo-chemical state, maintaining the second shape in a relatively rigid configuration to provide torsional, axial, and bending reinforcement to the fractured bone sufficient to promote healing of the fractured bone; and

an implant deformer removably insertable into the implant and configured to transform the implant between the first

shape and the second shape within the intramedullary canal with a controlled transfer of thermal energy between the implant deformer and the polymer matrix; wherein the implant is configured to remain at the second shape after removal of the implant deformer from the intramedullary canal.

2. The system of claim **1**, wherein the support structure comprises at least one stiffening rod and a stent portion and the thermo-chemically activated polymer matrix is configured to stretch to fit around the stent portion and is substantially thinner at the second thermo-chemical state than at the first thermo-chemical state.

3. The system of claim **2**, wherein the support structure comprises an elongated shape having a longitudinal axis, wherein the implant is capable of radial expansion from a contracted state into an expanded state, wherein the support structure is further capable of greater flexion about the longitudinal axis while in the contracted state than while in the expanded state.

4. The system of claim **1**, wherein the implant deformer has an elongated shape and is capable of radial expansion within the implant to induce expansion of the implant.

5. The system of claim **1**, wherein the implant deformer comprises a balloon shaped to expand within the implant.

6. The system of claim **5**, wherein the implant deformer further comprises:

a plurality of hoses connectable to the balloon to convey liquid to and from the balloon;

a pump connectable to the hoses to regulate flow of the liquid through the hoses; and

a temperature regulator configured to control a temperature of the liquid.

7. The system of claim **1**, wherein the implant deformer comprises a mechanical expansion apparatus comprising a first end, a second end, a shaft, at least one cone-shaped portion, and a plurality of expandable segments situated between the first end and the second end, wherein the expandable segments are expanded by axial compression along the shaft between the first end and the second end.

8. A system for stabilizing a fractured bone having an intramedullary canal, the system comprising:

a thermo-chemically activated implant shaped to be inserted into an intramedullary canal of the bone, wherein the implant comprises a support structure and a thermo-chemically activated polymer matrix, a glass transition temperature of the thermo-chemically activated polymer matrix being greater than 37 degrees Celsius, a first thermo-chemical state above the glass transition temperature where the thermo-chemically activated polymer matrix is deformable, a second thermo-chemical state below the glass transition temperature where the thermo-chemically activated polymer matrix is relatively rigid, the thermo-chemically activated polymer being responsive to heating above the glass transition temperature to transform from the second thermo-chemical state to the first thermo-chemical state and responsive to cooling below the glass transition temperature to transform from the first thermo-chemical state to the second thermo-chemical state, the thermo-chemically activated polymer permitting multiple transitions between the first thermo-chemical state and the second thermo-chemical state, the polymer matrix, while the polymer is in the first thermo-chemical state, being responsive to a deforming force to expand from a first shape to a second shape which conforms to a form of a surrounding portion of the intramedullary canal, and the polymer matrix, while the polymer is in the second

thermo-chemical state, maintaining the second shape in a relatively rigid configuration to provide torsional, axial, and bending reinforcement to the fractured bone sufficient to promote healing of the fractured bone, the support structure comprising a cage and at least one stiffening rod, the cage comprising a sleeve comprising a web-like stent portion, the polymer matrix being sufficiently deformable to conform to a bone at a first thermo-chemical state and sufficiently hardened to stabilize the bone at a second thermo-chemical state; and an implant deformer removably insertable into the thermo-chemically activated implant and configured to induce expansion of the thermo-chemically activated implant within the intramedullary canal so as to transform the implant between the first shape and the second shape within the intramedullary canal with a controlled transfer of thermal energy between the implant deformer and the polymer matrix;

wherein the implant deformer is configured to transfer thermal energy to or receive thermal energy from the thermo-chemically activated implant to help control activation of the thermo-chemically activated implant.

9. The system of claim **8**, wherein the thermo-chemically activated implant is sufficiently deformable to conform to the intramedullary canal of the bone at a first thermo-chemical state and sufficiently hardened to stabilize the bone at a second thermo-chemical state.

10. The system of claim **8**, wherein the implant deformer has an elongated shape and is capable of radial expansion within the thermo-chemically activated implant to induce expansion of the thermo-chemically activated implant.

11. The system of claim **8**, wherein the implant deformer comprises a balloon shaped to expand within the thermo-chemically activated implant.

12. The system of claim **11**, wherein the implant deformer further comprises:

- a plurality of hoses connectable to the balloon to convey liquid to and from the balloon;
- a pump connectable to the hoses to regulate flow of the liquid through the hoses; and
- a temperature regulator configured to control a temperature of the liquid.

13. The system of claim **8**, wherein the implant deformer comprises a first end, a second end, and a plurality of expandable segments situated between the first end and the second end, wherein the expandable segments are expanded by axial compression between the first end and the second end.

14. A method for stabilizing a fractured bone having an intramedullary canal, the method comprising:

- inserting an implant into an intramedullary canal of the bone, wherein the implant comprises a support structure and a thermo-chemically activated polymer matrix, a glass transition temperature of the thermo-chemically activated polymer matrix being greater than 37 degrees Celsius, a first thermo-chemical state above the glass transition temperature where the thermo-chemically activated polymer matrix is deformable, a second thermo-chemical state below the glass transition temperature where the thermo-chemically activated polymer matrix is relatively rigid, the thermo-chemically activated polymer being responsive to heating above the glass transition temperature to transform from the second thermo-chemical state to the first thermo-chemical state and responsive to cooling below the glass transition temperature to transform from the first thermo-chemical state to the second thermo-chemical state, the thermo-chemically activated polymer permitting multiple tran-

sitions between the first thermo-chemical state and the second thermo-chemical state, the polymer matrix, while the polymer is in the first thermo-chemical state, being responsive to a deforming force to expand from a first shape to a second shape which conforms to a form of a surrounding portion of the intramedullary canal, and the polymer matrix, while the polymer is in the second thermo-chemical state, maintaining the second shape in a relatively rigid configuration to provide torsional, axial, and bending reinforcement to the fractured bone sufficient to promote healing of the fractured bone, the support structure comprising a cage and at least one stiffening rod, the cage comprising a sleeve comprising a web-like stent portion, the polymer matrix being sufficiently deformable to conform to a bone at a first thermo-chemical state and sufficiently hardened to stabilize the bone at a second thermo-chemical state;

inserting an implant deformer into the implant; expanding the implant deformer to transform the implant from the first shape to the second shape; and removing the implant deformer from the intramedullary canal;

wherein, after removal of the implant deformer from the intramedullary canal, the implant remains at the second shape.

15. The method of claim **14**, wherein transforming the implant to a second shape further comprises deforming the implant to conform to the shape of the intramedullary canal.

16. The method of claim **14**, wherein the wherein expanding the implant deformer further comprises inflating a balloon within the implant.

17. The method of claim **16**, wherein inflating the balloon within the implant comprises connecting a pump via hoses to the balloon, and operating the pump to regulate the flow of a liquid through the hoses into and out of the balloon.

18. The method of claim **14**, wherein the implant deformer comprises a first end, a second end, and a plurality of expandable segments situated between the first end and the second end, wherein expanding the implant deformer further comprises axially compressing the first end toward the second end to induce expansion of the expandable segments.

19. A method for stabilizing a fractured bone having an intramedullary canal, comprising:

- inserting a thermo-chemically activated implant into an intramedullary canal of the bone, wherein the implant comprises a support structure and a thermo-chemically activated polymer matrix, a glass transition temperature of the thermo-chemically activated polymer implant being greater than 37 degrees Celsius, a first thermo-chemical state above the glass transition temperature where the thermo-chemically activated polymer implant is deformable, a second thermo-chemical state below the glass transition temperature where the thermo-chemically activated polymer implant is relatively rigid, the thermo-chemically activated polymer being responsive to heating above the glass transition temperature to transform from the second thermo-chemical state to the first thermo-chemical state and responsive to cooling below the glass transition temperature to transform from the first thermo-chemical state to the second thermo-chemical state, the thermo-chemically activated polymer permitting multiple transitions between the first thermo-chemical state and the second thermo-chemical state, the polymer matrix, while the polymer is in the first thermo-chemical state, being responsive to a deforming force to expand from a first shape to a second shape which conforms to a form of a surrounding portion of the

23

intramedullary canal, and the polymer matrix, while the polymer is in the second thermo-chemical state, maintaining the second shape in a relatively rigid configuration to provide torsional, axial, and bending reinforcement to the fractured bone sufficient to promote healing of the fractured bone;

expanding an implant deformer to induce expansion of the thermo-chemically activated implant within the intramedullary canal so as to transform the implant between the first shape and the second shape within the intramedullary canal; and

transferring thermal energy between the implant deformer and the thermo-chemically activated implant to transform the thermo-chemically activated implant from a first thermo-chemical state to a second thermo-chemical state to increase rigidity of the thermo-chemically activated implant within the intramedullary canal, wherein the implant comprises a support structure and a thermo-chemically activated polymer implant, the support structure comprising a cage and at least one stiffening rod, the cage comprising a sleeve comprising a web-like stent portion, the polymer matrix being sufficiently deformable to conform to a bone at said first thermo-chemical state and sufficiently hardened to stabilize the bone at said second thermo-chemical state.

20. The method of claim 19, further comprising inserting the implant deformer into the thermo-chemically activated implant after insertion of the thermo-chemically activated implant into the intramedullary canal.

21. The method of claim 19, further comprising deforming the thermo-chemically activated implant at the first thermo-chemical state to conform to the shape of the intramedullary canal.

24

22. The method of claim 19, wherein transferring thermal energy between the implant deformer and the thermo-chemically activated implant comprises absorbing thermal energy from the thermo-chemically activated implant with the implant deformer.

23. The method of claim 19, further comprising transmitting heat to the thermo-chemically activated implant to transform it from the second thermo-chemical state to the first thermo-chemical state prior to insertion of the thermo-chemically activated implant into the intramedullary canal of the bone.

24. The method of claim 19, wherein expanding the implant deformer further comprises inflating a balloon within the thermo-chemically activated implant.

25. The method of claim 24, wherein transferring thermal energy between the implant deformer and the thermo-chemically activated implant comprises connecting a pump and a temperature regulator via hoses to the balloon, cooling a liquid, and operating the pump to regulate the flow of the cooled liquid through the hoses into and out of the balloon, the balloon absorbing the thermal energy from the thermo-chemically activated implant.

26. The method of claim 19, wherein the implant deformer comprises a first end, a second end, and a plurality of expandable segments situated between the first end and the second end, wherein expanding the implant deformer further comprises axially compressing the first end toward the second end to induce expansion of the expandable segments.

* * * * *