



US008079888B2

(12) **United States Patent**
Arias

(10) **Patent No.:** **US 8,079,888 B2**
(45) **Date of Patent:** ***Dec. 20, 2011**

(54) **COLLAPSIBLE FLOTATION DEVICE**

(75) Inventor: **David A. Arias**, Virginia Beach, VA (US)

(73) Assignee: **Kelsyus, LLC**, Virginia Beach, VA (US)

(*) Notice: Subject to any disclaimer, the term of this patent is extended or adjusted under 35 U.S.C. 154(b) by 0 days.

This patent is subject to a terminal disclaimer.

(21) Appl. No.: **12/890,240**

(22) Filed: **Sep. 24, 2010**

(65) **Prior Publication Data**

US 2011/0014831 A1 Jan. 20, 2011

Related U.S. Application Data

(63) Continuation of application No. 12/400,214, filed on Mar. 9, 2009, now Pat. No. 7,811,145, which is a continuation of application No. 12/028,227, filed on Feb. 8, 2008, now Pat. No. 7,500,893, which is a continuation of application No. 11/554,197, filed on Oct. 30, 2006, now Pat. No. 7,335,080, which is a continuation of application No. 11/143,703, filed on Jun. 3, 2005, now Pat. No. 7,134,930, which is a continuation of application No. 10/847,339, filed on May 18, 2004, now Pat. No. 7,147,528, which is a continuation of application No. 10/295,906, filed on Nov. 18, 2002, now Pat. No. 7,097,524, which is a continuation of application No. 09/772,739, filed on Jan. 30, 2001, now Pat. No. 6,485,344.

(60) Provisional application No. 60/238,988, filed on Oct. 10, 2000.

(51) **Int. Cl.**
B63C 9/08

(2006.01)

(52) **U.S. Cl.** **441/129**

(58) **Field of Classification Search** 441/129
See application file for complete search history.

(56) **References Cited**

U.S. PATENT DOCUMENTS

722,801 A	3/1903	Bourne, Jr.	
772,690 A	10/1904	Baswitz	
856,279 A	6/1907	Moore	
1,190,743 A	7/1916	Fageol	
1,479,903 A	1/1924	Erland	
1,960,474 A *	5/1934	Browne	441/129
2,119,023 A	5/1938	Pickard	
2,173,963 A	9/1939	Eubank	
2,190,566 A	2/1940	Julian	
2,207,025 A	7/1940	Rison	
2,334,924 A	11/1943	Hansen	
2,344,010 A	3/1944	Walsh	
2,357,789 A	9/1944	Levy	
2,360,715 A	10/1944	Perry	
2,420,344 A	5/1947	Alexander	
2,442,105 A	5/1948	Vacheron	

(Continued)

OTHER PUBLICATIONS

Swimways Corp., v. Overbreak, LLC, Order, Case No. 1:04cv627, dated Jan. 18, 2005.

(Continued)

Primary Examiner — Stephen Avila

(57) **ABSTRACT**

A device comprises a spring and a sleeve. The spring is configured to form a closed loop. The spring is moveable between a coiled configuration when the spring is collapsed and an uncoiled configuration when the spring is expanded. The spring defines a circumference while in the uncoiled configuration. The spring is disposed within the sleeve.

23 Claims, 5 Drawing Sheets

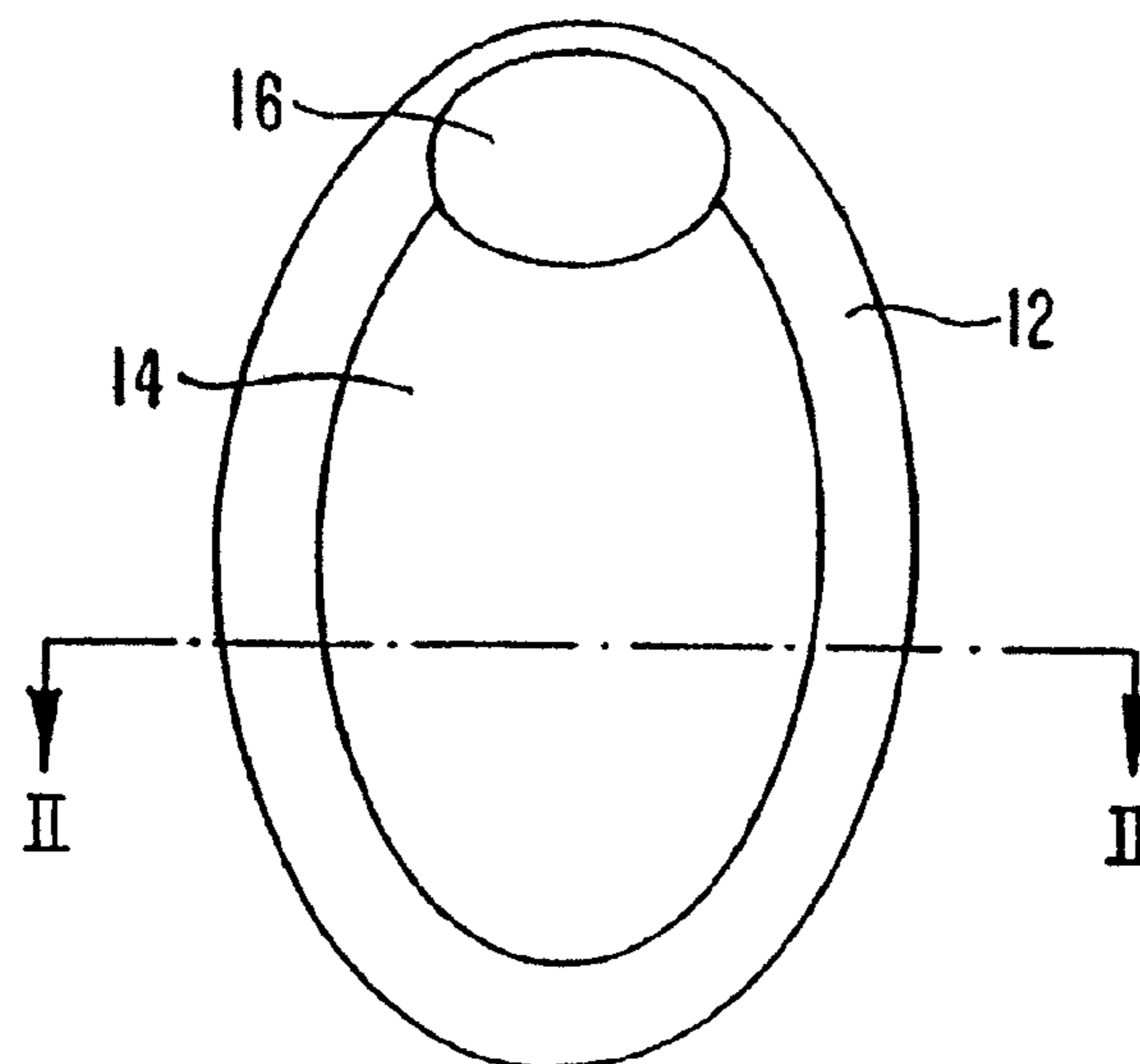

U.S. PATENT DOCUMENTS

2,637,861 A 5/1953 Kethledge
 2,731,997 A 1/1956 Muth et al.
 2,803,291 A 8/1957 Meyer
 2,803,839 A 8/1957 Mosley
 2,953,184 A 9/1960 Erstad
 3,052,895 A 9/1962 Lo Vico
 3,336,610 A 8/1967 Geddings
 3,339,218 A 9/1967 Stamberger
 3,602,930 A 9/1971 Channon
 3,775,782 A 12/1973 Rice et al.
 3,842,454 A 10/1974 Young
 3,860,976 A 1/1975 Suyama
 3,862,876 A 1/1975 Graves
 3,960,161 A 6/1976 Norman
 3,990,463 A 11/1976 Norman
 4,097,944 A 7/1978 Yulish
 4,200,942 A 5/1980 Case
 4,231,125 A 11/1980 Tittl
 D261,464 S 10/1981 Smith
 4,296,788 A 10/1981 Slater
 4,435,236 A 3/1984 Inae et al.
 4,478,587 A 10/1984 Mackal
 4,512,049 A 4/1985 Henry
 4,561,480 A 12/1985 Underwood et al.
 4,576,375 A 3/1986 Roberts
 4,693,691 A * 9/1987 DeYoe 441/129
 4,709,430 A 12/1987 Nicoll
 4,766,918 A 8/1988 Oderkirk
 4,815,784 A 3/1989 Zheng
 4,825,892 A 5/1989 Norman
 4,858,634 A 8/1989 McLeese
 4,861,300 A 8/1989 Casagrande et al.
 4,942,838 A 7/1990 Boyer et al.
 4,944,707 A 7/1990 Silverglate
 4,946,067 A 8/1990 Kelsall
 4,951,333 A 8/1990 Kaiser et al.
 4,976,642 A 12/1990 Wilkie
 4,986,781 A 1/1991 Smith
 5,024,262 A 6/1991 Huang
 5,038,812 A 8/1991 Norman
 5,045,011 A 9/1991 Lovik
 5,056,172 A 10/1991 Kaiser et al.
 5,059,463 A 10/1991 Peters
 5,070,807 A 12/1991 Lewis
 5,088,723 A 2/1992 Simmons
 D325,489 S 4/1992 Pratt
 5,116,273 A * 5/1992 Chan 160/370.21
 5,123,869 A 6/1992 Schipmann
 D328,324 S 7/1992 Wang
 5,163,192 A 11/1992 Watson
 5,163,461 A 11/1992 Ivanovich et al.
 5,186,667 A 2/1993 Wang
 5,206,964 A * 5/1993 Wilson, Sr. 5/417
 5,213,147 A 5/1993 Zheng
 5,261,131 A 11/1993 Kilby
 5,299,331 A 4/1994 Badillo
 D349,593 S 8/1994 Hensley
 5,334,067 A 8/1994 Henry et al.
 5,345,627 A 9/1994 Cammarata
 5,358,440 A 10/1994 Zheng
 5,385,518 A 1/1995 Turner
 5,396,917 A 3/1995 Hazinski et al.
 5,430,980 A 7/1995 Ferrier
 5,433,433 A 7/1995 Armell
 5,435,025 A 7/1995 Gerard et al.
 5,454,643 A 10/1995 Sullivan
 5,467,794 A 11/1995 Zheng
 D366,177 S 1/1996 Dean
 5,520,561 A * 5/1996 Langenohl 441/129
 5,533,653 A 7/1996 Kaufman
 5,560,385 A 10/1996 Zheng
 5,571,036 A 11/1996 Hannigan
 5,579,799 A 12/1996 Zheng
 5,592,961 A 1/1997 Chin
 D378,772 S 4/1997 Hall

5,618,110 A 4/1997 Sullivan
 5,618,246 A 4/1997 Zheng
 5,619,759 A 4/1997 Hansen et al.
 RE35,571 E 7/1997 McLeese
 5,644,807 A 7/1997 Battistella
 5,688,052 A 11/1997 Compton
 5,693,398 A 12/1997 Granger
 D389,362 S 1/1998 Boulatian
 5,718,612 A 2/1998 Elsholz
 5,729,846 A 3/1998 Sullivan
 5,730,529 A 3/1998 Fritz et al.
 5,810,695 A 9/1998 Sass
 D400,749 S 11/1998 Bechtold, Jr.
 5,885,123 A 3/1999 Clifford
 5,976,023 A 11/1999 Cho
 6,030,300 A 2/2000 Zheng
 D425,357 S 5/2000 Waring
 D426,415 S 6/2000 Le Gette et al.
 6,073,283 A 6/2000 Zheng
 6,113,453 A 9/2000 Stuffelbeam
 6,170,100 B1 1/2001 Le Gette et al.
 6,192,635 B1 2/2001 Zheng
 6,223,673 B1 5/2001 Mears et al.
 6,225,940 B1 5/2001 Ohlsen
 6,276,979 B1 8/2001 Saltel et al.
 D447,661 S 9/2001 Le Gette et al.
 D449,193 S 10/2001 Le Gette et al.
 6,343,391 B1 2/2002 Le Gette et al.
 6,478,038 B1 11/2002 Le Gette et al.
 6,485,344 B2 11/2002 Arias
 6,634,040 B2 * 10/2003 Le Gette et al. 5/417
 7,097,524 B2 8/2006 Arias
 7,134,930 B2 11/2006 Arias
 7,147,528 B2 12/2006 Arias
 7,335,080 B2 2/2008 Arias
 2003/0068940 A1 4/2003 Arias

OTHER PUBLICATIONS

Swimways Corp., v. Overbreak, LLC, Memorandum Opinion, Case No. 1:04cv627, dated Jan. 21, 2005.
 Merriam-Websters Collegiate Dictionary (10th ed. 1998) pp. 190, 337, 598.
 "How to Fold a Bicycle Tire," <http://www.rideyourbike.com/tirefold.html>, pp. 1-2, Aug. 2005.
 Office Action in Australian Patent Application No. 2002213464, mailed on May 26, 2005; 2 pages.
 Office Action in Canadian Patent Application No. 2,425,348, mailed on Aug. 7, 2006; 2 pages.
 Office Action in Chinese Patent Application No. 01819143.6, mailed on Feb. 17, 2006; 9 pages.
 Office Action in Chinese Patent Application No. 01819143.6, mailed on Aug. 18, 2006; 5 pages.
 Office Action in Chinese Patent Application No. 01819143.6, mailed on Feb. 27, 2009; 5 pages.
 Office Action in Chinese Patent Application No. 01819143.6, mailed on Jul. 3, 2009; 6 pages.
 Office Action in European Patent Application No. 01 981 847.5, mailed on May 17, 2006; 3 pages.
 Office Action in Japanese Patent Application No. 2002-534140, mailed on Jan. 15, 2007; 2 pages.
 Office Action in Japanese Patent Application No. 2002-534140, mailed on Jan. 15, 2008; 2 pages.
 Office Action in Mexican Patent Application No. PA/a/2003/002949 PCT, mailed on Mar. 7, 2006; 3 pages.
 Office Action in Australian Patent Application No. 2006202846, mailed on Apr. 7, 2009; 2 pages.
 Office Action in Japanese Patent Application No. 2008-127246, mailed on Jan. 17, 2011, 2 pages.
 Office Action for Chinese Patent Application No. 201010003813.8; mailed on Aug. 29, 2011.
 US 2,807,464, 01/1959, Lalick (withdrawn)

* cited by examiner

FIG. 1

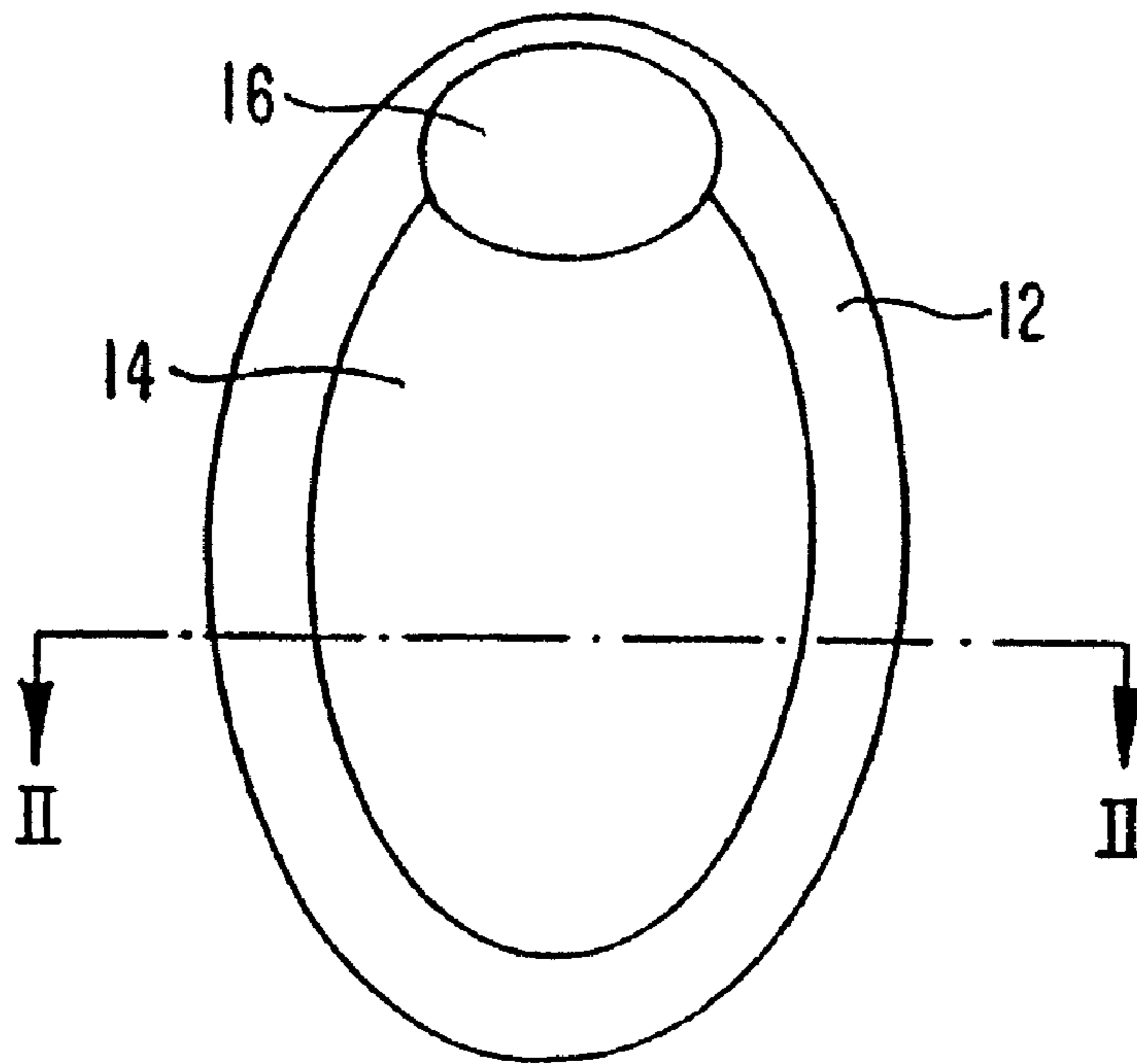

FIG. 2

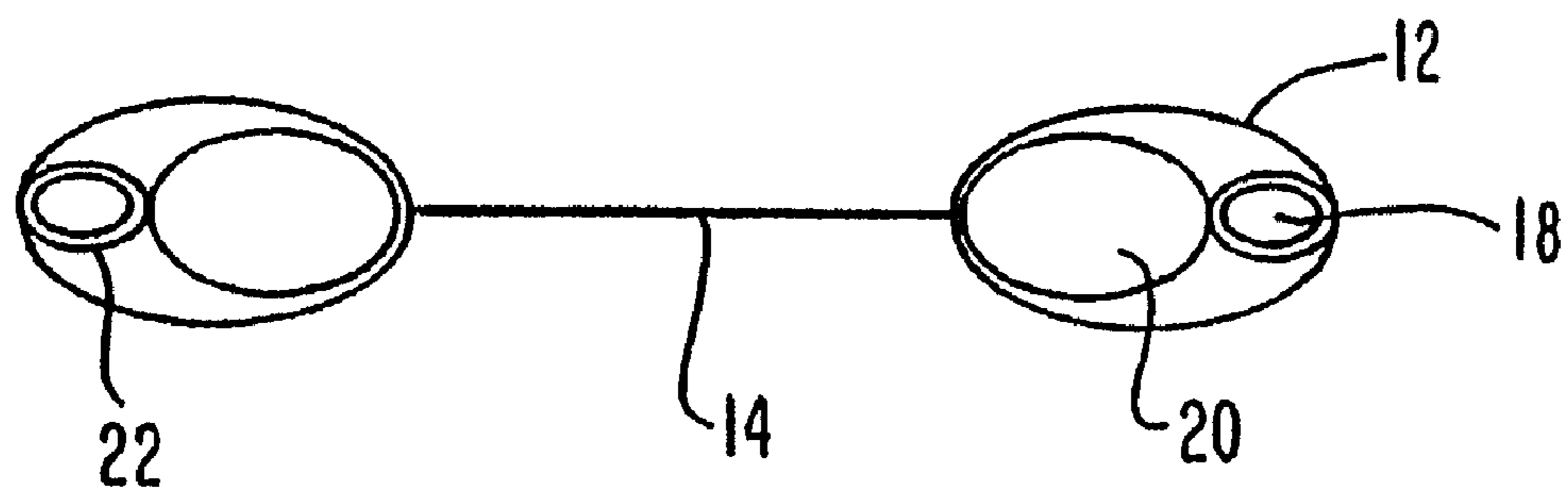

FIG. 3

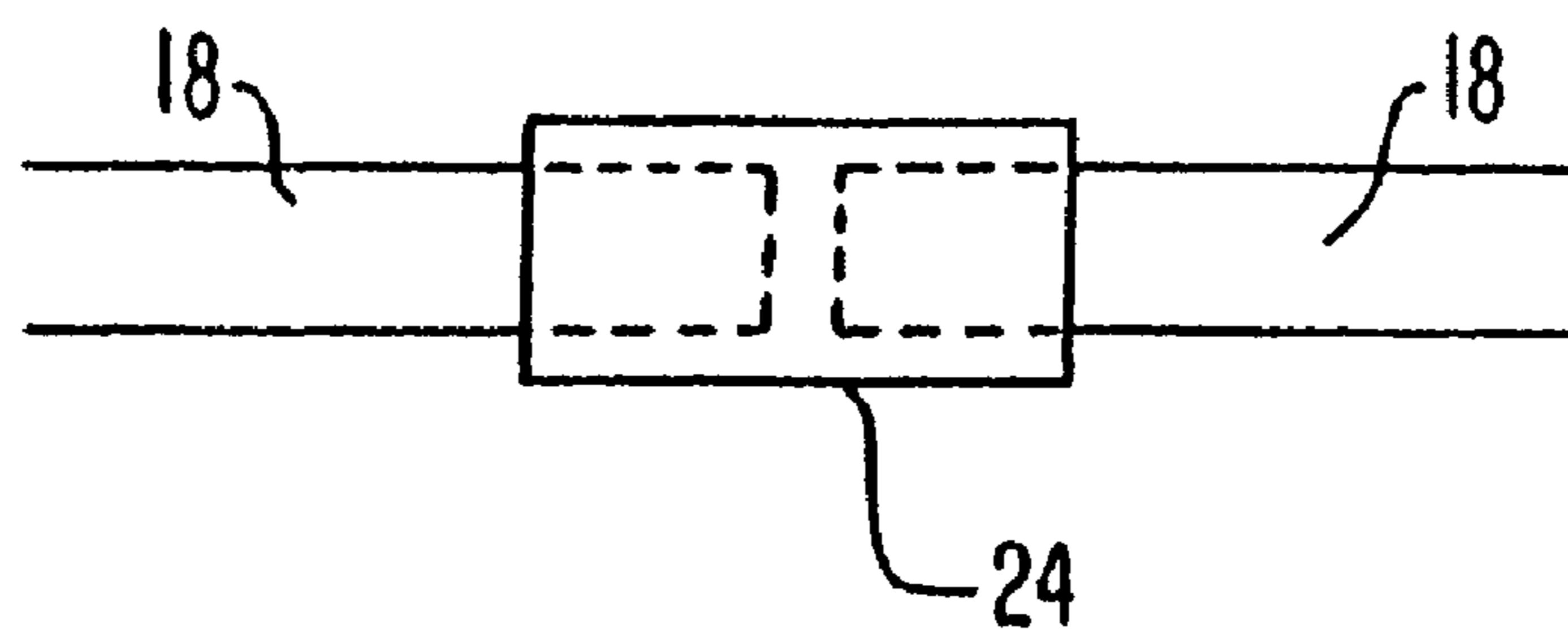

FIG. 4

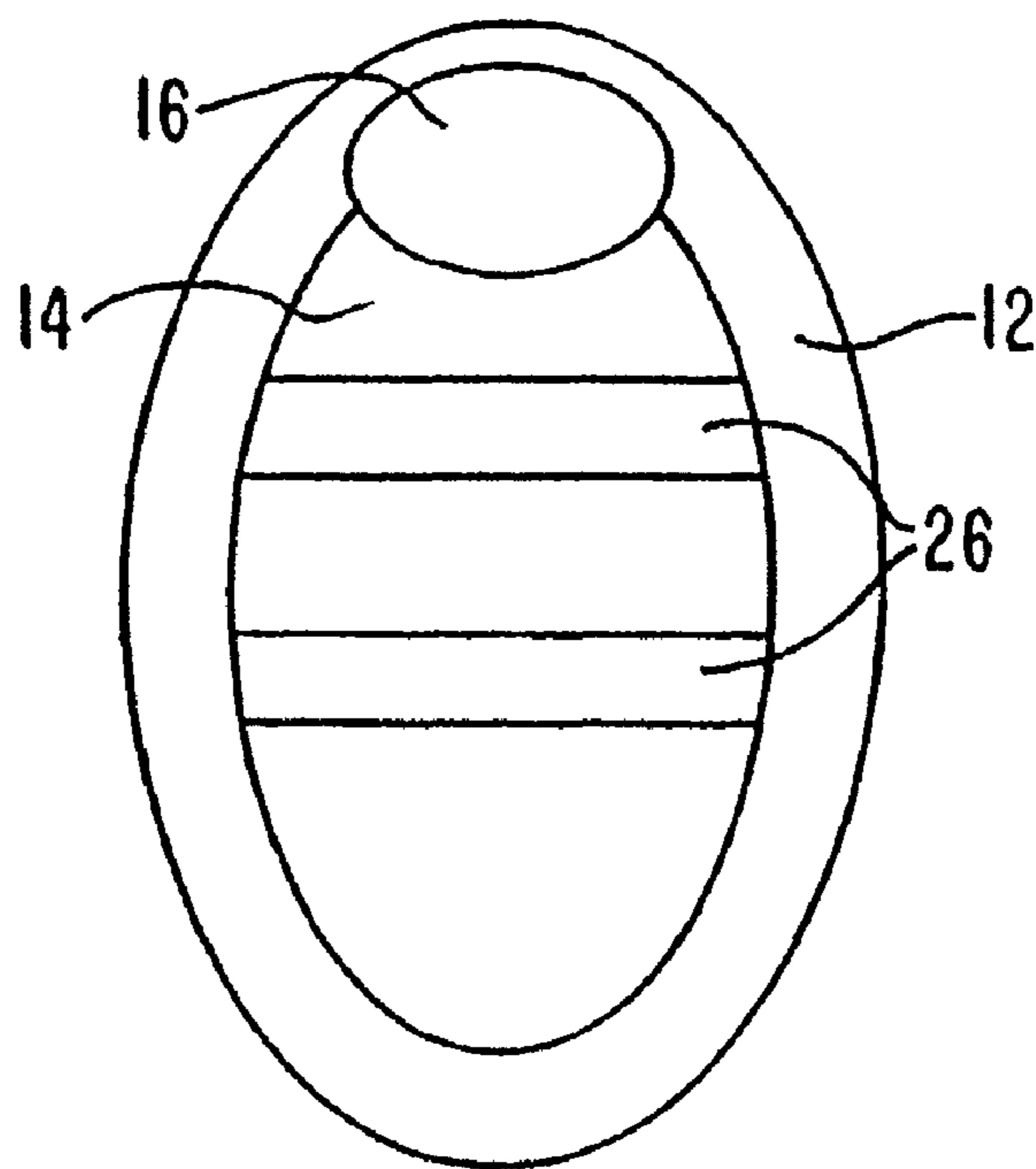

FIG. 5

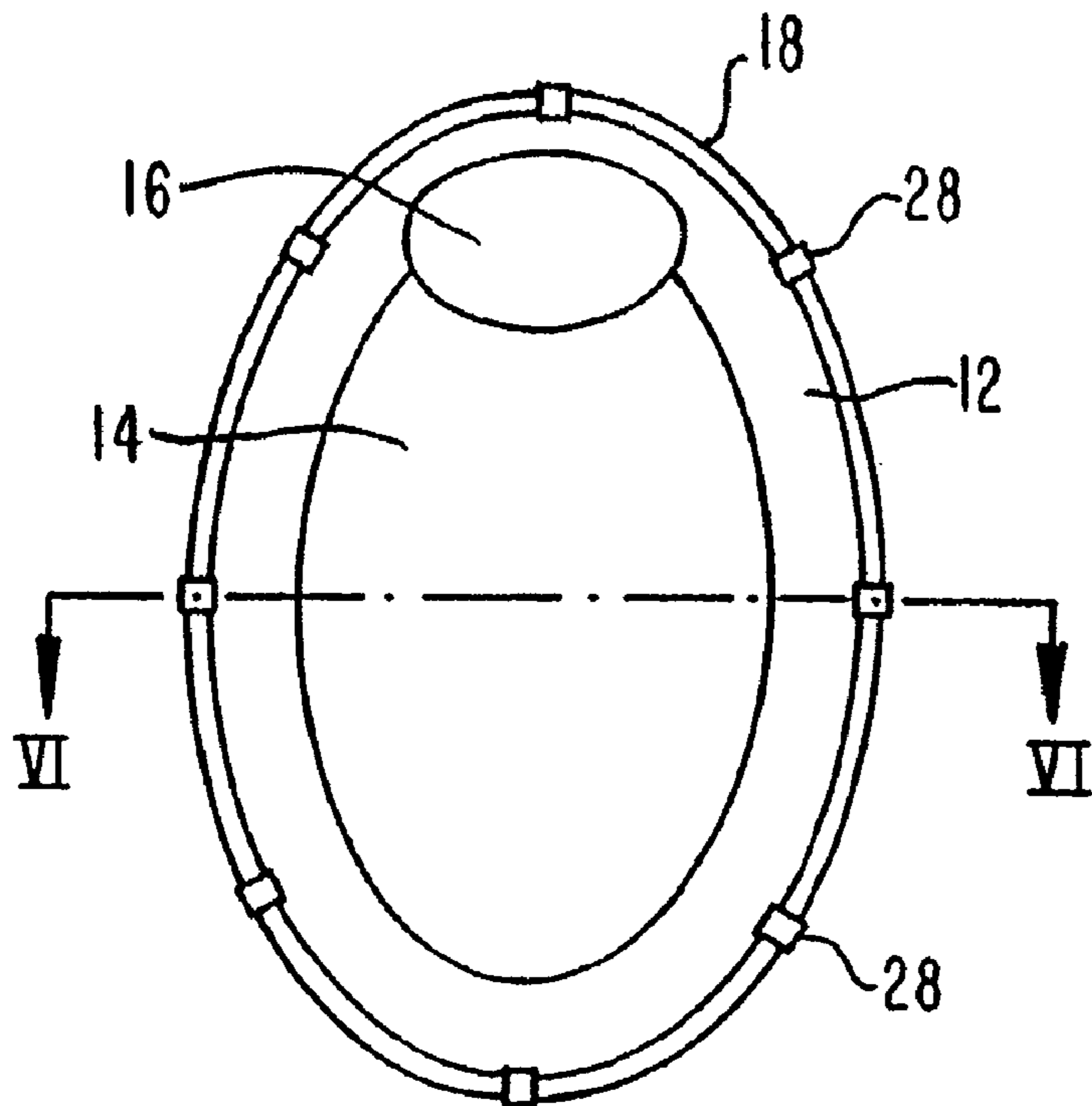

FIG. 6

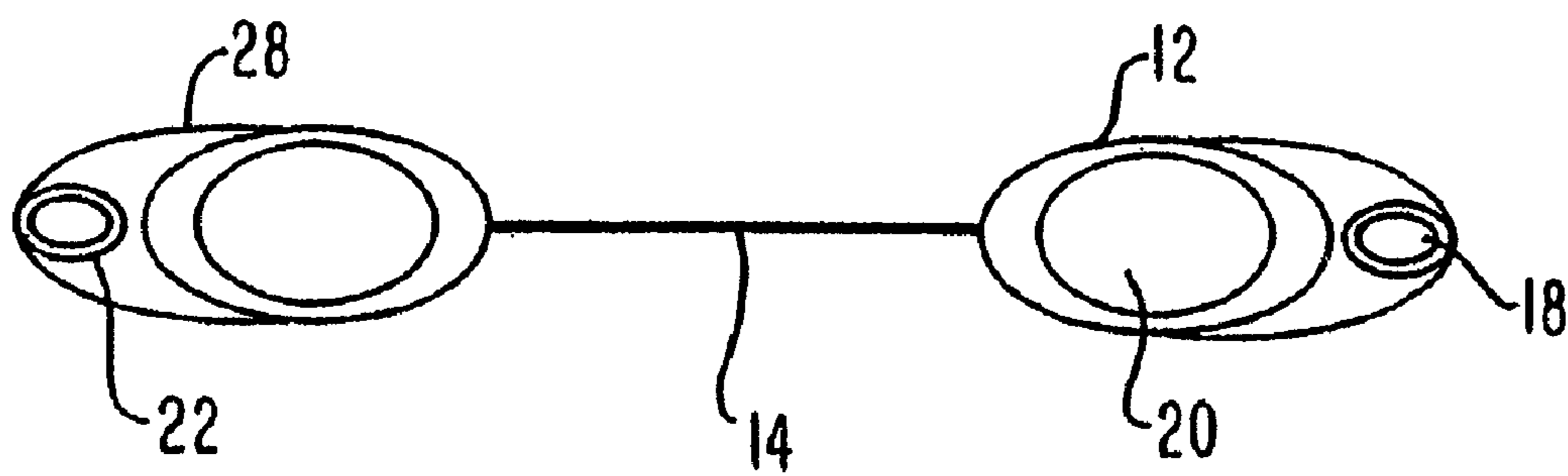

FIG. 7

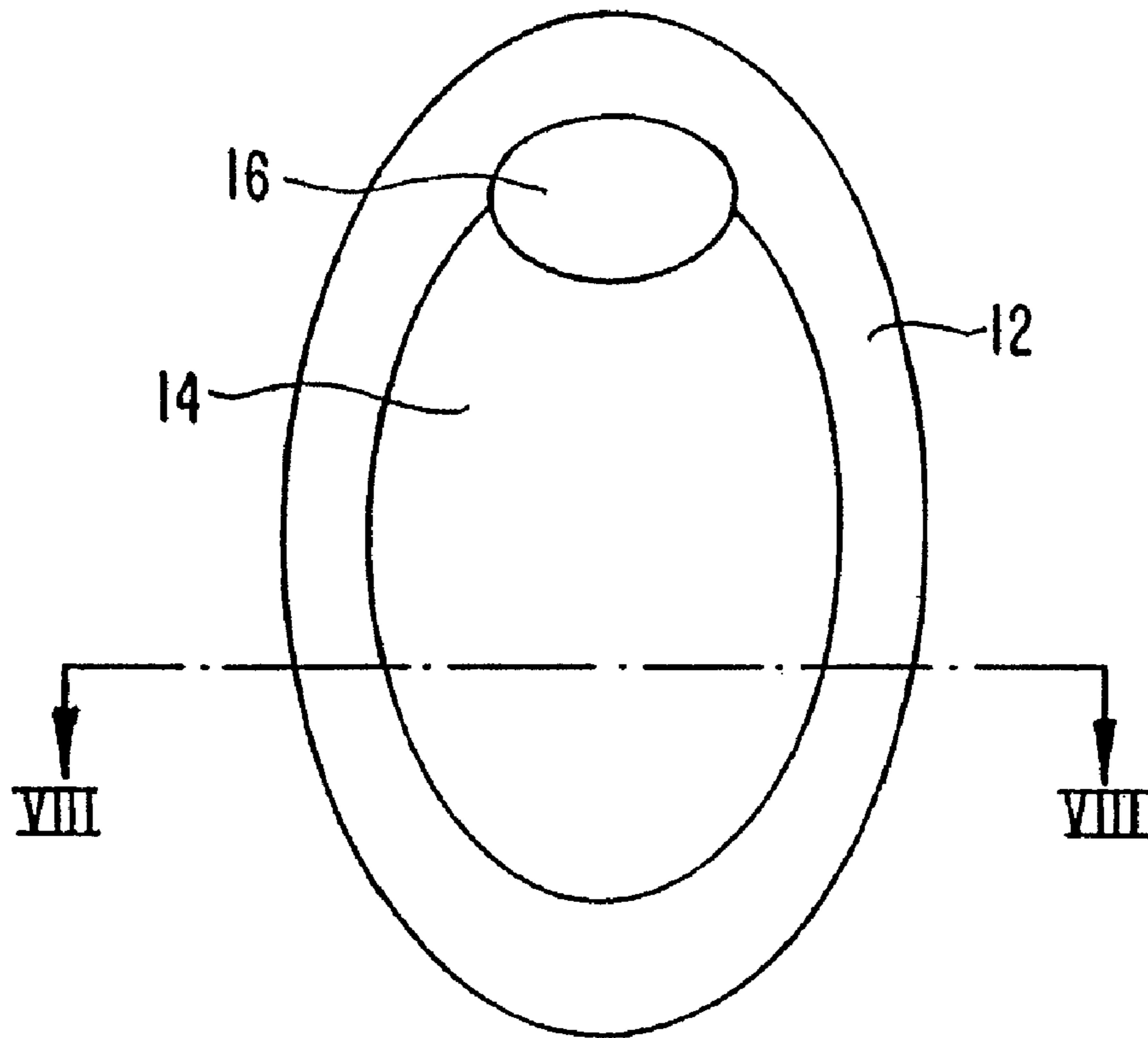

FIG. 8

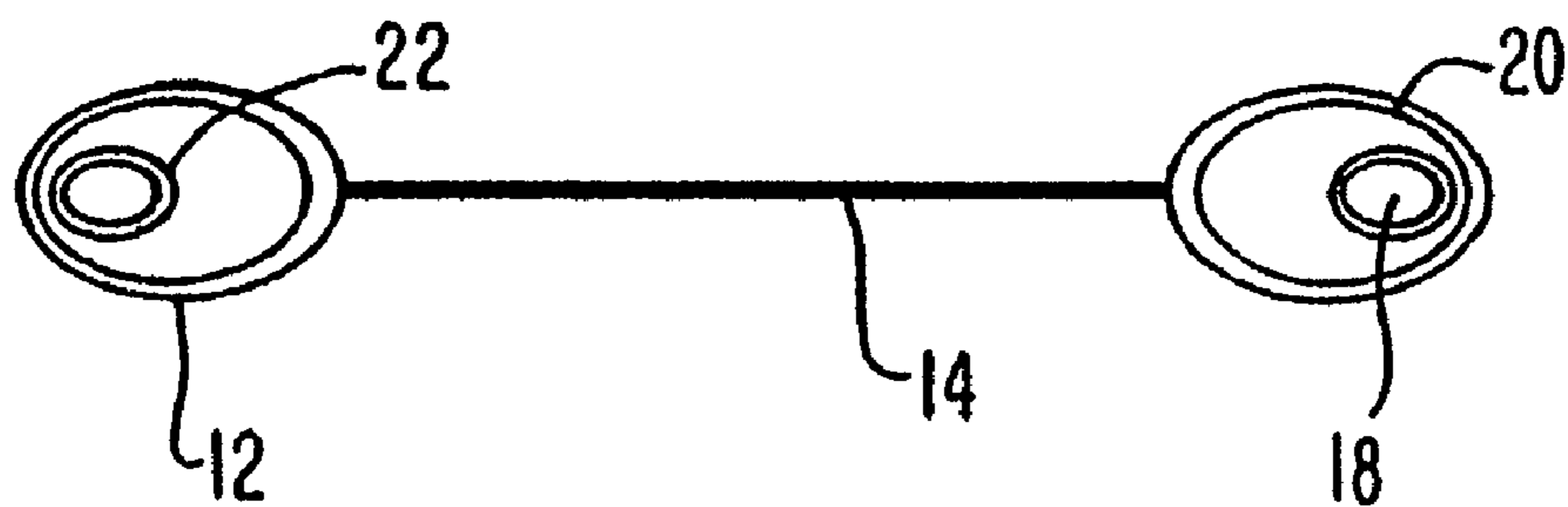
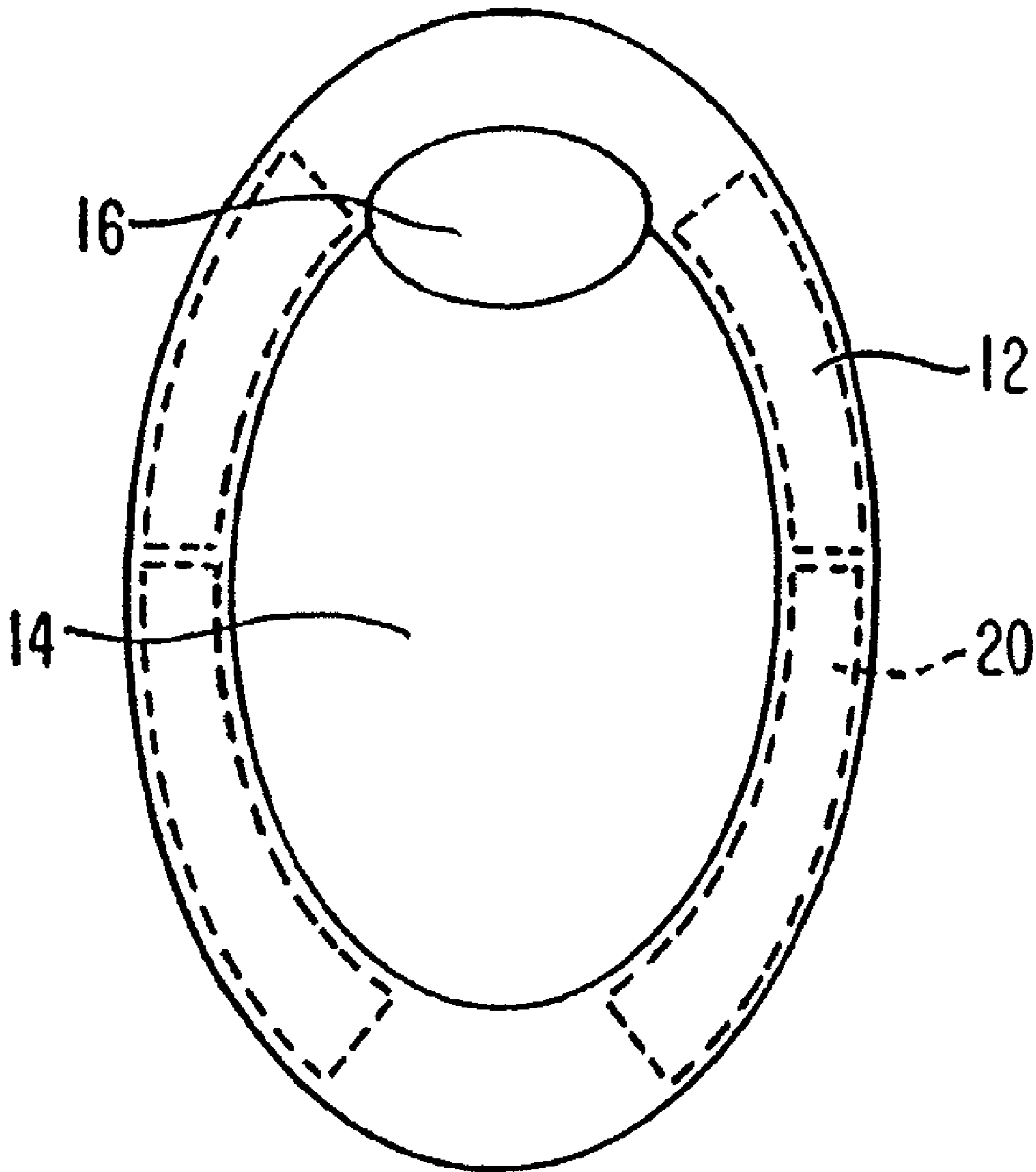

FIG. 9



COLLAPSIBLE FLOTATION DEVICE**CROSS REFERENCE TO RELATED APPLICATION**

This application is a continuation of U.S. application Ser. No. 12/400,214, filed Mar. 9, 2009 (now U.S. Pat. No. 7,811,145), which is a continuation of U.S. application Ser. No. 12/028,227, filed Feb. 8, 2008 (now U.S. Pat. No. 7,500,893), which is a continuation of U.S. application Ser. No. 11/554,197, filed Oct. 30, 2006 (now U.S. Pat. No. 7,335,080), which is a continuation of Ser. No. 11/143,703, filed Jun. 3, 2005 (now U.S. Pat. No. 7,134,930), which is a continuation of U.S. application Ser. No. 10/847,339, filed May 18, 2004 (now U.S. Pat. No. 7,147,528), which is a continuation of U.S. application Ser. No. 10/295,906, filed Nov. 18, 2002, (now U.S. Pat. No. 7,097,524), which is also a continuation of U.S. application Ser. No. 09/772,739, filed Jan. 30, 2001, (now U.S. Pat. No. 6,485,344), which claims priority from U.S. Provisional Application Ser. No. 60/238,988, filed Oct. 10, 2000; the entire disclosures of which are incorporated herein by reference.

BACKGROUND OF THE INVENTION**1. Field of the Invention**

The present invention relates to inflatable flotation devices. In particular, the present invention relates to inflatable flotation devices which are collapsible through use of a spring mechanism.

2. Description of the Related Art

Inflatable flotation devices are well known in the form of floats, rafts, lifeboats, life preservers and other like devices. Previously known devices generally maintain their shape through air pressure alone and generally collapse when deflated.

In one of many examples, U.S. Pat. No. 3,775,782 issued to Rice et al. describes an inflatable rescue raft. When deflated, the raft can be rolled into a compact size.

Also well known in the art are collapsible items which are collapsible through the use of a collapsible metal or plastic spring. U.S. Pat. No. 4,815,784 shows an automobile sun shade which uses these collapsible springs. The springs are also used in children's play structures (U.S. Pat. Nos. 5,618,246 and 5,560,385) and tent-like shade structures (U.S. Pat. Nos. 5,579,799 and 5,467,794).

The collapsible springs are typically retained or held within fabric sleeves provided along the edges of a piece of fabric or other panel. The collapsible springs may be provided as one continuous loop, or may be a strip or strips of material connected at the ends to form a continuous loop. These collapsible springs are usually formed of flexible coilable steel, although other materials such as plastics are also used. The collapsible springs are usually made of a material which is relatively strong and yet is flexible to a sufficient degree to allow it to be coiled. Thus, each collapsible spring is capable of assuming two configurations, a normal uncoiled or expanded configuration, and a coiled or collapsed configuration in which the spring is collapsed into a size which is much smaller than its open configuration. The springs may be retained within the respective fabric sleeves without being connected thereto. Alternatively, the sleeves may be mechanically fastened, stitched, fused, or glued to the springs to retain them in position.

SUMMARY OF THE DISCLOSURE

A device comprises a spring and a sleeve. The spring is configured to form a closed loop. The spring is moveable

between a coiled configuration when the spring is collapsed and an uncoiled configuration when the spring is expanded. The spring defines a circumference while in the uncoiled configuration. The spring is disposed within the sleeve. The sleeve includes an inflatable portion disposed about at least a portion of the circumference.

It is therefore an object of the present invention to provide a collapsible flotation device.

It is another object of the present invention to provide a collapsible flotation device which is easily collapsed and extended to full size through a mechanical means.

It is yet another object of the present invention to provide a collapsible flotation device which is easily collapsed and extended to full size through the use of a spring.

It is yet a further object of the present invention to provide a collapsible flotation device which requires minimal force to twist and fold into the collapsed configuration.

Finally, it is an object of the present invention to accomplish the foregoing objectives in a simple and cost effective manner.

DESCRIPTION OF THE DRAWINGS

FIG. 1 is a top view of the preferred embodiment of the present invention;

FIG. 2 is a cross sectional view of the preferred embodiment of the present invention taken along line II-II of FIG. 1;

FIG. 3 is a view of a joining method as used in one embodiment of the present invention;

FIG. 4 is a top view of an alternate embodiment of the present invention;

FIG. 5 is a top view of another alternate embodiment of the present invention;

FIG. 6 is a cross section view of the alternate embodiment of the present invention across line VI-VI of FIG. 5;

FIG. 7 is a top view of an alternative embodiment of the present invention;

FIG. 8 is a cross sectional view of the embodiment of the present invention, taken along line VIII-VIII of FIG. 7; and

FIG. 9 is a plan view of another embodiment of the present invention.

DETAILED DESCRIPTION OF THE PREFERRED EMBODIMENTS

The following detailed description is of the best presently contemplated modes of carrying out the invention. This description is not to be taken in a limiting sense, but is made merely for the purpose of illustrating general principles of embodiments of the invention.

The present invention provides a collapsible flotation device. The device includes a coilable metal or plastic spring. The coilable spring can be made from other materials, however, it is important that the coilable spring be made from a material that is strong and flexible. The spring must be coilable such that it folds on top of itself to become more compact. In its uncoiled state, the coilable spring can be round or oval or any shape satisfactory for use as a flotation device. Because it is to be used in water, the coilable spring is preferably either manufactured from a waterproof material or coated to protect any material which is not waterproof. The coilable spring can be a single continuous element or can include a joining means, such as a sleeve, for joining the ends of one or more spring elements together. The coilable spring can be of any appropriate shape and dimension. The coilable

3

spring also has memory such that is biased to return to its uncoiled configuration when not held in the coiled configuration.

Stretched across the coilable spring is a flexible panel of material. The flexible panel can be one continuous piece or can be made up of several different types of material. In a preferred embodiment, the center portion of the flexible panel is mesh to allow water to flow through while the perimeter edges are nylon or polyester. At the edges of the flotation device, the material is a double thickness, forming a pocket around the perimeter of the flotation device. In this pocket are one or more inflatable chambers. One inflatable chamber may surround the entire perimeter of the flotation device or it may be divided into two or more inflatable chambers with each inflatable chamber having a means for inflating and deflating the inflatable chamber. In a preferred embodiment, one inflatable chamber is specifically designed to accommodate the user's head. In this embodiment, the pocket formed by the material is wider along a small portion of the perimeter of the flotation device to allow for a wider inflatable chamber. This will prevent the user's head from sinking below the rest of the user's body. The size of the inflatable chamber can vary significantly and need only be as wide as necessary to support the user's body weight. A preferred embodiment includes an inflatable chamber which is 3 inches in diameter when inflated. The inflatable chamber can be made from any appropriate float material but is preferably resistant to punctures. The coilable spring may also be located within the perimeter pocket. If one inflatable chamber is selected, the coilable spring can be placed inside or outside the inflatable chamber. If multiple inflatable chambers are used, the coilable spring will be outside the inflatable chambers. Alternatively, the coilable spring may be located outside the perimeter pocket along the outer edge of the flotation device. The coilable spring may be attached to the flexible panel through mechanical means such as fastening, stitching, fusing, or gluing.

A preferred embodiment of the flotation device is shown in FIGS. 1 and 2 in its expanded configuration. The perimeter pocket 12 portion of the flexible panel is nylon while the central portion 14 of the flexible panel is made from a mesh material. The pillow 16 is part of the perimeter pocket 12 as it includes a double layer of fabric to accept an inflatable chamber 20 between the layers of fabric. In this particular embodiment, there are two inflatable chambers 20 in the perimeter pocket of the flotation device and one in the pillow 16, each of which includes a means for inflating the inflatable chamber 20. The inflation means is a valve on the underside of the flotation device. The inflatable chambers 20 in the perimeter pocket of the flotation device expand to approximately a 3-inch diameter when inflated. The coilable spring 18 is made from flexible, collapsible steel and is coated with a layer of PVC 22 to protect the coilable spring 18 from corroding and rusting due to contact with water during normal use of the flotation device. The coilable spring 18 also has memory such that will open to its uncoiled configuration when not held in the coiled configuration. The coilable spring 18 can be a single unitary element or can include sleeves 24 for joining the ends of one or more strips as shown in FIG. 3 in which the ends of the coilable spring 18 within the sleeve 24 are shown in dashed lines for clarification.

Alternatively or in addition to the perimeter inflatable chambers, the device can include inflatable chambers 26 which cross the panel as shown in FIG. 4. FIGS. 5 and 6 show a further alternate embodiment of the present invention in which the coilable spring 18 is attached to the external perimeter of the pocket portion 12 of the flexible panel through the use of a mechanical means. In this particular embodiment,

4

several loops 28 are used to attach the coilable spring 18 to the pocket portion 12 of the flexible panel.

While the description above refers to particular embodiments of the present invention, it will be understood that many modifications may be made without departing from the spirit thereof. The accompanying claims are intended to cover such modifications as would fall within the true scope and spirit of the present invention.

What is claimed is:

1. An apparatus, comprising:
 - a first flexible material having an outer perimeter portion;
 - a second flexible material having an inner perimeter portion and an outer perimeter portion, the inner perimeter portion and the outer perimeter portion collectively defining a sleeve, the second flexible material being different than the first flexible material, the inner perimeter portion of the second flexible material being fixedly coupled, at least in part, to the outer perimeter portion of the first flexible material;
 - an inflatable bladder disposed within the sleeve, the apparatus having an extended configuration when inflated for use in water and a collapsed configuration when not inflated, the inflatable bladder being a sufficient size when inflated to maintain the apparatus in the extended configuration and support the weight of a user of the apparatus when the apparatus is disposed in water and the user is disposed in a supine position on the apparatus; and
 - an inflatable pillow fixedly coupled to at least one of the first flexible material or the second flexible material, the second flexible material and the inflatable pillow collectively defining an interior region, the first flexible material being disposed within the interior region.
2. The apparatus of claim 1, further comprising:
 - a spring coupled to the second flexible material and configured to form a closed loop, the spring being moveable between a coiled configuration when the spring is collapsed and an uncoiled configuration when the spring is expanded.
3. The apparatus of claim 1, wherein the inflatable pillow is disposed offset from the outer perimeter portion of the first flexible material.
4. The apparatus of claim 1, further comprising:
 - a membrane coupled to the inflatable pillow, the inflatable pillow is disposed between the membrane and at least one of the first flexible material or the second flexible material.
5. The apparatus of claim 1, further comprising:
 - a valve coupled to the inflatable bladder and accessible from outside of the second flexible material, the valve configured to communicate air to at least a portion of the inflatable bladder.
6. The apparatus of claim 1, wherein at least a portion of the inflatable bladder has a diameter when inflated of approximately 3 inches.
7. The apparatus of claim 1, wherein the inflatable pillow having a length and a width when inflated, the width being greater than the length to support a user's head above a remaining portion of the user's body when the inflatable pillow is inflated.
8. The apparatus of claim 1, wherein the first flexible material is substantially planar when the inflatable bladder is inflated and the apparatus is in the extended configuration.
9. An apparatus, comprising:
 - a first flexible material having an outer perimeter portion;
 - a second flexible material having an inner perimeter portion and defining a first inflatable bladder, the inner

5

perimeter portion of the second flexible material being coupled to the outer perimeter portion of the first flexible material;

the first inflatable bladder being a sufficient size when inflated to support a user on the apparatus when the apparatus is disposed in water and the user is disposed in a supine position on the apparatus;

a second inflatable bladder coupled to at least one of the first flexible material or the second flexible material, the first inflatable bladder and the second inflatable bladder collectively defining an interior region, the first flexible material being disposed within the interior region; and

a third flexible material coupled to at least one of the first flexible material or the second flexible material, the third flexible material forming a pocket, the second inflatable bladder being disposed within the pocket of the third flexible material.

10. The apparatus of claim **9**, further comprising:
a sleeve having an inner perimeter portion coupled to the outer perimeter portion of the first flexible material, the second flexible material disposed at least partially within the sleeve.

11. The apparatus of claim **9**, further comprising:
a spring coupled to an outer perimeter portion of the second flexible material, the spring configured to form a closed loop, the spring being moveable between a coiled configuration when the spring is collapsed and an uncoiled configuration when the spring is expanded.

12. The apparatus of claim **9**, wherein the first flexible material is formed with a mesh material such that at least a portion of the user's body is exposed to water when the user is disposed on the apparatus, and the second flexible material is one of a nylon material or a polyester material.

13. The apparatus of claim **9**, further comprising:
a valve coupled to the first inflatable bladder, the valve configured to communicate air to the first inflatable bladder.

14. The apparatus of claim **9**, further comprising:
a first valve coupled to the first inflatable bladder, the first valve configured to communicate air to the first inflatable bladder; and
a second valve coupled to the second inflatable bladder, the second valve configured to communicate air to the second inflatable bladder.

15. An apparatus, comprising:
a first flexible material having an outer perimeter portion;
a second flexible material defining an inflatable chamber and an inner perimeter portion, the inner perimeter portion of the second flexible material being fixedly coupled to the outer perimeter portion of the first flexible material;
an inflatable pillow coupled to at least one of the first flexible material or the second flexible material, at least a portion of a perimeter portion of the inflatable pillow and the second flexible material collectively defining an interior region, the first flexible material being disposed within the interior region, the inflatable pillow having a

6

size when inflated sufficient to support a head of a user of the apparatus above a remaining portion of the user's body when the apparatus is disposed in water and the user is disposed in a supine position on the apparatus; and

a valve coupled to the second flexible material, the valve configured to communicate air to the inflatable chamber of the second flexible material.

16. The apparatus of claim **15**, further comprising:
a spring coupled to the second flexible material, the spring forming a closed loop and being moveable between a coiled configuration when the spring is collapsed and an uncoiled configuration when the spring is expanded.

17. The apparatus of claim **15**, wherein the valve is a first valve, the apparatus further comprising:
a second valve coupled to the inflatable pillow and configured to communicate air to the inflatable pillow.

18. The apparatus of claim **15**, wherein the first flexible material is formed with a mesh material such that at least a portion of the user's body is exposed to water when the user is disposed on the apparatus, and the second flexible material is at least one of a nylon material or a polyester material.

19. The apparatus of claim **15**, wherein the first flexible material has an outer most perimeter defining a shape of the first flexible material in a top view when the inflatable chamber of the second flexible material is inflated,
the second flexible material has an outer most perimeter defining a shape of the second flexible material in a top view when the inflatable chamber of the second flexible material is inflated, the shape of the first flexible material in the top view being different than the shape of the second flexible material in the top view when the inflatable chamber of the second flexible material is inflated.

20. The apparatus of claim **15**, wherein the first flexible material has a maximum length greater than a maximum width of the first flexible material, the first flexible material has a centerline defined along the maximum length of the first flexible material,
the inflatable pillow has a maximum width greater than a maximum length of the inflatable pillow, the inflatable pillow has a centerline defined along the maximum length of the inflatable pillow, the centerline of the inflatable pillow is substantially aligned with the centerline of the first flexible material.

21. The apparatus of claim **15**, wherein at least a portion of the inflatable chamber has a diameter when inflated of approximately 3 inches.

22. The apparatus of claim **15**, wherein the first flexible material is substantially planar when the inflatable chamber of the second flexible material is inflated.

23. The apparatus of claim **1**, wherein the first flexible material is formed with a mesh material such that at least a portion of the user's body is exposed to water when the user is disposed on the apparatus, and the second flexible material is formed with at least one of a nylon material or a polyester material.

* * * * *