

US008062212B2

(12) **United States Patent**
Belson

(10) **Patent No.:** **US 8,062,212 B2**
(45) **Date of Patent:** **Nov. 22, 2011**

(54) **STEERABLE ENDOSCOPE AND IMPROVED METHOD OF INSERTION**

(75) Inventor: **Amir Belson**, Cupertino, CA (US)

(73) Assignee: **Intuitive Surgical Operations, Inc.**, Sunnyvale, CA (US)

(*) Notice: Subject to any disclaimer, the term of this patent is extended or adjusted under 35 U.S.C. 154(b) by 0 days.

(21) Appl. No.: **11/129,172**

(22) Filed: **May 13, 2005**

(65) **Prior Publication Data**

US 2005/0222498 A1 Oct. 6, 2005

Related U.S. Application Data

(63) Continuation of application No. 10/229,189, filed on Aug. 26, 2002, which is a continuation of application No. 09/790,204, filed on Feb. 20, 2001, now Pat. No. 6,468,203.

(60) Provisional application No. 60/194,140, filed on Apr. 3, 2000.

(51) **Int. Cl.**
A61B 1/00 (2006.01)

(52) **U.S. Cl.** **600/114; 600/141; 600/146; 600/152**

(58) **Field of Classification Search** **600/114-118, 600/146-152; 348/65-74**

See application file for complete search history.

(56) **References Cited**

U.S. PATENT DOCUMENTS

616,672 A	12/1898	Kelling
2,510,198 A	6/1950	Tesmer
2,533,494 A	12/1950	Mitchell, Jr.
2,767,705 A	10/1956	Moore
3,060,972 A	10/1962	Sheldon

3,071,161 A	1/1963	Ulrich
3,096,962 A	7/1963	Meijs
3,162,214 A	12/1964	Bazinet, Jr.
3,168,274 A	2/1965	Street
3,190,286 A	6/1965	Stokes
3,266,059 A	8/1966	Stelle
3,430,662 A	3/1969	Guarnaschelli
3,497,083 A	2/1970	Anderson

(Continued)

FOREIGN PATENT DOCUMENTS

DE 2823025 12/1979

(Continued)

OTHER PUBLICATIONS

Hasson, H.M., "Technique of Open Laparoscopy", (from step 1 to step 9), May 1979, 2424 North Clark Street, Chicago, Illinois 60614, 3 pages.

(Continued)

Primary Examiner — Matthew J Kasztejna

(57) **ABSTRACT**

A steerable endoscope has an elongated body with a selectively steerable distal portion and an automatically controlled proximal portion. The endoscope body is inserted into a patient and the selectively steerable distal portion is used to select a desired path within the patient's body. When the endoscope body is advanced, an electronic motion controller operates the automatically controlled proximal portion to assume the selected curve of the selectively steerable distal portion. Another desired path is selected with the selectively steerable distal portion and the endoscope body is advanced again. As the endoscope body is further advanced, the selected curves propagate proximally along the endoscope body, and when the endoscope body is withdrawn proximally, the selected curves propagate distally along the endoscope body. This creates a serpentine motion in the endoscope body that allows it to negotiate tortuous curves along a desired path through, around, and between organs within the body.

10 Claims, 6 Drawing Sheets

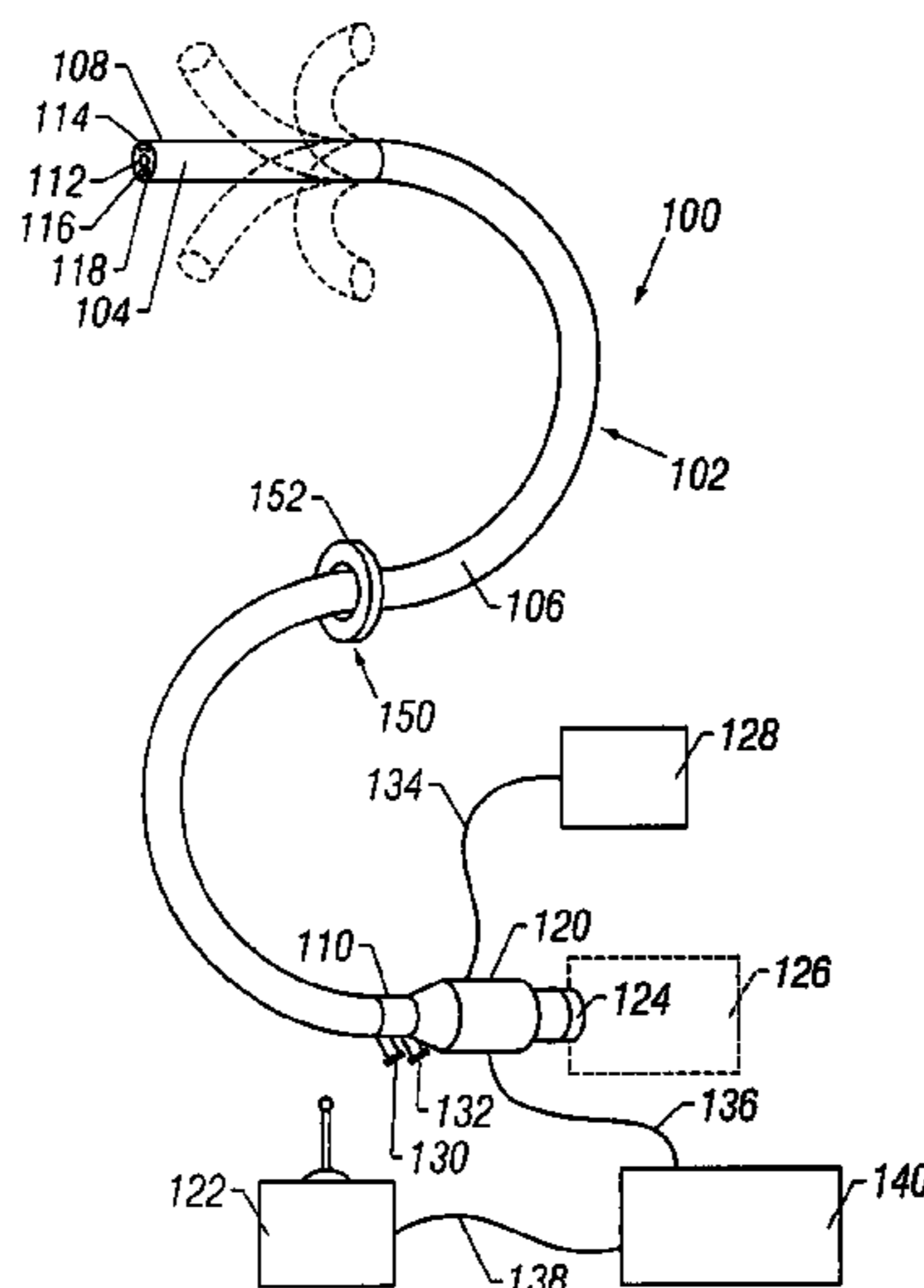

U.S. PATENT DOCUMENTS							
3,546,961	A	12/1970	Marton	4,977,887	A	12/1990	Gouda
3,610,231	A	10/1971	Takahashi	4,987,314	A	1/1991	Gotanda et al.
3,625,084	A	12/1971	Low	5,005,558	A	4/1991	Aomori
3,643,653	A	2/1972	Takahashi et al.	5,005,559	A	4/1991	Blanco et al.
3,739,770	A	6/1973	Mori	5,014,709	A	5/1991	Bjelkhagen et al.
3,773,034	A	11/1973	Burns et al.	5,018,509	A	5/1991	Suzuki et al.
3,780,740	A	12/1973	Rhea	5,025,778	A	6/1991	Silverstein et al.
3,858,578	A	1/1975	Milo	5,060,632	A	10/1991	Hibino et al.
3,871,358	A	3/1975	Fukuda et al.	5,092,901	A	3/1992	Hunter et al.
3,897,775	A	8/1975	Furihata	5,125,395	A	6/1992	Adair
3,913,565	A	10/1975	Kawahara	5,127,393	A	7/1992	McFarlin et al.
3,946,727	A	3/1976	Okada	5,159,446	A	10/1992	Hibino et al.
3,990,434	A	11/1976	Free	5,174,276	A	12/1992	Crockard
4,054,128	A	10/1977	Seufert	5,174,277	A	12/1992	Matsumaru
4,176,662	A	12/1979	Frazer	5,188,111	A	2/1993	Yates et al.
4,233,981	A	11/1980	Schomacher	5,203,319	A	4/1993	Danna et al.
4,236,509	A	12/1980	Takahashi	5,207,695	A	5/1993	Trout, III
4,240,435	A	12/1980	Yazawa et al.	5,217,001	A	6/1993	Nakao et al.
4,273,111	A	6/1981	Tsukaya	5,220,911	A	6/1993	Tamura
4,327,711	A	5/1982	Takagi	5,228,429	A	7/1993	Hatano
4,366,810	A	1/1983	Slanetz, Jr.	5,234,448	A	8/1993	Wholey et al.
4,393,728	A	7/1983	Larson	5,243,967	A	9/1993	Hibino
4,432,349	A	2/1984	Oshiro	5,250,058	A	10/1993	Miller et al.
4,483,326	A	11/1984	Yamaka et al.	5,251,611	A	10/1993	Zehel et al.
4,489,826	A	12/1984	Dubson	5,253,647	A	10/1993	Takahashi
4,494,417	A	1/1985	Larson	5,254,809	A	10/1993	Martin
4,499,895	A	2/1985	Takayama	5,257,617	A	11/1993	Takahashi
4,503,842	A	3/1985	Takayama	5,259,364	A	11/1993	Bob et al.
4,517,652	A	5/1985	Bennett et al.	5,271,381	A	12/1993	Ailinger et al.
4,543,090	A	9/1985	McCoy	5,271,382	A	12/1993	Chikama
4,551,061	A	11/1985	Olenick	5,279,610	A	1/1994	Park et al.
4,559,928	A	12/1985	Takayama	5,297,443	A	3/1994	Wentz
4,566,843	A	1/1986	Iwatsuka	5,325,845	A	7/1994	Adair
4,577,621	A	3/1986	Patel	5,337,732	A	8/1994	Grundfest et al.
4,592,341	A	6/1986	Omagari et al.	5,337,733	A	8/1994	Bauerfeind
4,601,283	A	7/1986	Chikama	5,343,874	A	9/1994	Picha
4,621,618	A	11/1986	Omagari	5,347,987	A	9/1994	Feldstein et al. 600/109
4,624,243	A	11/1986	Lowery et al.	5,348,259	A	9/1994	Blanco et al.
4,630,649	A	12/1986	Oku	5,370,108	A	12/1994	Miura et al.
4,643,184	A	2/1987	Mobin-Uddin	5,383,467	A	1/1995	Auer et al.
4,646,722	A	3/1987	Silverstein et al.	5,383,852	A	1/1995	Stevens-Wright
4,648,733	A	3/1987	Merkt	5,389,222	A	2/1995	Shahinpoor
4,651,718	A	3/1987	Collins et al.	5,394,864	A	3/1995	Kobayashi et al.
4,655,257	A	4/1987	Iwashita	5,400,769	A	3/1995	Tanii et al.
4,683,773	A	8/1987	Diamond	5,402,768	A	4/1995	Adair
4,686,963	A	8/1987	Cohen et al.	5,411,508	A	5/1995	Bessler et al.
4,712,969	A	12/1987	Kimura	5,413,108	A	5/1995	Alfano
4,726,355	A	2/1988	Okada	5,421,337	A	6/1995	Richards-Kortum et al.
4,753,222	A	6/1988	Morishita	5,425,738	A	6/1995	Gustafson et al.
4,753,223	A	6/1988	Bremer	5,429,118	A	7/1995	Cole et al.
4,754,909	A	7/1988	Barker et al.	5,439,000	A	8/1995	Gunderson et al.
4,784,117	A	11/1988	Miyazaki	5,456,714	A	10/1995	Owen
4,787,369	A	11/1988	Allred, III	5,460,166	A	10/1995	Yabe et al.
4,788,967	A	12/1988	Ueda	5,460,168	A	10/1995	Masubuchi et al.
4,793,326	A	12/1988	Shishido	5,469,840	A	11/1995	Tanii et al.
4,796,607	A	1/1989	Allred, III	5,482,029	A	1/1996	Sekiguchi et al.
4,799,474	A	1/1989	Ueda	5,487,757	A	1/1996	Truckai et al.
4,800,890	A	1/1989	Cramer	5,507,287	A	4/1996	Palcic et al.
4,807,593	A	2/1989	Ito	5,507,717	A	4/1996	Kura et al.
4,815,450	A	3/1989	Patel	5,522,788	A	6/1996	Kuzmak
4,832,473	A	5/1989	Ueda	5,531,664	A	7/1996	Adachi et al.
4,834,068	A	5/1989	Gottesman	5,551,945	A	9/1996	Yabe et al.
4,873,965	A	10/1989	Danieli	5,558,619	A	9/1996	Kami et al.
4,873,990	A	10/1989	Holmes et al.	5,558,665	A	9/1996	Kieturakis
4,879,991	A	11/1989	Ogiu	5,577,992	A	11/1996	Chiba et al.
4,884,557	A	12/1989	Takehana et al.	5,586,968	A	12/1996	Grundl et al.
4,890,602	A	1/1990	Hake	5,590,660	A	1/1997	MacAulay et al.
4,895,431	A	1/1990	Tsujiuchi et al.	5,601,087	A	2/1997	Gunderson et al.
4,899,731	A	2/1990	Takayama et al.	5,602,449	A	2/1997	Krause
4,904,048	A	2/1990	Sogawa et al.	5,620,408	A	4/1997	Vennes et al.
4,917,114	A	4/1990	Green et al.	5,624,380	A	4/1997	Takayama et al.
4,919,112	A	4/1990	Siegmund	5,624,381	A	4/1997	Kieturakis
4,930,494	A	6/1990	Takehana et al.	5,626,553	A	5/1997	Frassica et al.
4,949,927	A	8/1990	Madocks et al.	5,645,520	A	7/1997	Nakamura et al.
4,957,486	A	9/1990	Davis	5,647,368	A	7/1997	Zeng et al.
4,969,709	A	11/1990	Sogawa et al.	5,647,840	A	7/1997	D'Amelio et al.
4,971,035	A	11/1990	Ito	5,651,769	A	7/1997	Waxman et al.
4,977,886	A	12/1990	Takehana et al.	5,658,238	A	8/1997	Suzuki et al.
				5,662,587	A	9/1997	Grundfest et al.

US 8,062,212 B2

5,665,050 A	9/1997	Benecke	6,352,503 B1	3/2002	Matsui et al.
5,667,476 A	9/1997	Frassica et al.	6,366,799 B1	4/2002	Acker
5,679,216 A	10/1997	Takayama et al.	6,402,687 B1	6/2002	Ouchi
5,728,044 A	3/1998	Shan	6,408,889 B1	6/2002	Komachi
5,733,245 A	3/1998	Kawano	6,453,190 B1	9/2002	Acker
5,749,828 A	5/1998	Solomon et al.	6,459,481 B1	10/2002	Schaack
5,752,912 A	5/1998	Takahashi et al.	6,468,203 B2	10/2002	Belson
5,759,151 A	6/1998	Sturges	6,482,149 B1	11/2002	Torii
5,762,613 A	6/1998	Sutton et al.	6,485,413 B1	11/2002	Boppart
5,765,561 A *	6/1998	Chen et al. 600/407	6,490,467 B1	12/2002	Bucholz
5,769,792 A	6/1998	Palcic et al.	6,511,417 B1	1/2003	Taniguchi et al.
5,772,597 A	6/1998	Goldberger et al.	6,511,418 B2	1/2003	Shahidi
5,773,835 A	6/1998	Sinofsky	6,517,477 B1	2/2003	Wendlandt
5,779,624 A	7/1998	Chang	6,527,706 B2	3/2003	Ide
5,807,241 A	9/1998	Heimberger	6,537,211 B1	3/2003	Wang et al.
5,810,715 A	9/1998	Moriyama	6,544,215 B1	4/2003	Bencini et al.
5,810,716 A	9/1998	Mukherjee	6,554,793 B1	4/2003	Pauker et al.
5,810,717 A	9/1998	Maeda	6,569,173 B1	5/2003	Blatter et al.
5,813,976 A	9/1998	Filipi et al.	6,610,007 B2	8/2003	Belson et al.
5,827,190 A	10/1998	Palcic et al.	6,616,600 B2	9/2003	Pauker
5,842,973 A	12/1998	Bullard	6,638,213 B2	10/2003	Ogura et al.
5,860,581 A	1/1999	Robertson et al.	6,641,528 B2	11/2003	Torii
5,860,914 A	1/1999	Chiba et al.	6,656,110 B1	12/2003	Irion et al.
5,876,329 A	3/1999	Harhen	6,699,183 B1	3/2004	Wimmer
5,876,373 A	3/1999	Giba et al.	6,761,685 B2	7/2004	Adams et al.
5,885,208 A	3/1999	Moriyama	6,783,491 B2	8/2004	Saadat et al.
5,897,417 A	4/1999	Grey	6,790,173 B2	9/2004	Saadat et al.
5,897,488 A	4/1999	Ueda	6,800,056 B2	10/2004	Tartaglia et al.
5,902,254 A	5/1999	Magram	6,817,973 B2	11/2004	Merril et al.
5,906,591 A	5/1999	Dario et al.	6,843,793 B2	1/2005	Brock et al.
5,908,381 A	6/1999	Aznoian et al.	6,858,005 B2	2/2005	Ohline
5,916,147 A	6/1999	Boury	6,869,396 B2	3/2005	Belson
5,921,915 A	7/1999	Aznoian et al.	6,902,528 B1	6/2005	Garibaldi et al.
5,928,136 A	7/1999	Barry	6,960,161 B2	11/2005	Amiling et al.
5,941,815 A	8/1999	Chang	6,974,411 B2	12/2005	Belson
5,941,908 A	8/1999	Goldsteen et al.	6,984,203 B2	1/2006	Tartaglia et al.
5,957,833 A	9/1999	Shan	7,018,331 B2	3/2006	Chang et al.
5,968,052 A	10/1999	Sullivan et al.	7,087,013 B2	8/2006	Belson et al.
5,971,767 A *	10/1999	Kaufman et al. 434/267	7,167,180 B1 *	1/2007	Shibolet 345/474
5,976,074 A	11/1999	Moriyama	2001/0000040 A1	3/2001	Adams et al.
5,989,182 A	11/1999	Hori et al.	2002/0022765 A1	2/2002	Belson
5,989,230 A	11/1999	Frassica	2002/0062062 A1	5/2002	Belson
5,993,381 A	11/1999	Ito	2002/0120178 A1	8/2002	Targaglia
5,996,346 A	12/1999	Maynard	2002/0120254 A1	8/2002	Julian
6,016,440 A	1/2000	Simon et al.	2002/0147385 A1	10/2002	Butler et al.
6,033,359 A	3/2000	Doi	2002/0161281 A1	10/2002	Jaffe
6,036,636 A	3/2000	Motoki et al.	2002/0193661 A1	12/2002	Belson
6,042,155 A	3/2000	Lockwood	2002/0193662 A1	12/2002	Belson
6,048,307 A	4/2000	Grundl et al.	2003/0045778 A1	3/2003	Ohline
6,066,102 A	5/2000	Townsend et al.	2003/0083550 A1	5/2003	Miyagi
6,066,132 A	5/2000	Chen et al.	2003/0130598 A1	7/2003	Manning et al.
6,096,289 A	8/2000	Goldenberg	2003/0149338 A1	8/2003	Francois et al.
6,099,464 A	8/2000	Shimizu et al.	2003/0167007 A1	9/2003	Belson
6,099,485 A	8/2000	Patterson	2003/0195387 A1	10/2003	Kortenbach et al.
6,106,510 A	8/2000	Lunn et al.	2003/0233027 A1	12/2003	Ewers et al.
6,119,913 A	9/2000	Adams et al.	2003/0233056 A1	12/2003	Saadat et al.
6,129,667 A	10/2000	Dumoulin et al.	2003/0233057 A1	12/2003	Saadat et al.
6,129,683 A	10/2000	Sutton et al.	2003/0233058 A1	12/2003	Ewers et al.
6,141,577 A	10/2000	Roland	2003/0233066 A1	12/2003	Ewers et al.
6,149,581 A	11/2000	Klingenstein	2003/0236505 A1	12/2003	Bonadio et al.
6,162,171 A	12/2000	Ng	2003/0236549 A1	12/2003	Bonadio et al.
6,174,280 B1	1/2001	Oneda et al.	2004/0019254 A1	1/2004	Belson
6,174,291 B1	1/2001	McMahon et al.	2004/0044270 A1	3/2004	Barry
6,179,776 B1	1/2001	Adams	2004/0106852 A1	6/2004	Windheuser et al.
6,201,989 B1	3/2001	Whitehead	2004/0176683 A1	9/2004	Whitin et al.
6,203,493 B1	3/2001	Ben-Haim	2004/0193008 A1	9/2004	Jaffe et al.
6,203,494 B1	3/2001	Moriyama	2004/0193009 A1	9/2004	Jaffe et al.
6,210,337 B1	4/2001	Dunham et al.	2004/0210109 A1	10/2004	Jaffe et al.
6,221,006 B1	4/2001	Dubrul et al.	2004/0220450 A1	11/2004	Jaffe et al.
6,241,657 B1 *	6/2001	Chen et al. 600/117	2005/0020901 A1	1/2005	Belson et al.
6,249,076 B1	6/2001	Madden et al.	2005/0085693 A1	4/2005	Belson et al.
6,270,453 B1	8/2001	Sakai	2005/0124855 A1	6/2005	Jaffe et al.
6,306,081 B1	10/2001	Ishikawa et al.	2005/0154258 A1	7/2005	Tartaglia et al.
6,309,346 B1	10/2001	Farhadi	2005/0154261 A1	7/2005	Ohline et al.
6,315,714 B1	11/2001	Akiba	2005/0165276 A1	7/2005	Belson
6,319,197 B1	11/2001	Tsuji et al.	2005/0209509 A1	9/2005	Belson
6,327,492 B1	12/2001	Lemelson	2005/0222497 A1	10/2005	Belson
6,332,089 B1	12/2001	Acker	2006/0009678 A1	1/2006	Jaffe et al.
6,348,058 B1	2/2002	Melkent	2006/0052664 A1	3/2006	Julian et al.

2006/0235457 A1 10/2006 Belson
 2006/0235458 A1 10/2006 Belson
 2006/0258912 A1 11/2006 Belson et al.
 2007/0043259 A1 2/2007 Jaffe et al.
 2007/0093858 A1 4/2007 Gambale et al.
 2007/0135803 A1 6/2007 Belson
 2007/0161291 A1 7/2007 Swinehart et al.
 2007/0161857 A1 7/2007 Durant et al.
 2007/0249901 A1 10/2007 Ohline et al.
 2007/0270650 A1 11/2007 Eno et al.

WO WO 97/10746 A1 3/1997
 WO WO 98/24017 A2 6/1998
 WO WO 99/33392 A1 7/1999
 WO WO 99/51283 A2 10/1999
 WO WO 99/59664 A1 11/1999
 WO WO 00/27462 5/2000
 WO WO 00/54653 A1 9/2000
 WO WO 00/74565 A1 12/2000
 WO WO 01/49353 A2 7/2001
 WO WO 01/67964 A2 9/2001
 WO WO 01/70096 A1 9/2001
 WO WO 01/70097 A1 9/2001
 WO WO 01/74235 A1 10/2001
 WO WO 01/80935 A1 11/2001
 WO WO 02/24058 A2 3/2002
 WO WO 02/39909 A1 5/2002
 WO WO 02/064028 A1 8/2002
 WO WO 02/068988 A2 9/2002
 WO WO 02/069841 A2 9/2002
 WO WO 02/096276 A1 12/2002
 WO WO 03/028547 A2 4/2003
 WO WO 03/073920 A2 9/2003
 WO WO 03/092476 A2 11/2003
 WO WO 2004/006980 A2 1/2004
 WO WO 2004/049905 A2 6/2004
 WO WO 2004/071284 A1 8/2004
 WO WO 2004/080313 A1 9/2004
 WO WO 2004/084702 A2 10/2004

FOREIGN PATENT DOCUMENTS

DE 2823025 C2 2/1986
 DE 3707787 9/1988
 DE 3707787 A1 9/1988
 DE 4102211 A1 8/1991
 DE 19626433 A1 1/1998
 DE 19729499 A1 1/1999
 EP 0165718 A2 12/1985
 EP 0382974 A1 8/1990
 EP 0497781 B1 1/1994
 EP 1101442 A2 5/2001
 FR 2732225 A1 10/1996
 GB 2347685 A 9/2000
 IE 2000/0225 3/2000
 JP 47-12705 5/1972
 JP 63136014 6/1988
 JP 63-136014 8/1988
 JP 63272322 11/1988
 JP 1152413 6/1989
 JP 1229220 9/1989
 JP 01-262372 10/1989
 JP 2246986 10/1990
 JP 2296209 12/1990
 JP 3136630 6/1991
 JP 4054970 2/1992
 JP 5011196 1/1993
 JP 5111458 5/1993
 JP 5305073 11/1993
 JP 06-007287 1/1994
 JP 07-116104 5/1995
 JP 08-322786 12/1996
 JP 09-028662 2/1997
 JP 10337274 12/1998
 JP 11042258 2/1999
 JP 2001-046318 2/2001
 JP 3322356 9/2002
 SU 871786 10/1981
 SU 1256955 9/1986
 SU 1301701 4/1987
 WO WO 93/17751 A1 3/1993
 WO WO 93/17751 A1 9/1993
 WO WO 94/19051 A1 9/1994
 WO WO 95/04556 A2 2/1995

OTHER PUBLICATIONS

Lee, T.S. et al., "A highly redundant robot system for inspection", Proceedings of Conference on Intelligent Robotics in Field, Factory, Service, and Space (CIRFFSS '94), (Mar. 21-24, 1994), 1:142-148, Houston, Texas.
 McKernan, J.B. et al., "Laparoscopic general surgery", *Journal of the Medical Association of Georgia*, (Mar. 1990), 79(3):157-159.
 Slatkin, A.B. et al., "The development of a robotic endoscope", Proceedings 1995 IEEE/RSJ International Conference on Intelligent Robots and Systems, (Aug. 5-9, 1995), 2:162-171, Pittsburgh, Pennsylvania.
 Science & Technology, *Laptop Magazine*, (Oct. 2002) p. 98.
 Belson et al; U.S. Appl. No. 11/796,220 entitled "Steerable segmented endoscope and method of insertion," filed Apr. 27, 2007.
 Woodley et al; U.S. Appl. No. 11/871,104 entitled "System for managing bowden cables in articulating instruments," filed Oct. 11, 2007.
 Berger, W. L. et al. Sigmoid Stiffener for Decompression Tube Placement in Colonic Pseudo-Obstruction. *Endoscopy*. 2000; 32 (1): 54-57.
 Ohline et al.; U.S. Appl. No. 12/425,272 entitled "Tendon-driven endoscope and methods of use," filed Apr. 16, 2009.

* cited by examiner

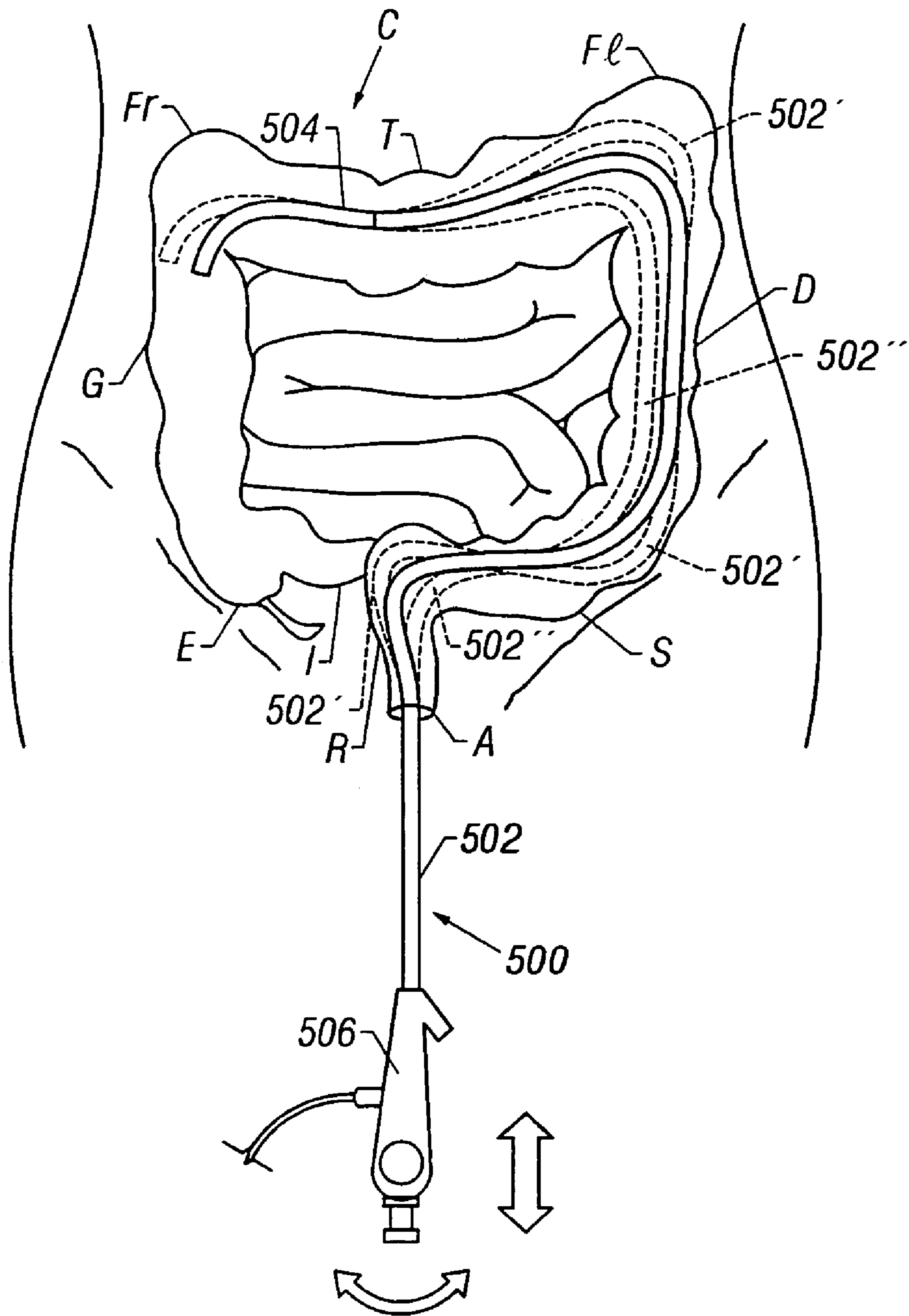

FIG. 1
(Prior Art)

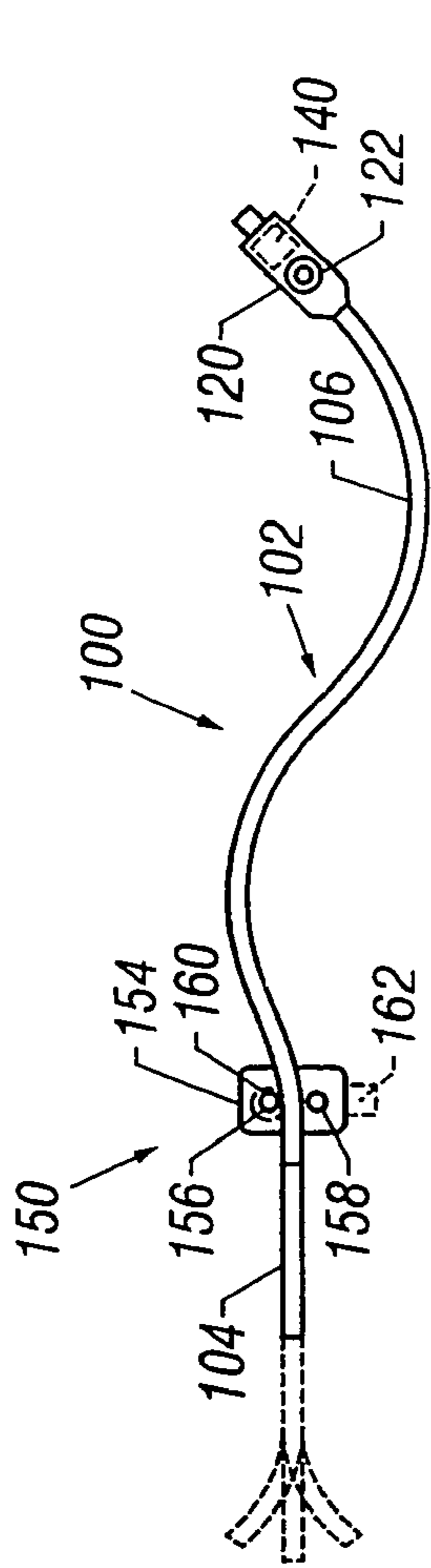

FIG. 3

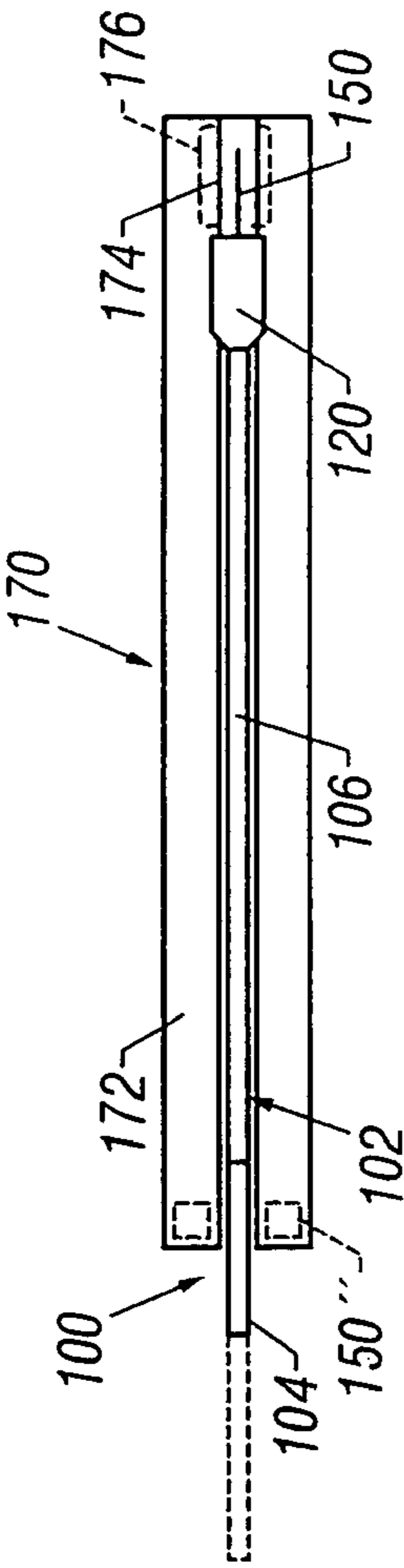
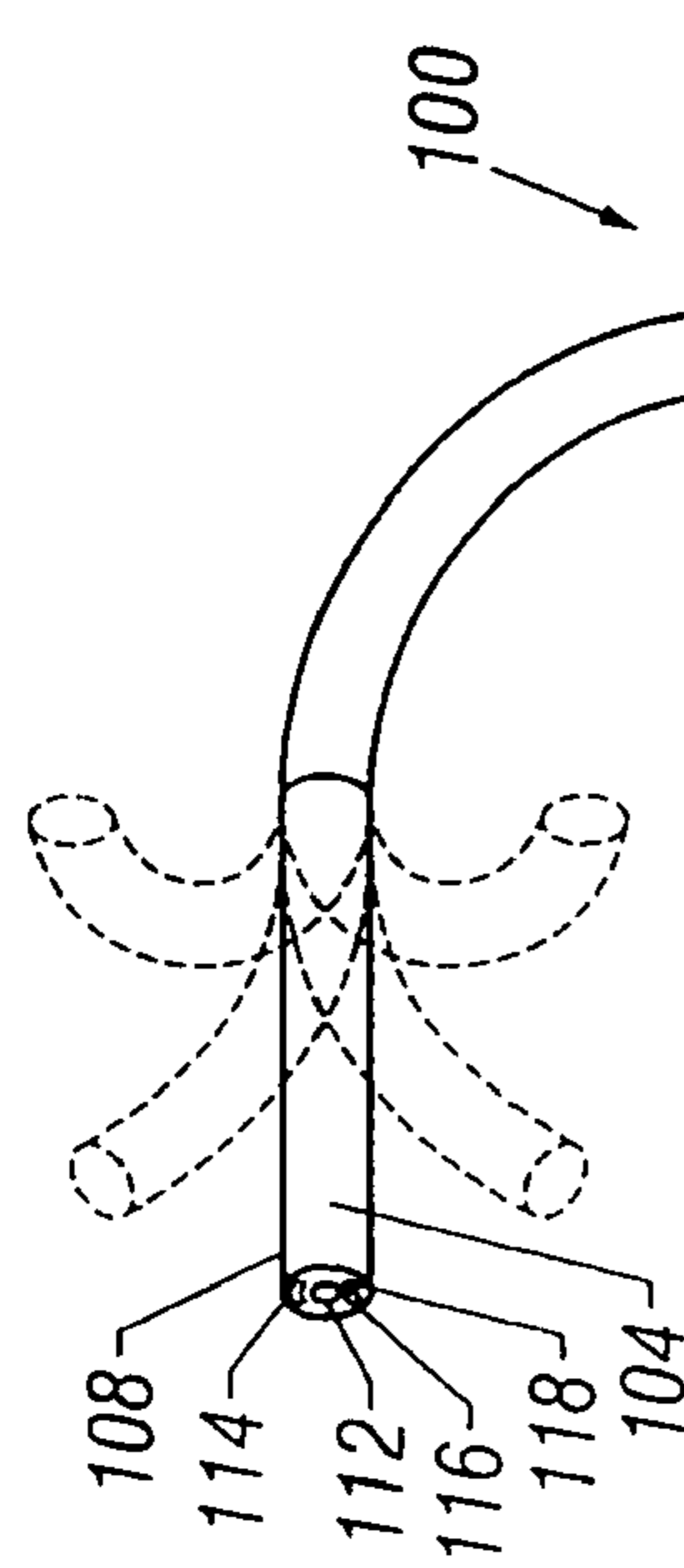

FIG. 4

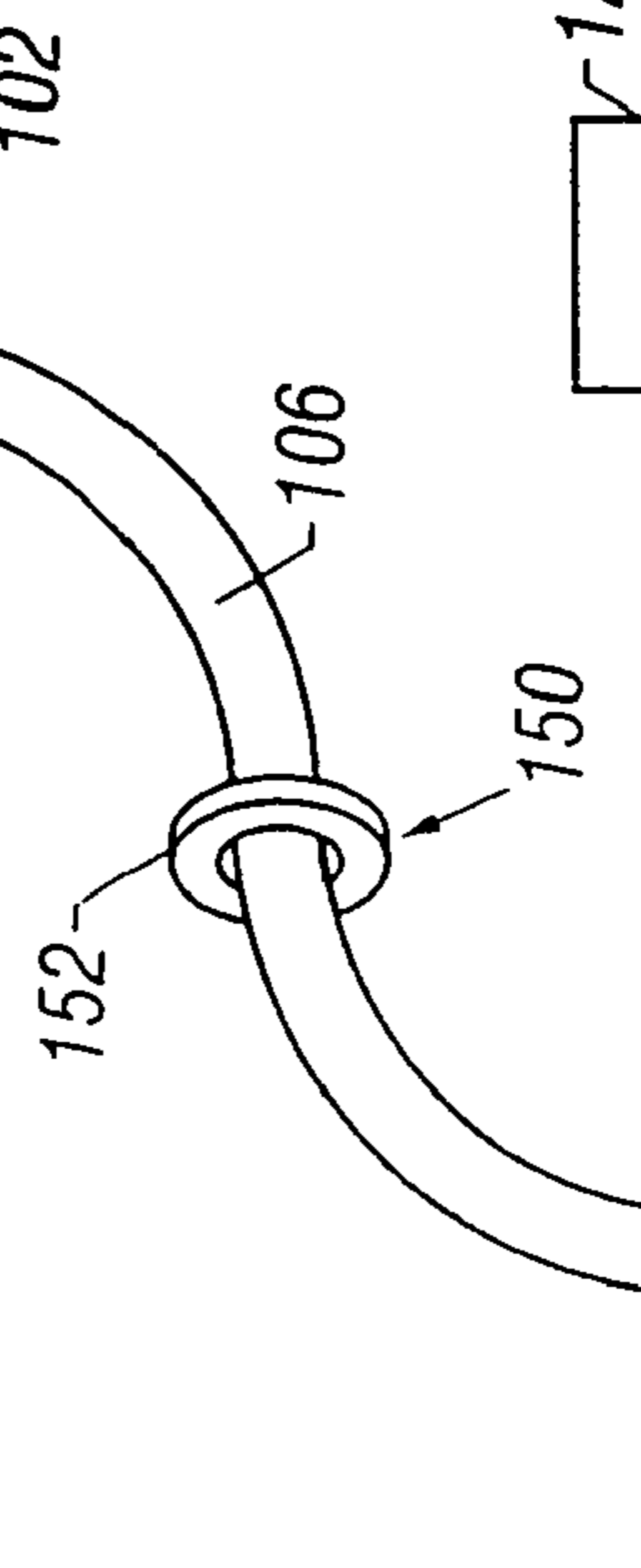

FIG. 5

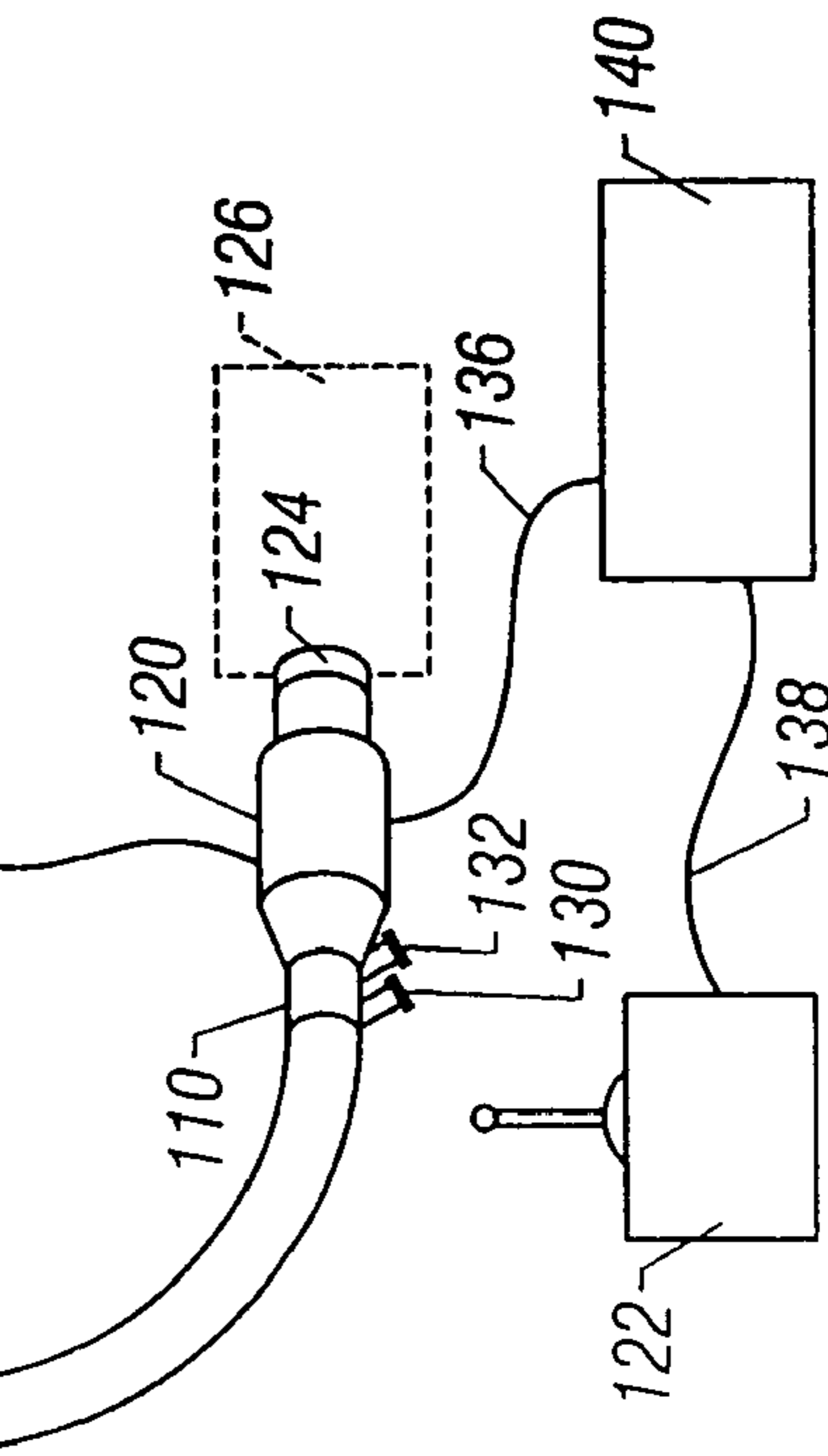

FIG. 2

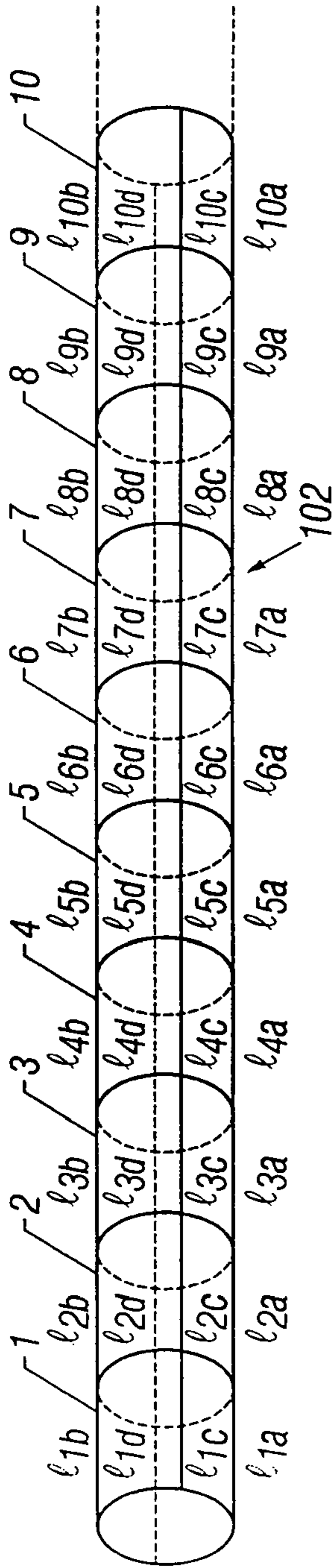

FIG. 6

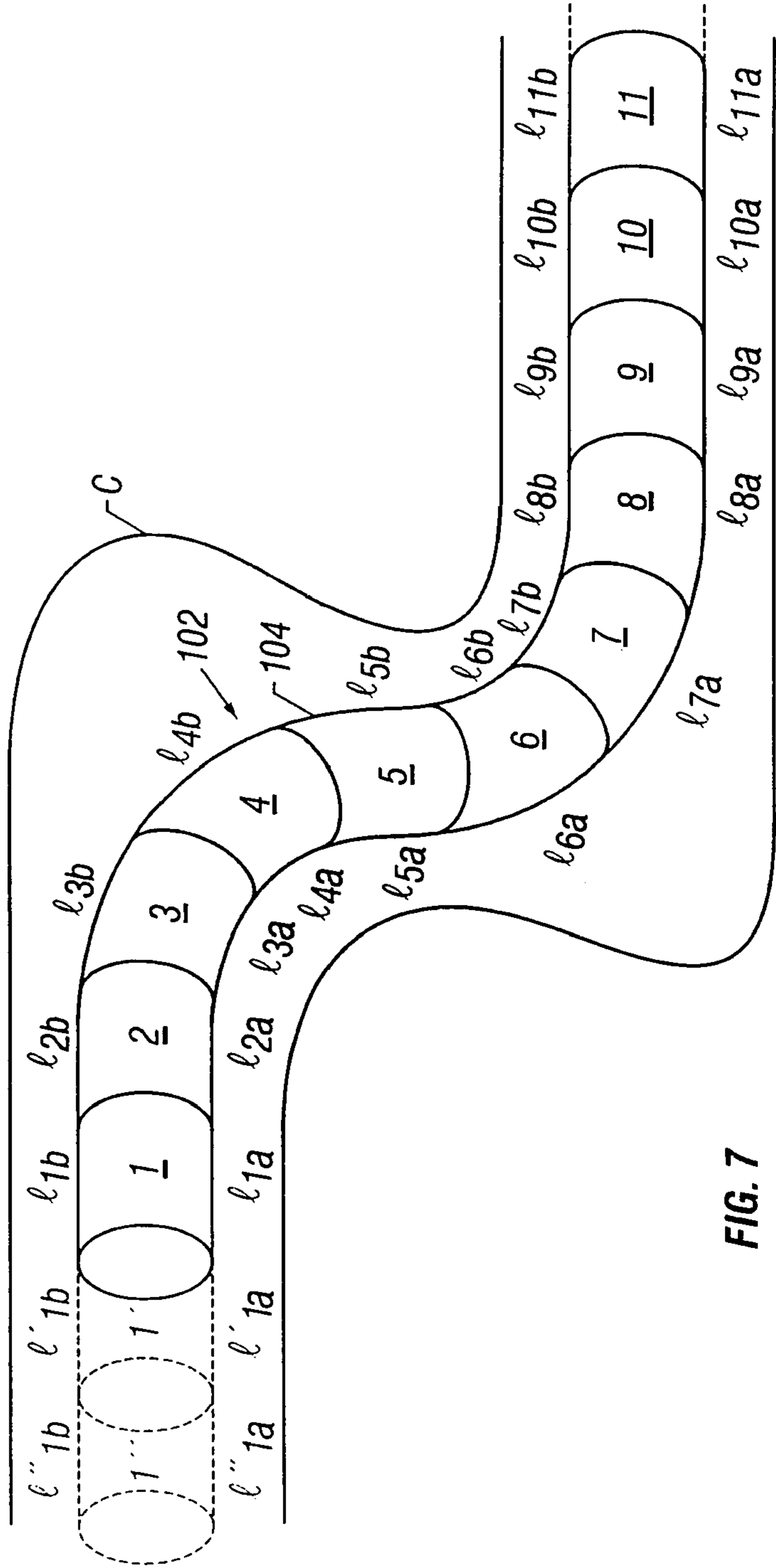

FIG. 7

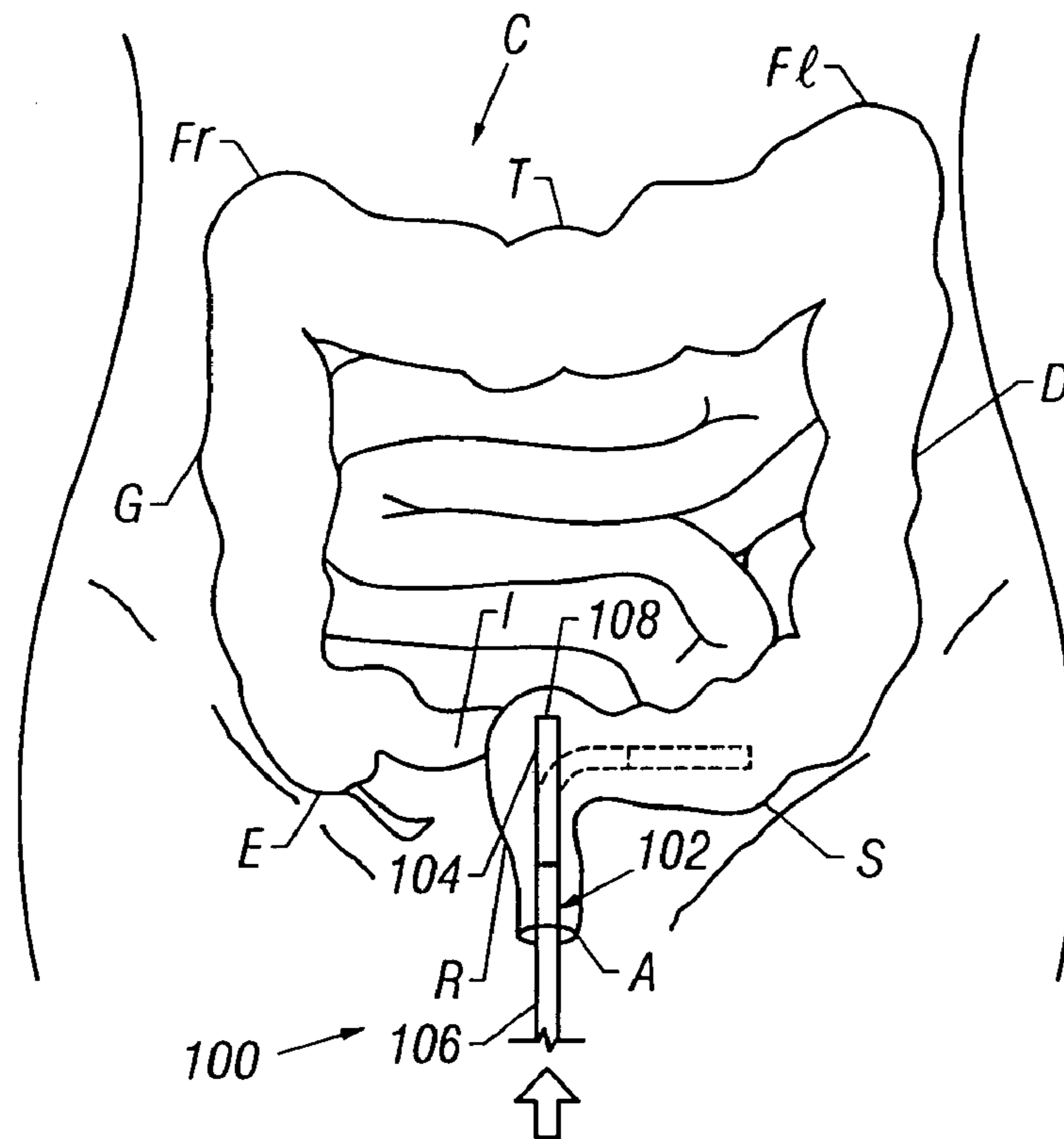

FIG. 8

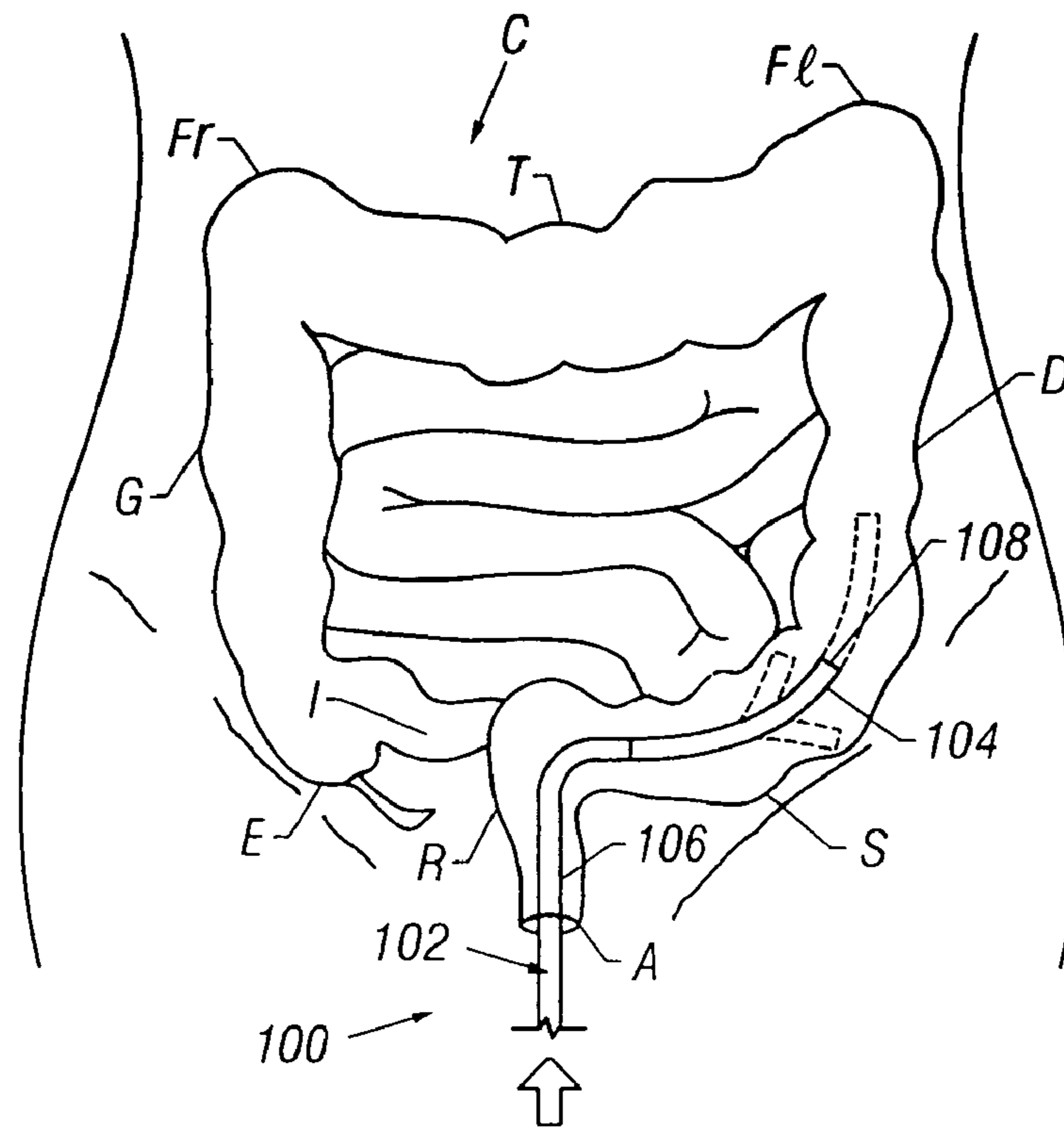
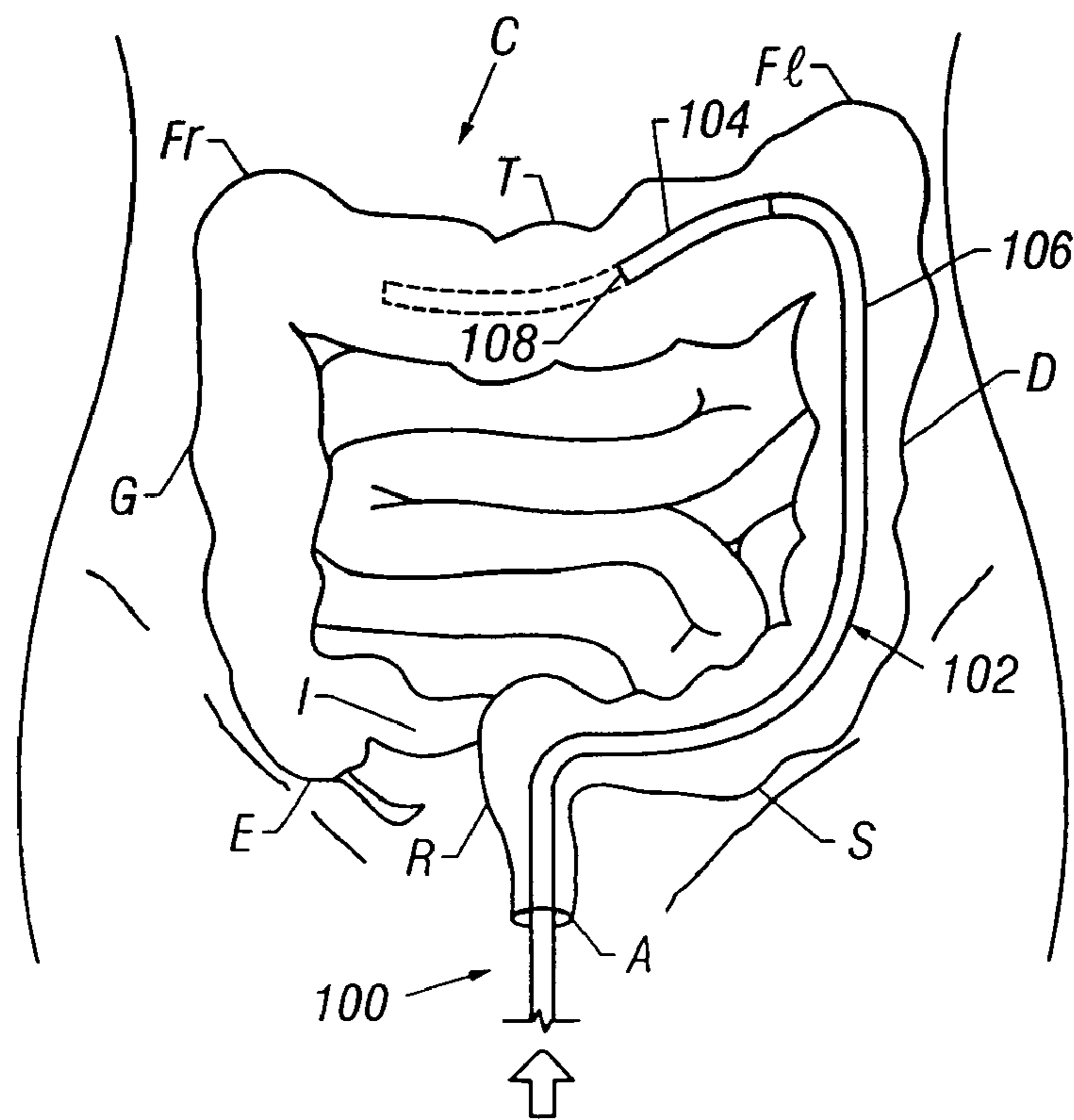
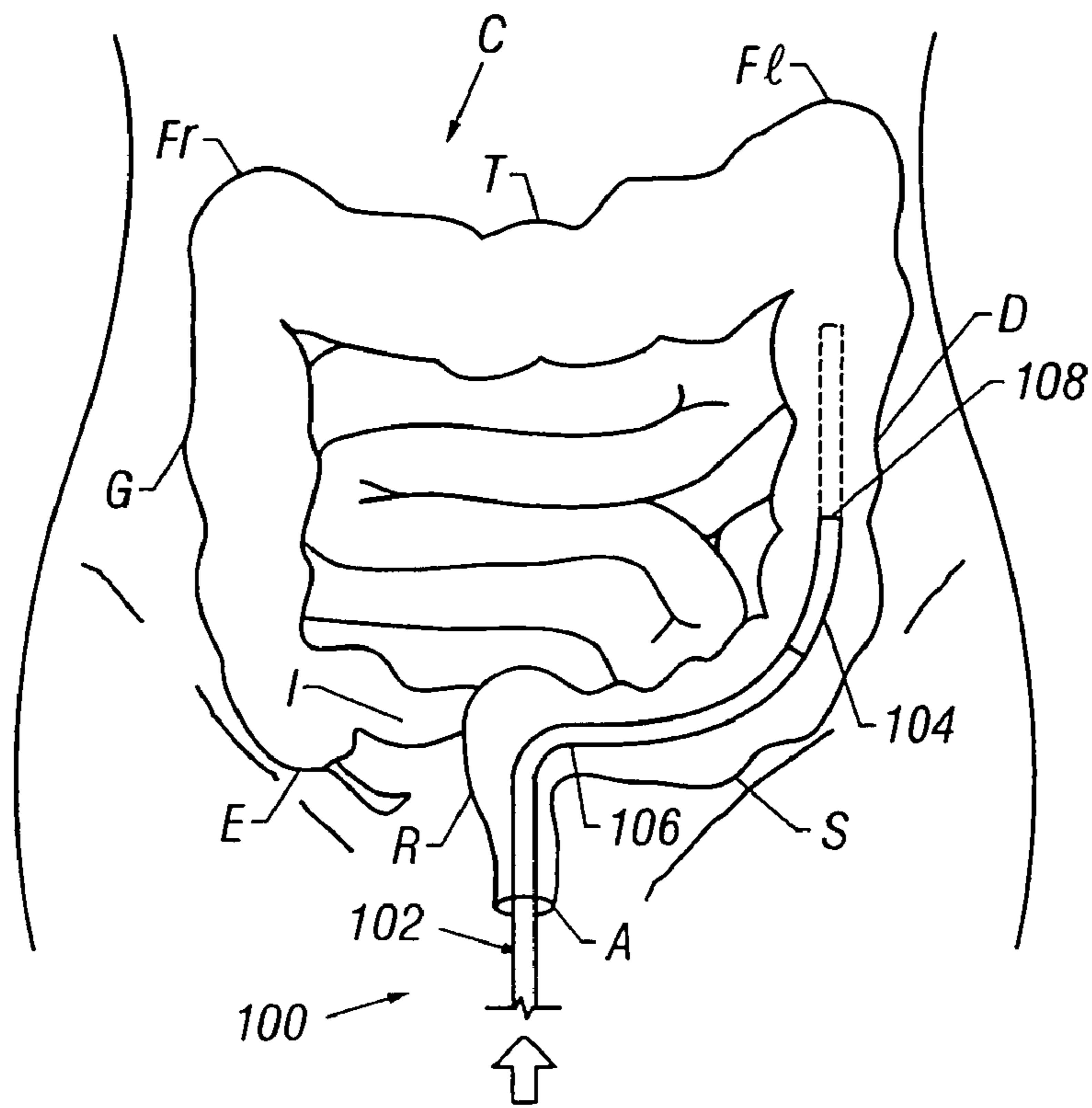

FIG. 9



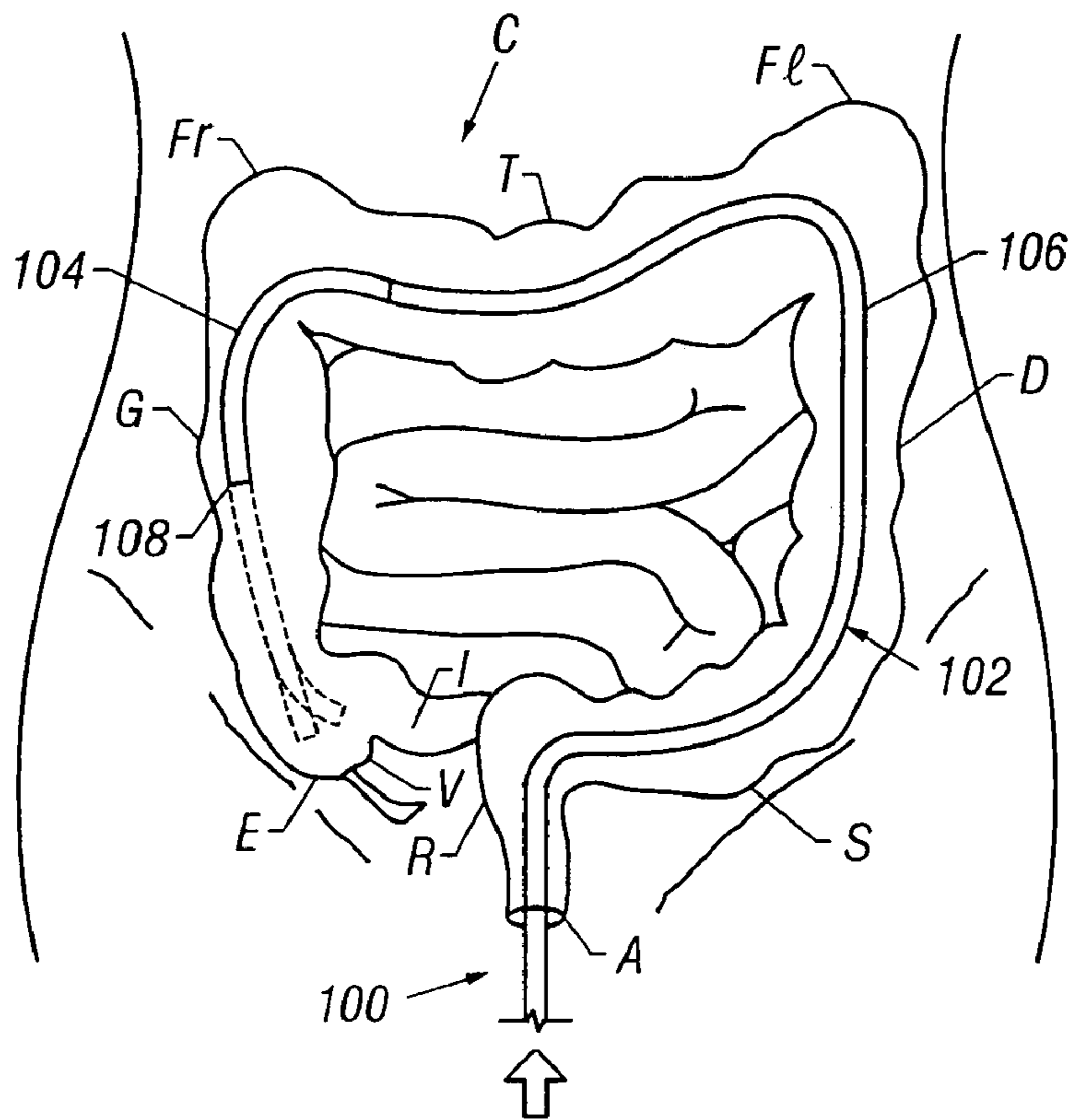

FIG. 12

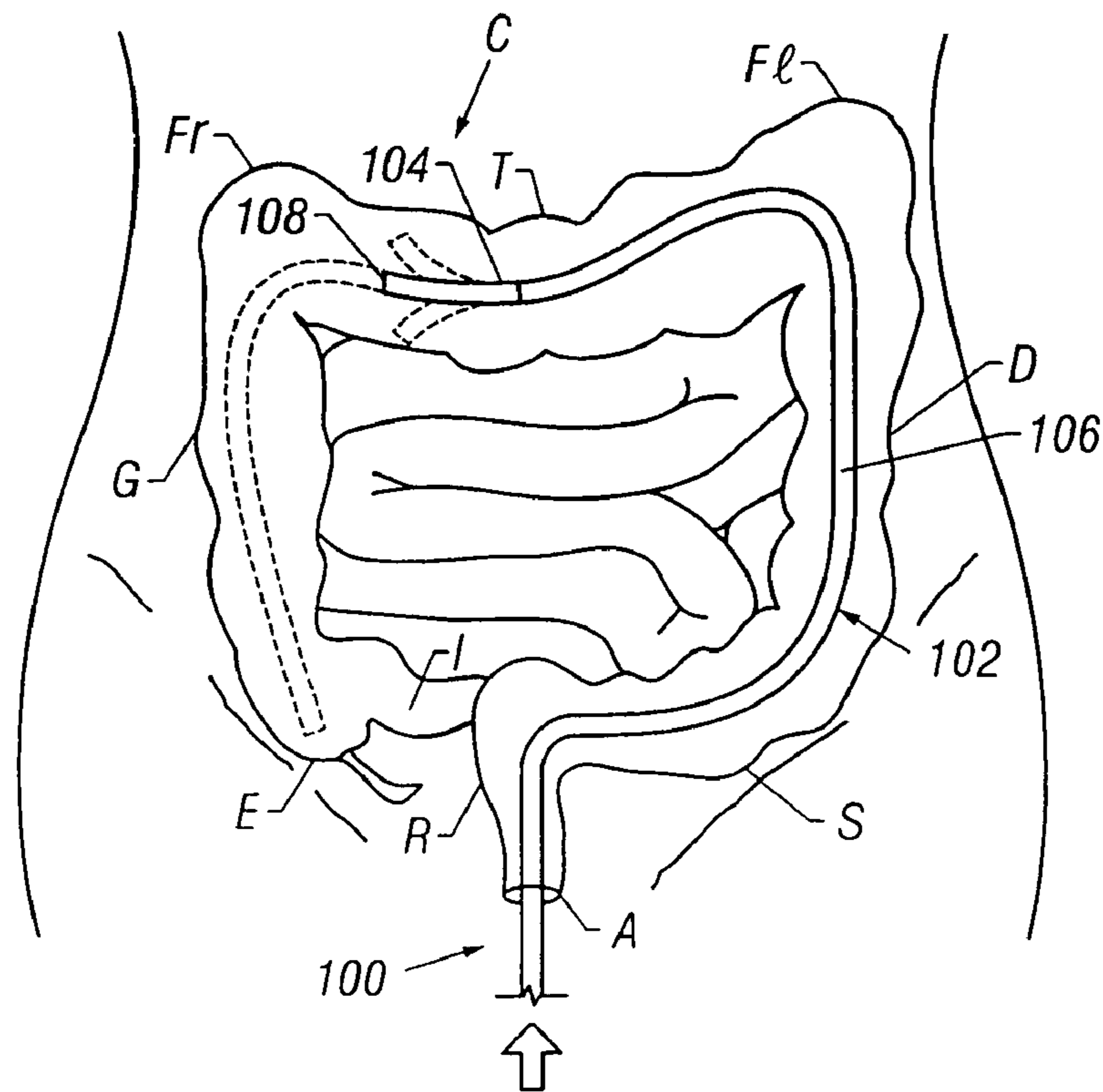

FIG. 13

STEERABLE ENDOSCOPE AND IMPROVED METHOD OF INSERTION

CROSS-REFERENCE TO OTHER APPLICATIONS

The present application is a continuation of U.S. patent application Ser. No. 10/229,189, filed Aug. 26, 2002, which is a continuation of U.S. patent application Ser. No. 09/790,204, filed Feb. 20, 2001, now U.S. Pat. No. 6,468,203, which claims priority of U.S. Provisional Patent Application Ser. No. 60/194,140, filed Apr. 3, 2000, each of the above applications is incorporated herein by reference for all purposes.

FIELD OF THE INVENTION

The present invention relates generally to endoscopes and endoscopic medical procedures. More particularly, it relates to a method and apparatus to facilitate insertion of a flexible endoscope along a tortuous path, such as for colonoscopic examination and treatment.

BACKGROUND OF THE INVENTION

An endoscope is a medical instrument for visualizing the interior of a patient's body. Endoscopes can be used for a variety of different diagnostic and interventional procedures, including colonoscopy, bronchoscopy, thoracoscopy, laparoscopy and video endoscopy.

Colonoscopy is a medical procedure in which a flexible endoscope, or colonoscope, is inserted into a patient's colon for diagnostic examination and/or surgical treatment of the colon. A standard colonoscope is typically 135-185 cm in length and 12-13 mm in diameter, and includes a fiberoptic imaging bundle, illumination fibers and one or two instrument channels that may also be used for insufflation or irrigation. The colonoscope is inserted via the patient's anus and is advanced through the colon, allowing direct visual examination of the colon, the ileocecal valve and portions of the terminal ileum. Insertion of the colonoscope is complicated by the fact that the colon represents a tortuous and convoluted path. Considerable manipulation of the colonoscope is often necessary to advance the colonoscope through the colon, making the procedure more difficult and time consuming and adding to the potential for complications, such as intestinal perforation. Steerable colonoscopes have been devised to facilitate selection of the correct path through the curves of the colon. However, as the colonoscope is inserted farther and farther into the colon, it becomes more difficult to advance the colonoscope along the selected path. At each turn, the wall of the colon must maintain the curve in the colonoscope. The colonoscope rubs against the mucosal surface of the colon along the outside of each turn. Friction and slack in the colonoscope build up at each turn, making it more and more difficult to advance and withdraw the colonoscope. In addition, the force against the wall of the colon increases with the buildup of friction. In cases of extreme tortuosity, it may become impossible to advance the colonoscope all of the way through the colon.

Steerable endoscopes, catheters and insertion devices for medical examination or treatment of internal body structures are described in the following U.S. patents, the disclosures of which are hereby incorporated by reference in their entirety: U.S. Pat. Nos. 4,753,223; 5,337,732; 5,662,587; 4,543,090; 5,383,852; 5,487,757 and 5,337,733.

SUMMARY OF THE INVENTION

In keeping with the foregoing discussion, the present invention takes the form of a steerable endoscope for negoti-

ating tortuous paths-through a patient's body. The steerable endoscope can be used for a variety of different diagnostic and interventional procedures, including colonoscopy, bronchoscopy, thoracoscopy, laparoscopy and video endoscopy. The steerable endoscope is particularly well suited for negotiating the tortuous curves encountered when performing a colonoscopy procedure.

The steerable endoscope has an elongated body with a manually or selectively steerable distal portion and an automatically controlled proximal portion. The selectively steerable distal portion can be selectively steered or bent up to a full 180 degree bend in any direction. A fiberoptic imaging bundle and one or more illumination fibers extend through the body from the proximal end to the distal end. Alternatively, the endoscope can be configured as a video endoscope with a miniaturized video camera, such as a CCD camera, which transmits images to a video monitor by a transmission cable or by wireless transmission. Optionally, the endoscope may include one or two instrument channels that may also be used for insufflation or irrigation.

A proximal handle attached to the elongate body includes an ocular for direct viewing and/or for connection to a video camera, a connection to an illumination source and one or more luer lock fittings that are connected to the instrument channels. The handle is connected to a steering control for selectively steering or bending the selectively steerable distal portion in the desired direction and to an electronic motion controller for controlling the automatically controlled proximal portion of the endoscope. An axial motion transducer is provided to measure the axial motion of the endoscope body as it is advanced and withdrawn. Optionally, the endoscope may include a motor or linear actuator for automatically advancing and withdrawing the endoscope.

The method of the present invention involves inserting the distal end of the endoscope body into a patient, either through a natural orifice or through an incision, and steering the selectively steerable distal portion to select a desired path. When the endoscope body is advanced, the electronic motion controller operates the automatically controlled proximal portion of the body to assume the selected curve of the selectively steerable distal portion. This process is repeated by selecting another desired path with the selectively steerable distal portion and advancing the endoscope body again. As the endoscope body is further advanced, the selected curves propagate proximally along the endoscope body. Similarly, when the endoscope body is withdrawn proximally, the selected curves propagate distally along the endoscope body. This creates a sort of serpentine motion in the endoscope body that allows it to negotiate tortuous curves along a desired path through or around and between organs within the body.

The method can be used for performing colonoscopy or other endoscopic procedures, such as bronchoscopy, thoracoscopy, laparoscopy and video endoscopy. In addition, the apparatus and methods of the present invention can be used for inserting other types of instruments, such as surgical instruments, catheters or introducers, along a desired path within the body.

BRIEF DESCRIPTION OF THE DRAWINGS

FIG. 1 shows a prior art colonoscope being employed for a colonoscopic examination of a patient's colon.

FIG. 2 shows a first embodiment of the steerable endoscope of the present invention.

FIG. 3 shows a second embodiment of the steerable endoscope of the present invention.

FIG. 4 shows a third embodiment of the steerable endoscope of the present invention.

FIG. 5 shows a fourth embodiment of the steerable endoscope of the present invention.

FIG. 6 shows a wire frame model of a section of the body of the endoscope in a neutral or straight position.

FIG. 7 shows the wire frame model of the endoscope body shown in FIG. 6 passing through a curve in a patient's colon.

FIGS. 8-13 show the endoscope of the present invention being employed for a colonoscopic examination of a patient's colon.

DETAILED DESCRIPTION OF THE INVENTION

FIG. 1 shows a prior art colonoscope 500 being employed for a colonoscopic examination of a patient's colon C. The colonoscope 500 has a proximal handle 506 and an elongate body 502 with a steerable distal portion 504. The body 502 of the colonoscope 500 has been lubricated and inserted into the colon C via the patient's anus A. Utilizing the steerable distal portion 504 for guidance, the body 502 of the colonoscope 500 has been maneuvered through several turns in the patient's colon C to the ascending colon G. Typically, this involves a considerable amount of manipulation by pushing, pulling and rotating the colonoscope 500 from the proximal end to advance it through the turns of the colon C. After the steerable distal portion 504 has passed, the wall of the colon C maintains the curve in the flexible body 502 of the colonoscope 500 as it is advanced. Friction develops along the body 502 of the colonoscope 500 as it is inserted, particularly at each turn in the colon C. Because of the friction, when the user attempts to advance the colonoscope 500, the body 502 tends to move outward at each curve, pushing against the wall of the colon C, which exacerbates the problem by increasing the friction and making it more difficult to advance the colonoscope 500. On the other hand, when the colonoscope 500 is withdrawn, the body 502 tends to move inward at each curve taking up the slack that developed when the colonoscope 500 was advanced. When the patient's colon C is extremely tortuous, the distal end of the body 502 becomes unresponsive to the user's manipulations, and eventually it may become impossible to advance the colonoscope 500 any farther. In addition to the difficulty that it presents to the user, tortuosity of the patient's colon also increases the risk of complications, such as intestinal perforation.

FIG. 2 shows a first embodiment of the steerable endoscope 100 of the present invention. The endoscope 100 has an elongate body 102 with a manually or selectively steerable distal portion 104 and an automatically controlled proximal portion 106. The selectively steerable distal portion 104 can be selectively steered or bent up to a full 180 degree bend in any direction. A fiberoptic imaging bundle 112 and one or more illumination fibers 114 extend through the body 102 from the proximal end 110 to the distal end 108. Alternatively, the endoscope 100 can be configured as a video endoscope with a miniaturized video camera, such as a CCD camera, positioned at the distal end 108 of the endoscope body 102. The images from the video camera can be transmitted to a video monitor by a transmission cable or by wireless transmission. Optionally, the body 102 of the endoscope 100 may include one or two instrument channels 116, 118 that may also be used for insufflation or irrigation. The body 102 of the endoscope 100 is highly flexible so that it is able to bend around small diameter curves without buckling or kinking. When configured for use as a colonoscope, the body 102 of the endoscope 100 is typically from 135 to 185 cm in length and approximately 12-13 mm in diameter. The endoscope

100 can be made in a variety of other sizes and configurations for other medical and industrial applications.

A proximal handle 120 is attached to the proximal end 110 of the elongate body 102. The handle 120 includes an ocular 124 connected to the fiberoptic imaging bundle 112 for direct viewing and/or for connection to a video camera 126. The handle 120 is connected to an illumination source 128 by an illumination cable 134 that is connected to or continuous with the illumination fibers 114. A first luer lock fitting, 130 and a second luer lock fitting 132 on the handle 120 are connected to the instrument channels 116, 118.

The handle 120 is connected to an electronic motion controller 140 by way of a controller cable 136. A steering control 122 is connected to the electronic motion controller 140 by way of a second cable 13 M. The steering control 122 allows the user to selectively steer or bend the selectively steerable distal portion 104 of the body 102 in the desired direction. The steering control 122 may be a joystick controller as shown, or other known steering control mechanism. The electronic motion controller 140 controls the motion of the automatically controlled proximal portion 106 of the body 102. The electronic motion controller 140 may be implemented using a motion control program running on a microcomputer or using an application-specific motion controller. Alternatively, the electronic motion controller 140 may be implemented using, a neural network controller.

An axial motion transducer 150 is provided to measure the axial motion of the endoscope body 102 as it is advanced and withdrawn. The axial motion transducer 150 can be made in many possible configurations. By way of example, the axial motion transducer 150 in FIG. 2 is configured as a ring 152 that surrounds the body 102 of the endoscope 100. The axial motion transducer 150 is attached to a fixed point of reference, such as the surgical table or the insertion point for the endoscope 100 on the patient's body. As the body 102 of the endoscope 100 slides through the axial motion transducer 150, it produces a signal indicative of the axial position of the endoscope body 102 with respect to the fixed point of reference and sends a signal to the electronic motion controller 140 by telemetry or by a cable (not shown). The axial motion transducer 150 may use optical, electronic or mechanical means to measure the axial position of the endoscope body 102. Other possible configurations for the axial motion transducer 150 are described below.

FIG. 3 shows a second embodiment of the endoscope 100 of the present invention. As in the embodiment of FIG. 2, the endoscope 100 has an elongate body 102 with a selectively steerable distal portion 104 and an automatically controlled proximal portion 106. The steering control 122 is integrated into proximal handle 120 in the form of one or two dials for selectively steering, the selectively steerable distal portion 104 of the endoscope 100. Optionally, the electronic motion controller 140 may be miniaturized and integrated into proximal handle 120, as well. In this embodiment, the axial motion transducer 150 is configured with a base 154 that is attachable to a fixed point of reference, such as the surgical table. A first roller 156 and a second roller 158 contact the exterior of the endoscope body 102. A multi-turn potentiometer 160 or other motion transducer is connected to the first roller 156 to measure the axial motion of the endoscope body 102 and to produce a signal indicative of the axial position.

The endoscope 100 may be manually advanced or withdrawn by the user by grasping the body 102 distal to the axial motion transducer 150. Alternatively, the first roller 156 and/or second roller 158 may be connected to a motor 162 for automatically advancing and withdrawing the body 102 of the endoscope 100.

5

FIG. 4 shows a third embodiment of the endoscope 100 of the present invention, which utilizes an elongated housing 170 to organize and contain the endoscope 100. The housing 170 has a base 172 with a linear track 174 to guide the body 102 of the endoscope 100. The housing 170 may have an axial motion transducer 150' that is configured as a linear motion transducer integrated into the linear track 174. Alternatively, the housing, 170 may have an axial motion transducer 150" configured similarly to the axial motion transducer 150 in FIG. 2 or 3. The endoscope 100 may be manually advanced or withdrawn by the user by grasping the body 102 distal to the housing 170. Alternatively, the housing 170 may include a motor 176 or other linear motion actuator for automatically advancing and withdrawing the body 102 of the endoscope 100. In another alternative configuration, a motor with friction wheels, similar to that described above in connection with FIG. 3, may be integrated into the axial motion transducer 150".

FIG. 5 shows a fourth embodiment of the endoscope 100 of the present invention, which utilizes a rotary housing 180 to organize and contain the endoscope 100. The housing 180 has a base 182 with a rotating drum 184 to guide the body 102 of the endoscope 100. The housing 180 may have an axial motion transducer 150'" that is configured as a potentiometer connected to the pivot axis 186 of the rotating drum 184. Alternatively, the housing 180 may have an axial motion transducer 150" configured similarly to the axial motion transducer 150 in FIG. 2 or 3. The endoscope 100 may be manually advanced or withdrawn by the user by grasping the body 102 distal to the housing 180. Alternatively, the housing 180 may include a motor 188 connected to the rotating drum 184 for automatically advancing and withdrawing the body 102 of the endoscope 100. In another alternative configuration, a motor with friction wheels, similar to that described above in connection with FIG. 3, may be integrated into the axial motion transducer 150".

FIG. 6 shows a wire frame model of a section of the body 102 of the endoscope 100 in a neutral or straight position. Most of the internal structure of the endoscope body 102 has been eliminated in this drawing for the sake of clarity. The endoscope body 102 is divided up into sections 1, 2, 3 . . . 10, etc. The geometry of each section is defined by four length measurements along the a, b, c and d axes. For example, the geometry of section 1 is defined by the four length measurements l_{1a} , l_{1b} , l_{1c} , l_{1d} , and the geometry of section 2 is defined by the four length measurements l_{2a} , l_{2b} , l_{2c} , l_{2d} , etc. Preferably, each of the length measurements is individually controlled by a linear actuator (not shown). The linear actuators may utilize one of several different operating principles. For example, each of the linear actuators may be a self-heating NiTi alloy linear actuator or an electrorheological plastic actuator, or other known mechanical, pneumatic, hydraulic or electromechanical actuator. The geometry of each section may be altered using the linear actuators to change the four length measurements along the a, b, c and d axes. Preferably, the length measurements are changed in complementary pairs to selectively bend the endoscope body 102 in a desired direction. For example, to bend the endoscope body 102 in the direction of the a axis, the measurements l_{1a} , l_{2a} , l_{3a} . . . l_{10a} would be shortened and the measurements l_{1b} , l_{2b} , l_{3b} . . . l_{10b} would be lengthened an equal amount. The amount by which these measurements are changed determines the radius of the resultant curve.

In the selectively steerable distal portion 104 of the endoscope body 102, the linear actuators that control the a, b, c and d axis measurements of each section are selectively controlled by the user through the steering control 122. Thus, by

6

appropriate control of the a, b, c and d axis measurements, the selectively steerable distal portion 104 of the endoscope body 102 can be selectively steered or bent up to a full 180 degrees in any direction.

In the automatically controlled proximal portion 106, however, the a, b, c and d axis measurements of each section are automatically controlled by the electronic motion controller 140, which uses a curve propagation method to control the shape of the endoscope body 102. To explain how the curve propagation method operates, FIG. 7 shows the wire frame model of a part of the automatically controlled proximal portion 106 of the endoscope body 102 shown in FIG. 6 passing, through a curve in a patient's colon C. For simplicity, an example of a two-dimensional curve is shown and only the a and b axes will be considered. In a three-dimensional curve all four of the a, b, c and d axes would be brought into play.

In FIG. 7, the endoscope body 102 has been maneuvered through the curve in the colon C with the benefit of the selectively steerable distal portion 104 (this part of the procedure is explained in more detail below) and now the automatically controlled proximal portion 106 resides in the curve. Sections 1 and 2 are in a relatively straight part of the colon C, therefore $l_{1a}=l_{1b}$ and $l_{2a}=l_{2b}$. However, because sections 3-7 are in the S-shaped curved section, $l_{3a}<l_{3b}$, $l_{4a}<l_{4b}$ and $l_{5a}<l_{5b}$, but $l_{6a}>l_{6b}$, $l_{7a}>l_{7b}$ and $l_{8a}>l_{8b}$. When the endoscope body 102 is advanced distally by one unit, section 1 moves into the position marked 1', section 2 moves into the position previously occupied by section 1, section 3 moves into the position previously occupied by section 2, etc. The axial motion transducer 150 produces a signal indicative of the axial position of the endoscope body 102 with respect to a fixed point of reference and sends the signal to the electronic motion controller 140. Under control of the electronic motion controller 140, each time the endoscope body 102 advances one unit, each section in the automatically controlled proximal portion 106 is signaled to assume the shape of the section that previously occupied the space that it is now in. Therefore, when the endoscope body 102 is advanced to the position marked 1', $l_{1a}=l_{1b}$, $l_{2a}=l_{2b}$, $l_{3a}=l_{3b}$, $l_{4a}<l_{4b}$, $l_{5a}<l_{5b}$, $l_{6a}<l_{6b}$, $l_{7a}>l_{7b}$ and $l_{8a}>l_{8b}$, and $l_{9a}>l_{9b}$, when the endoscope body 102 is advanced to the position marked 1", $l_{1a}=l_{1b}$, $l_{2a}=l_{2b}$, $l_{3a}=l_{3b}$, $l_{4a}=l_{4b}$, $l_{5a}<l_{5b}$, $l_{6a}<l_{6b}$, $l_{7a}<l_{7b}$, $l_{8a}>l_{8b}$, $l_{9a}>l_{9b}$, and $l_{10a}>l_{10b}$. Thus, the S-shaped curve propagates proximally along the length of the automatically controlled proximal portion 106 of the endoscope body 102. The S-shaped curve appears to be fixed in space, as the endoscope body 102 advances distally.

Similarly, when the endoscope body 102 is withdrawn proximally, each time the endoscope body 102 is moved proximally by one unit, each section in the automatically controlled proximal portion 106 is signaled to assume the shape of the section that previously occupied the space that it is now in. The S-shaped curve propagates distally along the length of the automatically controlled proximal portion 106 of the endoscope body 102, and the S-shaped curve appears to be fixed in space, as the endoscope body 102 withdraws proximally.

Whenever the endoscope body 102 is advanced or withdrawn, the axial motion transducer 150 detects the change in position and the electronic motion controller 140 propagates the selected curves proximally or distally along the automatically controlled proximal portion 106 of the endoscope body 102 to maintain the curves in a spatially fixed position. This allows the endoscope body 102 to move through tortuous curves without putting unnecessary force on the wall of the colon C.

FIGS. 8-13 show the endoscope 100 of the present invention being employed for a colonoscopic examination of a

patient's colon. In FIG. 8, the endoscope body 102 has been lubricated and inserted into the patient's colon C through the anus A. The distal end 108 of the endoscope body 102 is advanced through the rectum R until the first turn in the colon C is reached, as observed through the ocular 124 or on a video monitor. To negotiate the turn, the selectively steerable distal portion 104 of the endoscope body 102 is manually steered toward the sigmoid colon S by the user through the steering control 122. The control signals from the steering control 122 to the selectively steerable distal portion 104 are monitored by the electronic motion controller 140. When the correct curve of the selectively steerable distal portion 104 for advancing the distal end 108 of the endoscope body 102 into the sigmoid colon S has been selected, the curve is logged into the memory of the electronic motion controller 140 as a reference. This step can be performed in a manual mode, in which the user gives a command to the electronic motion controller 140 to record the selected curve, using keyboard commands or voice commands. Alternatively, this step can be performed in an automatic mode, in which the user signals to the electronic motion controller 140 that the desired curve has been selected by advancing the endoscope body 102 distally.

Whether operated in manual mode or automatic mode, once the desired curve has been selected with the selectively steerable distal portion 104, the endoscope body 102 is advanced distally and the selected curve is propagated proximally along the automatically controlled proximal portion 106 of the endoscope body 102 by the electronic motion controller 140, as described above. The curve remains fixed in space while the endoscope body 102 is advanced distally through the sigmoid colon S. In a particularly tortuous colon, the selectively steerable distal portion 104 may have to be steered through multiple curves to traverse the sigmoid colon S.

As illustrated in FIG. 9, the user may stop the endoscope 100 at any point for examination or treatment of the mucosal surface or any other features within the colon C. The selectively steerable distal portion 104 may be steered in any direction to examine the inside of the colon C. When the user has completed the examination of the sigmoid colon S, the selectively steerable distal portion 104 is steered in a superior direction toward the descending colon D. Once the desired curve has been selected with the selectively steerable distal portion 104, the endoscope body 102 is advanced distally into the descending colon D, and the second curve as well as the first curve are propagated proximally along the automatically controlled proximal portion 106 of the endoscope body 102, as shown in FIG. 10.

If, at any time, the user decides that the path taken by the endoscope body 102 needs to be revised or corrected, the endoscope 100 may be withdrawn proximally and the electronic motion controller 140 commanded to erase the previously selected curve. This can be done manually using keyboard commands or voice commands or automatically by programming the electronic motion controller 140 to go into a revise mode when the endoscope body 102 is withdrawn a certain distance. The revised or corrected curve is selected using the selectively steerable distal portion 104, and the endoscope body 102 is advanced as described before.

The endoscope body 102 is advanced through the descending colon D until it reaches the left (splenic) flexure F_1 of the colon. Here, in many cases, the endoscope body 102 must negotiate an almost 180 degree hairpin turn. As before, the desired curve is selected using the selectively steerable distal portion 104, and the endoscope body 102 is advanced distally through the transverse colon T, as shown in FIG. 11. Each of the previously selected curves is propagated proximally along

the automatically controlled proximal portion 106 of the endoscope body 102. The same procedure is followed at the right (hepatic) flexure Fr of the colon and the distal end 108 of the endoscope body 102 is advanced through the ascending colon G to the cecum E, as shown in FIG. 12. The cecum E, the ileocecal valve V and the terminal portion of the ileum I can be examined from this point using the selectively steerable distal portion 104 of the endoscope body 102.

FIG. 13 shows the endoscope 100 being, withdrawn through the colon C. As the endoscope 100 is withdrawn, the endoscope body 102 follows the previously selected curves by propagating the curves distally along the automatically controlled proximal portion 106, as described above. At any point, the user may stop the endoscope 100 for examination or treatment of the mucosal surface or any other features within the colon C using the selectively steerable distal portion 104 of the endoscope body 102.

In one preferred method according to the present invention, the electronic motion controller 140 includes an electronic memory in which is created a three-dimensional mathematical model of the patient's colon or other anatomy through which the endoscope body 102 is maneuvered. The three-dimensional model can be annotated by the operator to record the location of anatomical landmarks, lesions, polyps, biopsy samples and other features of interest. The three-dimensional model of the patient's anatomy can be used to facilitate reinsertion of the endoscope body 102 in subsequent procedures. In addition, the annotations can be used to quickly find the location of the features of interest. For example, the three-dimensional model can be annotated with the location where a biopsy sample was taken during an exploratory endoscopy. The site of the biopsy sample can be reliably located again in follow-up procedures to track the progress of a potential disease process and/or to perform a therapeutic procedure at the site.

In one particularly preferred variation of this method, the electronic motion controller 140 can be programmed, based on the three-dimensional model in the electronic memory, so that the endoscope body 102 will automatically assume the proper shape to follow the desired path as it is advanced through the patient's anatomy. In embodiments of the steerable endoscope 100 that are configured for automatically advancing and withdrawing the endoscope body 102, as described above in connection with FIGS. 3, 4 and 5, the endoscope body 102 can be commanded to advance automatically through the patient's anatomy to the site of a previously noted lesion or other point of interest based on the three-dimensional model in the electronic memory.

Imaging software would allow the three-dimensional model of the patient's anatomy obtained using the steerable endoscope 100 to be viewed on a computer monitor or the like. This would facilitate comparisons between the three-dimensional model and images obtained with other imaging modalities, for example fluoroscopy, radiography, ultrasonography, magnetic resonance imaging (MRI), computed tomography (CT scan), electron beam tomography or virtual colonoscopy. Conversely, images from these other imaging modalities can be used to map out an approximate path or trajectory to facilitate insertion of the endoscope body 102. In addition, images from other imaging modalities can be used to facilitate locating suspected lesions with the steerable endoscope 100. For example, images obtained using a barium-contrast radiograph of the colon can be used to map out an approximate path to facilitate insertion of the endoscope body 102 into the patient's colon. The location and depth of any suspected lesions seen on the radiograph can be

noted so that the endoscope body **102** can be quickly and reliably guided to the vicinity of the lesion.

Imaging modalities that provide three-dimensional information, such as biplanar fluoroscopy, CT or MRI, can be used to program the electronic motion controller **140** so that the endoscope body **102** will automatically assume the proper shape to follow the desired path as it is advanced through the patient's anatomy. In embodiments of the steerable endoscope **100** that are configured for automatically advancing and withdrawing the endoscope body **102**, the endoscope body **102** can be commanded to advance automatically though the patient's anatomy along the desired path as determined by the three-dimensional imacrinc, information. Similarly, the endoscope body **102** can be commanded to advance automatically to the site of a suspected lesion or other point of interest noted on the images.

Although the endoscope of the present invention has been described for use as a colonoscope, the endoscope can be configured for a number of other medical and industrial applications. In addition, the present invention can also be configured as a catheter, cannula, surgical instrument or introducer sheath that uses the principles of the invention for navigating through tortuous body channels.

In a variation of the method that is particularly applicable to laparoscopy or thoracoscopy procedures, the steerable endoscope **100** can be selectively maneuvered along a desired path around and between organs in a patient's body cavity. The distal end **108** of the endoscope **100** is g inserted into the patient's body cavity through a natural opening, through a surgical incision or through a surgical cannula or introducer. The selectively steerable distal portion **104** can be used to explore and examine the patient's body cavity and to select a path around and between the patient's organs. The electronic motion controller **140** can be used to control the automatically controlled proximal portion **106** of the endoscope body **102** to follow the selected path and, if necessary, to return to a desired location using the three-dimensional model in the electronic memory of the electronic motion controller **140**.

While the present invention has been described herein with respect to the exemplary embodiments and the best mode for practicing the invention, it will be apparent to one of ordinary skill in the art that man modifications, improvements and subcombinations of the various embodiments, adaptations and variations can be made to the invention without departing from the spirit and scope thereof.

I claim:

1. An instrument maneuvering system comprising:
an elongate body comprising a distal portion and a proximal portion;
a motion controller configured to control motion of the distal and proximal portions of the elongate body; and

a memory having stored therein a three-dimensional model of a patient's anatomy;

wherein the three-dimensional model is constructed from medical imaging modality information;

wherein the motion controller is configured to identify a desired path in the three-dimensional model; and

wherein the motion controller is configured to steer the distal portion of the elongate body along the desired path and to propagate a curve of the distal portion of the elongate body into the proximal portion of the elongate body as the elongate body is inserted into the patient.

2. The system of claim **1**:

wherein the three-dimensional model comprises anatomical feature of interest information; and

wherein the motion controller is configured to automatically advance the elongate body into the patient to reach the anatomical feature of interest.

3. The system of claim **1**:

wherein the three-dimensional model comprises anatomical feature of interest information; and

wherein the anatomical feature of interest information is annotated in the three-dimensional model by a system operator.

4. The system of claim **1**:

wherein the three-dimensional model comprises anatomical feature of interest information; and

wherein the anatomical feature of interest information is annotated in the three-dimensional model from the medical imaging modality information.

5. The system of claim **1**:

wherein the imaging modality is selected from a group consisting of fluoroscopy, radiography, ultrasonography, magnetic resonance imaging, computed tomography, electron beam tomography, and virtual colonoscopy.

6. The system of claim **1**:

wherein the motion controller is configured to withdraw the elongate body along the desired path to a desired location identified in the three-dimensional model.

7. The system of claim **1**:

wherein the elongate body is selected from a group consisting of an endoscope, a colonoscope, a catheter, a cannula, a surgical instrument, and an introducer sheath.

8. The system of claim **1**:

wherein the desired path comprises a path around an organ.

9. The system of claim **1**:

wherein the desired path comprises a path between two organs.

10. The system of claim **1**:

wherein the motion controller is configured to automatically advance the elongate body into the patient.

* * * * *