



US008002746B2

(12) **United States Patent**
Erskine

(10) **Patent No.:** **US 8,002,746 B2**
(45) **Date of Patent:** **Aug. 23, 2011**

(54) **WINGED NEEDLE WITH NEEDLE SHIELD**

(75) Inventor: **Timothy J. Erskine**, Sandy, UT (US)
(73) Assignee: **Erskine Medical LLC**, High Falls, NY (US)
(*) Notice: Subject to any disclaimer, the term of this patent is extended or adjusted under 35 U.S.C. 154(b) by 391 days.

(21) Appl. No.: **11/817,687**

(22) PCT Filed: **Mar. 6, 2006**

(86) PCT No.: **PCT/US2006/007912**

§ 371 (c)(1),
(2), (4) Date: **Sep. 4, 2007**

(87) PCT Pub. No.: **WO2006/096636**

PCT Pub. Date: **Sep. 14, 2006**

(65) **Prior Publication Data**

US 2008/0195055 A1 Aug. 14, 2008

Related U.S. Application Data

(60) Provisional application No. 60/659,226, filed on Mar. 7, 2005, provisional application No. 60/659,217, filed on Mar. 7, 2005, provisional application No. 60/659,213, filed on Mar. 7, 2005, provisional application No. 60/714,954, filed on Sep. 7, 2005.

(51) **Int. Cl.**
A61M 5/00 (2006.01)
A61M 5/32 (2006.01)

(52) **U.S. Cl.** **604/110**; 604/198

(58) **Field of Classification Search** 604/110,
604/164.01, 192, 193, 198

See application file for complete search history.

(56) **References Cited**

U.S. PATENT DOCUMENTS

4,588,398 A 5/1986 Daugherty et al.
4,596,563 A 6/1986 Pande
4,755,170 A 7/1988 Golden
4,762,516 A 8/1988 Luther et al.
4,778,453 A 10/1988 Lopez
4,790,828 A 12/1988 Dombrowski et al.

(Continued)

FOREIGN PATENT DOCUMENTS

CN 1145813 A 3/1997

(Continued)

OTHER PUBLICATIONS

Erskine, Australian IP Examination Report No. 2 dated Mar. 3, 2010, Reference No. 30355386/MRF/TLG/tzs, Application No. 2006220690, 2 pages.

(Continued)

Primary Examiner — Theodore Stigell

Assistant Examiner — Bradley Osinski

(74) *Attorney, Agent, or Firm* — Hoffman Warnick LLC

(57) **ABSTRACT**

A winged needle set is disclosed. The winged needle set has a housing and opposed wings which can be grasped between the fingers for insertion of the needle into a body. The winged needle set has a finned member which is rotatable about the axis of the needle. Rotation of the finned member towards one of the wings actuates a needle shield, which moves along the needle in the distal direction. In one embodiment, the needle shield has includes a blocking object (such as a ball), a biasing spring and a holder for the blocking object.

16 Claims, 10 Drawing Sheets

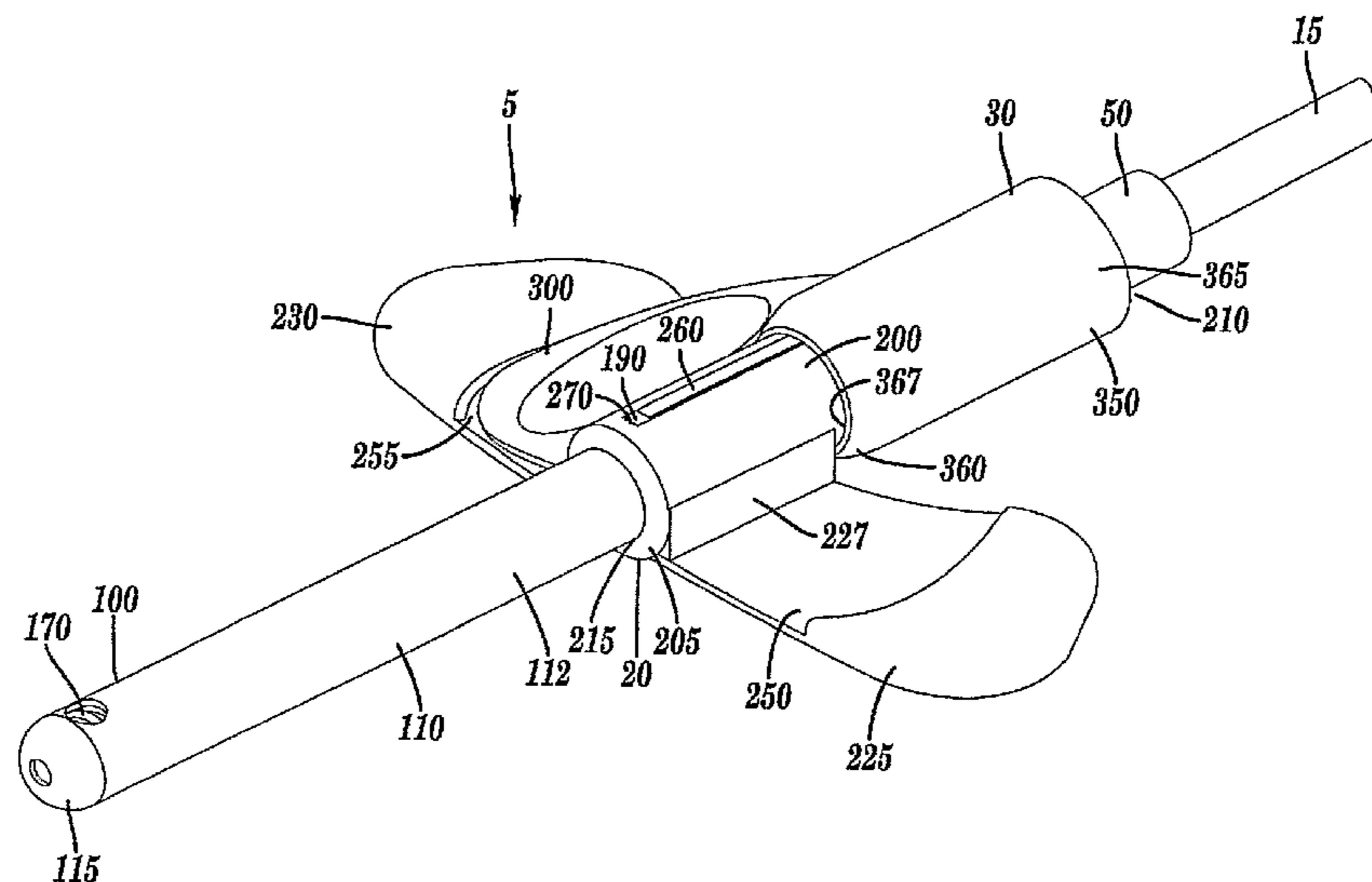

U.S. PATENT DOCUMENTS

4,832,696	A	5/1989	Luther et al.	
4,834,718	A	5/1989	McDonald	
4,846,809	A	7/1989	Sims	
4,887,998	A	12/1989	Martin et al.	
4,927,414	A	5/1990	Kulli	
4,929,241	A	5/1990	Kulli	
4,931,048	A	6/1990	Lopez	
4,944,725	A	7/1990	McDonald	
4,952,207	A	8/1990	Lemieux	
4,978,344	A	12/1990	Dombrowski et al.	
5,049,136	A	9/1991	Johnson	
5,059,180	A	10/1991	McLees	
5,215,528	A	6/1993	Purdy et al.	
RE34,416	E	10/1993	Lemieux	
5,261,895	A	11/1993	Kablik	
5,304,151	A	4/1994	Kuracina	
5,322,517	A	6/1994	Sircom et al.	
5,328,482	A	7/1994	Sircom et al.	
5,334,158	A	8/1994	McLees	
5,344,408	A	9/1994	Partika	
5,458,658	A	10/1995	Sircom	
5,558,651	A	9/1996	Crawford et al.	
5,601,536	A	2/1997	Crawford et al.	
5,611,781	A	3/1997	Sircom et al.	
5,662,610	A	9/1997	Sircom	
5,690,619	A	11/1997	Erskine	
5,697,907	A	12/1997	Gaba	
5,700,250	A	12/1997	Erskine	
5,795,339	A	8/1998	Erskine	
5,879,337	A	3/1999	Kuracina et al.	
6,001,080	A	12/1999	Kuracina et al.	
6,221,047	B1	4/2001	Greene et al.	
6,443,929	B1	9/2002	Kuracina	
6,629,959	B2	10/2003	Kuracina et al.	
6,659,984	B2 *	12/2003	Maclean Crawford et al.	604/263
6,689,102	B2	2/2004	Greene	
6,695,814	B2	2/2004	Greene et al.	
6,743,186	B2 *	6/2004	Crawford et al.	600/583
6,860,871	B2	3/2005	Kuracina et al.	
7,144,387	B2	12/2006	Millerd	
7,322,963	B2	1/2008	Goh	
2003/0036731	A1	2/2003	Wilkinson et al.	
2003/0216687	A1	11/2003	Hwang	
2003/0220587	A1	11/2003	Swenson	
2004/0225262	A1	11/2004	Fathallah et al.	
2005/0119627	A1	6/2005	Crawford	
2008/0171986	A1	7/2008	Baid	

FOREIGN PATENT DOCUMENTS

CN	1547493	A	11/2004
DE	3802353	A1	8/1989
EP	0749761	A1	12/1996
EP	0750916	A2	1/1997
EP	1369142	B1	8/2005
EP	2016964	A1	1/2009
FR	2767480	A1	2/1999
JP	2002330946	A	11/2002
JP	2002539897	T	11/2002
TW	M243216		9/2004
WO	03011381	A1	2/2003
WO	2006096633	A1	9/2006
WO	2006096634	A1	9/2006
WO	2006096635	A1	9/2006

OTHER PUBLICATIONS

Erskine, Canadian Application No. 2,599,943, Office Action dated Nov. 20, 2009, 2 pages.
 Erskine, Chinese Application No. 200680007590, Office Action dated Aug. 21, 2009, 11 pages.
 Erskine, Australian Application No. 2006220691, Notice of Acceptance dated Jun. 9, 2010, 2 pages.
 Erskine, Canadian Application No. 2,599,945, Office Action dated Nov. 13, 2009, 2 pages.
 Erskine, Chinese Application No. 200680007484, Notification to Grant Patent Right dated Jun. 11, 2010, 4 pages.

Erskine, Australian Application No. 2006220692, Examiners First Report on Patent Application dated Oct. 21, 2008, 2 pages.
 Erskine, Canadian Application No. 2,599,955, Office Action dated Mar. 5, 2010, 2 pages.
 Erskine, Chinese Application No. 200680007485.0, Office Action dated Jun. 19, 2009, 6 pages.
 Erskine, Chinese Application No. 200680007485.0, Notification to Grant Patent Right dated Jun. 4, 2010, 5 pages.
 Erskine, Japanese Application No. P2008-500805, Office Action dated Apr. 20, 2010, 4 pages.
 Erskine, Malaysia Application No. PI 20071465, Substantive Examination Report dated Apr. 30, 2010, 3 pages.
 Patent Cooperation Treaty, PCT/US06/07912, PCT International Preliminary Report on Patentability, dated Sep. 12, 2007, 5 pages.
 Patent Cooperation Treaty, PCT/US06/07912, PCT International Search Report and Written Opinion, dated Jun. 26, 2006, 8 pages.
 Erskine, Taiwanese Application No. 095107584, Decision to Grant Patent dated Mar. 4, 2009, 5 pages.
 Erskine, Australian Application No. 2006220690, Notice of Acceptance dated Jun. 15, 2010, 3 pages.
 Erskine, U.S. Appl. No. 11/817,891, Office Communication dated Oct. 19, 2009, 10 pages.
 Erskine, Australian Application No. 2006220689, Examiners First Report on Patent Application dated Jan. 15, 2009, 3 pages.
 Erskine, Australian Application No. 2006220689, Patent Granted dated Jun. 18, 2010, 3 pages.
 Erskine, Canadian Application No. 2,599,938, Office Action dated Feb. 23, 2010, 2 pages.
 Erskine, Chinese Application No. 200680007548.2, Office Action dated Sep. 4, 2009, 4 pages.
 Erskine, Chinese Application No. 200680007548.2, Notification to Grant Patent Right dated Jun. 12, 2010, 4 pages.
 Erskine, Japanese Application No. P2008-500802, Office Action dated Jun. 29, 2010, 6 pages.
 Erskine, Malaysia Application No. PI 20071468, Substantive Examination Report dated Apr. 16, 2010, 2 pages.
 Patent Cooperation Treaty, PCT/US06/07910, PCT International Preliminary Report on Patentability, dated Jul. 3, 2007, 20 pages.
 Patent Cooperation Treaty, PCT/US06/07909, PCT International Search Report and Written Opinion, dated Jun. 26, 2006, 9 pages.
 Erskine, Taiwanese Application No. 095107593, Decision to Grant Patent dated Dec. 11, 2009, 5 pages.
 Patent Cooperation Treaty, PCT/US09/036197, PCT International Search Report and Written Opinion dated Apr. 28, 2009, 14 pages.
 Patent Cooperation Treaty, PCT/US09/038246, PCT International Search Report and Written Opinion dated May 20, 2009, 11 pages.
 Erskine, Australian Application No. 2006220690, Examiner's First Report on Patent dated Nov. 11, 2008, 3 pages.
 Erskine, Chinese Application No. 200680007590, Office Action dated May 21, 2010, 4 pages.
 Erskine, European Application No. EP06737126, Supplementary European Search Report dated Feb. 11, 2010, 4 pages.
 Patent Cooperation Treaty, PCT/US06/07910, PCT International Search Report and Written Opinion, dated Jul. 5, 2006, 8 pages.
 Erskine, Taiwanese Application No. 095107587, Office Action dated Oct. 12, 2009, 12 pages.
 Erskine, Australian Application No. 2006220691, Examiner's First Report on Patent dated Jan. 19, 2009, 2 pages.
 Erskine, Chinese Application No. 200680007484, Office Action dated Aug. 21, 2009, 13 pages.
 Erskine, Taiwanese Application No. 095107585, Office Action dated Apr. 6, 2009, 9 pages.
 Erskine, Taiwanese Application No. 095107585, Office Action dated Oct. 15, 2009, 7 pages.
 Erskine, European Application EP06737125, Supplementary European Search Report dated Feb. 10, 2010, 7 pages.
 Patent Cooperation Treaty, PCT/US06/07909, PCT International Preliminary Report on Patentability, dated Aug. 16, 2007, 14 pages.
 Patent Cooperation Treaty, PCT/US06/07911, PCT International Preliminary Report on Patentability, dated Feb. 12, 2007, 4 pages.
 Patent Cooperation Treaty, PCT/US06/07911, PCT International Search Report and Written Opinion, dated Jun. 23, 2006, 8 pages.

Erskine, U.S. Appl. No. 11/817,891, Office Communication dated Jun. 11, 2010, 11 pages.

Erskine, Canadian Application No. 2,599,943, Office Action dated Dec. 30, 2010, 2 pages.

Erskine, Canadian Application No. 2,599,945, Notice of Allowance dated Nov. 25, 2010, 1 pages.

Erskine, Canadian Application No. 2,599,955, Office Action dated Dec. 21, 2010, 3 pages.

Erskine, Canadian Application No. 2,599,938, Office Action dated Dec. 20, 2010, 2 pages.

Erskine, Japanese Application No. P2008-500805, Final Office Action dated Jan. 25, 2011, 25 pages.

Erskine, Japanese Application No. P2008-500804, Notice to Grant dated Feb. 2, 2011, 6 pages.

Erskine, Mexican Application No. MX/a/2007/010944, Office Action dated Mar. 11, 2011, 4 pages.

Erskine, Japanese Application No. JP07-5616-XY, Decision to Grant a Patent, dated Apr. 5, 2011, 6 pages.

Erskine, Taiwan Application No. 095107585, Office Action, dated Mar. 17, 2011, 3 pages.

Erskine, Mexican Application No. MX/a/2007/010946, Office Action, dated Apr. 2011, 2 pages.

Erskine, Japan Application No. P2008-500802, Notice of Reasons for Rejection, dated Apr. 5, 2011, 4 pages.

Erskine, U.S. Appl. No. 11/817,892, Office Action, dated Apr. 28, 2011, 25 pages.

Erskine, China Application No. 201010109122.6, Office Action, dated Apr. 1, 2011, 11 pages.

* cited by examiner

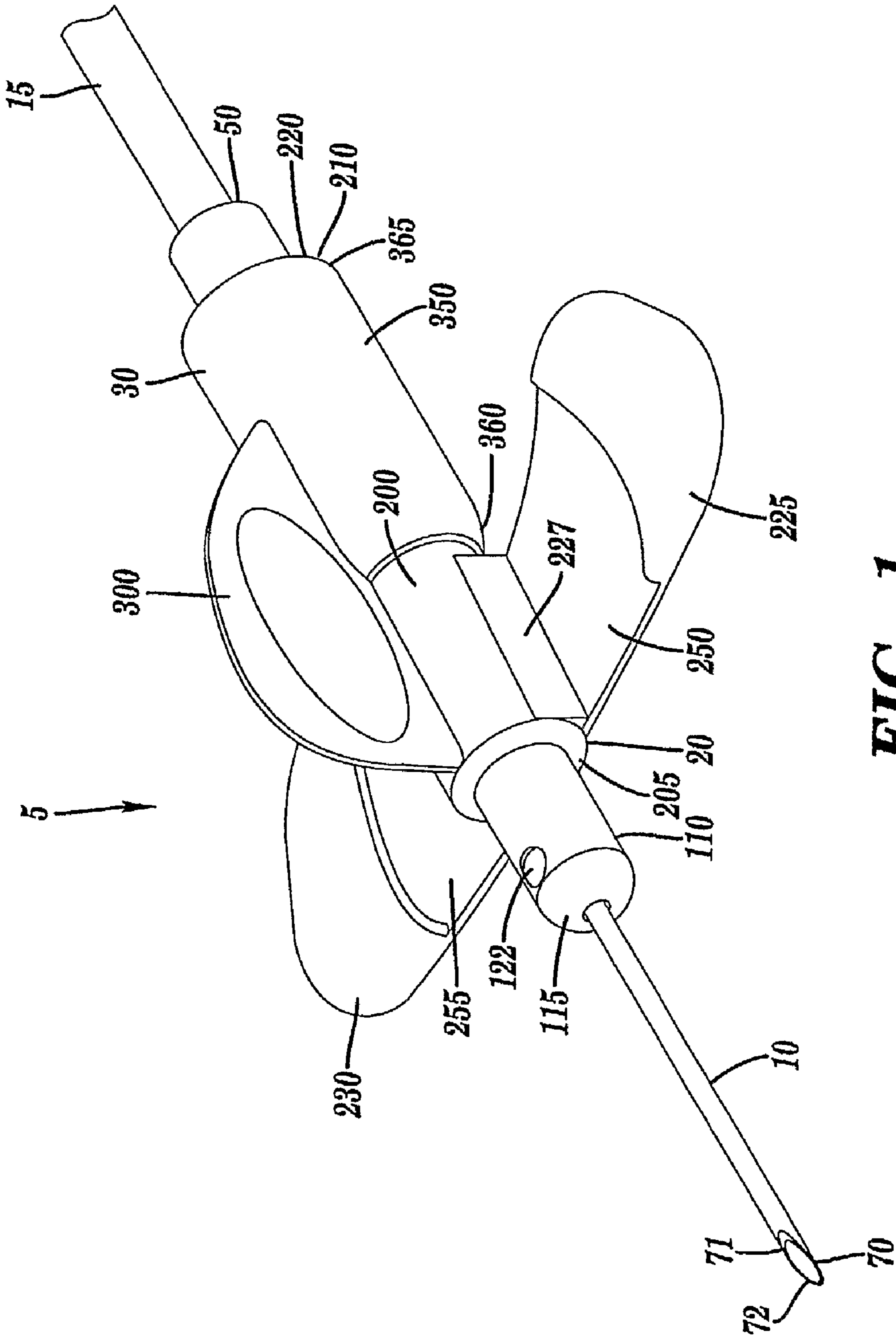

FIG. 1

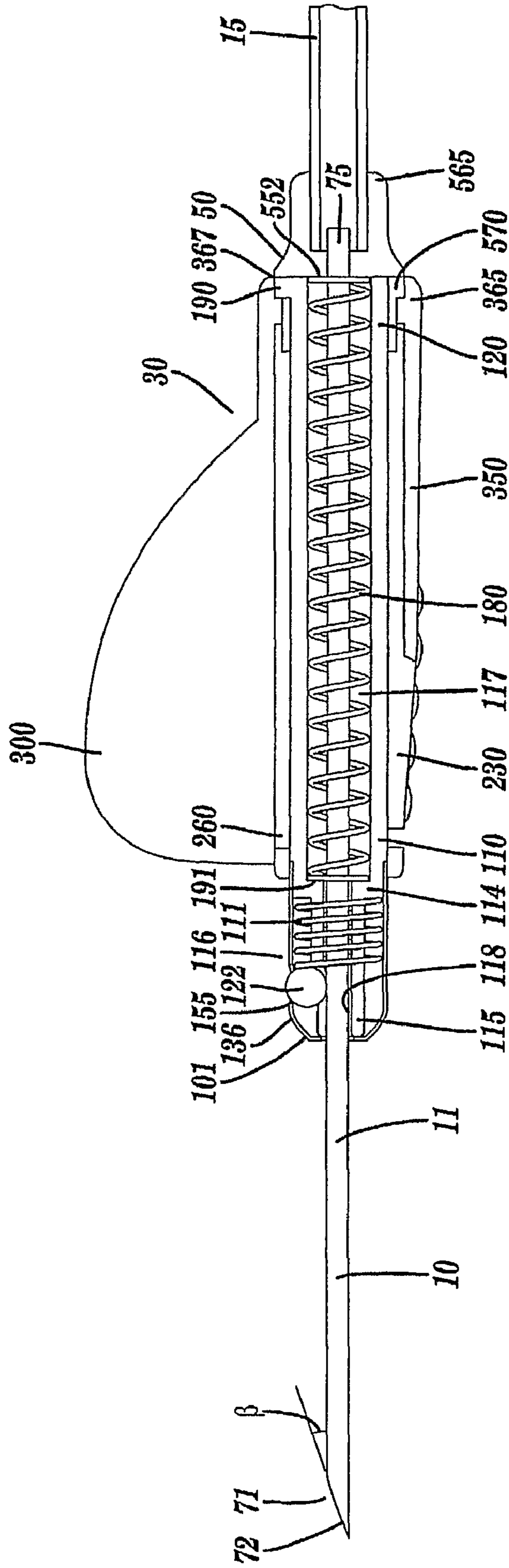
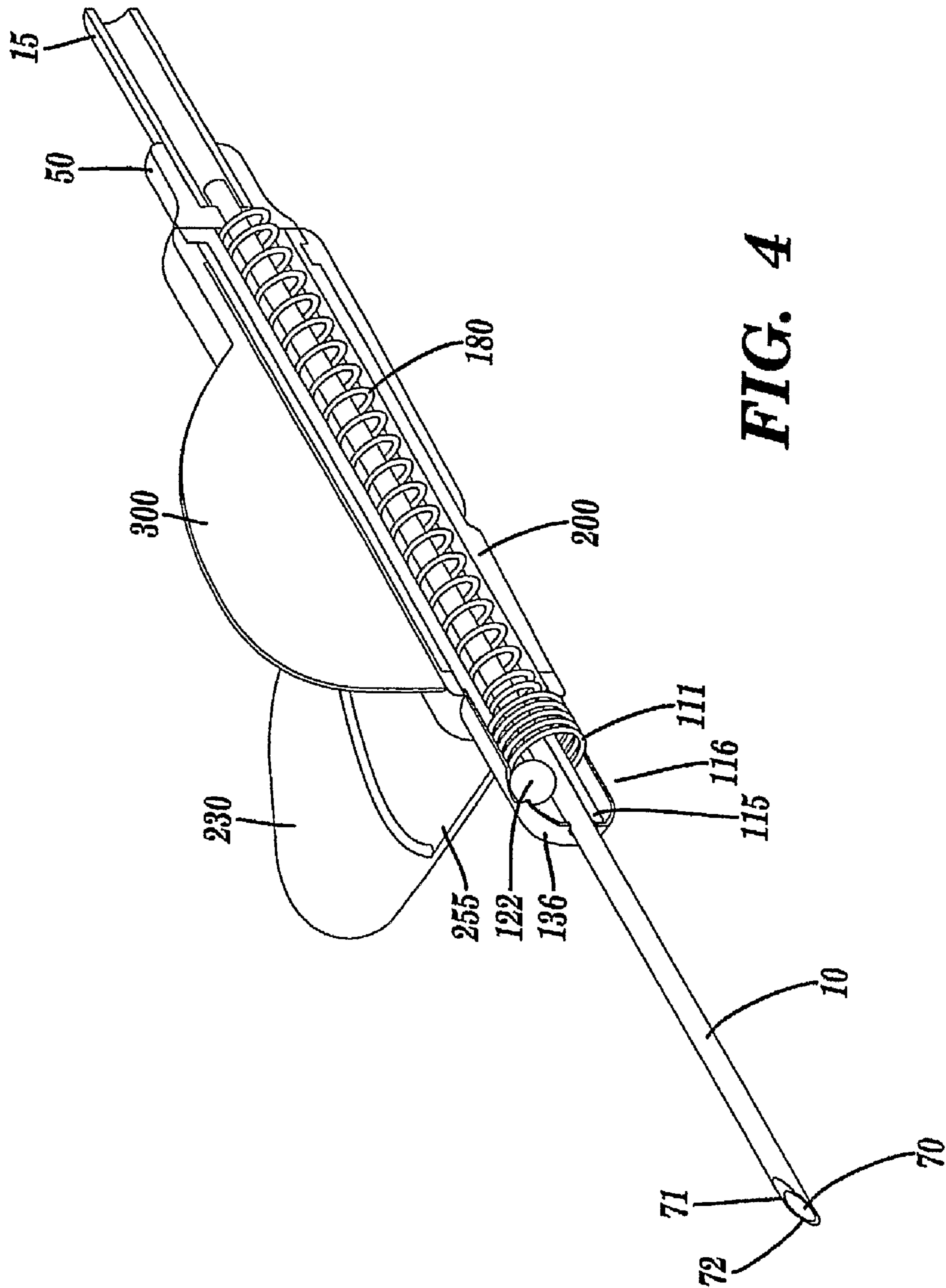

FIG. 3



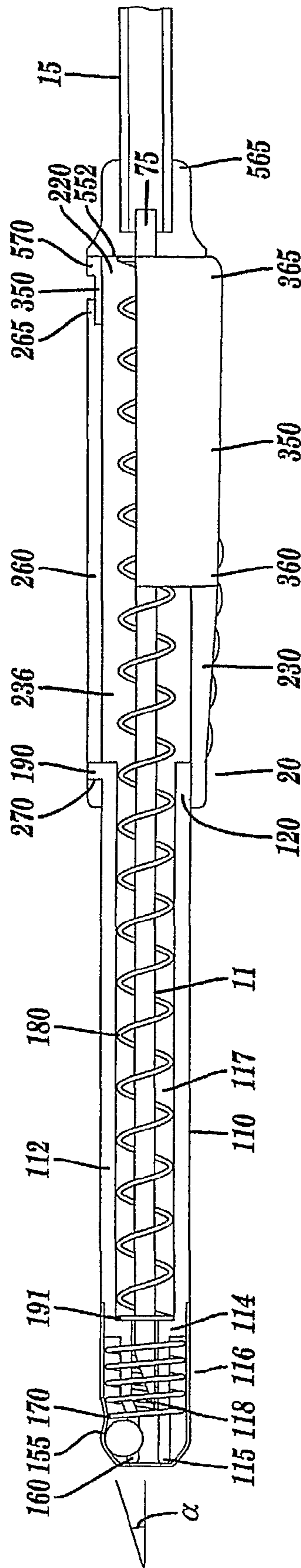

FIG. 5

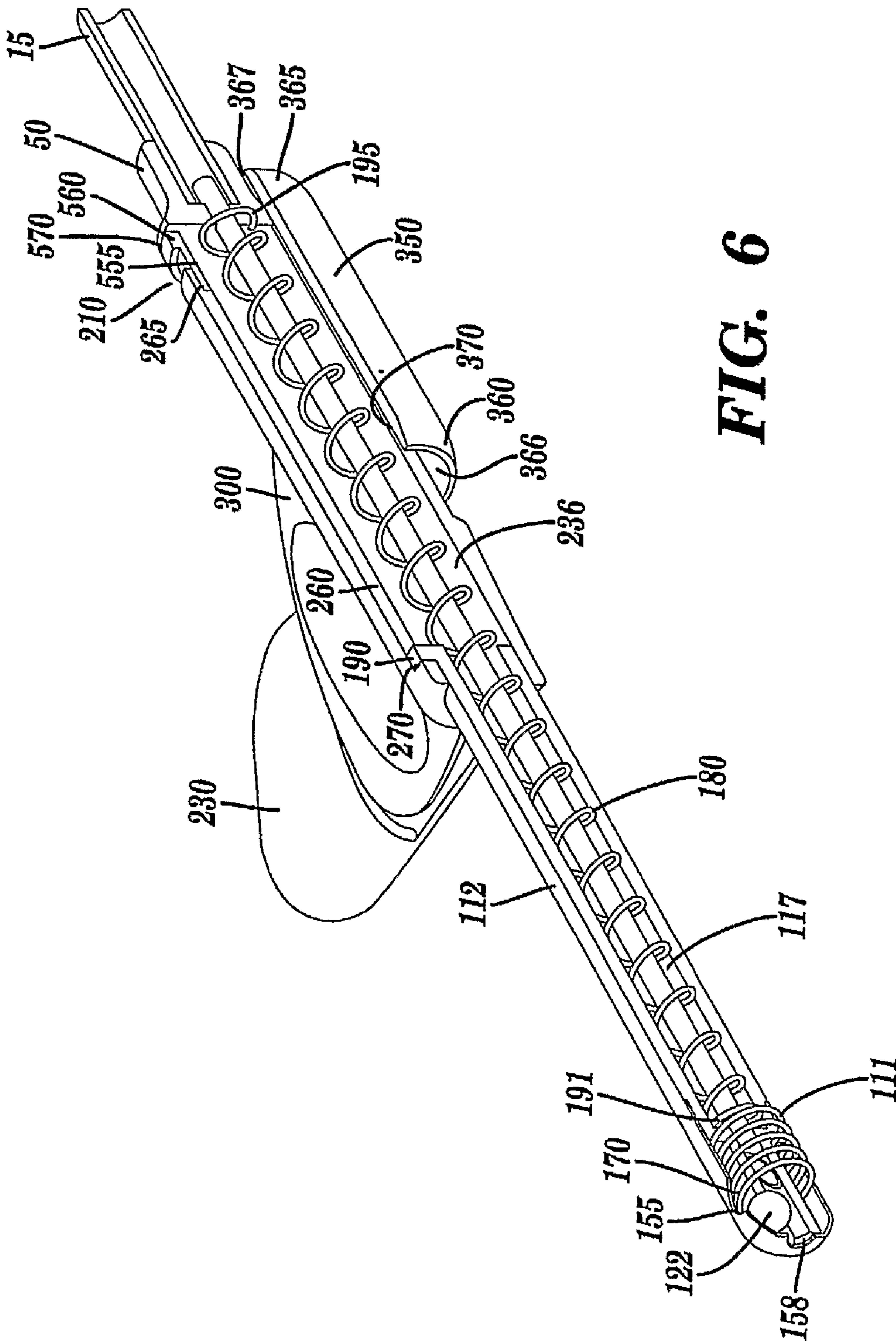

FIG. 6

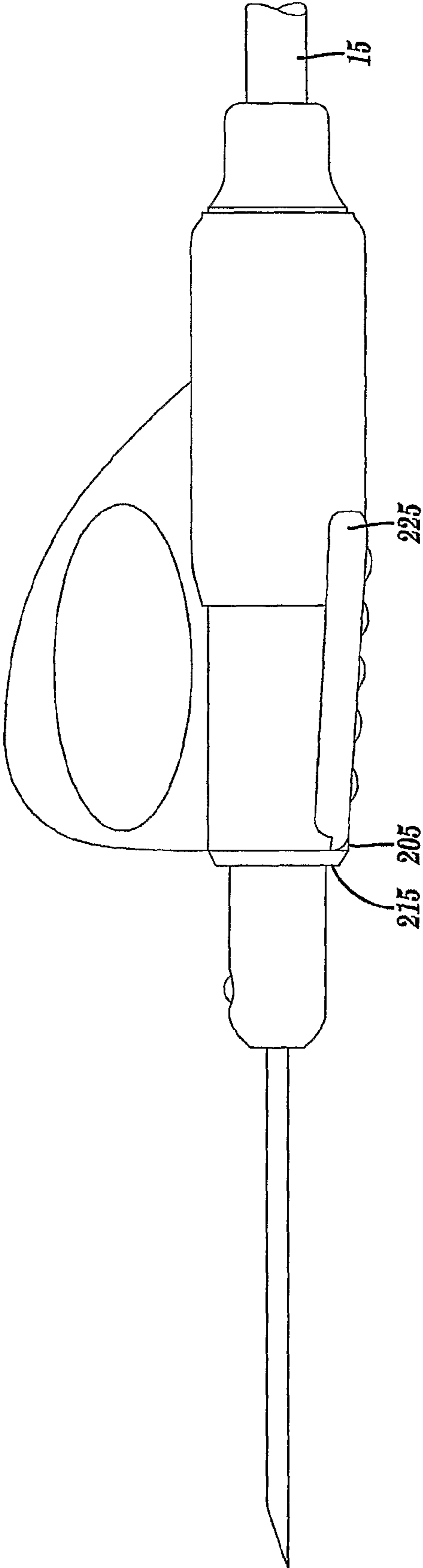

FIG. 7

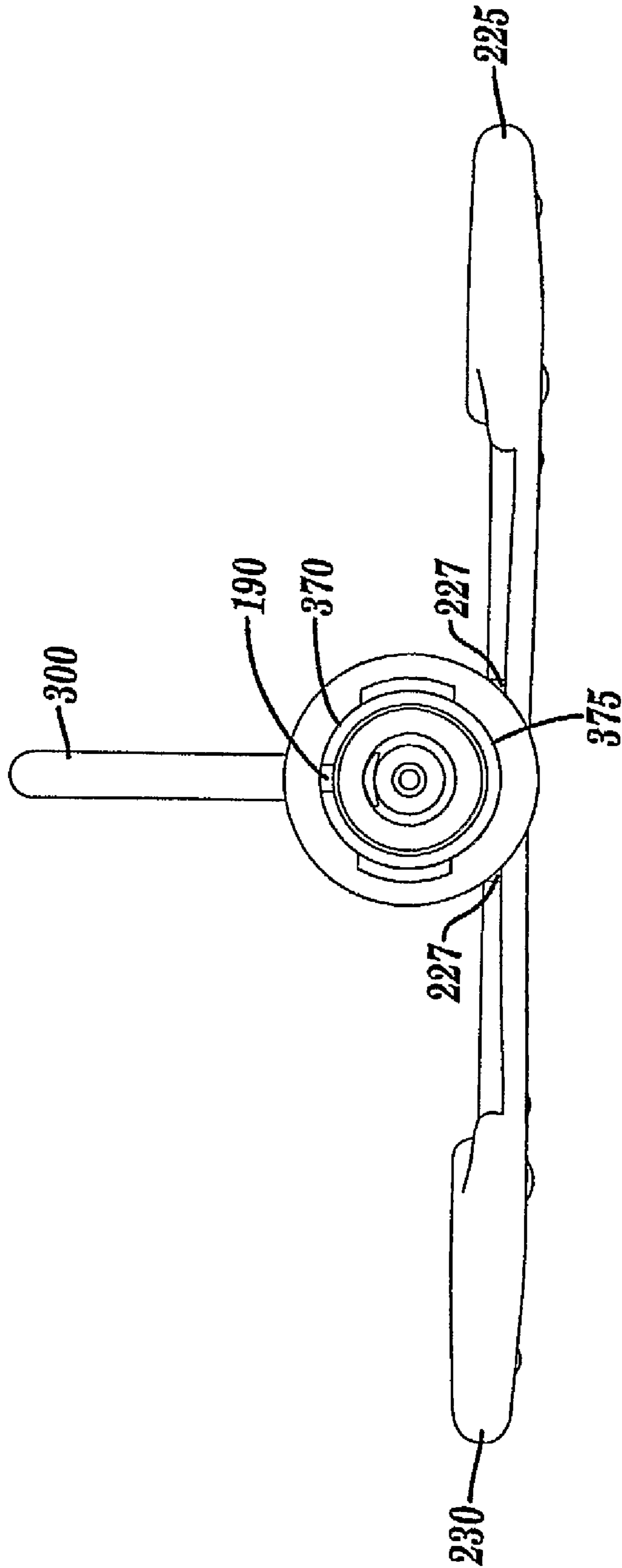

FIG. 8

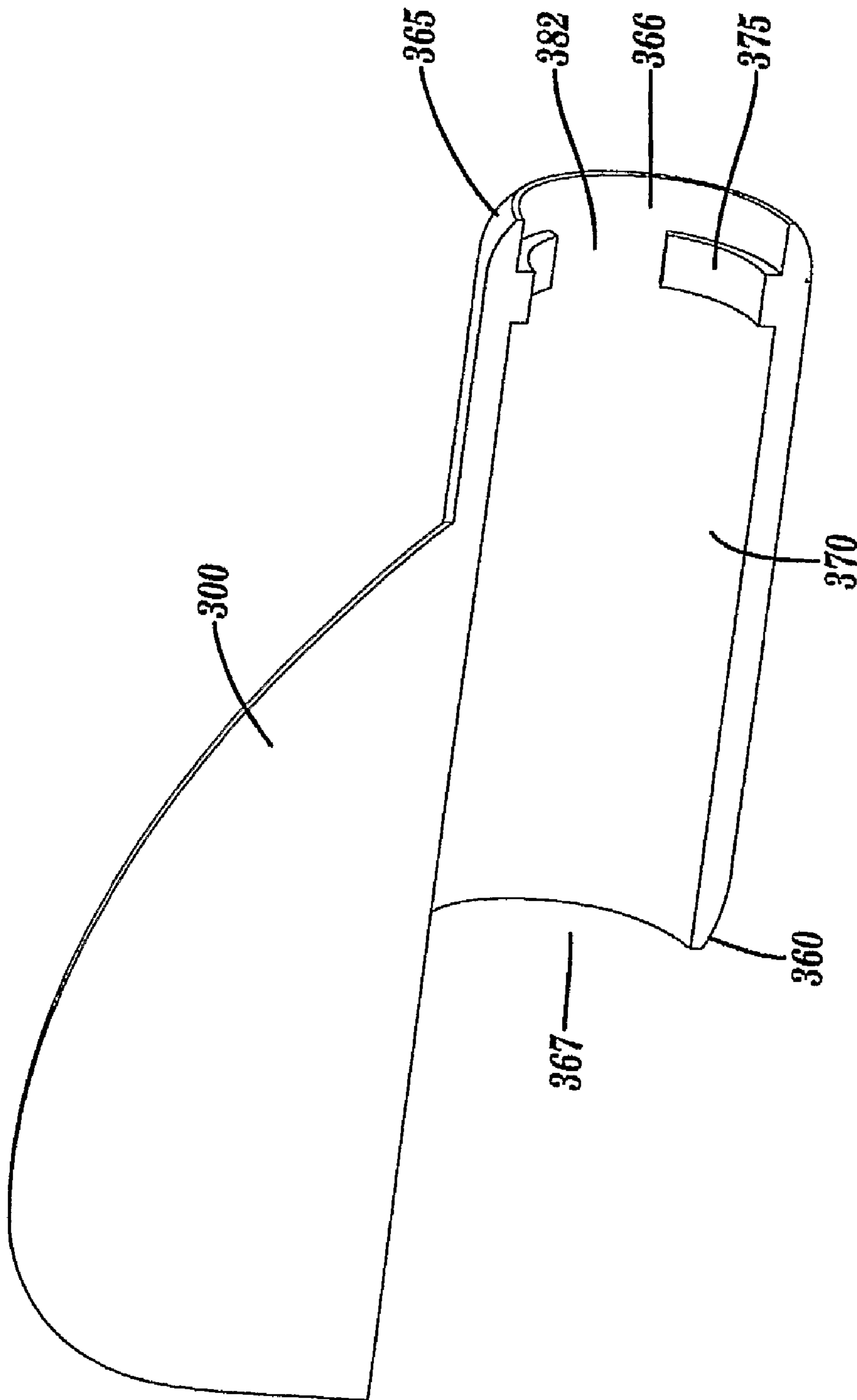

FIG. 9

WINGED NEEDLE WITH NEEDLE SHIELD**CROSS-REFERENCE TO RELATED APPLICATIONS**

This patent application claims priority from, and expressly incorporates by reference, the following provisional patent applications:

- 60/659,226—Shielding Apparatus for Locking onto a Needle—filed on Mar. 7, 2005;
- 60/659,217—Needle Shielding Apparatus with Tubular Needle Cover—filed on Mar. 7, 2005;
- 60/659,213—Needle Shielding Apparatus with Tether to Needle Hub—filed on Mar. 7, 2005;
- 60/714,954—Blood Collection Device with Needle Shield—filed on Sep. 7, 2005.

BACKGROUND

This patent application describes and relates to medical devices for collecting blood or other bodily fluids or infusing fluids, such devices using needles to pierce a human or animal body. It includes a device for shielding such needles.

SUMMARY OF THE INVENTION

An embodiment of the invention is a winged needle set which has a housing with at least one outwardly extending wing (preferably two). A finned member is secured to the housing. The finned member is oriented generally radially outward relative to the longitudinal axis of the needle and is rotatable relative to the housing from a first non-shielding position to a second shielding position. A needle shield assembly is mounted relative to the housing such that the needle shield assembly is slidable longitudinally along the needle. When the finned member is rotated from the first non-shielding position to the second shielding position, the needle shield assembly is unlocked by a release mechanism and permitted to slide relative to the housing along the needle shaft, shielding the needle. In the first non-shielding position, the finned member is oriented from approximately vertical to approximately 60 degrees from vertical. The wing is moveable and can be brought towards the finned member (or rotated or folded) when the finned member is in the first non-shielding position. A spring biases the needle shield assembly to the second shielding position. The wings may be rotatable relative to the housing such that the wings can be brought towards the finned member when the finned member is in the first non-shielding position.

BRIEF DESCRIPTION OF THE DRAWINGS

FIG. 1 is an isometric view of a device incorporating the invention before deployment of the needle shield;

FIG. 2 is an isometric view of a device incorporating the invention after deployment of the needle shield;

FIG. 3 is a cross-sectional side view of a device incorporating the invention before deployment of the needle shield;

FIG. 4 is a cross-sectional isometric view of a device incorporating the invention before deployment of the needle shield;

FIG. 5 is a cross-sectional side view of a device incorporating the invention after deployment of the needle shield;

FIG. 6 is a cross-sectional isometric view of a device incorporating the invention after deployment of the needle shield;

FIG. 7 is a side view of a device incorporating the invention before deployment of the needle shield;

FIG. 8 is a cross sectional view through section A-A in FIG. 7.

FIG. 9 is an isometric view of part of the needle shield actuator of a device incorporating the invention;

FIG. 10 is an isometric view of the distal end of part of a needle shield used in a device incorporating the invention.

DETAILED DESCRIPTION

The following is a description of the preferred embodiment of the invention as applied to a blood collection device. A similar structure may be used for infusing fluids. The purpose of the blood collection device **5** is to pierce a blood vessel (or other organ) using needle **10** and remove blood (or other fluid) to a receptacle via tube **15**. This device makes use of technology described in U.S. Provisional Patent Application No's 60/659,213, 60/659,217 and 60/659,226 which are incorporated herein by reference.

The preferred embodiment of the device is made up of the following basic components:

Housing **20**, with wings **225** and **230**.

Needle **10**, secured to needle hub **50** and in fluid communication with tube **15**.

Needle shield assembly **110**.

Actuator assembly **30**, with rotatable fin **300**.

Housing **20** has a generally cylindrical body **200**, having distal end **205** and proximal end **210**. Distal end **205** has an opening **215**. Proximal end **210** has an opening **220**. A passageway **236** extends between the openings in the proximal and distal ends. Passageway **236** is dimensioned such that shield assembly **110** fits axially in it, and such that shield assembly **110** can slide axially along it. Housing **20** is provided with wings **225** and **230**, which can bend upwards towards each other and towards fin **300** on actuator assembly **30**. Fillet **227** facilitates molding of wings **225** and **230** and housing **20**. An identical fillet is provided to stabilize wing **230**. Wings **225** and **230** are provided with indentations **250** and **255** respectively. These are shaped and dimensioned to accommodate fin **300**. Housing body **200** is provided with a slot **260**, designed to accommodate key **190** on shield assembly **110** (described below). Slot **260** extends from proximal end **210** (where it is open) towards distal end **205** of housing body **200**, where it is closed. Slot **260** has a proximal end **265** and a distal end **270**.

Needle hub **50** has a stepped distal end **550** forming a hollow open ended cylinder **555** which mates with opening **215** in proximal end **210** of housing body **200**. The step forms a flange **570**. Stepped proximal end **550** is provided with a slot **560** (see FIG. 6), which aligns with slot **260** and extends from flange **570**, along cylinder **555** to its open end. Slot **560** also accommodates key **190**. Slot **560** is open at the front to allow key **190** to move in it and closed at the back to prevent key **190** from leaving it.

Proximal end **75** of needle **10** is glued into needle hub **50**. Rear end **565** is an open ended cylinder extending proximally which is designed to mate with tube **15**, thus permitting fluid to flow through needle **10** and tube **15** and into a receptacle for collection.

Fin assembly **30** has a cylindrical body section **350** having a proximal end **365** and a distal end **360**. Proximal and distal ends **365**, **360** are respectively provided with openings **366** and **367**. A passage **370** extends between the proximal and distal ends. Passage **370** has an inner surface **372**. Fin assembly **30** fits concentrically over cylindrical body **200** and can rotate about the axis of cylindrical body **200**, constrained by wings **225** and **230**. Near proximal end **365**, inner surface **372** is provided with a circumferential rim **375**. Rim **375** has

sections removed from it forming openings **380** and **382** (only **382** is shown in FIG. 9, **380** being substantially identical to **382**), dimensioned to allow passage of key **190**. These openings start at about +70 degrees and -70 degrees to the vertical and describe arcs of about 30 degrees. When fin assembly **30** is in a first, non-shielding position (see, FIGS. 1, 3, 4, 7, and 8), rim **375** blocks key **190**. In that first position, when key **190** is blocked by rim **375**, fin **300** is vertical. When fin **300** is rotated clockwise or counter-clockwise, cylindrical body section **350** (and hence rim **375**) rotates about the axis of body section **200**. When fin assembly **30** is rotated to a second, shielding position (anywhere from about 60 degrees to the vertical to about 90 degrees to the vertical, clockwise or counter-clockwise, see FIGS. 2, 5, and 6) in which key **190** aligns with opening **380** or **382** (depending on the direction of rotation) key **190** is free to travel distally in slot **260**. When that happens, under the influence of coil spring **180** abutting inner wall **114** of cylindrical body **112**, needle shield assembly **110** will move in the distal direction, thus shielding the needle.

The combination of rim **375** and key **190** thus forms part of a triggering mechanism which allows shield assembly to be unlocked and to move in the distal direction when needle **10** is to be shielded.

When fin **300** has been rotated to a position against either wing **225** or wing **230**, fin **300** may be secured to the skin of the patient. To that end, fin **300** may be provided with an adhesive strip. Needle shield assembly **110** has a cylindrical body **112** having a proximal end **120** and distal end **115**. Lumen **117** extends between proximal end **120** and distal end **115** and is dimensioned to accommodate needle **10** axially such that it can slide over needle **10**. Needle shield assembly **110** fits axially into housing body **200** such that it can slide axially along passageway **236**. Proximal end **120** is provided with key **190**. As described above, key **190** fits into slot **260** and slot **560**. Key **190** prevents shield assembly **110** from rotating relative to housing body **200**. It also prevents shield assembly **110** from exiting opening **220** of housing body **200** in the proximal direction, when it abuts distal end **270** of slot **260**.

At distal end **115** of needle shield assembly **110** there is a stop mechanism **116** for preventing shield assembly from sliding backwards once needle **70** is shielded. Distal end **115** has a stepped section **150**, i.e. a region of reduced diameter in comparison with the remaining cylindrical part of cylindrical body **112**. Lumen **117** also has a reduced diameter in stepped section **150** compared with the diameter of lumen **117**. In this region, lumen **117** is referred to as lumen **118**. The diameter of lumen **118** is only slightly larger than the outer diameter of needle **10**. Coil spring **111** is threaded over stepped section **150**. The rear end of coil spring **111** abuts the wall **114** formed at the intersection of stepped section **150** and the remainder of cylindrical body **112**. Coil spring **111** is a compression spring which exerts its force axially in the proximal and distal directions. Stepped section **150** is also provided with opening **160** in the form of a specially shaped slot extending in a distal direction approximately from the mid point of stepped section **150** to distal end **115** of cylindrical body **112** (see FIG. 10). This opening **160** is dimensioned and shaped such that ball **122** rests in it, with part of ball **122** extending into lumen **118** of cylindrical body **112** and abutting outer surface **11** of needle **10**. The force in coil spring **111** keeps ball **122** pressed against needle **10**. Shield assembly **110** can thus slide along needle **10** with very low frictional force. Opening **160** is also dimensioned and shaped such that when ball **122** no longer abuts needle **10** (i.e. the tip has passed ball **122**), ball **122** can move distally towards distal end of **115** of cylindrical body

112 and radially further into lumen **118**, thus blocking axial movement of needle **10** in the distal direction. This is described in greater detail below.

Cap **100** is a metal stamping, dimensioned to fit over stepped section **150**, thus enclosing coil spring **111**. Cap **100** is provided with opening **170**, dimensioned such that part of ball **122** can fit into it, when needle **10** abuts ball **122**, but such that ball **122** cannot escape through it. Cap **100** may be limited in size to fit over distal end **115** of cylindrical body **110** or it can extend along the entire length of cylindrical body **115** as a unitary sheath.

Behind stepped section **150**, within lumen **117** of cylindrical body **112** lies coil spring **180**. Coil spring **180** is a compression spring whose force is exerted axially in the proximal and distal directions. Distal end **191** of coil spring **180** abuts the back of inner wall **114** just behind stepped section **150**. Proximal end **195** of coil spring **180** abuts proximal face **552** of needle hub **50** (i.e. in the region of flange **570**, but inside cylinder **555**). Coil spring **180** is therefore trapped within cylindrical body **112** of shield assembly **110** and inside housing **20**. When shield assembly **110** is in its un-actuated position, coil spring **180** is compressed.

The operation of stop mechanism **116** will now be described. Needle tip **70** has a beveled tip with two bevels, first bevel **71** and second bevel **72**. When needle shield assembly **110** slides along the length of needle **10** in the distal direction, ball **122** aligns with bevel **71**. When ball **122** encounters bevel **71**, it is less radially constrained by needle **10** and it moves radially towards the axis of needle **10** under the influence of the force in coil spring **111**. Ball **122** thus moves out of opening **170** in cap **100** and radially inwards, further into lumen **118**. Ball **122** pivots about edge **155** in opening **170** and slides distally along the length of opening **160**. When second bevel is aligned with ball **122**, it moves as far as it can in opening **160** and is positioned directly above second bevel **72**. At that point it will have traveled as far into lumen **117** as it can, constrained by the dimensions of opening **160** and by distal end **101** of cap **100**. Spring **111** has expanded and now constrains ball **122** radially. Ball **122** partially occludes lumen **118**, thus blocking the passage of needle tip **70** and preventing shield assembly **110** from being pulled back to expose needle tip **70**.

At this point, key **190** has reached distal end **270** of slot **260**, so further distal movement of shield assembly **110** relative to needle **10** is prevented. The distance from key **190** to needle tip **70** is set so that when tip **70** is aligned with ball **122**, there is sufficient space for ball **122** to move beneath cap **100** in opening **160**. Upper surface **136** of distal end **101** of cap **100** (i.e. the part of the needle shield assembly **110** that is immediately radially outward of ball **122** and which ball **122** abuts when the shield is deployed) forms an angle α tangential to ball **122** when ball **122** is moving into its position at least partially occluding lumen **118**. This can be seen in FIG. 5. This angle α is set at a value less than the smallest bevel angle β of needle tip **70** (bevel **72** in this case). In the described embodiment, the angle α between the upper surface **136** of distal end **101** and ball **122** is about zero degrees. If that angle is made too large relative to angle β , ball **122** will not be trapped. Distal end **158** of stepped area **155** and cap **100** are dimensioned to overhang so that tip **70** can never emerge from shield assembly **110**. It is possible to employ multiple balls sitting in multiple openings the same as opening **160** and **170**. If this is done, the overhang can be reduced.

After deployment, but before needle **10** moves distally, part of ball **122** lies in lumen **118** and part of it is urged against the inside of distal end **101** of cap **100** by spring **111**. The top of ball **122** lies beneath upper surface **136** of distal end **101** of

5

cap 100. In an alternative embodiment, spring 111, having expanded, closes off the opening 170. If needle 10 moves distally, it will abut ball 122, which will be forced against the inside of end 101 of cap 100. Further distal movement of needle 10 and hence emergence of needle tip 70 from shield assembly 110 will be prevented.

Lumen 118 is sized such that needle 10 fits in it snugly. Thus when needle 10 is moved distally (i.e. shield assembly 110 is moved proximally) and ball 122 abuts needle tip 70, needle 10 will not move away from ball 122. Lumen 170 thus provides support opposite ball 122 to prevent needle 10 from wiggling, and to prevent tip 70 from moving such that it pierces the wall of lumen 118.

In an alternative embodiment, ball 122 fully enters lumen 118. Ball 122 thus has a diameter slightly larger than that of lumen 118. Ball 122 is then axially constrained by lumen 118 and needle 10. In this case, lumen 118 is also dimensioned to provide support for needle 10 opposite ball 122, thus preventing wiggle of the needle and preventing tip 70 from piercing the wall of lumen 118.

Ball 122 moves a distance at least equal to the amount by which it protrudes from opening 155 in cap 100. When the shield is deployed, ball 122 extends into lumen 118 by an amount approximately equal to that distance. This leaves part of lumen 118 un-occluded. If a small gauge needle is used a larger ball is needed in order to occlude lumen 118 sufficiently to prevent tip 70 from poking through the un-occluded part of lumen 118 and so that ball 122 will extend from the surface of needle 10 into opening 160. The same effect can be obtained by making cap 100 smaller and using the same sized ball. If a large gauge needle is used (i.e. a needle having large diameter), the ball can be smaller.

Device 5 is assembled in the following way:

1. Needle shield assembly 110 is dropped into housing 20 from proximal end 210 of housing 20. Key 190 is aligned with slot 260 of housing 20.

2. Finned member 30 is slid over housing 20, from proximal end 210 of housing 20. During this step, fin 300 is at about 60-90 degrees to the vertical, thus aligning opening 380 or opening 382 with key 190. Finned member 30 is then rotated to the vertical position, locking key 190 behind rim 375.

3. Spring 180 is placed inside lumen 117 of shield assembly 110, also from proximal end 210 of housing 20. Distal end 190 of spring 180 abuts the back of wall 114 of needle shield.

4. Needle hub 50 is snapped or glued onto proximal end 210 of housing 20, compressing spring 180. Slot 570 in cylindrical wall of hub 50 is aligned with slot 260 on housing 20.

5. Needle 10 is threaded into hole 113 of needle shield assembly 110, through lumens 118, 117 and spring 180 and glued into needle hub 55.

6. Tube 15 is glued into proximal end 555 of needle hub 55.

The device is used in the following way:

The user grasps wings 225 and 230 between his or her fingertips and brings them together so that they touch fin 300. Alternatively, the device can be held simply by grasping fin 300 between the finger tips. Finger grips are provided in fin 300 for that purpose. Holding the device in either of those two ways, with fin 300 in the vertical (first) position, the user pierces the patient's skin and blood vessel with needle tip 70. Once the blood vessel has been pierced and blood can flow through needle 10, the user rotates fin 300 down towards either wing 225 or 230, thus unblocking key 190 (the second position). Needle shield assembly 110 is thus free to slide axially over the needle in the distal direction, urged by spring 180. Fin 300 is placed in cutout 250 or 255, so it is flush with the relevant wing. Wings 225 and 230 and fin 300 can be taped to the patient's skin while the blood is collected.

6

In this blood collection (second) position, needle shield assembly 110 has slid axially in the distal direction due to the force of spring 180. Distal end 115 of needle shield assembly lies against the patient's skin. As needle tip 70 is withdrawn, distal end 115 of needle shield assembly, still under the influence of spring 180, moves in the distal direction until, as tip 70 is removed from the patient, it is completely shielded.

The shielding mechanism at the tip of the needle prevents needle shield assembly 110 from sliding in the proximal direction and re-exposing needle tip 70. Key 190 abuts distal end 270 of slot 260, thus preventing distal movement of needle shield assembly 110. Needle 10 is thus completely shielded. Even if fin 300 is rotated back into the first position (to facilitate removal of needle 10 from the patient), shield assembly 110 cannot be retracted because it is blocked from proximal movement by ball 122. Key 190 has moved distally with respect to circumferential rim 375.

Although limited embodiments of the winged needle assemblies, their components, and their applications on different needle devices have been specifically described and illustrated, the descriptions are not intended to limit the scope of the basic invention. Many modifications and variations will be apparent to those skilled in the art. Accordingly, it is to be understood that the winged needle assemblies and their components constructed according to principles of this invention may be embodied other than as specifically described herein. The invention is also defined in the following claims.

I claim:

1. A medical needle assembly comprising:

a needle comprising a longitudinal axis, a proximal end, a sharp distal end and an outer surface;

a housing with a pair of radially outwardly extending wings lying opposite one another defining a plane;

an actuator member concentrically mounted on the housing, and extending substantially radially outwardly from the housing and substantially perpendicular to the longitudinal axis of the needle,

wherein the actuator member is freely circumferentially rotatable relative to the housing, the pair of radially outwardly extending wings, and the longitudinal axis of the needle between the pair of radially outwardly extending wings, from a first, non-shielding perpendicular to the plane position to a second, shielding position substantially parallel to the plane,

wherein the actuator member remains substantially perpendicular to the longitudinal axis of the needle;

a needle shield assembly mounted relative to the housing, such that the needle shield assembly is slidable longitudinally along the needle relative to the housing, the pair of radially outwardly extending wings, and the actuator member; and

a release mechanism associated with the actuator member and the needle shield assembly such that when the actuator member is circumferentially rotated relative to the housing, the pair of radially outwardly extending wings, and the longitudinal axis of the needle, from the first, non-shielding position to the second, shielding position, the needle shield assembly is unlocked and permitted to slide relative to the housing, the pair of radially outwardly extending wings, and the longitudinal axis of the needle, along the needle shaft, thereby shielding the needle.

2. The needle assembly of claim 1, wherein, in the first non-shielding position, the actuator member has an orientation from approximately vertical to approximately 60 degrees from vertical.

7

3. The needle assembly of claim 1, wherein the pair of wings are circumferentially moveable relative to the longitudinal axis of the needle such that each of the pair of wings can be brought towards the actuator member when the actuator member is in the first non-shielding position.

4. The needle assembly of claim 3, wherein the wings can be rotated towards the actuator member.

5. The needle assembly of claim 3, wherein the wings can be folded towards the actuator member.

6. The needle assembly of claim 1, further comprising a spring biasing the needle shield assembly to the second, shielding position, such that when the actuator member is rotated to the second, shielding position, the needle shield moves over the needle.

7. The needle assembly of claim 1, wherein the wings are rotatable relative to the housing such that the wings can be brought towards the actuator member when the actuator member is in the first, non-shielding position.

8. The needle assembly of claim 1, wherein the release mechanism further comprises:

a key provided on a proximal end of the needle shield assembly; and

a slot provided in the housing, wherein the slot is shaped and dimensioned to accommodate the key,

wherein in the first, non-shielding position, the actuator member is oriented vertically relative to the pair of radially outwardly extending wings, and the key is blocked by a portion of the actuator member; and

wherein in the second, shielding position, the actuator member is circumferentially rotated relative to the housing, the pair of radially outwardly extending wings, and the longitudinal axis of the needle such that it is positioned between about 60 degrees from vertical and about 90 degrees from vertical, and the key aligns with the slot.

9. The needle assembly of claim 8, wherein the portion of the actuator member further comprises a rim located on a proximal end of the actuator member, wherein the rim includes at least one opening;

wherein in the second, shielding position, the at least one opening is aligned with the slot and the key, and the key is free to travel in a distal direction in the slot.

10. The needle assembly of claim 9, further comprising a spring biasing the needle shield assembly in the distal direction, such that when the actuator member is rotated to the second, shielding position, the key travels in a distal direction in the slot, and the needle shield moves over the needle.

11. The needle assembly of claim 1, wherein the actuator member further comprises a fin, and wherein the fin includes an adhesive for securing the fin to a skin surface of a patient when the actuator member is in the second, shielding position.

12. A medical needle assembly comprising:

a needle comprising a longitudinal axis, a proximal end, a sharp distal end and an outer surface;

a housing with a pair of wings extending radially outwardly opposite each other to define a plane;

an actuator member concentrically mounted on the housing, and extending substantially radially outwardly from

8

the housing and substantially perpendicular to the longitudinal axis of the needle,

wherein the actuator member is freely circumferentially rotatable relative to the housing, the pair of wings, and the longitudinal axis of the needle, from a first, non-shielding position perpendicular to the plane to a second, shielding position, and

wherein the actuator member remains substantially perpendicular to the longitudinal axis of the needle;

a needle shield assembly mounted relative to the housing, such that the needle shield assembly is slidable longitudinally along the needle relative to the housing, the pair of wings, and the actuator member, the needle shield assembly comprising a unitary sheath; and

a release mechanism associated with the actuator member and the needle shield assembly such that when the actuator member is circumferentially rotated relative to the housing, the pair of wings, and the longitudinal axis of the needle, from the first, non-shielding position to the second, shielding position substantially parallel to the plane, the needle shield assembly is unlocked and permitted to slide relative to the housing, the pair of wings, and the actuator member along the needle shaft, thereby shielding the needle.

13. The needle assembly of claim 12, wherein the release mechanism further comprises:

a key provided on a proximal end of the needle shield assembly; and

a slot provided in the housing, wherein the slot is shaped and dimensioned to accommodate the key,

wherein in the first, non-shielding position, the actuator member is oriented vertically relative to the pair of radially outwardly extending wings, and the key is blocked by a portion of the actuator member; and

wherein in the second, shielding position, the actuator member is circumferentially rotated relative to the housing, the pair of radially outwardly extending wings, and the longitudinal axis of the needle such that it is positioned between about 60 degrees from vertical and about 90 degrees from vertical, and the key aligns with the slot.

14. The needle assembly of claim 13, wherein the portion of the actuator member further comprises a rim located on a proximal end of the actuator member, wherein the rim includes at least one opening;

wherein in the second, shielding position, the at least one opening is aligned with the slot and the key, and the key is free to travel in a distal direction in the slot.

15. The needle assembly of claim 14, further comprising a spring biasing the needle shield assembly in the distal direction, such that when the actuator member is rotated to the second, shielding position, the key travels in a distal direction in the slot, and the needle shield moves over the needle.

16. The needle assembly of claim 12, wherein the actuator member further comprises a fin, and wherein the fin includes an adhesive for securing the fin to a skin surface of a patient when the actuator member is in the second, shielding position.

* * * * *