



US007985727B1

(12) **United States Patent**
Murase et al.(10) **Patent No.:** **US 7,985,727 B1**
(45) **Date of Patent:** ***Jul. 26, 2011**(54) **APO A-I MIMETIC PEPTIDES AND METHODS OF TREATMENT**(75) Inventors: **Katsuyuki Murase**, Cupertino, CA (US); **Li Zhao**, Mountain View, CA (US); **Irina Astafieva**, Palo Alto, CA (US); **Paul M. Consigny**, San Jose, CA (US)(73) Assignee: **Abbott Cardiovascular Systems Inc.**, Santa Clara, CA (US)

(*) Notice: Subject to any disclaimer, the term of this patent is extended or adjusted under 35 U.S.C. 154(b) by 170 days.

This patent is subject to a terminal disclaimer.

(21) Appl. No.: **11/858,851**(22) Filed: **Sep. 20, 2007**(51) **Int. Cl.****A61K 38/10** (2006.01)**A61K 31/661** (2006.01)(52) **U.S. Cl.** **514/2; 514/12; 514/13; 530/300; 424/9.1**(58) **Field of Classification Search** **514/2, 12, 514/13; 530/300; 424/9.1**

See application file for complete search history.

(56) **References Cited****U.S. PATENT DOCUMENTS**

| | | | |
|--------------|----|---------|------------------|
| 4,643,988 | A | 2/1987 | Segrest et al. |
| 4,925,677 | A | 5/1990 | Feijen |
| 5,202,745 | A | 4/1993 | Sorin et al. |
| 5,291,267 | A | 3/1994 | Sorin et al. |
| 5,321,501 | A | 6/1994 | Swanson et al. |
| 5,365,125 | A | 11/1994 | Goetting et al. |
| 5,459,570 | A | 10/1995 | Swanson et al. |
| 5,465,147 | A | 11/1995 | Swanson |
| 5,700,484 | A | 12/1997 | Chauffard et al. |
| 5,783,600 | A | 7/1998 | Bisgaier et al. |
| 5,874,075 | A | 2/1999 | Collins et al. |
| 6,124,273 | A | 9/2000 | Drohan et al. |
| 6,376,464 | B1 | 4/2002 | Dasseux et al. |
| 6,506,799 | B1 | 1/2003 | Dasseux |
| 6,602,854 | B1 | 8/2003 | Dasseux et al. |
| 6,692,466 | B1 | 2/2004 | Chow et al. |
| 6,753,313 | B1 | 6/2004 | Dasseux et al. |
| 6,831,105 | B2 | 12/2004 | Dasseux |
| 6,844,327 | B2 | 1/2005 | Dasseux et al. |
| 6,852,760 | B1 | 2/2005 | Fine et al. |
| 6,878,817 | B2 | 4/2005 | Lees et al. |
| 6,881,860 | B2 | 4/2005 | Luchoomun et al. |
| 6,900,177 | B1 | 5/2005 | Dasseux et al. |
| 6,960,648 | B2 | 11/2005 | Bonny |
| 7,273,469 | B1 | 9/2007 | Chan et al. |
| 2004/0229794 | A1 | 11/2004 | Ryan et al. |
| 2004/0254120 | A1 | 12/2004 | Fogelman et al. |
| 2004/0266671 | A1 | 12/2004 | Fogelman et al. |
| 2005/0118226 | A1 | 6/2005 | Kovacs et al. |
| 2005/0175666 | A1 | 8/2005 | Ding |
| 2005/0176623 | A1 | 8/2005 | Wagle |
| 2005/0202532 | A1 | 9/2005 | Bielicki et al. |
| 2005/0222029 | A1 | 10/2005 | Bartel et al. |
| 2005/0232981 | A1 | 10/2005 | Ben-Sasson |
| 2009/0081293 | A1 | 3/2009 | Murase et al. |
| 2009/0081299 | A1 | 3/2009 | Hossainy et al. |

FOREIGN PATENT DOCUMENTS

| | | |
|----|------------------|---------|
| WO | WO-9736927 | 10/1997 |
| WO | WO-9916408 | 4/1999 |
| WO | WO-03026492 A2 | 4/2003 |
| WO | WO-03096983 | 11/2003 |
| WO | WO-2005041866 A2 | 5/2005 |
| WO | WO-2006047279 | 5/2006 |
| WO | WO-2006100567 | 9/2006 |
| WO | WO-2006100567 A1 | 9/2006 |
| WO | WO-2008048387 | 4/2008 |
| WO | WO-2008048387 A2 | 4/2008 |

OTHER PUBLICATIONS

"Arisaph Reports on Promising Results Presented at AHA: Novel APO A-I Mimetic Peptide Significantly Inhibits Atherosclerosis in Preclinical Animal Study", News Release, Arisaph Pharmaceuticals, Boston, MA, (Nov. 15, 2005), 2 pages.

Aragane, K., et al., "ACAT inhibitor F-1394 prevents intimal hyperplasia induced by balloon injury in rabbits", *Journal of Lipid Research*, 42, (2001), 480-488.Batetta, B., et al., "Role of cholesterol ester pathway in the control of cell cycle in human aortic smooth muscle cells", *FASEB Journal*, 17, (2003), 746-748.Chang, T. Y., et al., "Catalysis of ACAT may be completed within the plane of membrane: a working hypothesis", *Journal of Lipid Research*, 42, (2001), 1933-1938.Datta, G., et al., "Aromatic residue position on the nonpolar face of class A amphipathic helical peptides determines biological activity", *Journal of Biological Chemistry*, 279(24), (2004), 26509-26517.Gupta, H., et al., "Inhibition of lipopolysaccharide-induced inflammatory responses by an apolipoprotein AI mimetic peptide", *Circulation Research*, 97, (2005), 236-243.Hartgerink, J. D., et al., "Peptide-amphiphile nanofibers: a versatile scaffold for the preparation of self-assembling materials", *PNAS*, 99(8), (Apr. 2002), 5133-5138.Hartgerink, J. D., et al., "Self-assembly and mineralization and peptide-amphiphile nanofibers", *Science*, www.sciencemag.org, 294, (Nov. 2001), 1684-1688.

(Continued)

Primary Examiner — Chih-Min Kam(74) *Attorney, Agent, or Firm* — Blakely Sokoloff Taylor & Zafman LLP(57) **ABSTRACT**

A method including advancing a delivery device through a lumen of a blood vessel to a particular region in the blood vessel; and introducing a synthetic apolipoprotein A-1 (Apo A-I) mimetic peptide into a wall of the blood vessel at the particular region, wherein the peptide has a property that renders the peptide effective in reverse cholesterol transport. A composition including a synthetic apolipoprotein A-I (Apo A-I) mimetic peptide, or combination of an Apo A-I synthetic peptide and an Acyl CoA cholesterol: acyltransferase (ACAT) inhibitor in a form suitable for delivery into a blood vessel, the peptide including an amino acid sequence in an order reverse to an order of an endogenous Apo A-I related peptide. A composition including an apolipoprotein A-1 (Apo A-I) synthetic peptide in a form suitable for delivery into a blood vessel, the peptide including an amino acid backbone that has less amino acid residues relative to endogenous Apo A-I and a chimera of helix 1 and helix 9 of Apo A-I.

8 Claims, 8 Drawing Sheets

OTHER PUBLICATIONS

- Li, X., et al., "Differential effects of apolipoprotein A-I-mimetic peptide on evolving and established atherosclerosis in apolipoprotein e-null mice", *Circulation, Journal of the American Heart Association*, 110, (2004), 1701-1705.
- Linsel-Nitschke, P., et al., "HDL as a target in the treatment of atherosclerotic cardiovascular disease", *Nature Reviews Drug Discovery*, 4(10), Abstract, (2005), 193-205.
- Natarajan, P., et al., "Identification of an apolipoprotein A-I structural element that mediates cellular cholesterol efflux and stabilizes ATP binding cassette transporter A1", *Journal of Biological Chemistry (JBC)*, 279(23), (2004), 24044-24052.
- Navab, M., et al., "Human apolipoprotein A-I and A-I mimetic peptides: potential for atherosclerosis reversal", *Current Opinion in Lipidology*, 15(6), Abstract, (Dec. 2004), 645-649.
- Nissen, S. E., et al., "Effect of recombinant ApoA-I milano on coronary atherosclerosis in patients with acute coronary syndromes: a randomized controlled trial", *JAMA*, 290(17), (Nov. 2003), 2292-2300.
- Panagotopoulos, S. E., et al., "The role of apolipoprotein A-I helix 10 in apolipoprotein-mediated cholesterol efflux via the ATP-binding cassette transporter ABCA1", *Journal of Biological Chemistry*, 277(42), (2002), 39477-39484.
- Rader, D. J., "High-density lipoproteins and atherosclerosis", *American Journal of Cardiology*, 90(8), (Oct. 2002), 62-80.
- Shah, P. K., et al., "Effects of recombinant apolipoprotein A-I(Milano) on aortic atherosclerosis in apolipoprotein E-deficient mice", *Circulation, Journal of the American Heart Association*, 97, (1998), 780-785.
- Shah, P. K., et al., "High-dose recombinant apolipoprotein A-I milano mobilizes tissue cholesterol and rapidly reduces plaque lipid and macrophage content in apolipoprotein E-deficient mice: potential implications for acute plaque stabilization", *Circulation, Journal of the American Heart Association*, 103, (2001), 3047-3050.
- Vedhachalam, C., et al., "Influence of ApoA-I structure on the ABCA1-mediated efflux of cellular lipids", *Journal of Biological Chemistry (JBC)*, 279(48), (2004), 49931-49939.
- Ramprasad, Mysore P., et al., "Sustained-Delivery of an ApolipoproteinE-Peptidomimetic Using Multivesicular Liposomes Lowers Serum Cholesterol Levels", *Journal of Controlled Release*, Elsevier, Amsterdam, NL, vol. 79, No. 1-3, Feb. 19, 2002, XP004340926, ISSN: 0168-3659, (pp. 207-218).
- Definition of derivative and analog from <http://cancerweb.ncl.ac.uk/cgi-bin/omd?query=derivative>, (Jul. 7, 2005), 5 pages.
- "Designing Customs Peptides", SIGMA Genosys, http://www.sigma-genosys.com/peptide_design.asp, (Dec. 16, 2004), 2 pages.
- Abbott Cardiovascular Systems, Non Final Office Action dated Jun. 1, 2009 for U.S. Appl. No. 11/946,028.
- Berendsen, H., "A glimpse of the holy grail?", *Science*, vol. 282, www.sciencemag.org, (Oct. 1998), 642-643.
- Bradley, et al., "Limits of cooperativity in a structurally modular protein: response of the notch ankyrin domain to analogous alanine substitutions in each repeat", *J. Mol. Biol.*, 324, (2002), 373-386.
- Ngo, J. T., et al., "Computational complexity, protein structure prediction, and the Levinthal paradox", *The Protein Folding Problem and Tertiary Structure Prediction*, Birkhauser Boston, (1994), 491-495.
- Rudinger, J., "Characteristics of the amino acids as components of a peptide hormone sequence", *Peptide Hormones*, JA, Parsons Edition, University Park Press, (Jun. 1976), 1-7.
- Schinzel, R., et al., "The phosphate recognition site of *Escherichia coli* maltodextrin phosphorylase", *Federation of European Biochemical Societies*, vol. 286, No. 1,2, (Jul. 1991), 125-128.
- Voet, D., et al., "Abnormal Hemoglobins", *Biochemistry, Second Edition*, Section 9-3, (1995), 235-241.
- "Apo A-1 from Human", NCBI Accession No. P02647; Accessed Jun. 15, 2010, 1-14.
- Abbott Cardiovascular Systems, Final Office Action dated Jun. 17, 2010 for U.S. Appl. No. 11/946,028.
- Abbott Cardiovascular Systems, Non-Final Office Action mailed Jul. 21, 2010 for U.S. Appl. No. 11/858,862.
- Gu, et al., "Apolipoprotein A-1 from Beijing Duck", NCBI Accession No. AAB30359; Accessed Jun. 15, 2010, 1 page.
- Knott, et al., "Apolipoprotein from human", NCBI Accession No. CAA28583.1; Accessed Jun. 15, 2010, 1 page.
- Abbott Cardiovascular Systems, International search report and written opinion dated May 15, 2009 for PCT/US2008/012793.
- Luck, et al., "Plasma protein adsorption on biodegradable microspheres consisting of poly(D,L-lactide-co-glycolide), poly(L-lactide) or ABA triblock copolymers containing poly(oxyethylene)—Influence of production method and polymer composition", *Journal of Controlled Release*, Elsevier, vol. 55, No. 2-3, (Nov. 13, 1998), 107-120.
- Prokop, et al., "Nanovehicular intracellular delivery systems", *Journal of Pharmaceutical Sciences*, vol. 97, No. 9, (Sep. 2008), 3518-3590.
- Abbott Cardiovascular Systems, Non final office action mailed Oct. 19, 2010 for U.S. Appl. No. 11/946,026.
- Abbott Cardiovascular Systems, Non-final Office Action mailed Nov. 24, 2010 for U.S. Appl. No. 11/946,029.
- Abbott Cardiovascular Systems, International Preliminary Report on Patentability mailed Jun. 10, 2010 for PCT/US2008/012767.
- Abbott Cardiovascular Systems, International Preliminary Report on Patentability mailed Jun. 10, 2010 for PCT/US2008/012794.
- Abbott Cardiovascular Systems, International Preliminary Report on Patentability mailed Jun. 10, 2010 for PCT/US2008/012793.

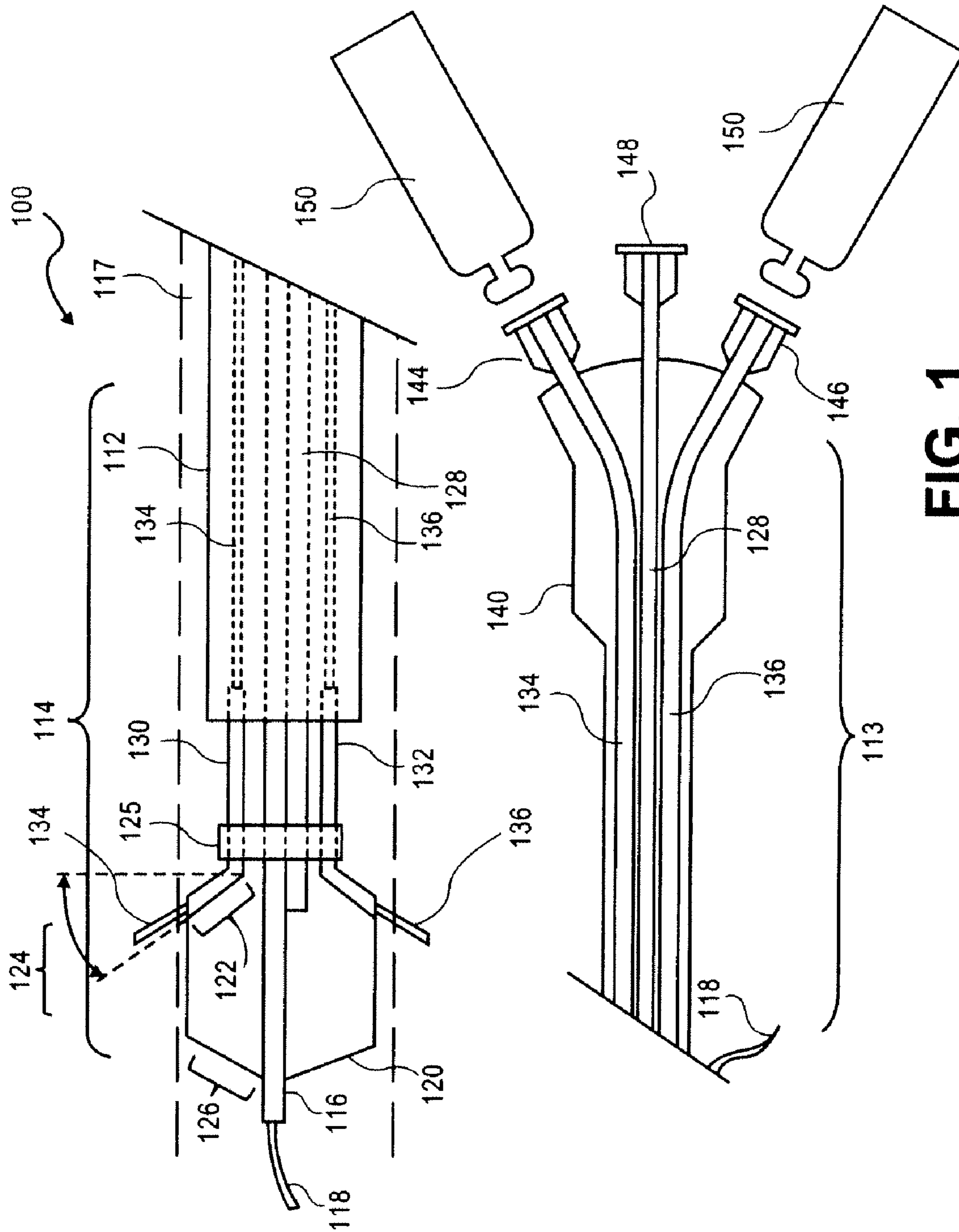

FIG. 1

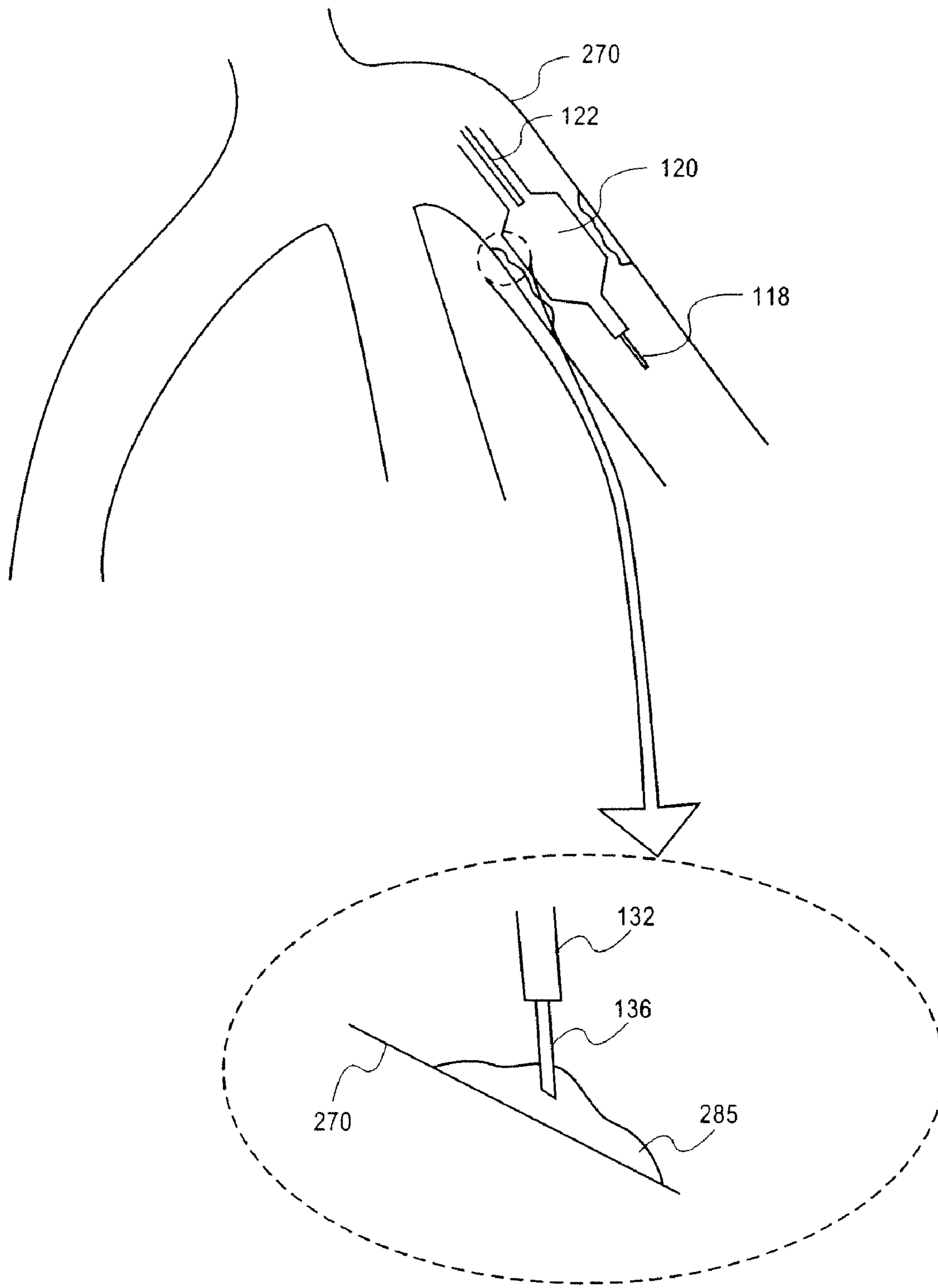

FIG. 2

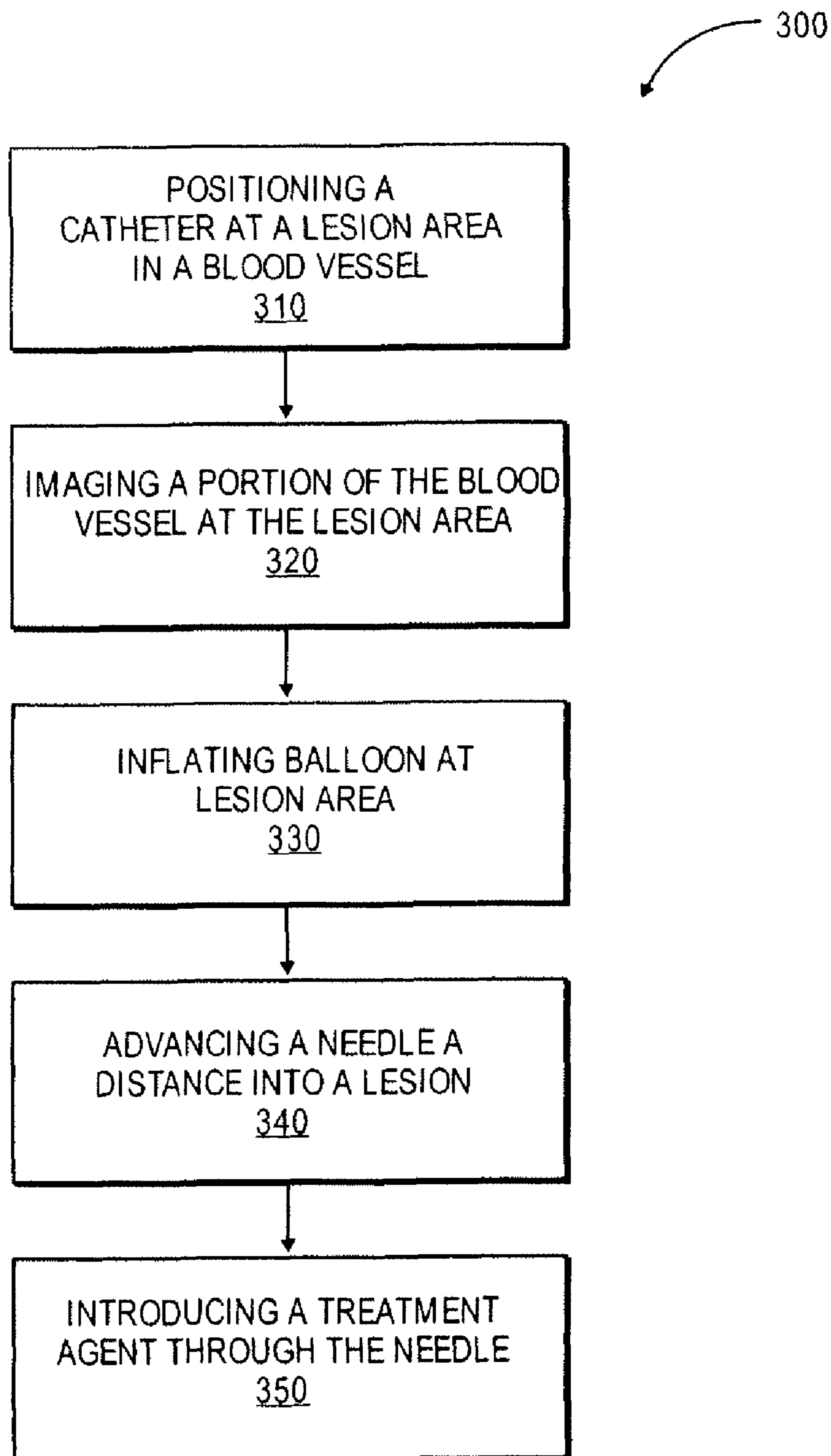

FIG. 3

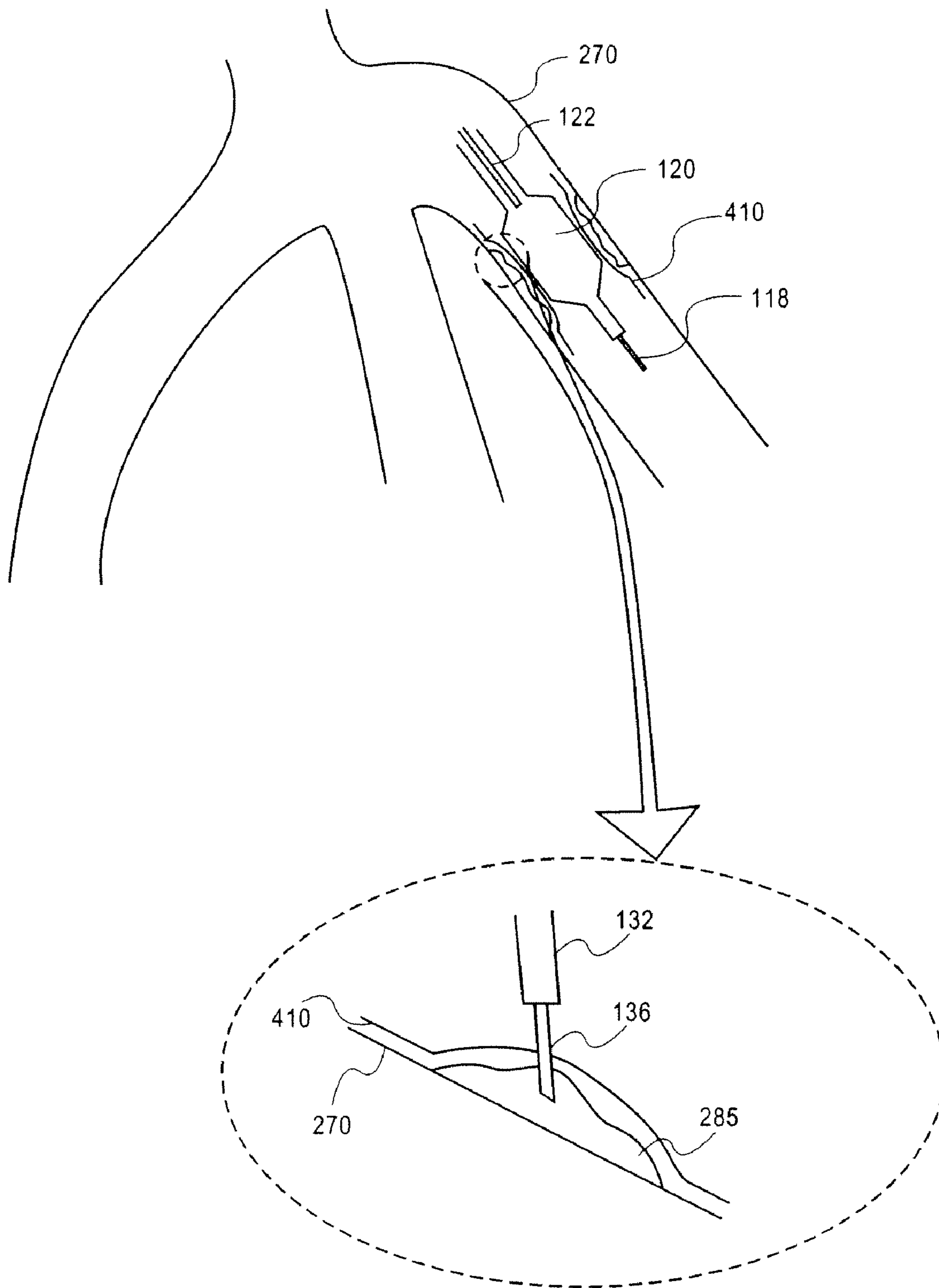

FIG. 4

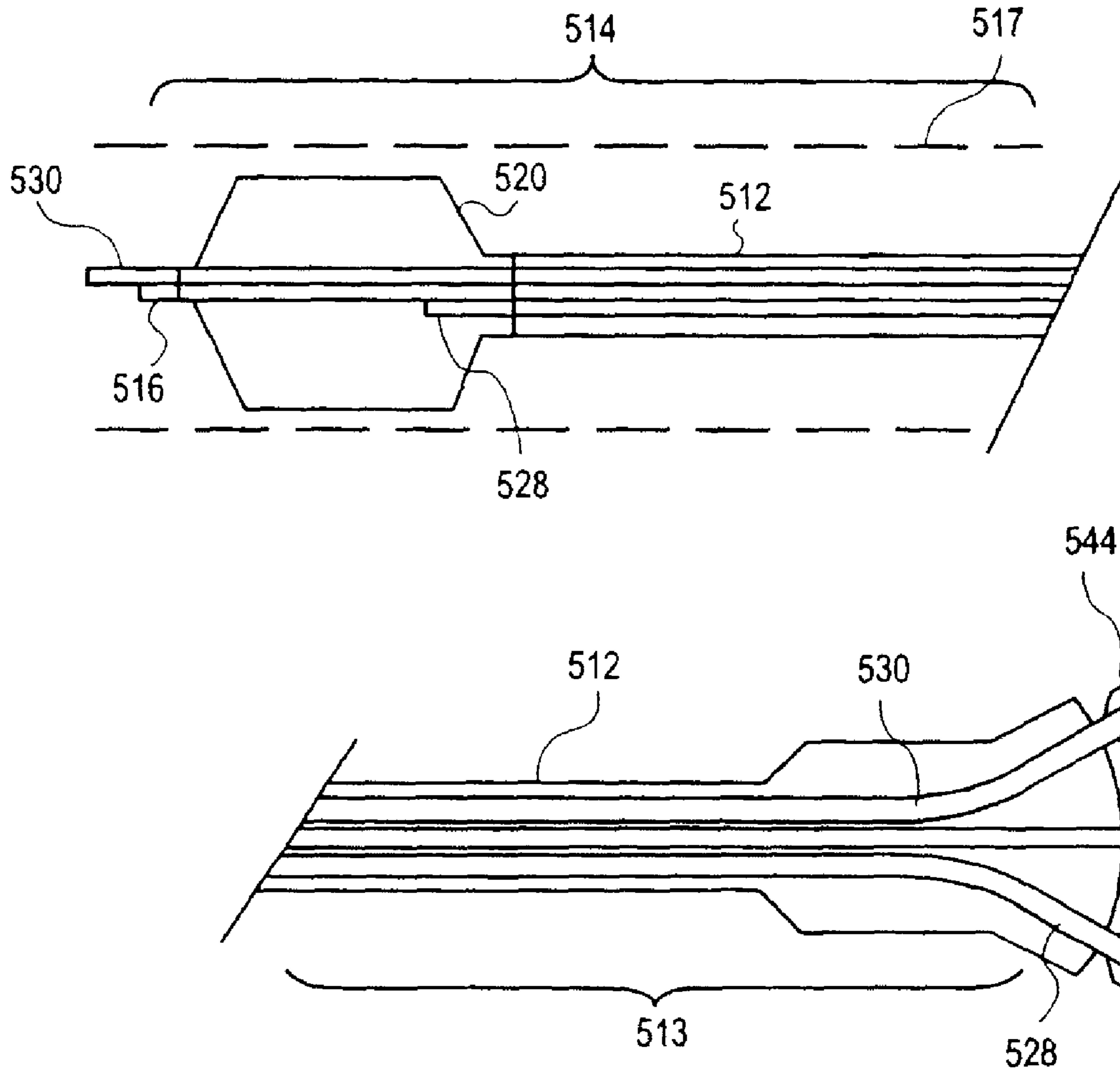

FIG. 5

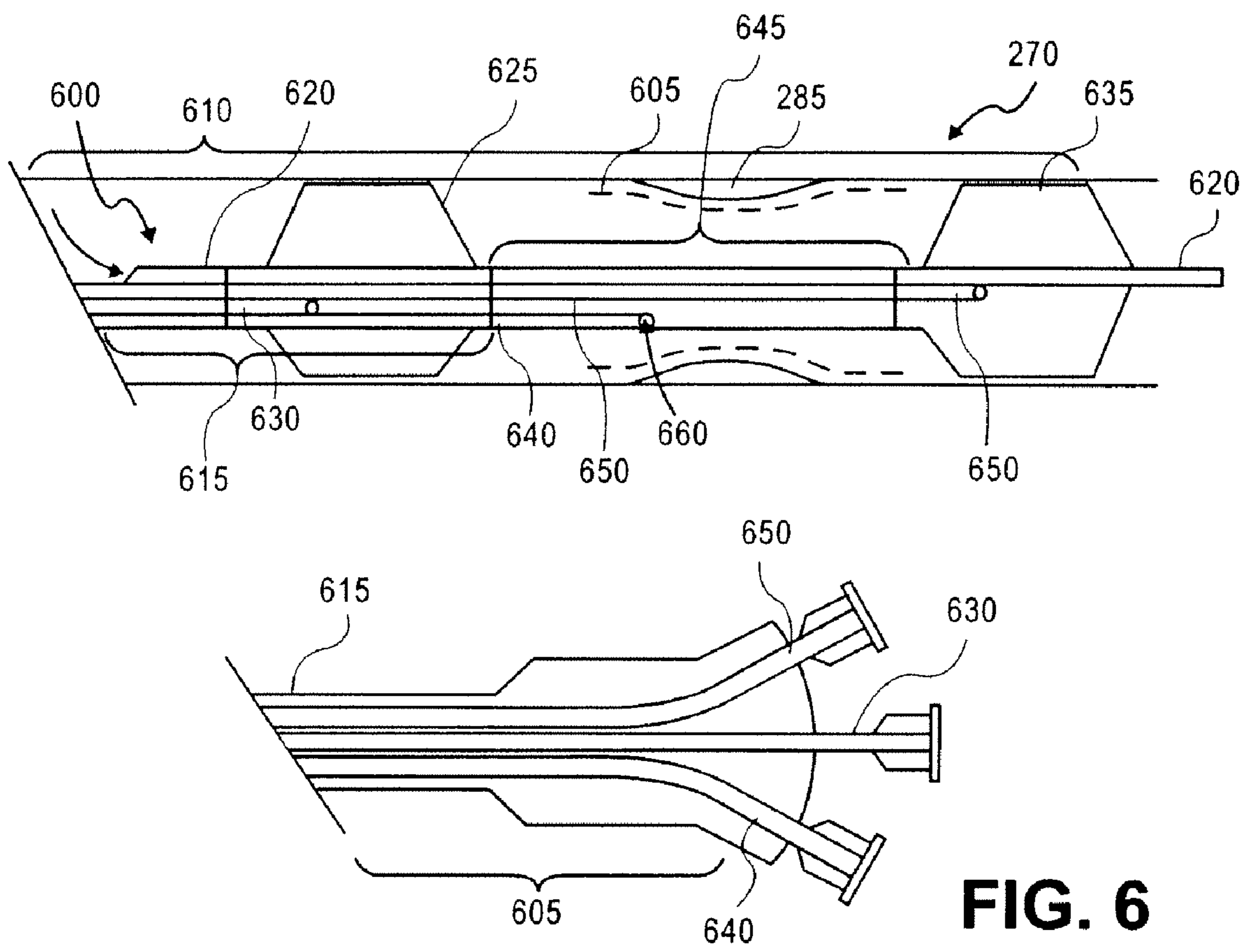

FIG. 6

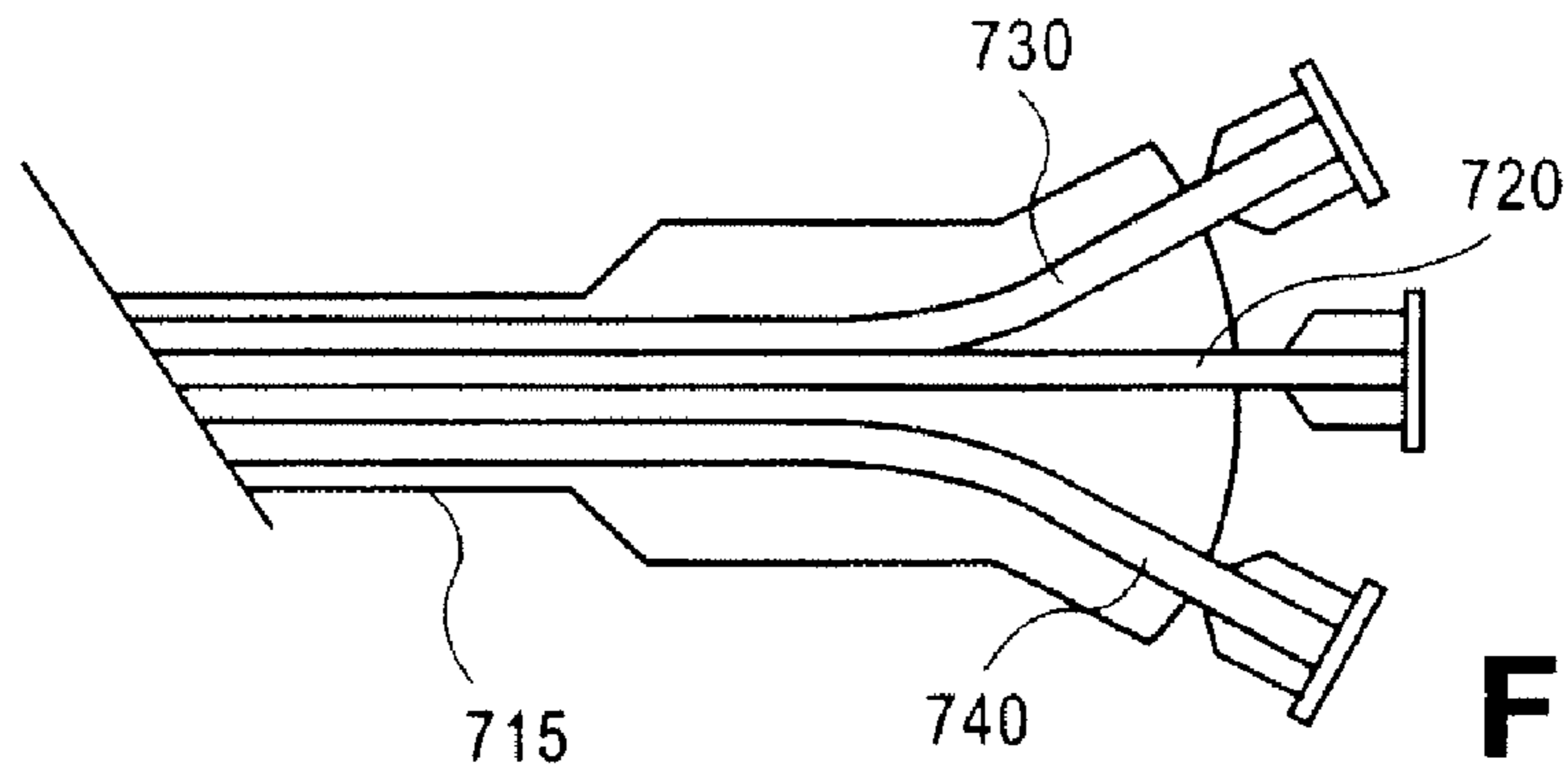
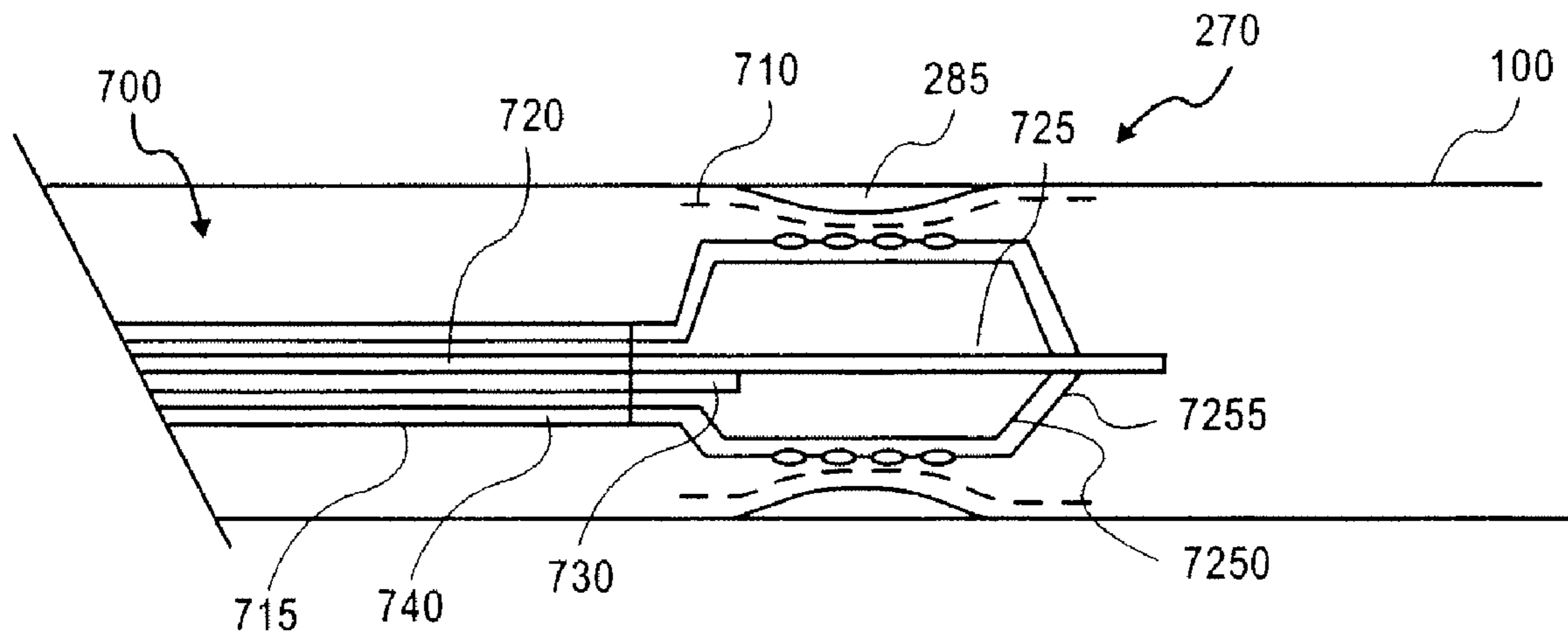

FIG. 7

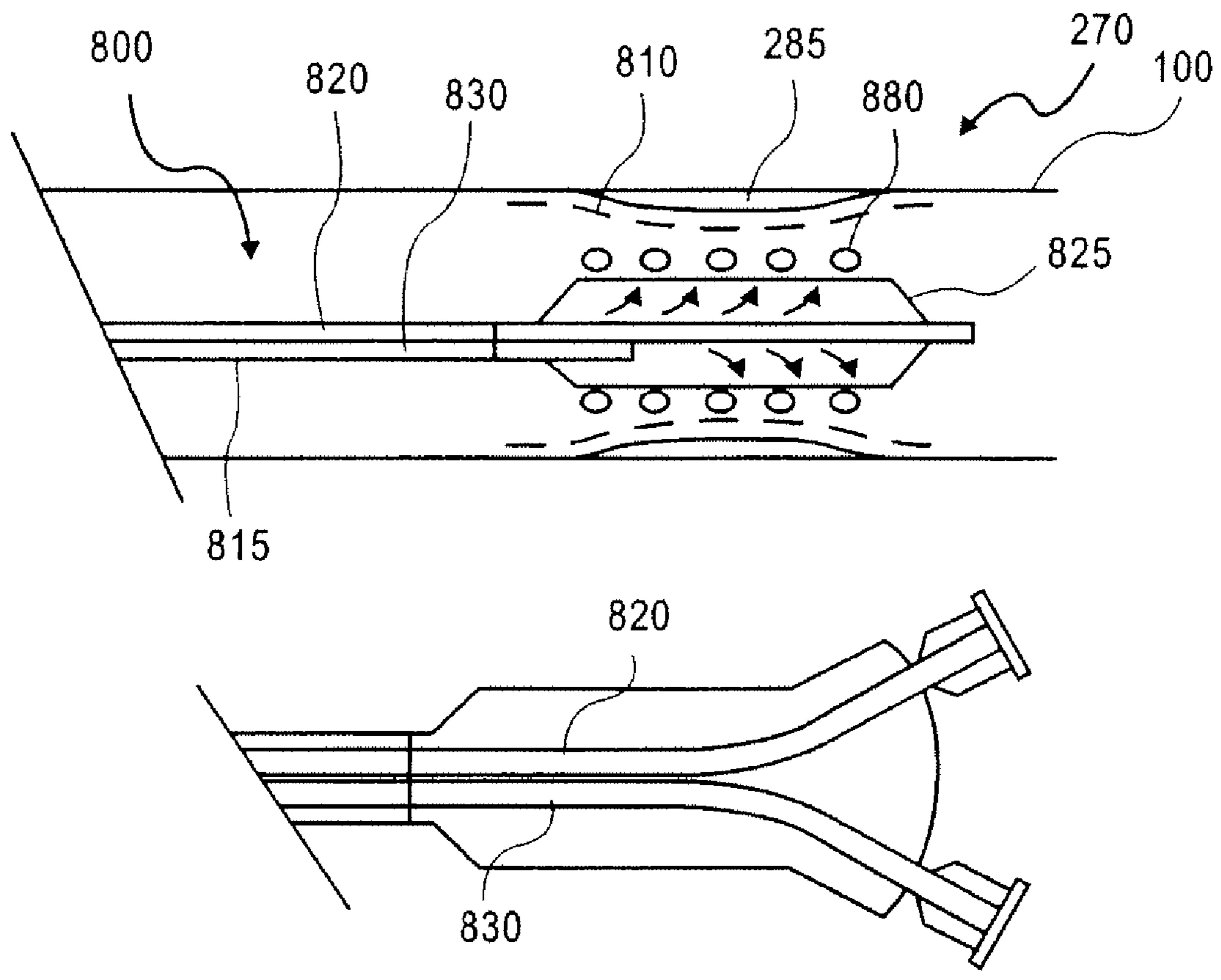

FIG. 8

1

APO A-I MIMETIC PEPTIDES AND
METHODS OF TREATMENT

SEQUENCE LISTING

A paper copy of the Sequence Listing entitled "56188514" is herein incorporated by reference. This Sequence Listing consists of SEQ. ID NOs:1-10.

FIELD

Compositions and methods for facilitating reverse cholesterol transport.

BACKGROUND

Cholesterol is a major component of atherosclerotic plaque. Cholesterol accumulation within atherosclerotic plaque occurs when cholesterol influx into an arterial wall exceeds cholesterol efflux. Increased influx of cholesterol into the arterial wall is accompanied by an increased influx of monocytes/macrophages, which absorb oxidized aggregated low density lipoproteins (LDL) and store the cholesterol esters.

Current strategies to reduce coronary heart disease are primarily directed at reducing the influx of cholesterol into the arterial wall by lowering LDL cholesterol concentration. While lowering of plasma LDL levels offers some protection from coronary heart disease, the protection is not complete. As a result, there is an interest in strategies aimed at enhancing cholesterol efflux from the arterial wall and promoting its transport to the liver for excretion.

Cholesterol circulating in the blood is carried by plasma lipoproteins. Plasma lipoproteins are classified into groups according to size. Of these, the low density lipoprotein (LDL) and high density lipoprotein (HDL) are primarily the major cholesterol carrier proteins. The protein component of LDL, apolipoprotein B (Apo B), constitutes the atherogenic component. Apo B is not present in HDL. HDL includes apolipoprotein A-1 (Apo A-I) and apolipoprotein A-II (Apo A-II) as well as other apolipoproteins.

component. Apo B is not present in HDL. HDL includes apolipoprotein A-1 (Apo A-I) and apolipoprotein A-II (Apo A-II) as well as other apolipoproteins.

Various forms of HDL have been described on the basis of electrophoretic mobility and include two major fractions: a first fraction with α -HDL mobility and another fraction referred to as pre- β HDL. Pre- β HDL is thought to be the most efficient HDL subclass for inducing cellular cholesterol efflux. Pre- β HDL fractions includes Apo A-I, phospholipids and free cholesterol. Pre- β HDL are considered to be acceptors of cellular free cholesterol and are believed to transfer free and esterified cholesterol to α -HDL.

Two pathways have been proposed to describe the movement of cholesterol from a plasma membrane to acceptor particles such as pre- β HDL. In the "aqueous diffusion pathway," cholesterol molecules spontaneously desorb from cell membranes and are then incorporated into acceptor particles (pre- β HDL) after traversing the intervening aqueous space by diffusion. It is believed that the aqueous diffusion pathway does not require interaction with specific cell receptors.

The second model, referred to as the "microsolubilization pathway," involves the interaction of HDL (presumably an Apo A-I interaction) with a cell surface binding site. The HDL induces an intracellular signal leading to translocation of cholesterol from intracellular sites to the plasma membrane.

2

The physiological acceptors or carriers for the translocated cholesterol are nascent HDL particles, including α -HDL and pre- β HDL.

Cholesterol that is transferred to nascent HDL particles is esterified by lecithin-cholesterol acyl transferase (LCAT) to cholesteryl esters. These esters are hydrophobic and tend to move into the core of the HDL particle. The HDL cholesteryl esters may return or be delivered to the liver and are excreted from the liver into bile, either directly or after conversion to bile cells.

It is believed that α -HDL and pre- β HDL particles, the primary acceptors or carriers for translocated cholesterol, do not occur in the same relative fractions as nascent HDL particle in the blood stream of an adult human. Thus, the carrier potential of each fraction is believed to be inversely proportional to its relative fraction of the total HDL quantity. In other words, the fraction with the highest carrier potential (pre- β HDL) occurs in the smallest overall amount in vivo.

SUMMARY

Compositions, methods and treatments for improving reverse cholesterol transport are disclosed. In one embodiment, a method includes advancing a delivery device through a lumen of a blood vessel to a particular region in the blood vessel and introducing a synthetic apolipoprotein A-1 (Apo A-I) mimetic peptide or a composition including a synthetic Apo A-I mimetic peptide into a wall of the blood vessel (e.g., into a lesion) at the particular region. A synthetic Apo A-I mimetic peptide or a treatment composition including a synthetic Apo A-I synthetic mimetic peptide may be used to induce regression of an existing plaque or to delay progression of an evolving atherosclerotic plaque. By introducing the synthetic Apo A-I mimetic peptide or composition including a synthetic Apo A-I mimetic peptide locally (e.g., into a lesion) or regionally (e.g., in or around an area immediately adjacent the lesion), it is anticipated that less treatment agent will be lost in the systemic circulation, thereby allowing smaller (lower) doses to provide longer duration therapy.

In another embodiment, a method is disclosed that includes local delivery of an Acyl CoA cholesterol: acyltransferase (ACAT) inhibitor alone or in combination (combination therapy) with a synthetic Apo A-I mimetic peptide. The ACAT inhibitor may be delivered in solution as a formulation with a carrier (e.g., liposome, polymerosome, micelle, micro-particle, nanoparticle) or coated on an implant or stent.

In other embodiments, compositions are disclosed which include at least one synthetic Apo A-I mimetic peptide in a form suitable for delivery into a blood vessel. In one embodiment, the Apo A-I mimetic peptide includes an amino acid sequence in an order reverse to an order of an endogenous peptide. In another embodiment, a composition is disclosed that includes an Apo A-I mimetic peptide with amino acids arranged in an endogenous order or in an order reverse to an order of an endogenous Apo A-I peptide such that the composition may be administered locally or systemically.

BRIEF DESCRIPTION OF THE DRAWINGS

FIG. 1 is a simplified cross-sectional view of an embodiment of a substance delivery apparatus in the form of a catheter assembly having a balloon and a therapeutic substance delivery assembly.

FIG. 2 schematically illustrates a portion of coronary artery network having a catheter assembly introduced therein.

FIG. 3 presents a block diagram for introducing a treatment composition.

3

FIG. 4 schematically illustrates a portion of a coronary artery network having a stent placed therein and a catheter assembly introduced therein.

FIG. 5 schematically illustrates a simplified cross-sectional view of a second embodiment of a substance delivery apparatus in the form of a catheter assembly having a balloon and a treatment agent delivery assembly.

FIG. 6 shows the blood vessel of FIG. 4 and a second embodiment of a catheter assembly to deliver a treatment agent introduced into the blood vessel.

FIG. 7 shows the blood vessel of FIG. 4 and a fourth embodiment of a catheter assembly to delivery a treatment agent introduced into the blood vessel.

FIG. 8 shows the blood vessel of FIG. 4 and a fifth embodiment of a catheter assembly to deliver a treatment agent introduced into the blood vessel.

DETAILED DESCRIPTION

The following embodiments describe techniques, compositions and devices directed, in one aspect, at improving reverse cholesterol transport by the aqueous diffusion pathway or the microsolvubilization pathway. As noted above, direct vascular protective effects of HDL have been attributed to Apo A-I or Apo A-I-associated molecules in HDL. Amphipathic helical peptides that mimic the actions of Apo A-I have been shown to have anti-atherogenic effects in animal models.

Endogenous Apo A-I molecule (human) is a single polypeptide chain with 243 amino acids consisting of ten 22-mer amphipathic α -helices in tandem. The majority of the α -helices, i.e., helices 1, 2 and 5-8 are class A helices, while the remainder, i.e., 3-4, 9-10 are class Y helices. Endogenous Apo A-I contains a globular N-terminal domain (residues 1 to 43) and a lipid-binding C-terminal domain (residues 44 to 243). Endogenous Apo A-I is synthesized by the liver and small intestine as a preproprotein (260 amino acid residues) which is secreted as a proprotein (249 amino acid residues) that is rapidly cleaved to generate a mature polypeptide having 243 amino acid residues.

In one embodiment, a synthetic Apo A-I mimetic peptide (hereinafter, referred to as the "mimetic peptide") is locally delivered. "Local delivery" of the mimetic peptide or a treatment composition including the mimetic peptide in this context includes delivery into a vessel wall or a lesion associated with a vessel wall such as a coronary vessel wall as opposed to delivery into the systemic circulation. Local delivery may provide enhanced delivery efficiency and minimize treatment agent (e.g., synthetic Apo A-I mimetic peptide) loss into the systemic circulation, thereby allowing application of lower doses and longer duration of activity. Local delivery also improves overall effectiveness in modulating coronary arterial response to injury.

According to some embodiments, a synthetic Apo A-I mimetic peptide "mimics" endogenous human Apo A-I in the sense that the mimetic peptide is capable of the removal of cholesterol, i.e., reverse cholesterol transport or efflux. In one embodiment, the mimetic peptide includes at least one class A amphipathic α -helix having positively charged amino acid residues clustered at a hydrophobic-hydrophilic interface and negatively-charged amino acid residues clustered at a center of a hydrophilic face. Other characteristic properties of Apo A-I mimetic peptides include peptides with a non-polar side of aromatic amino acids, like phenylalanine or tyrosine, and positively-charged amino acids (e.g., glutamic acid) between two α -helices having a suitable distance (e.g., approximately 3.6 amino acid residues).

4

Examples of suitable synthetic Apo A-I mimetic peptides that may be locally delivered include, but are not limited to:

- (i) An 18 amino acid peptide 4F (L-4F, D-4F), DWFKAFY-DKVAEKFKAEAF (SEQ ID NO: 1), and its homologs, derivatives and analogs;
- (ii) An 18 amino acid peptide, DWLKAIFYDKVAEK-LKEAF (SEQ ID NO: 2), and its homologs, derivatives and analogs; and
- (iii) A 33 amino acids peptide, PALEDLRQGLLPVLES-FKVFLSALEEYTKKLNTQ (SEQ ID NO: 3), and its homologs, derivatives and analogs.

As described, the 18-mer and 33-mer peptides begin at the amino end of a polypeptide chain (e.g., the peptide chain is read left to right starting with the amino-terminal residue). One of ordinary skill in the art would appreciate that "D" and "L" designations refer to the enantiomers of a compound based on the actual geometry of each enantiomer.

Other amphipathic helix peptides, such as Apo A-II and Apo J peptide, and the homologs, derivatives and analogs thereof are also suitable. Peptides may consist of D amino acids, L amino acids, a racemic backbone of D and L amino acids, or any mixture thereof. The N-terminal may be modified by components including, but not limited to, acetyl groups, and C-terminal carboxyl may be modified by components, including but not limited to, amides or esters. These modified peptide structures may provide protection against premature degradation. Examples of modified peptides include, but are not limited to

- (iv) An 18-mer peptide, 4F: Ac-DWFKAFYDKVAEK-FKEAF-NH₂ (SEQ ID NO: 4); and
- (v) A 33-mer peptide, helices 9/10: Ac-PALEDLRQGLLPVLESFKVFLSALEEYTKKLNTQ-NH₂ (SEQ ID NO: 5).

The amino acids represented by letters in the above examples and throughout this description are as follows:

| | | |
|---|-----|---------------|
| A | Ala | Alanine |
| C | Cys | Cysteine |
| D | Asp | Aspartic acid |
| E | Glu | Glutamic acid |
| F | Phe | Phenylalanine |
| G | Gly | Glycine |
| H | His | Histidine |
| I | Ile | Isoleucine |
| K | Lys | Lysine |
| L | Leu | Leucine |
| M | Met | Methionine |
| N | Asn | Asparagine |
| P | Pro | Proline |
| Q | Gln | Glutamine |
| R | Arg | Arginine |
| S | Ser | Serine |
| T | Thr | Threonine |
| V | Val | Valine |
| W | Trp | Tryptophan |
| Y | Tyr | Tyrosine |

The 18-mer D-4F peptide mimetic has been shown to be effective in reverse cholesterol transport without a lipid complex. However, this peptide may be administered in the form of a phospholipid complex as can other peptides described herein. Incompletely lipidated endogenous Apo A-I, existing as a flexible conformation or molten globular state, is known to readily associate with lipids due to its amphipathic α -helical segments. Thus, mimetic peptides according to embodiments of the invention are expected to similarly associate with lipids due to inclusion of at least one amphipathic α -helical segment. In one embodiment, a synthetic Apo A-I mimetic

5

peptide may be formulated as a complex with a phospholipid such as dimyristoyl phosphocholine (DMPC) to form a lipid complex. Both 18-mer L-4F and D-4F mimetic peptides have been shown to function more effectively in reverse cholesterol transport in vitro when a phospholipid complex is presented. The 33-mer peptide mimetic, in particular, requires phospholipid complex formation for effective reverse cholesterol transport.

In one embodiment, a synthetic Apo A-I peptide mimetic is part of a delivery composition. In addition to the peptide mimetic, the composition may include a phospholipid such as DMPC and a buffer such as phosphate buffered saline (PBS) that may serve to maintain an osmotic pressure and control the pH of the delivery composition. As noted above, the phospholipid component is optional, particularly with peptides that have demonstrated an ability to function in a non-complex form, such as the 18-mer L-4F and D-4F.

As noted above, endogenous Apo A-I molecule (human) is a single polypeptide chain with 243 amino acids consisting of 10 amphipathic α -helices. One unit of helix turns consistently and includes 3.6 amino acid residues. Therefore, even though a peptide sequence is reversed, a relative location of hydrophobic and hydrophilic side chains is similar to the original peptide when peptides form α -helix structure. Thus, in another embodiment, a suitable Apo A-I synthetic mimetic peptide for atherosclerosis treatment (e.g., reverse cholesterol transport) is a peptide including amino acids arranged in an order reverse to the order of an endogenous Apo A-I peptide or a portion thereof.

Examples of reverse sequence Apo A-I synthetic peptide (with optionally modified N- and C-terminals) include, but are not limited to:

- (vi) Ac-FAEKFKAEVAVKDYFAKFW-NH₂ (SEQ ID NO: 6) (4F);
- (vii) Ac-FAEKLKEAVKDYFAKLWD-NH₂ (SEQ ID NO: 7); and
- (viii) Ac-NLKKTYEELASLFSVKFSELV-PLLGQRLDELAP-NH₂ (SEQ ID NO: 8).

The reverse sequence Apo A-I peptides may be formulated as phospholipid complexes and/or prepared as a treatment composition with, for example, a buffer as described above.

Work with the secondary structure of Apo A-I has identified helix 1 as having high lipid binding affinity. The chimera of helices 1 and 9 has demonstrated high hydrophobicity and an acceptable phospholipid arrangement (e.g., DMPC clearance). Thus, in one embodiment, a suitable Apo A-I synthetic peptide mimetic for atherosclerosis therapy is a chimera of helices 1 and 9. The peptides may be represented as follows:

- (iv) 1/9 chimera: Ac-LKLLDNWDSVTSTFSKLREQLG-PALEDLRQGLL-NH₂ (SEQ ID NO: 9); and
- (x) 9/1 chimera: Ac-PALEDLRQGLLPLKLLDNWDSVTSTFSKLREQLG-NH₂ (SEQ ID NO: 10).

In this context, a chimera is a recombinant DNA molecule containing unrelated genes in the sense that the genes are each not a component of the same α -helix of the 10 α -helices of endogenous Apo A-I.

In the embodiments of the chimera of helices 1 and 9 described above, the peptides may be modified (as shown) with an N-terminal acetyl group and a C-terminal amide or ester to stabilize the amphipathic nature of the helices. The peptides may further be formulated as phospholipid complexes with, for example, DMPC, to act as an acceptor for cholesterol and/or prepared as a treatment composition with, for example, a buffer. The peptides may be synthesized or fabricated by recombinant methods with L- or D-amino acids. Still further, the reversed sequences should have similar potency.

6

Example

The mimetic peptides described here can be synthesized by both Di-tert-butylidicarbonate (Boc)-, and N- α -(9-Fluorenylmethoxycarbonyl)-N- γ -trityl-L-asparagine (Fmoc)-based solid phase synthesis. Described herein is Fmoc-based solid phase peptide synthesis. Rink amide resins, for example, Rink Amide MBHA resin, or Fmoc-PAL-PEG-PS resin are used to install carboxyamides at the C-terminus of the synthesized peptides. For peptides with unmodified C-terminus, Wang resin is used for solid phase peptide synthesis (SPSS). Any other resins for SPSS can be used to synthesize peptides according to embodiments of the invention. Upon completion of peptide synthesis, if necessary, the peptide N-terminus is modified by treatment with, for example, acetic anhydride (10 eq.) and diisopropylethylamine (DIPEA) (10 eq.), or any carboxylic acid derivatives (2-5 eq.) in N,N-dimethylformamide (DMF)/dichloromethane (DCM) (1:1, v/v) with coupling reagent (2-5 eq.) and base (2-5 eq.). Side chain protection groups were removed and the peptide is simultaneously cleaved from the resin with cleavage cocktails, such as Reagent K, or 94% trifluoroacetic acid (TFA), 2.5% water, 2.5% ethanedithiol (EDT), and 1% triisopropylsilane (TIS) for cysteine-containing peptide, or any other appropriate cleavage cocktails. Purification of peptides was performed by preparative high performance liquid chromatography (HPLC) or liquid chromatography/mass spectrometry (LC/MS) with a water/acetonitrile gradient containing 0.1% TFA or formic acid. When necessary, counter ion can be exchanged to another acid, such as acetic acid. For amino acid coupling, the following coupling reagent can be used (but other reagents can also be used for peptide synthesis): N,N'-dicyclohexyl-carbodiimide (DCC), benzotriazole-1-yl-oxy-tris-(dimethylamino)-phosphonium hexafluorophosphate (BOP), benzotriazole-1-yl-oxy-tris-pyrrolidino-phosphonium hexafluorophosphate (PyBOP), (1H-Benzotriazol-1-yl)1,1,3,3-tetramethyluronium hexafluorophosphate (HBTU), 1H-Benzotriazolium-1-[bis(dimethylamino)methylene]tetrafluoroborate-(1,3)-oxide (TBTU), 2-(5-norbornene-2,3-dicarboximido)-1,1,3,3-tetramethyluronium tetrafluoroborate (TNTU), O-(N-succinimidyl)-N,N,N',N'-tetramethyluronium tetrafluoroborate (TSTU), and bromotris-pyrrolidino phosphoniumhexafluorophosphate (Py-BrOP). 1-Hydroxybenzotriazole anhydrous (HOBt) can be added to the reaction mixture to prevent side reaction and act as catalyst.

Combination Therapies

Acyl CoA Cholesterol: Acyltransferase

Apo A-I or Apo A-I-related molecules (e.g., peptides) have been shown to remove cholesterol from atherosclerotic lesions through reverse cholesterol transport. In general, Apo A-I has the ability to remove free cholesterol from cell membranes, however, esterified cholesterol mainly located in lipid droplets may not be directly removed by reverse cholesterol transport.

Acyl CoA cholesterol: acyltransferase (ACAT) is an enzyme that converts free cholesterol into cholesterol esters, and is responsible for the deposition of cholesterol in cells as cholesterol esters. Inhibition of the enzyme can increase the amount of free cholesterol that can be removed by Apo A-I. In addition, oral administration of an ACAT inhibitor in rabbits prevents intimal hyperplasia induced by balloon injury through prevention of foam cell accumulation, and the effect appears independent of plasma cholesterol concentration.

ACAT is a membrane protein and the active center is located inside of the membrane. Thus, most ACAT inhibitors are highly hydrophobic and are therefore inadequate for oral administrations.

In another embodiment, a method of local or regional delivery of an ACAT inhibitor is described. The ACAT inhibitor may be delivered as a single treatment agent or in combination with Apo A-I therapy as described in embodiments of the invention. Local administration of ACAT inhibitors to the blood vessels in combination with Apo A-I can maximize reverse cholesterol transport (e.g., reverse cholesterol efflux). This may improve the suppression of lipid accumulation in macrophage, of macrophage activity, and of smooth muscle cell proliferation. In addition, potential over-production of free cholesterol by inhibition of ACAT, which could cause cell damage, may be minimized by the treatment with Apo A-I peptide. The amount of ACAT inhibitors in regional therapy formulations would be small and systemic exposure of the ACAT inhibitors would be negligible, thus, inherent side effects of ACAT inhibitors, such as liver and adrenal toxicity can be circumvented. Examples of ACAT inhibitors are listed as follows, but other ACAT inhibitors may be used as well: CP 113,818 (Pfizer), C1-1011 (Pfizer), (Avasimibe), CI976, CL-277,082, Eflucimibe (bioMrieux-Pierre Fabre/Eli Lilly), CS-505 (Sankyo Pharma/Kyoto Pharma), (Pactimibe), KY-455 (Kyoto Pharma), F-1394 (Fujirebio Inc.), F 12511, NTE-122 (Nissin Food Products Co., Ltd.), PD 140296 (Parke-Davis), PD 128042 (Parke-Davis), PD 132301-2 (Parke-Davis), (Octimibate), DuP 128, DuP 129, 58-035 (Sandoz), HL-004, SMP-500 (Sumitomo Pharma), SMP-797, SM-32504 (Sumitomo Pharma), SKF-99085 (Glaxo Smith-Kline), E5324, R-755 (Nihon Nohyaku), FR145237 (Fujisawa Pharmaceutical Co., Ltd.), FR129169 (Fujisawa Pharmaceutical Co., Ltd.), FR186054, YM-17E (Yamanouchi Pharma), YM750 (Yamanouchi Pharma), Tamoxifen, MCC-147, YIC-708-424 (Yakult), TS-962 (Taisho), K-604 (Kowa), FCE-28654A (Pharmacia & Upjohn Inc.), CEB-925 (Wyeth).

In some embodiments, the ACAT inhibitor can be encapsulated, suspended, disposed within or loaded into a biodegradable carrier. Examples of biodegradable carriers include, but are not limited to, a liposome, a polymerosome, a micelle, a particle and a gel. Examples of particles include, but are not limited to, a microparticles and nanoparticles. In some embodiments, the biodegradable carrier is formulated such that it is bioerodable when present in physiological conditions.

In one embodiment, the biodegradable carrier for an ACAT inhibitor is a liposome. Liposomes are artificial vesicles that are approximately spherical in shape and can be produced from natural phospholipids, sphingolipids, ceramides, cholesterol or estradiol. Generally, a liposome has a lipid bilayer membrane encapsulating an aqueous solution, i.e., "core." The lipid bilayer membrane allows for fusion with an endogenous (or exogenous) cell membrane, which, similar to the liposome, comprises a semipermeable lipid bilayer. In one example, the peptide mimetic may be included in the lipid bilayer of the liposome (as opposed to within the core). This can be achieved either during liposome formation or in a post-insertion method. It is anticipated that such an embodiment will provide simultaneous extraction of cholesterol from a vulnerable plaque lesion and a potential for alteration of liposomal structure rigidity resulting in altered mass transport properties.

In one method, phospholipids and synthetic Apo A-I mimetic peptide are mixed with estradiol in chloroform. Suitable phospholipids include, but are not limited to, dimyris-

toylphosphatidylcholine (DMPC), dipalmitoyl phosphatidyl ethanolamine (DPPE), 1,2-dilauroyl-sn-glycero-3-phosphocholine (DLPC), 1,2-dimyristoyl-sn-glycero-3-phosphocholine (DMPC), 1,2-dipalmitoyl-sn-glycero-3-phosphocholine (DPPC), 1,2-dioleoyl-sn-glycero-3-phosphocholine (DOPC), 1,3-bis(sn)-phosphatidyl-sn-glycero-3-phosphocholine (POPC), Egg phosphatidylcholine (EPC), hydrogenated egg phosphatidylcholine (HEPC), soybean phosphatidylcholine (SPC), hydrogenated soybean phosphatidylcholine (HSPC). The liposomes may also be hydrophilically modified by coating with an agent such as poly(ethylene glycol) or dextran. Such coating tends to avoid detection from the body's immune system. After mixing, the solvent (and optional co-solvent) can be evaporated with heat or ambient temperature in a round bottom flask. Resultant lipids will be deposited on the glass surface. The deposited lipid film will be re-suspended in aqueous solution to form multilamellar (or unilamellar) vesicles, and extruded to prepare appropriate sized liposomes. Liposomes can be in a range from about 25 nm to about 2000 nm.

In another embodiment, the biodegradable carrier for an ACAT inhibitor is a polymerosome. "Polymerosomes" are polymer vesicles formed from di-block or tri-block copolymers with blocks of differing solubility. Polymerosomes may be formed by methods such as film rehydration, electroformation and double emulsion. In some methods, a similar manufacturing technique can be used as that of a liposome to form polymerosomes. For example, a polymerosome can be a di-block copolymer including a block which is hydrophobic, e.g., poly lactic acid, polycaprolactone, n-butyl acrylate, and another block which is hydrophilic, e.g., poly(ethylene glycol), poly(acrylic acid). A polymerosome can be in a range from between about 25 nm to about 2000 nm.

In another embodiment, the biodegradable carrier for an ACAT inhibitor is a micelle. A "micelle" is an aggregate of surfactant or polymer molecules dispersed in a liquid colloid. Micelles are often globular in shape, but other shapes are possible, including ellipsoids, cylinders, bilayers, and vesicles. The shape of a micelle is controlled largely by the molecular geometry of its surfactant or polymer molecules, but micelle shape also depends on conditions such as temperature or pH, and the type and concentration of any added salt.

Micelles can be formed from individual block copolymer molecules, each of which contains a hydrophobic block and a hydrophilic block. The amphiphilic nature of the block copolymers enables them to self-assemble to form nanosized aggregates of various morphologies in aqueous solution such that the hydrophobic blocks form the core of the micelle, which is surrounded by the hydrophilic blocks, which form the outer shell. The inner core of the micelle creates a hydrophobic microenvironment for a non-polar treatment agent, while the hydrophilic shell provides a stabilizing interface between the micelle core and an aqueous medium. Examples of polymers which can be used to form micelles include, but are not limited to, polycaprolactone polyethylene oxide blocks, polyethylene oxide- β -polypropylene oxide- β -polyethyleneoxide triblock copolymer and copolymers which have a polypeptide or polylactic acid core-forming block and a polyethylene oxide block. A micelle can be in a range from between about 10 nm to about 100 nm.

In another embodiment, the biodegradable carrier for an ACAT inhibitor is a nano or micro-particle. Various methods can be employed to formulate and infuse or load the particles with an ACAT inhibitor. Representative methods include, but are not limited to, water/oil/water emulsion, electrohydrodynamic atomization, and electrospraying. In one example, the

particles are prepared by a water/oil/water ($W_1/O/W_2$) double emulsion method. In the W_1 phase, an first aqueous phase is dispersed into the oil phase consisting of polymer (or other platform) dissolved in organic solvent (e.g., dichloromethane) and the synthetic Apo A-I mimetic peptide (ac-

5 according to embodiments of the invention) using a high-speed homogenizer. Examples of polymers include, but are not limited to, poly(L-lactide-co-glycolide) (PLGA), poly(D,L-lactide-co-glycolide), poly(L-lactide), poly(D,L-lactide) (PLA), poly(ϵ -caprolactone), poly(L-lactide-co-caprolac-

10 tone), poly(D,L-lactide-co-caprolactone), cross-linked poly(ethylene glycol) (PEG), PLA-PEG co-polymers, poly-esteramide co-polymers (PEA), and polyphosphazines. Additionally, collagen, gelatin, fibrin, or alginate may be used as a platform. The primary water-in-oil (W/O) emulsion is then dispersed in a second aqueous solution containing a polymeric surfactant, e.g., poly(vinyl alcohol) (PVA) or PEG, and further homogenized to produce a W/O/W emulsion. After stirring for several hours, the particles are collected by filtration. A microparticle can be in a range from about 5 μm to about 200 μm , preferably 10 μm to 50 μm . A nanoparticle can be in a range from between about 10 nm to about 500 nm, preferably about 50 nm to about 300 nm.

Delivery Methods

In one embodiment, a method includes advancing a delivery device through a lumen of a blood vessel to a particular region in a blood vessel such as a lesion area in a coronary atherosclerotic region. An Apo A-I synthetic mimetic peptide or a combination therapy thereof is then introduced into or adjacent to a wall of the blood vessel at the lesion area. By introducing the Apo A-I synthetic mimetic peptide into the lesion area, significantly less peptide may be used relative to the amount that might be used in a systemic delivery treatment regimen. One of ordinary skill in the art would know that the amount of mimetic peptide is given in various dosages, including maximum and minimum amounts. In one embodiment, an amount target of a five microgram Apo A-I peptide/kilogram ($\mu\text{g}/\text{kg}$) for an adult human is suitable. The delivery device may also be used to introduce an ACAT inhibitor(s), possibly in similar amounts, into or beyond the blood vessel at or adjacent the lesion area to effectuate a combination therapy thereby increasing efficacy of the reverse cholesterol transport.

Referring now to the drawings, FIG. 1 illustrates one embodiment of a delivery apparatus. In general, the delivery apparatus provides a system for delivering an Apo A-I synthetic peptide or a treatment composition including an Apo A-I synthetic peptide, to or through a desired area of a blood vessel (a physiological lumen) or tissue in order to treat a localized area of the blood vessel. The delivery apparatus is similar in certain respects to the delivery apparatus described in commonly-owned, U.S. patent application Ser. No. 09/746,498 (filed Dec. 21, 2000), titled "Local Drug Delivery Catheter with Retractable Needle," of Chow et al. (issued as U.S. Pat. No. 6,692,466) and U.S. patent application Ser. No. 10/749,354 (filed Dec. 31, 2003), titled "Modified Needle Catheter for Directional Orientation Delivery" of Chan, et al. Each of these applications is incorporated herein by reference. The delivery apparatus described is suitable, in one embodiment, for a percutaneous delivery of a treatment agent where a desired form of the treatment agent is introduced through a single catheter needle.

Referring to FIG. 1, the delivery apparatus includes catheter assembly 100, which is intended to broadly include any medical device designed for insertion into a blood vessel or physiological lumen to permit injection and/or withdrawal of fluids, to maintain the patency of the lumen, or for any other

purpose. In one embodiment, catheter assembly 100 is defined by elongated catheter body (cannula) 112 having proximal portion 113 and distal portion 114. In one embodiment, proximal portion 113 may reside outside a patient during a procedure while distal portion 114 is placed at a treatment site, for example, within coronary blood vessel 117.

Catheter assembly 100 includes catheter body 112 having a lumen therethrough extending from proximal portion 113 to distal portion 114. In this example, guidewire cannula 116 is formed within catheter body 112 for allowing catheter assembly 100 to be fed and maneuvered over a guidewire (guidewire 118 shown at this point within a lumen of guidewire cannula 116). Guidewire cannula 116 may extend from proximal portion 113 to distal portion 114, thus describing an over the wire (OTW) assembly. In another embodiment, typically described as a rapid exchange (RX) type catheter assembly, guidewire cannula 116 extends only through a portion of catheter body 112, for example, beginning and ending within distal portion 114. An RX type catheter assembly is shown. It is appreciated that guidewire 118 may be retracted or removed once catheter assembly 100 is placed at a region of interest, for example, within a blood vessel (e.g., artery or vein).

In the embodiment of FIG. 1, catheter assembly 100 includes balloon 120 incorporated at distal portion 114 of catheter assembly 100. Balloon 120 is an expandable body in fluid communication with inflation cannula 128 disposed within catheter body 112. Inflation cannula 128 extends from balloon 120 within distal portion 114 through inflation port 148 at proximal portion 113 (e.g., at a proximal end of catheter assembly 100). Inflation cannula 128 is used to deliver a fluid to inflate balloon 120.

In the embodiment shown in FIG. 1, balloon 120 is in an expanded or inflated state that occludes blood vessel 117. Balloon 120 is selectively inflatable to dilate from a collapsed configuration to a desired or controlled expanded configuration. Balloon 120 can be selectively inflated by supplying a fluid (e.g., liquid) into a lumen of inflation cannula 128 at a predetermined rate of pressure through inflation port 148. Likewise, balloon 120 is selectively deflatable to return to a collapsed configuration or deflated profile.

In one embodiment, balloon 120 can be defined by three portions: distal taper wall 126, medial working length 124, and proximal taper wall 122. In one embodiment, proximal taper wall 122 can taper at any suitable angle θ , typically between about 15° to less than about 90° , when balloon 120 is in an expanded (inflated) configuration.

Balloon 120 can be made from any suitable material, including, but not limited to, polymers and copolymers of polyolefins, polyamides, polyester and the like. The specific material employed should be compatible with inflation or expansion fluid and must be able to tolerate the pressures that are developed within balloon 120. One suitable material is an elastomeric nylon such as PEBAXTM, a condensation polymerized polyether block polyamide. PEBAXTM is a trademark of ATOCHEM Corporation of Puteaux, France. Other suitable materials for balloon 120 include, but are not limited to, a biocompatible blend of polyurethane and silicone, or a styrenic block copolymer (SBC) or blend of SBCs. Distal taper wall 126, medial working length 124, and proximal taper wall 122 can be bound together by seams or be made out of a single seamless material. A wall of balloon 120 (e.g., at any of distal taper wall 126, medial working length 124 and/or proximal taper wall 122) can have any suitable thickness so long as the thickness does not compromise properties that are critical for achieving optimum performance. Relevant properties include, but are not limited to, high burst strength, low

11

compliance, good flexibility, high resistance to fatigue, the ability to fold, the ability to cross and recross a desired region of interest or an occluded region in a physiological lumen and low susceptibility to defects caused by handling. By way of example, not limitation, a suitable thickness of a balloon wall can be in the range of about 0.0005 inches to 0.002 inches, the specific specifications depending on the procedure for which balloon 120 is to be used and the anatomy and size of the target lumen in which balloon 120 is to be inserted.

Balloon 120 may be inflated by the introduction of a fluid (e.g., liquid) into inflation cannula 128 (through inflation port 148 at a point outside a physiological lumen). Liquids containing therapeutic and/or diagnostic agents may be used to inflate balloon 120. In one embodiment, balloon 120 may be made of a material that is permeable to such therapeutic and/or diagnostic agents thus providing a method of delivering a therapeutic and/or diagnostic agent at a treatment site in addition to an Apo A-I peptide, a treatment composition including an Apo A-I peptide or an ACAT inhibitor. To inflate balloon 120, a suitable fluid may be supplied into inflation cannula 128 at a predetermined pressure, for example, between about one and 20 atmospheres (atm). A specific pressure depends on various factors, such as the thickness of the balloon wall, the material of which balloon 120 is made, the type of substance employed, and the flow rate that is desired.

Catheter assembly 100, in the embodiment shown in FIG. 1 also includes delivery cannula 130 and delivery cannula 132 each connected to proximal taper wall 122 of balloon 120 and extending at a proximal end, in one embodiment, into a portion of catheter body 112 of catheter assembly 100. Representatively, a suitable length for delivery cannula 130 and delivery cannula 132 is on the order of three to 6.5 centimeters (cm). Delivery cannula 130 and delivery cannula 132 can be made from any suitable material, such as polymers and copolymers of polyamides, polyolefins, polyurethanes, and the like. Catheter assembly 100, in this view, also includes needle 134 and needle 136. Needle 134 and needle 136 extend from distal portion 114 to proximal portion 113 of catheter assembly 100. At distal portion 114, needle 134 is slidably disposed through a lumen of delivery cannula 130 and needle 136 is slidably disposed through a lumen of delivery cannula 132. Thus, a dimension of delivery cannula 130 and delivery cannula 132 are each selected to be such to allow a delivery device such as a needle to be moved therethrough. Representatively, delivery cannula 130 has an inner diameter (lumen diameter) on the order of 0.002 inches to 0.020 inches (e.g., 0.0155 inches) and an outer diameter on the order of 0.006 inches to 0.05 inches (e.g., 0.0255 inches). FIG. 1 shows catheter assembly 100 with each of needle 134 and needle 136 deployed in an extended configuration, i.e., extending from an end of delivery cannula 130 and delivery cannula 132, respectively. In a retracted configuration, the needles retract proximally into the delivery cannula lumens. Although two needles are shown, in another embodiment, catheter assembly may include only a single needle (and single delivery cannula) or may include more than two needles (and more than two delivery cannulas).

FIG. 1 shows delivery cannula 130 and delivery cannula 132 each connected to an exterior surface of balloon 120. Specifically, a distal end of each of delivery cannula 130 and delivery cannula 132 extend to a point equivalent to or less than a length of proximal taper wall 122 of balloon 120. One suitable technique for connecting delivery cannula 130 or delivery cannula 132 to balloon 120 is through an adhesive. A

12

suitable adhesive includes a cyanoacrylate (e.g., LOCTITE 414™) adhesive, particularly where the balloon material is a PEBAX™ material.

Catheter assembly 100 in the embodiment shown in FIG. 1 also includes sheath ring 125. Sheath ring 125 is positioned over, in this embodiment, guidewire cannula 116, inflation cannula 128, delivery cannula 130, and delivery cannula 132, respectively. In one embodiment, sheath ring 125 functions to inhibit delamination of the delivery cannulas from proximal taper wall 122 of balloon 120 and, where thermally sealed to the various cannulas may reduce the spacing (on a proximal side of sheath ring 125) of the cannulas. Thus, a distal end of sheath ring 125 is placed, in one embodiment, at a point immediately proximal to where a delivery cannula will rotate, bend or plicate in response to the expansion or inflation of balloon 120. In one embodiment, sheath ring 125 is a bio-compatible material that is capable of connecting to (e.g., bonding to) a material for balloon 120 and to a material for each of the noted cannulas that it surrounds. Representatively, a body of sheath ring 125 has a length from a proximal end to a distal end on the order of 0.25 millimeters (mm) to 0.75 mm, such as 0.5 mm.

As noted above, each delivery cannula (e.g., delivery cannula 130, delivery cannula 132) plicates or bends distal to sheath ring 125 with the inflation of balloon 120. Thus, the path to be traveled by each needle (e.g., needle 134 and needle 136) includes this bend or plication. To facilitate a travel through a bend or plication region in each delivery cannula and to inhibit puncturing of the respective delivery cannula, each delivery cannula may include a deflector disposed along an interior wall. Representatively, a suitable deflector includes a ribbon of thin, generally flexible and generally resilient material (e.g., thickness on the order of about 0.0005 inches to about 0.003 inches and width on the order of about 0.005 inches and 0.015 inches). Suitable deflector materials, dimensions and connections within a catheter assembly are described in commonly-owned, U.S. patent application Ser. No. 09/746,498 (filed Dec. 21, 2000), titled "Local Drug Delivery Catheter with Retractable Needle," of Chow et al. (issued as U.S. Pat. No. 6,692,466) and U.S. patent application Ser. No. 10/749,354 (filed Dec. 31, 2003), titled "Modified Needle Catheter for Directional Orientation Delivery," of Chan, et al.

Referring again to FIG. 1, proximal portion 113 of catheter assembly 100 is intended, in one embodiment, to reside outside a patient while the remainder of catheter assembly 100 is percutaneously introduced into, for example, the cardiovascular system of a patient via a brachial, a radial or a femoral artery. In this embodiment, proximal portion 113 of catheter assembly 100 includes hub 140. Hub 140 includes needle 134 and needle 136, and inflation cannula 128. In one embodiment, relative to the materials for the various cannulas described, a housing of hub 140 is a hard or rigid polymer material, e.g., a polycarbonate or acrylonitrile butadiene styrene (ABS). A distal end of hub 140 has an opening to accommodate a proximal end of catheter body 112. Hub 140 also has a number of cavities at least partially therethrough (extending in a distal to proximal direction) to accommodate needle 134 and needle 136, and inflation cannula 128. A proximal portion of hub 140 flares to separate a spacing between the needles, and inflation cannula 128.

FIG. 1 shows a proximal end of needle 134 and needle 136 each connected (e.g., through an adhesive) to respective injection port 144 and injection port 146. In one embodiment, each injection port includes a luer fitting for conventional syringe attachment. Each injection port allows for the introduction of treatment agent 150, including but not limited to an

Apo A-I peptide, a treatment agent including an Apo A-I peptide and/or an ACAT inhibitor. It is appreciated that treatment agent **150** introduced at injection portion **144** and injection port **146** may be the same or different (e.g., a treatment agent including an Apo A-I peptide versus an ACAT inhibitor, a drug, or other cellular component). In this embodiment, inflation cannula **128** terminates at the distal end of balloon inflation port **148**.

In one embodiment, catheter assembly **100** also includes or can be configured to include an imaging assembly. Suitable imaging assemblies include ultrasonic imaging assemblies, optical imaging assemblies, such as an optical coherence tomography (OCT) assembly, magnetic resonance imaging (MRI). One embodiment of catheter assembly **100** illustrated in FIG. **1** may include an OCT imaging assembly.

OCT uses short coherent length light (typically with a coherent length of about 10 to 100 microns) to illuminate the object (e.g., blood vessel or blood vessel walls). Light reflected from a region of interest within the object is combined with a coherent reference beam. Interference occurs between the two beams only when the reference beam and reflective beam have traveled the same distance. One suitable OCT setup may be similar to ones disclosed in U.S. Pat. Nos. 5,465,147; 5,459,570; 5,321,501; 5,291,267; 5,365,125; and 5,202,745. A suitable optical assembly for use in conjunction with a catheter assembly is made with fiber optic components that, in one embodiment, can be passed through the guidewire lumen (e.g., guidewire cannula **116** of FIG. **1**).

The catheter assembly described with reference to FIG. **1** may be used to introduce an Apo A-I peptide, a treatment composition including an Apo A-I peptide and/or an ACAT inhibitor such as described above at a desired location. FIG. **2** illustrates one technique. FIG. **3** presents a block diagram of one technique. With reference to FIGS. **2** and **3** and catheter assembly **100** of FIG. **1**, in a one procedure, guidewire **118** is introduced into, for example, an arterial system of a patient (e.g., through the femoral artery) until the distal end of guidewire **118** is upstream of a narrowed lumen of the blood vessel (e.g., upstream of lesion area **285** in vessel **270**). Catheter assembly **100** is mounted on the proximal end of guidewire **118** and advanced over the guidewire **118** until catheter assembly **100** is positioned as desired. In the example shown in FIG. **2**, catheter assembly **100** is positioned so that a medial working length of balloon **120** and delivery cannula **130** are at or adjacent the narrowed lumen of vessel **270** (block **310**). Imaging techniques may be used to place catheter assembly **100**. Once balloon **120** is placed and subject to low inflation pressure, guidewire **118** is removed and replaced in one embodiment with an optical fiber for imaging (e.g., OCT) (block **320**).

In this example, vessel **270** is viewed and the lesion area is identified or a thickness of the atherosclerotic lesion is imaged (and possibly measured) (block **320**). At this point, balloon **120** is dilated as shown in FIG. **1** by, for example, delivering a fluid to balloon **120** through inflation cannula **128**. The inflation of balloon **120** causes delivery cannula **130** to move proximate to or contact the blood vessel wall at the lesion area. Needle **136** is then advanced a distance into the lesion (e.g., atherosclerotic lesion) (block **340**). A real time image may be used to advance needle **136**. Alternatively, the advancement may be based on a measurement of the blood vessel wall or lesion boundary derived from an optical image. Once in position, an Apo A-I peptide or a treatment composition including an Apo A-I peptide is introduced through needle **136** to the lesion (block **350**).

In an embodiment where an ACAT inhibitor is also introduced through catheter assembly **100**, an ACAT inhibitor may

be introduced through needle **136**. In one embodiment, needle **136** may be introduced into a wall of vessel **270** at the lesion area or beyond the vessel (e.g., to a periadventitial space). An ACAT inhibitor may then be introduced through injection port **146**.

In the above embodiment, an Apo A-I peptide, treatment composition including an Apo A-I peptide, and/or ACAT inhibitor is introduced directly into a blood vessel wall (e.g., a lesion area of a blood vessel wall). Such introduction may follow (either immediately or at some time thereafter) a percutaneous angioplasty (PTCA) by an expanding balloon. Such introduction may also precede or follow the placement of a stent adjacent a lesion area. FIG. **4** shows a coronary blood vessel (e.g., LCX **270**) having stent **410** placed adjacent lesion area **285**. In one embodiment, stent **410** may be a drug- or other treatment agent-eluting stent. For example, stent **410** may be coated with an ACAT inhibitor to permit a combination therapy of Apo A-I and an ACAT inhibitor. In this embodiment, following a placement of stent **410**, needle **136** may be advanced through openings in a cage-like structure of stent **410** into lesion area **285** for delivery of an Apo A-I peptide or a treatment composition including an Apo A-I peptide into lesion area **285**.

In the example where stent **410** is a coated stent for eluting an ACAT inhibitor, the stent may be composed of a metal, an alloy, a polymer, or a combination thereof and a treatment agent included in a stent coating or in the body of the stent. Examples of materials used to form stents include, but are not limited to, ELATINITE®, Nitinol (nickel-titanium alloy), stainless steel, tantalum, tantalum-based alloys, platinum, platinum-based alloys, and other metals and their alloys. Alternatively, stent **410** is composed of a bioabsorbable polymer or biostable polymer. A polymer or coating is “bioabsorbable” or “biodegradable” when it is capable of being completely or substantially degraded or eroded when exposed to either an in vivo environment or an in vitro environment having physical, chemical, or biological characteristics substantially similar to those of the in vivo environment within a mammal. A polymer or coating is “degradable or erodable” when it can be gradually broken down, resorbed, absorbed and eliminated by, for example, hydrolysis, enzymolysis, metabolic processes, bulk or surface erosion, and the like within a mammal. It is to be appreciated that traces of residue of polymer may remain following biodegradation. A “biostable” polymer is a polymer that is not bioabsorbable.

Suitable polymers used in embodiments of a material for a body stent **410** (i.e., the structural aspect of the stent as opposed to a coating), include, but are not limited to, hydrophobic, hydrophilic, amphiphilic, biodegradable, or a combination thereof. Examples of hydrophobic polymers include, but are not limited to, poly(ester amide), polystyrene-polyisobutylene-polystyrene block copolymer (SIS), polystyrene, and polyisobutylene. Examples of hydrophilic polymers include, but are not limited to, polymers and co-polymers of hydroxyethyl methacrylate (HEMA); poly(methyl methacrylate) (PMMA); and poly(ethylene glycol) acrylate (PEGA). Examples of biodegradable polymers include, but are not limited to, polymers having repeating units such as, for example, an α -hydroxycarboxylic acid, a cyclic diester of an α -hydroxycarboxylic acid, a dioxanone, a lactone, a cyclic carbonate, a cyclic oxalate, an epoxide, a glycol, an anhydride, a lactic acid, a glycolic acid, a glycolic acid, a lactide, a glycolide, an ethylene oxide, an ethylene glycol, or combinations thereof. In some embodiments, the biodegradable polymers include, but are not limited, to polyesters, polyhydroxyalkanoates (PHAs), poly(ester amides), amino acids, PEG and/or alcohol groups, polycaprolactones, poly (L-lactide), poly

(D,L-lactide, poly(D,L-lactide-co-PEG) block copolymers, poly(D,L-lactide-co-trimethylene carbonate), polyglycolides, poly(lactide-co-glycolide), polydioxanones, polyorthoesters, polyanhydrides, poly(glycolic acid-co-trimethylene carbonate), polyphosphoesters, polyphosphoester urethanes, poly(amino acids), polycyanoacrylates, poly(trimethylene carbonate), poly(imino carbonate), polycarbonates, polyurethanes, co-poly (ether-esters) (e.g., PEO/PLA), polyakylene oxalates, polyphosphazenes, PHA-PEG, and any derivatives, analogs, homologues, salts, copolymers and combinations thereof.

A composition including an ACAT inhibitor may be included in a stent coating on stent **410** or included in the body of stent **410** such as, for example, a biodegradable polymeric stent. The release profile of, for example, ACAT inhibitor and polymer can be controlled by tailoring the chemical composition and crystallinity of the polymer as the coating or the bioabsorbable stent material (e.g., the more crystalline, the slower the release rate).

In the embodiments described with reference to FIGS. **1-4**, a catheter assembly for introducing an Apo A-I peptides, a treatment composition including an Apo A-I peptide, and/or an ACAT inhibitor into a wall of a blood vessel (e.g., into a lesion area of the blood vessel) is described. In another embodiment, it may be desired to introduce an Apo A-I peptide, a treatment composition including an Apo A-I peptide and/or an ACAT inhibitor within a blood vessel (i.e., an intra-coronary introduction). Such technique may be used, for example, to deliver an Apo A-I synthetic peptide including an amino acid sequence in an order reverse to an order of an endogenous Apo A-I peptide and/or an Apo A-I peptide that is a chimera of helix 1 and helix 9 of Apo A-I, optionally with an amino acid sequence in reverse order. An intra-coronary introduction of the Apo A-I peptide or a treatment composition including an Apo A-I peptide will promote reverse cholesterol transport from within a lumen of a coronary vessel. Alternatively, an Apo A-I peptide or a treatment composition including an Apo A-I peptide may be introduced regionally, such as injected into an accessible artery through a needle injection.

FIG. **5** shows blood vessel **517** having catheter assembly **500** disposed therein. Catheter assembly **500** includes proximal portion **513** and distal portion **514**. Proximal portion **513** may be external to blood vessel **517** and to the patient. Representatively, catheter assembly **500** may be inserted through a femoral artery and through, for example, a guide catheter and with the aid of a guidewire to a location in the vasculature of a patient. That location may be, for example, a coronary artery. FIG. **5** shows distal portion **514** of catheter assembly **500** positioned at a treatment site within a coronary blood vessel (blood vessel **517**).

In one embodiment, catheter assembly **500** includes primary cannula **512** having a length that extends from proximal portion **513** (e.g., located external to a patient during a procedure) to connect to the proximal end or skirt of balloon **520**. Primary cannula **512** has a lumen therethrough that includes inflation cannula **528** and delivery cannula **530**. Each of the inflation cannula **528** and delivery cannula **530** extend from proximal portion **513** of catheter assembly **500** to distal portion **514**. Inflation cannula **528** has a distal end that terminates in balloon **520**. Delivery cannula **530** extends through balloon **520** (i.e., beyond a distal end or skirt of balloon **520**). In another embodiment, catheter assembly **500** does not include a balloon or inflation cannula.

Catheter assembly **500** also includes guidewire cannula **516** extending, in this embodiment, through balloon **520** to a distal end of catheter assembly **500**. Guidewire cannula **516**

has a lumen sized to accommodate a guidewire (not shown). Catheter assembly **500** may be an over-the-wire (OTW) configuration where guidewire cannula **516** extends from a proximal end (external to a patient during a procedure) to a distal end of catheter assembly **500**. In another embodiment, catheter assembly **500** is a rapid exchange (RX) type catheter assembly where only a portion of catheter assembly **500** (a distal portion including balloon **520**) is advanced over the guidewire. FIG. **5** shows an OTW type catheter assembly.

In one embodiment, catheter assembly is introduced into blood vessel **517** in a direction of blood flow, such as through a femoral artery to a location within a coronary artery. Once introduced, balloon **520** is inflated (e.g., with a suitable liquid through inflation cannula **528**) to occlude a blood vessel. Following occlusion, an Apo A-I peptide or a treatment composition including an Apo A-I peptide is introduced through delivery cannula **530**. FIG. **5** shows treatment agent **550** that may be connected to delivery port **544** and introduced into delivery cannula **530**. As noted above, in one embodiment, the delivery of treatment agent **550** will be with the flow of blood through the blood vessel. To retain a treatment agent (e.g., Apo A-I) within a location in a blood vessel for at least a minimum period of time, it may be desirable to inflate a first balloon distal to an injury site (e.g., lesion area) and inflate a second balloon proximal to the injury site, thus isolating the injury site between the two inflated balloons. The distal balloon may be part of catheter assembly **500** (e.g., a dual balloon catheter) or a part of the guidewire (e.g., a PERCUTAN SURG™ catheter assembly, commercially available from Medtronic, Inc. of Minneapolis, Minn.).

In an effort to improve the target area of an Apo A-I mimetic peptide to a treatment site, such as treatment site **285** in FIG. **2**, the treatment site may be isolated prior to delivery. FIG. **6** shows an embodiment of a catheter assembly having two balloons where one balloon is located proximal to treatment site **285** and a second balloon is located distal to treatment site **285**. A stent may optionally be placed adjacent to treatment site. FIG. **6** shows stent **605** that may be a drug-eluting stent coated with, for example, an ACAT inhibitor. FIG. **6** shows catheter assembly **600** disposed within blood vessel **100**. Catheter assembly **600** has a tandem balloon configuration including proximal balloon **625** and distal balloon **635** aligned in series at a distal portion of the catheter assembly. Catheter assembly **600** also includes primary cannula **615** having a length that extends from a proximal end of catheter assembly **600** (e.g., located external to a patient during a procedure) to connect with a proximal end or skirt of balloon **625**. Primary cannula **615** has a lumen therethrough that includes inflation cannula **630** and inflation cannula **650**. Inflation cannula **630** extends from a proximal end of catheter assembly **600** to a point within balloon **625**. Inflation cannula **630** has a lumen therethrough allowing balloon **625** to be inflated through inflation cannula **630**. In this embodiment, balloon **625** is inflated through an inflation lumen separate from the inflation lumen that inflates balloon **635**. Inflation cannula **650** has a lumen therethrough allowing fluid to be introduced in the balloon **635** to inflate the balloon. In this manner, balloon **625** and balloon **635** may be separately inflated. Each of inflation cannula **630** and inflation cannula **650** extends from, in one embodiment, the proximal end of catheter assembly **600** through a point within balloon **625** and balloon **635**, respectively.

Catheter assembly **600** also includes guidewire cannula **620** extending, in this embodiment, through each of balloon **625** and balloon **635** through a distal end of catheter assembly. Guidewire cannula **620** has a lumen therethrough sized to accommodate a guidewire. No guidewire is shown within

guidewire cannula **620**. Catheter assembly **600** may be an over the wire (OTW) configuration or a rapid exchange (RX) type catheter assembly. FIG. 6 illustrates an RX type catheter assembly.

Catheter assembly **600** also includes delivery cannula **640**. In this embodiment, delivery cannula **640** extends from a proximal end of catheter assembly **600** through a location between balloon **625** and balloon **635**. Secondary cannula **645** extends between balloon **625** and balloon **635**. A proximal portion or skirt of balloon **635** connects to a distal end of secondary cannula **645**. A distal end or skirt of balloon **625** is connected to a proximal end of secondary cannula **645**. Delivery cannula **640** terminates at opening **660** through secondary cannula **645**. In this manner, a treatment agent such as Apo A-I mimetic peptide may be introduced between balloon **625** and balloon **635** positioned between treatment site **285**.

FIG. 6 shows balloon **625** and balloon **635** each inflated to occlude a lumen of blood vessel **100** and isolate treatment site **285**. In one embodiment, each of balloon **625** and balloon **635** are inflated to a point sufficient to occlude blood vessel **100** prior to the introduction of a treatment agent. A treatment agent, such as Apo A-I mimetic peptide is then introduced through opening **660**.

In the above embodiment, separate balloons having separate inflation lumens are described. It is appreciated, however, that a single inflation lumen may be used to inflate each of balloon **625** and balloon **635**. Alternatively, in another embodiment, balloon **635** may be a guidewire balloon configuration such as a PERCUSURGTTM catheter assembly where catheter assembly **600** including only balloon **625** is inserted over a guidewire including balloon **635**.

FIG. 7 shows another embodiment of a catheter assembly. Catheter assembly **700**, in this embodiment, includes a porous balloon through which a treatment agent, such as Apo A-I mimetic peptide, may be introduced. FIG. 7 shows catheter assembly **700** disposed within blood vessel **100**. Catheter assembly **700** has a porous balloon configuration positioned at treatment site **285**. Catheter assembly **700** includes primary cannula **715** having a length that extends from a proximal end of catheter assembly **700** (e.g., located external to a patient during a procedure) to connect with a proximal end or skirt of balloon **725**. Primary cannula **715** has a lumen therethrough that includes inflation cannula **730**. Inflation cannula **730** extends from a proximal end of catheter assembly **700** to a point within balloon **725**. Inflation cannula **730** has a lumen therethrough allowing balloon **725** to be inflated through inflation cannula **730**.

Catheter assembly **700** also includes guidewire cannula **720** extending, in this embodiment, through balloon **725**. Guidewire cannula **720** has a lumen therethrough sized to accommodate a guidewire. No guidewire is shown within guidewire cannula **720**. Catheter assembly **700** may be an over-the-wire (OTW) configuration or rapid exchange (RX) type catheter assembly. FIG. 7 illustrates an OTW type catheter assembly.

Catheter assembly **700** also includes delivery cannula **740**. In this embodiment, delivery cannula **740** extends from a proximal end of catheter assembly **700** to proximal end or skirt of balloon **725**. Balloon **725** is a double layer balloon. Balloon **725** includes inner layer **7250** that is a non-porous material, such as PEBAX, Nylon or PET. Balloon **725** also includes outer layer **7255**. Outer layer **7255** is a porous material, such as extended polytetrafluoroethylene (ePTFE). In one embodiment, delivery cannula **740** is connected to between inner layer **7250** and outer layer **7255** so that a

treatment agent can be introduced between the layers and permeate through pores in balloon **725** into a lumen of blood vessel **100**.

As illustrated in FIG. 7, in one embodiment, catheter assembly **700** is inserted into blood vessel **100** so that balloon **725** is aligned with treatment site **285**. Blood vessel **100** may include stent **710** disposed adjacent treatment site **285**. Following alignment of balloon **725** of catheter assembly **700**, balloon **725** may be inflated by introducing an inflation medium (e.g., liquid through inflation cannula **730**). In one embodiment, balloon **725** is only partially inflated or has an inflated diameter less than an inner diameter of blood vessel **100** at treatment site **285**. In this manner, balloon **725** does not contact or only minimally contacts the blood vessel wall. A suitable expanded diameter of balloon **725** is on the order of 2.0 to 5.0 mm for coronary vessels. It is appreciated that the expanded diameter may be different for peripheral vasculature. Following the expansion of balloon **725**, a treatment agent, such as Apo A-I mimetic peptide is introduced into delivery cannula **740**. The treatment agent flows through delivery cannula **740** into a volume between inner layer **7250** and outer layer **7255** of balloon **725**. At a relatively low pressure (e.g., on the order of two to four atmospheres (atm)), the treatment agent then permeates through the porous of outer layer **7255** into blood vessel **100**.

FIG. 8 shows another embodiment of a catheter assembly suitable for introducing a treatment agent into a blood vessel. FIG. 8 shows catheter assembly **800** disposed within blood vessel **100**. Blood vessel **100** may also include stent **810** disposed adjacent treatment site **285**. Catheter assembly **800** includes primary cannula **815** having a length that extends from a proximal end of catheter assembly **800** (e.g., located external to a patient during a procedure) to connect with a proximal and/or skirt of balloon **825**. Balloon **825**, in this embodiment, is located at a position aligned with treatment site **285** in blood vessel **100**.

Disposed within primary cannula **815** is guidewire cannula **820** and inflation cannula **830**. Guidewire cannula **820** extends from a proximal end of catheter assembly **800** through balloon **825**. A distal end or skirt of balloon **825** is connected to a distal portion of guidewire cannula **820**.

Inflation cannula **830** extends from a proximal end of catheter assembly **800** to a point within balloon **825**. In one embodiment, balloon **825** is made of a porous material such as ePTFE. A suitable pore size for an ePTFE balloon material is on the order of one μm to 60 μm . The porosity of ePTFE material can be controlled to accommodate a treatment agent flow rate or particle size by changing a microstructure of an ePTFE tape used to form a balloon, for example, by wrapping around a mandrel. Alternatively, pore size may be controlled by controlling the compaction process of the balloon, or by creating pores (e.g., micropores) using a laser.

ePTFE as a balloon material is a relatively soft material and tends to be more flexible and conformable with tortuous coronary vessels than conventional balloons. ePTFE also does not need to be folded which will lower its profile and allow for smooth deliverability to distal lesions and the ability to provide therapy to targeted or regional sites post angioplasty and/or stent deployment.

A size of balloon **825** can also vary. A suitable balloon diameter is, for example, in the range of two to five mm. A balloon length may be on the order of eight to 60 mm. A suitable balloon profile range is, for example, approximately 0.030 inches to 0.040 inches.

In one embodiment, a porous balloon may be masked in certain areas along its working length to enable more targeted delivery of a treatment agent. In another embodiment, a

sheath may be advanced over a porous balloon (or the balloon withdrawn into a sheath) to allow tailoring of a treatment agent distribution. In another embodiment, a sheath may have a window for targeting delivery of the treatment agent through a porous balloon. In another embodiment, a liner inside a porous balloon may be used to target preferential treatment agent delivery. For example, the liner may have a window through which a treatment agent is delivered, e.g., on one side of a liner for delivery to one side of a vessel wall. This type of configuration may be used to address eccentric lesions.

In an alternative embodiment, rather than using a porous material like ePTFE for forming a porous balloon (e.g., balloon **825** in FIG. **8**), a conventional balloon material such as PEBAX, Nylon or PET may be used that has tens or hundreds of micropores around its circumference for treatment agent diffusion. A suitable pore size may range, for example, from approximately five to 100 microns. Pores may be created by mechanical means or by laser perforation. Pore distribution along a balloon surface may be inhomogeneous to tailor distribution of treatment agent delivery.

According to any of the embodiments described with reference to FIG. **8** and the accompanying text, a treatment agent such as Apo A-I mimetic peptide may be introduced through the inflation cannula (e.g., inflation cannula **830**) to expand

the balloon (e.g., balloon **825**). In the example of a balloon of a porous material, such as balloon **825**, the treatment agent will expand balloon **825** and at relatively low pressure (e.g., 2-4 atm) diffuse through pores in the porous balloon material to treatment site **280** within a lumen of blood vessel **100**. FIG. **8** shows treatment agent **880** diffusing through balloon **825** into a lumen of blood vessel **100**. Since balloon **825** is positioned at treatment site **285**, treatment agent **880** is diffused at or adjacent (e.g., proximal or distal) to treatment site **285**.

The above techniques relate generally to the delivery of a treatment agent such as Apo A-I mimetic peptide through a percutaneous method into a blood vessel or beyond a blood vessel. Other techniques for delivering a treatment agent include direct injection into the pericardium or laparoscopic introduction such as used in bypass surgery or valve repair to a target in the periaortic or myocardium. Surgical delivery techniques are also suitable and include subxiphoid, periaortic (e.g., at the time of a coronary artery bypass graft procedure) or other procedure.

In the preceding detailed description, reference is made to specific embodiments thereof. It will, however, be evident that various modifications and changes may be made thereto without departing from the broader spirit and scope of the following claims. The specification and drawings are, accordingly, to be regarded in an illustrative rather than a restrictive sense.

 SEQUENCE LISTING

<160> NUMBER OF SEQ ID NOS: 10

<210> SEQ ID NO 1

<211> LENGTH: 18

<212> TYPE: PRT

<213> ORGANISM: Artificial Sequence

<220> FEATURE:

<223> OTHER INFORMATION: Description of Artificial Sequence: Synthetic peptide

<400> SEQUENCE: 1

Asp Trp Phe Lys Ala Phe Tyr Asp Lys Val Ala Glu Lys Phe Lys Glu
 1 5 10 15

Ala Phe

<210> SEQ ID NO 2

<211> LENGTH: 18

<212> TYPE: PRT

<213> ORGANISM: Artificial Sequence

<220> FEATURE:

<223> OTHER INFORMATION: Description of Artificial Sequence: Synthetic peptide

<400> SEQUENCE: 2

Asp Trp Leu Lys Ala Phe Tyr Asp Lys Val Ala Glu Lys Leu Lys Glu
 1 5 10 15

Ala Phe

<210> SEQ ID NO 3

<211> LENGTH: 34

<212> TYPE: PRT

<213> ORGANISM: Artificial Sequence

<220> FEATURE:

<223> OTHER INFORMATION: Description of Artificial Sequence: Synthetic peptide

-continued

<400> SEQUENCE: 3

Pro Ala Leu Glu Asp Leu Arg Gln Gly Leu Leu Pro Val Leu Glu Ser
 1 5 10 15

Phe Lys Val Phe Leu Ser Ala Leu Glu Glu Tyr Thr Lys Lys Leu Asn
 20 25 30

Thr Gln

<210> SEQ ID NO 4

<211> LENGTH: 18

<212> TYPE: PRT

<213> ORGANISM: Artificial Sequence

<220> FEATURE:

<223> OTHER INFORMATION: Description of Artificial Sequence: Synthetic peptide

<220> FEATURE:

<223> OTHER INFORMATION: n-term acetylation

<220> FEATURE:

<223> OTHER INFORMATION: c-term amidation

<400> SEQUENCE: 4

Asp Trp Phe Lys Ala Phe Tyr Asp Lys Val Ala Glu Lys Phe Lys Glu
 1 5 10 15

Ala Phe

<210> SEQ ID NO 5

<211> LENGTH: 34

<212> TYPE: PRT

<213> ORGANISM: Artificial Sequence

<220> FEATURE:

<223> OTHER INFORMATION: Description of Artificial Sequence: Synthetic peptide

<220> FEATURE:

<223> OTHER INFORMATION: n-term acetylation

<220> FEATURE:

<223> OTHER INFORMATION: c-term amidation

<400> SEQUENCE: 5

Pro Ala Leu Glu Asp Leu Arg Gln Gly Leu Leu Pro Val Leu Glu Ser
 1 5 10 15

Phe Lys Val Phe Leu Ser Ala Leu Glu Glu Tyr Thr Lys Lys Leu Asn
 20 25 30

Thr Gln

<210> SEQ ID NO 6

<211> LENGTH: 18

<212> TYPE: PRT

<213> ORGANISM: Artificial Sequence

<220> FEATURE:

<223> OTHER INFORMATION: Description of Artificial Sequence: Synthetic peptide

<220> FEATURE:

<223> OTHER INFORMATION: n-term acetylation

<220> FEATURE:

<223> OTHER INFORMATION: c-term amidation

<400> SEQUENCE: 6

Phe Ala Glu Lys Phe Lys Glu Ala Val Lys Asp Tyr Phe Ala Lys Phe
 1 5 10 15

Trp Asp

<210> SEQ ID NO 7

<211> LENGTH: 18

<212> TYPE: PRT

<213> ORGANISM: Artificial Sequence

-continued

<220> FEATURE:
 <223> OTHER INFORMATION: Description of Artificial Sequence: Synthetic peptide
 <220> FEATURE:
 <223> OTHER INFORMATION: n-term acetylation
 <220> FEATURE:
 <223> OTHER INFORMATION: c-term amidation
 <400> SEQUENCE: 7

Phe Ala Glu Lys Leu Lys Glu Ala Val Lys Asp Tyr Phe Ala Lys Leu
 1 5 10 15

Trp Asp

<210> SEQ ID NO 8
 <211> LENGTH: 33
 <212> TYPE: PRT
 <213> ORGANISM: Artificial Sequence
 <220> FEATURE:
 <223> OTHER INFORMATION: Description of Artificial Sequence: Synthetic peptide
 <220> FEATURE:
 <223> OTHER INFORMATION: n-term acetylation
 <220> FEATURE:
 <223> OTHER INFORMATION: c-term amidation
 <400> SEQUENCE: 8

Asn Leu Lys Lys Thr Tyr Glu Glu Leu Ala Ser Leu Phe Ser Val Lys
 1 5 10 15

Phe Ser Glu Leu Val Pro Leu Leu Gly Gln Arg Leu Asp Glu Leu Ala
 20 25 30

Pro

<210> SEQ ID NO 9
 <211> LENGTH: 33
 <212> TYPE: PRT
 <213> ORGANISM: Artificial Sequence
 <220> FEATURE:
 <223> OTHER INFORMATION: Description of Artificial Sequence: Synthetic peptide
 <220> FEATURE:
 <223> OTHER INFORMATION: n-term acetylation
 <220> FEATURE:
 <223> OTHER INFORMATION: c-term amidation
 <400> SEQUENCE: 9

Leu Lys Leu Leu Asp Asn Trp Asp Ser Val Thr Ser Thr Phe Ser Lys
 1 5 10 15

Leu Arg Glu Gln Leu Gly Pro Ala Leu Glu Asp Leu Arg Gln Gly Leu
 20 25 30

Leu

<210> SEQ ID NO 10
 <211> LENGTH: 33
 <212> TYPE: PRT
 <213> ORGANISM: Artificial Sequence
 <220> FEATURE:
 <223> OTHER INFORMATION: Description of Artificial Sequence: Synthetic peptide
 <220> FEATURE:
 <223> OTHER INFORMATION: n-term acetylation
 <220> FEATURE:
 <223> OTHER INFORMATION: c-term amidation

-continued

<400> SEQUENCE: 10

Pro Ala Leu Glu Asp Leu Arg Gln Gly Leu Leu Pro Lys Leu Leu Asp
 1 5 10 15

Asn Trp Asp Ser Val Thr Ser Thr Phe Ser Lys Leu Arg Glu Gln Leu
 20 25 30

Gly

What is claimed is:

1. A method comprising:

advancing a delivery device through a lumen of a blood vessel to a treatment region within the blood vessel; and introducing an apolipoprotein A-1 (Apo A-I) mimetic peptide with an amino acid sequence selected from the group consisting of SEQ ID NO: 1, SEQ ID NO: 2, SEQ ID NO: 3, SEQ ID NO: 4, SEQ ID NO: 5, SEQ ID NO: 6, SEQ ID NO: 7, SEQ ID NO: 8, SEQ ID NO: 9 and SEQ ID NO: 10.

2. The method of claim 1, further comprising, after advancing the delivery device, isolating the treatment region by inflating at least two inflatable member components of the delivery device.

3. The method of claim 1 wherein the mimetic peptide introduced is in the form of a phospholipid complex.

4. The method of claim 1 wherein the treatment region of the blood vessel comprises a stenotic region.

5. The method of claim 1, further comprising, introducing an acyl-CoA:cholesterol acyltransferase (ACAT) inhibitor.

6. The method of claim 5 wherein the introduction of the mimetic peptide and the introduction of the ACAT inhibitor are simultaneous.

7. The method of claim 5 wherein the introduction of the peptide mimetic and the introduction of the ACAT inhibitor are sequential.

8. The method of claim 1, further comprising placing a stent coated with an ACAT inhibitor in the blood vessel.

* * * * *