



US007980657B2

(12) **United States Patent**  
**Silverbrook et al.**

(10) **Patent No.:** **US 7,980,657 B2**  
(45) **Date of Patent:** **Jul. 19, 2011**

(54) **PRINthead ASSEMBLY WITH AIR  
EXPULSION ARRANGEMENT**

(75) Inventors: **Kia Silverbrook**, Balmain (AU); **Tobin  
Allen King**, Balmain (AU)

(73) Assignee: **Silverbrook Research Pty Ltd**,  
Balmain, New South Wales (AU)

(\* ) Notice: Subject to any disclaimer, the term of this  
patent is extended or adjusted under 35  
U.S.C. 154(b) by 0 days.

(21) Appl. No.: **12/711,884**

(22) Filed: **Feb. 24, 2010**

(65) **Prior Publication Data**  
US 2010/0149250 A1 Jun. 17, 2010

**Related U.S. Application Data**

(63) Continuation of application No. 12/422,889, filed on  
Apr. 13, 2009, now Pat. No. 7,677,699, which is a  
continuation of application No. 11/635,485, filed on  
Dec. 8, 2006, now Pat. No. 7,524,027, which is a  
continuation of application No. 11/450,440, filed on  
Jun. 12, 2006, now Pat. No. 7,156,492, which is a  
continuation of application No. 11/250,450, filed on  
Oct. 17, 2005, now Pat. No. 7,066,573, which is a  
continuation of application No. 10/728,922, filed on  
Dec. 8, 2003, now Pat. No. 6,997,545, which is a  
continuation of application No. 10/102,700, filed on  
Mar. 22, 2002, now Pat. No. 6,692,113.

(30) **Foreign Application Priority Data**

Mar. 27, 2001 (AU) ..... PR3996

(51) **Int. Cl.**  
**B41J 2/165** (2006.01)

(52) **U.S. Cl.** ..... 347/22; 347/25; 347/49; 347/54

(58) **Field of Classification Search** ..... 347/12,  
347/13, 30, 40, 42, 49, 50, 54, 63, 65, 67,  
347/22, 25, 34  
See application file for complete search history.

(56) **References Cited**

**U.S. PATENT DOCUMENTS**

4,528,575 A 7/1985 Matsuda et al.  
(Continued)

**FOREIGN PATENT DOCUMENTS**

WO WO 01/02172 A 1/2001  
(Continued)

*Primary Examiner* — Juanita D Stephens

(57) **ABSTRACT**

A printhead assembly includes an elongate channel member of a metal alloy; a flexible elongate fluid carrier positioned on a floor of the channel member, the fluid carrier defining a plurality of passages longitudinally extending along a length of the fluid carrier, the fluid carrier further defining a repeated pattern of holes on an external surface thereof, the holes providing fluid communication from outside the fluid carrier to respective passages of the fluid carrier; and a series of printhead modules mounted to the external surface of the fluid carrier, each printhead module including an upper micro-molding and a lower micro-molding, the lower micro-molding having an air inlet slot in fluid communication with one of the plurality of passages via a hole of the repeated pattern of holes at one end and a series of alternating air inlets and outlets on the upper micro-molding at an opposite end. Each repeated pattern of holes diagonally spans a width of the fluid carrier, and the repeated pattern of holes together span a length of the fluid carrier. The alternating air inlets and outlets divert air from the air inlet slot to the printhead modules to facilitate cleaning of debris from the printhead modules.

**14 Claims, 19 Drawing Sheets**

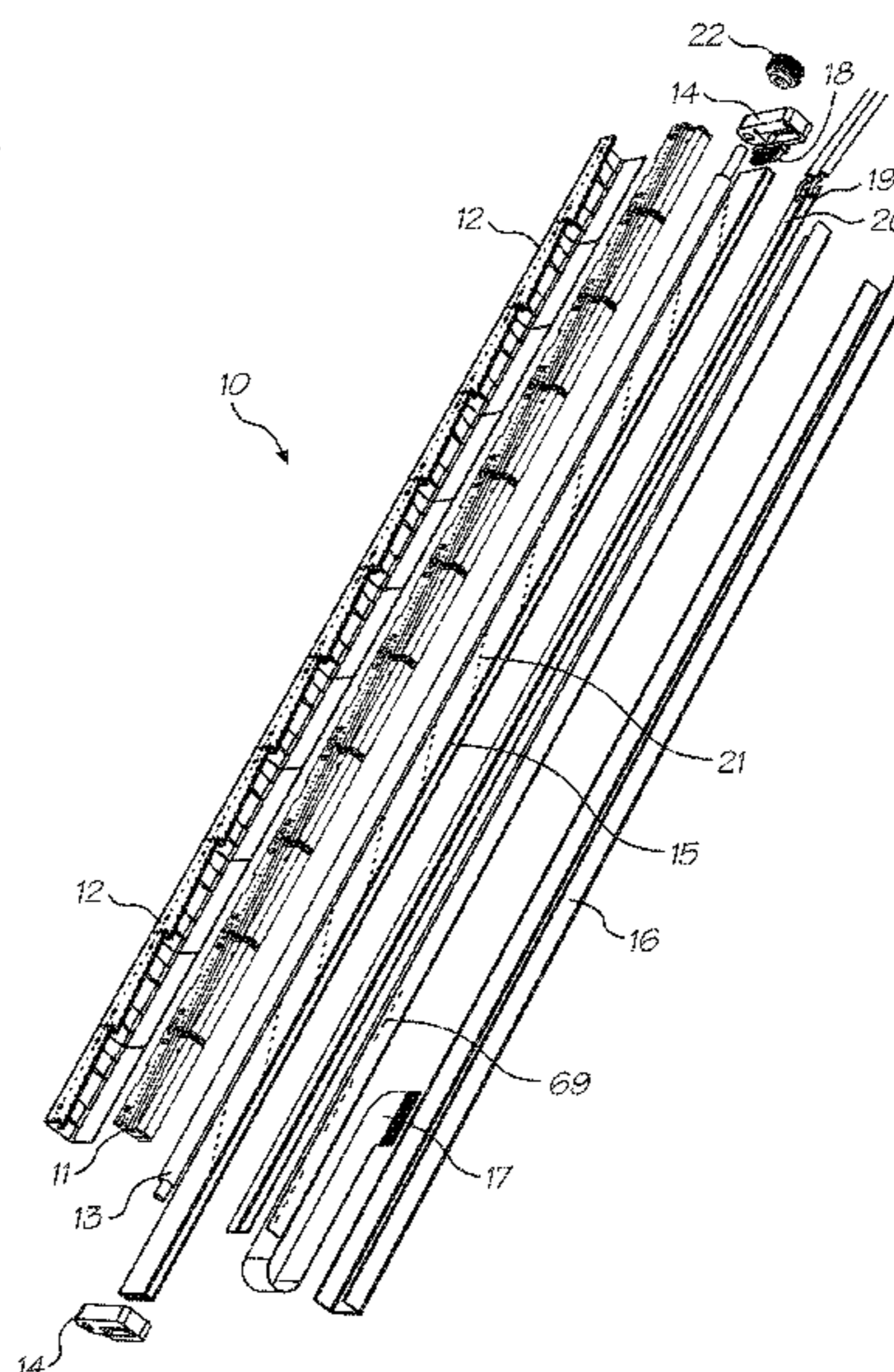
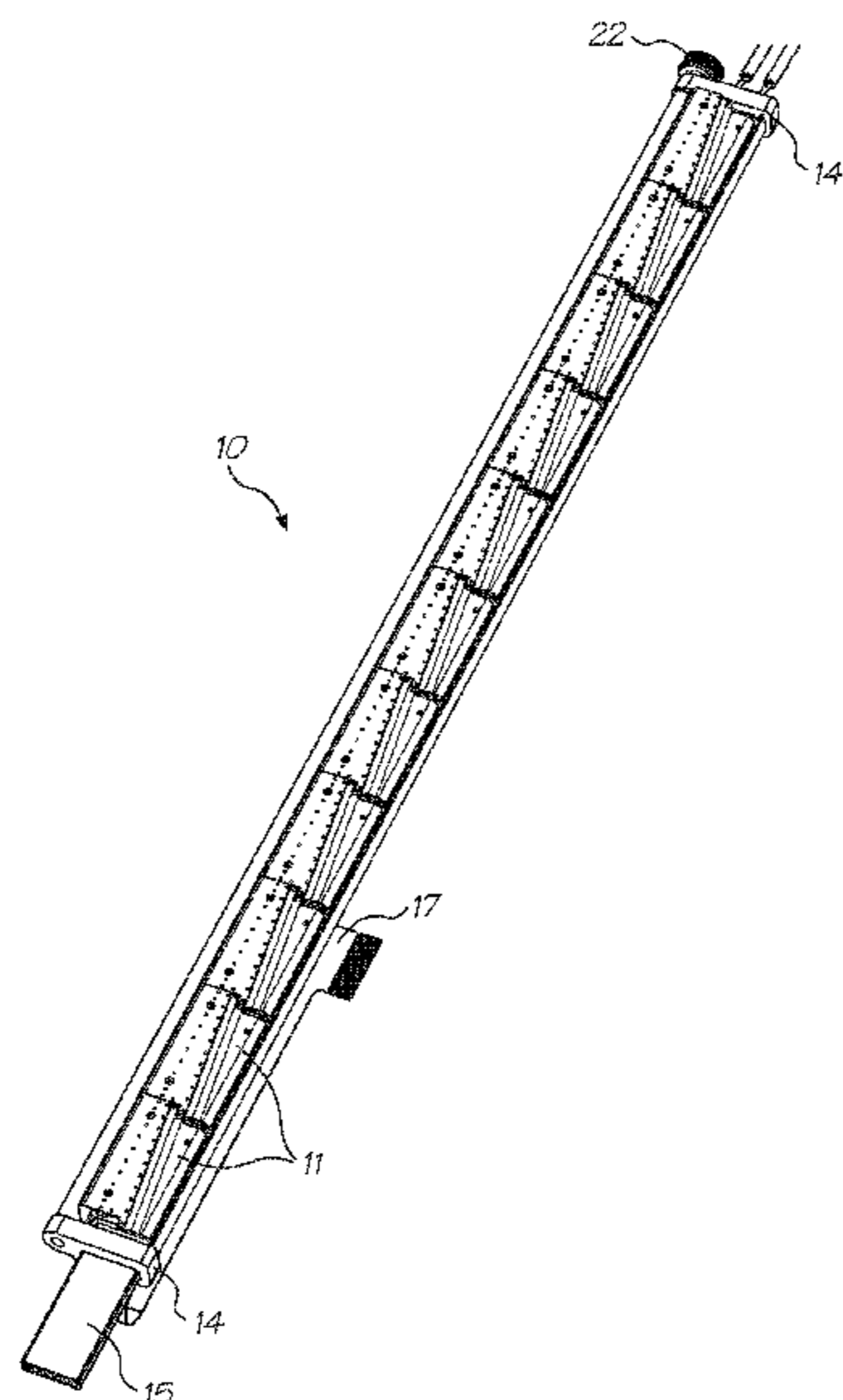

# US 7,980,657 B2

Page 2

---

## U.S. PATENT DOCUMENTS

5,869,595 A 2/1999 Fuller et al.  
5,992,982 A 11/1999 Suzuki  
6,151,049 A 11/2000 Karita et al.  
6,315,384 B1 11/2001 Ramaswami et al.  
6,341,845 B1 1/2002 Scheffelln et al.  
6,488,355 B2 12/2002 Nakamura et al.  
6,655,786 B1 12/2003 Foote et al.  
6,824,083 B2 11/2004 Okuda et al.

7,066,573 B2 6/2006 Silverbrook et al.  
7,380,924 B2 6/2008 Silverbrook et al.  
7,677,699 B2 \* 3/2010 Silverbrook et al. .... 347/49  
7,794,065 B2 9/2010 Silverbrook et al.

## FOREIGN PATENT DOCUMENTS

WO WO 01/42022 A 6/2001

\* cited by examiner

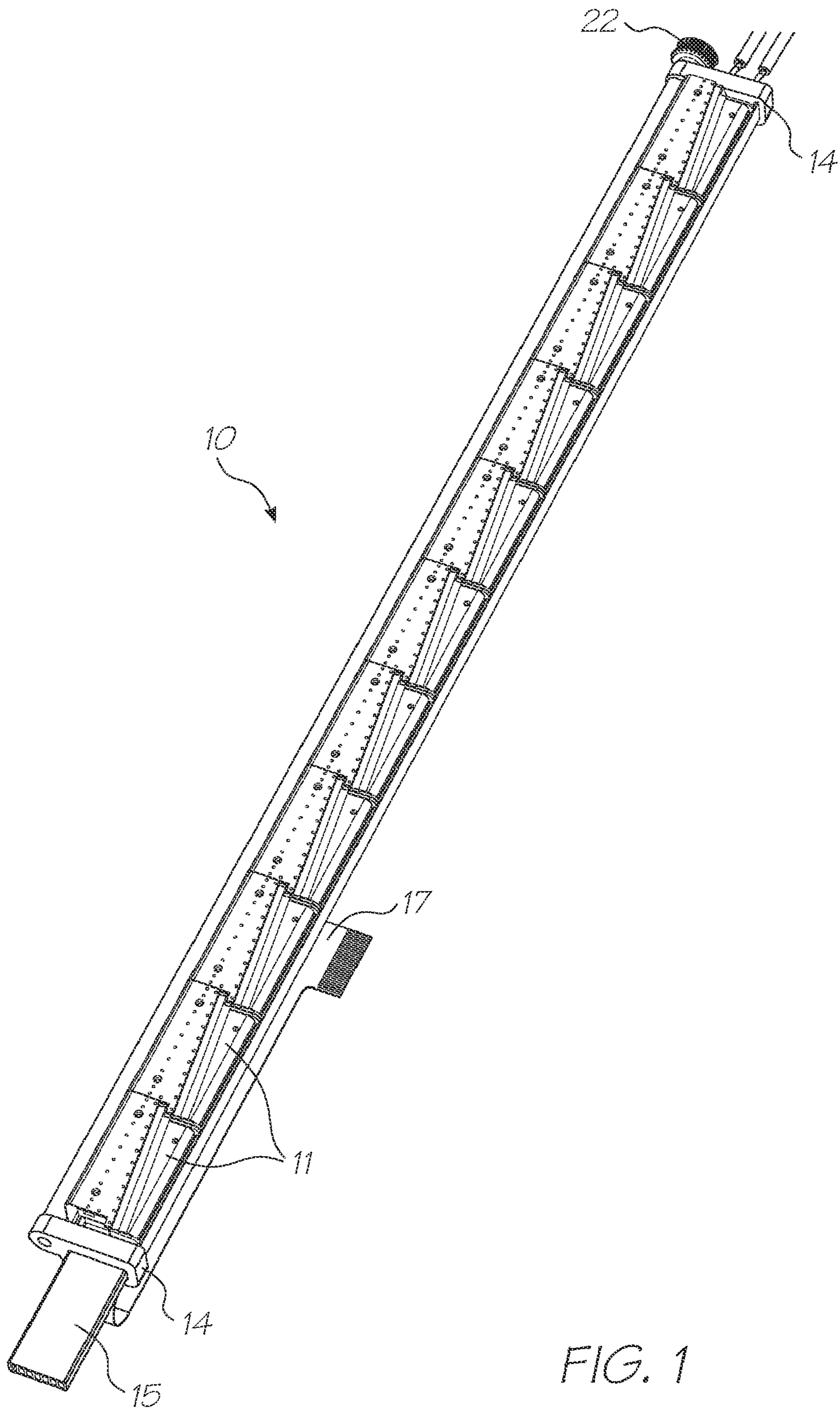

FIG. 1

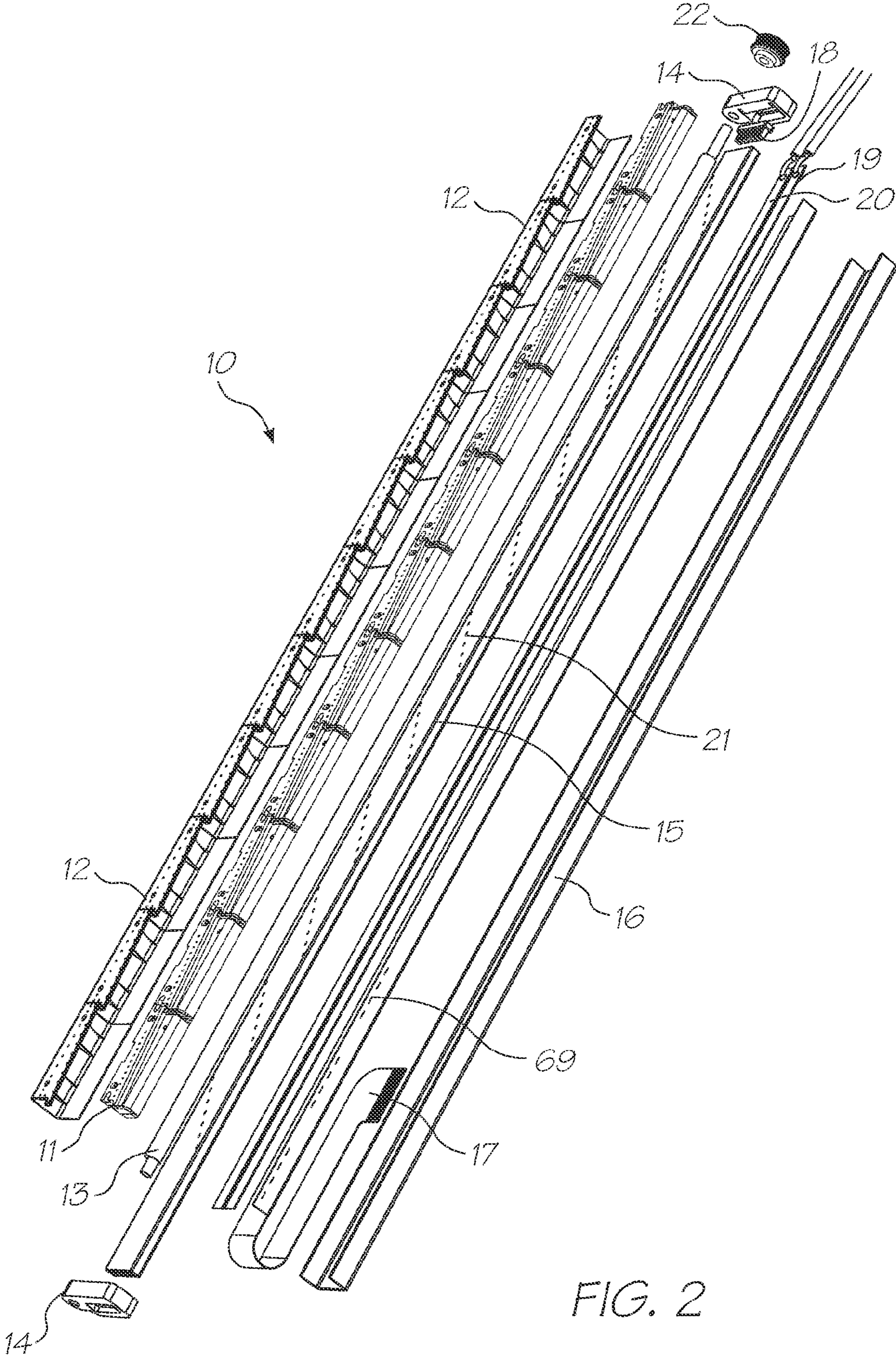

FIG. 2

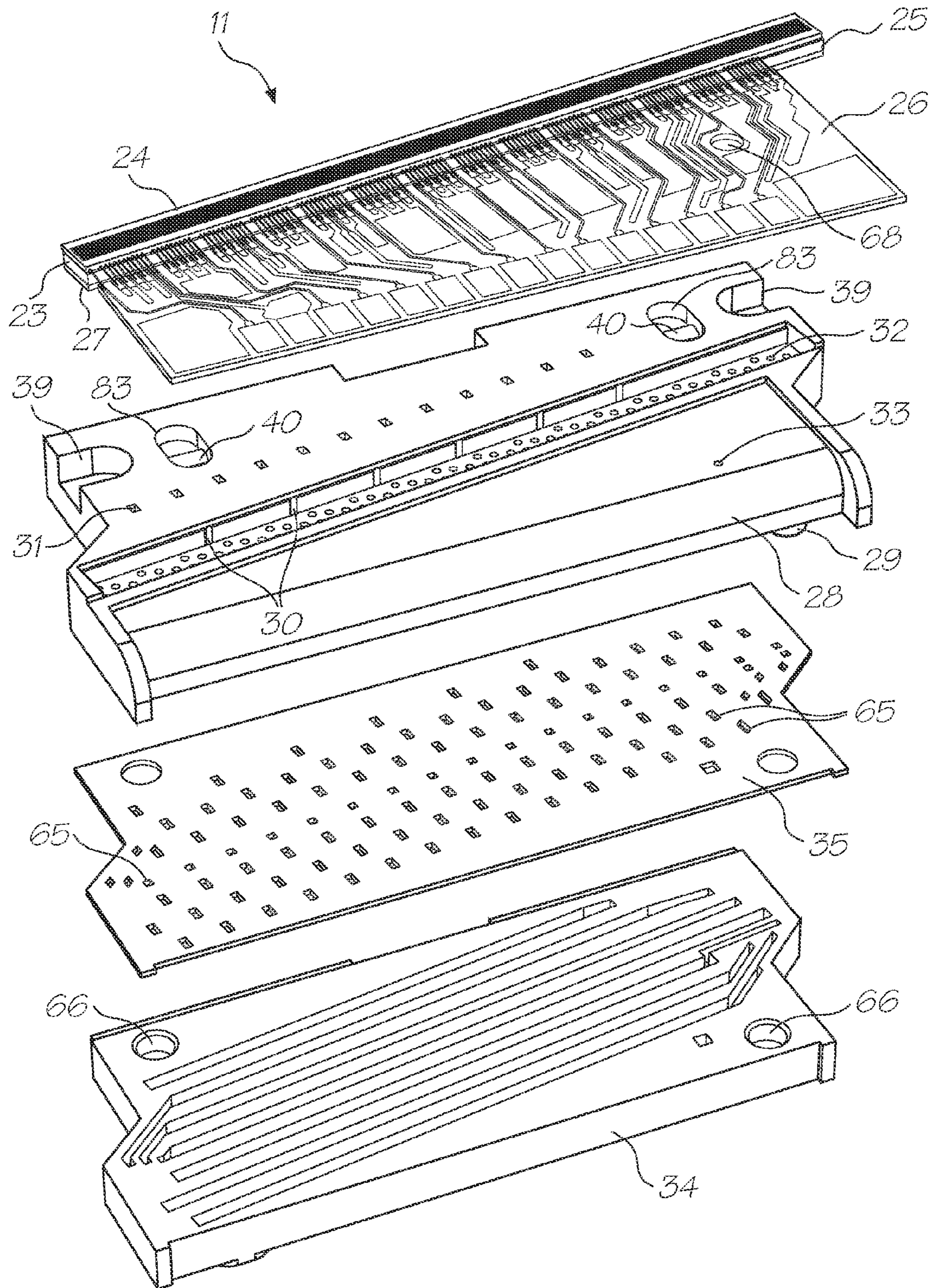

FIG. 3

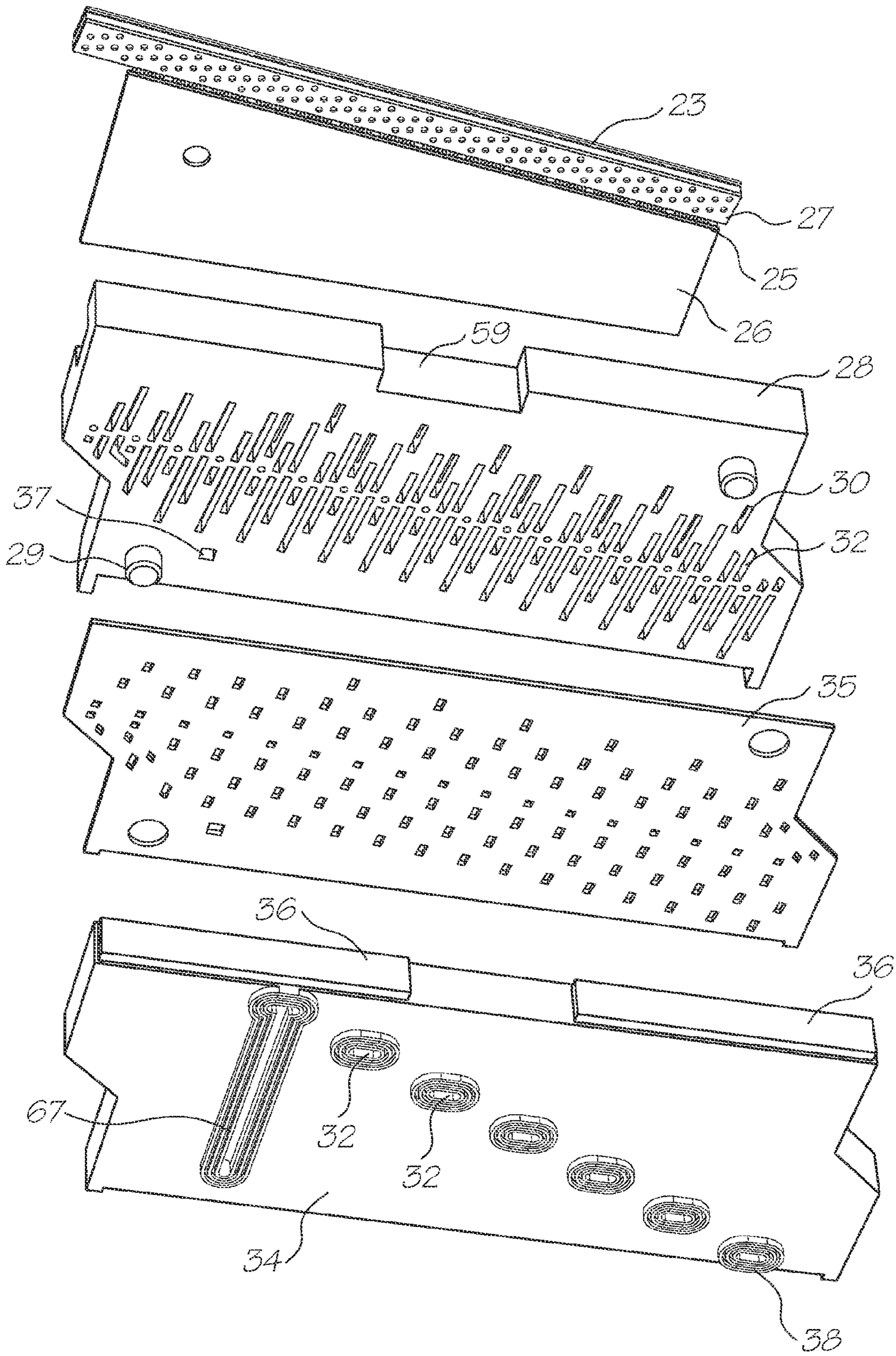

FIG. 3A

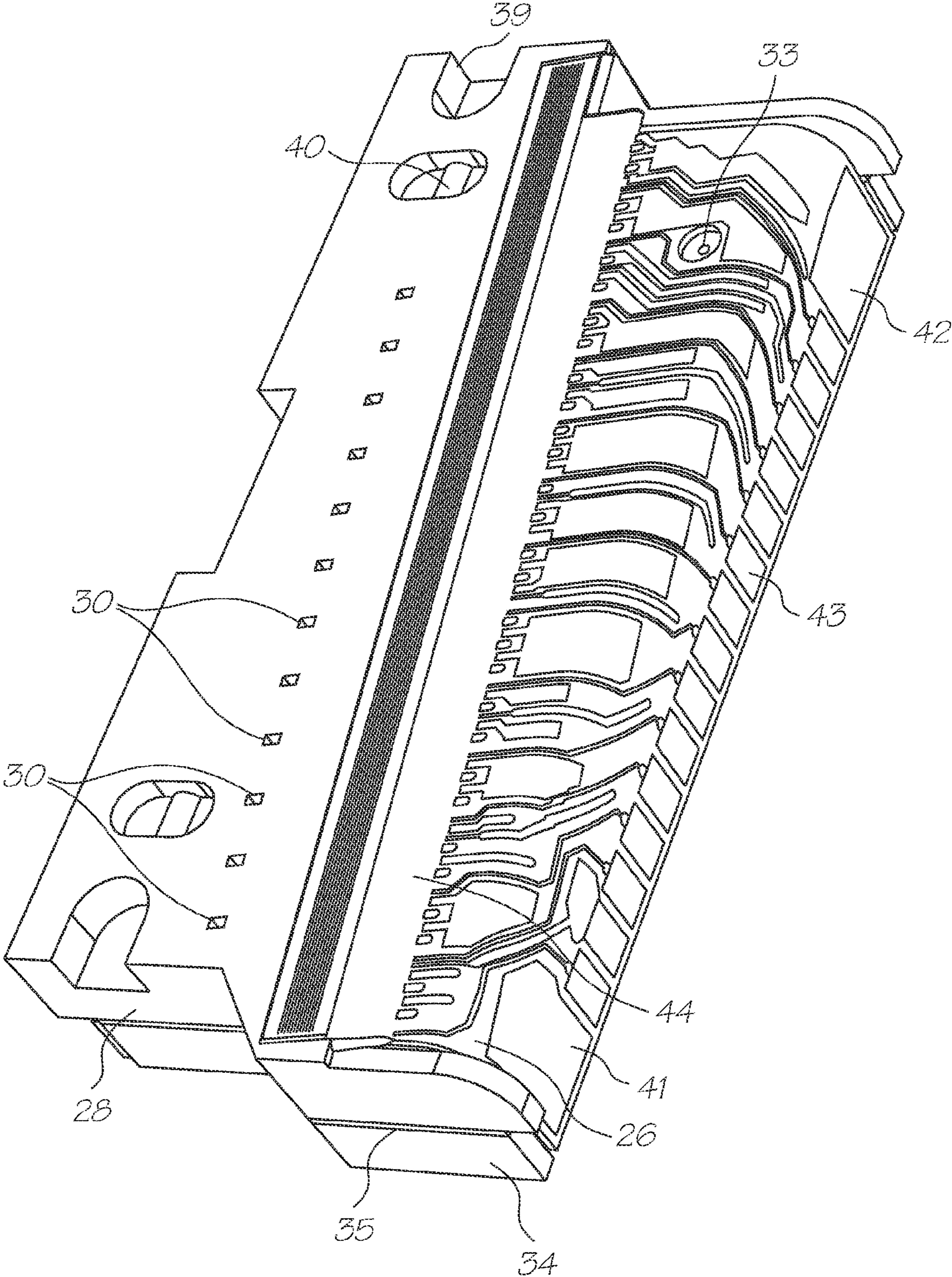

FIG. 4

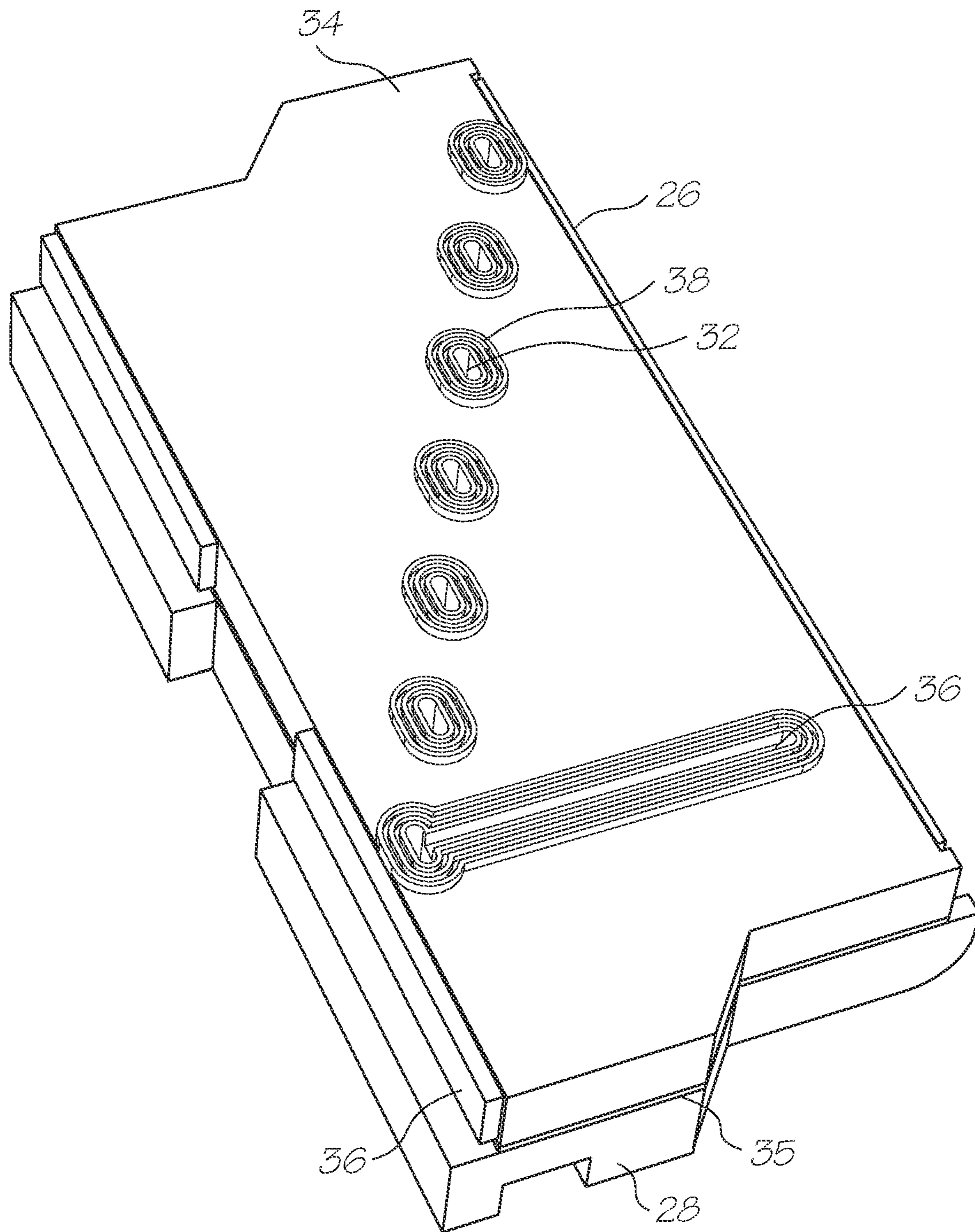

FIG. 5



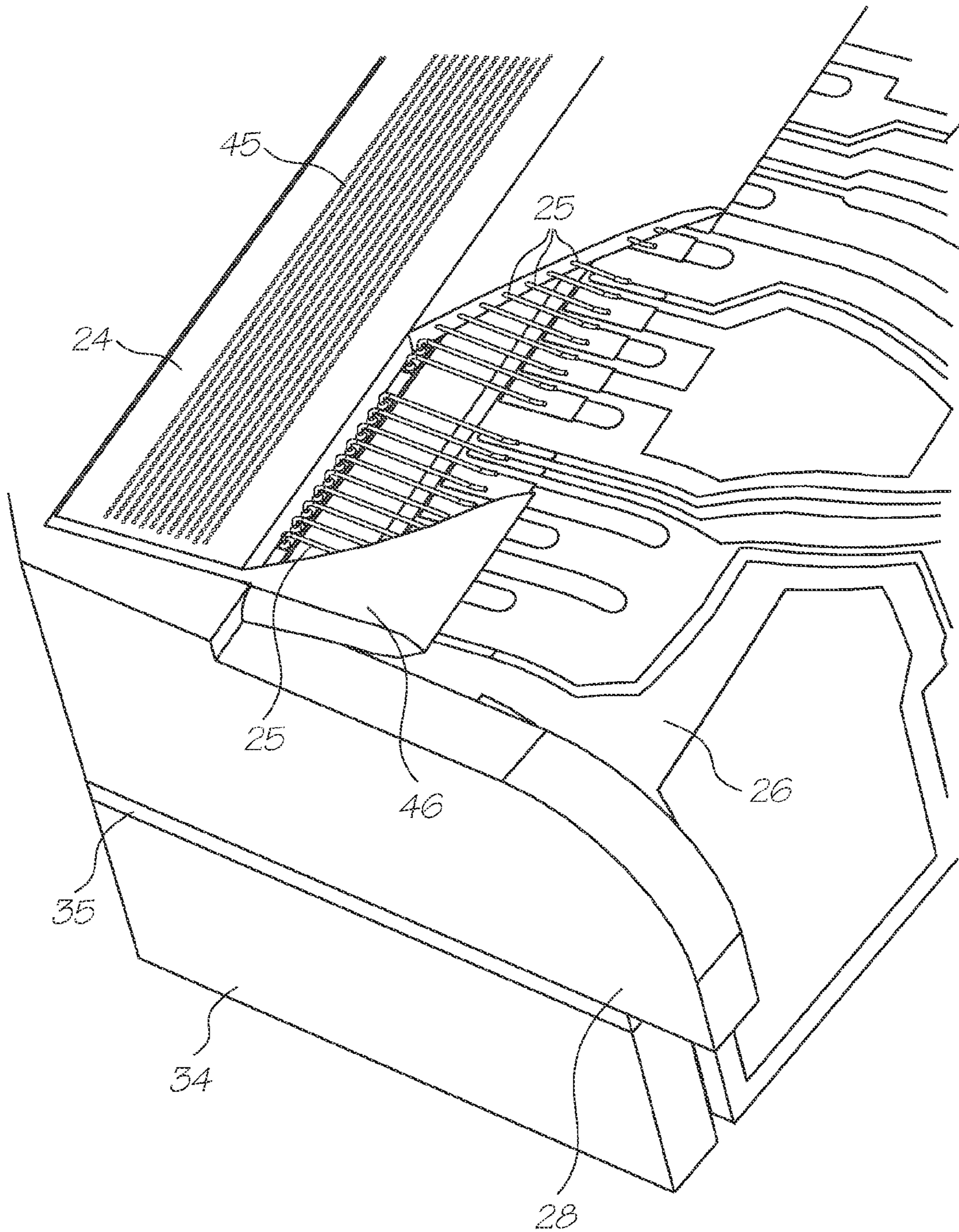

FIG. 6

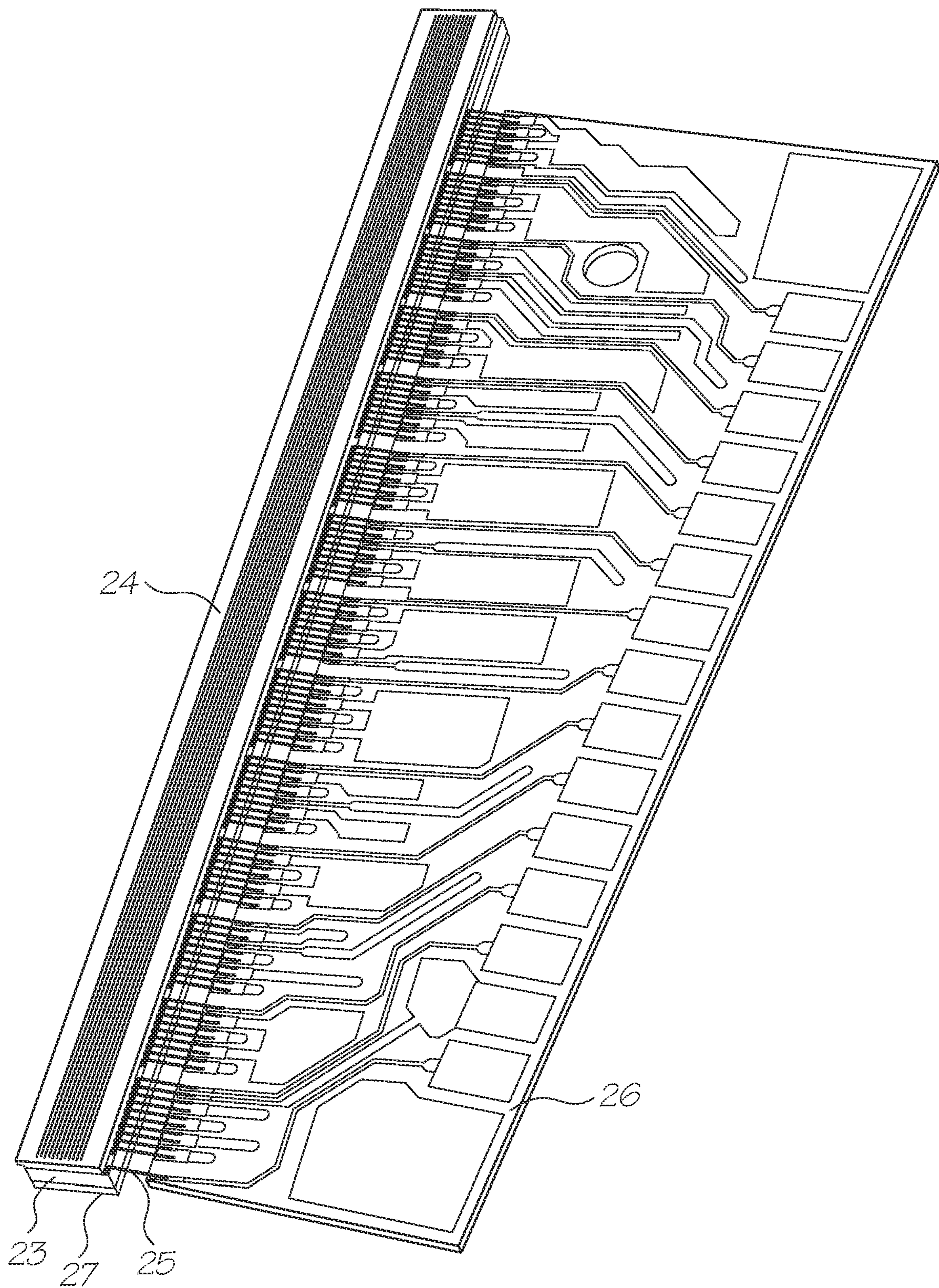

FIG. 7

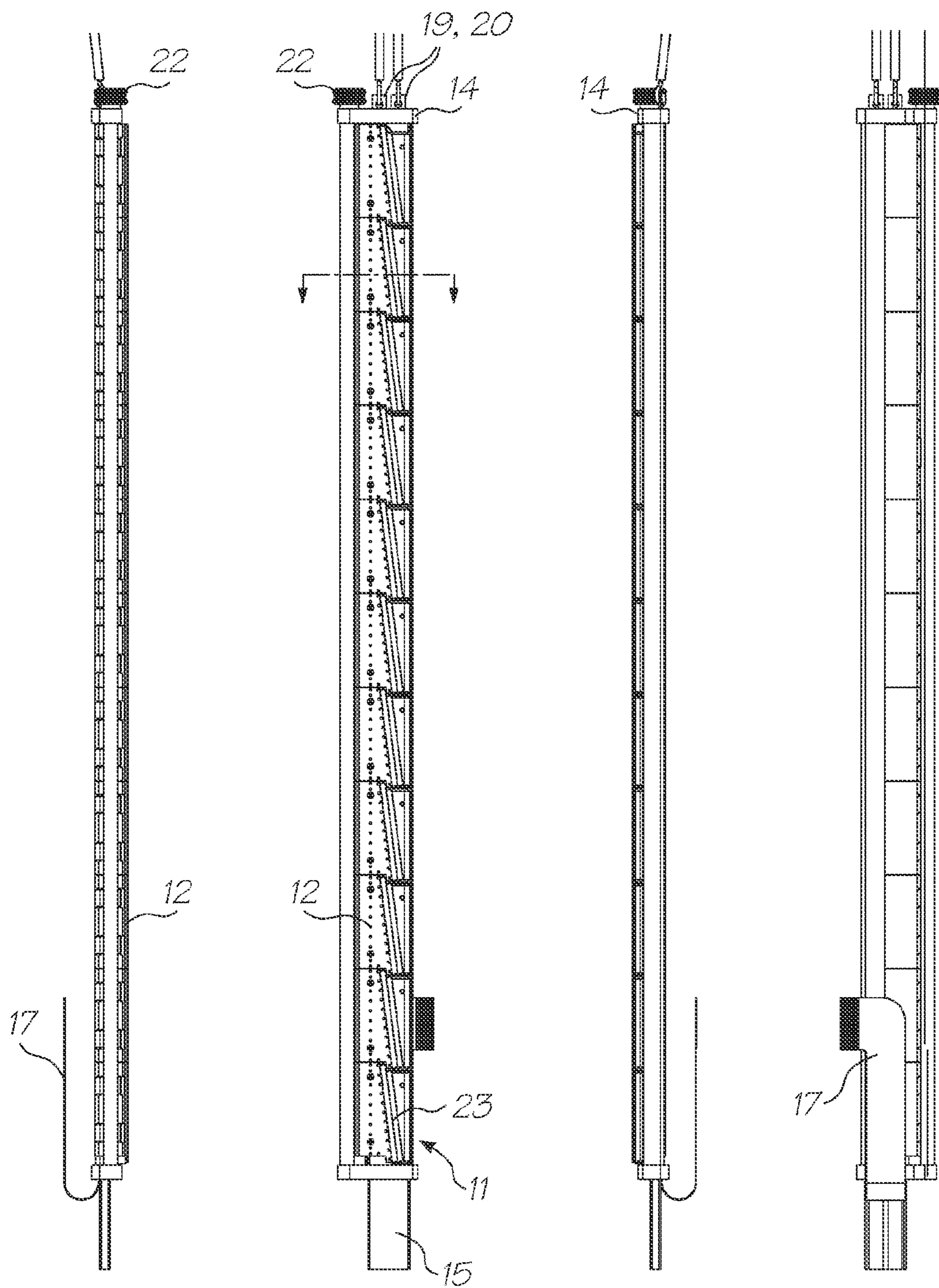

FIG. 8A

FIG. 8B

FIG. 8C

FIG. 8D

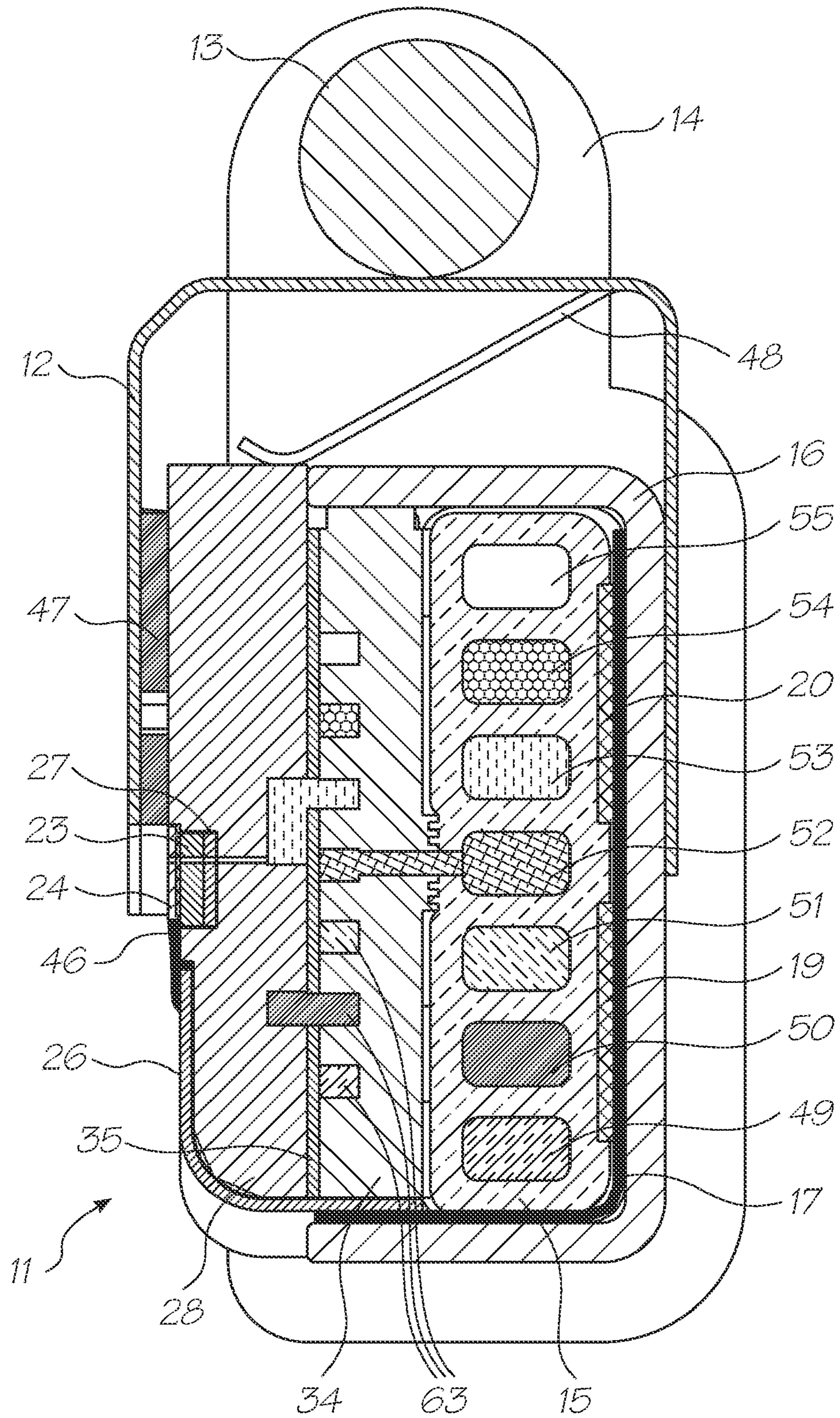

FIG. 9

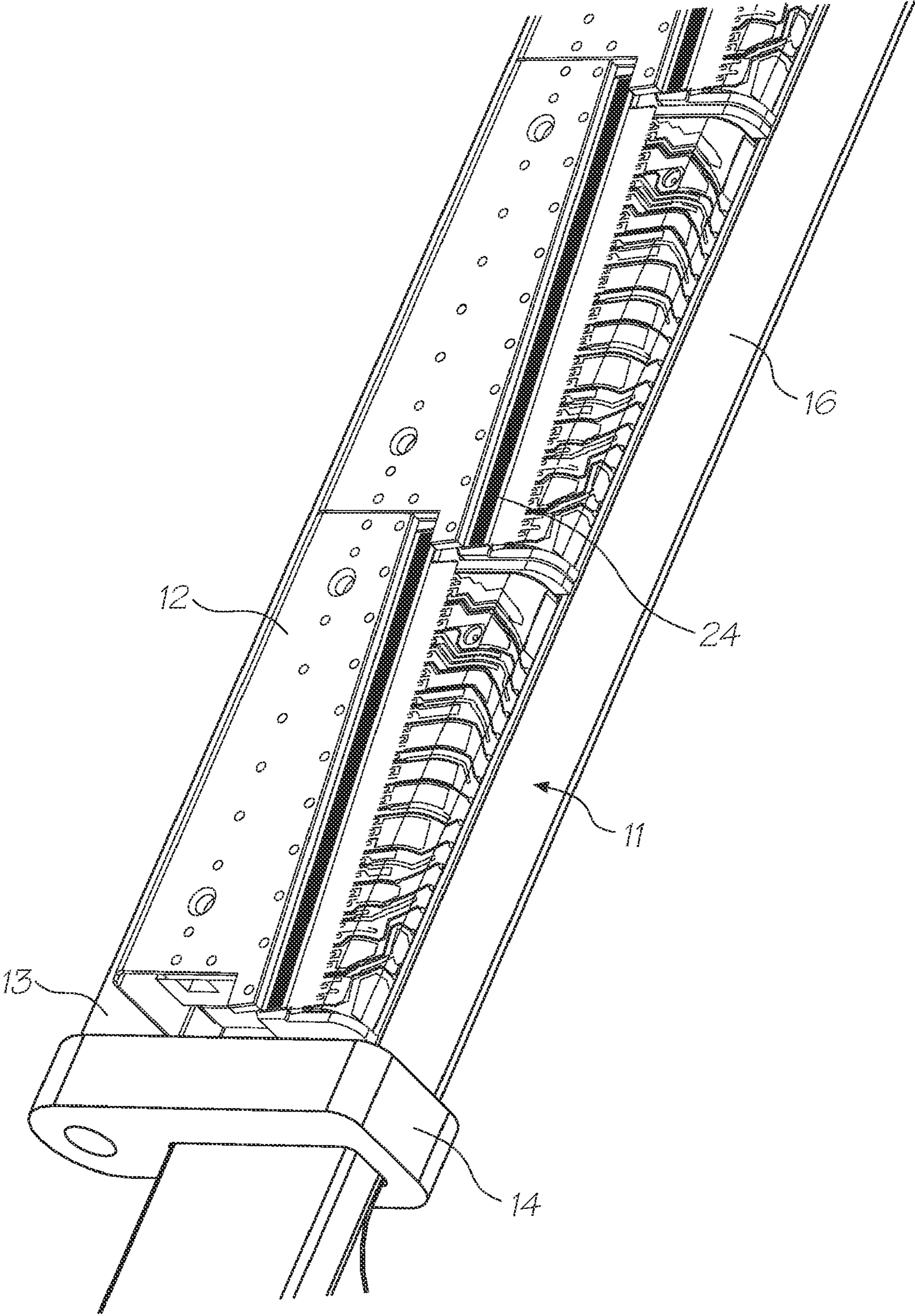

FIG. 10

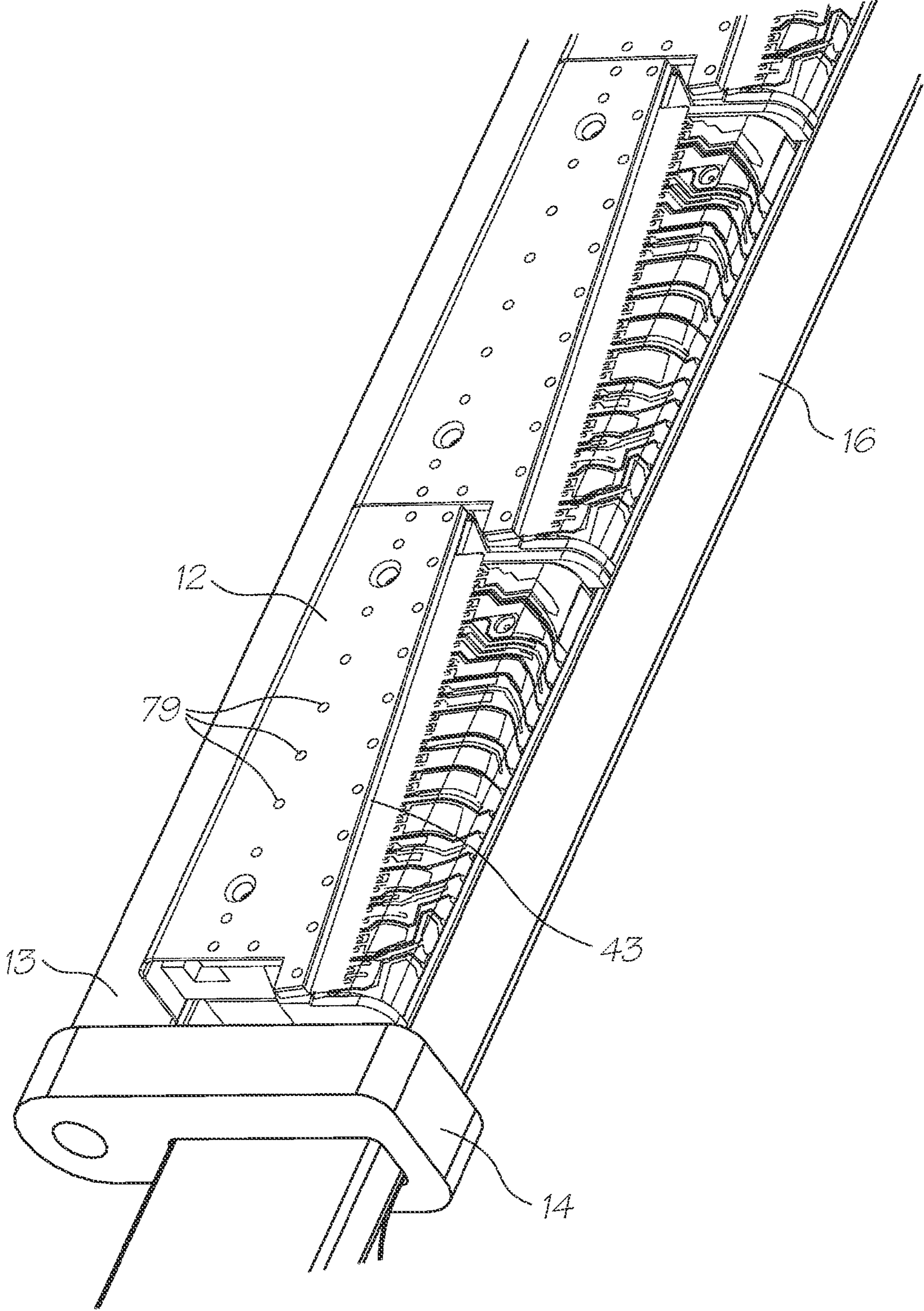

FIG. 11

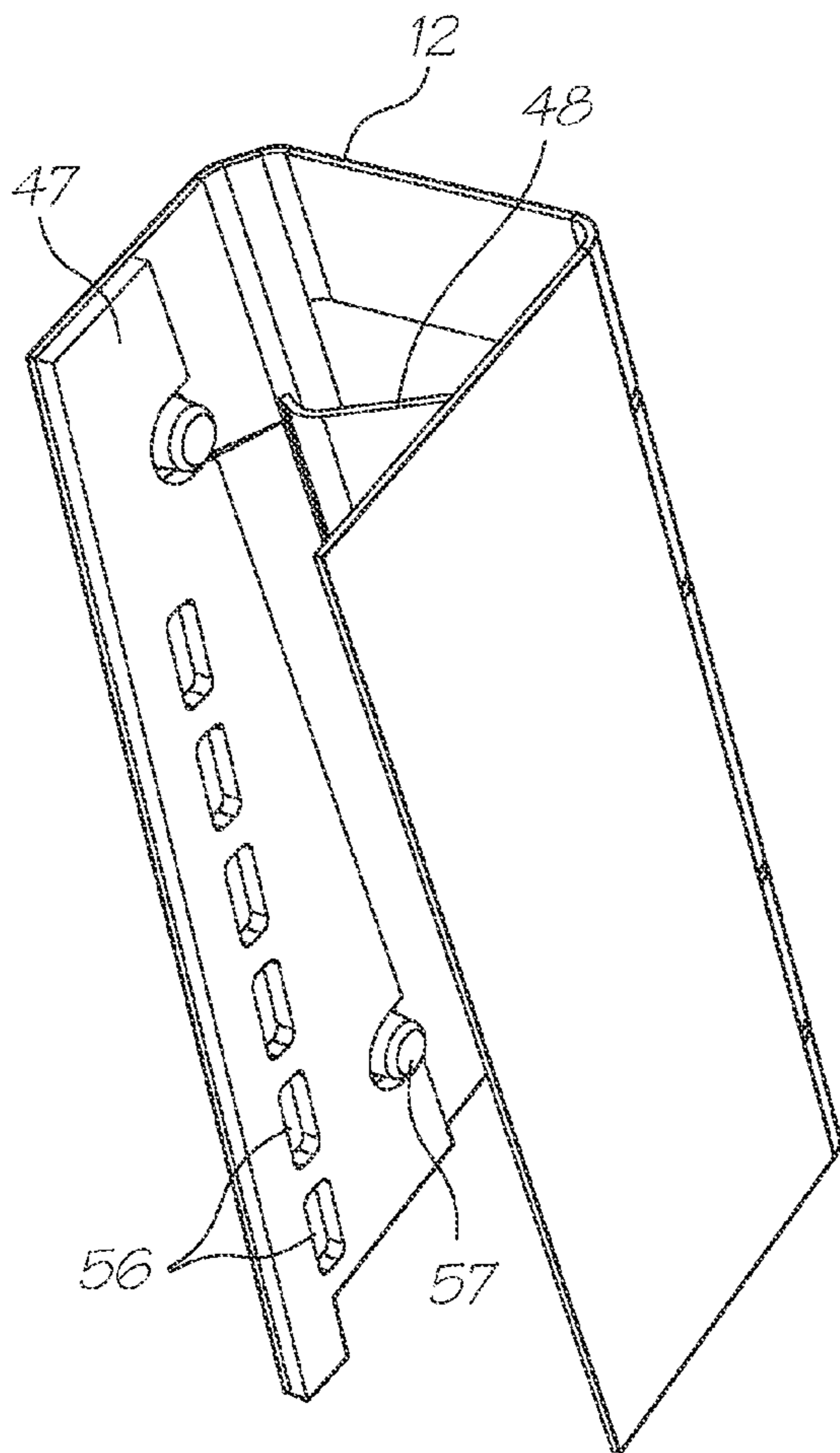

FIG. 12A

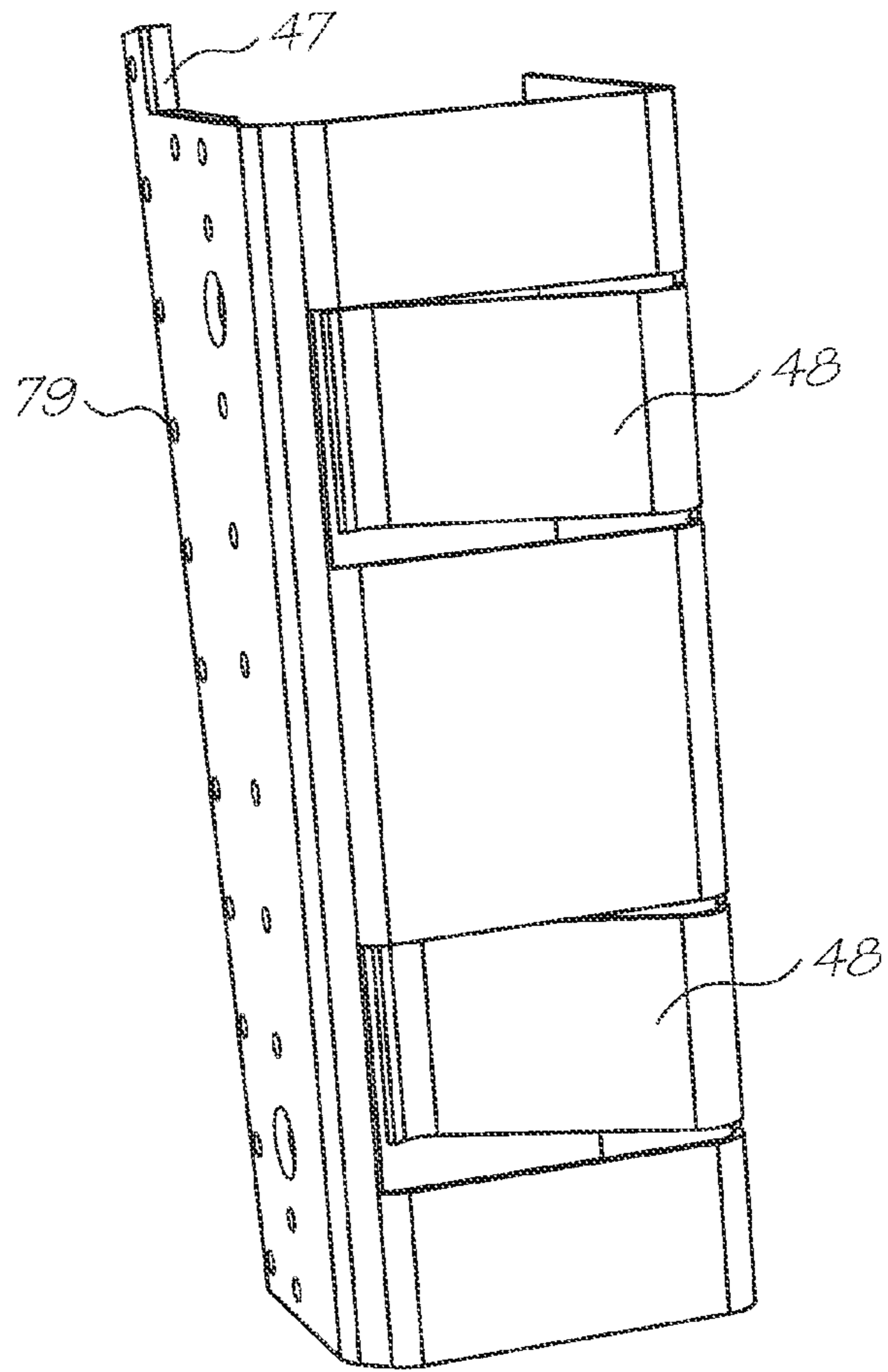

FIG. 12B

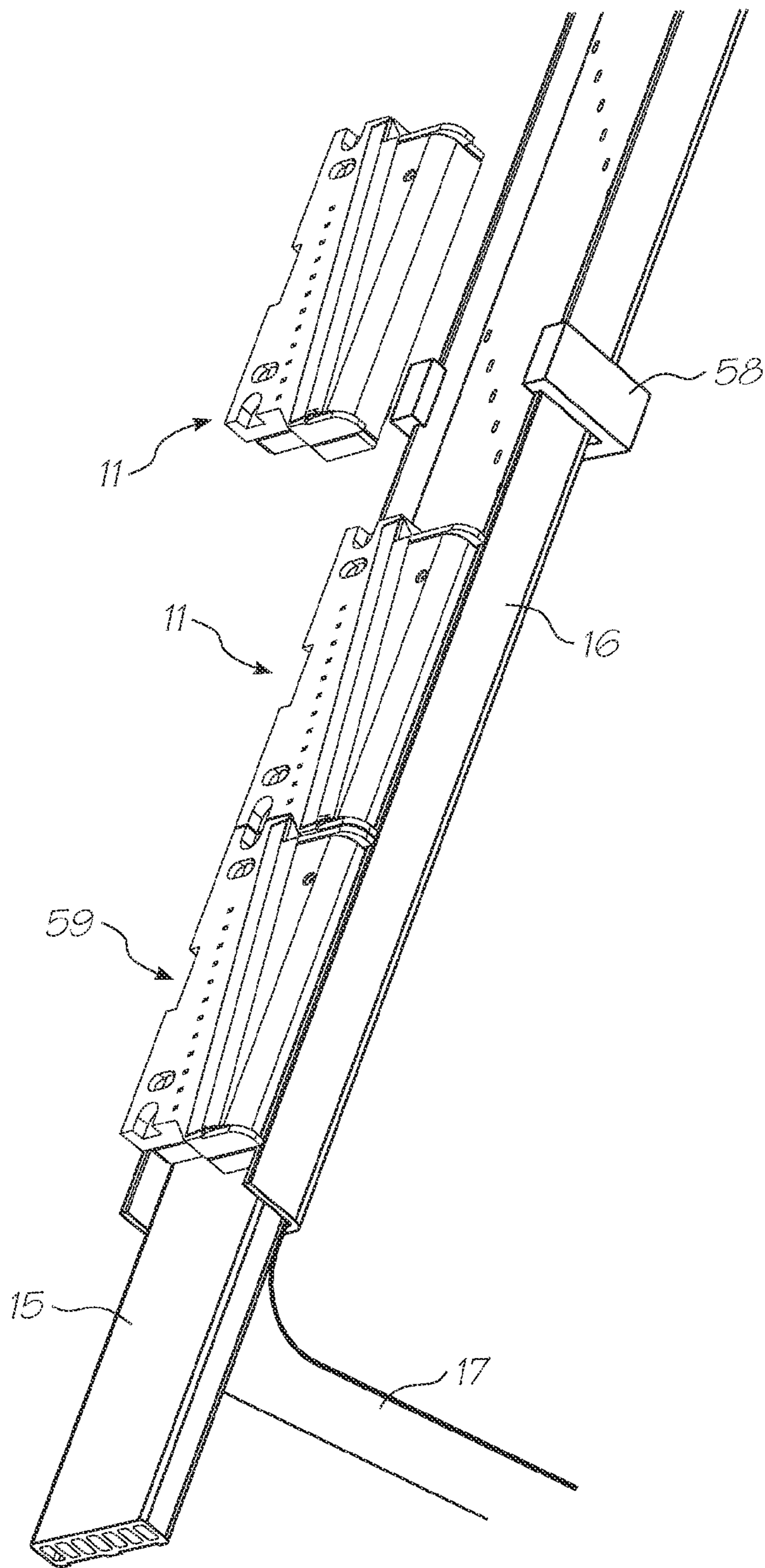

FIG. 13



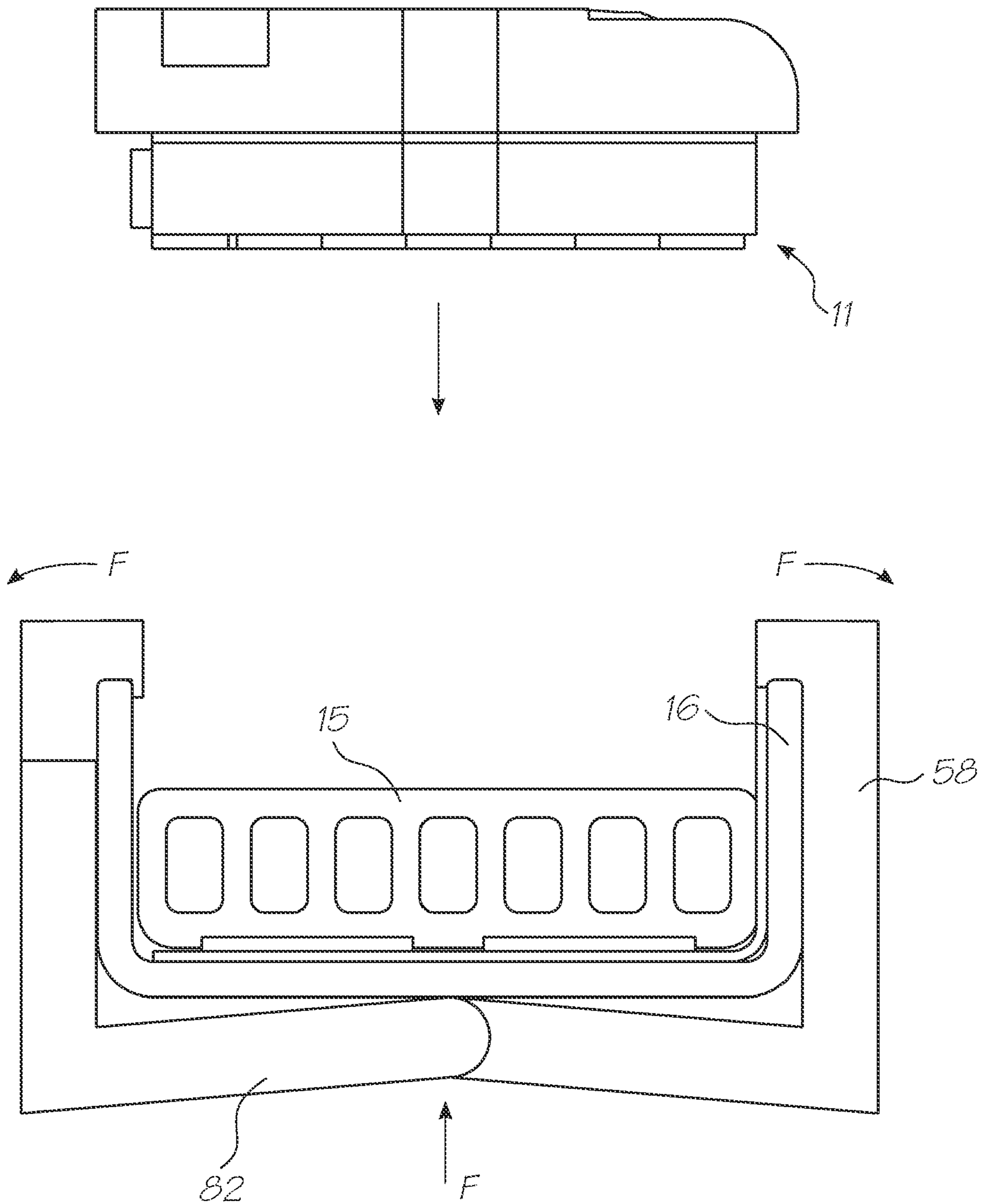

FIG. 14

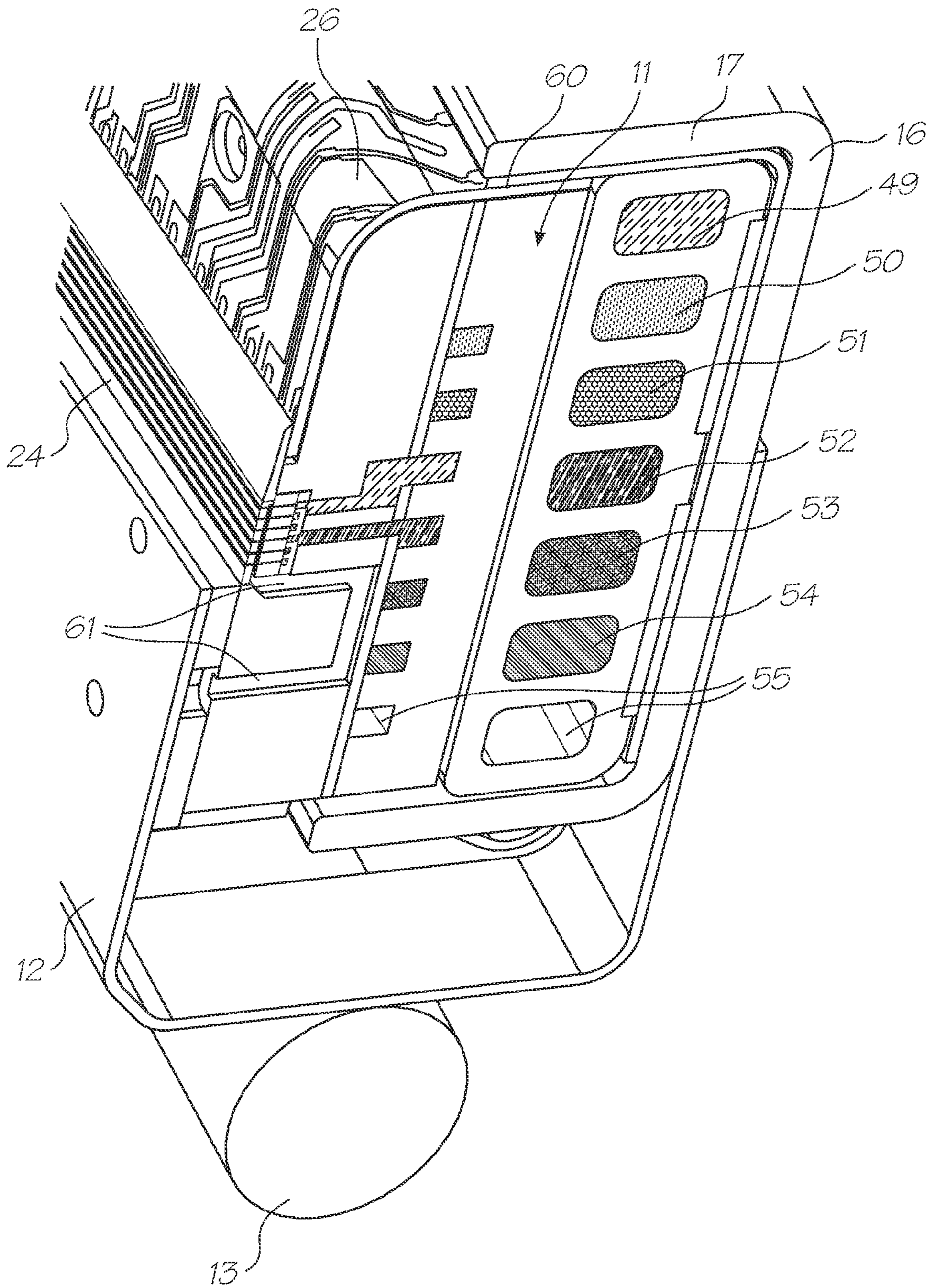

FIG. 15

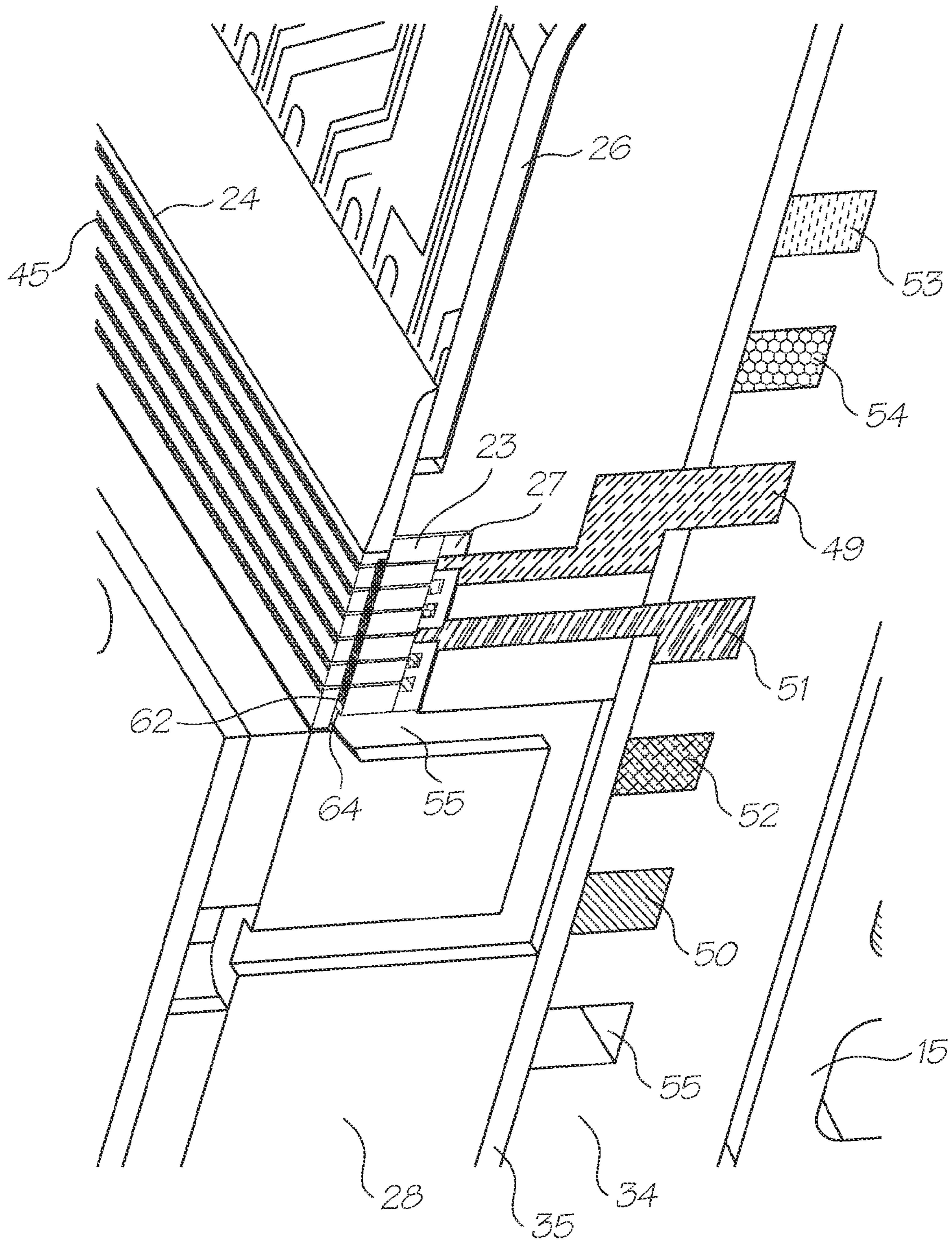

FIG. 16

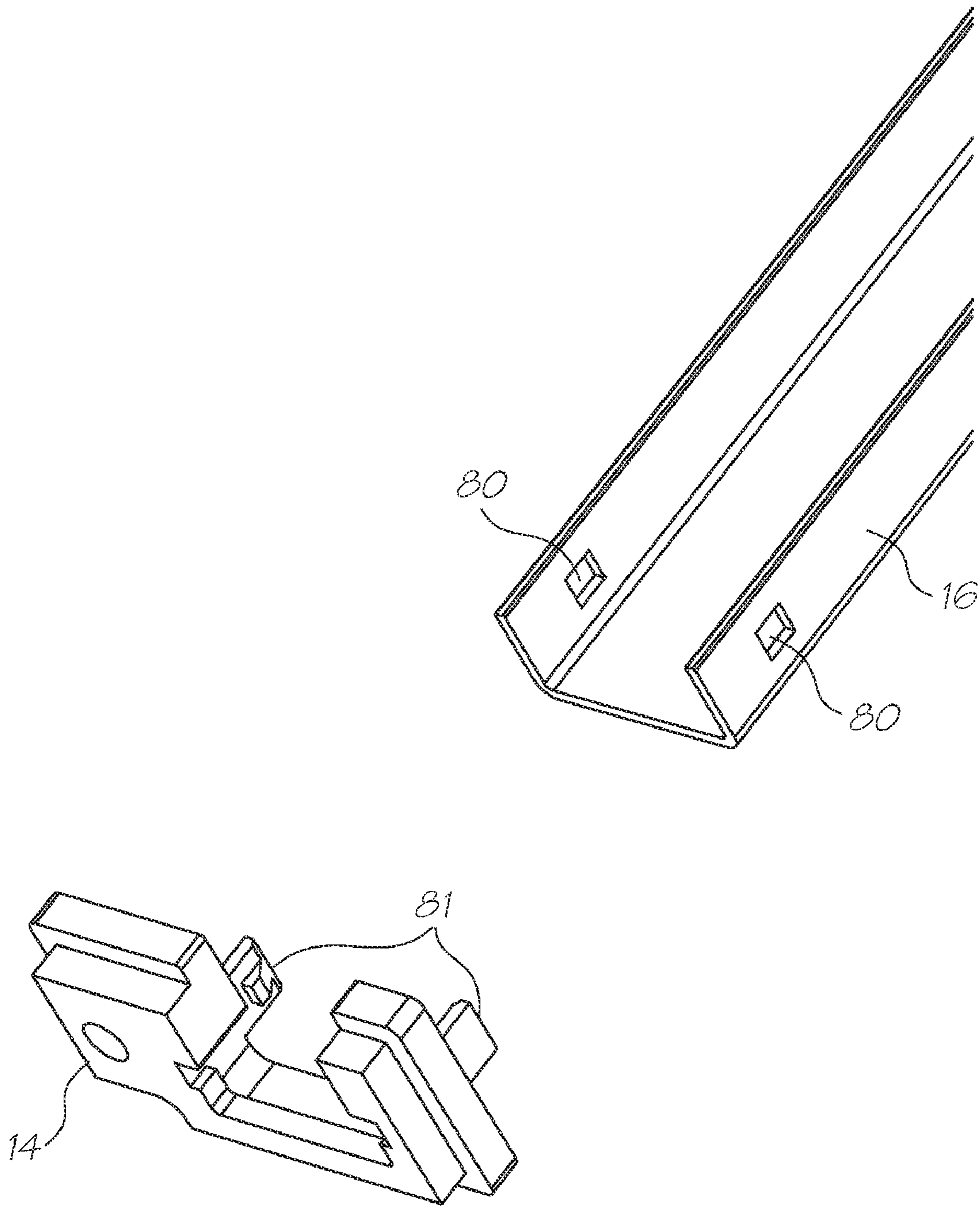
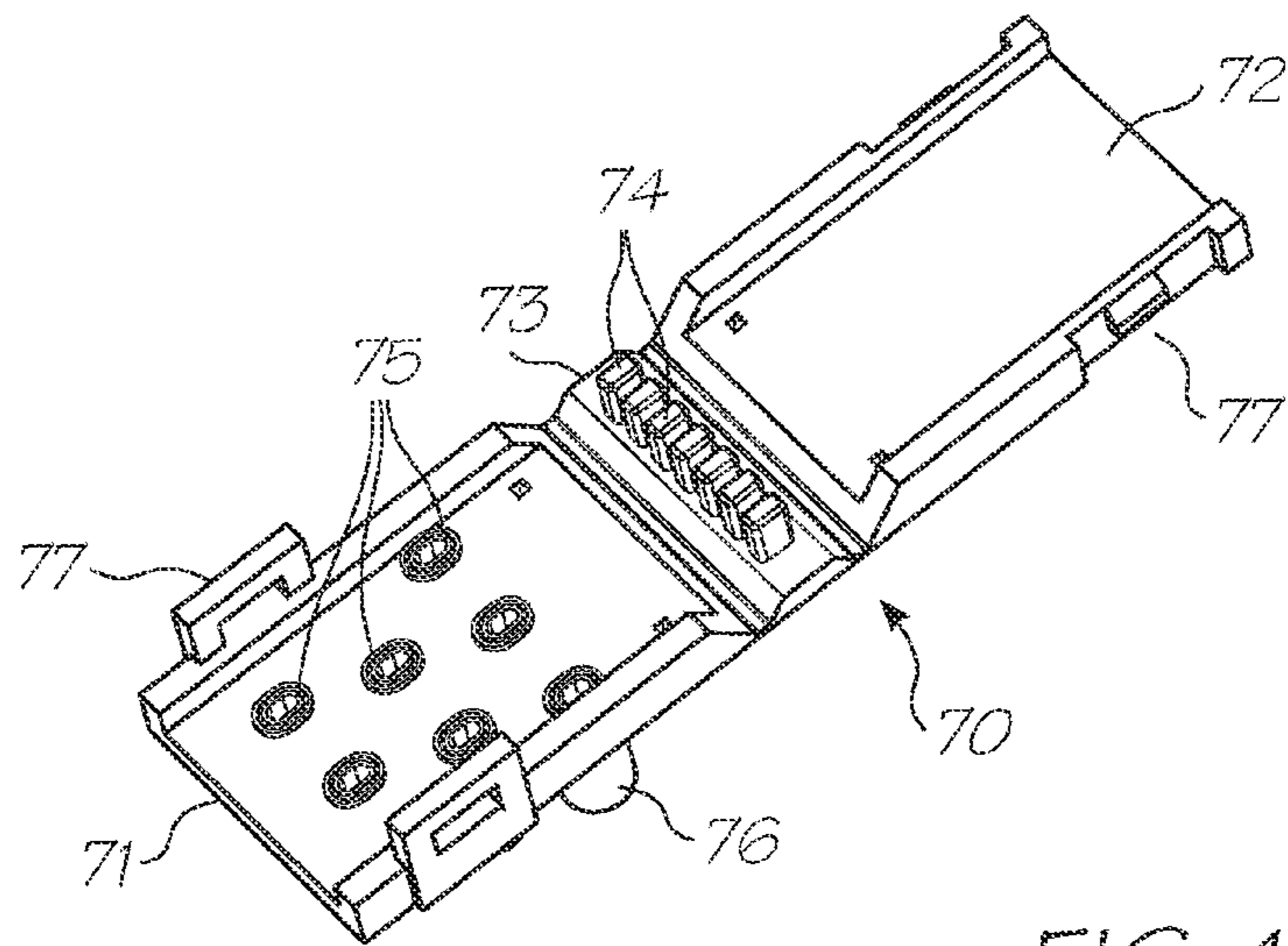
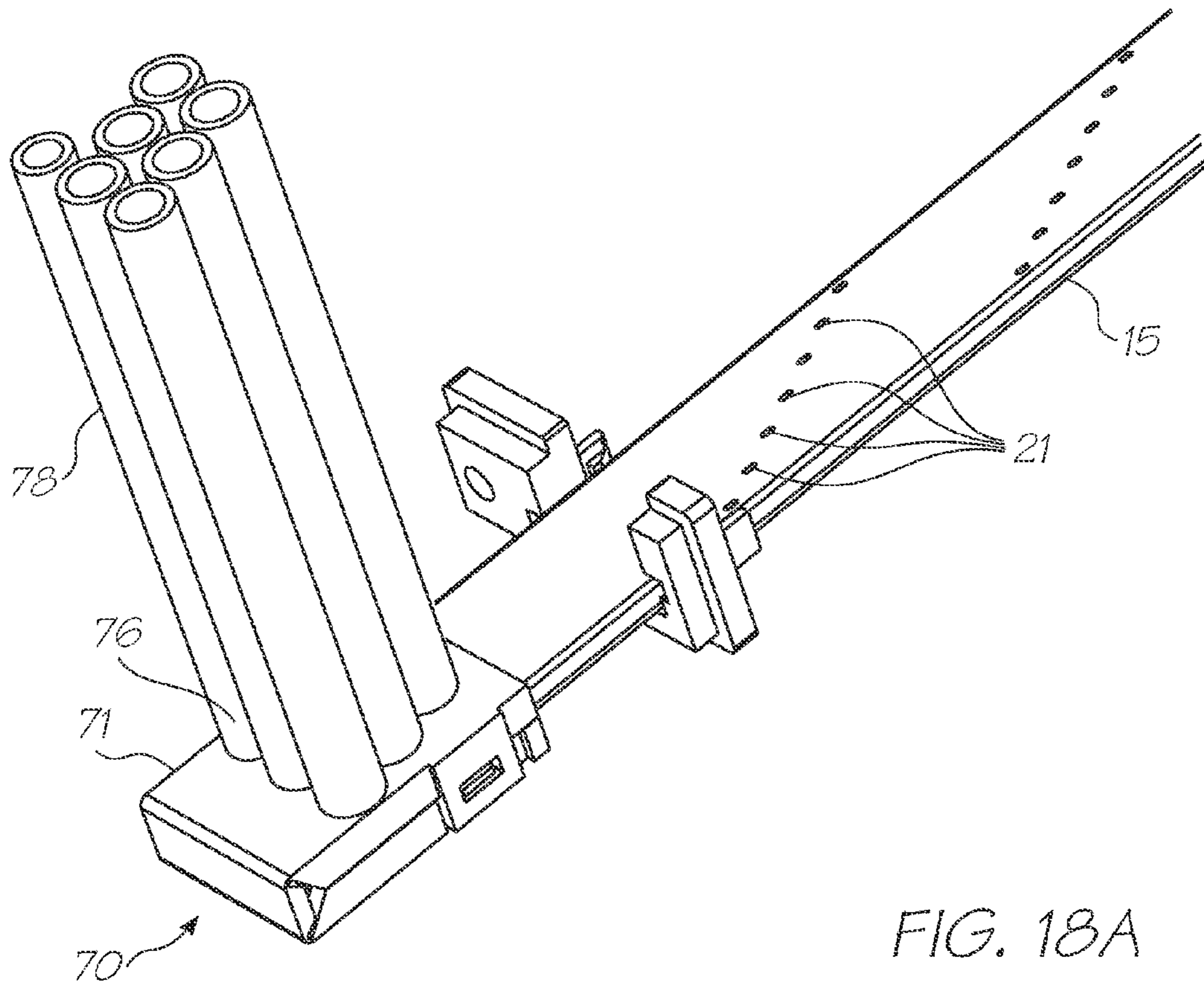

FIG. 17



## 1

**PRINthead ASSEMBLY WITH AIR  
EXPULSION ARRANGEMENT**CROSS REFERENCE TO RELATED  
APPLICATION

The present application is a Continuation of U.S. application Ser. No. 12/422,889 filed Apr. 13, 2009, now issued U.S. Pat. No. 7,677,699, which is a Continuation of U.S. application Ser. No. 11/635,485 filed Dec. 8, 2006, now issued U.S. Pat. No. 7,524,027, which is a Continuation of U.S. application Ser. No. 11/450,440 filed on Jun. 12, 2006, now issued U.S. Pat. No. 7,156,492, which is a Continuation of U.S. application Ser. No. 11/250,450 filed on Oct. 17, 2005, now issued U.S. Pat. No. 7,066,573, which is a Continuation of U.S. application Ser. No. 10/728,922 filed Dec. 8, 2003, now issued U.S. Pat. No. 6,997,545, which is a Continuation of U.S. application Ser. No. 10/102,700 filed on Mar. 22, 2002, now issued U.S. Pat. No. 6,692,113, all of which is herein incorporated by reference.

## CO-PENDING APPLICATIONS

Various methods, systems and apparatus relating to the present invention are disclosed in the following co-pending applications filed by the applicant or assignee of the present invention:

6,428,133	6,526,658	6,795,215	7,154,638
-----------	-----------	-----------	-----------

## BACKGROUND OF THE INVENTION

The following invention relates to a printhead module assembly for a printer.

More particularly, though not exclusively, the invention relates to a printhead module assembly for an A4 pagewidth drop on demand printer capable of printing up to 1600 dpi photographic quality at up to 160 pages per minute.

The overall design of a printer in which the printhead module assembly can be utilized revolves around the use of replaceable printhead modules in an array approximately 8½ inches (21 cm) long. An advantage of such a system is the ability to easily remove and replace any defective modules in a printhead array. This would eliminate having to scrap an entire printhead if only one chip is defective.

A printhead module in such a printer can be comprised of a "Memjet" chip, being a chip having mounted thereon a vast number of thermo-actuators in micro-mechanics and micro-electromechanical systems (MEMS). Such actuators might be those as disclosed in U.S. Pat. No. 6,044,646 to the present applicant, however, might be other MEMS print chips.

In a typical embodiment, eleven "Memjet" tiles can butt together in a metal channel to form a complete 8½ inch printhead assembly.

The printhead, being the environment within which the printhead module assemblies of the present invention are to be situated, might typically have six ink chambers and be capable of printing four color process (CMYK) as well as infrared ink and fixative. An air pump would supply filtered air through a seventh chamber to the printhead, which could be used to keep foreign particles away from its ink nozzles.

Each printhead module receives ink via an elastomeric extrusion that transfers the ink. Typically, the printhead

## 2

assembly is suitable for printing A4 paper without the need for scanning movement of the printhead across the paper width.

The printheads themselves are modular, so printhead arrays can be configured to form printheads of arbitrary width.

Additionally, a second printhead assembly can be mounted on the opposite side of a paper feed path to enable double-sided high-speed printing.

## SUMMARY OF THE INVENTION

According to an aspect of the present disclosure, a printhead assembly includes an elongate channel member of a metal alloy; a flexible elongate fluid carrier positioned on a floor of the channel member, the fluid carrier defining a plurality of passages longitudinally extending along a length of the fluid carrier, the fluid carrier further defining a repeated pattern of holes on an external surface thereof, the holes providing fluid communication from outside the fluid carrier to respective passages of the fluid carrier; and a series of printhead modules mounted to the external surface of the fluid carrier, each printhead module including an upper micro-molding and a lower micro-molding, the lower micro-molding having an air inlet slot in fluid communication with one of the plurality of passages via a hole of the repeated pattern of holes at one end and a series of alternating air inlets and outlets on the upper micro-molding at an opposite end. Each repeated pattern of holes diagonally spans a width of the fluid carrier, and the repeated pattern of holes together span a length of the fluid carrier. The alternating air inlets and outlets divert air from the air inlet slot to the printhead modules to facilitate cleaning of debris from the printhead modules.

## BRIEF DESCRIPTION OF THE DRAWINGS

A preferred form of the present invention will now be described by way of example with reference to the accompanying drawings wherein:

FIG. 1 is a schematic overall view of a printhead;

FIG. 2 is a schematic exploded view of the printhead of FIG. 1;

FIG. 3 is a schematic exploded view of an ink jet module;

FIG. 3A is a schematic exploded inverted illustration of the ink jet module of FIG. 3;

FIG. 4 is a schematic illustration of an assembled ink jet module;

FIG. 5 is a schematic inverted illustration of the module of FIG. 4;

FIG. 6 is a schematic close-up illustration of the module of FIG. 4;

FIG. 7 is a schematic illustration of a chip sub-assembly;

FIG. 8A is a schematic side elevational view of the printhead of FIG. 1;

FIG. 8B is a schematic plan view of the printhead of FIG. 8A;

FIG. 8C is a schematic side view (other side) of the printhead of FIG. 8A;

FIG. 8D is a schematic inverted plan view of the printhead of FIG. 8B;

FIG. 9 is a schematic cross-sectional end elevational view of the printhead of FIG. 1;

FIG. 10 is a schematic illustration of the printhead of FIG. 1 in an uncapped configuration;

FIG. 11 is a schematic illustration of the printhead of FIG. 10 in a capped configuration;

FIG. 12A is a schematic illustration of a capping device;

FIG. 12B is a schematic illustration of the capping device of FIG. 12a, viewed from a different angle;

FIG. 13 is a schematic illustration showing the loading of an ink jet module into a printhead;

FIG. 14 is a schematic end elevational view of the printhead illustrating the printhead module loading method;

FIG. 15 is a schematic cut-away illustration of the printhead assembly of FIG. 1;

FIG. 16 is a schematic close-up illustration of a portion of the printhead of FIG. 15 showing greater detail in the area of the "Memjet" chip;

FIG. 17 is a schematic illustration of the end portion of a metal channel and a printhead location molding;

FIG. 18A is a schematic illustration of an end portion of an elastomeric ink delivery extrusion and a molded end cap; and

FIG. 18B is a schematic illustration of the end cap of FIG. 18a in an out-folded configuration.

#### DETAILED DESCRIPTION OF THE INVENTION

In FIG. 1 of the accompanying drawings there is schematically depicted an overall view of a printhead assembly. FIG. 2 shows the core components of the assembly in an exploded configuration. The printhead assembly 10 of the preferred embodiment comprises eleven printhead modules 11 situated along a metal "Invar" channel 16. At the heart of each printhead module 11 is a "Memjet" chip 23 (FIG. 3). The particular chip chosen in the preferred embodiment being a six-color configuration.

The "Memjet" printhead modules 11 are comprised of the "Memjet" chip 23, a fine pitch flex PCB 26 and two micro-moldings 28 and 34 sandwiching a mid-package film 35. Each module 11 forms a sealed unit with independent ink chambers 63 (FIG. 9) which feed the chip 23. The modules 11 plug directly onto a flexible elastomeric extrusion 15 which carries air, ink and fixative (see channels 49-55 in FIG. 15). The upper surface of the extrusion 15 has repeated patterns of holes 21 which align with ink inlets 32 (FIG. 3a) on the underside of each module 11. The extrusion 15 is bonded onto a flex PCB (flexible printed circuit board).

The fine pitch flex PCB 26 wraps down the side of each printhead module 11 and makes contact with the flex PCB 17 (FIG. 9). The flex PCB 17 carries two busbars 19 (positive) and 20 (negative) for powering each module 11, as well as all data connections. The flex PCB 17 is bonded onto the continuous metal "Invar" channel 16. The metal channel 16 serves to hold the modules 11 in place and is designed to have a similar coefficient of thermal expansion to that of silicon used in the modules.

A capping device 12 is used to cover the "Memjet" chips 23 when not in use. The capping device is typically made of spring steel with an onsert molded elastomeric pad 47 (FIG. 12a). The pad 47 serves to duct air into the "Memjet" chip 23 when uncapped and cut off air and cover a nozzle guard 24 (FIG. 9) when capped. The capping device 12 is actuated by a camshaft 13 that typically rotates throughout 180°.

The overall thickness of the "Memjet" chip is typically 0.6 mm which includes a 150-micron inlet backing layer 27 and a nozzle guard 24 of 150-micron thickness. These elements are assembled at the wafer scale.

The nozzle guard 24 allows filtered air into an 80-micron cavity 64 (FIG. 16) above the "Memjet" ink nozzles 62. The pressurized air flows through microdroplet holes 45 in the nozzle guard 24 (with the ink during a printing operation) and serves to protect the delicate "Memjet" nozzles 62 by repelling foreign particles.

A silicon chip backing layer 27 ducts ink from the printhead module packaging directly into the rows of "Memjet" nozzles 62. The "Memjet" chip 23 is wire bonded 25 from bond pads on the chip at 116 positions to the fine pitch flex PCB 26. The wire bonds are on a 120-micron pitch and are cut as they are bonded onto the fine pitch flex PCB pads (FIG. 3). The fine pitch flex PCB 26 carries data and power from the flex PCB 17 via a series of gold contact pads 69 along the edge of the flex PCB.

The wire bonding operation between chip and fine pitch flex PCB 26 may be done remotely, before transporting, placing and adhering the chip assembly into the printhead module assembly. Alternatively, the "Memjet" chips 23 can be adhered into the upper micro-molding 28 first and then the fine pitch flex PCB 26 can be adhered into place. The wire bonding operation could then take place in situ, with no danger of distorting the moldings 28 and 34. The upper micro-molding 28 can be made of a Liquid Crystal Polymer (LCP) blend. Since the crystal structure of the upper micro-molding 28 is minute, the heat distortion temperature (180° C.-260° C.), the continuous usage temperature (200° C.-240° C.) and soldering heat durability (260° C. for 10 seconds to 310° C. for 10 seconds) are high, regardless of the relatively low melting point.

Each printhead module 11 includes an upper micro-molding 28 and a lower micro-molding 34 separated by a mid-package film layer 35 shown in FIG. 3.

The mid-package film layer 35 can be an inert polymer such as polyimide, which has good chemical resistance and dimensional stability. The mid-package film layer 35 can have laser ablated holes 65 and can comprise a double-sided adhesive (ie. an adhesive layer on both faces) providing adhesion between the upper micro-molding, the mid-package film layer and the lower micro-molding.

The upper micro-molding 28 has a pair of alignment pins 29 passing through corresponding apertures in the mid-package film layer 35 to be received within corresponding recesses 66 in the lower micro-molding 34. This serves to align the components when they are bonded together. Once bonded together, the upper and lower micro-moldings form a tortuous ink and air path in the complete "Memjet" printhead module 11. In addition, an upper surface of the upper micro-molding 28 has a pair of opposed recesses 39 which serve as robot pick-up points for picking and placing the micro-molding.

There are annular ink inlets 32 in the underside of the lower micro-molding 34. In a preferred embodiment, there are six such inlets 32 for various inks (black, yellow, magenta, cyan, fixative and infrared). There is also provided an air inlet slot 67. The air inlet slot 67 extends across the lower micro-molding 34 to a secondary inlet which expels air through an exhaust hole 33, through an aligned hole 68 in fine pitch flex PCB 26. This serves to repel the print media from the printhead during printing. The ink inlets 32 continue in the underside of the upper micro-molding 28 as does a path from the air inlet slot 67. The ink inlets lead to 200 micron exit holes also indicated at 32 in FIG. 3. These holes correspond to the inlets on the silicon backing layer 27 of the "Memjet" chip 23.

There is a pair of elastomeric pads 36 on an edge of the lower micro-molding 34. These serve to take up tolerance and positively located the printhead modules 11 into the metal channel 16 when the modules are micro-placed during assembly.

A preferred material for the "Memjet" micro-moldings is a LCP. This has suitable flow characteristics for the fine detail in the moldings and has a relatively low coefficient of thermal expansion.

Robot picker details are included in the upper micro-molding **28** to enable accurate placement of the printhead modules **11** during assembly.

The upper surface of the upper micro-molding **28** as shown in FIG. **3** has a series of alternating air inlets and outlets **31**. These act in conjunction with the capping device **12** and are either sealed off or grouped into air inlet/outlet chambers, depending upon the position of the capping device **12**. They connect air diverted from the inlet slot **67** to the chip **23** depending upon whether the unit is capped or uncapped.

A capper cam detail **40** including a ramp for the capping device is shown at two locations in the upper surface of the upper micro-molding **28**. This facilitates a desirable movement of the capping device **12** to cap or uncap the chip and the air chambers. That is, as the capping device is caused to move laterally across the print chip during a capping or uncapping operation, the ramp of the capper cam detail **40** serves to elastically distort and capping device as it is moved by operation of the camshaft **13** so as to prevent scraping of the device against the nozzle guard **24**.

The “Memjet” chip assembly **23** is picked and bonded into the upper micro-molding **28** on the printhead module **11**. The fine pitch flex PCB **26** is bonded and wrapped around the side of the assembled printhead module **11** as shown in FIG. **4**. After this initial bonding operation, the chip **23** has more sealant or adhesive **46** applied to its long edges. This serves to “pot” the bond wires **25** (FIG. **6**), seal the “Memjet” chip **23** to the molding **28** and form a sealed gallery into which filtered air can flow and exhaust through the nozzle guard **24**.

The flex PCB **17** carries all data and power connections from the main PCB (not shown) to each “Memjet” printhead module **11**. The flex PCB **17** has a series of gold plated, domed contacts **69** (FIG. **2**) which interface with contact pads **41**, **42** and **43** that are located, together with section **44**, on the fine pitch flex PCB **26** of each “Memjet” printhead module **11**.

Two copper busbar strips **19** and **20**, typically of 200 micron thickness, are jigged and soldered into place on the flex PCB **17**. The busbars **19** and **20** connect to a flex termination which also carries data.

The flex PCB **17** is approximately 340 mm in length and is formed from a 14 mm wide strip. It is bonded into the metal channel **16** during assembly and exits from one end of the printhead assembly only.

The metal U-channel **16** into which the main components are placed is of a special alloy called “Invar **36**”. It is a 36% nickel iron alloy possessing a coefficient of thermal expansion of  $\frac{1}{10}^{th}$  that of carbon steel at temperatures up to 400° F. The Invar is annealed for optimal dimensional stability.

Additionally, the Invar is nickel plated to a 0.056% thickness of the wall section. This helps to further match it to the coefficient of thermal expansion of silicon which is  $2 \times 10^{-6}$  per ° C.

The Invar channel **16** functions to capture the “Memjet” printhead modules **11** in a precise alignment relative to each other and to impart enough force on the modules **11** so as to form a seal between the ink inlets **32** on each printhead module and the outlet holes **21** that are laser ablated into the elastomeric ink delivery extrusion **15**.

The similar coefficient of thermal expansion of the Invar channel to the silicon chips allows similar relative movement during temperature changes. The elastomeric pads **36** on one side of each printhead module **11** serve to “lubricate” them within the channel **16** to take up any further lateral coefficient of thermal expansion tolerances without losing alignment. The Invar channel is a cold rolled, annealed and nickel plated strip. Apart from two bends that are required in its formation,

the channel has two square cut-outs **80** at each end. These mate with snap fittings **81** on the printhead location moldings **14** (FIG. **17**).

The elastomeric ink delivery extrusion **15** is a non-hydrophobic, precision component. Its function is to transport ink and air to the “Memjet” printhead modules **11**. The extrusion is bonded onto the top of the flex PCB **17** during assembly and it has two types of molded end caps. One of these end caps is shown at **70** in FIG. **18a**.

A series of patterned holes **21** are present on the upper surface of the extrusion **15**. These are laser ablated into the upper surface. To this end, a mask is made and placed on the surface of the extrusion, which then has focused laser light applied to it. The holes **21** are evaporated from the upper surface, but the laser does not cut into the lower surface of extrusion **15** due to the focal length of the laser light.

Eleven repeated patterns of the laser ablated holes **21** form the ink and air outlets **21** of the extrusion **15**. These interface with the annular ring inlets **32** on the underside of the “Memjet” printhead module lower micro-molding **34**. A different pattern of larger holes (not shown but concealed beneath the upper plate **71** of end cap **70** in FIG. **18a**) is ablated into one end of the extrusion **15**. These mate with apertures **75** having annular ribs formed in the same way as those on the underside of each lower micro-molding **34** described earlier. Ink and air delivery hoses **78** are connected to respective connectors **76** that extend from the upper plate **71**. Due to the inherent flexibility of the extrusion **15**, it can contort into many ink connection mounting configurations without restricting ink and air flow. The molded end cap **70** has a spine **73** from which the upper and lower plates are integrally hinged. The spine **73** includes a row of plugs **74** that are received within the ends of the respective flow passages of the extrusion **15**.

The other end of the extrusion **15** is capped with simple plugs **18** which block the channels in a similar way as the plugs **74** on spine **17**.

The end cap **70** clamps onto the ink extrusion **15** by way of snap engagement tabs **77**. Once assembled with the delivery hoses **78**, ink and air can be received from ink reservoirs and an air pump, possibly with filtration means. The end cap **70** can be connected to either end of the extrusion, i.e. at either end of the printhead.

The plugs **74** are pushed into the channels of the extrusion **15** and the plates **71** and **72** are folded over. The snap engagement tabs **77** clamp the molding and prevent it from slipping off the extrusion. As the plates are snapped together, they form a sealed collar arrangement around the end of the extrusion. Instead of providing individual hoses **78** pushed onto the connectors **76**, the molding **70** might interface directly with an ink cartridge. A sealing pin arrangement can also be applied to this molding **70**. For example, a perforated, hollow metal pin with an elastomeric collar can be fitted to the top of the inlet connectors **76**. This would allow the inlets to automatically seal with an ink cartridge when the cartridge is inserted. The air inlet and hose might be smaller than the other inlets in order to avoid accidental charging of the airways with ink.

The capping device **12** for the “Memjet” printhead would typically be formed of stainless spring steel. An elastomeric seal or onsert molding **47** is attached to the capping device as shown in FIGS. **12a** and **12b**. The metal part from which the capping device is made is punched as a blank and then inserted into an injection molding tool ready for the elastomeric onsert to be shot onto its underside. Small holes **79** (FIG. **13b**) are present on the upper surface of the metal capping device **12** and can be formed as burst holes. They serve to key the onsert molding **47** to the metal. After the



molding **47** is applied, the blank is inserted into a press tool, where additional bending operations and forming of integral springs **48** takes place.

The elastomeric onsert molding **47** has a series of rectangular recesses or air chambers **56**. These create chambers when uncapped. The chambers **56** are positioned over the air inlet and exhaust holes **30** of the upper micro-molding **28** in the "Memjet" printhead module **11**. These allow the air to flow from one inlet to the next outlet. When the capping device **12** is moved forward to the "home" capped position as depicted in FIG. **11**, these airways **32** are sealed off with a blank section of the onsert molding **47** cutting off airflow to the "Memjet" chip **23**. This prevents the filtered air from drying out and therefore blocking the delicate "Memjet" nozzles.

Another function of the onsert molding **47** is to cover and clamp against the nozzle guard **24** on the "Memjet" chip **23**. This protects against drying out, but primarily keeps foreign particles such as paper dust from entering the chip and damaging the nozzles. The chip is only exposed during a printing operation, when filtered air is also exiting along with the ink drops through the nozzle guard **24**. This positive air pressure repels foreign particles during the printing process and the capping device protects the chip in times of inactivity.

The integral springs **48** bias the capping device **12** away from the side of the metal channel **16**. The capping device **12** applies a compressive force to the top of the printhead module **11** and the underside of the metal channel **16**. The lateral capping motion of the capping device **12** is governed by an eccentric camshaft **13** mounted against the side of the capping device. It pushes the device **12** against the metal channel **16**. During this movement, the bosses **57** beneath the upper surface of the capping device **12** ride over the respective ramps **40** formed in the upper micro-molding **28**. This action flexes the capping device and raises its top surface to raise the onsert molding **47** as it is moved laterally into position onto the top of the nozzle guard **24**.

The camshaft **13**, which is reversible, is held in position by two printhead location moldings **14**. The camshaft **11** can have a flat surface built in one end or be otherwise provided with a spline or keyway to accept gear **22** or another type of motion controller.

The "Memjet" chip and printhead module are assembled as follows:

1. The "Memjet" chip **23** is dry tested in flight by a pick and place robot, which also dices the wafer and transports individual chips to a fine pitch flex PCB bonding area.
2. When accepted, the "Memjet" chip **23** is placed 530 microns apart from the fine pitch flex PCB **26** and has wire bonds **25** applied between the bond pads on the chip and the conductive pads on the fine pitch flex PCB. This constitutes the "Memjet" chip assembly.
3. An alternative to step **2** is to apply adhesive to the internal walls of the chip cavity in the upper micro-molding **28** of the printhead module and bond the chip into place first. The fine pitch flex PCB **26** can then be applied to the upper surface of the micro-molding and wrapped over the side. Wire bonds **25** are then applied between the bond pads on the chip and the fine pitch flex PCB.
4. The "Memjet" chip assembly is vacuum transported to a bonding area where the printhead modules are stored.
5. Adhesive is applied to the lower internal walls of the chip cavity and to the area where the fine pitch flex PCB is going to be located in the upper micro-molding of the printhead module.
6. The chip assembly (and fine pitch flex PCB) are bonded into place. The fine pitch flex PCB is carefully wrapped

around the side of the upper micro-molding so as not to strain the wire bonds. This may be considered as a two step gluing operation if it is deemed that the fine pitch flex PCB might stress the wire bonds. A line of adhesive running parallel to the chip can be applied at the same time as the internal chip cavity walls are coated. This allows the chip assembly and fine pitch flex PCB to be seated into the chip cavity and the fine pitch flex PCB allowed to bond to the micro-molding without additional stress. After curing, a secondary gluing operation could apply adhesive to the short side wall of the upper micro-molding in the fine pitch flex PCB area. This allows the fine pitch flex PCB to be wrapped around the micro-molding and secured, while still being firmly bonded in place along on the top edge under the wire bonds.

7. In the final bonding operation, the upper part of the nozzle guard is adhered to the upper micro-molding, forming a sealed air chamber. Adhesive is also applied to the opposite long edge of the "Memjet" chip, where the bond wires become 'potted' during the process.
8. The modules are 'wet' tested with pure water to ensure reliable performance and then dried out.
9. The modules are transported to a clean storage area, prior to inclusion into a printhead assembly, or packaged as individual units. This completes the assembly of the "Memjet" printhead module assembly.
10. The metal Invar channel **16** is picked and placed in a jig.
11. The flex PCB **17** is picked and primed with adhesive on the busbar side, positioned and bonded into place on the floor and one side of the metal channel.
12. The flexible ink extrusion **15** is picked and has adhesive applied to the underside. It is then positioned and bonded into place on top of the flex PCB **17**. One of the printhead location end caps is also fitted to the extrusion exit end. This constitutes the channel assembly.

The laser ablation process is as follows:

13. The channel assembly is transported to an eximir laser ablation area.
  14. The assembly is put into a jig, the extrusion positioned, masked and laser ablated. This forms the ink holes in the upper surface.
  15. The ink extrusion **15** has the ink and air connector molding **70** applied. Pressurized air or pure water is flushed through the extrusion to clear any debris.
  16. The end cap molding **70** is applied to the extrusion **15**. It is then dried with hot air.
  17. The channel assembly is transported to the printhead module area for immediate module assembly. Alternatively, a thin film can be applied over the ablated holes and the channel assembly can be stored until required.
- The printhead module to channel is assembled as follows:
18. The channel assembly is picked, placed and clamped into place in a transverse stage in the printhead assembly area.
  19. As shown in FIG. **14**, a robot tool **58** grips the sides of the metal channel and pivots at pivot point against the underside face to effectively flex the channel apart by 200 to 300 microns. The forces applied are shown generally as force vectors **F** in FIG. **14**. This allows the first "Memjet" printhead module to be robot picked and placed (relative to the first contact pads on the flex PCB **17** and ink extrusion holes) into the channel assembly. This is further facilitated by a recess **59** formed in the body of each module **11**.

20. The tool **58** is relaxed, the printhead module captured by the resilience of the Invar channel and the transverse stage moves the assembly forward by 19.81 mm.
21. The tool **58** grips the sides of the channel again and flexes it apart ready for the next printhead module. 5
22. A second printhead module **11** is picked and placed into the channel 50 microns from the previous module.
23. An adjustment actuator arm locates the end of the second printhead module. The arm is guided by the optical alignment of fiducials on each strip. As the 10 adjustment arm pushes the printhead module over, the gap between the fiducials is closed until they reach an exact pitch of 19.812 mm.
24. The tool **58** is relaxed and the adjustment arm is removed, securing the second printhead module in place. 15
25. This process is repeated until the channel assembly has been fully loaded with printhead modules. The unit is removed from the transverse stage and transported to the capping assembly area. Alternatively, a thin film can be 20 applied over the nozzle guards of the printhead modules to act as a cap and the unit can be stored as required.
- The capping device is assembled as follows:
26. The printhead assembly is transported to a capping area. The capping device **12** is picked, flexed apart 25 slightly and pushed over the first module **11** and the metal channel **16** in the printhead assembly. It automatically seats itself into the assembly by virtue of the bosses **57** in the steel locating in the recesses **83** in the upper micro-molding in which a respective ramp **40** is located. 30
27. Subsequent capping devices are applied to all the printhead modules.
28. When completed, the camshaft **13** is seated into the printhead location molding **14** of the assembly. It has the second printhead location molding seated onto the free 35 end and this molding is snapped over the end of the metal channel, holding the camshaft and capping devices captive.
29. A molded gear **22** or other motion control device can be added to either end of the camshaft **13** at this point. 40
30. The capping assembly is mechanically tested.

Print charging is as follows:

31. The printhead assembly **10** is moved to the testing area. Inks are applied through the "Memjet" modular printhead under pressure. Air is expelled through the "Memjet" 45 nozzles during priming. When charged, the printhead can be electrically connected and tested.
32. Electrical connections are made and tested as follows:
33. Power and data connections are made to the PCB. Final testing can commence, and when passed, the "Memjet" 50 modular printhead is capped and has a plastic sealing film applied over the underside that protects the printhead until product installation.

We claim:

- 1.** A printhead assembly comprising:  
 an elongate channel member of a metal alloy;  
 a flexible elongate fluid carrier positioned on a floor of the channel member, the fluid carrier defining a plurality of passages longitudinally extending along a length of the fluid carrier, the fluid carrier further defining a repeated

pattern of holes on an external surface thereof, the holes providing fluid communication from outside the fluid carrier to respective passages of the fluid carrier; and  
 a series of printhead modules mounted to the external surface of the fluid carrier, each printhead module including an upper micro-molding and a lower micro-molding, the lower micro-molding having an air inlet slot in fluid communication with one of the plurality of passages via a hole of the repeated pattern of holes at one end and a series of alternating air inlets and outlets on the upper micro-molding at an opposite end, wherein each repeated pattern of holes diagonally spans a width of the fluid carrier, and the repeated pattern of holes together span a length of the fluid carrier, and the alternating air inlets and outlets divert air from the air inlet slot to the printhead modules to facilitate cleaning of debris from the printhead modules.

**2.** A printhead assembly as claimed in claim **1**, wherein the upper micro-molding further comprises an exhaust hole aligned with the air inlet slot and through which air carried in one of the passages is expelled.

**3.** A printhead assembly as claimed in claim **2**, wherein the air expelled through the exhaust hole facilitates repulsion of a print media from the printhead.

**4.** A printhead assembly as claimed in claim **1**, wherein the air inlet slot spans a width of the lower micro-molding.

**5.** A printhead assembly as claimed in claim **1**, further comprising a plurality of inlets, the plurality of inlets diagonally spanning a width of the lower micro-molding such that the plurality of inlets, together with a portion of the air inlet slot, align with a repeated pattern of holes. 30

**6.** A printhead assembly as claimed in claim **1**, wherein the elongate channel member is of a nickel iron alloy.

**7.** A printhead assembly as claimed in claim **1**, wherein the printhead modules are snap-fitted to the channel member. 35

**8.** A printhead assembly as claimed in claim **1**, wherein the fluid carrier is an extrusion of an elastomeric material.

**9.** A printhead assembly as claimed in claim **1**, further comprising an end cap for capping one end of the fluid carrier, the end cap having holes defined therethrough to which a connector is mated. 40

**10.** A printhead assembly as claimed in claim **9**, further comprising a set of hoses for connecting to the connector, the hoses for supplying fluid to the fluid carrier via the connector and end cap. 45

**11.** A printhead assembly as claimed in claim **1**, wherein the upper micro-molding arranged is configured to carry a flexible printhead IC.

**12.** A printhead assembly as claimed in claim **11**, in which a mid-package film layer is interposed between the upper and lower micro-moldings. 50

**13.** A printhead assembly as claimed in claim **1**, further comprising an onsert molding for capping a printhead of each printhead module.

**14.** A printhead assembly as claimed in claim **13**, wherein the onsert molding includes a series of rectangular recesses, the series of rectangular recesses forming air chambers with the alternating air inlets and outlets to facilitating air to flow from one inlet into an adjacent outlet. 55