

US007963868B2

(12) **United States Patent**
McGrath et al.

(10) **Patent No.:** **US 7,963,868 B2**
(45) **Date of Patent:** **Jun. 21, 2011**

- (54) **HOCKEY STICK**
- (75) Inventors: **Michael J. McGrath**, Coronado, CA (US); **Roman D. Halko**, Chula Vista, CA (US); **Edward M. Goldsmith**, Studio City, CA (US)
- (73) Assignee: **Easton Sports, Inc.**, Van Nuys, CA (US)
- (*) Notice: Subject to any disclaimer, the term of this patent is extended or adjusted under 35 U.S.C. 154(b) by 0 days.
- (21) Appl. No.: **10/439,652**
- (22) Filed: **May 15, 2003**

- 2,674,557 A 4/1954 Boggs
- 2,762,739 A 9/1956 Weiss
- 2,774,596 A 12/1956 Bredenberg
- 2,912,245 A 11/1959 Gardner et al.
- 2,964,065 A 12/1960 Haroldson
- 3,020,192 A 2/1962 Stephens et al.
- 3,125,478 A 3/1964 Pratt
- 3,353,826 A 11/1967 Traverse
- 3,489,412 A 1/1970 Franck et al.
- 3,533,623 A 10/1970 Dumont
- 3,544,104 A 12/1970 Jenks
- 3,561,760 A 2/1971 Klay
- 3,563,546 A 2/1971 Dawe
- 3,606,326 A 9/1971 Sparks et al.
- 3,631,897 A 1/1972 Fischer et al.

(Continued)

- (65) **Prior Publication Data**
US 2004/0235592 A1 Nov. 25, 2004

FOREIGN PATENT DOCUMENTS

- CA 489072 12/1952
- (Continued)

Related U.S. Application Data

- (63) Continuation-in-part of application No. 10/290,052, filed on Nov. 6, 2002, now abandoned, which is a continuation of application No. 09/663,598, filed on Sep. 15, 2000, now abandoned.
- (60) Provisional application No. 60/380,900, filed on May 15, 2002, provisional application No. 60/418,067, filed on Oct. 11, 2002.

OTHER PUBLICATIONS

Polyurethane Foam Association, Joint Industry Foam Standards and Guidelines, Jul. 1994, 5 pages from website.*

(Continued)

- (51) **Int. Cl.**
A63B 59/14 (2006.01)
 - (52) **U.S. Cl.** **473/563**
 - (58) **Field of Classification Search** 473/560-563,
473/519, 520
- See application file for complete search history.

Primary Examiner — Mark S Graham

(74) *Attorney, Agent, or Firm* — Perkins Coie LLP

- (56) **References Cited**

U.S. PATENT DOCUMENTS

- 1,601,116 A * 9/1926 Hall 473/562
- 2,201,706 A 5/1940 Sukohl
- 2,304,322 A 12/1942 Werlich
- 2,649,133 A 8/1953 Just

(57) **ABSTRACT**

Hockey stick configurations and hockey stick blade constructs are disclosed. The blade is comprised of one or more inner core elements, surrounded by one or more walls made of reinforcing fibers or filaments disposed in a hardened matrix resin material. One or more of the inner core elements comprises an elastomer material.

4 Claims, 20 Drawing Sheets

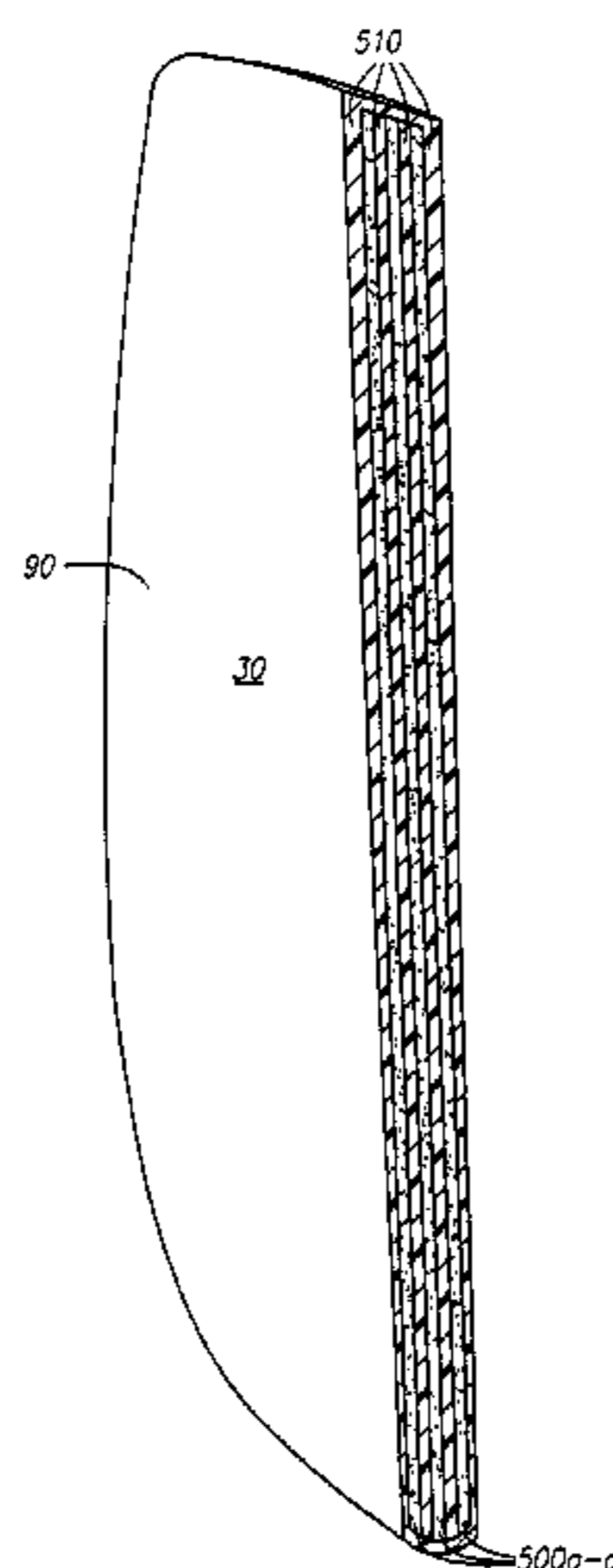

U.S. PATENT DOCUMENTS							
3,638,942	A	2/1972	Bassett	5,067,726	A	11/1991	Brine, III et al.
3,727,936	A	4/1973	Klir et al.	5,076,872	A	12/1991	Nakagawa et al.
3,809,401	A	5/1974	Hankele	5,078,396	A	1/1992	Cavallaro et al.
3,813,098	A	5/1974	Fischer et al.	5,127,649	A	7/1992	Carbonero
3,851,880	A	12/1974	Ritch	D329,888	S	9/1992	Christian
3,859,162	A	1/1975	Johnson et al.	5,160,135	A	11/1992	Hasegawa
3,910,578	A	10/1975	Brine, Jr.	5,174,567	A	12/1992	Nordstrom
3,934,875	A	1/1976	Easton et al.	5,183,264	A	2/1993	Lanctot
3,961,790	A	6/1976	Milligan	5,188,872	A	2/1993	Quigley
3,970,324	A	7/1976	Howat	5,206,085	A	4/1993	Nakagawa et al.
3,982,760	A	9/1976	Titola	5,217,221	A	* 6/1993	Baum 473/561
4,013,288	A	3/1977	Goverde	5,242,637	A	9/1993	Inoue et al.
4,013,810	A	3/1977	Long	5,261,662	A	11/1993	Prevost
4,016,640	A	4/1977	Briggs	5,303,916	A	4/1994	Rodgers
D244,790	S	6/1977	Carlson et al.	5,306,003	A	4/1994	Pagotto
4,052,499	A	10/1977	Goupil et al.	5,312,100	A	5/1994	Iacqua et al.
4,059,269	A	11/1977	Tiitola	5,332,212	A	7/1994	Susi et al.
4,061,520	A	12/1977	Cecka et al.	5,333,857	A	* 8/1994	Lallemand 473/561
4,070,020	A	1/1978	Dano	5,364,693	A	11/1994	Moren et al.
4,070,021	A	1/1978	Cecka et al.	5,373,616	A	12/1994	Biersdorf et al.
4,076,240	A	2/1978	Haddad	5,380,002	A	1/1995	Spector
4,084,818	A	4/1978	Goupil et al.	5,407,195	A	* 4/1995	Tiitola et al. 473/563
4,086,115	A	4/1978	Sweet, Jr. et al.	5,419,553	A	5/1995	Rodgers
4,124,208	A	* 11/1978	Burns 473/562	5,423,531	A	6/1995	Hoshizaki et al.
4,124,670	A	11/1978	Cecka et al.	5,423,735	A	6/1995	Callinan et al.
4,128,963	A	12/1978	Dano	5,435,548	A	7/1995	Leduke et al.
4,129,634	A	12/1978	Cecka et al.	5,439,215	A	8/1995	Ratchford
4,134,198	A	1/1979	Briggs	5,456,463	A	10/1995	Dolan et al.
4,134,587	A	1/1979	Diederich	5,458,330	A	10/1995	Baum
4,148,482	A	4/1979	Harwell, Jr. et al.	RE35,081	E	11/1995	Quigley
4,159,114	A	6/1979	Ardell et al.	5,470,067	A	11/1995	Diresta
4,172,594	A	10/1979	Diederich	5,492,425	A	2/1996	Carter et al.
4,180,413	A	12/1979	Diederich	5,496,027	A	3/1996	Christian et al.
4,200,479	A	4/1980	Ardell et al.	5,511,776	A	4/1996	Huru
4,212,461	A	7/1980	Cecka et al.	5,520,385	A	5/1996	Quigley et al.
4,239,215	A	12/1980	Farr	5,524,884	A	6/1996	Haines
4,241,115	A	12/1980	Temin	5,533,723	A	7/1996	Baum
4,273,601	A	6/1981	Weingart	5,549,947	A	8/1996	Quigley et al.
4,320,160	A	3/1982	Nishimura et al.	5,556,677	A	9/1996	Quigley et al.
4,343,468	A	8/1982	Lindgren	5,558,326	A	9/1996	Adamson et al.
4,351,528	A	9/1982	Duplin	5,577,725	A	11/1996	Pagotto et al.
4,353,549	A	10/1982	Goupil et al.	5,582,405	A	12/1996	Montgomery
4,358,113	A	* 11/1982	McKinnon et al. 473/561	5,582,406	A	12/1996	Babcock
4,358,117	A	11/1982	Deutsch	5,593,158	A	1/1997	Filice
4,361,325	A	11/1982	Jansen	5,599,242	A	2/1997	Solviche et al.
4,369,970	A	1/1983	Salminen	5,603,498	A	2/1997	Crawford et al.
4,461,479	A	7/1984	Mitchell	5,605,327	A	2/1997	McCutchen
4,488,721	A	* 12/1984	Franck et al. 473/563	5,607,154	A	3/1997	Meumann et al.
4,504,344	A	3/1985	Helle et al.	5,607,226	A	3/1997	Toth et al.
4,512,573	A	4/1985	Coolen	5,624,115	A	4/1997	Baum
4,520,042	A	5/1985	Smith	5,628,509	A	5/1997	Christian
4,537,398	A	8/1985	Salminen	5,633,299	A	5/1997	Van Druten et al.
4,570,932	A	2/1986	Cote	5,636,836	A	6/1997	Carroll et al.
4,579,617	A	4/1986	Öberg et al.	5,653,468	A	8/1997	Ostapyk
4,591,155	A	5/1986	Adachi	5,653,643	A	8/1997	Falone et al.
4,600,192	A	* 7/1986	Adachi 473/561	5,655,981	A	8/1997	Reed
4,651,990	A	3/1987	Profit	5,674,141	A	10/1997	Laforest
4,660,832	A	4/1987	Shomo	5,676,608	A	10/1997	Christian et al.
4,664,379	A	5/1987	Melby	5,685,791	A	11/1997	Feeney
4,684,130	A	8/1987	Drolet et al.	5,685,792	A	11/1997	Ruoff
4,739,994	A	4/1988	Lewis, Jr.	5,688,571	A	11/1997	Quigley et al.
4,765,856	A	8/1988	Doubt	5,690,850	A	11/1997	Anderson
4,770,915	A	9/1988	Nakagawa et al.	5,695,416	A	12/1997	Christian
4,793,616	A	12/1988	Fernandez	5,697,857	A	12/1997	Christian et al.
4,799,985	A	1/1989	McMahon et al.	5,700,533	A	12/1997	You
4,818,318	A	4/1989	McMahon et al.	5,718,647	A	2/1998	Tiitola
4,871,491	A	10/1989	McMahon et al.	5,728,008	A	3/1998	Howard
4,874,563	A	10/1989	McMahon et al.	5,728,016	A	3/1998	Hsu
4,923,541	A	5/1990	Burger	5,744,528	A	4/1998	Callinan et al.
4,968,032	A	11/1990	Redekop	5,746,955	A	5/1998	Calapp et al.
4,979,743	A	12/1990	Sears	5,772,541	A	6/1998	Buiatti
5,005,254	A	4/1991	Uffindell	5,816,949	A	10/1998	Dutchburn
5,024,712	A	6/1991	Lecourt et al.	5,816,962	A	10/1998	Etersque
5,042,804	A	8/1991	Uke et al.	5,816,963	A	10/1998	Brooks et al.
5,042,805	A	8/1991	Nakai	5,823,901	A	10/1998	Burger
5,048,441	A	9/1991	Quigley	5,827,141	A	10/1998	Lukey et al.
5,050,289	A	9/1991	Uffindell	5,839,977	A	11/1998	Maurer et al.
5,050,878	A	9/1991	Deleris	D404,449	S	1/1999	Burger
				5,863,268	A	1/1999	Birch

5,863,269 A	1/1999	Fillice	2002/0128093 A1	9/2002	Wayne
5,865,694 A	2/1999	Duong-Van	2002/0166595 A1	11/2002	Lindsay
5,865,696 A	2/1999	Calapp et al.	2002/0177497 A1	11/2002	Westerlund
5,866,051 A	2/1999	Lin et al.	2002/0198071 A1	12/2002	Snow
5,879,250 A	3/1999	Tahtinen et al.	2003/0004019 A1	1/2003	Lussier et al.
5,888,601 A	3/1999	Quigley et al.	2003/0008734 A1	1/2003	Tiitola
5,904,873 A	5/1999	Sadler et al.	2003/0045380 A1	3/2003	Tucker
5,928,090 A	7/1999	Cabales et al.	2003/0084756 A1	5/2003	Schroder et al.
D412,544 S	8/1999	Burger			
5,935,027 A	8/1999	Nashif et al.			
5,943,767 A	8/1999	Milam			
5,944,617 A	8/1999	Falone et al.	CA	557838	5/1958
5,967,913 A	10/1999	Sulenta	CA	633295	12/1961
5,979,288 A	11/1999	Gallagher et al.	CA	903285	6/1972
5,980,404 A	11/1999	Gentile	CA	1043065	11/1978
5,980,674 A	11/1999	Burger	CA	1043379	11/1978
5,997,970 A	12/1999	You	CA	1047561	1/1979
6,001,035 A	12/1999	Roberts	CA	1063747	10/1979
6,004,900 A	12/1999	O'Brien, III	CA	1069147	1/1980
6,019,691 A	2/2000	Hillborn	CA	1072142	2/1980
6,033,326 A	3/2000	Lee	CA	1138912	1/1983
6,033,327 A	3/2000	Bird	CA	1145371	4/1983
6,033,328 A	3/2000	Bellefleur et al.	CA	1147767	6/1983
6,036,610 A	3/2000	Lewark	CA	1151693	8/1983
6,039,661 A	3/2000	Christian et al.	CA	1180728	1/1985
6,042,485 A	3/2000	Cheng	CA	1183883	3/1985
6,045,906 A	4/2000	McMahon et al.	CA	1187525	5/1985
6,062,995 A	5/2000	Murphy et al.	CA	1205835	6/1986
6,062,996 A	5/2000	Quigley	CA	1206309	6/1986
6,063,839 A	5/2000	Oosedo et al.	CA	1206497	6/1986
D430,249 S	8/2000	Burger	CA	1207350	7/1986
6,102,819 A	8/2000	Christian et al.	CA	1219886	3/1987
D431,273 S	9/2000	Burger	CA	1230898	12/1987
6,113,508 A	9/2000	Locarno et al.	CA	2071859 A1	6/1991
6,117,029 A	9/2000	Kunisaki et al.	CA	2029109 A1	2/1992
6,129,962 A	10/2000	Quigley et al.	CA	2037273 A1	8/1992
6,152,840 A	11/2000	Baum	CA	2066476 A1	10/1992
6,155,932 A	12/2000	Cabales et al.	CA	1310674	11/1992
6,176,640 B1	1/2001	Gonczy	CA	2071022 A1	12/1992
6,183,384 B1	2/2001	Roberto	CA	2099853 A1	7/1993
6,197,392 B1	3/2001	Jones	CA	2062635 A1	9/1993
6,203,447 B1	3/2001	Dillard	CA	2067087 A1	10/1993
6,203,454 B1	3/2001	Nashif et al.	CA	2105797 A1	11/1993
6,206,793 B1	3/2001	Burger	CA	1328892	4/1994
D440,617 S	4/2001	Goldsmith	CA	2081439 A1	4/1994
6,224,505 B1	5/2001	Burger	CA	2086470	4/1994
6,234,923 B1	5/2001	Gentile	CA	2125343 A1	7/1994
6,241,633 B1	6/2001	Conroy	CA	2088899 A1	8/1994
6,248,031 B1	6/2001	Brodie	CA	2120809 A1	10/1994
6,250,193 B1	6/2001	Head	CA	2096304	11/1994
6,257,997 B1	7/2001	Doble et al.	CA	2108069 A1	4/1995
6,265,475 B1	7/2001	Chifei et al.	CA	2132567 A1	7/1995
6,267,697 B1	7/2001	Sulenta	CA	2123248 A1	10/1995
6,273,829 B1	8/2001	Carlson	CA	2204021 A1	5/1996
6,273,835 B1	8/2001	Battis et al.	CA	2169216 A1	8/1996
6,274,230 B1	8/2001	Sarrelongue et al.	CA	2162444 A1	12/1996
6,306,474 B1	10/2001	Yoshioka et al.	CA	2226670 A1	2/1997
6,352,485 B1	3/2002	Philpot et al.	CA	2160731 A1	4/1997
6,358,166 B1	3/2002	Yu	CA	2164188 A1	5/1997
6,364,792 B1	4/2002	Evanochko	CA	2200663 A1	9/1997
6,364,793 B1	4/2002	Valarik	CA	2180893 A1	1/1998
6,395,210 B1	5/2002	Head et al.	CA	2223098	3/1998
D458,329 S	6/2002	Clark et al.	CA	2190431 A1	5/1998
6,399,199 B1	6/2002	Fujino et al.	CA	2228104 A1	9/1998
6,403,504 B1	6/2002	McMahon et al.	CA	2294864 A1	9/1998
6,500,079 B1	12/2002	Tucker	CA	2202454 A1	10/1998
6,515,081 B2	2/2003	Oosedo et al.	CA	2238291 A1	2/1999
6,525,125 B1	2/2003	Giardello et al.	CA	2244610 A1	2/1999
2001/0018378 A1	8/2001	Burger	CA	2262210 A1	8/1999
2001/0029813 A1	10/2001	Schroder	CA	2272497 A1	12/1999
2001/0041633 A1	11/2001	Tiitola	CA	2294301 A1	1/2000
2001/0046909 A1*	11/2001	Pagotto 473/563	CA	2310802 A1	2/2001
2001/0046910 A1	11/2001	Sutherland	CA	2289988 A1	5/2001
2002/0007022 A1	1/2002	Oosedo et al.	CA	2326966 A1	6/2001
2002/0061374 A1	5/2002	O'Brien	CA	2329228 A1	6/2001
2002/0073620 A1	6/2002	Lank	CA	2293950 A1	7/2001
2002/0094891 A1	7/2002	Horwood et al.	CA	2324063 A1	2/2002
2002/0098924 A1	7/2002	Houser et al.	CA	2357331 A1	3/2002
2002/0107095 A1	8/2002	Becker	DE	2359410 A1	4/2002
				376009	12/1921

FOREIGN PATENT DOCUMENTS

US 7,963,868 B2

Page 4

DE	3238117	A1	6/1983	WO	WO 93/05219	A1	3/1993
EP	0 172 564	A2	2/1986	WO	WO 94/21334	A1	9/1994
EP	0 172 564	A3	2/1986	WO	WO 94/23768	A1	10/1994
EP	0 226 420	A2	6/1987	WO	WO 95/01820	A1	1/1995
EP	0 226 420	A3	6/1987	WO	WO 95/24245	A1	9/1995
EP	0 226 420	B1	6/1987	WO	WO 96/01137	A1	1/1996
EP	0 310 203	A1	4/1989	WO	WO 96/01699	A1	1/1996
EP	0 351 201	A2	1/1990	WO	WO 96/02385	A1	2/1996
EP	0 407 996	A2	1/1991	WO	WO 96/13549	A2	5/1996
EP	0 407 996	A3	1/1991	WO	WO 97/03730	A1	2/1997
EP	0 407 996	B1	1/1991	WO	WO 97/03820	A1	2/1997
EP	0 441 971	A1	8/1991	WO	WO 97/29808	A1	8/1997
EP	0 441 971	B1	8/1991	WO	WO 97/33660	A1	9/1997
EP	0 441 971	B2	8/1991	WO	WO 97/41929	A2	11/1997
EP	0 487 549	B1	6/1992	WO	WO 98/01189	A1	1/1998
EP	0 504 230	B1	9/1992	WO	WO 98/19753	A1	5/1998
EP	0 523 913	A1	1/1993	WO	WO 98/24616	A1	6/1998
EP	0 532 444	A1	3/1993	WO	WO 98/41292	A1	9/1998
EP	0 585 965	A1	3/1994	WO	WO 98/55182	A2	12/1998
EP	0 597 166	A2	5/1994	WO	WO 99/17845	A1	4/1999
EP	0 597 166	A3	5/1994	WO	WO 99/32198	A1	7/1999
EP	0 597 166	B1	5/1994	WO	WO 99/60030	A1	11/1999
EP	0 662 391	A2	7/1995	WO	WO 00/03769	A1	1/2000
EP	0 662 391	A3	7/1995	WO	WO 00/09222	A2	2/2000
EP	0 733 469	A2	9/1996	WO	WO 00/10655	A1	3/2000
EP	0 733 469	A3	9/1996	WO	WO 00/27632	A1	5/2000
EP	0 733 469	B1	9/1996	WO	WO 00/32278	A1	6/2000
EP	0 742 266	A2	11/1996	WO	WO 00/46255	A1	8/2000
EP	0 742 266	A3	11/1996	WO	WO 01/14019	A1	3/2001
EP	0 764 453	A1	3/1997	WO	WO 01/26752	A1	4/2001
EP	0 927 628	A1	7/1999	WO	WO 01/43838	A1	6/2001
EP	0 947 562	A1	10/1999	WO	WO 01/47605	A2	7/2001
EP	0 970 708	A1	1/2000	WO	WO 01/97990	A2	12/2001
EP	0 693 944	B1	4/2000	WO	WO 02/04078	A1	1/2002
EP	1 068 884	A2	1/2001	WO	WO 02/13638	A2	2/2002
EP	1 086 724	A1	3/2001	WO	WO 02/35184	A2	5/2002
FI	65018		11/1983	WO	WO 02/070080	A1	9/2002
GB	637779		5/1950	WO	WO 02/089926	A1	11/2002
GB	1121051		7/1968	WO	WO 2005/082470	A1	9/2005
SE	169928		12/1959				
WO	WO 82/03789	A1	11/1982				
WO	WO 90/15712	A1	12/1990				
WO	WO 91/08803	A1	6/1991				
WO	WO 91/16955	A1	11/1991				

OTHER PUBLICATIONS

The Rubber Group Materials, Aug. 31, 2004, 4 pages from website.*

* cited by examiner

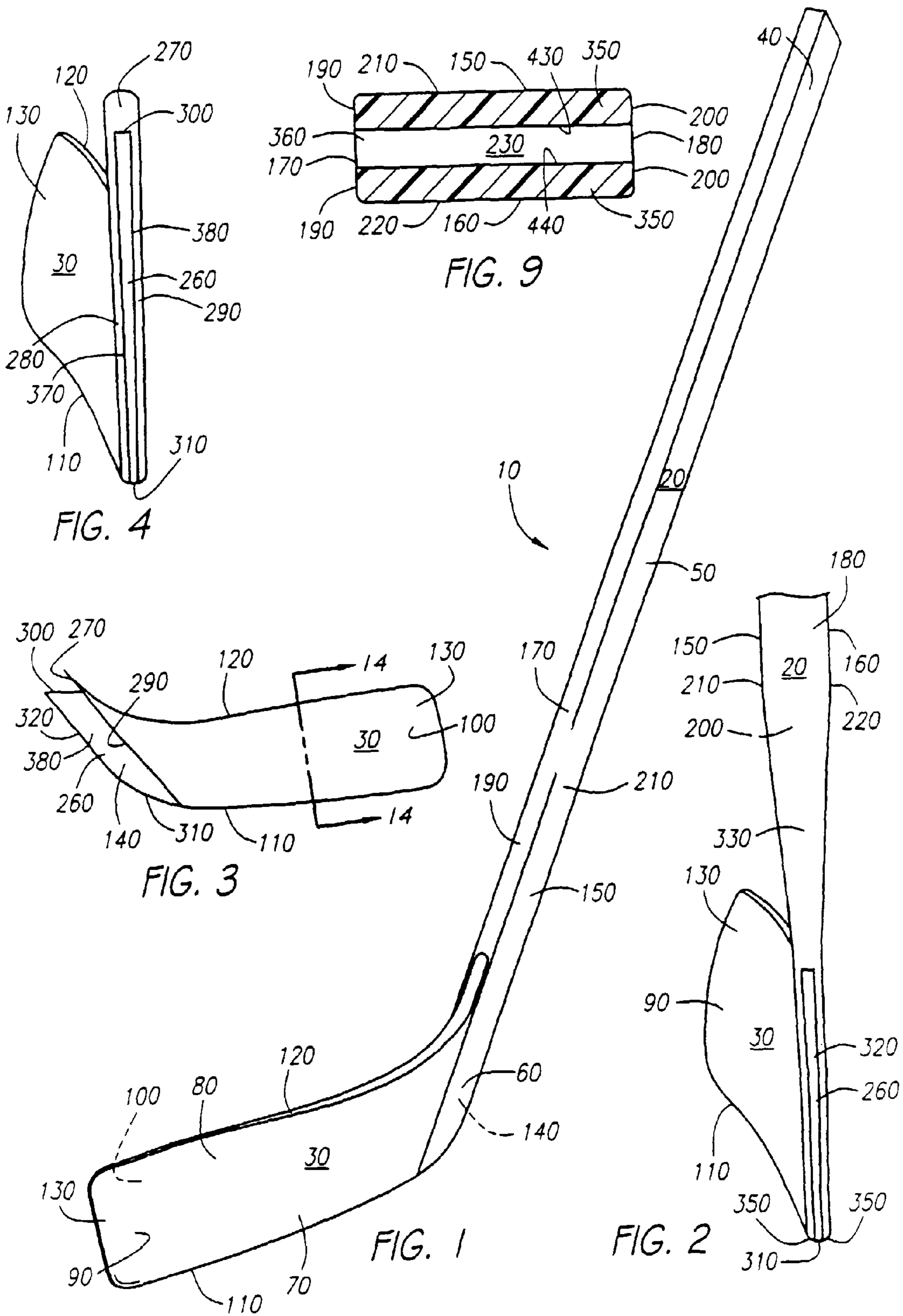

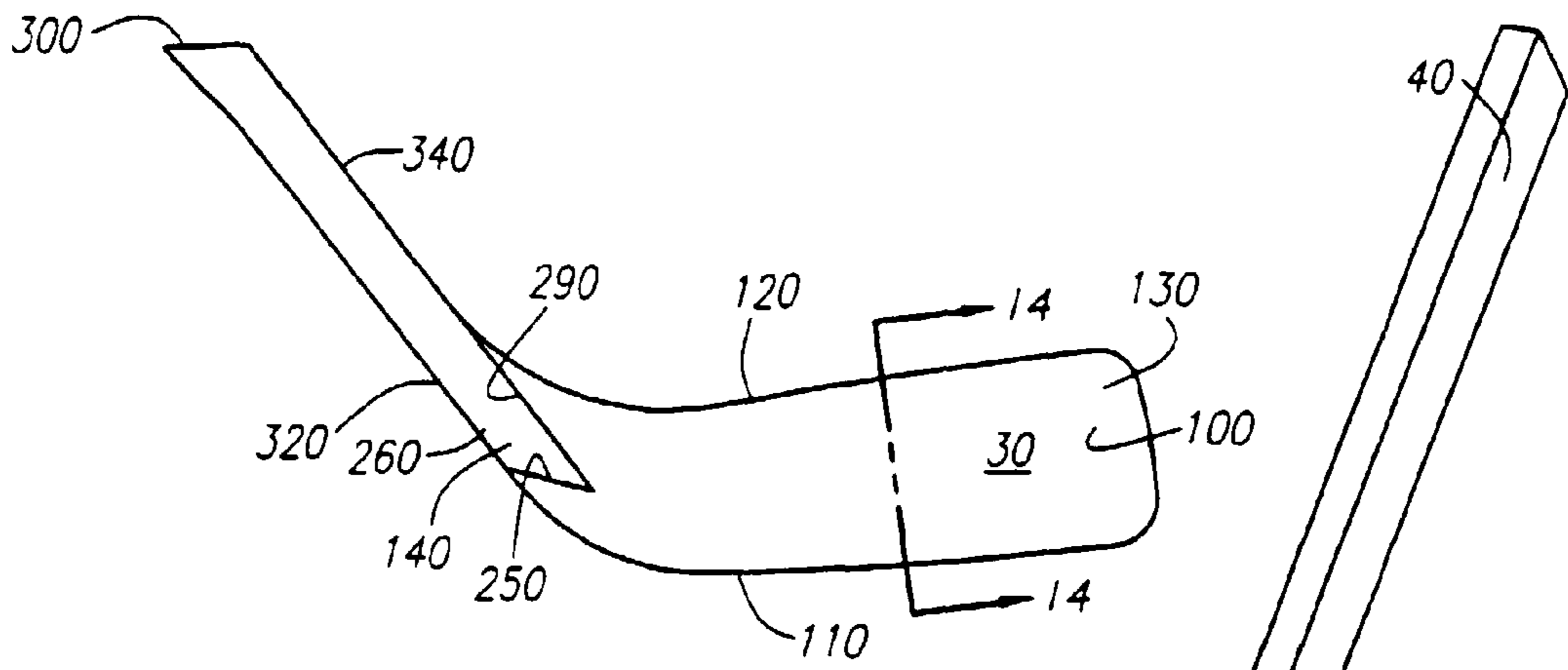

FIG. 7

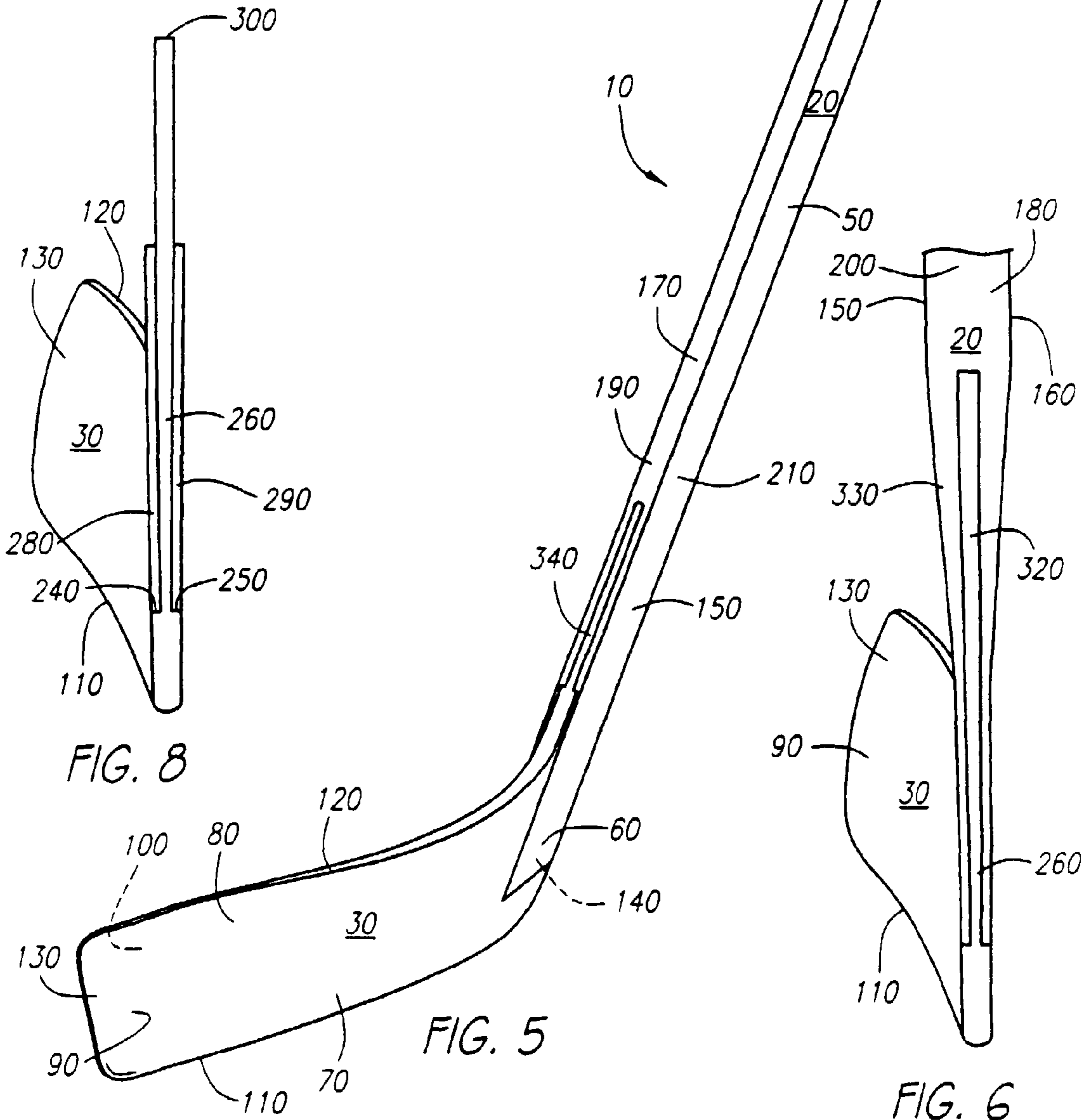
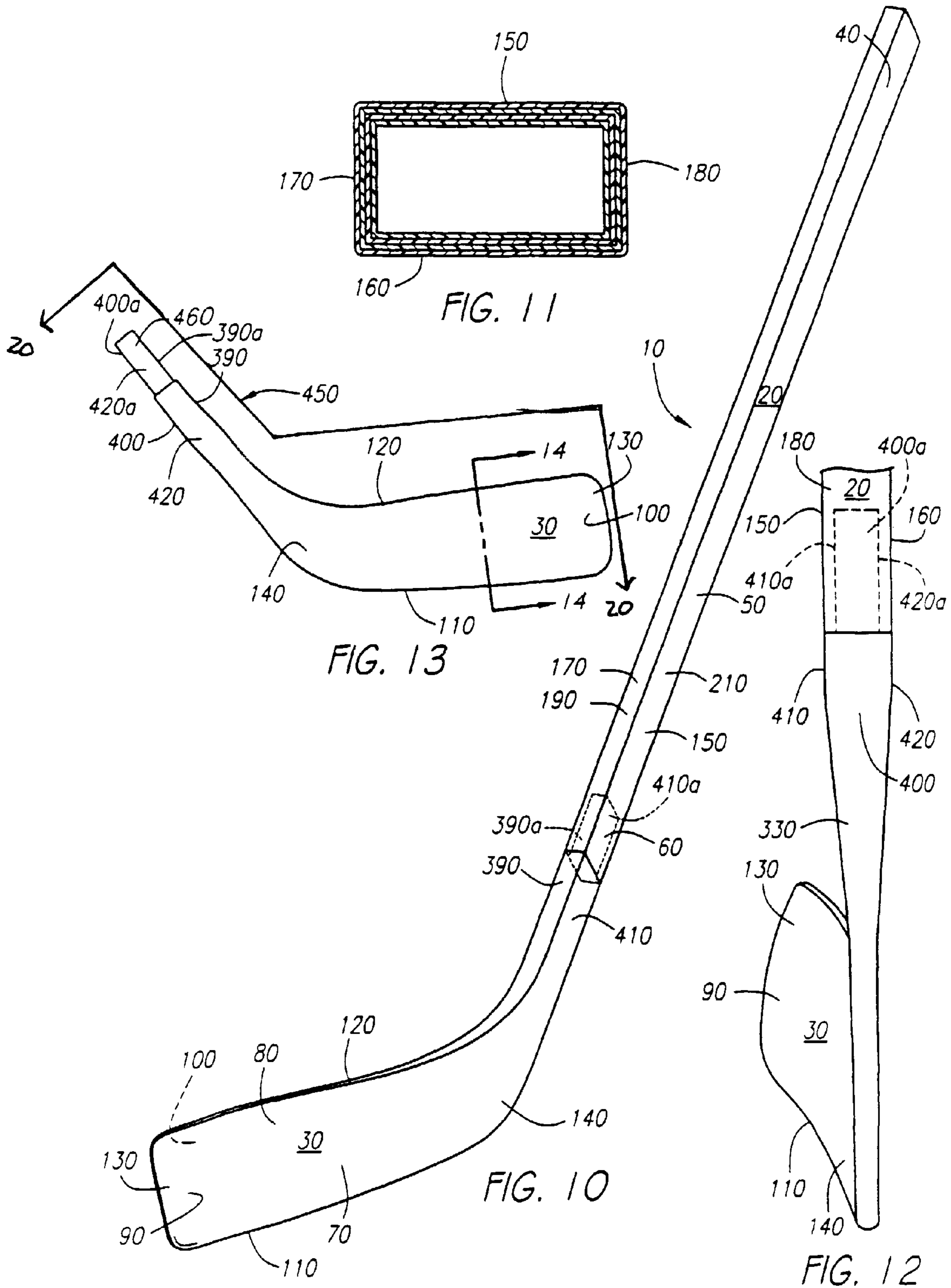

FIG. 8

FIG. 5

FIG. 6



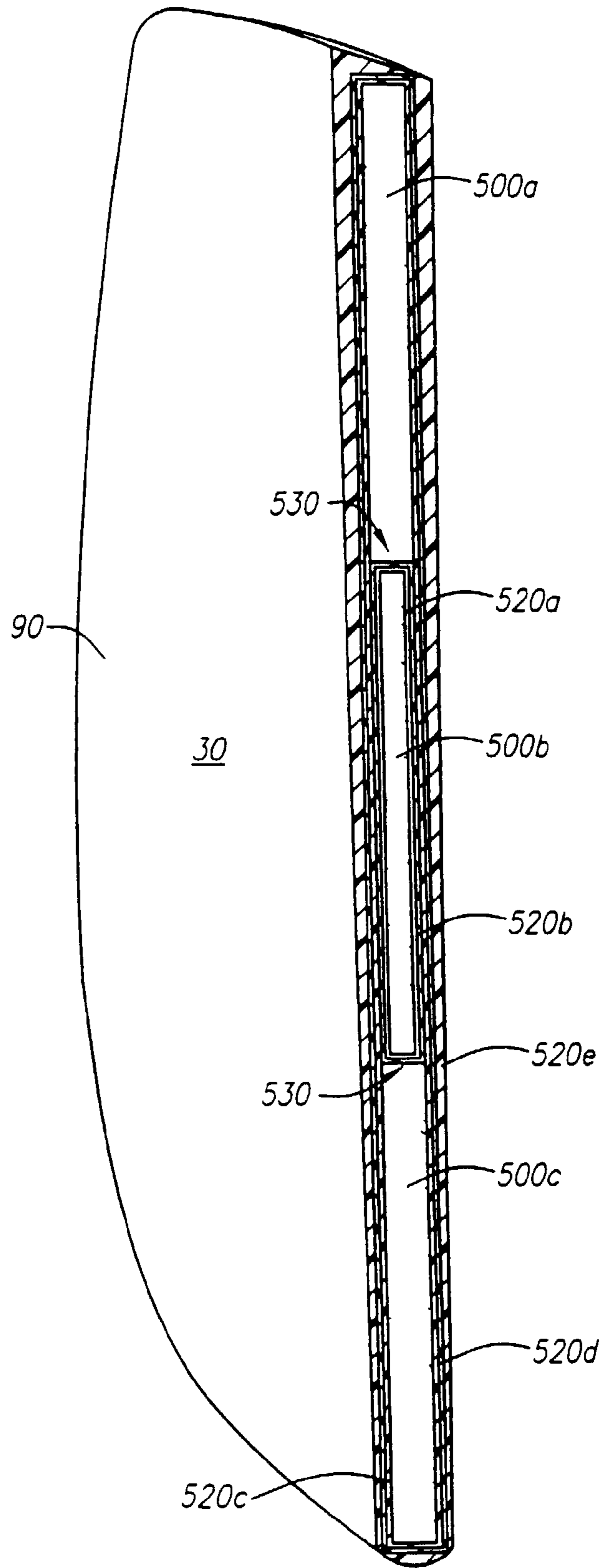

FIG. 14A

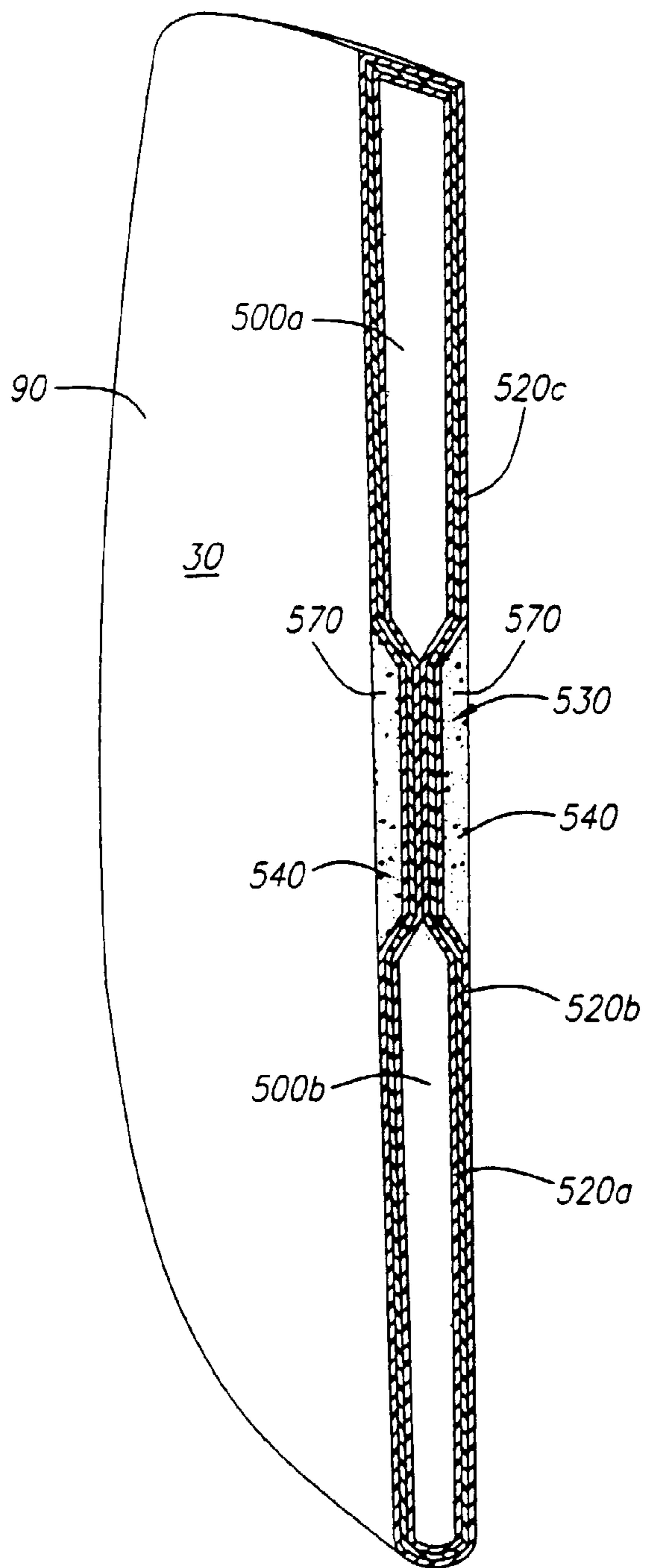

FIG. 14B

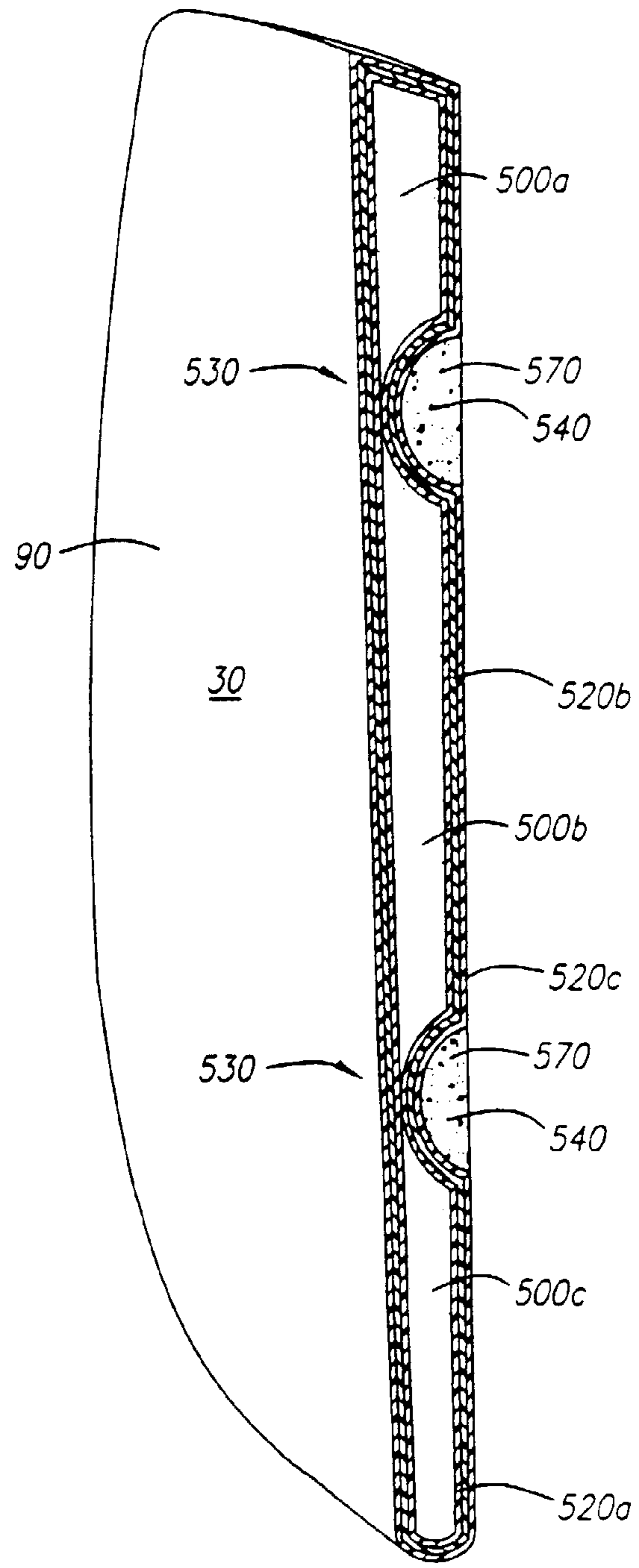

FIG. 14C

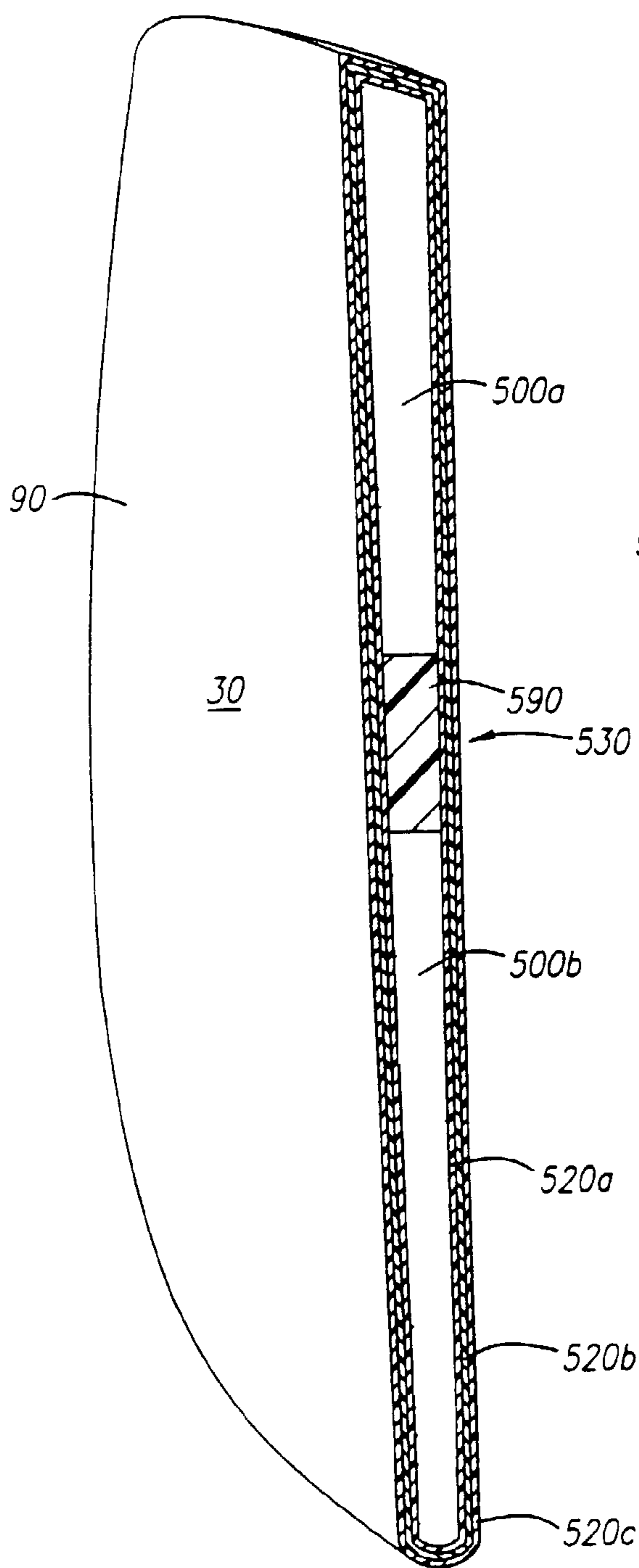

FIG. 14D

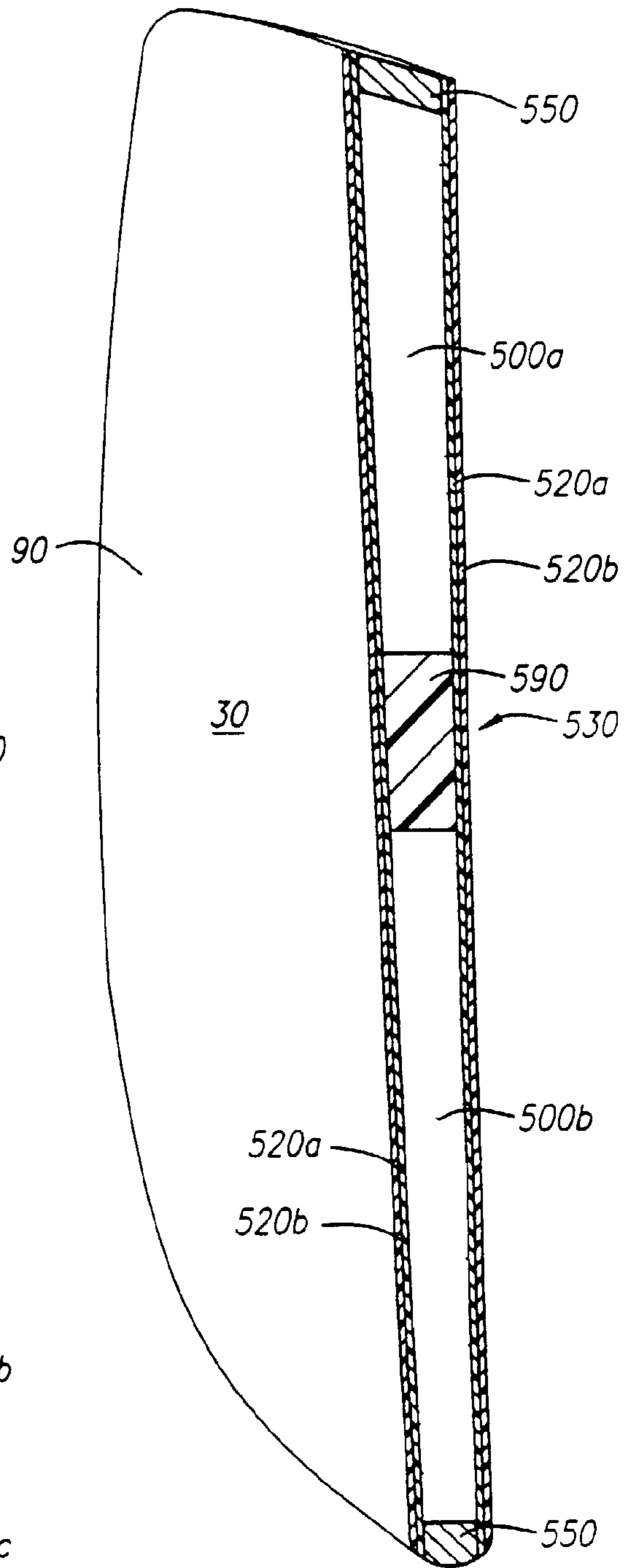

FIG. 14F

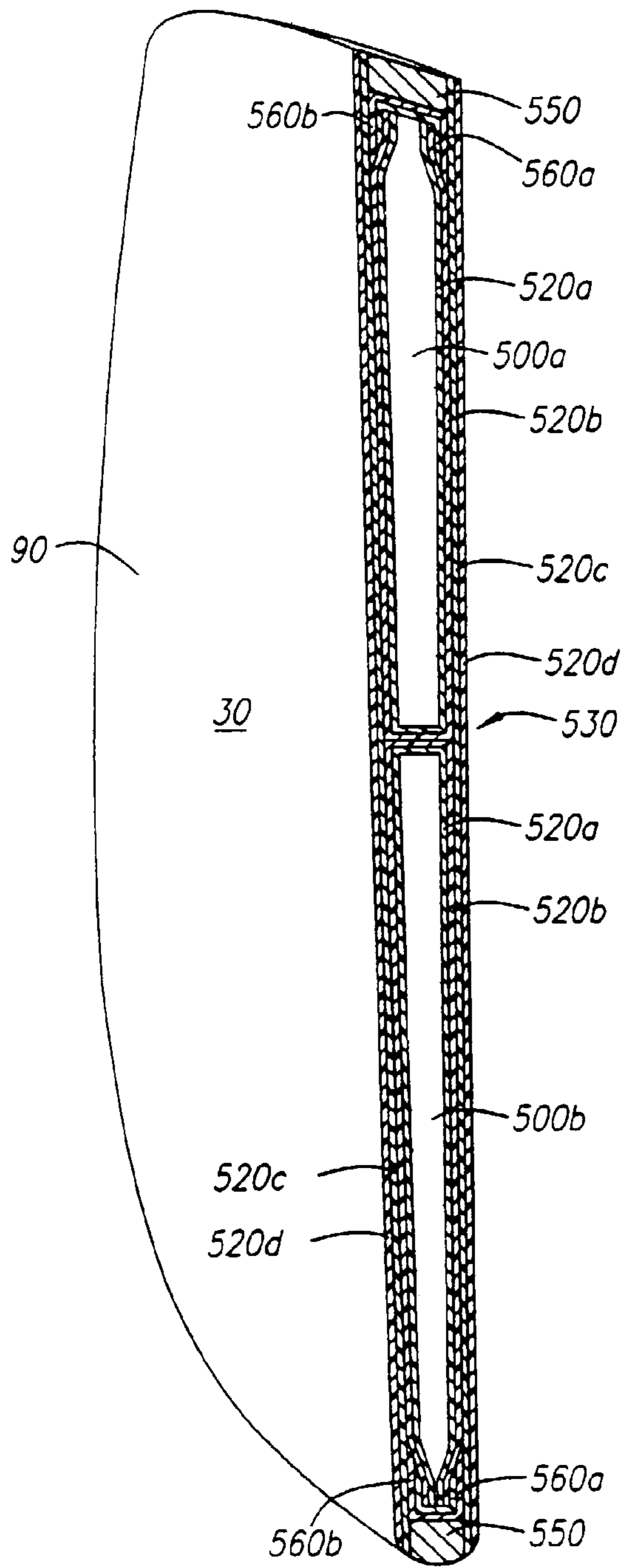

FIG. 14E

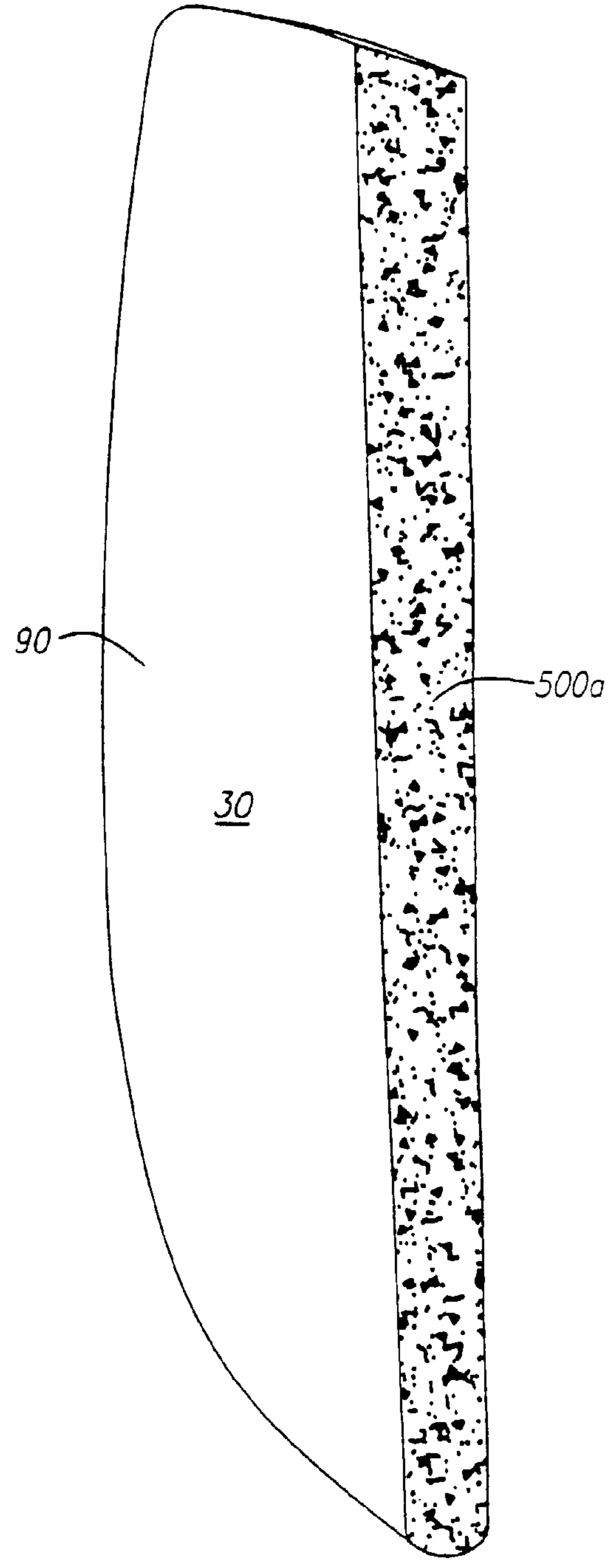

FIG. 14K

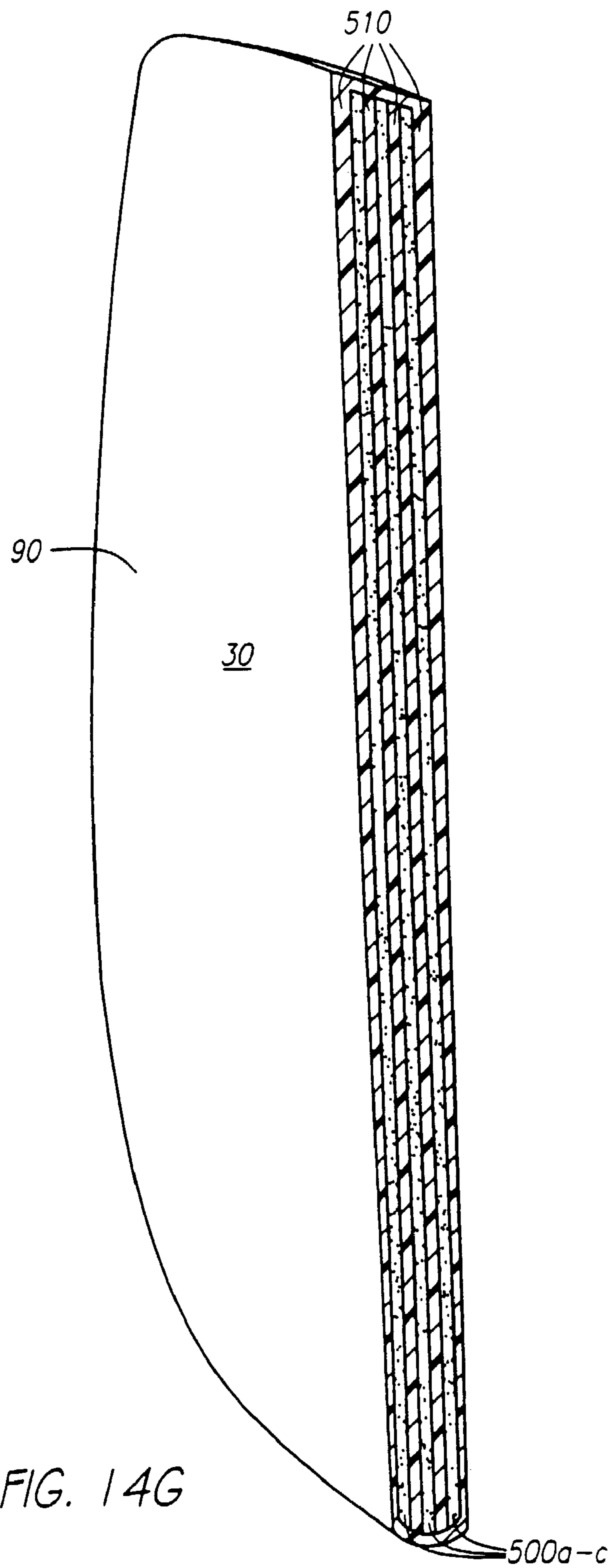

FIG. 14G

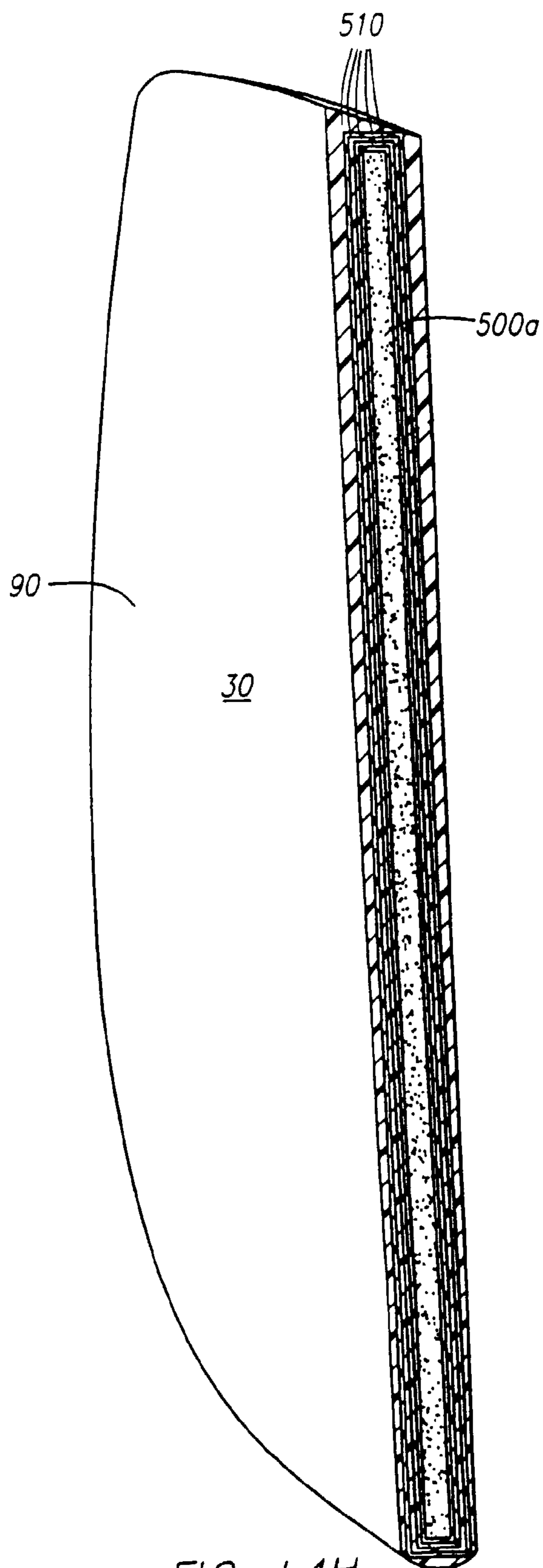

FIG. 14H

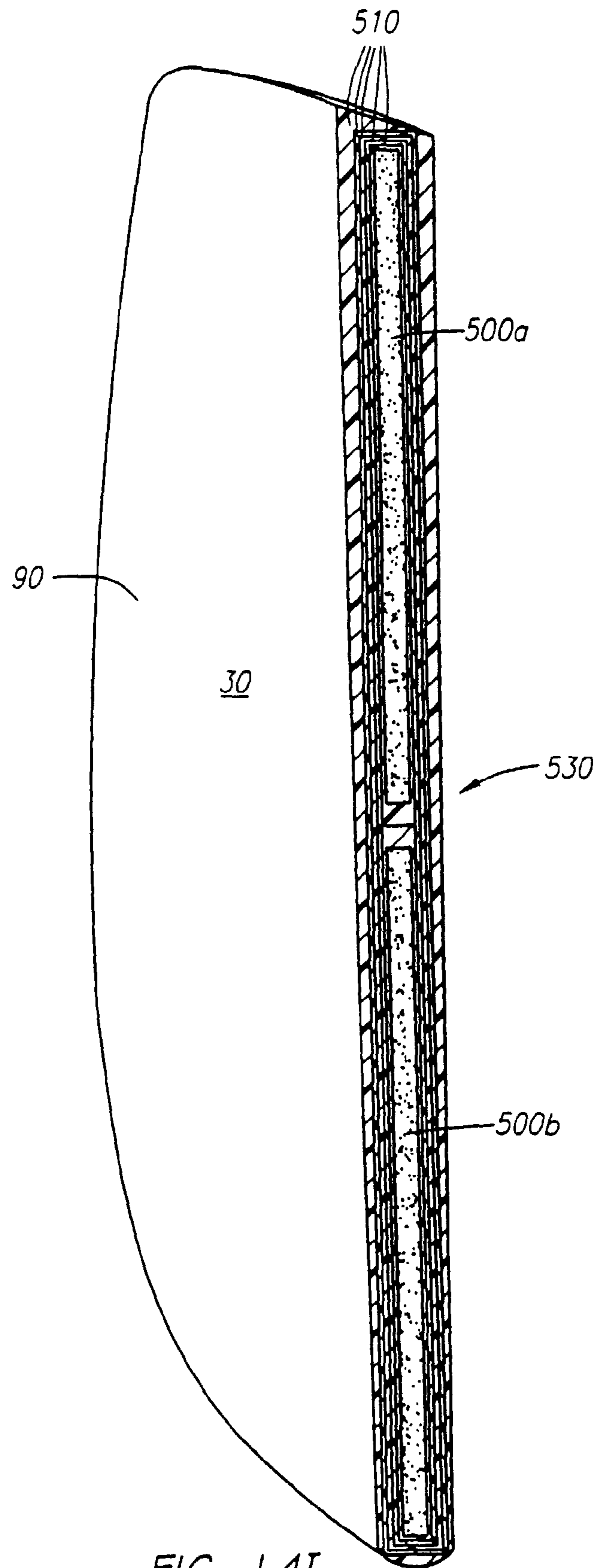

FIG. 14I

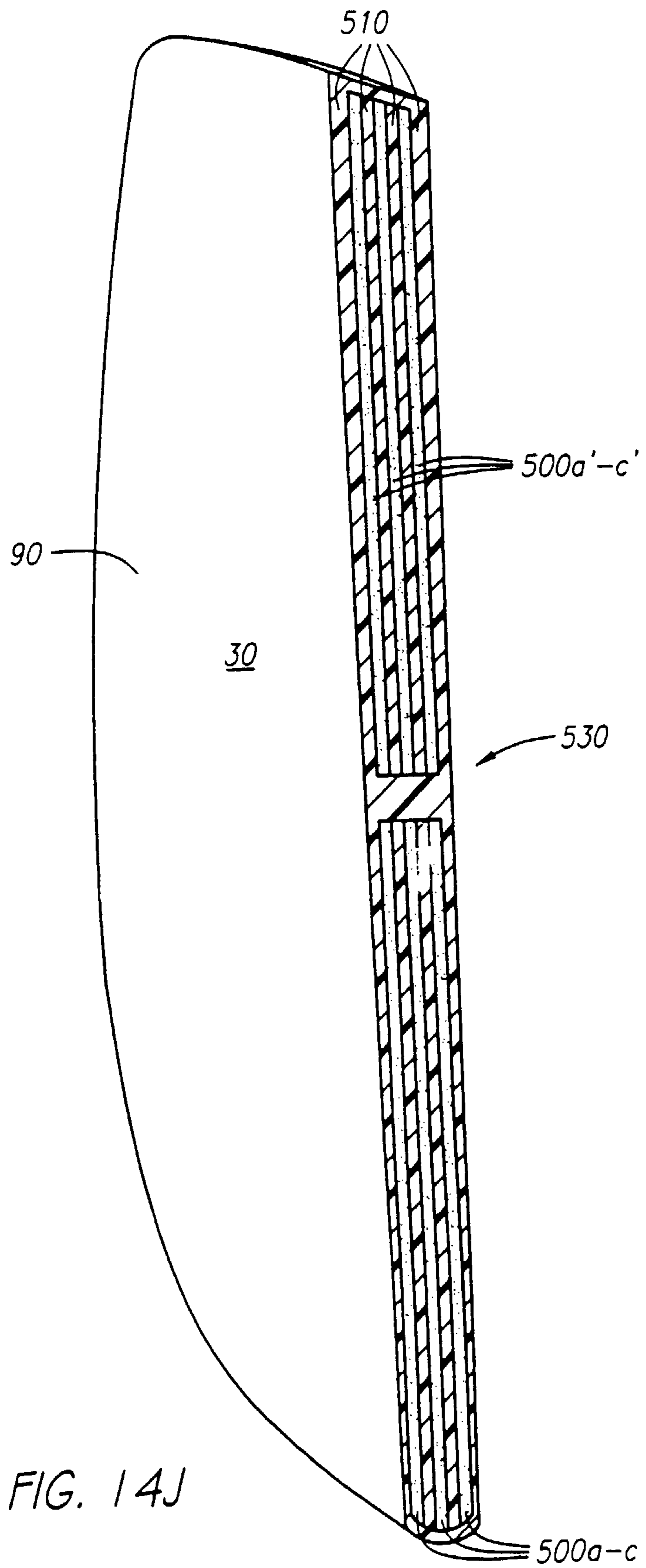

FIG. 14J

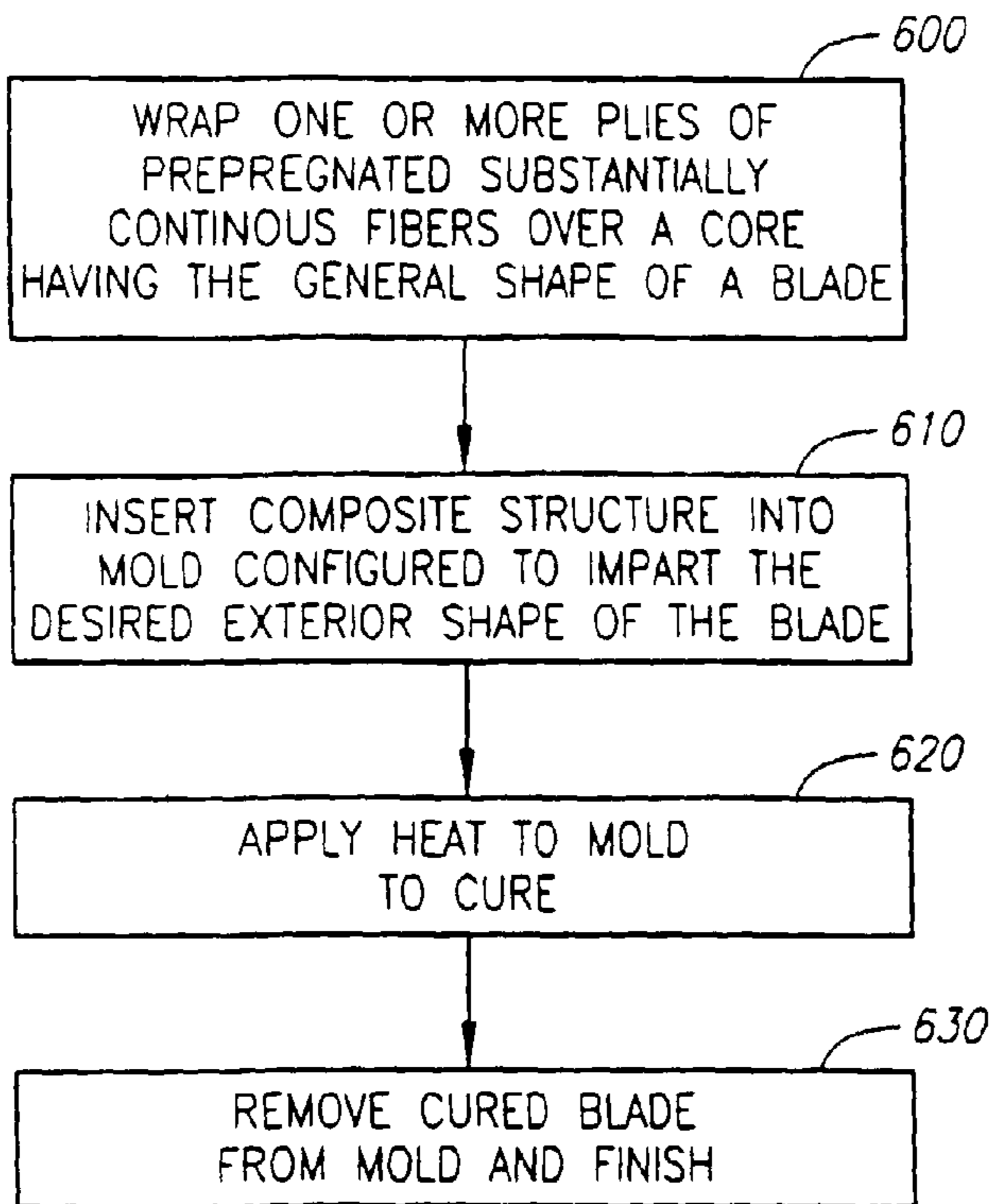

FIG. 15A

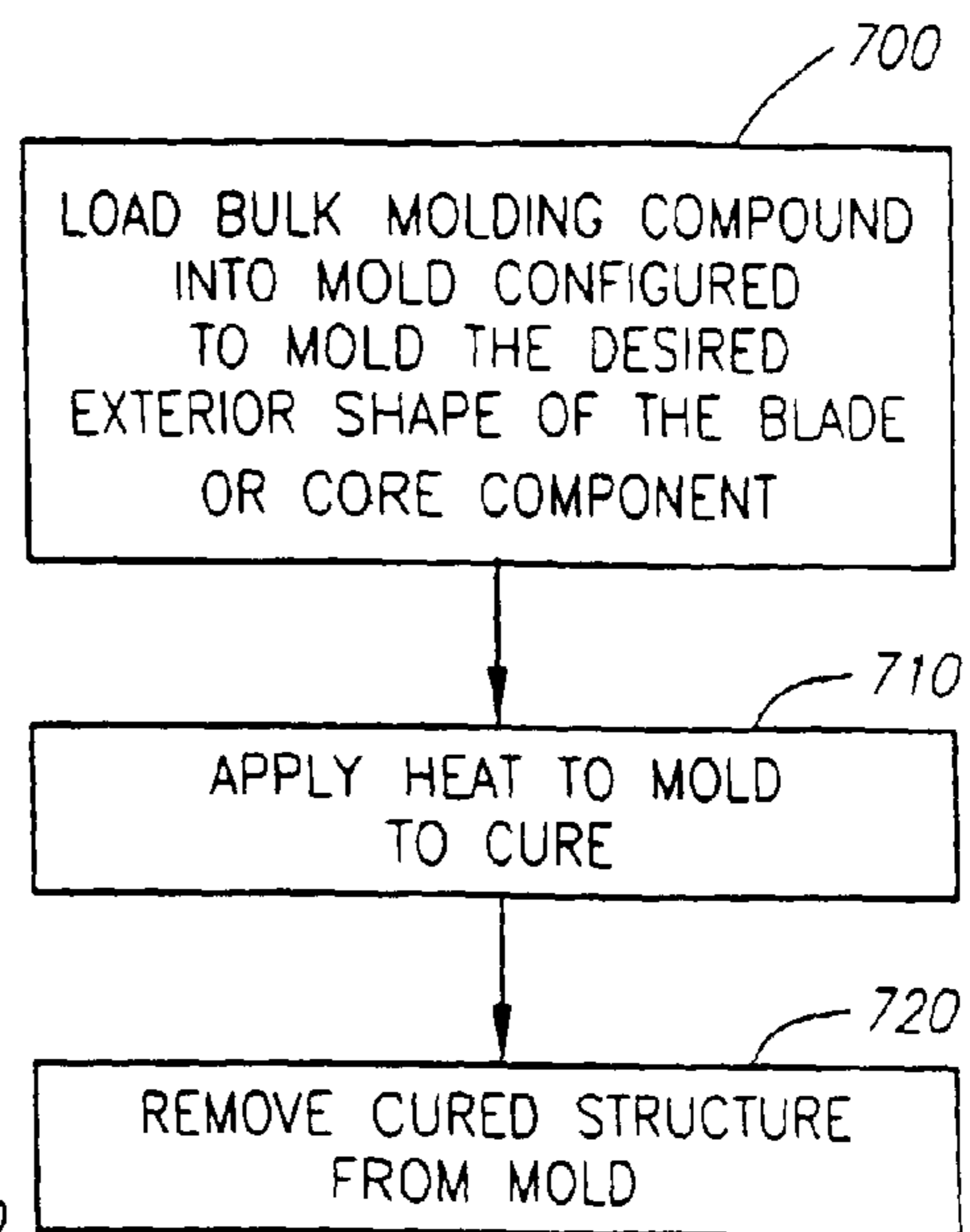

FIG. 15B

FIG. 16

FIG. 16A
FIG. 16B
FIG. 16C

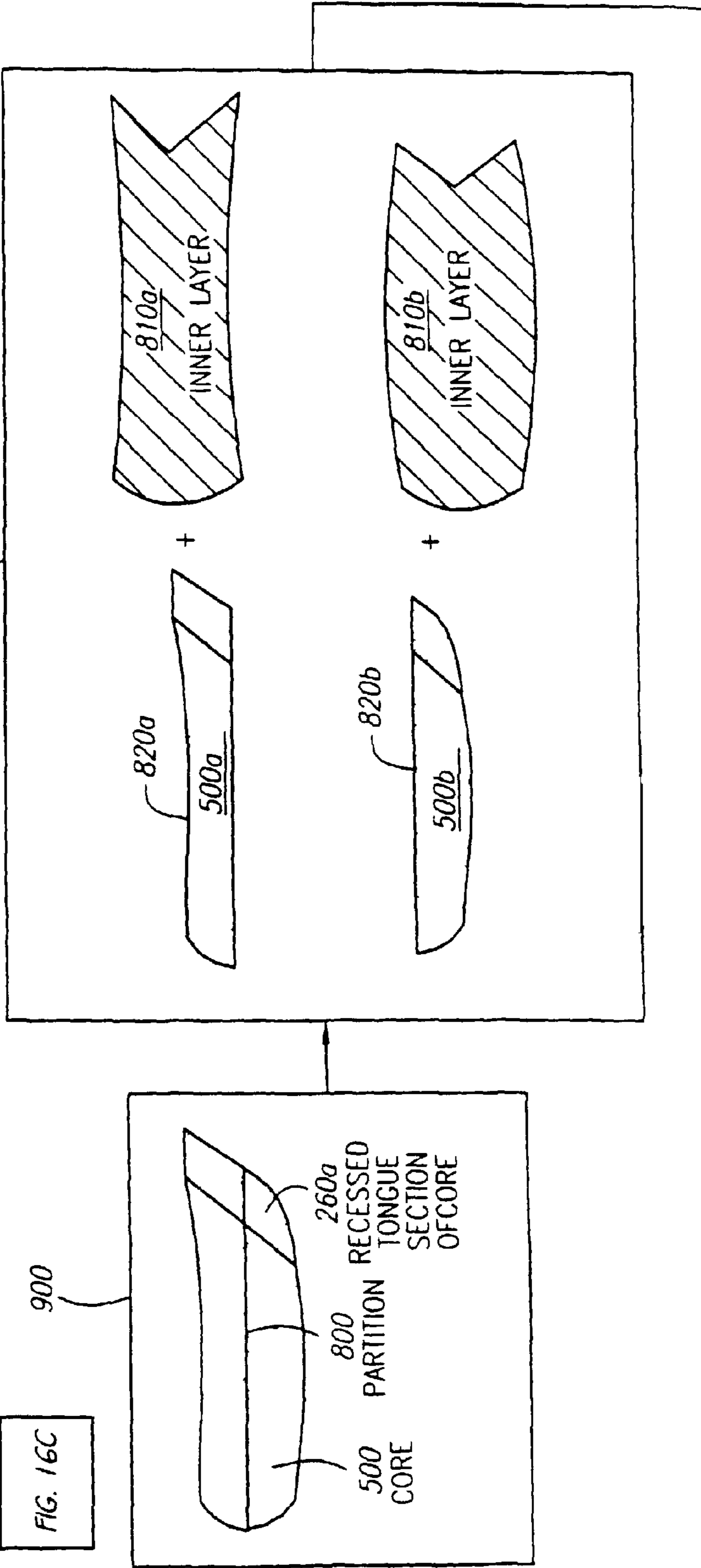

FIG. 16A

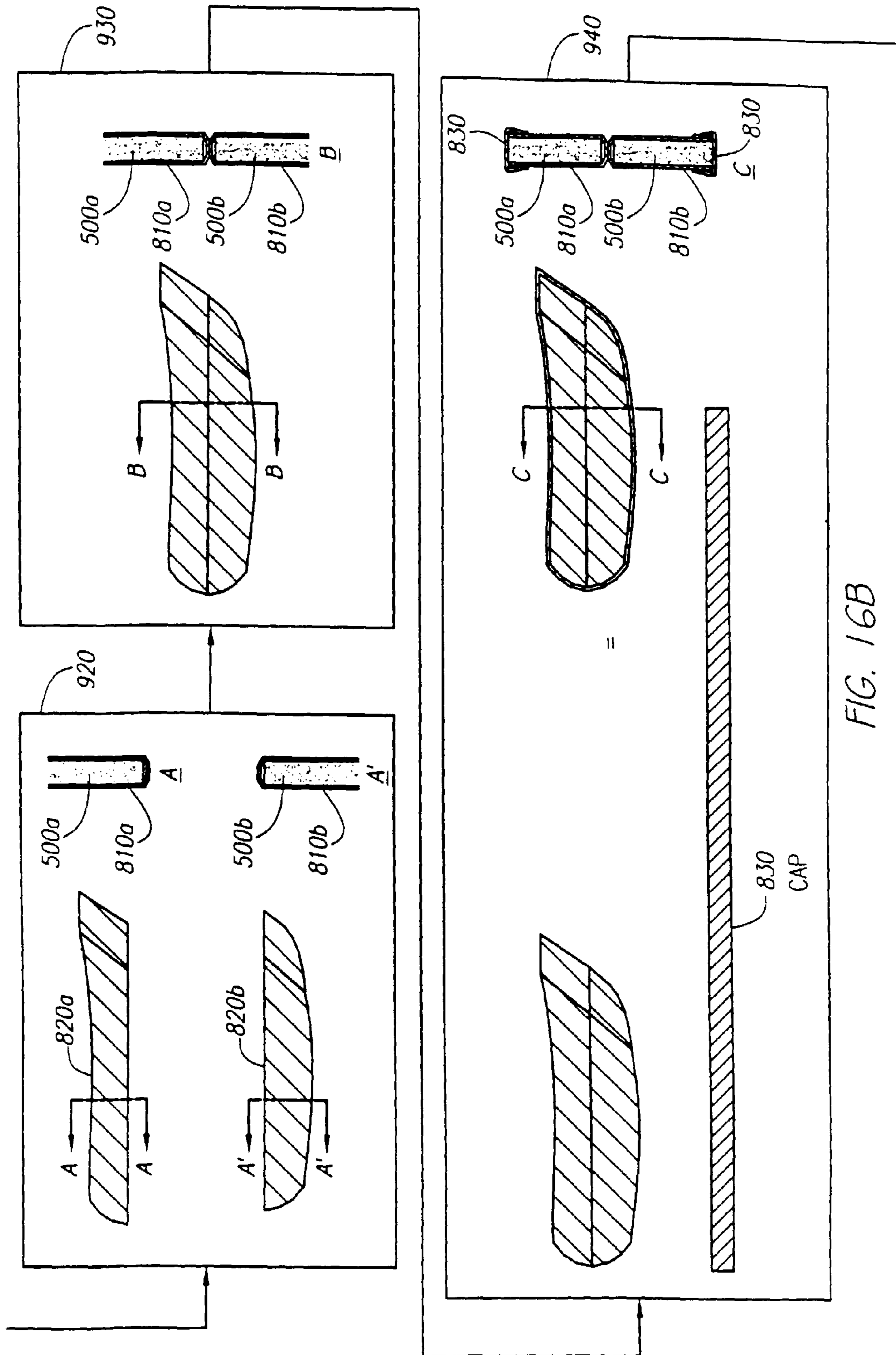

FIG. 16B

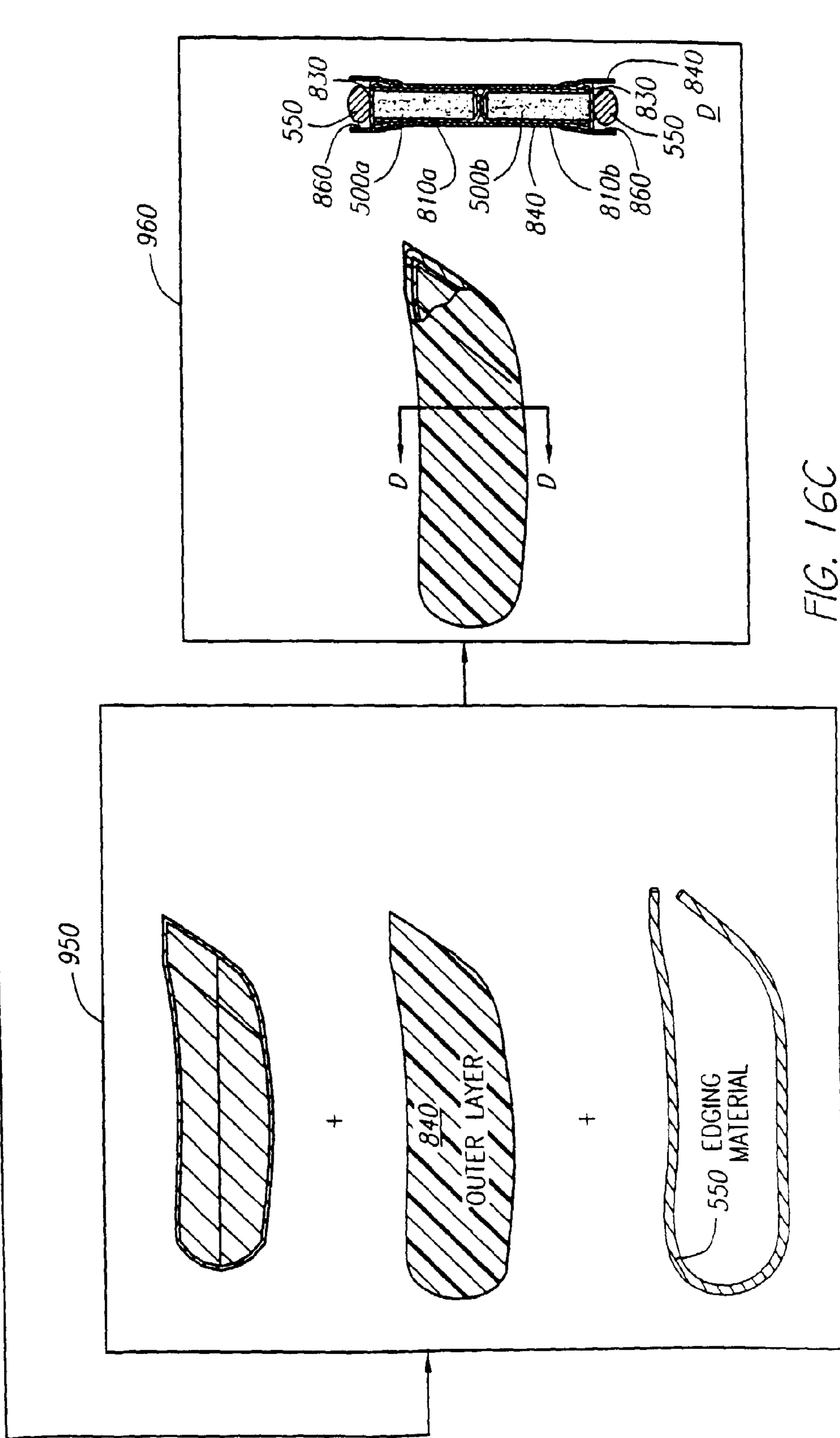
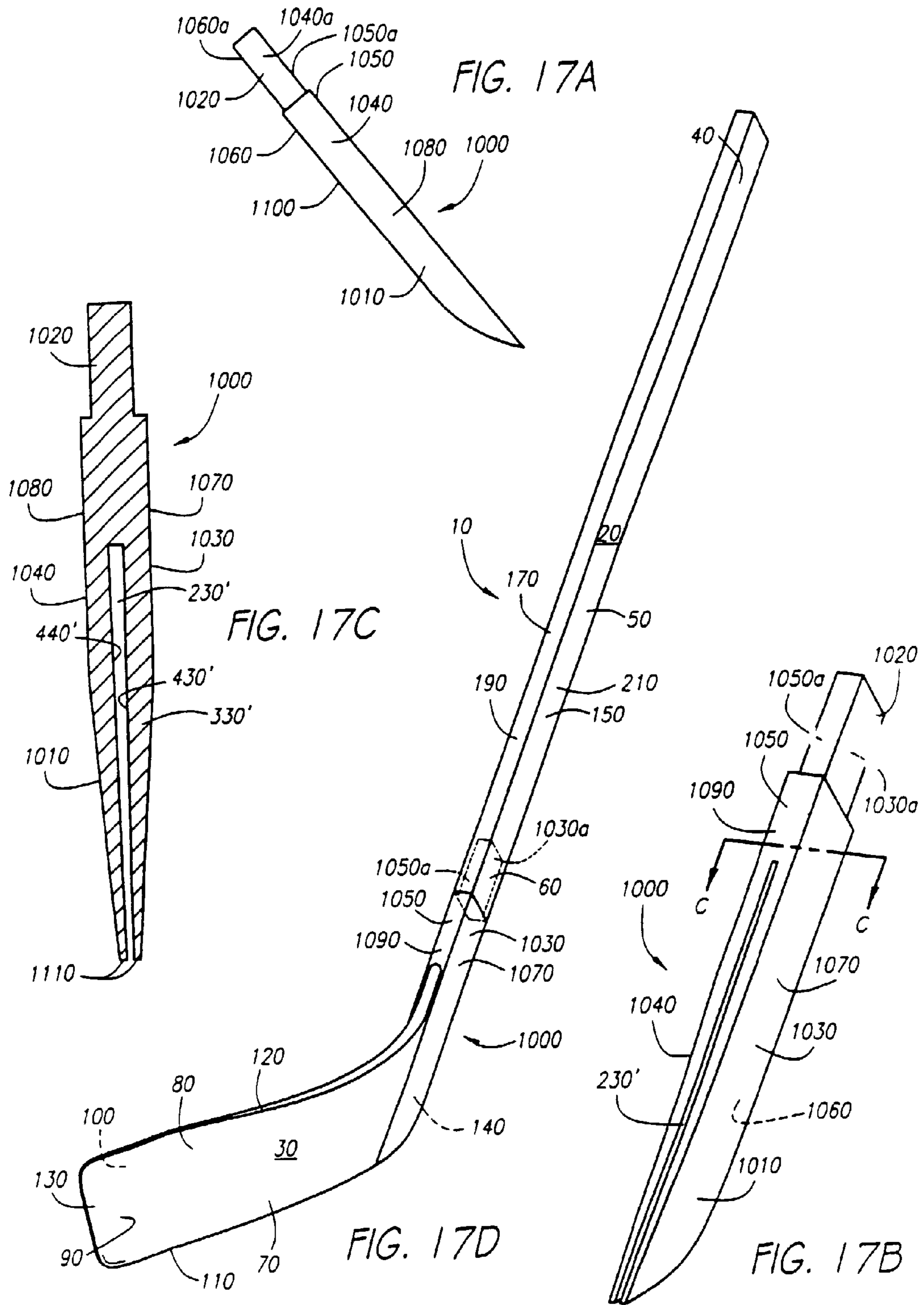

FIG. 16C



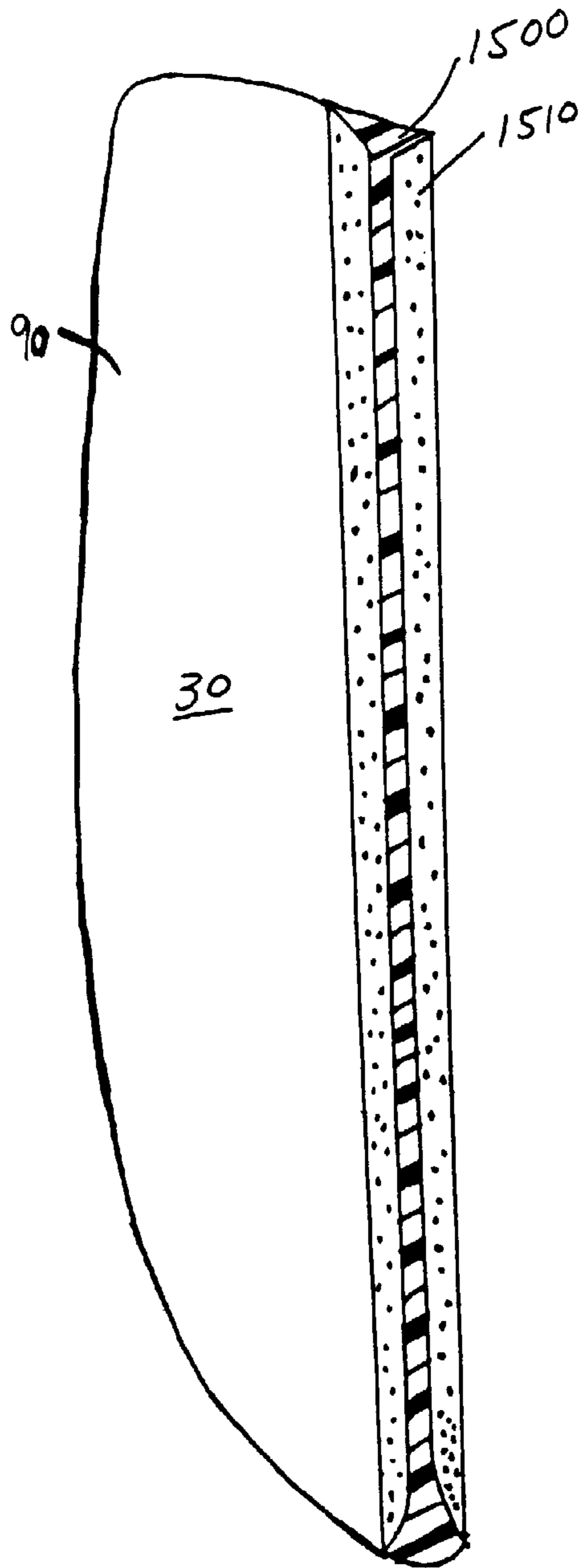

FIG. 18A

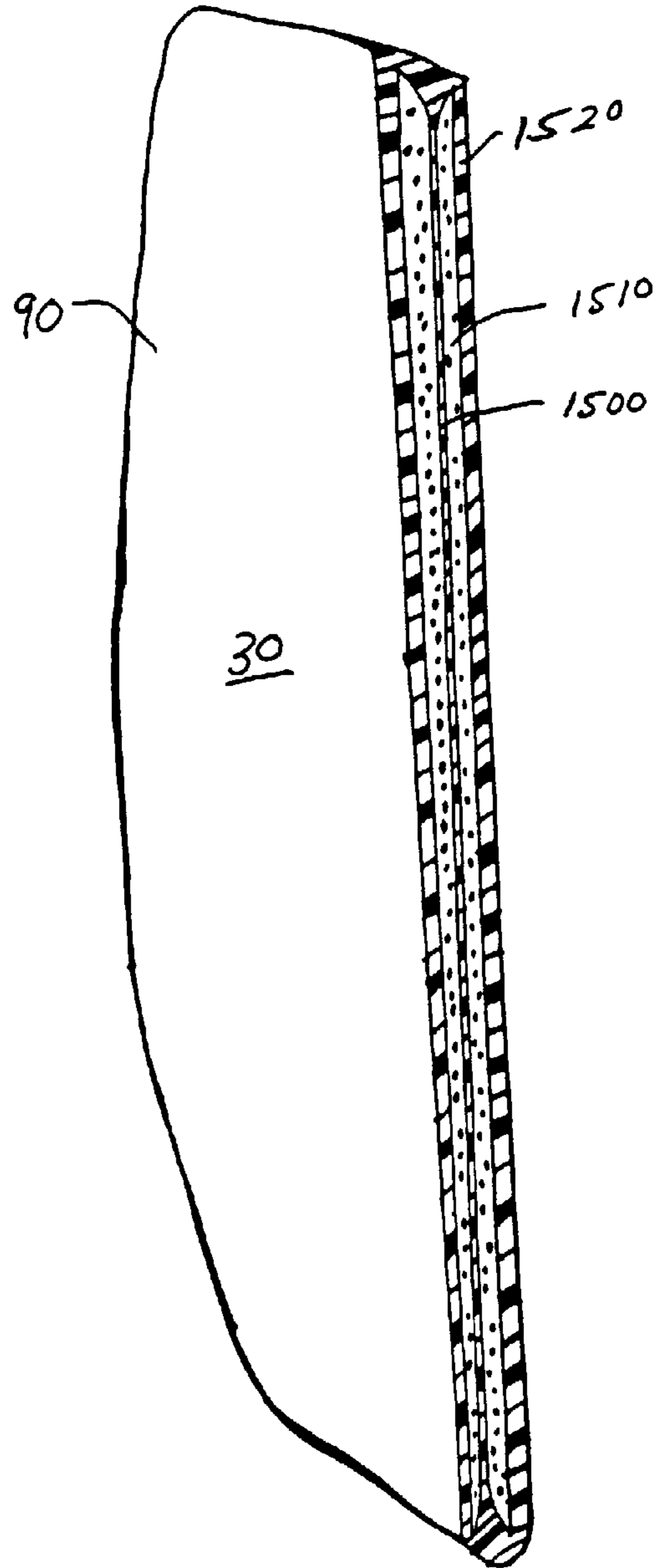

FIG. 18B

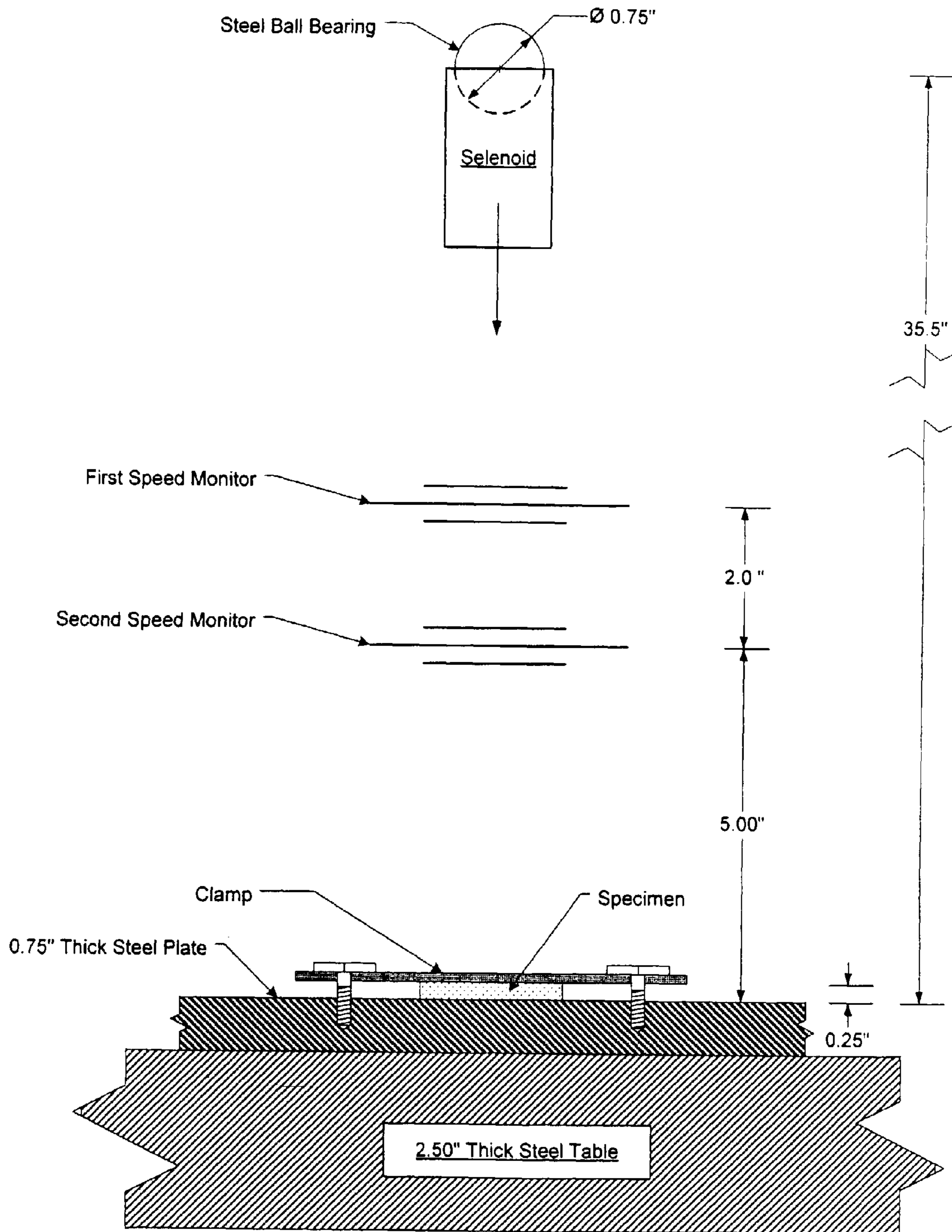

FIG. 19A

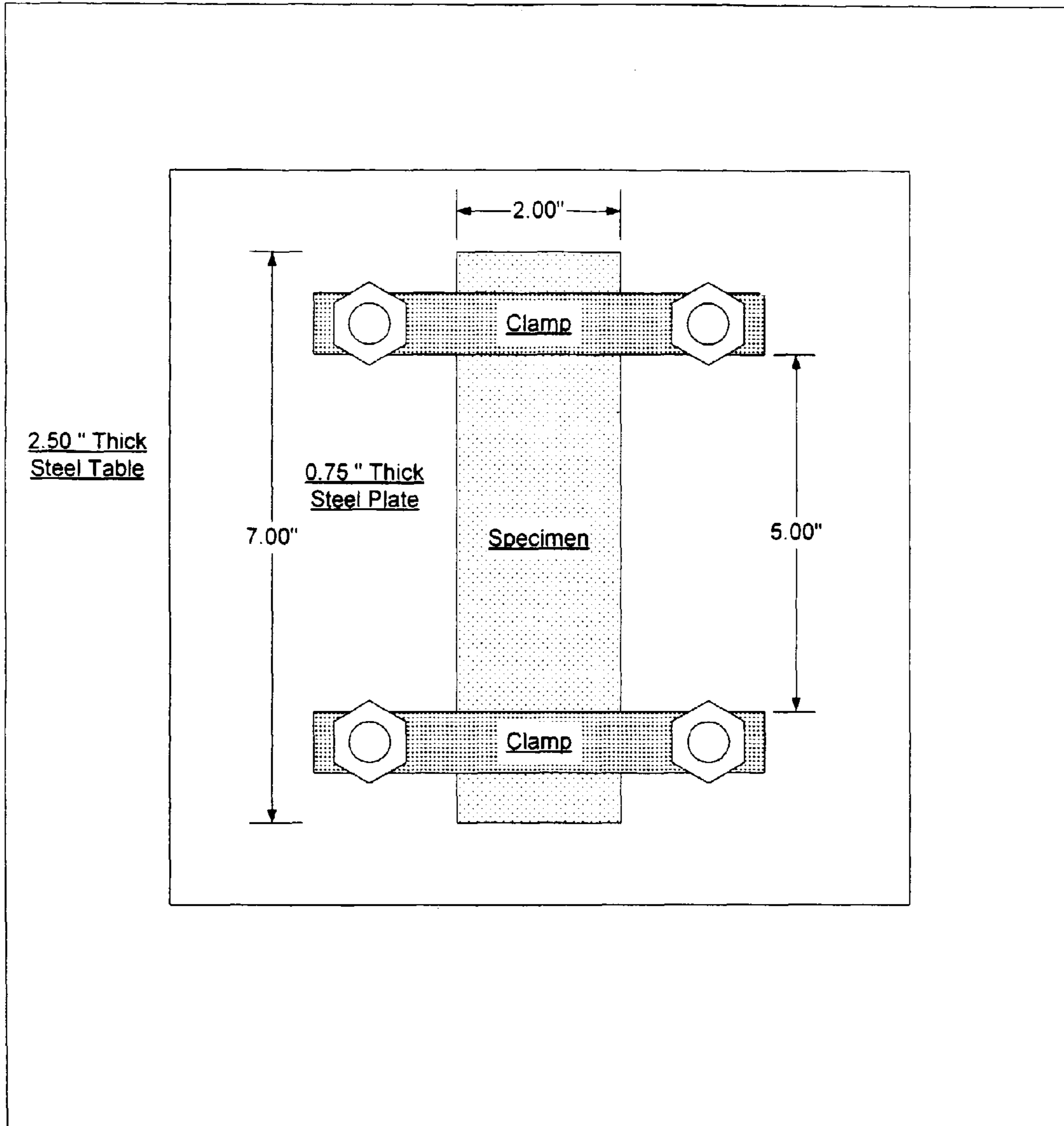

FIG. 19B

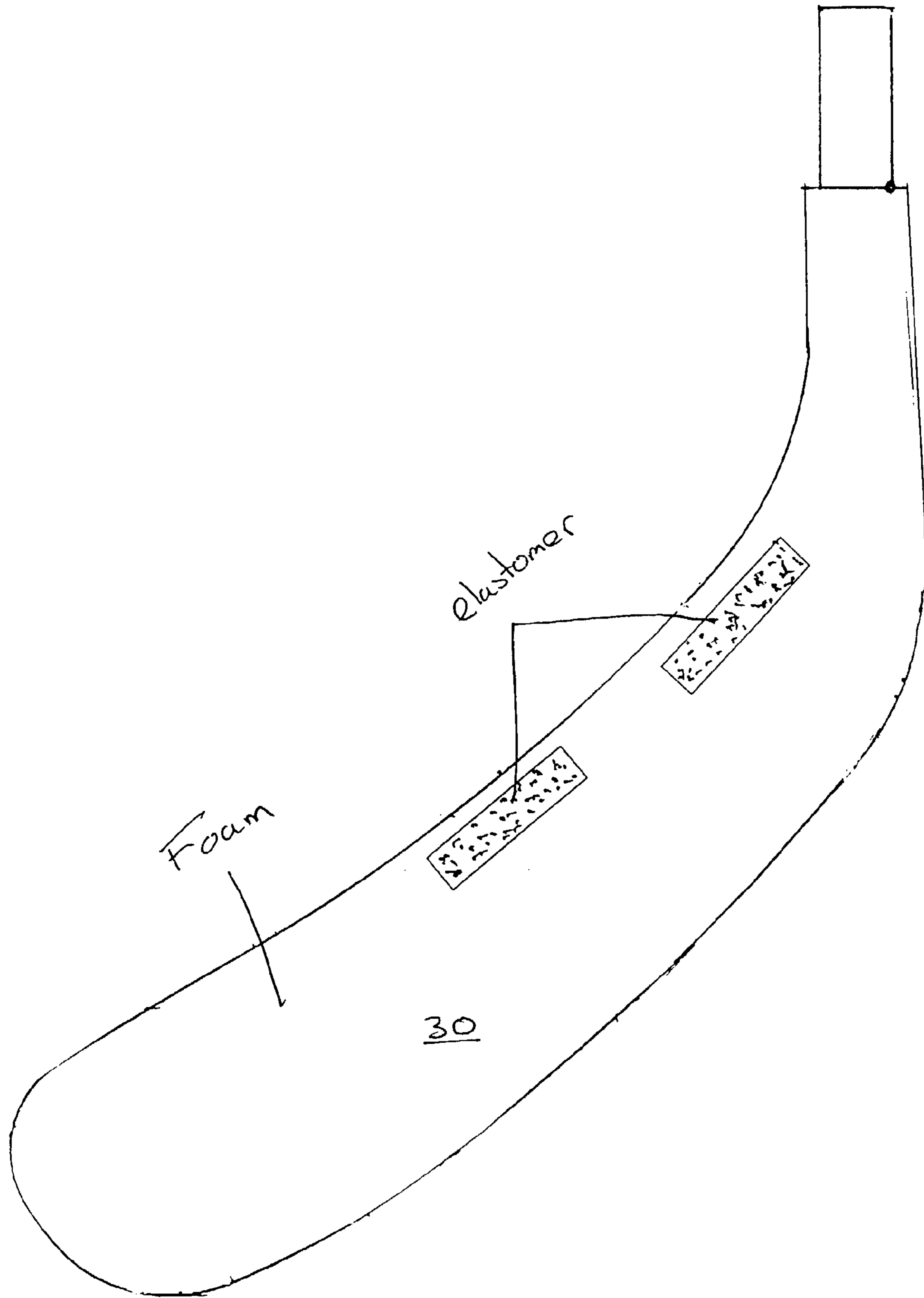

FIG. 20

HOCKEY STICK

RELATED APPLICATIONS

This application is a continuation-in-part of U.S. patent application Ser. No. 10/290,052 filed on Nov. 6, 2002 now abandoned which is a continuation of U.S. patent application Ser. No. 09/663,598 filed on Sep. 15, 2000 now abandoned. This application, also claims the benefit of priority of U.S. Provisional Application Ser. No. 60/380,900 filed on May 15, 2002 and U.S. Provisional Application Ser. No. 60/418,067 filed on Oct. 11, 2002, the contents of which are hereby incorporated by reference.

FIELD OF THE INVENTION

The field of the present invention generally relates to hockey sticks and component structures, configurations, and combinations thereof.

BACKGROUND OF THE INVENTION

Generally, hockey sticks are comprised of a blade portion and an elongated shaft portion. Traditionally, each portion was constructed of wood (e.g., solid wood, wood laminates) and attached together at a permanent joint. The joint generally comprised a slot formed by two opposing sides of the lower end section of the shaft with the slot opening on the forward facing surface of the shaft. As used in this application “forward facing surface of the shaft” means the surface of the shaft that faces generally toward the tip of the blade and is generally perpendicular to the longitudinal length of the blade at the point of attachment. The heel of the blade comprised a recessed portion dimensioned to be receivable within the slot. Upon insertion of the blade into the slot, the opposing sides of the shaft that form the slot overlap the recessed portion of the blade at the heel. The joint was made permanent by application of a suitable bonding material or glue between the shaft and the blade. In addition, the joint was oftentimes further strengthened by an overlay of fiberglass material.

Traditional wood hockey stick constructions, however, are expensive to manufacture due to the cost of suitable wood and the manufacturing processes employed. In addition, due to the wood construction, the weight may be considerable. Moreover, wood sticks lacked durability, often due to fractures in the blade, thus requiring frequent replacement. Furthermore, due to the variables relating to wood construction and manufacturing techniques, wood sticks were often difficult to manufacture to consistent tolerances. For example, the curve and flex of the blade often varied even within the same model and brand of stick. Consequently, a player after becoming accustomed to a particular wood stick was often without a comfortably seamless replacement when the stick was no longer in a useable condition.

Notwithstanding, the “feel” of traditional wood-constructed hockey sticks was found desirable by many players. The “feel” of a hockey stick can vary depending on a myriad of objective and subjective factors including the type of construction materials employed, the structure of the components, the dimensions of the components, the rigidity or bending stiffness of the shaft and/or blade, the weight and balance of the shaft and/or blade, the rigidity and strength of the joint(s) connecting the shaft to the blade, the curvature of the blade, the sound that is made when the blade strikes the puck, etc. Experienced players and the public are often inclined to use hockey sticks that have a “feel” that is comfortable yet provides the desired performance. Moreover, the subjective

nature inherent in this decision often results in one hockey player preferring a certain “feel” of a particular hockey stick while another hockey player prefers the “feel” of another hockey stick.

Perhaps due to the deficiencies relating to traditional wood hockey stick constructions, contemporary hockey stick design veered away from the traditional permanently attached blade configuration toward a replaceable blade and shaft configuration, wherein the blade portion was configured to include a connection member, often referred to as a “tennon”, “shank” or “hosel”, which generally comprised of an upward extension of the blade from the heel. The shafts of these contemporary designs generally were configured to include a four-sided tubular member having a connection portion comprising a socket (e.g., the hollow at the end of the tubular shaft) appropriately configured or otherwise dimensioned so that it may slidably and snugly receive the connection member of the blade. Hence, the resulting joint generally comprised a four-plane lap joint. In order to facilitate the detachable connection between the blade and the shaft and to further strengthen the integrity of the joint, a suitable bonding material or glue is typically employed. Notable in these contemporary replaceable blade and shaft configurations is that the point of attachment between the blade and the shaft is substantially elevated relative to the heel attachment employed in traditional wood type constructions.

Contemporary replaceable blades, of the type discussed above, are constructed of various materials including wood, wood laminates, wood laminate overlain with fiberglass, and what is often referred to in the industry as “composite” constructions. Such composite blade constructions employ what is generally referred to as a structural sandwich construction, which comprises a low-density rigid core faced on generally opposed front and back facing surfaces with a thin, high strength, skin or facing. The skin or facing is typically comprised of plies of woven and substantially continuous fibers, such as carbon, glass, graphite, or Kevlar™ disposed within a hardened matrix resin material. Of particular importance in this type of construction is that the core is strongly or firmly attached to the facings and is formed of a material composition that, when so attached, rigidly holds and separates the opposing faces. The improvement in strength and stiffness, relative to the weight of the structure, that is achievable by virtue of such structural sandwich constructions has found wide appeal in the industry and is widely employed by hockey stick blade manufacturers.

Contemporary composite blades are typically manufactured by employment of a resin transfer molding (RTM) process, which generally involves the following steps. First, a plurality of inner core elements composed of compressed foam, such as those made of polyurethane, are individually and together inserted into one or more woven-fiber sleeves to form an uncured blade assembly. The uncured blade assembly, including the hosel or connection member, is then inserted into a mold having the desired exterior shape of the blade. After the mold is sealed, a suitable matrix material or resin is injected into the mold to impregnate the woven-fiber sleeves. The blade assembly is then cured for a requisite time and temperature, removed from the mold, and finished. The curing of the resin serves to encapsulate the fibers within a rigid surface layer and hence facilitates the transfer of load among the fibers, thereby improving the strength of the surface layer. In addition, the curing process serves to attach the rigid foam core to the opposing faces of the blade to create—at least initially—the rigid structural sandwich construction.

Experience has shown that considerable manufacturing costs are expended on the woven-fiber sleeve materials them-

selves, and in impregnating those fiber sleeves with resin while the uncured blade assembly is in the mold. Moreover, the process of managing resin flow to impregnate the various fiber sleeves, has been found to, represent a potential source of manufacturing inconsistency.

Composite blades, nonetheless, are thought to have certain advantages over wood blades. For example, composite blades may be more readily manufactured to consistent tolerances and are generally more durable than wood blades. In addition, due to the strength that may be achieved via the employment of composite structural-sandwich construction, the blades may be made thinner and lighter than wood blades of similar strength and flexibility.

Although capable of having considerable load strength relative to weight, experience has shown that such constructions nevertheless also produce a "feel" and/or performance attributes that are unappealing to some players. Even players that choose to play with composite hockey sticks continually seek out alternative sticks having improved feel or performance. Moreover, despite the advent of contemporary composite blade constructions and two-piece replaceable blade-shaft configurations, traditional wood-constructed hockey sticks are still preferred by many players notwithstanding the drawbacks noted above.

SUMMARY OF THE INVENTION

The present invention relates to hockey sticks, their configurations and their component structures. Various aspects are set forth below.

In one aspect, a hockey stick blade comprises one or more inner core elements surrounded by one or more layers of reinforcing fibers or filaments disposed in a hardened matrix resin material. One or more of the inner core elements or components is comprised of one or more elastomer materials such as silicone rubber. The one or more elastomer inner core materials may be positioned in discrete zones in the blade to effect performance or the physical properties of the blade. For example, one or more inner cores comprising an elastomer material may be positioned in or adjacent to a designated intended impact zone, about or adjacent to the length of a portion of the circumference of the blade, and/or along or adjacent a vibration pathway to the shaft, such as in the hosel section.

In another aspect, a hockey stick blade is comprised of multiple inner core elements and an outer wall made of or otherwise comprising reinforcing fibers or filaments disposed in a hardened matrix resin. At least two of the inner core elements are made of different elastomer materials.

In yet another aspect, a hockey stick blade is comprised of multiple inner core elements and an outer wall made of reinforcing fibers or filaments disposed in a hardened matrix resin. At least one of the inner core elements is an elastomer material and at least another of the inner core elements is non-elastomer material such as a foam, a hardened resin, or a fiber or filament reinforced matrix resin.

In yet another aspect, a blade for a hockey stick includes an inner core comprising a non-elastomer material such as a hardened resin or a fiber or filament reinforced matrix resin material, surrounded on one or more sides by an elastomer material, such as silicone rubber. The elastomer material may comprise the outer surfaces of the blade, or may be overlain by one or more additional layers of non-elastomer material, such as fiber or filament reinforced matrix resin, thereby forming a blade having an elastomer material sandwiched between a non-elastomer core and a non-elastomer outer wall.

Hence, in yet another aspect, a blade for a hockey stick comprises multiple inner core elements or components made or otherwise comprised of an elastomer material, wherein the elastomer inner core elements are spaced apart in various configurations with a non-elastomer material such as a foam, a hardened resin, or a fiber or filament reinforced matrix resin residing between the elastomer core elements.

In yet another aspect, mechanical and/or physical properties are employed to further characterize elastomer materials employed in the composite blade constructs disclosed.

Yet another aspect is directed to a procedure and apparatus for measuring the coefficient of restitution of a material such as an elastomer inner core material.

In yet another aspect, the elastomer materials employed as core elements of a composite blade fall within a group of elastomer materials that maintain elastomer properties even after they are subjected to subsequent heating that occurs during the molding (e.g., such as the resin transfer molding ("RTM") process) of an uncured blade assembly comprising an inner core made of the elastomer material.

Yet another aspect is directed to preferred relative dimensions of the elastomer components to other blade components in terms of relative cross-sectional areas and blade thickness.

In yet another aspect, an adapter member is disclosed which is configured to attach the hockey stick blade to the hockey stick shaft. In yet another aspect, the adapter member includes one or more inner core elements comprised of an elastomer material.

In yet another aspect, a composite hockey stick blade made in accordance with one or more of the foregoing aspects is configured for connection with various configurations of a shaft to form a hockey stick. Hence, the composite blade may be configured to connect directly to the shaft or indirectly via an adapter member configured to join the blade with the shaft. The connection to the shaft or adapter member may be configured in a manner so that it is located at the heel, as in a traditional wood constructed hockey stick. Alternatively, the connection to the shaft may be above the heel as in contemporary two-piece hockey stick configurations. In yet another aspect, the attachment or connection between the composite blade and the shaft, whether indirect or direct, may be detachable or permanent.

In yet another aspect, a hockey stick comprises a shaft made, in part or in whole, of wood or wood laminate, and a composite blade made in accordance with one or more of the foregoing aspects.

Yet another aspect is directed to the manufacture of a hockey stick comprising a shaft and a composite blade constructed in accordance with one or more of the foregoing aspects and in accordance with one or more of the various hockey stick configurations and constructions disclosed herein, wherein the process of manufacturing the blade or adapter member includes the steps of forming an uncured blade or adapter assembly with one or more layers of resin pre-impregnated fibers or filaments and one or more other components such as a foam or elastomer inner core, placing the uncured blade assembly in a mold configured to impart the shape of the blade or adapter member; sealing the mold over the uncured blade or adapter member assembly, applying heat to the mold to cure the blade or adapter member assembly; and removing the cured blade or adapter member assembly from the mold.

In yet another aspect is directed to a hockey stick comprising a shaft and a composite blade constructed in accordance with one or more of the foregoing aspects and in accordance with one or more of the various hockey stick configurations disclosed herein.

In yet another aspect, a hockey stick is comprised of a shaft and a composite blade, wherein the hockey stick is constructed in accordance with one or more of the foregoing aspects.

Additional implementations, features, variations, and advantageous of the invention will be set forth in the description that follows, and will be further evident from the illustrations set forth in the accompanying drawings.

BRIEF DESCRIPTION OF THE DRAWINGS

The accompanying drawings illustrate presently contemplated embodiments and constructions of the invention and, together with the description, serve to explain various principles of the invention.

FIG. 1 is a diagram illustrating a first hockey stick configuration.

FIG. 2 is a rear view of a lower portion of the hockey stick illustrated in FIG. 1.

FIG. 3 is a back face view of the hockey stick blade illustrated in FIG. 1 detached from the hockey stick shaft.

FIG. 4 is a rear end view of the hockey stick blade illustrated in FIG. 3.

FIG. 5 is a diagram illustrating a second hockey stick configuration.

FIG. 6 is a rear view of a lower portion of the hockey stick illustrated in FIG. 5.

FIG. 7 is a back face view of the hockey stick blade illustrated in FIG. 5 detached from the hockey stick shaft.

FIG. 8 is a rear end view of the hockey stick blade illustrated in FIG. 7.

FIG. 9 is a bottom end view of the hockey stick shaft illustrated in FIGS. 1 and 5 detached from the blade.

FIG. 10 is a diagram illustrating a third hockey stick configuration.

FIG. 11 is a bottom end view of the hockey stick shaft illustrated in FIGS. 10 and 12 detached from the blade.

FIG. 12 is a rear view of a lower portion of the hockey stick illustrated in FIG. 10.

FIG. 13 is a back face view of the hockey stick blade illustrated in FIG. 10 detached from the hockey stick shaft.

FIG. 14A is a cross-sectional view taken along line 14-14 of FIGS. 3, 7, and 13 illustrating a first alternative construction of the hockey stick blade.

FIG. 14B is a cross-sectional view taken along line 14-14 of FIGS. 3, 7, and 13 illustrating a second alternative construction of the hockey stick blade.

FIG. 14C is a cross-sectional view taken along line 14-14 of FIGS. 3, 7 and 13 illustrating a third alternative construction of the hockey stick blade.

FIG. 14D is a cross-sectional view taken along line 14-14 of FIGS. 3, 7 and 13 illustrating a fourth alternative construction of the hockey stick blade.

FIG. 14E is a cross-sectional view taken along line 14-14 of FIGS. 3, 7 and 13 illustrating a fifth alternative construction of the hockey stick blade.

FIG. 14F is a cross-sectional view taken along line 14-14 of FIGS. 3, 7 and 13 illustrating a sixth alternative construction of the hockey stick blade.

FIG. 14G is a cross-sectional view taken along line 14-14 of FIGS. 3, 7 and 13 illustrating a seventh alternative construction of the hockey stick blade.

FIG. 14H is a cross-sectional view taken along line 14-14 of FIGS. 3, 7 and 13 illustrating an eighth alternative construction of the hockey stick blade.

FIG. 14I is a cross-sectional view taken along line 14-14 of FIGS. 3, 7 and 13 illustrating a ninth alternative construction of the hockey stick blade.

FIG. 14J is a cross-sectional view taken along line 14-14 of FIGS. 3, 7 and 13 illustrating a tenth alternative construction of the hockey stick blade.

FIG. 14K is a cross-sectional view taken along line 14-14 of FIGS. 3, 7 and 13 illustrating an eleventh alternative construction of the hockey stick blade or core component thereof.

FIG. 15A is a flow chart detailing preferred steps for manufacturing the hockey stick blade illustrated in FIGS. 14A through 14J.

FIG. 15B is a flow chart detailing preferred steps for manufacturing the hockey stick blade or core component thereof illustrated in FIG. 14K.

FIGS. 16A-C together comprise a flow chart of exemplary graphical representations detailing preferred steps for manufacturing the hockey stick blade illustrated in FIG. 14E.

FIG. 17A is a side view of an adapter member employed in a fourth hockey stick configuration illustrated in FIG. 17D; the adapter is configured to join a hockey stick blade, such as the type illustrated in FIGS. 3 and 7, to a hockey stick shaft, such as is illustrated in FIGS. 10-12.

FIG. 17B is a perspective view of the adapter member illustrated in FIG. 17A.

FIG. 17C is a cross-sectional view of the adapter member illustrated in FIGS. 17A and 17B.

FIG. 17D is a diagram illustrating a fourth hockey stick configuration employing the adapter member illustrated in FIGS. 17A-17C.

FIG. 18A is a cross-sectional view taken along line 14-14 of FIGS. 3, 7, and 13 illustrating an alternative blade construction wherein the hockey stick blade comprises a composite core overlain by a "elastomer" outer surface.

FIG. 18B is a cross-sectional view taken along line 14-14 of FIGS. 3, 7, and 13 illustrating an alternative blade construction wherein the hockey stick blade comprises a "elastomer" layer sandwiched between a composite core and composite outer surfaces.

FIGS. 19A-B are diagrams of the apparatus employed for testing and measuring performance characteristics of core materials and blade constructs as described herein.

FIG. 20 is a cross-sectional view of the hockey stick blade generally illustrated in FIGS. 10-13 taken along line 20-20 of FIG. 13 and depicts an exemplary construction of the hockey stick blade, the shaded areas represent areas of the core that are formed of an elastomer material while the un-shaded portions of the core represent areas of the core that are formed of foam.

DETAILED DESCRIPTION OF THE PREFERRED EMBODIMENTS

The preferred embodiments will now be described with reference to the drawings. To facilitate description, any reference numeral designating an element in one figure will designate the same element if used in any other figure. The following description of the preferred embodiments is only exemplary. The present invention(s) is not limited to these embodiments, but may be realized by other implementations. Furthermore, in describing preferred embodiments, specific terminology is resorted to for the sake of clarity. However, the invention is not intended to be limited to the specific terms so selected, and it is to be understood that each specific term includes all equivalents.

Hockey Stick Configurations

FIGS. 1-13 and 17 are diagrams illustrating first, second, third, and fourth hockey stick 10 configurations. Commonly shown in FIGS. 1-13 and 17 is a hockey stick 10 comprised of a shaft 20 and a blade 30. The blade 30 comprises a lower section 70, an upper section 80, a front face 90, a back face 100, a bottom edge 110, a top edge 120, a tip section 130, and a heel section 140. In the preferred embodiment, the heel section 140 generally resides between the plane defined by the top edge 120 and the plane defined by the bottom edge 110 of the blade 30. The shaft 20 comprises an upper section 40, a mid-section 50, and a lower section 60. The lower section 60 is adapted to be joined to the blade 30 or, with respect to the fourth hockey stick configuration illustrated in FIGS. 17A-D, the adapter member 1000.

The shaft 20 is preferably generally rectangular in cross-section with two wide opposed walls 150 and 160 and two narrow opposed walls 170 and 180. Narrow wall 170 includes a forward-facing surface 190 and narrow wall 180 includes a rearward-facing surface 200. The forward-facing surface 190 faces generally toward the tip section 130 of the blade 30 and is generally perpendicular to the longitudinal length (i.e., the length between the heel section 140 and the tip section 130) of the blade 30. The rearward-facing surface 200 faces generally away from the tip section 130 of the blade 30 and is also generally perpendicular to the longitudinal length of the blade 30. Wide wall 150 includes a front-facing surface 210 and wide wall 160 includes a back-facing surface 220. When the shaft 20 is attached to the blade 30, the front-facing surface 210 faces generally in the same direction as the front face 90 of the blade 30 and the back-facing surface 220 faces generally in the same direction as the back face 100 of the blade 30.

In the first and second hockey stick configurations illustrated in FIGS. 1-9, the shaft 20 includes a tapered section 330 having a reduced shaft width. The "shaft width" is defined for the purposes of this application as the dimension between the front and back facing surfaces 210 and 220. The tapered section 330 is preferably dimensioned so that when the shaft 20 is joined to the blade 30 the front and back facing surfaces 210, 220 of the shaft 20 are generally flush with the adjacent portions of the front and back faces 90 and 100 of the blade 30. The lower section 60 of the shaft 20 includes an open-ended slot 230 (best illustrated in FIG. 9) that extends from the forward-facing surface 190 of narrow wall 170 preferably, although not necessarily, through the rearward-facing surface 200 of narrow wall 180. As best illustrated in FIG. 9, the slot 230 also, but not necessarily, extends through the end surface 350 of the shaft 20. The slot 230 is dimensioned to receive, preferably slidably, a recessed or tongue portion 260 located at the heel section 140 of the blade 30.

As best illustrated in FIGS. 3-4 and 7-8, the transition between the tongue portion 260 and an adjacent portion of the blade 30 extending toward the tip section 130 forms a front-side shoulder 280 and a back-side shoulder 290, each of which generally face away from the tip section 130 of the blade 30. When the tongue portion 260 is joined to the shaft 20 via the slot 230 the forward facing surface 190 of the shaft 20 on either side of the slot 230 opposes and preferably abuts with shoulders 280 and 290. Thus, the joint formed is similar to an open slot mortise and tongue joint. The joint may be made permanent by use of adhesive such as epoxy, polyester, methacrolates (e.g., Plexus™) or any other suitable material. However, Plexus™ has been found to be suitable for this application. In addition, as in the traditional wood construction, the joint may be additionally strengthened after the blade 30 and shaft 20 are joined by an overlay of fiberglass or other suitable material over the shaft 20 and/or blade 30 or selected portions thereof.

As illustrated in FIGS. 1-4 and 9 of the first hockey stick configuration, the tongue portion 260 comprises an upper edge 300, a lower edge 310, and a rearward-facing edge 320. The blade 30 preferably includes an upper shoulder 270 that extends from the upper edge 300 of the tongue portion 260 upwardly away from the heel section 140. When the tongue portion 260 is joined within the slot 230, the forward-facing surface 190 of the shaft 200 located directly above the top of the slot 230 opposes and preferably abuts with the upper shoulder 270 of the blade 30; the rearward-facing edge 320 of the tongue 260 is preferably flush with the rearward-facing surface 200 of the shaft 20 on either side of the slot 230; the lower edge 310 of the tongue 260 is preferably flush with the end surface 350 of the shaft 20; the upper edge 300 of the tongue 260 opposes and preferably abuts with the top surface 360 of the slot 230; and the front and back side surfaces 370, 380 of the tongue 260 oppose and preferably abut with the inner sides 430, 440 of the wide opposed walls 150, 160 that define the slot 230.

As illustrated in FIGS. 5-9 of the second hockey stick configuration, the tongue portion 260 extends upwardly from the heel section 140 beyond the top edge 120 of the blade 30 and is comprised of an upper edge 300, a rearward-facing edge 320, and a forward-facing edge 340. The blade 30 includes a second set of front and back-side shoulders 240 and 250 that border the bottom of the tongue 260 and preferably face generally upwardly, away from the bottom edge 110 of the blade 30. When the tongue portion 260 is received within the slot 230, the end surface 350 of the shaft 20 on either side of the slot 230 opposes and preferably abuts with shoulders 240 and 250; the rearward-facing edge 320 of the tongue 260 is preferably flush with the rearward-facing surface 200 of the shaft 20 on either side of the slot 230; the forward-facing edge 340 of the tongue 260 is preferably flush with the forward-facing surface 190 of the shaft 20 on either side of the slot 230; the upper edge 300 of the tongue 260 opposes and preferably abuts with the top surface 360 of the slot 230; and the front and back side surfaces 370, 380 of the tongue 260 oppose and preferably abut with the inner sides 430, 440 of the wide opposed walls 150, 160 that define the slot 230.

Illustrated in FIGS. 10-13 is a third hockey stick 10 configuration. As best shown in FIG. 11 the shaft 20 is preferably comprised of a hollow tubular member preferably having a generally rectangular cross-sectional area throughout the longitudinal length of the shaft 20. The blade 30 includes an extended member or hosel portion 450 preferably comprised of two sets of opposed walls 390, 400 and 410, 420 and a mating section 460. The mating section 460 in a preferred embodiment is comprised of a rectangular cross section (also having two sets of opposed walls 390a, 400a, and 410a, 420a) that is adapted to mate with the lower section 60 of the shaft 20 in a four-plane lap joint along the inside of walls 150, 160, 170, and 180. The outside diameter of the rectangular cross-sectional area of the mating section 460 is preferably dimensioned to make a sliding and snug fit inside the hollow center of the lower section 60 of the shaft 20. Preferably, the blade 30 and shaft 20 are bonded together at the four-plane lap joint using an adhesive capable of removably cementing the blade 30 to the shaft 20. Such adhesives are commonly known and employed in the industry and include Z-Waxx™ manufactured by Easton Sports and hot melt glues. Alternatively, it is also contemplated that the joint between blade 30 and shaft 20 be made permanent by use of an appropriate adhesive.

Illustrated in FIG. 17A-D is a fourth hockey stick 10 configuration, which generally comprises the blade 30 illustrated in FIG. 3, the shaft 20 illustrated in FIGS. 10-12, and an adapter member 1000 best illustrated in FIGS. 17A-C. The

adapter member **1000** is configured at a first end section **1010** to receive the tongue **260** of the blade **30** illustrated and previously described in relation to FIGS. **3** and **7**. A second end section **1020** of the adapter member **1000** is configured to be connectable to a shaft. In the preferred embodiment, the second end section **1020** is configured to be receivable in the hollow of the shaft **20** illustrated and previously described in relation to FIGS. **10-12**. In particular, the adapter member **1000** is comprised of first and second wide opposed walls **1030**, **1040** and first and second narrow opposed walls **1050**, **1060**. The first wide opposed wall **1030** includes a front facing surface **1070** and the second wide opposed wall includes a back facing surface **1080**, such that when the adapter member **1000** is joined to the blade **30**, the front facing surface **1070** generally faces in the same direction as the front face **90** of the blade **30** and the back facing surface **1080** generally faces in the same direction as the back face **100** of the blade **30**. The first narrow opposed wall **1050** includes forward facing surface **1090** and the second narrow opposed wall **1060** includes a rearward facing surface **1100**, such that when the adapter member **1000** is joined to the blade **30**, the forward facing surface **1090** generally faces toward the tip section **130** of the blade and is generally perpendicular to the longitudinal length of the blade **30** (i.e., the length of the blade from the tip section **130** to the heel section **140**), and the rearward facing surface **1100** generally faces away from the tip section **130** of the blade **30**.

The adapter member **1000** further includes a tapered section **330'** having a reduced width between the front and back facing surfaces **1070** and **1080**. The tapered section **330'** is preferably dimensioned so that when the adapter member **1000** is joined to the blade **30**, the front and back facing surfaces **1070**, **1080** are generally flush with the adjacent portions of the front and back faces **90** and **100** of the blade **30**.

The first end section **1010** includes an open-ended slot **230'** that extends from the forward facing surface **1090** of narrow wall **1050** preferably, although not necessarily, through the rearward facing surface **1100** of narrow wall **1060**. The slot **230'** also preferably, but not necessarily, extends through the end surface **1110** of the adapter member **1000**. The slot **230'** is dimensioned to receive, preferably slidably, the recessed tongue portion **260** located at the heel section **140** of the blade **30** illustrated in FIGS. **3** and **7**.

As previously discussed in relation to the shaft illustrated in FIGS. **1-2** and **5-6**, when the slot **230'** is joined to the tongue portion **260**, the forward facing surface **1090** on either side of the slot **230'** opposes and preferably abuts the front and back side shoulders **280**, **290** of the blade **30** to form a joint similar to an open slot mortise and tongue joint. In addition, the rearward-facing edge **320** of the tongue **260** is preferably flush with the rearward facing surface **1100** of the adapter member **1000** on either side of the slot **230'**; the upper edge **300** of the tongue **260** opposes and preferably abuts with the top surface **360'** of the slot **230'**; and the front and back side surfaces **370**, **380** of the tongue **260** oppose and preferably abut with the inner sides **430'**, **440'** of the wide opposed walls **1030** and **1040** of the adapter member **1000**.

Moreover, when joined to the blade **30** configuration illustrated in FIG. **3**, the end surface **1110** of the adapter member **1000** on either side of the slot **230'** is preferably flush with the lower edge **310** of the tongue **260**. Alternatively, when joined to the blade **30** configuration illustrated in FIG. **7**, the end surface **1110** of the adapter member **1000** on either side of the slot **230'** opposes and preferably abuts shoulders **240** and **250** and the forward facing edge **340** of the tongue **260** is prefer-

ably flush with the forward facing surface **1090** of the adapter member **1000** on either side of the slot **230'**.

The second end section **1020** of the adapter member **1000**, as previously stated, is preferably configured to be receivable in the hollow of the shaft **20** previously described and illustrated in relation to FIGS. **10-12**, and includes substantially the same configuration as the mating section **460** described in relation to FIGS. **10-13**. In particular, the second end section **1020** in a preferred embodiment is comprised of a rectangular cross section having two sets of opposed walls **1030a**, **1040a** and **1050a**, **1060a** that are adapted to mate with the lower section **60** of the shaft **20** in a four-plane lap joint along the inside of walls **150**, **160**, **170**, and **180** (best illustrated in FIG. **11**). The outside diameter of the rectangular cross-sectional area of the second end section **1020** is preferably dimensioned to make a sliding fit inside the hollow center of the lower section **60** of the shaft **20**. Preferably, the adapter member **1000** and shaft **20** are bonded together at the four-plane lap joint using an adhesive capable of removably cementing the adapter member **1000** to the shaft **20** as previously discussed in relation to FIGS. **10-13**.

It is to be understood that the adapter member **1000** may be comprised of various materials, including the composite type constructions discussed below (i.e., substantially continuous fibers disposed within a resin and wrapped about one or more core materials described herein), and may also be constructed of wood or wood laminate, or wood or wood laminate overlain with outer protective material such as fiberglass. It is noted that when constructed of wood, a player may obtain the desired wood construction "feel" while retaining the performance of a composite blade construction since the adapter member **1000** joining the blade and the shaft would be comprised of wood. Thus, it is contemplated that performance attributes, such as flexibility, vibration, weight, strength and resilience, of the adapter member **1000** may be adjusted via adjustments in structural configuration (e.g., varying dimensions) and/or via the selection of construction materials including employment of the various core materials described herein.

Hockey Stick Blade Constructions

FIGS. **14A** through **14K** are cross-sectional views taken along line **14-14** of FIGS. **3**, **7**, and **13** illustrating construction configurations of the hockey stick blade **30**. It is to be understood that the configurations illustrated therein are exemplary and various aspects, such as core configurations or other internal structural configurations, illustrated or described in relation to the various constructions, may be combined or otherwise modified to facilitate particular design purposes or performance criteria. FIGS. **14A** through **14J** and **18A-B** illustrate constructions that employ one or more inner core elements **500** overlain with one or more layers **510** comprising one or more plies **520** of substantially reinforcing fibers or filaments disposed in a hardened matrix resin. The reinforcing fibers or filaments may be substantially continuous.

FIG. **14K** illustrates yet another alternative blade construction or core component construction comprising non-continuous fibers disposed in a matrix or resin base (often referred to as bulk molding compound ("BMC")). FIGS. **15A** and **16A-16C** are flow charts detailing preferred steps of manufacturing the blade constructions illustrated in FIGS. **14A-14J** and **18A-B**. FIG. **15B** is a flow chart detailing preferred steps of manufacturing the blade or core component construction illustrated in FIG. **14K**.

It is to be understood that the dimensions of the hockey sticks and the blades thereof disclosed herein may vary depending on specific design criteria. Notwithstanding, it

contemplated that the preferred embodiments are capable of being manufactured so as to comply with the design criteria set forth in the official National Hockey League Rules (e.g., Rule 19) and/or the 2002 National Collegiate Athletic Association (“NCAA”) Men’s and Women’s Ice Hockey Rules (e.g. Rule 3). Hence, it is contemplated that the hockey stick and blade constructions and configurations disclosed herein are applicable to both forward and goaltender sticks.

Commonly shown in FIGS. 14A-14J and 18A-18B are one or more inner core elements identified as 500a-500c (identified as elements 1500 in FIG. 18A-B, and 1510 in FIG. 18B), one or more layers 510 (identified as elements 1500 in FIG. 18A-B, and 1520 in FIG. 18B) comprising one or more plies identified as 520a-520d of substantially continuous fibers disposed in a hardened matrix or resin based material. Also commonly shown in FIGS. 14A-14F and 141-14J are one or more internal bridge structures commonly identified by call out reference numeral 530, which extend generally in a direction that is transverse to the front and back faces 90, 100 of the blade 30. Prior to setting forth a detailed discussion of each of these alternative constructions, a discussion of the construction materials employed is set forth.

Construction Materials

The hockey stick blades 30 illustrated in the exemplary constructions of FIGS. 14A-14K and 18A-B generally comprises one or more core elements (e.g., element 500) and one or more exterior plies (e.g., element 520) reinforcing fibers or filaments disposed in a hardened matrix resin material. Presently contemplated construction materials for each of these elements are described below.

Core Materials

Depending on the desired performance or feel that is sought, the inner core elements 500 may comprise various materials or combinations of various materials. For example, a foam core element may be employed in combination with an “elastomer” (i.e., elastomer) core and/or a core made of discontinuous or continuous fibers disposed in a resin matrix.

Foam: Foam cores such as those comprising formulations of expanding syntactic or non-syntactic foam such as polyurethane, PVC, or epoxy have been found to make suitable inner core elements for composite blade construction. Such foams typically have a relatively low density and may expand during heating to provide pressure to facilitate the molding process. Furthermore, when cured such foams are amenable to attaching strongly to the outer adjacent plies to create a rigid structural sandwich construction, which are widely employed in the industry. Applicants have found that polyurethane foam, manufactured by Burton Corporation of San Diego, Calif. is suitable for such applications.

Perhaps due to their limited elasticity, however, such foam materials have been found amenable to denting or being crushed upon singular or repetitive impact, such as that which occurs when a puck is shot. Because the inner cores of conventional hockey stick structures are essentially totally comprised of foam, compromise in the durability and/or the consistent performance of the blade structure with time and use may occur.

Elastomer or Rubber: The employment of elastomers, or rubbery materials, as significant core elements in hockey sticks, as described herein, is novel in the composite hockey stick industry. The term “elastomer” or “elastomeric”, as used herein, is defined as, or refers to, a material having properties similar to those of vulcanized natural rubber, namely, the ability to be stretched to approximately twice its original length and to retract rapidly to approximately its original length when released and includes the following materials:

- (1) vulcanized natural rubber;
- (2) synthetic thermosetting high polymers such as styrene-butadiene copolymer, polychloroprene (neoprene),

nitrile rubber, butyl rubber, polysulfide rubber (“Thiokol”), cis-1,4-polyisoprene, ethylene-propylene terpolymers (EPDM rubber), silicone rubber, and polyurethane rubber, which can be cross-linked with sulfur, peroxides, or similar agents to control elasticity characteristics; and

- (3) Thermoplastic elastomers including polyolefins or TPO rubbers, polyester elastomers such as those marketed under the trade name “Hytrel” by E.I. Du Pont; ionomer resins such as those marketed under the trade-name “Surlyn” by E.I. Du Pont, and cyclic monomer elastomers such as di-cyclo pentadiene (DCPD).

Notably, composite structures employing elastomer cores, as a general principle, do not follow the classic formulas for calculating sandwich loads and deflections. This is so because these materials are elastic and therefore are less amenable to forming a rigid internal structure with the exterior skin or plies of the sandwich. Consequently, it is no surprise that composite hockey stick structures (e.g., composite blades) comprising elastomer cores are absent from the industry. Notwithstanding, applicants have found that the employment of such elastomer cores individually or in combination with other core materials, such as foam, are capable of providing desirable feel and/or performance characteristics.

For example, the sound that is generated when a hockey puck is struck by a hockey stick can be modified with the employment of such elastomer cores to produce a uniquely pleasing sound to the player as opposed to the “hollow-pingy” type sound that is typically created with traditional composite hockey sticks. Further, the resilient elasticity of elastomers make them suited to the unique dynamics endured by hockey stick blades and components. Unlike conventional foam core materials, elastomer cores can be chosen such that their coefficients of restitution (CORs) are comparable to wood, yet by virtue of their resilient properties are capable of withstanding repetitive impact and thereby provide consistent performance and suitable durability.

Moreover, employment of elastomer core materials have been found to impact or dampen the significance of the vibration typically produced from a traditional foam core composite blade and thereby provide a manner of controlling or tuning the vibration to a desired or more desirable feel.

In addition, because elastomers are available with significant ranges in such mechanical properties as elasticity, resilience, elongation percentage, density, hardness, etc. they are amenable to being employed to achieve particular product performance criteria. For example, an elastomer may have properties that are suitable for providing both a desired coefficient of restitution while at the same time suitable for achieving the desired vibration dampening or sound. Alternatively, a combination of elastomers may be employed to achieve the desired performance attributes, perhaps one more suited for dampening while the other being better suited for attaining the desired coefficient of restitution. Thus, it has been found that the use of elastomer cores can facilitate unique control or modification over performance criteria.

Moreover, it is to be understood that the elastomer may be employed in a limited capacity and need not constitute the totality, or even a majority, of the core. This is especially significant in that elastomer materials typically have densities significantly greater than conventional foam core materials, and hence may significantly add to the overall weight of the blade and the hockey stick. Thus, for example, it may be preferable that elastomer materials be placed in discrete strategic locations—such as in and/or around a defined impact zone of the blade, along the outer circumference of the blade, or along vibration transmission pathways perhaps in the

hosel, heel or along the edge of the blade. They may be placed in vertical and/or horizontal lengths within the core at spaced intervals. For example, reference is made to FIG. 20, shown therein is a cross-sectional diagram of the hockey stick blade taken generally longitudinally along the plane of the hockey stick blade 30 as identified by line 20-20 in FIG. 13. The elastomer core components are identified by shading and the foam core components are identified as the portions of the core that are not shaded. Moreover, it is to be understood that dimensions (e.g., thickness, height, width) of one or more of the core materials, whether an elastomer or otherwise, may be varied relative to the external blade 30 dimensions, or relative to other internal blade components or structures. Thus, for example it is contemplated that the thickness of the core may be thinner at the tip section 130 and along the upper edge 120 than at regions more proximate to the heel region 140 and the bottom or lower edge 110. Thus for example in FIG. 20 it is contemplated that the thickness of the more distally positioned elastomer core element is generally thinner than the more proximately positioned elastomer core element. The foam core element interposed between the distally and proximately positioned elastomer core element would have a thickness dimension generally in between the those of the adjacent elastomer core elements.

Furthermore, it is to be understood that elastomer materials may be combined in discrete layers and/or sections with more traditional core structures (e.g., foam, wood, or wood laminate) and/or other materials such as plastics, or other fiber composite structures, such as a material comprised of continuous or discontinuous fibers or filaments disposed in a matrix resin. In addition, it is also contemplated that combinations of core materials may be blended or otherwise mixed. Preferred Characterizations and Implementations of Elastomeric Materials

Preferred characterizations of elastomer materials and preferred implementations of elastomer cores and structures are set forth in the following paragraphs. It is to be understood that each of the following characterizations and/or implementations may be employed independently from or in combination with one or more of the other preferred characterizations and/or implementations to further define the preferred hockey stick and blade configurations, embodiments, and constructions.

First Preferred Characterization: A first preferred characterization of the materials that fall within the definition of "elastomer" as used and described herein include materials that have a ratio of the specific gravity ("SG") to the coefficient of restitution ("COR") less than or equal to five (5.0), as described by the formula set forth below:

$$SG \div COR \leq 5.0 \quad (1)$$

Where:

SG: is the ratio of the weight or mass of a given volume of any substance to that of an equal volume of water at four degrees Celsius; and

COR: also known as the "restitution coefficient", can vary from 0 to 1 and is generally the relative velocity of two bodies of mass after impact to that before impact as further described by the "Coefficient of Restitution Test" procedure and apparatus set forth below and illustrated in FIGS. 19A-B.

"Coefficient of Restitution Test": The foregoing "Coefficient of Restitution Test" procedure is novel in the hockey stick industry. The test procedure is similar in some aspects to ASTM Designation F 1887-98 entitled Standard Test Method for Measuring the Coefficient of Restitution (COR) of Baseballs and Softballs, which was published in February 1999.

FIGS. 19A-B are illustrations of the testing apparatus. The procedure is intended to set forth the method of measuring the coefficient of restitution of core materials used in composite constructs, particularly hockey stick blades and component parts, as described herein. Further, the procedure is intended to establish a single, repeatable, and uniform test method for testing such core materials.

The test method is based on the velocity measurement of a steel ball bearing before and after impact of the test specimen. As defined herein, the "coefficient of restitution" (COR) is a numerical value determined by the exit speed of the steel ball bearing after contact divided by the incoming speed of the steel ball bearing before contact with the test specimen. The dimensions of the test specimen are $7 \pm 0.125 \times 2 \pm 0.125 \times 0.25 \pm 0.0625$ inches. Notwithstanding the foregoing dimensional tolerances of the test specimens, it is to be understood that the specimens are to be prepared with dimensions that are as accurate as reasonably possible when employing this test procedure.

Once the test specimen is prepared, it is firmly secured to a massive, rigid, flat wall, which is comprised of a 0.75 inch-thick steel plate mounted on top of a 2.50 inch-thick steel table. The sample specimen is secured to the steel plate via clamps positioned at the ends of the specimen, approximately equal distance from the specimens geometric center. The clamps should be sufficiently tightened to the steel plate over the specimen to be tested so as to inhibit the specimen from moving when impacted by the steel ball bearing. Clamp placement should be approximately 5.0 inches apart or 2.5 inches from the specimens center, which resides in the intended impact zone.

The steel ball bearing is made of 440 C grade steel and has a Rockwell hardness between C58-C65, a weight of 66.0 grams ± 0.25 grams, a sphericity of 0.0001 inches, and a diameter of 0.75 inches ± 0.0005 inches. See ASTM D 756 entitled Practice for Determination of Weight and Shape changes of Plastic Under Accelerated Service Conditions. Such spherical steel ball bearings meeting the foregoing criteria may be procured from McMaster Carr, USA or any other suitable or available source or vendor.

Electronic speed monitors measure the steel ball bearings speed before and after impact with the test specimen. Each speed monitor is comprised of generally two components: (1) a vertical light screen and (2) a photoelectric sensor. The vertical light screens are mounted 2.0 ± 0.125 inches apart, with the lower light screen being mounted 5 ± 0.125 inches above the top surface of the 0.75 inch thick steel plate. Two photoelectric sensors, one located at each screen, trigger a timing device on the steel ball bearing passage thereby measuring the time for the ball to traverse the distance between the two vertical planes before and after impact with the test specimen. The resolution of the measuring apparatus shall be ± 0.03 m/s.

The test room shall be environmentally controlled having a temperature of 72° F. ± 6 ° F., a relative humidity of 50% ± 5 %. Prior to testing, the specimens are to be conditioned by placing them for at least 12 hours in an environmentally controlled space having the same temperature and relative humidity as the test room.

The steel ball bearing shall be dropped from a height of 30.5 inches ± 0.2 inches. The ball shall be dropped 25 times on the specimen via the employment of a suitable release device, such as a solenoid. A minimum of a 45-second rest period is required between each drop. The average of the 25

COR values for each specimen is used to determine the COR of the specimen, in accordance with the following formulae:

$$COR = V_b/V_a = 1/25[(V_{b1}/V_{a1}) + (V_{b2}/V_{a2}) + (V_{b3}/V_{a3}) + \dots + (V_{b23}/V_{a23}) + (V_{b24}/V_{a24}) + (V_{b25}/V_{a25})] \quad (2)$$

Where:

V_a = incoming speed adjusted or compensated for the effects of gravity, and

V_b = exit speed adjusted or compensated for the effects of gravity.

Data acquisition hardware such as that marketed under the trade name "Lab View" and data acquisition circuit boards may be obtained from National Instruments Corporation located in Austin, Tex.; and suitable wiring from sensors to acquisition ports may be obtained from Keyence Corporation of America located in Torrance, Calif.

Second Preferred Characterization: A second preferred characterization of the materials that fall within the definition of "elastomeric" as used and described herein include materials that have an ultimate elongation equal to or greater than 100% in accordance with the following formula:

$$\text{Ultimate Elongation Percentage} = \{[(\text{final length at rupture}) - (\text{original length})] / \text{original length}\} \times 100 \quad (3)$$

Where: Ultimate Elongation: also referred to as the breaking elongation, is the elongation at which specimen rupture occurs in the application of continued tensile stress as measured in accordance with ASTM Designation D 412 Standard Test Methods for Vulcanized Rubber and Thermoplastic Elastomers—Tension (August 1998).

Third Preferred Characterization: A third preferred characterization of the materials that fall within the definition of "elastomer" as used and described herein include materials that are capable of undergoing a subsequent heating and pressure commensurate with curing and molding (e.g., such as the RTM process previously discussed or the process described in relation to FIGS. 15A and 16), yet still fall within the definition of an elastomer as defined herein. For example in a typical molding process such as that disclosed in relation to the process described in FIG. 15A, the blade assembly may be subject to a cure temperature between 200 and 350 degrees Fahrenheit for a period ranging from 10 to 20 minutes and commensurate pressure resulting therefrom. Hence, the third preferred characterization relates to employment of a material that can undergo such processing and still fall within the definition of an elastomer as described herein.

First Preferred Implementation: A first preferred implementation of an elastomer core material in a composite structure, such as a hockey stick blade, as used and described herein is defined by the ratio of the cross-sectional area comprising an elastomer core divided by the total cross sectional area, in accordance with the following formula:

$$A_E/A_T \geq 0.25 \quad (4)$$

Where:

A_E : is the cumulative area at any given cross-section of the blade that is occupied by an elastomer; and

A_T : is the total area at the same cross-section of the blade.

The foregoing preferred implementation is applicable to any cross-section of the blade 30 regardless of where along the blade that cross-section is taken. It is to be understood, however, that this preferred implementation employs a cross-sectional area that is generally perpendicular to the front and back faces 90, 100 of the blade 30 such as those illustrated in FIGS. 14A-14K and 18A-B.

Second Preferred Implementation: A second preferred implementation of an elastomer core in a composite structure, such as a hockey stick blade, as used and described herein is defined by the ratio of the thickness of the elastomer divided by the total thickness of the blade, in accordance with the following formula:

$$T_E/T_T \geq 0.25 \quad (5)$$

Where:

T_E : is the cumulative thickness of all elastomer core materials at any given cross-sectional plane of the blade, as described above in relation to the first preferred implementation, and as measured along a line on that cross-sectional plane that is generally normal to one or both (i.e., at least one) of the faces 90, 100 of the blade 30 at the point where the line intersects the face; and

T_T : is the total thickness of the blade as measured along the same line of measurement employed in the measurement of T_E .

Alternative First and Second Preferred Implementations: Alternative first and second preferred implementations of an elastomer core material in a composite structure, such as a hockey stick blade, as used and described herein is defined as set forth in the first and second preferred implementations described above in relation to equations (4) and (5), except that:

A_T : is defined as A_T' , and is no longer the total area at the cross-section of the blade but rather is the total area at the cross-section occupied by fibers or filaments disposed in a hardened matrix or resin material; and

T_T : is defined as T_T' , and is no longer the total thickness of the blade as measured along the same line of measurement employed in the measurement of T_E , but rather is the total thickness of the layer(s) comprising fibers or filaments disposed in a hardened matrix or resin material as measured along the same line of measurement employed in the measurement of T_E .

Elastomer Core Testing and Related Data

Four elastomer core materials made of silicone rubber, which are identified in the following tables as M-1 to M-4, were prepared and the samples were subjected to COR comparison testing. The cores were compared to materials traditionally employed in conventional hockey stick blades, in particular wood, resin matrix, foam, and plastic. Table 1 is a compilation of that data.

TABLE 1

Material/ Description	S.G.	Hardness [Shore A points]	Tensile Strength [psi]	Elongation [%]	Tear Strength		
					Die B [lbs/inch]	COR	SG + COR
M-1	1.28	56	900	120	40	0.541	2.37
M-2:	1.15	5	436	731	110	0.590	1.95
M-3	1.13	20	914	600	132	0.614	1.84
M-4	1.11	40	525	225	100	0.635	1.75

TABLE 1-continued

Material/ Description	S.G.	Hardness [Shore A points]	Tensile Strength [psi]	Elongation [%]	Tear Strength Die B [lbs/inch]	COR	SG + COR
Wood (Ash)	0.69					0.564	1.22
Resin Matrix	8.20					0.832	9.86
Foam	0.14					— ¹	
Plastic	1.01					0.667	1.51

¹The steel ball bearing did not bounce-off the foam sample when it was tested for COR and therefore the COR measurement is negligible.

The values of specific gravity, hardness, tensile strength, elongation percentage and tear strength for the silicone rubber samples M-1 to M-4, were provided by the manufacturer and are understood to comply with ASTM measurement standards. Table 2 is a compilation of the trade names and manufacturers of the materials set forth above in Table 1.

TABLE 2

Material/ Description	Manufacturer	Trade Name
M-1	Dow Corning	Silastic J
M-2:	Dow Corning	HS IV RTV High Strength
M-3	Dow Corning	Silastic S-2 RTV
M-4	Circle K	GI-1040 RTV
Resin Matrix:	Dow Chemical	D.E.R. 332 Epoxy Resin
Foam	Burton Corporation, San Diego, CA	BUC-500 Foam
Plastic	Generic	Acrylonitrile Butadine Styrene Resin ("ABS")

As noted in Table 1, the specific gravity for each of the silicone rubber core materials M-1 to M-4 was significantly greater than the foam yet significantly less than the resin. In addition, the measured COR for each of the silicone rubber core materials were comparable to the COR measured for the wood specimen. Furthermore, the measured COR of the silicone rubber samples exhibited a generally linear increase with decreasing S. G. values.

Thin and thick walled composite hockey stick blade constructs were manufactured with cores made of each of the four silicone rubber samples as well as the foam sample. The thin and thick walled composite blades were manufactured using the same blade mold and generally in accordance with the procedure described in relation to FIG. 15A. It is to be understood the phrase thin and thick walled refers to the walls of the blade between which the core material is interposed. Hence a thick walled blade would be formed with a thicker layer of fibers disposed within a hardened resin matrix material than a thin walled blade.

The constructs were then subjected to comparative COR testing. The same test apparatus was employed as discussed in relation to the COR Test Procedure set forth above, except that the steel ball bearing used in the test had a weight of 222.3+/-0.25 grams, a sphericity of 0.0001 inches, and a diameter of 1.00+/-0.0005 inches. In addition, since the specimens were comprised of composite blade constructs, the specimen dimensions set forth in the COR Test Procedure set forth above also were different. Table 3 sets forth the COR data of these tests.

TABLE 3

Material/ Description	COR of Thin Blade Construct (tested)	COR of Thick Blade Construct (tested)
M-1	0.892	0.899
M-2	0.925	0.938
M-3	0.929	0.875
M-4	0.945	0.961
Foam	0.944	0.988

Notably, in all but one of the test specimens (M-3) an increase in the COR was measured with an increase in wall thickness of the blade. Further, the greatest percent increase in the COR from the thick walled blade over the thin walled blade was measured in the foam core blade construct.

Comparative spring rate testing was conducted on the silicone rubber samples (M-1 to M-4) and the foam core for both a thin and thick walled blade constructs. The test consisted of placing a load on the blade construct at a uniform load rate of 0.005 inches/second and obtaining load versus deflection curves. The maximum loads for the thin and thick walled composite blade constructs was 80 lbs and 150 lbs, respectively. The loads were placed on the same position on each of the blade constructs. The following data set forth in Table 4 below was obtained:

TABLE 4

Material/ Description	Spring Rate of Thin Blade Construct (tested [lbs/in])	Spring Rate of Thick Blade Construct (tested [lbs/in])
M-1	6228.8	6877.0
M-2:	3674.5	5601.0
M-3	4580.0	6768.5
M-4	4850.9	6077.7
Foam	6131.9	6139.3

As can be seen from the data, the spring rate showed a significant increase between the thin and thick blade constructs for the silicone samples. The spring rate in the foam core construct, on the other hand, did not markedly increase with increased wall thickness.

Comparative vibration testing was also conducted on the thin and thick blade composite constructs. Measurements of maximum vibration amplitudes (measured in gravity increments) and a qualitative comparison of decay times were recorded. The test consisted of securing the composite blade construct at the hosel against an L-bracket and deflecting the blade at its toe a distance of 0.5 inches. Upon release of the deflected blade, vibration of the blade was measured via an

accelerometer placed at 1.25 inches from the toe of the blade. The following data set forth below in Table 5 was recorded:

TABLE 5

Material/ Description	Max Accel. of Thin Blade Construct (tested [g's])	Decay Time of Thin Blade Construct (tested [s])	Max Accel. of Thick Blade Construct (tested [g's])	Decay Time of Thick Blade Construct (tested [s])
M-1	57.7	0.67	88.0	0.54
M-2	81.6	0.68	83.9	0.82
M-3	77.2	0.87	93.7	0.72
M-4	82.2	0.78	94.6	0.70
Foam	139.0	1.09	95.3	0.73

A similar vibration test was conducted on an all wood hockey stick blade, the data is set forth in Table 6 below:

TABLE 6

Material/ Description	Max Accel. (tested [g's])	Decay Time (tested [s])
Wood	18.7	1.09

Notably, the measurement of maximum acceleration is a measure of the initial vibration of the blade that occurs subsequent release of the deflected blade and is a reflection of the blade's capability to transmit vibration. The measurement of decay time is a measure of the duration or time required for the vibration of the blade to dissipate or be absorbed and therefore is a measure of the blades capability of dampening vibration.

With respect to the maximum acceleration data measured from the testing of the thin walled blade constructs, it is noted that the silicone rubber core constructs measured significantly less than the foam core construct. In addition, with respect to the decay times of the thin walled blade constructs, it is noted that the silicone rubber core constructs measured significantly less than the decay time of the foam core construct.

When one compares the maximum acceleration between the thin walled blade constructs and the thick walled blade constructs, it is noted that the silicone rubber core constructs tended to increase with blade wall thickness while the maximum acceleration of the foam core construct reflected a significant decrease. When one compares the decay times between the thin walled blade constructs and the thick walled blade constructs, it is noted that the silicone rubber constructs generally measured a slight decrease with increasing blade wall thickness where as the foam construct measured a significantly larger decrease in decay time with increasing blade wall thickness.

In addition, a qualitative comparison to the all wood blade construct indicates that although the maximum acceleration or vibration of the all wood construct measured less than any of the silicone rubber core constructs, the decay time was significantly greater in the all wood constructs than the silicone-rubber constructs.

Thus, the data suggest that an elastomer core is capable of effecting in a unique manner not only the spring rate and the COR as previously described and discussed, but it is also capable of providing a reduced decay time when compared to the foam and wood blade constructs as well as a decreased maximum acceleration closer to a wood blade construct than a traditional foam core construct.

“Bulk Molding Compound” Cores: Bulk molding compounds are generally defined as non-continuous fibers disposed in a matrix or resin base material, which when cured become rigid solids. Bulk molding compound can be employed as an inner core element or can form the totality of the blade 30 structure. This type of blade 30 or core 500 construction is best illustrated in FIG. 14K. When employed as either a blade 30 or core component 500 thereof, it is preferable that the bulk molding compound be cured in an initial molding operation, preferred steps for which are described in FIG. 15B. Initially, bulk molding compound is loaded into a mold configured for molding the desired exterior shape of the blade 30 or core element 500 (step 700 of FIG. 15B). With respect to the loading of the mold, it has been found preferable to somewhat overload the mold with the compound so that when the mold is sealed or closed, the excess compound material exudes from the mold. Such a loading procedure has been found to improve the exterior surface of the cured molded structure. Once the mold is loaded, heat is applied to the mold for curing (step 710), and the cured blade 30 or core element 500 is removed from the mold (step 720). Additionally, if required, the mold is finished to the desired appearance as a blade 30, or prepared for incorporation in the blade 30 as a core element 500.

25 Ply Materials/Fibers & Matrix/Resin

As used herein, the term “ply” shall mean “a group of fibers which all run in a single direction, largely parallel to one another, and which may or may not be interwoven with or stitched to one or more other groups of fibers each of which may or may not be disposed in a different direction.” Unless otherwise defined, a “layer” shall mean one or more plies that are laid down together.

The fibers employed in plies 520 may be comprised of carbon fiber, aramid (such as Kevlar™ manufactured by Dupont Corporation), glass, polyethylene (such as Spectra™ manufactured by Allied Signal Corporation), ceramic (such as Nextel™ manufactured by 3 m Corporation), boron, quartz, polyester or any other fiber that may provide the desired strength. Preferably, at least part of one of the fibers is selected from the group consisting of carbon fiber, aramid, glass, polyethylene, ceramic, boron, quartz, and polyester; even more preferably from the group consisting of carbon fiber, aramid, glass, polyethylene, ceramic, boron, and quartz; yet even more preferably from the group consisting of carbon fiber, aramid, glass, polyethylene, ceramic, and boron; yet even more preferably from the group consisting of carbon fiber, aramid, glass, polyethylene, and ceramic; yet even more preferably from the group consisting of carbon fiber, aramid, glass, and polyethylene; yet even more preferably from the group consisting of carbon fiber, aramid, and glass; yet even more preferably from the group consisting of carbon fiber and aramid; and most preferably comprises carbon fiber.

It has been found preferable that each uni-directional fiber ply be oriented so that the fibers run in a different and preferably a perpendicular direction from the underlying or overlying uni-directional ply. In a preferred construction lay-up, each ply is oriented so that the fibers run at preferably between +/-30 to 80 degrees relative to the longitudinal length of the blade 30 (i.e., the length from the heel section 140 to the tip section 130), and more preferably between +/-40 to 60 degrees, yet more preferably between +/-40 to 50 degrees, even more preferably between 42.5 and 47.5 degrees, and most preferably at substantially +/-45 degrees. Other ply orientations may also be independently or in conjunction with the foregoing orientations. For example, it has been found preferable that an intermediate zero degree oriented ply be included between one or more of the plies 520 to

provide additional longitudinal stiffness to the blade 30. In addition, for example, a woven outer ply (made of e.g., Kevlar™, glass, or graphite) might be included to provide additional strength or to provide desired aesthetics. Furthermore, one or more plies may be employed which may or may not be uni-directional or woven. Moreover, it is to be understood that additional plies may be placed at discrete locations on the blade 30 to provide additional strength or rigidity thereto. For example, additional plies may be placed at or around the general area where the puck typically contacts the blade 30 during high impact shots (such as a slap shot), in an area where the blade typically meets the ice surface such as at or about the bottom edge 110, or in the general area on the blade 30 that is adapted to connect to the hockey stick shaft 20 or an adapter 1000 such as that illustrated in FIGS. 17A-D, for example the heel region 140, tongue 260 or hosel 450 portion of the blade 30,

The matrix or resin-based material is selected from a group including: (1) thermoplastics such as polyether-ketone, polyphenylene sulfide, polyethylene, polypropylene, urethanes (thermoplastic), and Nylon-6, and (2) thermosets such as urethanes (thermosetting), epoxy, vinylester, polycyanate, and polyester.

In order to avoid manufacturing expenses related to transferring the resin into the mold, the matrix material may be pre-impregnated into the fibers or filaments, plies 520 or layers 510 prior to the uncured blade assembly being inserted into the mold and the mold being sealed. In addition, in order to avoid costs associated with employment of woven sleeve materials, it may be preferable that the layers 510 be comprised of one or more plies 520 of non-woven uni-directional fibers. Applicants have found that a suitable material includes uni-directional carbon fiber tape pre-impregnated with epoxy, manufactured by Hexcel Corporation of Salt Lake City, Utah, and also S & P Systems of San Diego, Calif. Another suitable material includes uni-directional glass fiber tape pre-impregnated with epoxy, also manufactured by Hexcel Corporation. Yet another suitable material includes uni-directional Kevlar™ fiber tape pre-impregnated with epoxy, also manufactured by Hexcel Corporation.

Employment of such pre-impregnated materials has been found by applicants to be particularly suitable for serving as an adhesive to secure the layers of fibers or one or more plies to one another, as well as to the core or other structural component. Hence, the employment of these materials may serve to facilitate the fixing of the relative position of the pre-cured blade assembly components. Moreover, such pre-impregnated materials have been found advantageous when employed internally in so much as the resin need not flow or otherwise be transferred into the internal portions of the blade 30 during the curing molding and curing process of the blade assembly. For example, internal structures, such as the bridge structures 530 of the various blade 30 constructions illustrated in FIGS. 14B-14F, 141 and 14J, as well as the internal ply layers 510 best illustrated in FIGS. 14G and 14J and 18B, are particularly suited to being formed from such pre-impregnated materials. By pre-positioning the resin in the desired locations, control over the disposition of the resin in the internal structure component(s) can be exercised, such as at the bridge structure 530 as well as the internal layers 510 or plies 520.

Exemplary Alternative Blade Construction Configurations

Exemplary alternative blade 30 constructions illustrated in FIGS. 14A through 14K and 18A-B are described in turn below. It is to be understood that the various cores may be comprised of various materials (e.g., foam, wood, wood lami-

nate, elastomer material, bulk molding compound, etc.) to achieve desired performance characteristics and/or unique feel.

With reference to FIG. 15A, the blade 30 constructions illustrated in FIGS. 14A through 14F and 18B are generally constructed in accordance with the following preferred steps. First, one or more plies 520, layers, or groups of fibers or filaments are wrapped over one or more inner core elements 500a-500c (e.g., wood, wood laminate, elastomer material, foam, bulk molding compound, etc.), which individually or in combination generally form the shape of the blade 30 illustrated in FIGS. 3, 7, or 13 (step 600) to create an uncured blade assembly.

Once the uncured blade assembly is prepared, it is inserted into a mold that is configured to impart the desired exterior shape of the blade 30 or component thereof (step 610 of FIG. 15A). The mold is then sealed, after which heat is applied to the mold to cure the blade assembly (step 620 of FIG. 15A). The blade 30 is then removed from the mold and finished to the desired appearance (step 630 of FIG. 15A). The finishing process may include aesthetic aspects such as paint or polishing and also may include structural modifications such as deburring. Once the blade 30 is finished, the blade 30 is then ready for attachment to the shaft 20.

It is to be understood that in order to avoid subsequently injecting resin or matrix material into the mold after the blade assembly is placed therein (such as in a conventional resin transfer molding (RTM) processes described above) a preferred construction process employs fibers, plies or layers of fiber plies that are pre-impregnated with a resin or matrix, as previously noted. An RTM method or a combination of an RTM and pre-preg method process may be employed, however, if desired for a given application.

As shown in the preferred embodiment illustrated in FIG. 14A, a three-piece core 500a, 500b, and 500c is employed. Overlaying the centrally positioned core element 500b are two plies 520a and 520b. In application, plies 520a and 520b may be wrapped around core element 500b as a single layer. Once plies 520a and 520b are wrapped around the core element 500b, plies 520c, 520d, and 520e are wrapped over plies 520a and 520b and around core elements 500a and 500c. The uncured blade assembly is then inserted into a suitable mold configured to impart the desired exterior shape of the blade 30, as previously discussed in relation to step 610 of FIG. 15A. Once cured, plies 520a and 520b create internal bridge structures 530 that extend from one side of the blade 30 to the other (i.e., from the inner facing surface of ply 520c on one side of the blade to the inner facing surface of ply 520c on the other side of the blade 30) and thereby may provide additional internal strength or impact resistance to the blade 30.

The internal bridge structure 530 previously referenced in relation to FIG. 14A, and also illustrated and discussed in relation to FIGS. 14B through 14F, may extend only along a desired discrete portion of the longitudinal length (i.e., the length from the heel to the tip section) of the blade 30. However, an advantage that may be realized by employing an internal bridge structure(s) that extend into the recessed or tongue portion 260 of the heel 140 of the blade 30 is the capability of imparting additional strength at the joint between the blade 30 and the shaft 20. Moreover, by extending the internal bridge structure(s) into the tongue 260 of the blade 30, a potentially more desirable or controlled blade 30 flex may be capable at the joint.

FIGS. 14B and 14C illustrate second and third preferred constructions of the blade 30, each of which also comprises a plurality of inner core elements 500a, 500b and 500a, 500b, 500c, respectively. Three plies 520a, 520b, and 520c overlay

the inner core elements. The positions of the interface, or close proximity of the plies **520** on opposite sides of the blade **30** (i.e., positions where opposed sides of ply **520a**, **520b**, and **520c** are positioned in close proximity towards one another so that opposed sides of ply **520a** are preferably touching one another), cause the formation of internal bridge structure(s) **530** interposed between the core elements. The function and preferred position of the internal bridge structure(s) **530** are the same as those described in relation to FIG. **14A**.

In application, the bridge structure(s) **530** illustrated in FIGS. **14B** and **14C** can be implemented by the following process. First, a single core **500**, having generally the shape of the blade **30**, is provided and wrapped with plies **520a**, **520b**, and **520c** to create an uncured blade assembly (step **600** of FIG. **15A**). The blade assembly is then inserted into a mold having convex surfaces configured to impart the desired bridge structure **530** into the blade **30** (step **610** of FIG. **15A**). The convex surfaces force the core structure out of the defined bridge structure region and create a bias that urges the internal sides of the plies toward one another at that defined region. The convex surface(s) may be integral with the mold or may be created by insertion of a suitable material, such as expanding silicone, into the mold at the desired location(s).

Thus, in a preferred application, a single core element **500** is partitioned during the molding process to create the discrete core elements. Such a process is capable of reducing the manufacturing costs and expenditures related to forming a multi-piece core structure, as well as the time associated with wrapping the plies about a multi-piece core structure, as described above in relation to the core element **500b** of FIG. **14A**. In order to create a more desirable blade surface configuration after the blade assembly is cured, the cavities **540** formed by this process may be filled by a suitable filler material **570** such as fiberglass, urethane, epoxy, ABS, styrene, polystyrene, resin or any other suitable material to effectuate the desired outer surface and performance results. Filling the cavities **540** with urethane, for example, may assist in gripping the puck.

FIG. **14D** illustrates a fourth preferred construction of the blade **30**, which also comprises a plurality of inner core elements **500a** and **500b** overlain with three plies **520a**, **520b**, and **520c**. Extending between the inner core elements **500a** and **500b** is a bead **590** of preferably pre-impregnated fiber material, such as carbon or glass fiber. A preferred construction process includes the following steps. First, a core element **500**, generally having the shape of the blade **30**, is provided, and a cavity or slot is imparted (e.g., by mechanical means) within the core element **500** along a portion of its longitudinal length (i.e., generally from the heel section to the toe section) so as to define core elements **500a** and **500b**. Alternatively, the core element **500** may be molded to include the cavity or slot, thus avoiding the costs associated with mechanical formation of the cavity or slit into the core element **500**. As previously noted in relation to the internal bridge structure **530** of FIG. **14A**, the bead **590** preferably extends longitudinally into the tongue **260** of the blade **30** so that it may provide additional strength at the joint between the shaft **20** and the blade **30**. The cavity or slot is filled with a bead of preferably pre-impregnated fibers. The fiber bead may be comprised of a single layer of substantially continuous pre-impregnated fibers that are rolled or layered to achieve the desired dimensions to fill the cavity/slot. Alternatively, the bead may be comprised of a non-continuous fiber and resin mixture referred to in the industry as "bulk molding compound" or an elastomer material. The fibers in the bulk molding compound may be selected from the group of fibers previously identified with respect to the substantially continuous fibers employed in plies **520**.

Once the bead of fiber material is laid in the cavity between core elements **500a** and **500b**, plies **520a**, **520b**, and **520c** are wrapped around the foam core elements to form an uncured blade assembly (step **600** of FIG. **15A**). The uncured blade assembly is then inserted into a mold having the desired exterior shape of the blade **30** (step **620** of FIG. **15A**), and heat is applied to the mold for curing (step **630** of FIG. **15B**). The bead **590** of fiber material forms an internal bridge structure **530** between opposing sides of the blade **30**, and is disposed between the core elements **500a** and **500b**, the function of which is as previously noted in relation to the bridge structure **530** discussed in relation to FIG. **14A**.

FIG. **14E** illustrates a fifth preferred construction of the hockey stick blade **30**. In addition to the preferred steps set forth in FIG. **15A**, a preferred process for manufacturing this preferred construction is set forth in more detail in FIGS. **16A-16C**. With reference to FIG. **14E**, the preferred steps described and illustrated in FIGS. **16A-16C** (steps **900** through **960**) will now be discussed. First, as illustrated in FIG. **16A**, a core **500** is provided and is preferably configured to include a recessed tongue section **260a** at the heel section **140** of the blade **30** (step **900**). The core **500** may preferably be molded to have a partition **800** that generally extends the longitudinal length of the blade **30** from the tip section **130** to the heel section **140**. Alternatively, the partition **800** may be mechanically imparted to a unitary core structure **500**.

The core **500** is then separated along partition line **800** into core elements **500a** and **500b**, and inner layers **810a** and **810b** are provided (step **910**). As illustrated in step **910**, the inner layers **810a** and **810b** are preferably dimensioned such that, when they are wrapped around the respective core elements **500a** and **500b**, they extend to the respective upper edges **820a** and **820b** of the foam core **500a** and **500b** (step **920** of FIG. **16B**). With reference to FIG. **14E**, each layer **810a** and **810b** is preferably comprised of two plies **520a** and **520b**, but any other suitable number of plies may be employed.

Layers **810a** and **810b** at the partition **800** are then mated together so that layers **810a** and **810b** are interposed within the partition **800** (step **930**). Preferably, this may be achieved by touching the mating surfaces of layers **810a** and **810b** to a hot plate or hot pad to heat the resin pre-impregnated in the plies **520a** of the outer layers **810a** and **810b** and thereby facilitate adhesion of the layers **810a** and **810b** to one another.

A cap layer **830** may be wrapped around the circumference of the blade assembly (step **940**). When employed, the cap layer **830** is preferably dimensioned so that its length is sufficient to completely reach the outer edges of the foam core elements **500a** and **500b** when mated together at the partition **800**, as described in relation to step **930**. In addition, as best illustrated in step **940** and FIG. **14F**, the width of the cap layer **830** is dimensioned so that when the cap layer **830** is wrapped around the circumference of the core elements **500a** and **500b**, the cap layer **830** overlaps the outer surfaces of layers **810a** and **810b**. As best illustrated in FIG. **14E**, the cap layer **830** is preferably comprised of two plies **560a** and **560b**, but any other suitable number of plies may be employed.

As illustrated at step **950** of FIG. **16C**, outer layers **840** (only a single outer layer **840** is illustrated in step **950**) and an edging material **550** may be employed. The edging material may be in the form of twine or rope and may be comprised of a variety of materials suitable for providing sufficient durability to the edge of the blade **30**, such as bulk molding compound of the type previously described, fiberglass, epoxy, resin, elastomer material, or any other suitable material. It has been found preferable, however, that fiberglass twine or rope be employed, such as the type manufactured by A & P Technology, Inc. of Cincinnati, Ohio. Each of the outer

layers **840**, as best-illustrated in FIG. **14E**, are also preferably comprised of two plies **520c** and **520d**. The outer layers **840** are preferably dimensioned to be slightly larger than the foam core elements **500a** and **500b** when mated together, as described at step **940**.

As described and illustrated at step **960**, the outer layers **840** are mated to the outer sides of the blade assembly illustrated at step **950**, such that a channel **860** is formed about the circumference of the blade assembly. The edging material **850** is then laid in the channel **860** about the circumference of the blade assembly to create the final uncured blade assembly. The uncured blade assembly is then inserted into a suitable mold configured to impart the desired exterior shape of the blade **30** (step **610** of FIG. **15A**). Heat is then applied to the mold for curing (step **620** of FIG. **15A**), after which the cured blade **30** is removed from the mold and finished for attachment (step **630** of FIG. **15A**). Notable is that the construction process described in relation to FIGS. **16A-C** has been found to be readily facilitated by the inherent adhesion characteristics of the employment of pre-impregnated fibers, layers, or plies, as the case may be.

FIG. **14F** illustrates a sixth preferred construction of the hockey stick blade **30**, which also comprises a plurality of inner core elements **500a** and **500b** overlain with plies **520a** and **520b**. As in the construction illustrated in FIG. **14D**, extending between the inner core elements **500a** and **500b** is a bead **590** of suitable materials (e.g., such as pre-impregnated fiber material, bulk molding compound, elastomer, etc.) that forms an internal bridge structure **530**. An edging material **550**, such as that discussed in relation to FIG. **14E**, may preferably be placed around the circumference of the blade **30**. In application, the incorporation of the bead of material may be achieved as discussed in relation to FIG. **14D**. Once the bead material is disposed between the core elements **500a** and **500b**, the remaining construction is similar to that discussed in relations to steps **950** and **960** of FIG. **16C**. Namely, (1) oversized outer layers are mated to the core elements having the bead material disposed there between, (2) the edging material **550** is wrapped around the circumference of the core members **500a** and **500b** in the channel created by the sides of the outer layers, and (3) the uncured blade assembly is loaded into a mold for curing and cured at the requisite temperature, pressure and duration.

FIG. **14K** illustrates a seventh preferred construction of the hockey stick blade **30** and FIG. **15B** details the preferred steps for manufacturing the blade **30** illustrated in FIG. **14K**. This construction method is also applicable for manufacturing one or more core **500** elements of the blade. In this preferred construction, bulk molding compound (i.e., non-continuous fibers disposed in a matrix material or resin base) of the type previously described is loaded into a mold configured for molding the desired exterior shape of the blade **30** or core element (step **700** of FIG. **15B**). With respect to the loading of the mold, it has been found preferable to somewhat overload the mold with compound, so that when the mold is sealed or closed, the excess compound material exudes from the mold. Such a loading procedure has been found to improve the exterior surface of the blade **30** or core element resulting from the curing process. Once the mold is loaded, heat is applied to the mold to cure (step **710**) and the cured blade **30** or core element is removed from the mold and finished, if necessary, to the desired appearance (step **720**) or otherwise employed as an inner core element.

It is to be understood that one or more of the foregoing core elements described in relation to the foregoing exemplary blade constructs may be comprised of various materials including one or more elastomer materials, as previously

discussed. Moreover, the core components may comprise discrete regions of different materials. For example, the core may be comprised of region formed of elastomer material and one or more other region formed of: foam, fibers or filaments disposed in a hardened resin or matrix material, wood or wood laminate, and/or bulk molding compound.

FIG. **14G** illustrates a preferred embodiment of a hockey blade **30** having a core comprising alternating layers of a “elastomer” material. Overlying the elastomer the layers of elastomer materials or interposed there between are layers formed of one or more of the following materials, fibers disposed in a hardened resin matrix (e.g., composite), wood, wood laminate, foam, bulk molding compound, or other suitable material. While any of these materials may be employed to alternate with the elastomer material, fibers disposed within a hardened resin matrix has been found to be suitable, and will therefore be described below for ease of description. FIG. **14G** depicts four composite layers **510** alternating with three elastomer layers **500a-c**. It is to be understood that a greater or lesser number of each type of layer may be employed to meet given performance requirements. Each of the elastomer layers may be comprised of the same elastomer material or a different elastomer material. In addition, one or more elastomer layers may comprise a mixture of more than one elastomer material or a compilation of multiple layers of different elastomer materials.

Each composite layer **510** preferably comprises two to eight fiber plies, more preferably two to four fiber plies, to provide desired strength to the blade **30**. The number of plies employs may vary given the desired performance and the characteristics of the fibers that comprise the plies. In FIGS. **14G-14J**, each composite layer **510** is shown as a single continuous layer, for ease of illustration, but it is to be understood that each composite layer **510** preferably comprises more than one fiber ply. By alternating layers of composite and elastomer material in the core, the strength and elasticity of the blade **30** may be varied to uniquely effectuate the performance and feel characteristics of the blade **30**.

Fiber plies pre-impregnated with resin or other suitable matrix material, as described above, are particularly suitable for constructing the composite layers **510** of the embodiments shown in FIGS. **14G** and **14J** (described below). This is so, because those layers traverse internally within the blade and are separated by the interposed elastomer layers—hence injection of resin into each of the alternating composite layers using a traditional RTM process may pose a significant hurdle to manufacturing the blade with controlled or consistent tolerances. Pre-impregnated plies, on the other hand are formed with the desired resin matrix in place, which thereby facilitates control over the distribution of the resin matrix for appropriate encapsulation of the fibers that are to be disposed therein. In addition, the tackiness of pre-impregnated tape plies, previously discussed are conducive to preparation of the pre-cured assembly in as much as they facilitate alignment and adhesion between the core components and the outer wall components of the blade assembly prior to curing. Thus, the use of pre-impregnated composite layers **510** is particularly preferred in these embodiments.

FIG. **14H** illustrates an alternative preferred embodiment wherein the core comprises a continuous elastomer material **500a** encased within a plurality of fiber plies **510** disposed in a hardened resin matrix. Employment of a single continuous core element of elastomer material **500a**, resiliency, elasticity as well as other physical properties derived from the given elastomer material employed may be particularly emphasized in the blade **30**.

FIG. 14I illustrates the blade construction of FIG. 14H having a rib or bridge structure 530 of composite material, or other suitable material as described above, extending from a composite layer inside the front face 90 of the blade 30 to a composite layer inside the rear face of the blade 30, in a manner similar to that described with regard to FIGS. 14D-14F. The bridge structure 530 is capable dispersing or distributing loads or impacts applied to the blade 30 (e.g., by a hockey puck) from the front face 90 to the rear face of the blade 30, as well as adding strength to the blade. FIG. 14J illustrates the blade construction of FIG. 14G having a similar bridge structure 530 extending through the alternating layers of composite and elastomer materials. The bridge structure 530 preferably extends from a composite layer inside the front face 90 of the blade 30 to a composite layer inside the rear face of the blade 30, as described above.

In an alternative construction, the core of the blade 30 may include foam, such as EVA foam or polyurethane foam, in combination with and/or surrounding one or more elastomer core elements. The foam core element may be disposed between elastomer core elements and an inner and/or outer (the layers that form the front or back faces of the blade) composite layers. For example the foam core element may be disposed adjacent to the composite front and/or back faces of the blade formed of fibers disposed in a hardened resin matrix and an elastomer core element may be disposed more internally thereto. Another example of such a construction may be comprised of a foam core element disposed at or near the top and/or bottom portions of the blade 30 and an elastomer core element disposed vertically intermediate thereto. Alternatively, the elastomer core elements may be layered either horizontally or vertically or otherwise combined with foam throughout discreet or continuous portions of the blade 30. The formation of a core comprising foam and elastomer elements, provides the additional capability of obtaining the benefits discussed herein relating to those materials and thereby provides additional capability of manipulating the desired performance and feel of the blade 30.

FIGS. 18A and 18B illustrate alternative blade constructions in which the core of the blade 30 comprises a matrix or resin material 1500, surrounded by a resilient or elastic material 1510, such as natural rubber, silicone, or one or more other elastomer material described herein. The resilient or elastic material 1510 may comprise the outer surfaces of the blade, as illustrated in FIG. 18A, or it may be overlain by one or more additional layers of composite material 1520, as illustrated in FIG. 18B. By overlaying a matrix or resin material with a elastomer material, the resilience and elasticity of the blade 30 may be further modified to meet desired performance and feel requirements.

It is to be appreciated and understood that shafts 20, illustrated in FIGS. 1-2 and 5-6, may be constructed of various materials including wood or wood laminate, or wood or wood laminate overlain with outer protective material such as fiberglass. Such a shaft 20 construction, in combination with any of the blade constructions described herein, results in a unique hybrid hockey stick configuration (e.g., a traditional "wood" shaft attached to a "composite" blade), which may provide desired "feel" characteristics sought by users. Additionally, one or more of the elastomer materials described herein may be employed as core elements in portions of the shaft, as well as the hosel, and/or the adapter section, to further modify the feel and performance characteristics of the blade, shaft, and stick.

In addition, it should also be understood that while all or a portion of the recessed tongue portion 260 of the heel 140 may be comprised of a foam or elastomer core overlain with

plies or groups of fibers disposed in a matrix material; it may also be preferable that all or a portion of the recessed tongue portion 260 of the heel 140 be comprised without such core elements or may be comprised solely of fibers disposed in a hardened matrix material. Such a construction may be formed of plies of unidirectional or woven fibers disposed in a hardened resin matrix or bulk molding compound. Employment of such a construction in part or throughout the tongue 260 or joint between the blade and the joined member (e.g., shaft or adapter member) is capable of increasing the rigidity or strength of the joint and/or may provide a more desirable flex as was described in relation to the internal bridge structure(s) 530 described in relation to FIGS. 14A-14J.

While there has been illustrated and described what are presently considered to be preferred embodiments and features of the present invention, it will be understood by those skilled in the art that various changes and modifications may be made, and equivalents may be substituted for elements thereof, without departing from the scope of the invention.

In addition, many modifications may be made to adapt a particular element, feature or implementation to the teachings of the present invention without departing from the central scope of the invention. Therefore, it is intended that this invention not be limited to the particular embodiments disclosed herein, but that the invention include all embodiments falling within the scope of the appended claims. In addition, it is to be understood that various aspects of the teachings and principles disclosed herein relate configuration of the blades and hockey sticks and component elements thereof. Other aspects of the teachings and principles disclosed herein relate to internal constructions of the component elements and the materials employed in their construction. Yet other aspects of the teachings and principles disclosed herein relate to the combination of configuration, internal construction and materials employed therefor. The combination of one, more than one, or the totality of these aspects define the scope of the invention disclosed herein. No other limitations are placed on the scope of the invention set forth in this disclosure. Accordingly, the invention or inventions disclosed herein are only limited by the scope of this disclosure that supports or otherwise provides a basis, either inherently or expressly, for patentability over the prior art. Thus, it is contemplated that various component elements, teachings and principles disclosed herein provide multiple independent basis for patentability. Hence no restriction should be placed on any patentable elements, teachings, or principles disclosed herein or combinations thereof, other than those that exist in the prior art or can under applicable law be combined from the teachings in the prior art to defeat patentability.

What is claimed is:

1. A cured composite blade for a hockey stick comprising: an elongated member extending longitudinally from a tip section to a heel section and vertically from a top section to bottom section to form a front facing wall that defines an outer front face of the blade and a generally opposing back facing wall that defines an outer back face of the blade;

said front and back facing walls are spaced apart at their mid-sections and merge together at their perimeter edges to define a cavity there between and are formed of one or more plies of fibers disposed in a hardened resin matrix material, said outer front face and outer back face defining a cross-sectional area of the blade that extends generally perpendicular thereto; and

two or more inner core elements encased within the front and back facing walls, wherein a first inner core element is formed of a different material than a second inner core

29

element, and wherein the first inner core element is positioned closer than the second inner core element to the front facing wall, and wherein the first inner core element is formed of a non-foam elastomer material and the second inner core element is formed of a foam material.

2. The hockey stick blade of claim 1, having a third inner core element residing adjacent to the second inner core element.

30

3. The hockey stick blade of claim 2, wherein the third inner core element is formed of one or more plies of fibers disposed in a hardened resin matrix material.

5 4. The hockey stick blade of claim 2, wherein the third inner core element resides in between the first and second inner core elements.

* * * * *