



US007941871B1

(12) **United States Patent**  
**Jorgensen**

(10) **Patent No.:** **US 7,941,871 B1**  
(45) **Date of Patent:** **May 17, 2011**

(54) **GARMENT WITH STRETCHABLE SECTION AND RELATED METHODS**

(76) Inventor: **Joey Jorgensen**, San Clemente, CA (US)

(\*) Notice: Subject to any disclaimer, the term of this patent is extended or adjusted under 35 U.S.C. 154(b) by 0 days.

(21) Appl. No.: **11/492,602**

(22) Filed: **Jul. 25, 2006**

**Related U.S. Application Data**

(63) Continuation of application No. 10/643,492, filed on Aug. 18, 2003, now abandoned.

(51) **Int. Cl.**  
**A41D 1/08** (2006.01)

(52) **U.S. Cl.** ..... **2/238; 2/228**

(58) **Field of Classification Search** ..... 2/79, 80, 2/401, 227, 228, 238, 69; 602/19  
See application file for complete search history.

(56) **References Cited**

**U.S. PATENT DOCUMENTS**

650,956	A *	6/1900	Scriven	.....	2/401
1,797,115	A *	3/1931	Atkinson	.....	2/401
2,250,218	A *	7/1941	Cadous	.....	2/401
2,344,375	A *	3/1944	Stephens	.....	450/104
2,561,312	A *	7/1951	Laszlo	.....	2/67
2,958,327	A *	11/1960	Geissmann	.....	450/101
2,983,924	A *	5/1961	Cohen et al.	.....	2/67
3,338,776	A *	8/1967	Blair	.....	428/88
3,512,532	A *	5/1970	Sutter	.....	450/98
3,894,542	A *	7/1975	Sacristan	.....	450/123
4,843,654	A *	7/1989	March	.....	2/227
4,862,523	A *	9/1989	Lipov	.....	2/409
4,946,453	A *	8/1990	Monson	.....	
5,010,596	A *	4/1991	Brown et al.	.....	2/228

5,201,074	A *	4/1993	Dicker	.....	2/70
5,210,877	A *	5/1993	Newman	.....	2/456
5,267,928	A *	12/1993	Barile et al.	.....	482/124
5,282,277	A *	2/1994	Onozawa	.....	2/69
5,465,428	A *	11/1995	Earl	.....	2/238
5,699,559	A	12/1997	Sano	.....	
5,737,773	A	4/1998	Dicker	.....	
5,742,936	A	4/1998	Tronc	.....	
5,829,058	A *	11/1998	Dicker et al.	.....	2/69
5,857,947	A	1/1999	Dicker	.....	
5,937,442	A *	8/1999	Yamaguchi et al.	.....	2/69
5,968,002	A *	10/1999	Morrisseau	.....	602/62
6,041,437	A *	3/2000	Barker et al.	.....	2/82
6,176,816	B1	1/2001	Dicker	.....	
6,186,970	B1 *	2/2001	Fujii et al.	.....	602/75
6,199,215	B1	3/2001	Biggerstaff	.....	
6,231,488	B1	5/2001	Dicker	.....	
6,243,879	B1 *	6/2001	Lyden	.....	2/227
6,363,538	B1 *	4/2002	Davis	.....	2/247
6,430,752	B1 *	8/2002	Bay	.....	2/228

(Continued)

**FOREIGN PATENT DOCUMENTS**

WO WO 02/47501 A1 \* 6/2002

*Primary Examiner* — Alissa L Hoey

(74) *Attorney, Agent, or Firm* — Eric Hanscom; Todd J. Langford

(57) **ABSTRACT**

The present invention is directed to a garment (such as a short, shirt, pants and other garments) having a stretchable section preferably of neoprene, that provides for improved comfort and wearability. The other panels or fabric portions of the garment may be constructed of a relatively less stretchable or even a relatively inelastic material, and the stretchable portion is positioned in an "area of flex" of the garment (so that the stretchable portion can "stretch" when the wearer rotates limbs extending into the garment). Related methods are disclosed for garment fabrication and the like.

**10 Claims, 5 Drawing Sheets**

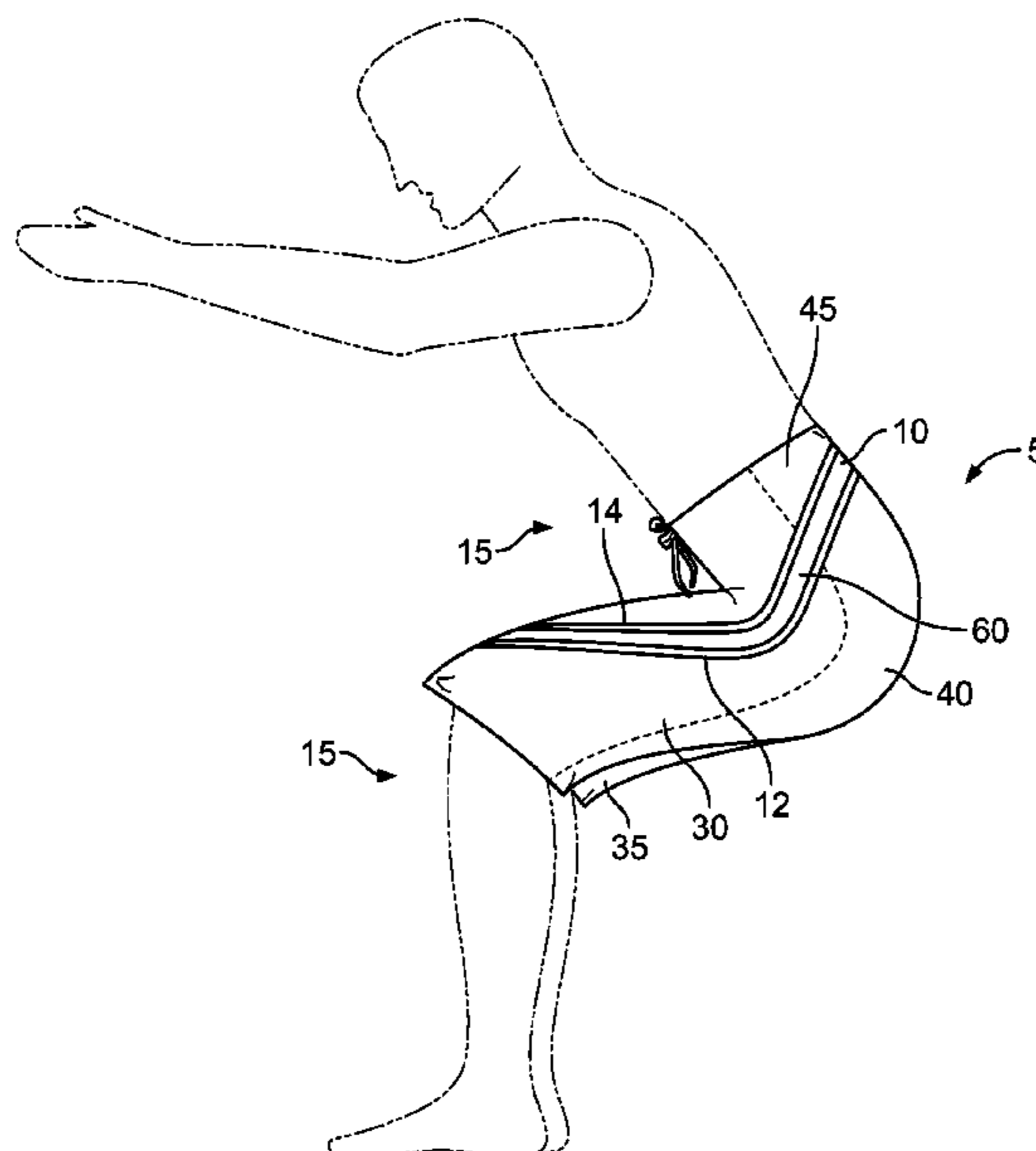

# US 7,941,871 B1

Page 2

## U.S. PATENT DOCUMENTS

6,454,628	B1 *	9/2002	Shunichirou	450/155	7,814,576	B2 *	10/2010	Nakazawa	2/227
6,526,584	B1	3/2003	Hunter		2003/0019014	A1 *	1/2003	Duran	2/239
6,684,410	B2 *	2/2004	Robinett et al.	2/228	2003/0028952	A1 *	2/2003	Fujii et al.	2/400
6,712,841	B2 *	3/2004	Gomez	607/114	2003/0208829	A1 *	11/2003	Ragot et al.	2/67
6,789,270	B1 *	9/2004	Pedrick	2/228	2004/0107479	A1 *	6/2004	Dicker et al.	2/227
6,874,337	B2 *	4/2005	Uno et al.	66/177	2005/0193461	A1 *	9/2005	Caillibotte et al.	2/69
D520,715	S *	5/2006	Ota et al.	D2/731	2006/0074365	A1 *	4/2006	Brown	602/24
7,074,204	B2 *	7/2006	Fujii et al.	602/75	2007/0067892	A1 *	3/2007	Oyama et al.	2/227
7,087,032	B1 *	8/2006	Ikeda	602/19	2008/0083055	A1 *	4/2008	Onda	2/455
7,093,306	B2 *	8/2006	Villalobos	2/227	2008/0194181	A1 *	8/2008	Sudo et al.	450/123

\* cited by examiner

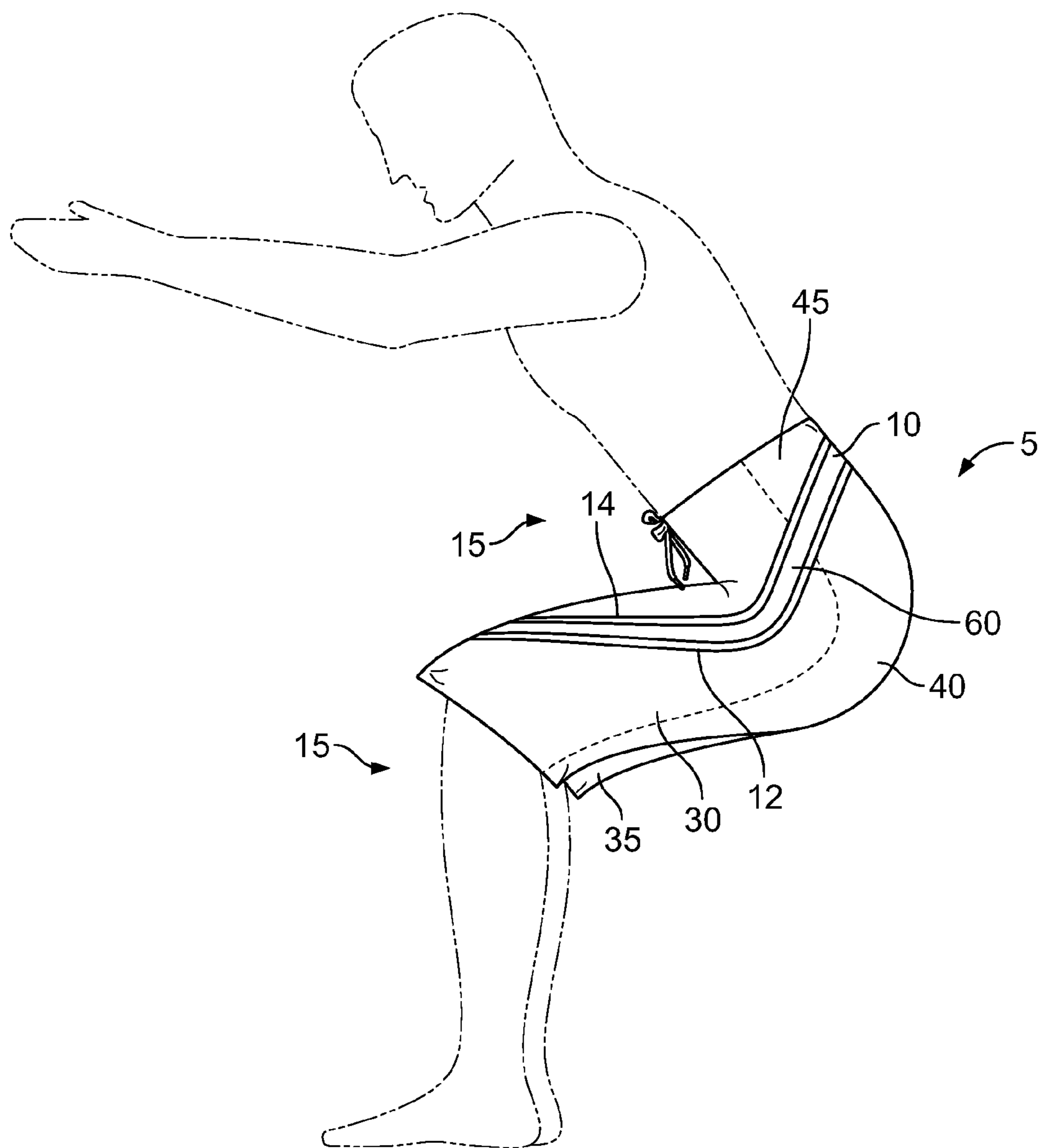

Fig. 1A

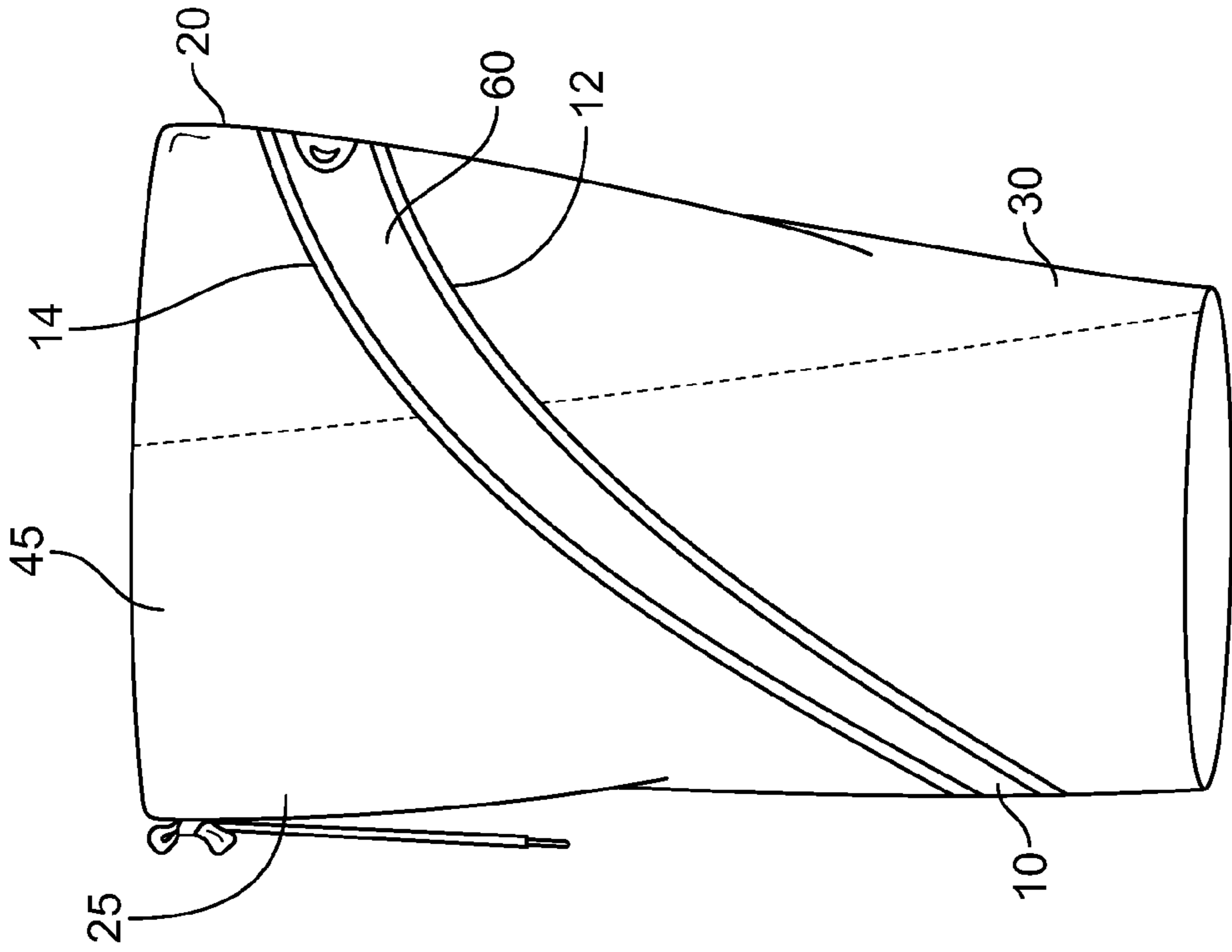

Fig. 1C

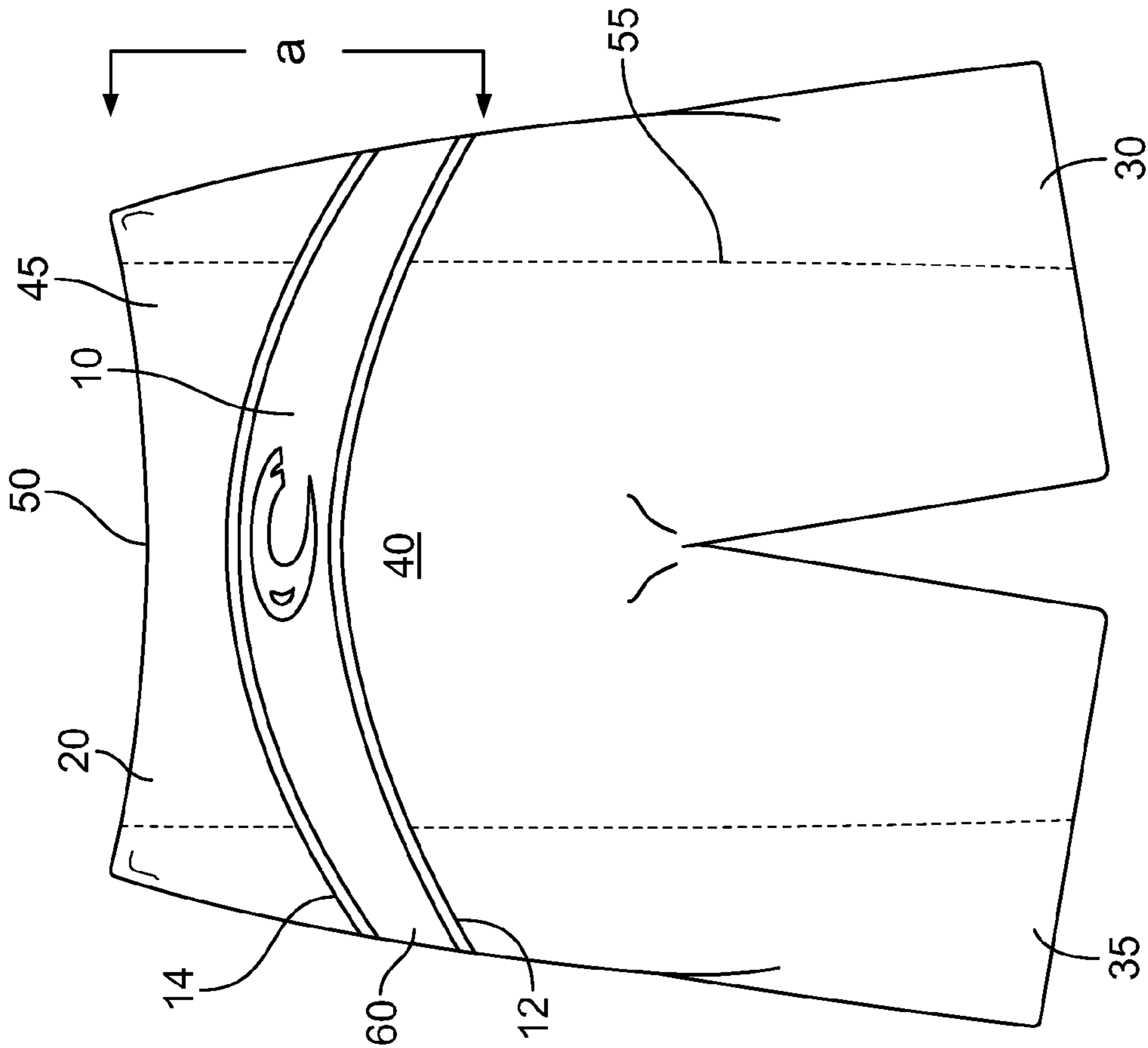

Fig. 1B

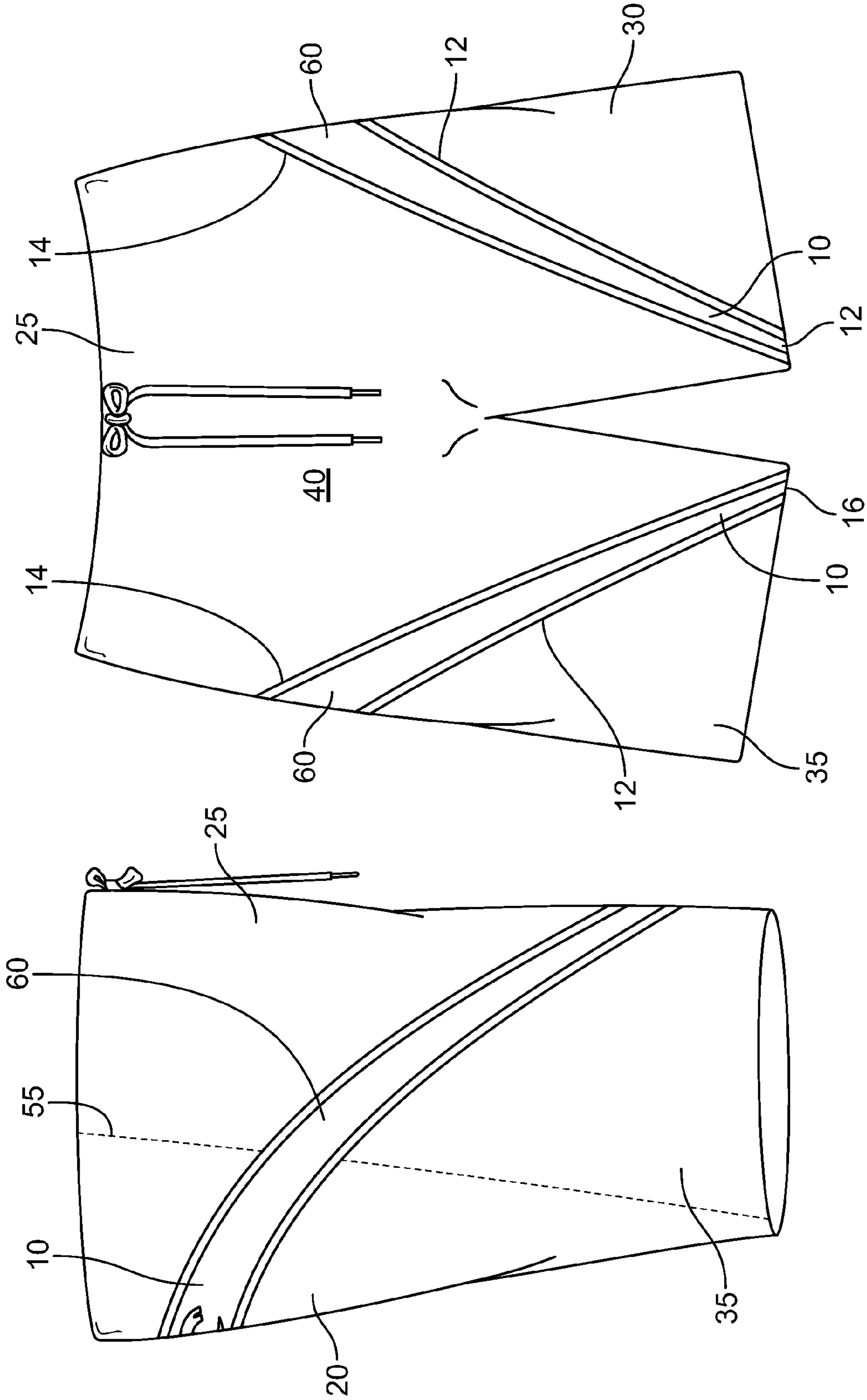

Fig. 1E

Fig. 1D

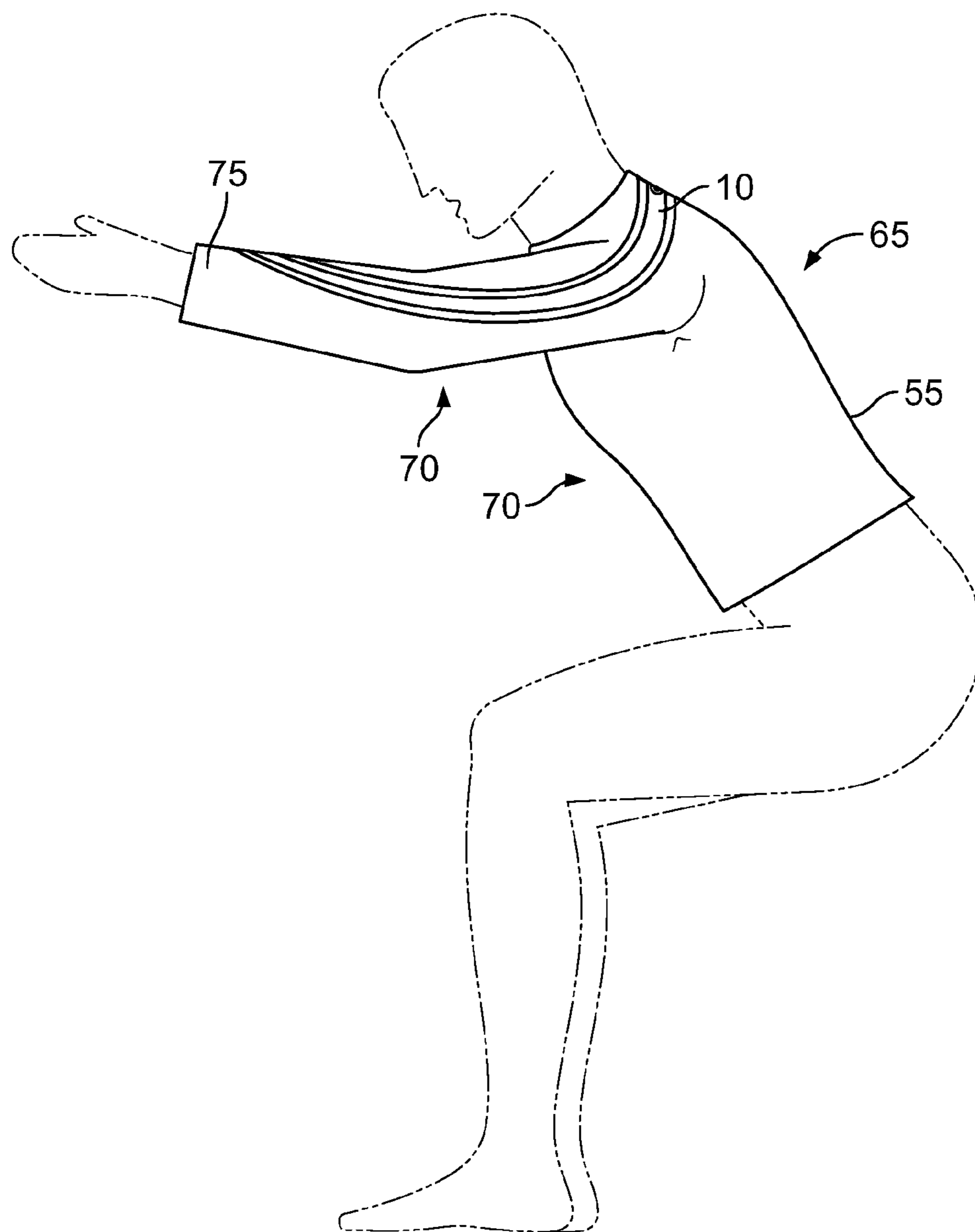

Fig. 2A

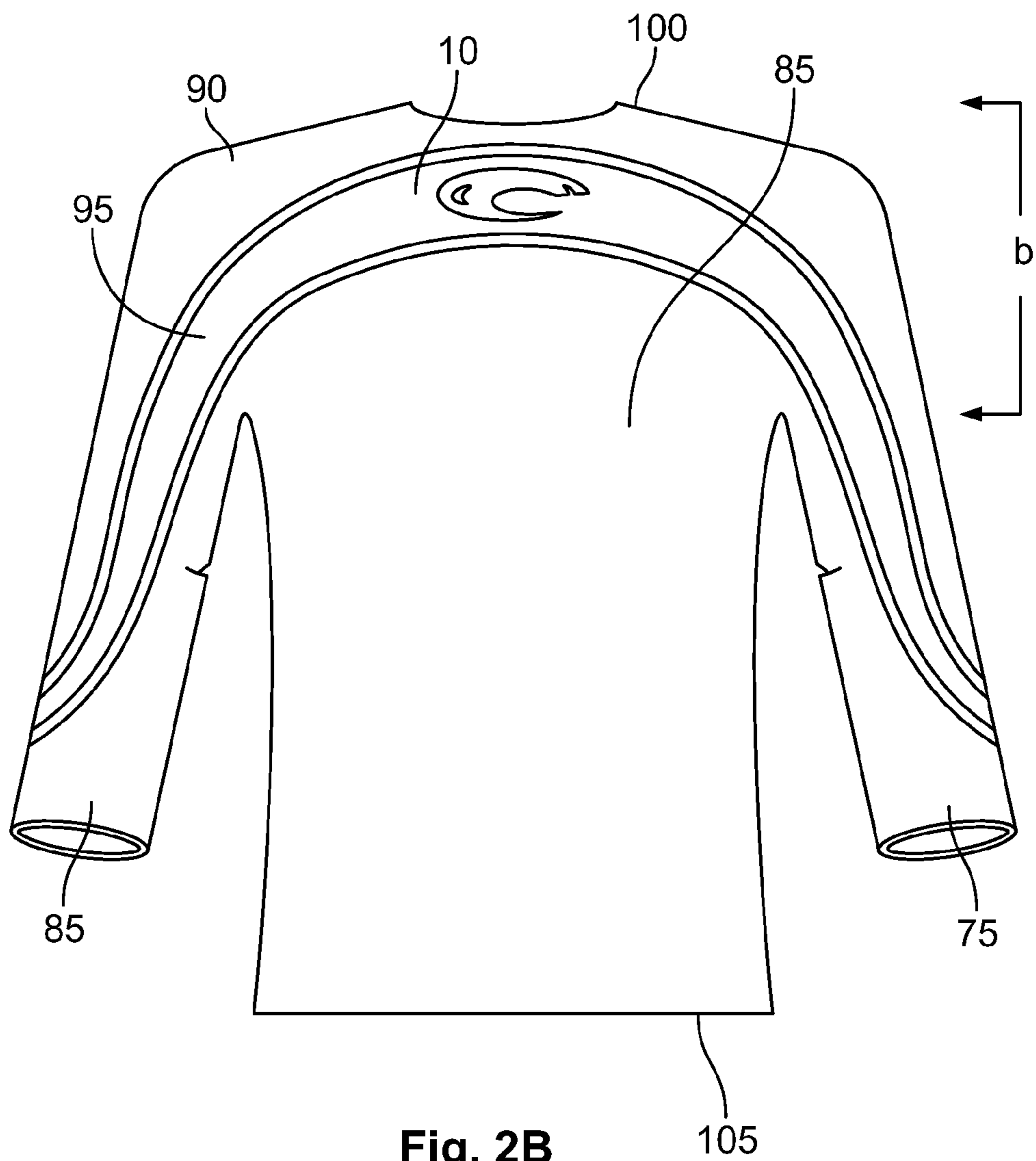

Fig. 2B

## GARMENT WITH STRETCHABLE SECTION AND RELATED METHODS

This application is a continuation U.S. patent application Ser. No. 10/643,492, filed on Aug. 18, 2003 now abandoned. Priority to the aforementioned application is hereby expressly claimed in accordance with 35 U.S.C. §120 and any other applicable statutes. The contents of the aforementioned application, and of each U.S. Patent and other reference, if any, cited in that and/or in this application, are hereby incorporated herein by reference.

### FIELD OF INVENTION

The present invention relates generally to garments. More particularly, the present invention relates to a garment having a stretchable section that provides improved “wearability” (including improved comfort, flexibility, and/or durability). Although the invention is useful in a wide range of clothing and applications, it is especially useful for garments intended for physical activity, such as board shorts and the like. In contrast to other athletic garments having stretchable sections that are typically snug or form-fitting, the present invention is especially useful for relatively looser clothing styles such as those commonly worn during surfing or similar activities.

### BACKGROUND OF INVENTION

Clothing comes in a wide variety of styles and configurations. There are numerous garments and clothing options, each of which may be suitable for a variety of occasions and activities. The style, size, and configuration of an individual’s clothing (including cut, color combinations, and fabric/material type, for example) can present an image for the rest of the world to scrutinize and assess. As such, clothing can provide individuals a means of self-expression of their own style and uniqueness.

In addition to “style” considerations, however, many people also consider other factors in selecting their clothing or garments. Among other things, certain clothing can be appropriate for certain activities, and the wearability, comfort, and material durability or “life” of the garment can be factors. The feel or texture of certain fabrics against the skin can be important (e.g., many people prefer the tactile feel of cotton fabrics rather than wool), as can the temperature transmission properties of the clothing/fabric (e.g., silk may be a popular choice as a warm weather fabric due to “breathability,” or may be used in other applications to help provide an insulating layer against cold).

In addition, how the garment moves in relation to movement of the wearer’s body can be important. In some instances (including, for example, many athletic or physical activities), it may be desirable to have a garment that fits relatively loosely and/or does not unnecessarily restrict the wearer’s movement. Among other things, such restrictions may undesirably limit the wearer’s degree of movement, impeding their athletic/physical performance and/or enjoyment.

At least two methods can be used to provide desired “comfort” or freedom of movement in clothing: (1) the clothing can be designed entirely or from substantially all “stretch” material, so that it fits snugly to the body at all times but is capable of expanding or contracting with the wearer’s body movement; or (2) the clothing can be designed to be loose fitting, so that the body moves relatively independently from the clothing.

In the form-fitting category are certain activities such as aerobics, bicycling, etc. As indicated above, current fashion/function in those activities includes garments (shorts/leotards/bodysuits/etc.) fabricated all or mostly from “stretchy” material, so that the garment/fabric is “stretched” to some degree even when the wearer is at rest. Stretchable fabrics (such as spandex or LYCRA®, for example) typically can expand but have material memory that urges the garment to its original shape and size (or to a snug fit on the wearer’s body) once the stretching force is removed (e.g., once the wearer returns to a resting posture).

Such restrictions on movement also can occur, however, (at least to some degree) even if the garment is “loose” rather than form fitting or snug on the wearer. By way of example, for activities such as surfing, wakeboarding, and/or skateboarding, “loose-fitting” board shorts and other clothing typically are worn in a relatively baggy style (not snug fitting). Commonly, such clothing is suspended on the wearer’s body only (or primarily) at the wearer’s waist or otherwise (via buttons, a drawstring, Velcro, or other suitable fastening means). For such activities, persons typically do not choose to wear tight clothing, except when the weather and/or water is so cold as to make desirable the wearing of wetsuits or the like.

Similar considerations exist for “all in one” style garments, such as wetsuits or the aforementioned bodysuits, and perhaps to an even greater degree. Whether fabricated from stretchable materials or in a “loose” style, the fact that the wearer’s arms and legs may simultaneously be “pulling” on the garment during certain body movements can add to the amount of restriction the wearer may experience from the garment.

Substantial or repetitive body movement (such as can occur during exercise or certain physical activities) also can place stress on a garment’s fabric and seams. In certain situations or at sufficient stress levels, this can result in tears or rips along the seam(s) or body of the fabric, and/or in unsightly deformation or bulging of the garment material. This can occur even with the aforementioned all-stretch garments, but certainly with the loose-fit style clothing.

Moreover, despite their benefits (such as those mentioned above), some stretchable fabrics can be relatively more delicate (less rugged) than other garment materials. Certain activities, or at least certain areas of garments for those activities, conventionally require a relatively tougher material, to withstand the wear and tear of the activity and/or to at least somewhat protect the wearer. Accordingly, there can be a trade-off in garment design between (1) relatively tougher (and typically less stretchable) material, and (2) the aforementioned “comfort” or freedom of movement.

Garments (such as bicycle shorts) made substantially or completely from such relatively stretchy materials can also be inappropriate or undesirable for certain applications. Among other things, they can be very form fitting and/or relatively transparent (which a modest wearer may not want), and may tend to ride up or bind or slip off of certain areas of the wearer’s body (especially during the movements of exercise and the like).

As new and more extreme sports evolve, and as people take existing sports and activities to further extremes, clothing designers continue to address issues of this nature and try to balance new and existing stretchability/toughness quandaries. Many sports or activities further complicate the process because they include a substantial element of moisture, in the form of the wearer’s perspiration, exposure to the elements (ocean/surf/swimming, rain, etc.), or both. Among other things, “board sports” (including surfing, wakeboarding,



snowboarding, etc.) continue to evolve, and the style and “comfort” demands and desires for appropriate garments/clothing evolve as well.

### SUMMARY

The present invention is directed to garments having one or more stretchable sections positioned in an otherwise relatively less stretchable (or “non-stretchable”) garment. Among other things, the one or more stretchable sections preferably provide improved wearability when worn by the user. The relatively “more stretchable” section or sections preferably are constructed of neoprene, although other materials such as spandex, LYCRA®, lined neoprene (an “ultraflex” material that provides at least 4-way directional stretch capabilities to the stretchable material), or the like may be used. The relatively more stretchable section(s) preferably are selectively shaped and positioned on an article of clothing in an area where the wearer’s body movement may cause stress to the garment material. The relatively more stretchable material facilitates garment expandability, thus providing for improved garment wearability, increased wearer comfort, and extended garment life. Among other things, the inventor is not aware of any prior art that combines neoprene panels within a garment of any type of non-neoprene stretch material.

For certain garments and applications (e.g., board shorts), the relatively stretchable or more stretchable fabric section can be provided in a substantially arcuate elongated strip, passing across the buttocks of the garment. The substantially arcuate shape allows the stretchable material to be positioned along areas of the garment adjacent the wearer’s lower trunk/torso and lower extremities, so that the stretchable fabric section can reduce stress on other portions of the garment material (which might be caused, for example, by the wearer’s body movements such as bending or twisting at the waist, extension of the leg, and/or flexion of the hip or knee).

In some of the many other embodiments of the invention, the stretchable material can be positioned along areas of the garment adjacent the wearer’s upper trunk and arms (areas where the garment material similarly may be stressed due to the wearer’s body movements). The precise shape, size and positioning of the more stretchable fabric section can vary widely, depending on many factors, as described above (including the specific activity, the anticipated movements of wearers, general comfort considerations, etc.).

By way of further example, the relatively stretchable material section may extend along a length of (or across) the torso and/or the arms or legs of the garment, and may be continuous or in separate pieces at separated locations on the garment. Alternatively, the stretchable section may extend along or across the entire length of the torso and/or the arms or legs of the garment, extending even from edge-to-edge of the garment.

Stretchable material located between relatively less-stretchable garment material (with the stretchable and less-stretchable portions collectively forming the body of the garment) allows the garment (even if “loose fitting”) to expand or “give” with body movement. Among other things, and as mentioned above, this can result in increased garment “life” because there is no sliding or dragging of garment material, i.e., no garment material frictional force to overcome.

Strategic areas for positioning the stretchable material section(s) would include (by way of example and not by way of limitation) the buttocks, shoulder, elbow, wrist, leg, hip, ankle, and/or knee areas of the garment. Among other things,

those “flexing” areas of the wearer’s body are likely to benefit from adjacent “stretchable portions” built into the garment.

Moreover, although prior art 2-way stretch materials have been used in certain garments (for example, board shorts), the invention’s use of dissimilar stretch materials within a single garment (such as the inclusion of a stretchier (e.g. 4-way stretch neoprene) panel within a single such garment brings a heightened degree of comfort, flexibility, and fashion.

### DETAILED DESCRIPTION OF THE DRAWINGS

FIG. 1A is a side elevation view of a preferred embodiment of the invention, showing a garment **5** adapted to be worn by a person (shown in phantom, in a flexed position) having a relatively stretchable section **10** positioned within relatively non-elastic or less stretchable material.

FIG. 1B is a back elevation view of the garment **5** of FIG. 1A, with the garment shown in its normal, non-stretched configuration.

FIG. 1C is a side elevation view of the garment **5** of FIG. 1B, from the wearer’s left side.

FIG. 1D is a side elevation view of the garment **5** of FIG. 1B, from the wearer’s right side.

FIG. 1E is a front elevation view of the garment **5** of FIG. 1B.

FIG. 2A is a side elevation view of one of the many alternative embodiments of the invention, showing a garment **55** similar to garment **5** of FIGS. 1A-E, but adapted to be worn on a person’s upper torso.

FIG. 2B is a back view of the garment **55** of FIG. 2A, with the garment shown in its normal, non-stretched configuration.

### DETAILED DESCRIPTION

As illustrated in FIGS. 1A-E, a preferred embodiment of the invention includes a garment **5** having a stretchable section **10** forming an integral portion of the garment. The stretchable section preferably is fabricated from a stretchable material, such as elastomeric foam, spandex, LYCRA®, neoprene or a neoprene-type material known as “ultra-flex”, or a similar type of material. For board shorts, the stretchable material is preferably stretchable neoprene having sufficient elasticity to allow the repeated stretching described herein during the wearer’s various body movements and to return to its original unstretched condition.

Also preferably, the remaining portions of the garment **5** are fabricated from any suitable relatively less-stretchable or non-stretchable materials, such as a polyester blend or the like. Other materials include, without limitation, cotton, polyester, nylon, or blends thereof. Although the preferred embodiment includes a relatively more stretchable section **10** within a garment principally fabricated from a less stretchable material, the precise ratio of more to less stretchable materials within the garment can vary widely.

In the embodiment of FIGS. 1A-E, the stretchable section **10** preferably is provided as an elongated strip having first and second longitudinal edges **12** and **14** that are generally parallel to a longitudinal axis of said strip. Among the many alternative embodiments of the invention, however, the more stretchable section or insert can take a wide variety of shapes and sizes other than those shown in the drawings, with greater tapering, rounded shapes, etc.

The strip **10** preferably also includes first and second ends **16** and **18** (FIG. 1E) at the extremities of the longitudinal axis of the strip. The first end **16** preferably is positioned to form a portion of an edge of the garment’s leg **35**, and the strip itself preferably traverses from there upwardly and around the back

5

of the garment **5**, terminating in the second end **18** forming a portion of an edge of the garment's other leg **30**.

The first and second longitudinal edges **12** and **14** preferably are attached (via sewing, gluing, welding (including seamless welding), melting, weaving, or any suitable means or method) to corresponding/confronting edges of the relatively less-stretchable garment portion.

As indicated above, persons of ordinary skill in the art will understand that the specific shape(s) and location(s) of the stretchable section(s) **10** within the garment **5** (as well as the specific nature, relative stretchability, color, and other characteristics of the stretchable and less-stretchable or non-stretchable sections of the garment **5**) can vary depending on the application for which the garment may be intended.

In the embodiment of FIGS. 1A-E, the preferably relatively more stretchable material **10** is illustrated as having a substantially arched or arcuate shape, and as extending from a lower front edge of the board shorts **5** continuously around the back of the shorts and back down the opposite leg to its edge. Wherever the stretchable material **10** is located on the garment, it preferably can stretch in response to the wearer's movements (such as the when the wearer moves into the position illustrated in FIG. 1A), permitting increased flexibility and expansion of the garment and less resistance to the wearer in various directions during certain movements.

In addition (for embodiments such as illustrated in FIGS. 1A-E), because the stretchable section **10** bisects or extends completely "across" the garment **5** in that manner, the entire garment can shift in response to the wearer's movements in ways not possible without the stretchable portion **10**. Specifically (and in addition to conventional bending and/or expansion of the stretchable section **10** in various directions), the opposing edges of the relatively less-stretchable portions of the garment adjacent the stretchable section **10** (i.e., the edges that are operatively sewn or otherwise joined to the edges **12** and **14** of the stretchable section **10**) are relatively "free" (within the limitations of the stretchable section **10**) to "shift" with respect to each other.

As indicated above, some of the many other embodiments of the invention (not shown) can include differing shapes and locations of the stretchable portion **10**, and/or multiple (distinct/separate) stretchable portions **10** within the same garment **5**. Among those many alternatives would be ones similar to that illustrated in FIGS. 1A-E, but having the elongated strip **10** extending from somewhere other than the front edge of a first leg to the front edge of the opposite leg. In such embodiments, the ends **16** and **18** could, among other things, terminate completely within the body of the garment itself (rather than extending to one or more of its edges), form a continuous loop around the wearer's torso and/or the wearer's legs (or one of them), or have some other position within the garment. In any such embodiments in which the stretchable portion did not completely bisect the garment, some degree of the "shifting" mentioned above may not exist in the garment (as compared to bisected garment embodiments), but many benefits of the invention will still be present in such garments.

Although the stretchable portion **10** is illustrated as symmetrical with respect to the right and left sides of the wearer's body, alternative embodiments would include not having such symmetry regarding the strip **10** or otherwise.

The stretchable material section can be positioned within the article of clothing in an area where body movement may cause stress to the garment material to reduce or eliminate the stress. The stretchable material facilitates ease of garment material expandability, thus providing for improved garment wearability by increasing wearer comfort and garment life.

6

In FIGS. 1A-1E, the garment **5** has a stretchable section **10**, and is adapted to be worn about a portion of the person's lower trunk/torso and lower extremities or legs **15**. The alternative embodiment illustrated in FIGS. 2A-B illustrates the invention as it may be incorporated within a shirt or top **55**. Among the many other alternative embodiments of the inventions are tops with short sleeves (rather than the long sleeves of FIGS. 2A-B), unibody garments (having both legs and arms within a single garment), pants/shorts/bottoms that incorporate straps extending over the wearer's shoulders to held retain the garment on the wearer, and many others.

As shown in FIGS. 1A-E, garments embodying the invention may include shorts **5** such as board shorts or surf shorts that are typically supported at approximately the wearer's waist and extend to about the knees. Such shorts could alternatively have legs that terminate higher or lower on the wearer's legs. Pants (not shown) may similarly incorporate one or more relatively stretchable sections **10**, and the term short or pants is not intended to be strictly limited. Among other things, the invention may be used in any garment **5** that may be worn about or cover a portion of the lower trunk/torso including any portion of the legs **15** of a person's body. Alternative terms for such a garment **5** may include trousers, slacks, knickers, breeches, board shorts, jams, etc. The aforementioned garments **5** may be used by the wearer for any event or activity in which the wearer may derive the benefits of the present invention, as described herein, or simply for relative comfort as compared to wearing clothing that does not incorporate the invention.

Stretchable fabric selectively positioned in a garment of relatively less or no stretchability can provide the added benefit of relieving fabric or seam stress (such as along the edges **12** and **14**, or at other seams within the stretchable material **10** or the less-stretchable material), by allowing the garment to expand or "give" with body movement. This in turn can result in extended garment "life."

FIG. 1C illustrates the garment **5** having a first leg or section **30** adapted to receive within and permit to pass therethrough one extremity (such as a leg) of a person. In one embodiment, the first section **30** of the garment **5** is a covering such as a pant leg or a leg that is associated with the corresponding pants or short. As described herein, such a covering **30** may begin approximately at the wearer's waist and have a length that may vary depending on whether the garment **5** is intended for use as a short or pants. For example, a leg covering for a short may cover only a small length of the thigh, or the leg covering may cover the entire length of the thigh from the waist to an area about the knee. In one embodiment, the present invention has an outseam (measured from the top of the waist to the bottom of the garment) of approximately 22 inches on a size 32 waist garment (other waist sizes can have similar proportions, or may differ in their length/waist ratio). Likewise, a leg covering for pants may extend a length from approximately the waist to mid calf "pedal pusher", or the leg covering may extend the entire length of the leg to the ankle or beyond.

In addition, as described herein, the first section **30** may be constructed of a single panel or multiple panels depending on garment style, material, and intended application. Thus, a first section or leg covering **30** is a term used to describe the entire portion of the garment **5** that is generally considered to cover that portion of the leg or lower extremity **15** intended to be covered. In the context of the first section being a leg covering, the extremity **15** will be a leg of a person. As with most shorts or pants, the leg covering permits a leg to be received and to pass therethrough, as shown in FIG. 1A.

Likewise, as shown in FIG. 1D, the garment **5** further includes a second section **35** adapted to receive within and permit to pass therethrough the opposite leg or extremity of the person. Therefore, continuing with the description of the aforementioned embodiment as being shorts or pants, the second section **35** would, similar to the first section **30**, be a covering such as a pant leg or leg of a short and the opposite extremity would be a leg of the person, but not the leg received by the first section **30**. Thus, when describing an extremity used with a particular garment **5** it will be understood that the opposite extremity is of the same character, e.g., if one extremity is a leg, then the opposite extremity is the other leg, or, as described herein, if one extremity is an arm, then the opposite extremity is the other arm.

Preferably, and as illustrated in FIGS. 1A-E, the first section **30** and the second section **35** (leg coverings) are substantially similar. Thus, for ease of describing the present invention, it will be understood that except for differences specifically described herein, the description of the first section **30** of the garment **5** at least generally applies to the second section **35** of the garment **5**.

The garment **5** can be further described as including a third section **40** adapted to receive a portion of a person's body such as the torso. The third section **40** joins together the first section **30** and the second section **35**. In one embodiment, as shown in FIGS. 1B and 1E, the third section **40** is the portion of the short or pants that is broadly considered to cover the lower trunk/torso of a person including the buttocks and groin areas. In this regard, the third section **40** may be described as having a back portion **20** connected to a front portion **25**. The back portion **20** of the third section **40** is used to cover that area of the body generally considered the buttocks, and the front portion **25** of the third section **40** is used to cover that area of the body generally considered the groin. The third section **40** has a top area **45**, formed by the back portion **20** and the front portion **25**, generally positioned on the garment **5** such that when worn by the user the top area **45** contacts the user's body generally along the waist and hip region. Thus, as shown generally by arrows "a" in FIG. 1B, the top area **45** of the third section **40** may be considered to extend from a top edge **50** of the garment **5**, near the wearer's waist, to approximately six inches below the top edge **50**. Regardless of that dimension, the preferred embodiment of FIGS. 1A-E preferably includes the stretchable section **10** positioned so as to pass across and over the buttocks (whether or not within six inches of the top of the garment) and thereby permit the desired flexing of the wearer's legs described herein.

As shown in FIGS. 1A-D, the third section **40**, the first section or leg **30**, and the second section or leg **35** can be formed by multiple pieces of fabric sewn or otherwise joined together along seams **55**. As shown, the seams **55** and the multiple pieces of fabric between the seams can cross through one or more of the third section **40**, the first section or leg **30**, and the second section or leg **35**.

In alternative embodiments (not shown), the number and location of any such seams can vary in any suitable manner, to provide a useful, comfortable, functional garment. Seams **55** or similar "joints" in the garment may (again, in alternative embodiments) be joined by thread, VELCRO, button(s), snap(s), or any suitable securing means. As indicated above, positioning of the seams **55** can vary depending on a variety of factors, including (for example) the garment style, garment material, and the intended use of the garment **5**. As such, persons of ordinary skill in the art will understand that the terms first section **30**, second section **35**, and third section **40** are used to describe various portions of the garment **5** relative to each other in terms of how they are positioned when worn

on the body, and not necessarily defined by how or where each are joined to the other garment **5** sections.

For example, the first **30**, second **35**, and third **40** sections may be formed from a single piece of material or fabric joined substantially near the groin area such that the third section **40** is contiguous with the first section **30** and the second section **35**. Thus, defining an exact point on the garment **5** where the first section **30**, second section **35**, and third section **40** begins or ends is difficult unless garment **5** positioning on the wearer's body is used as a reference. As such, the first section **30** and second section **35** are each generally positioned to cover the wearer's legs and the third section **40** is generally positioned about the wearer's waist and intended to cover the buttocks and groin areas.

The stretchable section **10** may also be described as a fourth section **60** constructed of a stretchable material **10**. As indicated above, the garment material (used to construct the first **30**, second **35**, and third **40** sections; in contrast to the stretchable material **10** used to construct the fourth section **60**) may be of any type material/fabric other than the stretchable material/fabric **10** used to construct the fourth section **60**.

Preferably, the fourth section **60** is at least partially positioned along or near the top area **45** of the garment **5** formed by the back portion **20** of the third section **40**. In the preferred embodiment, the fourth section **60** also extends continuously along a length of the first section or leg **30** and the second section or leg **35** and thus, the fourth section **60** has a substantially arcuate shape within the assembled garment. In other words, and as shown in FIGS. 1B-1E, the fourth section **60** tends to arch or bend like a bow as it transverses from the first section **30**, along the third section **40**, to the second section **35**. This preferred substantially arcuate shape allows the stretchable material **10** to be positioned in various areas of the garment **5** where the garment may be stressed during the wearer's movements, while providing efficient manufacturing, assembly, and handling of the garment. The aforementioned alternative embodiments may include multiple discrete stretchable sections **10**, although fabrication of such embodiments would likely be somewhat more complex than the illustrated preferred embodiments.

As indicated above, movement by the wearer may cause stress to the garment **5** (including its seams). Typically, for board shorts such as shown in the preferred embodiment, body movements such as bending or twisting at the waist, or flexion of the leg or knee exemplify the type of movements that stress garment material. The preferred positioning of the stretchable material **10** in the top area **45** in the back portion **20** of the third section **35** helps address or relieve some of these stresses, although the stretchable section/material could be placed in a wide variety of other locations and still provide benefits to the wearer.

As illustrated in FIG. 1A, as the wearer begins to move their lower trunk/torso (such as by bending forward, twisting along the waist, or flexing the hip and/or knee area), the garment **5** has a tendency to cling to the certain contact points on the wearer's body due to frictional forces or otherwise, or is simply forced to flex by the overall movement of the wearer's body. In any case, such movement can cause garment seam stress and restrict movement. These problems/risks are increased by continued or repetitive movements in a relatively short period of time, such as is typically performed in sporting activities.

These detriments may occur (or may be even further increased) in some garments **5** only during their intended use. For example, swim trunks or board shorts typically used by surfers, skim boarders, or other water activity participants may hang loose on the wearer when dry, but may become

heavy and cling or drape on the wearer when saturated with water or sand. Bending or twisting movements, and leg positioning including flexion and extension in the water-laden swim or board short becomes more difficult as the garment material adheres to the body, stressing the garment's seams and also makes movement less comfortable.

Areas of the garment **5** typically subject to relatively high stress due to body movements include the top area **45** of the garment **5** formed by the back portion **20** of the third section **35** where bending or twisting movements of the waist tend to cause problems associated with the garment **5** (short or pants). In addition, leg, hip, and/or knee flexion will typically cause garment material stress along the first section **30** and the second section **35** where the aforementioned sections contact the thigh, hip and/or knee regions of the wearer.

Positioning of a fourth section **60**, constructed of stretchable material **10**, at least in this top area **45** of the back portion **20** of the third section **35** where body movement may cause stress to the garment material, facilitates ease of garment material expandability, thereby providing for improved garment wearability by increasing wearer comfort and garment life. For example, continuing with the swim trunk or board short scenario mentioned above, although the swim trunk may be securely attached about the wearer's waist and adhere to the wearer's buttocks or legs when laden with moisture, as the wearer bends at the waist the invention's stretchable material **10** (located between the relatively less stretchable garment material) preferably flexes (expands and/or contracts) with movement of the wearer's body. This flexing/expanding/contracting allows the other garment material to remain generally positioned in its normal location on the wearer's body, or at least to reduce the amount of force/stress and/or degree of sliding movement of the garment over the wearer's skin. Thus, the stretchable material **10** decreases garment stress and increases wearer comfort and mobility.

Depending on the materials selected, the size of the wearer, and other factors, the precise dimensions of the various garment sections (including stretchable section **60**) can vary greatly. In one embodiment, the fourth section **60** of relatively more stretchable material **10** along the top area **45** can be approximately 2.5 inches wide. This amount of stretchable material **10** width has been found to provide enough expandable material to allow the wearer to bend, twist, or otherwise move about the waist without the garment **5** unduly binding to the wearer and/or stressing the garment material. Benefits, as described herein, may also be derived using stretchable material **10** having a width greater than 2.5 inches and less than 2.5 inches, so long as there is sufficient stretchable material **10** to expand and contract with the intended body movement or to provide improved performance of the garment (as compared to garments not having a stretchable fourth section **60**).

The stretchable fourth section **60** can taper or otherwise change width or other characteristics along its length (including alternating between wider and narrower sections repeatedly along the length of that section). As illustrated in FIGS. **1A-E**, for example, the strip **10** tapers from a widest region (at the wearer's lower back) to narrower regions (at the bottom edge of each leg **30** and **35**). A dimension of about 1.5 inches has been found to be suitable in that narrower leg region, although that dimension can be increased or decreased as mentioned herein.

In some instances, for aesthetic reasons, it may be desirable to have as little stretchable material **10** as possible on a particular garment **5** or at a particular location on the garment. Such may be the case with clothing (short or pants) for people who may want to have the freedom of unrestrained movement yet desire to have clothes that are considered by some to be

more fashionable. Thus, the stretchable material **10** may be placed along some or all of the top of the third section **35**, so that the wearer may enjoy the freedom of movement provided by the stretchable material **10** while maintaining a potentially more stylish or alternatively stylish look.

More generally, the precise size, shape, and positioning of the one or more relatively "stretchable or more stretchable" sections **10** can take into account aesthetic considerations. For example, by making the color of the stretchable section **10** different from the adjacent fabric, various visual effects or patterns (or even symbols/messages/etc.) can be created.

Depending on selection of fabrics and the colors thereof, as well as the methods of assembly and other factors, the stretchable section **10** can even be made to "blend in" visually with the remainder of the garment. This provides certain aesthetic effects, and/or makes it less likely that third persons will notice the "stretch panel" within the garment.

As described above, fourth section **60** may extend continuously along a length of each of the first section or leg **30** and the second section or leg **35**. For example (although not illustrated), the fourth section **60** may terminate near the hip area of each of the first section **30** and the second section **35** (thus extending only partially into the garment legs). Alternatively, as shown in FIG. **1E**, the fourth section **60** may extend along an entire length of each of the first section **30** and the second section **35**. In other words, the strip **60** may extend to any suitable length through the garment.

As indicated above, similar to the benefits derived by having the stretchable material **10** positioned along the top area **45** of the back portion **20** of the garment **5**, stretchable material **10** located between garment material along the first section **30** and the second section **35** will expand and/or contract with movement of the body while reducing or eliminating (a) stress on the other garment material and (b) sliding or dragging of garment material on the wearer's leg or hip area.

As illustrated in FIG. **1E**, the fourth section **60** may extend along the entire length of each of the first leg covering and the second leg covering. This stretchable material **10** width (even though tapered to narrower than on the lower back of the garment) preferably provides enough expandable material to allow the wearer to flex, extend, or otherwise move about the hip and leg regions without unduly binding or stressing of the garment material. Benefits, as described herein, may also be derived using stretchable material **10** having other widths so long as there is sufficient stretchable material **10** to provide some desired expand or elastic action with the wearer's body movements.

The benefits of the invention in a garment **5** intended for wear about a person's lower trunk/torso are similar to those for a garment **65** intended for wear about a person's, upper trunk/torso and extremities **70** (such as a shirt, pullover, or similar type apparel). For ease of describing the present invention, it will be understood that the foregoing description of the present invention as applied to a garment **5** such as a short at least generally applies to embodiments such as a shirt **65** (as shown in FIGS. **2A** and **2B**). Similar to a garment **5** such as shorts or pants, as described above, the garment **65** intended for wear about a person's upper trunk/torso **70** includes a first section or arm **75** adapted to receive within and permit to pass therethrough one extremity (an arm) of the person and a second section or arm **80** adapted to receive within and permit to pass therethrough the opposite extremity (arm) of the person. In other words, the first section **75** and second section **80** of the garment **65** will typically be a sleeve or arm covering.

The arm covering permits an arm to be received within and to pass therethrough, as shown in FIG. **2A**. Similar to leg

coverings of a short, the sleeve of the shirt may be of varied lengths. For example, the sleeve may extend to an area of the person's upper arm or extend to the wearer's wrist or beyond. The garment **65** also includes a third section **85** having a back portion connected to a front portion. The front portion (not shown) and back portion **90** are adapted to receive a portion of a person's body; in this case the person's chest and back region. As with the third section **40** of the short, the third section **85** of the shirt joins together the first section **75** and the second section **80** (sleeves) of the garment **65**.

As best shown in FIG. 2A, the garment **65** includes a fourth section **95** constructed of a stretchable material **10** located between other garment material. The fourth section **95** preferably has a substantially arcuate shape, and is positioned along a top area, as shown generally by arrows "b" in FIG. 2B, of the garment **65** formed by the back portion **90** of the third section **85**. Similar to a short or pants embodiment, the top area of the third section **85** of the shirt may be considered to extend from a top edge **100** of the garment **65** to approximately six inches below the top edge **100** (although other dimensions may apply and be used).

The fourth section **95** extends continuously along a length of each of the first section **75** and the second section **80**. The substantially arcuate shape of the fourth section **95** allows the stretchable material **10** to be positioned along areas of the garment **65** (such as the person's back, shoulder region, upper arms, and/or elbow/forearm) where the garment material may be stressed due to the wearer's body movements.

The top area formed by the back portion **90** of the third section **85** is one such area where body movement of the shoulders or upper back of the wearer may cause stress to the garment material including seams. Typically, extending or reaching with the arms, and hunching or rolling the back exemplify the types of movement that stresses shirts or similar garments as the garment material is stretched or caused to expand against the frictional force between garment material and the person's skin. These types of movements are particularly detrimental when a bottom edge **105** of the third section **85** is tucked-in or secured by the wearer's short or pants, thus restricting garment material movement.

Stretchable fabric such as spandex, LYCRA®, neoprene or the aforementioned neoprene material known as "ultra-flex", or a similar type material positioned in these stressed regions along the first **75**, second **80**, and third **85** sections of the garment **65**, provide the benefit of relieving seam stress by allowing the material to expand or "give" with body movement resulting in increased garment "life". Thus, the stretchable material **10** appropriately positioned on the garment **65** provides improved wearer comfort and garment durability, i.e., wearability.

In embodiments such as that illustrated in FIGS. 1A-E, the present invention may be considered an improved garment **5** intended for wear about a person's lower trunk. The garment **5** preferably includes "garment material" (typically relatively non-elastic, as discussed herein) forming a back portion **20**, a front portion **25**, a first leg covering **30**, and a second leg covering **35**. The garment **5** preferably also includes a relatively stretchable material **10** forming part of the garment so that stresses on the garment can be at least partially absorbed by elastic deformation of the stretchable material **10**.

Similarly, in embodiments such as illustrated in FIGS. 2A-B, the present invention may be considered an improved shirt **65** for wear by a person. The shirt **65** preferably has garment material forming a front section, a back portion **90**, a first arm covering **70**, and a second arm covering **75**, with stretchable material **10** located between garment material.

Thus, in the illustrated embodiments of FIGS. 1A-E and 2A-B, the elongated strips of relatively stretchable material extend continuously from an edge of the first limb section remote from said torso section, across said first limb section and said torso section and said second limb section, to an edge of the second limb section remote from said torso section. Among other things, this edge-to-edge reach of the stretchable material allows not only for the stretching discussed herein, but also can reduce "twisting" type distortion of the garment (that would otherwise occur during extreme motions of the wearer's body). In that regard, the edge-to-edge arrangement effectively bisects the less-stretchable portion of the garment, and permits some degree of "longitudinal shifting" of the garment's relatively less-stretchable portion. In other words, for embodiments having the aforementioned edge-to-edge configuration of stretchable material **10**, the stretch of the material is not limited to expansion that is transverse to the lengthwise "axis" of the elongated strip. In addition to that expansion (which can be thought of as expansion generally perpendicular to the lengthwise axis of the strip), the strip permits the garment to "slip" or "shift" along a plane somewhat parallel to the strip's lengthwise axis. Such "parallel slip" or shifting can reduce or eliminate wrinkling or binding that might otherwise occur in that region of the garment.

The invention further includes a wide variety of methods associated with the garment described herein. Among others, such methods include those of constructing a garment, including the steps of (1) providing a main garment portion fabricated from relatively less-stretchable or non-stretchable material, with the main garment portion sized and configured to fit loosely on the wearer; (2) providing a second garment portion, the second portion fabricated from relatively stretchable material, the second portion sized and configured to fit loosely on the wearer and be stretched only when the wearer flexes his or her body from its normal relaxed position; (3) assembling the second garment portion between sections of the main garment portion, the assembled main and second garment portion each covering separate areas of the wearer's body and collectively covering a desired area of the wearer's body.

Further method steps include, by way of example and not by way of limitation, providing the second garment portion in the form of an elongated strip having first and second longitudinal edges generally parallel to a longitudinal axis of the strip, the strip also having first and second ends at the extremities of the longitudinal axis of the strip, positioning the first end to form a portion of an edge of the garment, attaching the first and second longitudinal edges to corresponding edges of the main garment portion, and positioning the second end of the strip to form another portion of an edge of the garment.

While certain embodiments are illustrated in the drawings and are described herein, including preferred embodiments, it will be apparent to those skilled in the art that the specific embodiments described herein may be modified without departing from the inventive concepts described. For example, while certain features of the present invention are illustrated as physically being in a particular location, having a specified dimensions, or applied to a definite garment, persons of ordinary skill in the art will understand that other location, dimensions, and garments can be used without departing from the inventive concept.

What is claimed is:

1. Board shorts for use during surfing or similar activities, including:
  - a first portion fabricated from a less stretchable material, said first portion comprising the majority of said shorts,

## 13

and a second portion fabricated from a more stretchable material, said second portion configured and positioned in said shorts to provide elastic stretching of said second portion during movement of the wearer's body;  
 said second portion extending in an arcuate path from the front of one thigh of a first leg of said shorts, upward along the first leg, around the side of the shorts to the back of the shorts, across the back of the shorts, around the other side of the shorts, downward along the second leg to the front of the second thigh of said shorts;  
 said first portion comprising an upper ring configured to encircle the wearer's torso, said first portion extending continuously from a front section of said upper ring downwardly through a crotch portion and then upwardly to operatively join a lower edge of said second portion, said second portion comprising an elongated strip that is operatively abutted along both a first edge and a second edge by first portion.

2. The shorts of claim 1, in which said second portion extends from a lower edge of a first leg of said shorts across the buttocks area of the shorts, and down to a lower edge of a second leg of shorts.

3. The shorts of claim 2, in which said second portion extends across the buttocks along a generally upper area of the shorts and is sized and positioned to return to a relatively unstretched condition after said movement of the wearer's body.

4. The short of claim 1, in which said second portion is positioned as an elongated strip of material connected at most of its edges to said first portion of material.

5. The short of claim 1, in which said second portion is fabricated from elastomeric foam.

6. The short of claim 1, in which said second portion is fabricated from 4-way stretch neoprene.

7. The shorts of claim 1, in which second portion is a solid piece of material without any internal seams.

8. Board shorts for water related activities, the shorts, comprising:

a first limb section configured to receive within and permit to pass therethrough one limb of the person;

## 14

a second limb section configured to receive within and permit to pass therethrough second limb of the person;  
 a torso section joining the first limb section and the second limb section, the torso section having a back portion and a front portion, said back portion and said front portion configured to receive a corresponding portion of a person's torso; and

an elongated strip of material more stretchable than adjacent materials in said first and second limb sections and said torso section, said elongated strip extending in an arched manner across all of the back portion of the torso section said strip having opposite ends extending respectively diagonally down around opposite sides of the torso section and extending further downwardly and around to a front inside portion of said first limb section and said second limb section, said strip positioned and configured so that rotations of said limbs with respect to the wearer's torso cause the elongated strip to stretch;

said torso portion extending around the wearer's waist and downwardly from an uppermost front edge of the shorts continuing downwardly through a crotch portion, and up into the area of the buttocks and adjacent a lower edge of said elongated strip, said elongated strip thereby defining a continuous stretch plane within the shorts, said plane running across the wearer's buttocks and around the wearer's hips and downwardly across the front of the wearer's thighs,

wherein said elongated strip of material extends along an entire length of each said first limb and said second limb sections and said torso section and attaches to an inside front edge of said first limb section and said second limb section.

9. The shorts of claim 8, wherein the said stretchable material is elastomeric foam.

10. The shorts of claim 8, in which said garment is sized and configured to fit loosely rather than snugly against the wearer's body when the wearer is in a normal standing position.

\* \* \* \* \*