

US007928654B2

(12) **United States Patent**
Tsuchiya et al.

(10) **Patent No.:** **US 7,928,654 B2**
(45) **Date of Patent:** **Apr. 19, 2011**

(54) **DISPLAY DEVICE AND METHOD FOR MANUFACTURING THE SAME**

(75) Inventors: **Kaoru Tsuchiya**, Kanagawa (JP); **Aya Anzai**, Kanagawa (JP); **Masayuki Sakakura**, Kanagawa (JP); **Masaharu Nagai**, Kanagawa (JP); **Yutaka Matsuda**, Tochigi (JP)

(73) Assignee: **Semiconductor Energy laboratory Co., Ltd.** (JP)

(*) Notice: Subject to any disclaimer, the term of this patent is extended or adjusted under 35 U.S.C. 154(b) by 422 days.

(21) Appl. No.: **10/919,605**

(22) Filed: **Aug. 17, 2004**

(65) **Prior Publication Data**

US 2005/0046346 A1 Mar. 3, 2005

(30) **Foreign Application Priority Data**

Aug. 29, 2003 (JP) 2003-347601
Sep. 12, 2003 (JP) 2003-322334

(51) **Int. Cl.**

H01J 1/62 (2006.01)
H01J 63/04 (2006.01)

(52) **U.S. Cl.** **313/512**; 313/483; 313/498; 313/500; 313/503; 313/504; 313/505; 313/506; 313/509

(58) **Field of Classification Search** None
See application file for complete search history.

(56) **References Cited**

U.S. PATENT DOCUMENTS

5,882,761 A 3/1999 Kawami et al. 428/69
6,633,121 B2 10/2003 Eida et al.

6,798,132 B2 9/2004 Satake
6,822,264 B2 11/2004 Yamazaki et al.
6,833,560 B2* 12/2004 Konuma et al. 257/72
6,861,710 B2 3/2005 Murakami et al.
6,864,508 B2 3/2005 Yamazaki et al.
7,033,848 B2 4/2006 Murakami et al.
7,112,115 B1 9/2006 Yamazaki et al. 445/25
7,129,523 B2 10/2006 Yamazaki et al.
7,288,420 B1 10/2007 Yamazaki et al.
7,393,707 B2 7/2008 Yamazaki et al.
7,405,515 B2 7/2008 Satake
7,462,501 B2 12/2008 Yamazaki et al.
7,486,368 B2* 2/2009 Sakakura et al. 349/153

(Continued)

FOREIGN PATENT DOCUMENTS

CN 1383352 A 12/2002

(Continued)

OTHER PUBLICATIONS

Miyashita et al , "Full Color Displays Fabricated By Ink-Jet Printing", Asia Display / IDW '01 (2001), pp. 1399-1402.

(Continued)

Primary Examiner — Nimeshkumar D Patel

Assistant Examiner — Natalie K Walford

(74) *Attorney, Agent, or Firm* — Husch Blackwell LLP

(57) **ABSTRACT**

An object of the present invention is to provide such a sealing structure that a material to be a deterioration factor such as water or oxygen is prevented from entering from external and sufficient reliability is obtained in a display using an organic or inorganic electroluminescent element. In view of the above object, focusing on permeability of an interlayer insulating film, deterioration of an electroluminescent element is suppressed and sufficient reliability is obtained by preventing water entry from an interlayer insulating film according to the present invention.

21 Claims, 22 Drawing Sheets

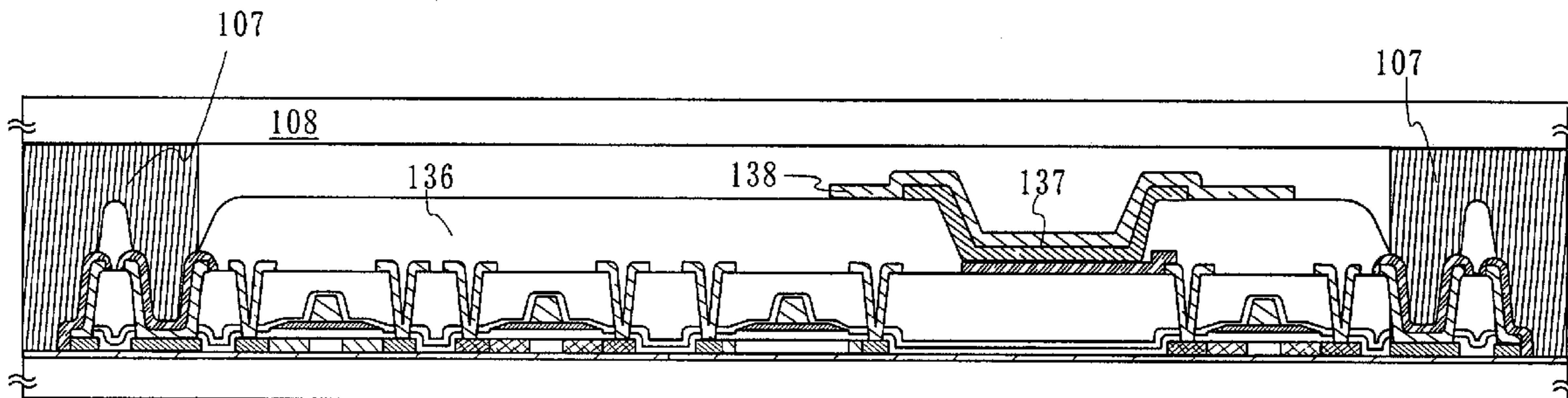

US 7,928,654 B2

Page 2

U.S. PATENT DOCUMENTS

7,492,012 B2 2/2009 Murakami et al.
7,619,258 B2* 11/2009 Tsuchiya et al. 257/83
7,629,617 B2 12/2009 Yamazaki et al.
2001/0017684 A1 8/2001 Hirakata et al. 349/153
2002/0011975 A1 1/2002 Yamazaki et al. 345/76
2002/0022591 A1 2/2002 Algate et al. 438/30
2002/0113248 A1 8/2002 Yamagata et al.
2002/0158568 A1* 10/2002 Satake 313/493
2003/0089991 A1 5/2003 Yamazaki et al.
2003/0094615 A1* 5/2003 Yamazaki et al. 257/72
2003/0127651 A1 7/2003 Murakami et al.
2003/0227255 A1* 12/2003 Auch et al. 313/506
2004/0185301 A1 9/2004 Tsuchiya et al. 428/690
2004/0232418 A1 11/2004 Koyama et al.
2004/0263740 A1 12/2004 Sakakura et al. 349/138
2005/0045891 A1 3/2005 Yamazaki et al. 257/72
2005/0156519 A1 7/2005 Yoshizawa et al. 313/512
2005/0206313 A1 9/2005 Yamazaki et al.
2005/0218396 A1 10/2005 Tsuchiya et al. 257/13
2006/0006424 A1 1/2006 Yamazaki et al.
2006/0151789 A1 7/2006 Murakami et al.
2009/0026946 A1 1/2009 Satake
2009/0256467 A1 10/2009 Yamazaki et al.

FOREIGN PATENT DOCUMENTS

EP 0 776 147 A1 5/1997
EP 0 993 235 4/2000
EP 1 058 314 A2 12/2000
EP 1 176 850 A1 1/2002
EP 1 253 643 A2 10/2002
EP 1 870 948 A2 12/2007
JP 09-148066 6/1997
JP 10-335060 12/1998
JP 11 271753 10/1999
JP 2001-203076 7/2001
JP 2001-357973 12/2001
JP 2003-197367 7/2003
JP 2003-229250 8/2003
JP 2003-297552 10/2003
WO WO 01/58221 A1 8/2001

OTHER PUBLICATIONS

European Search Report re application No. EP 04019744.4, dated Nov. 16, 2009.

Office Action re Chinese application No. CN 20081018633.7, dated Mar. 2, 2010 (with English translation).

* cited by examiner

Fig. 1A

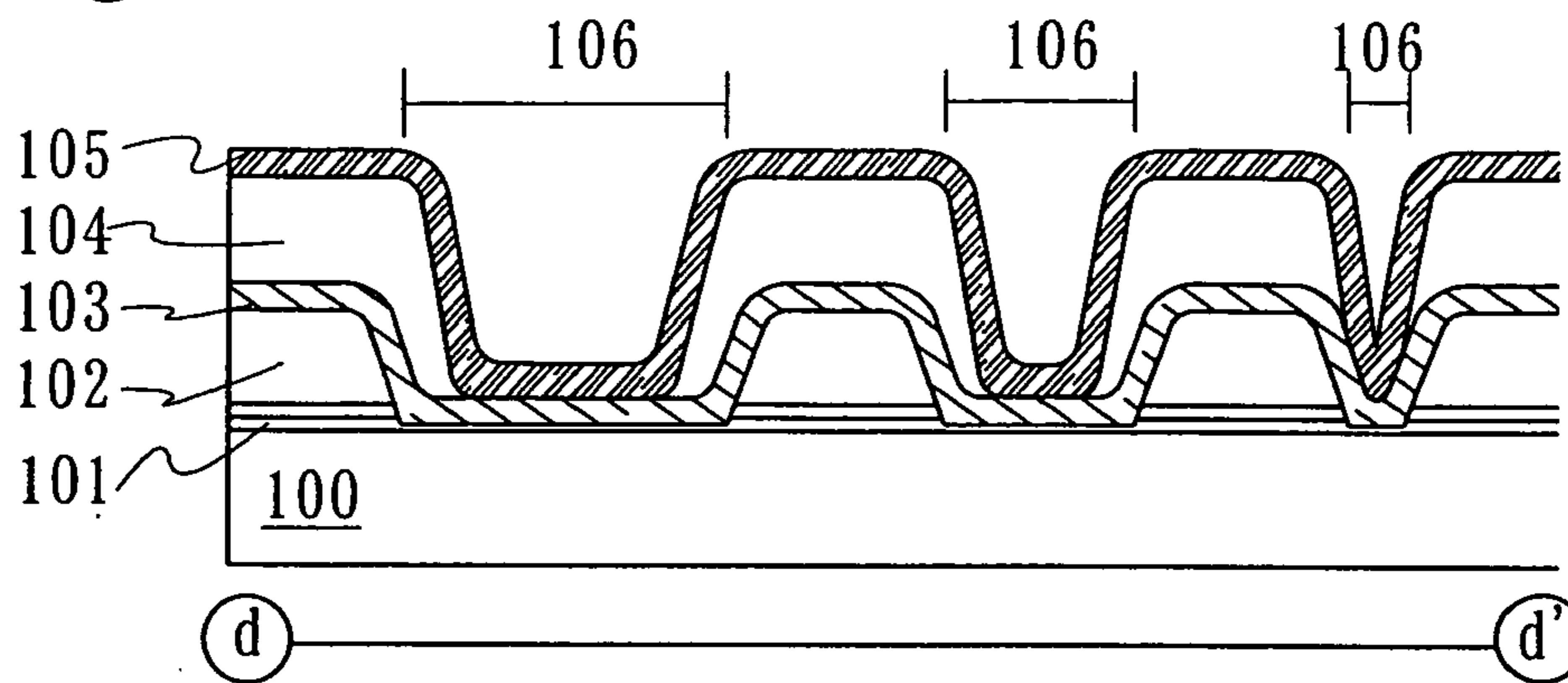

Fig. 1B

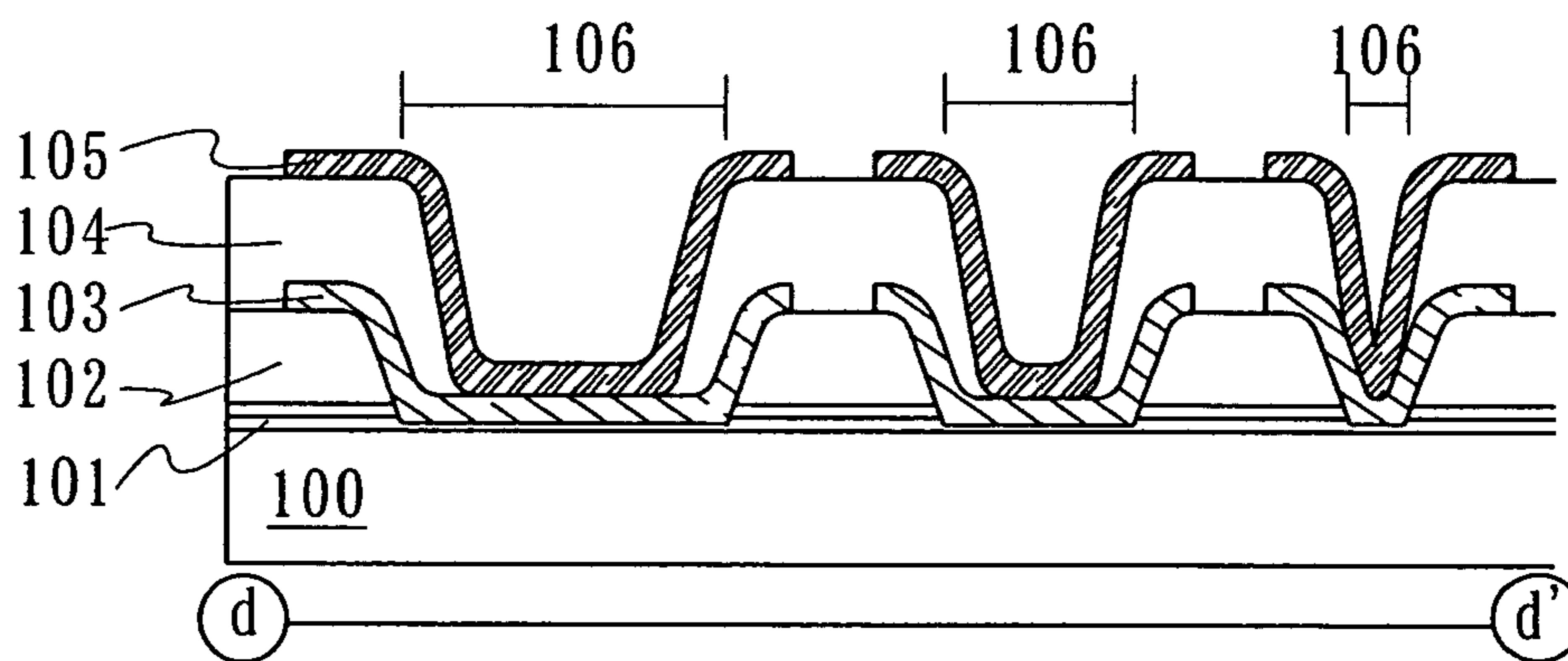
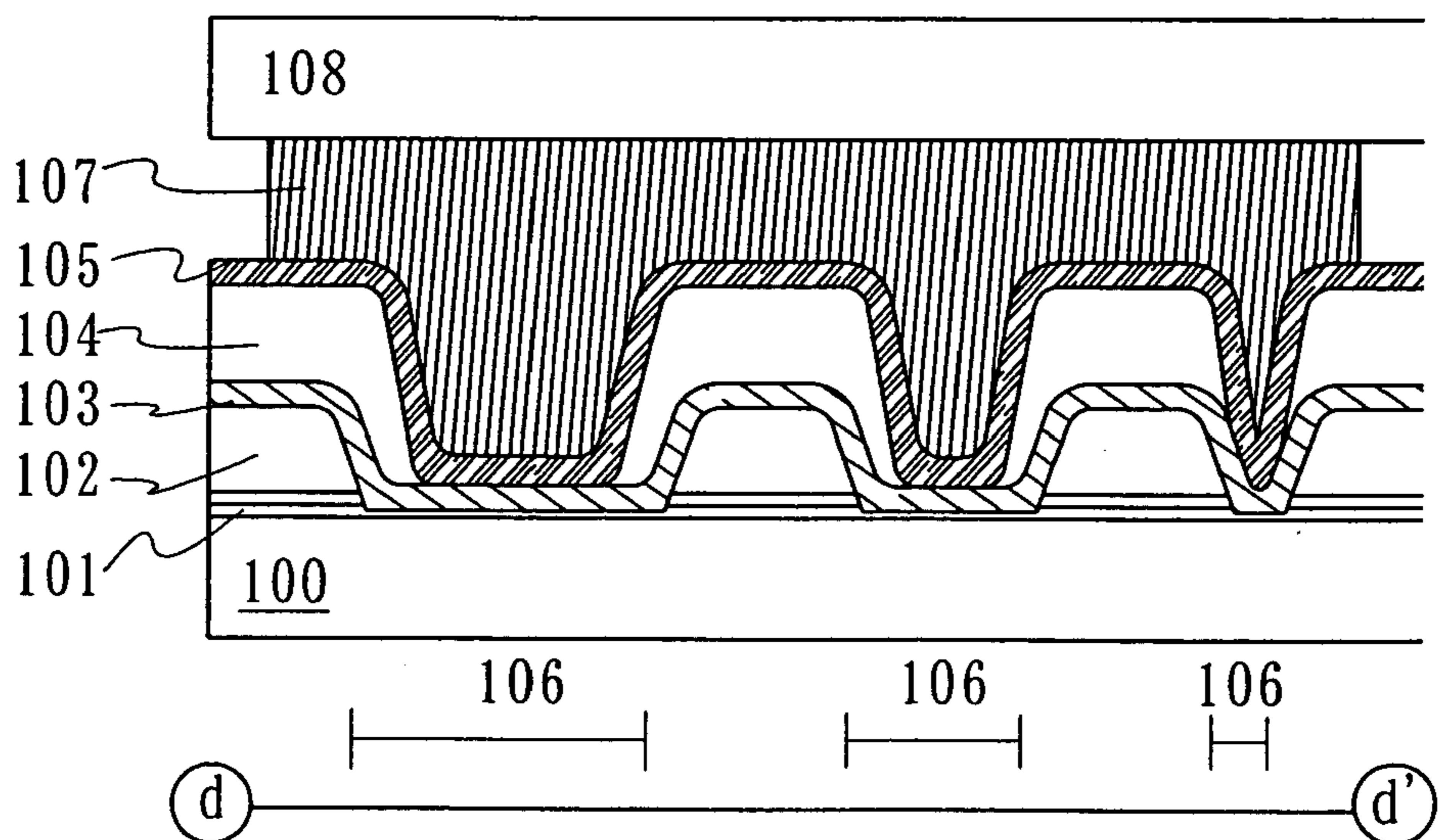

Fig. 1C



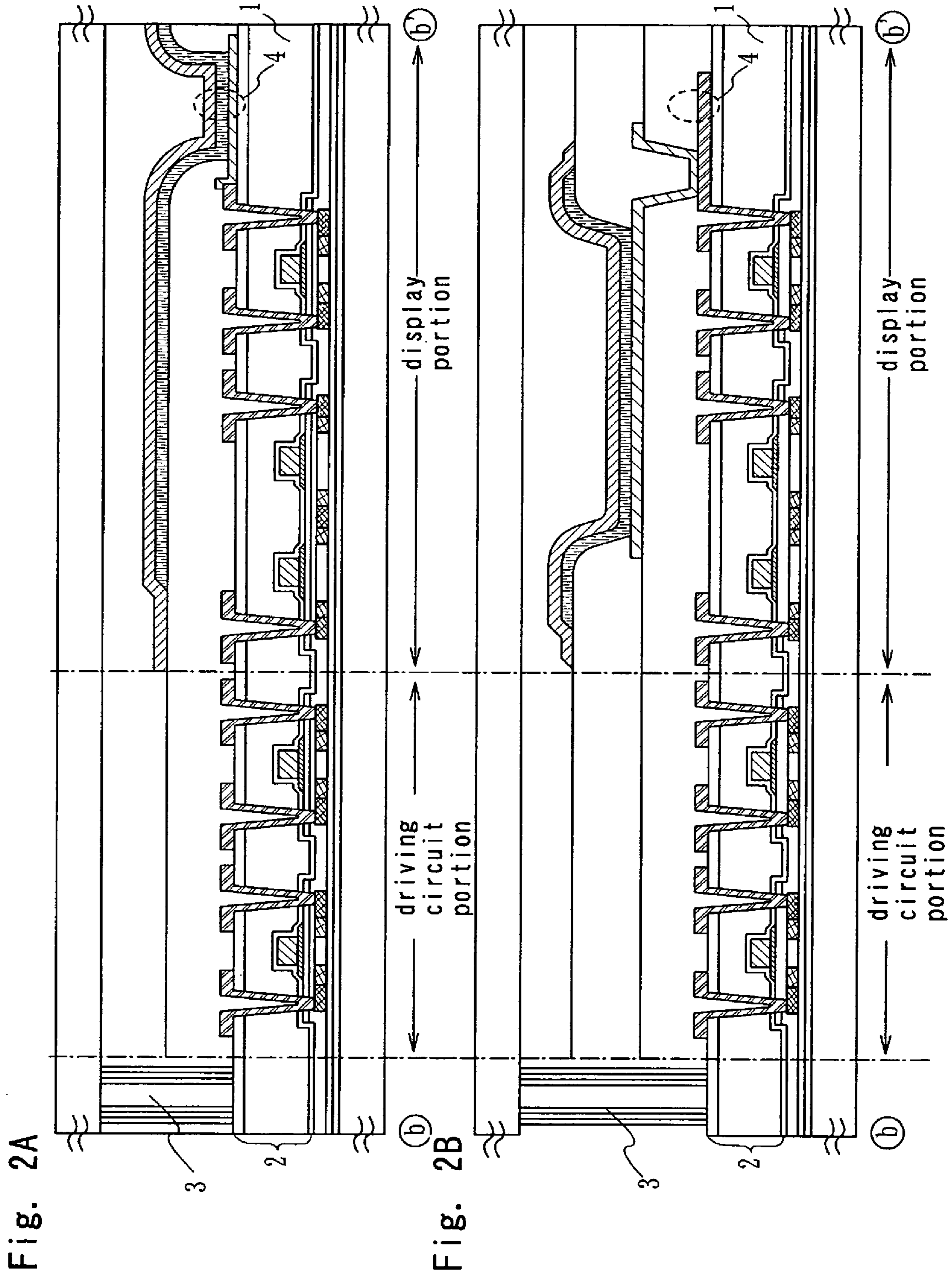

Fig. 2A

Fig. 2B

Fig. 3

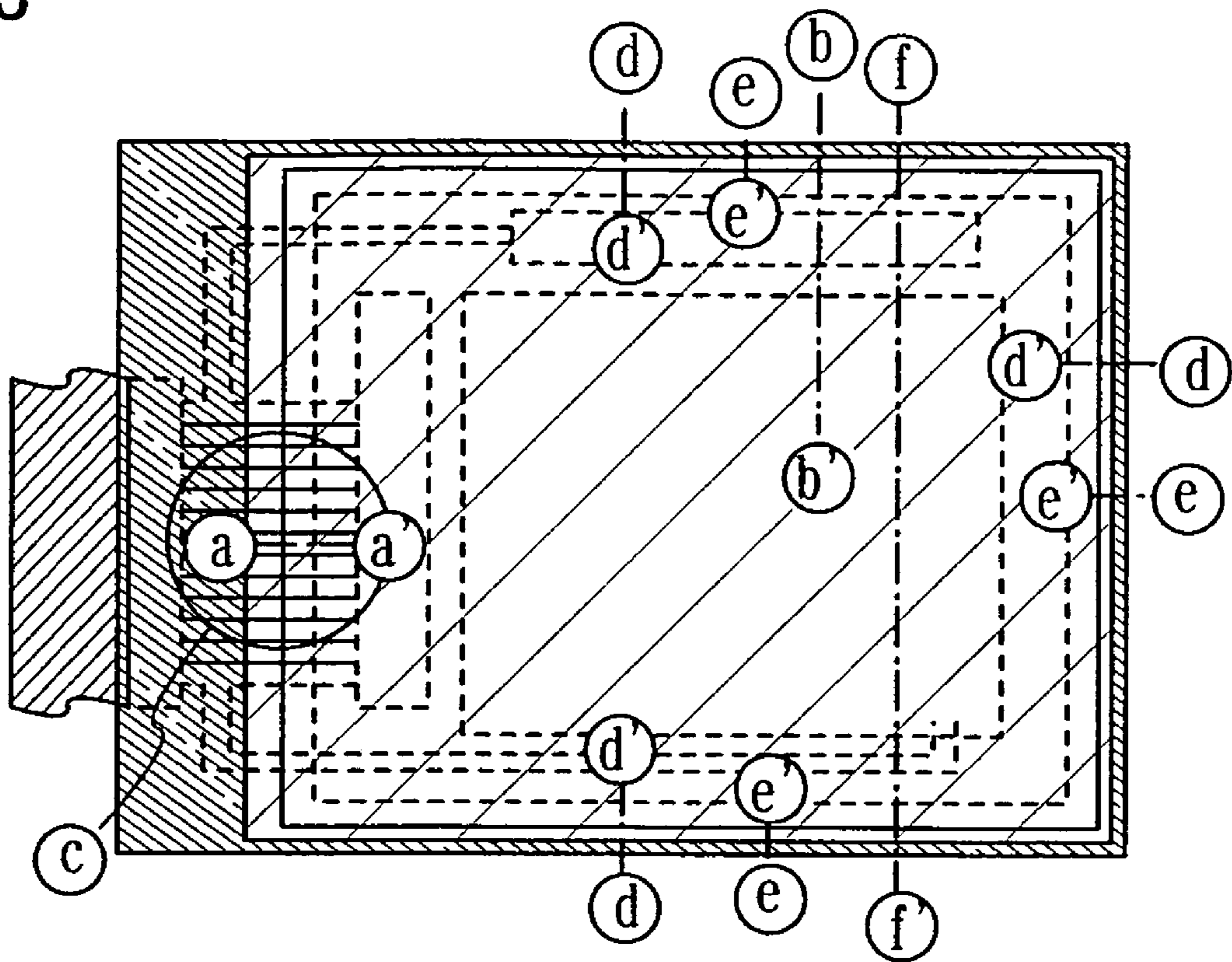

Fig. 4A

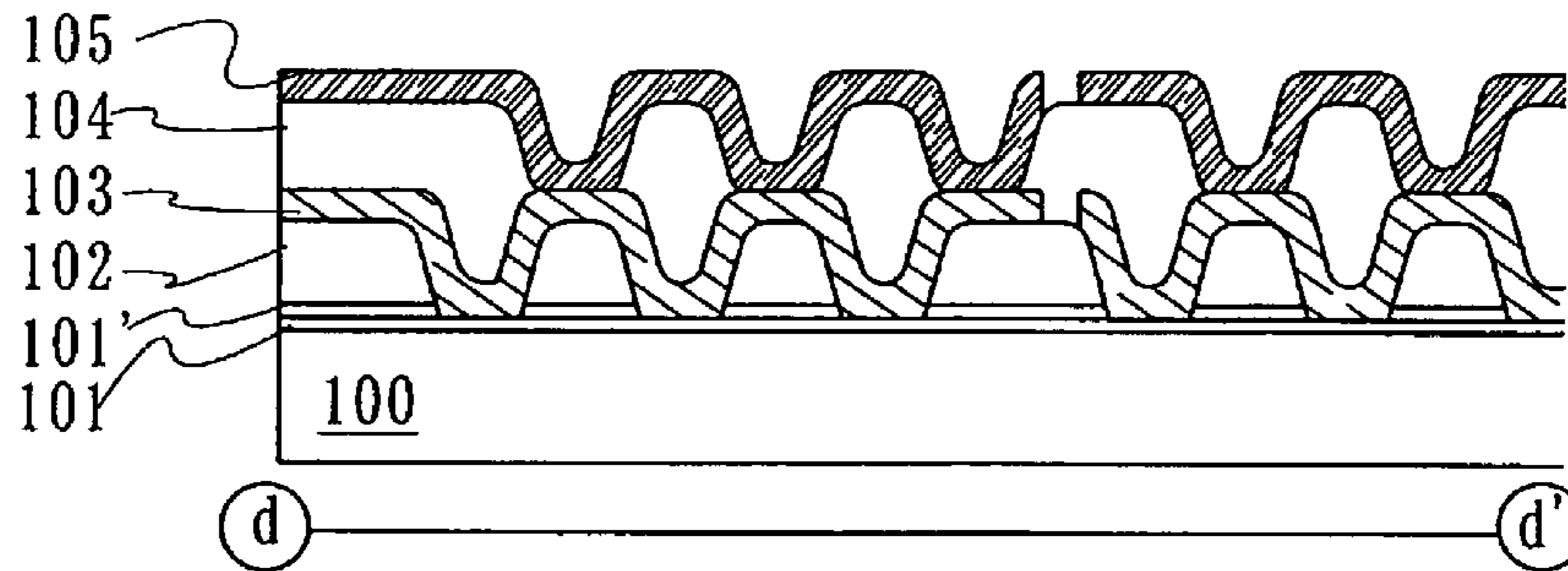

Fig. 4B

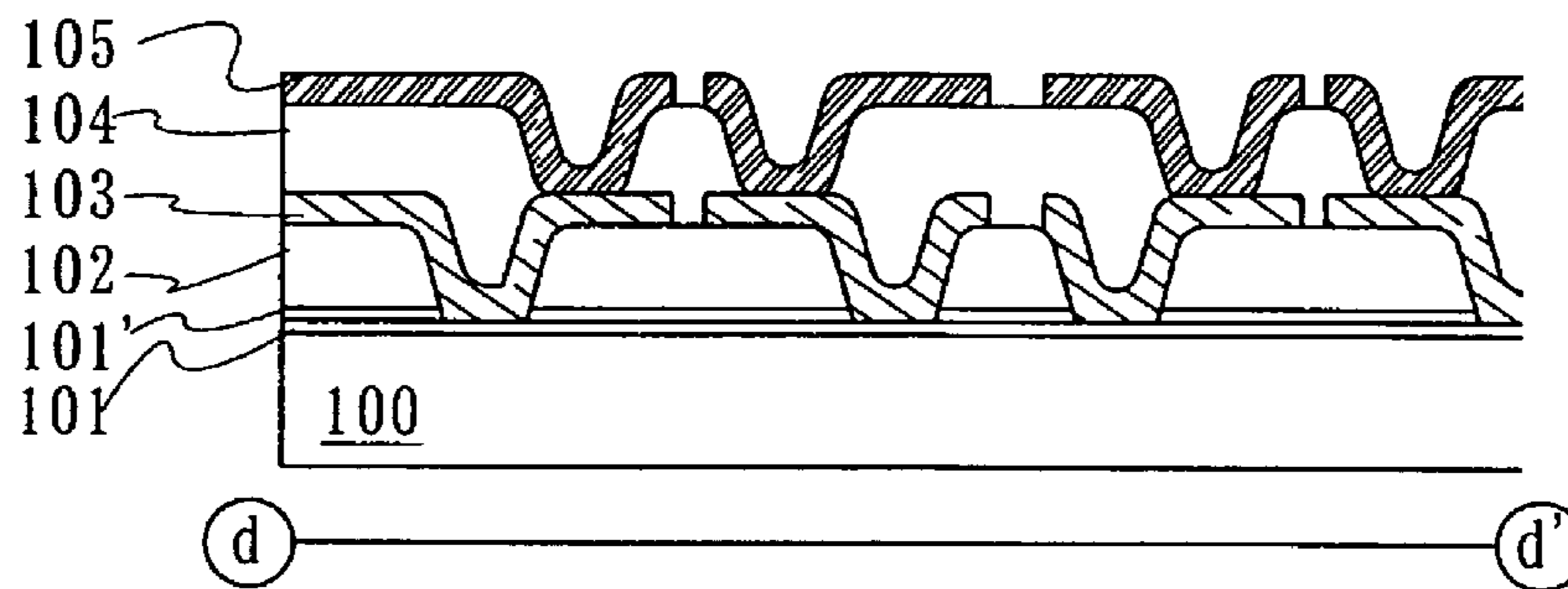

Fig. 5A

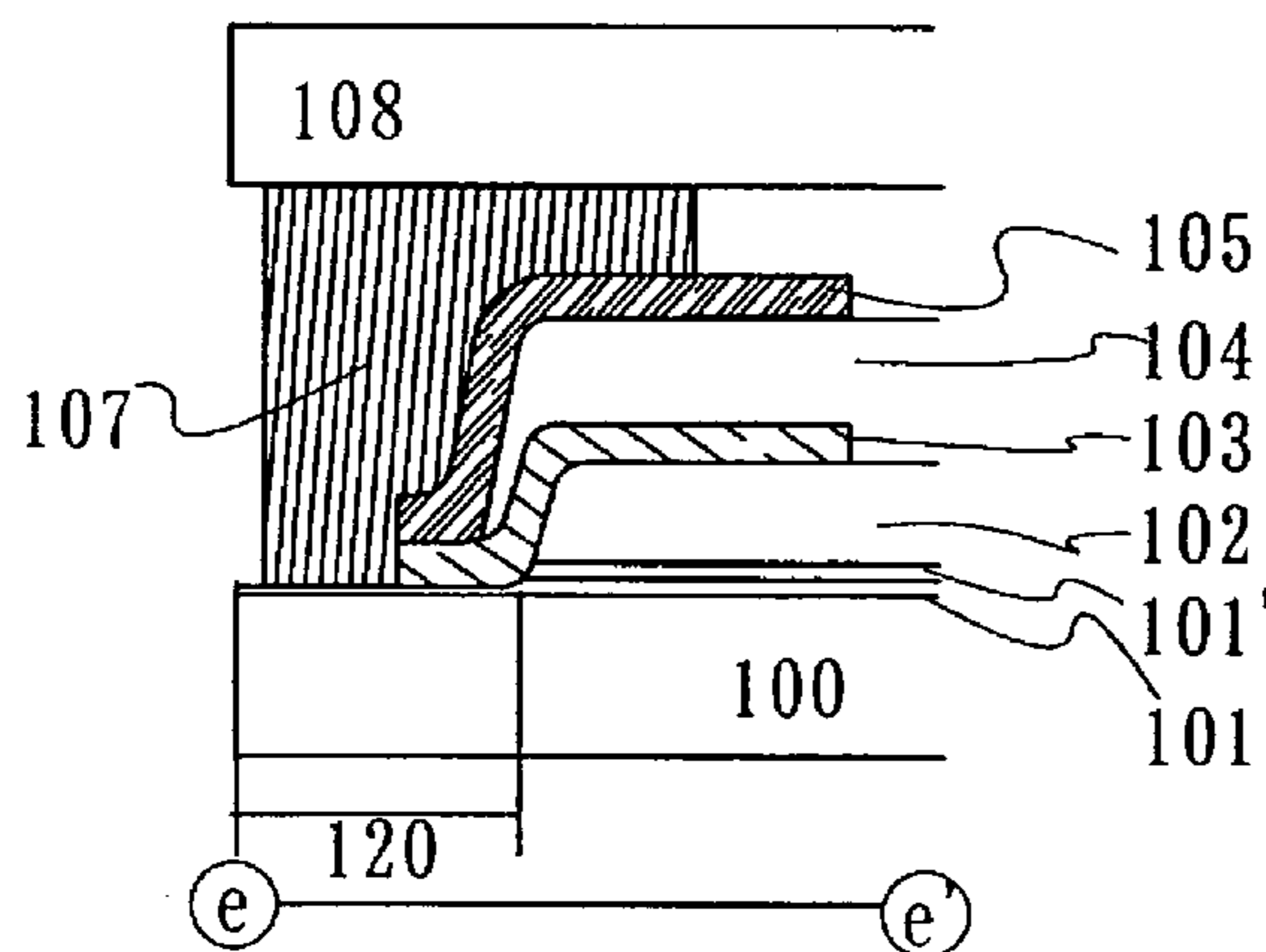
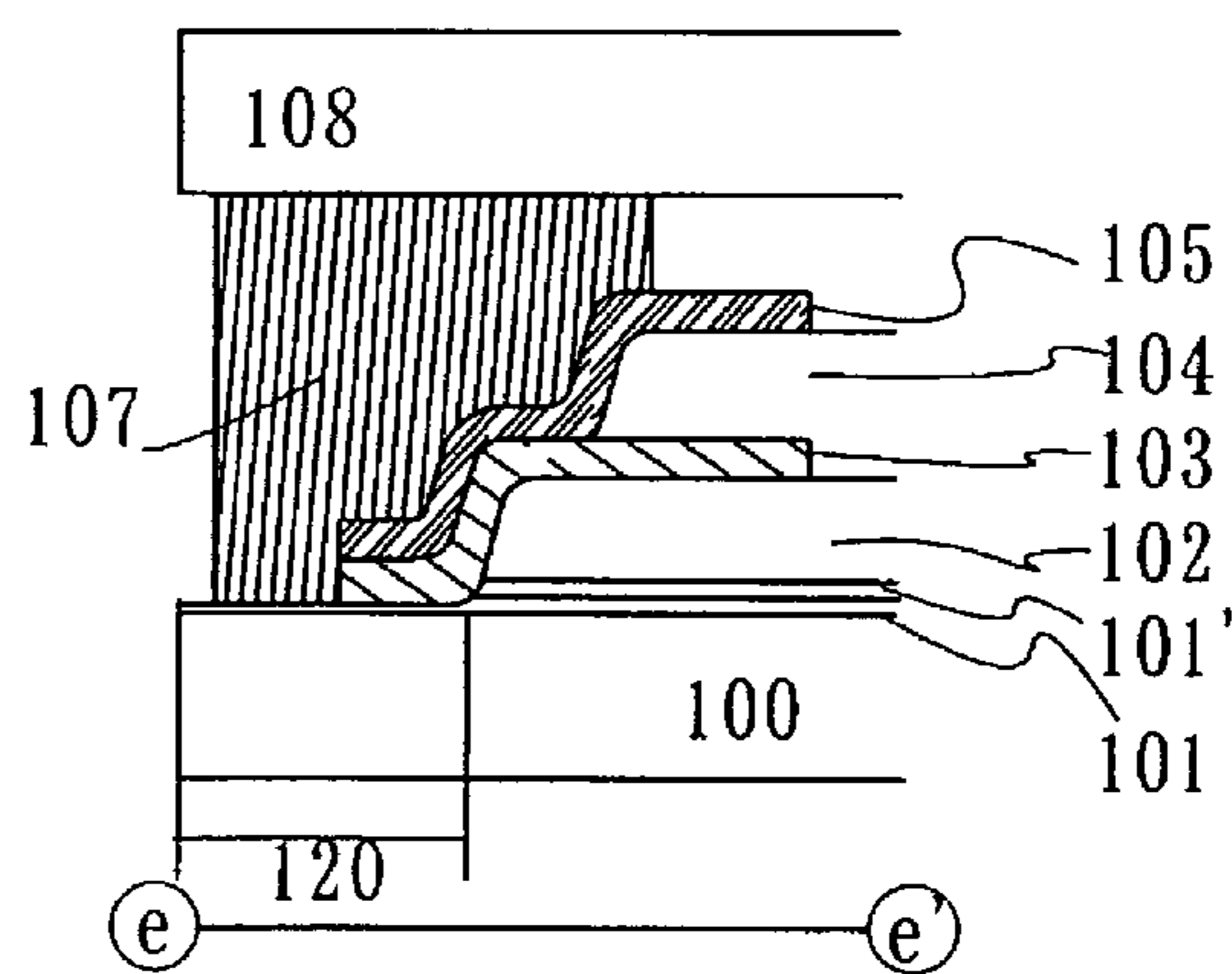

Fig. 5B



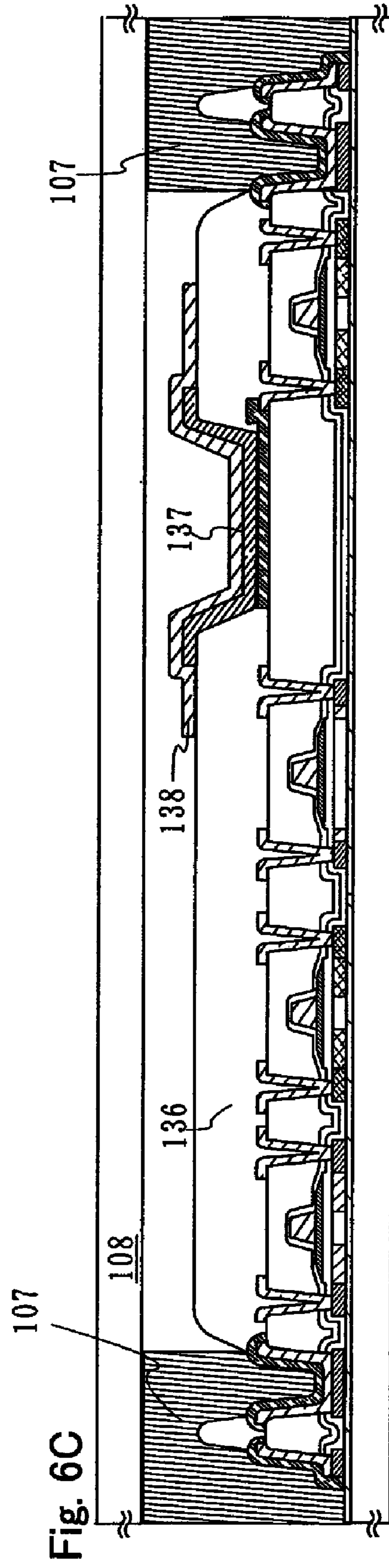
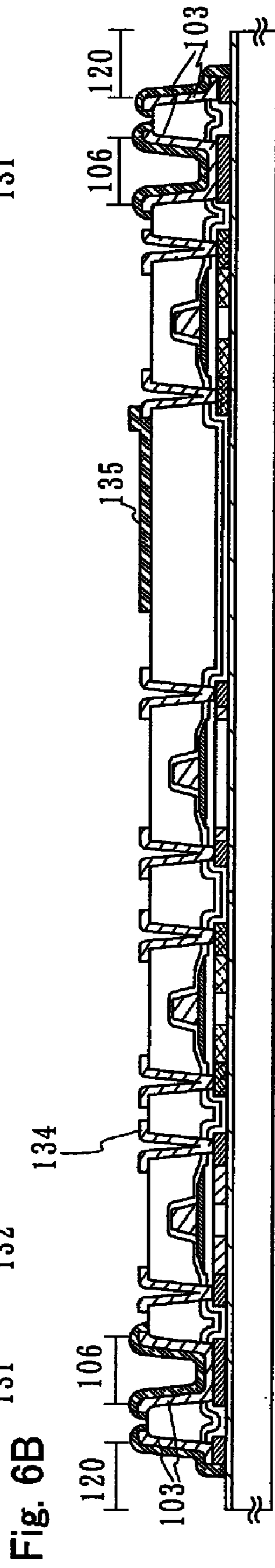
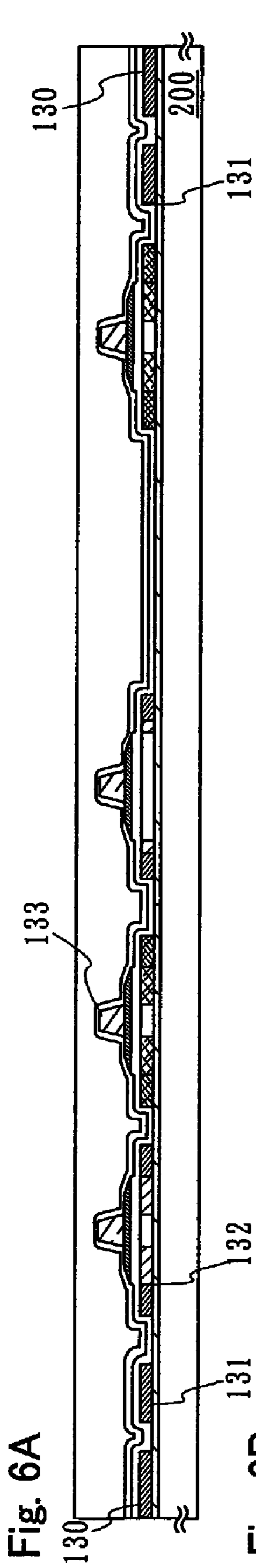

Fig. 7A

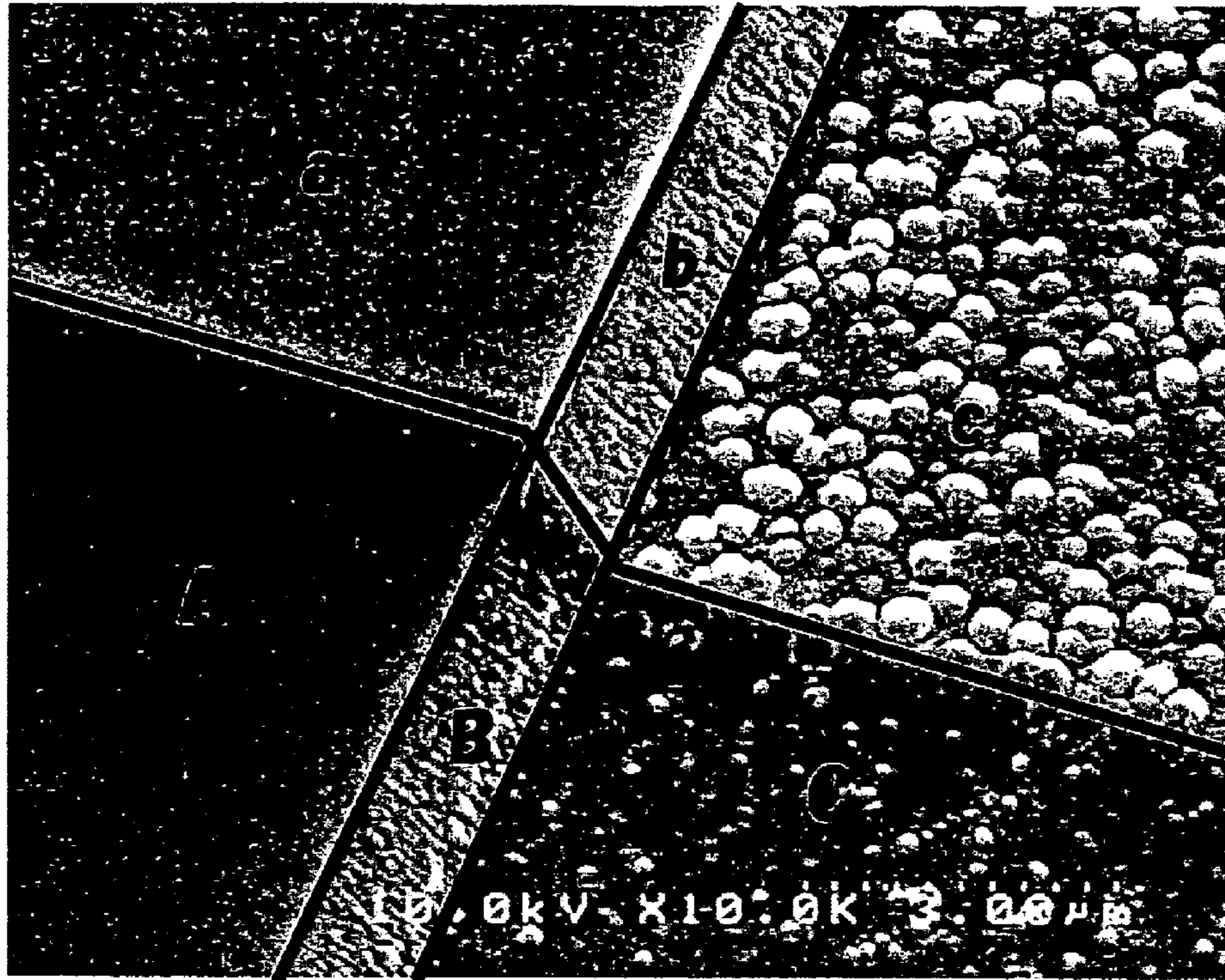

Fig. 7B

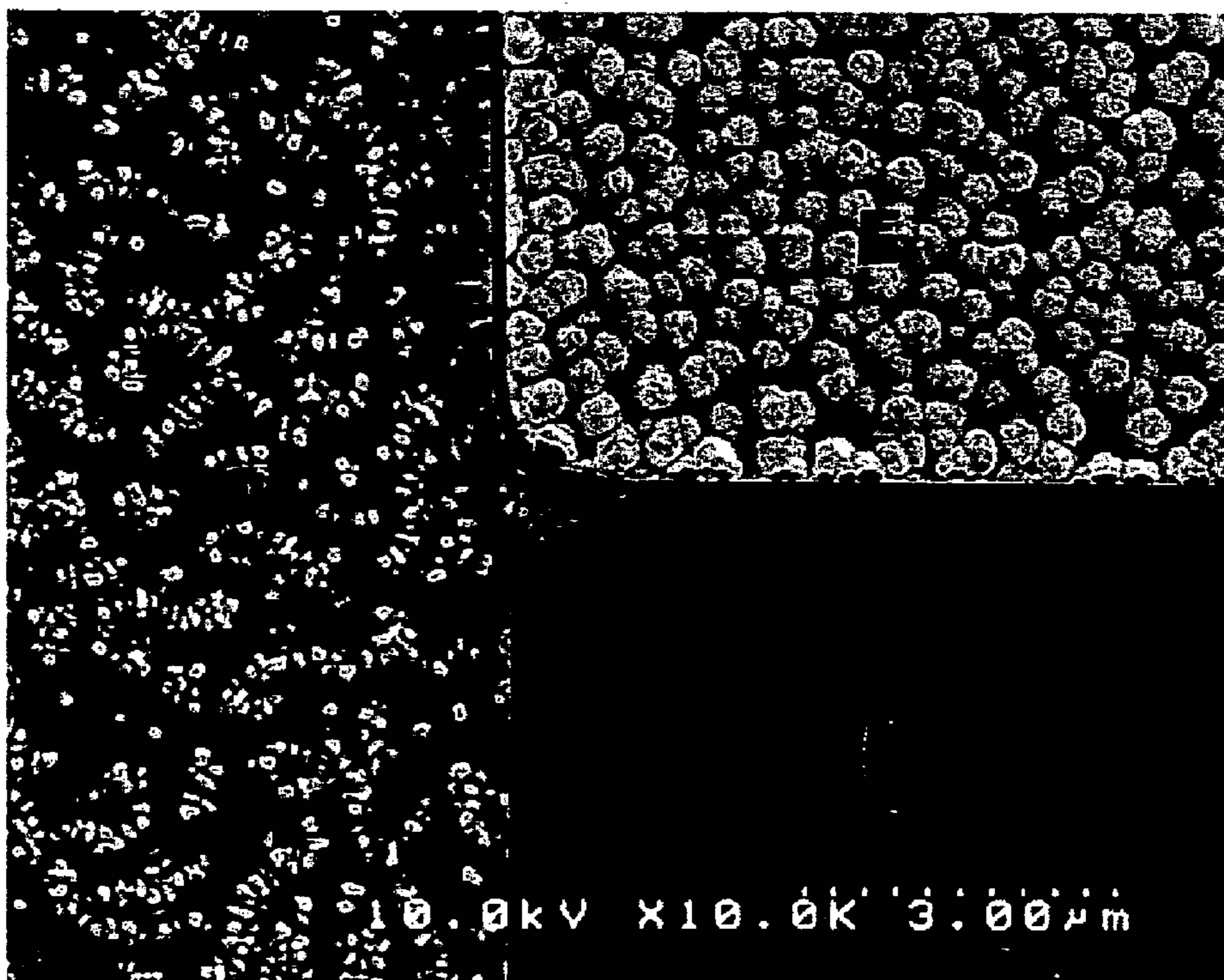

Fig. 8A

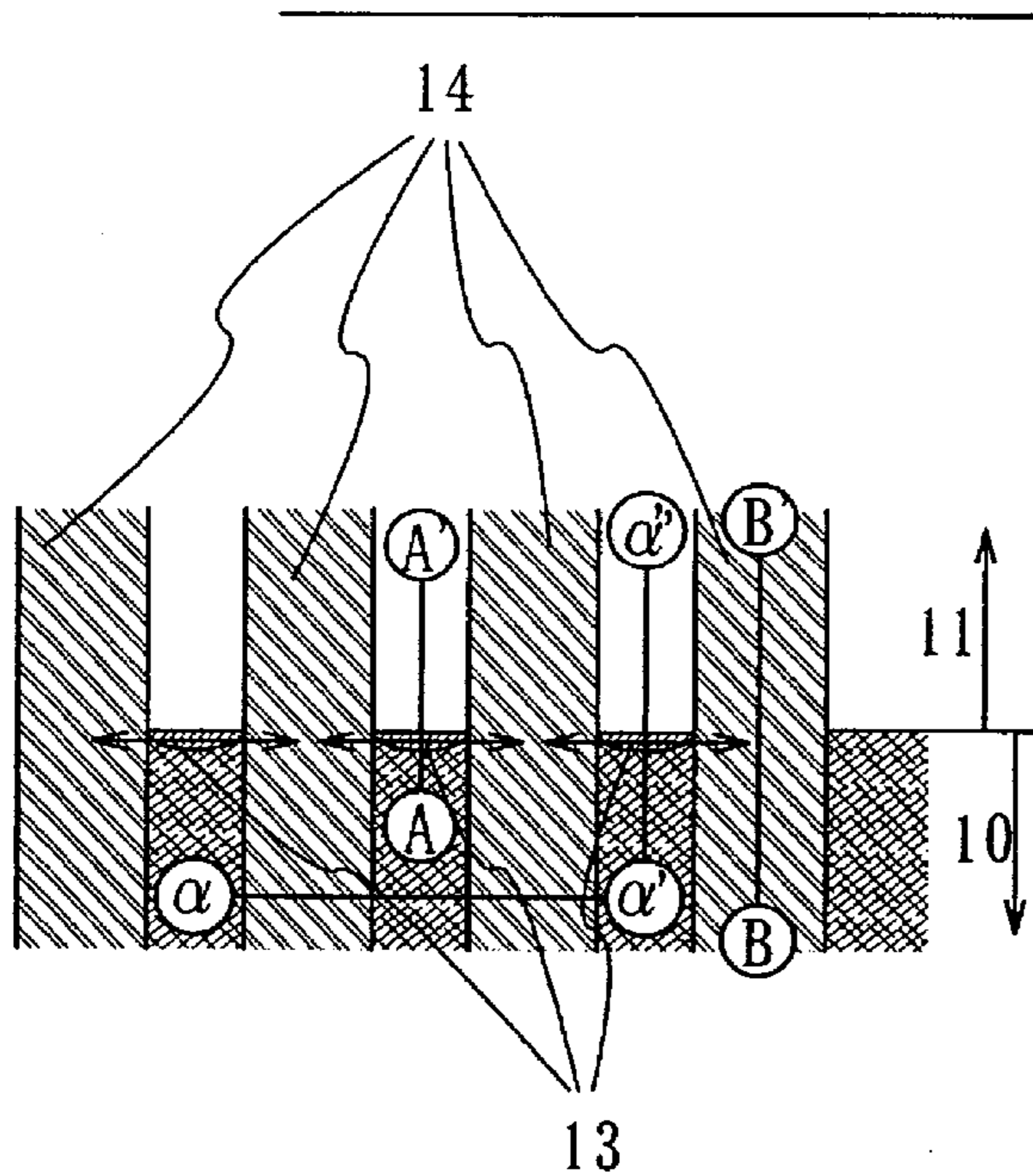
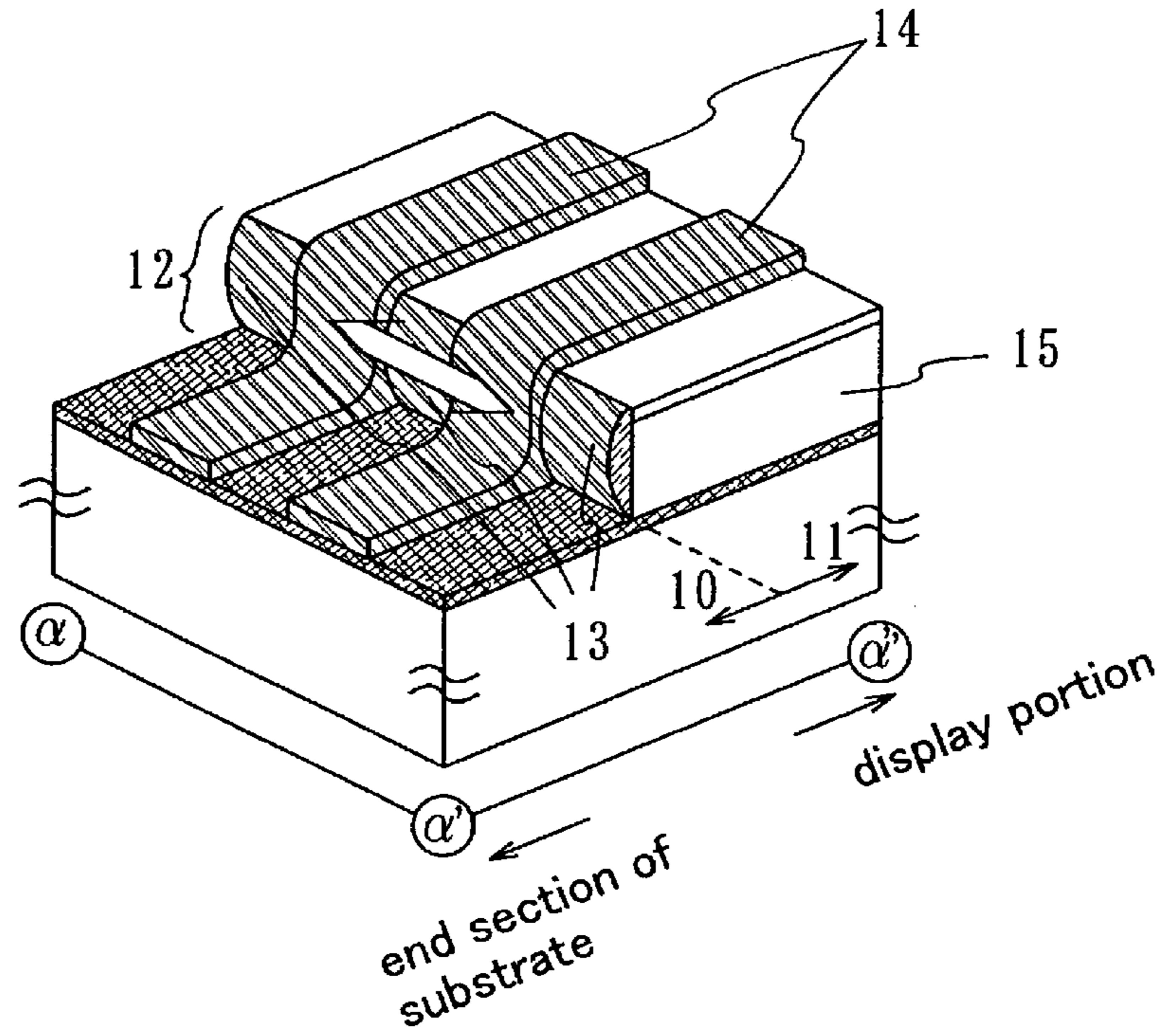

Fig. 8B

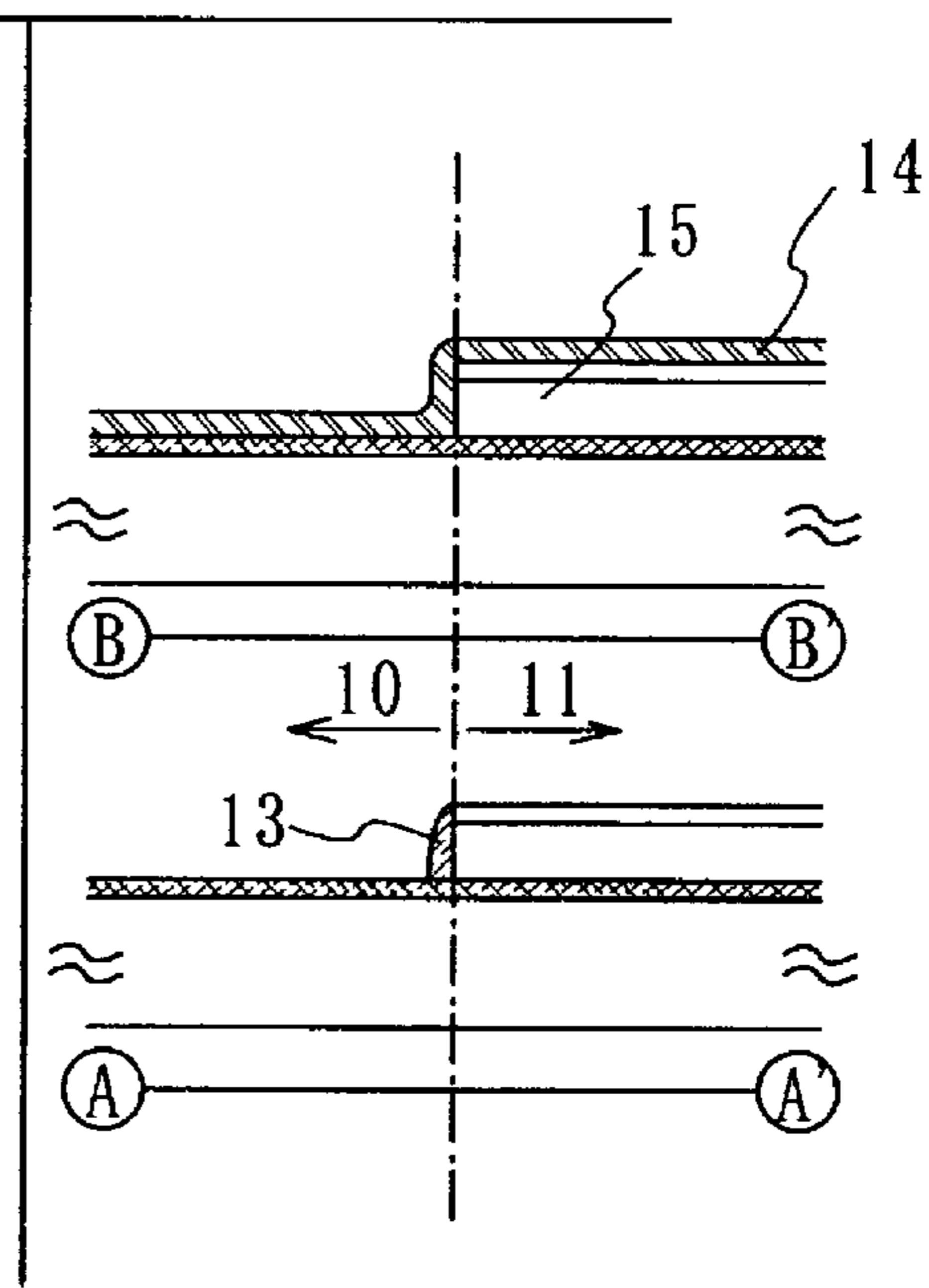

Fig. 8C

Fig. 9A

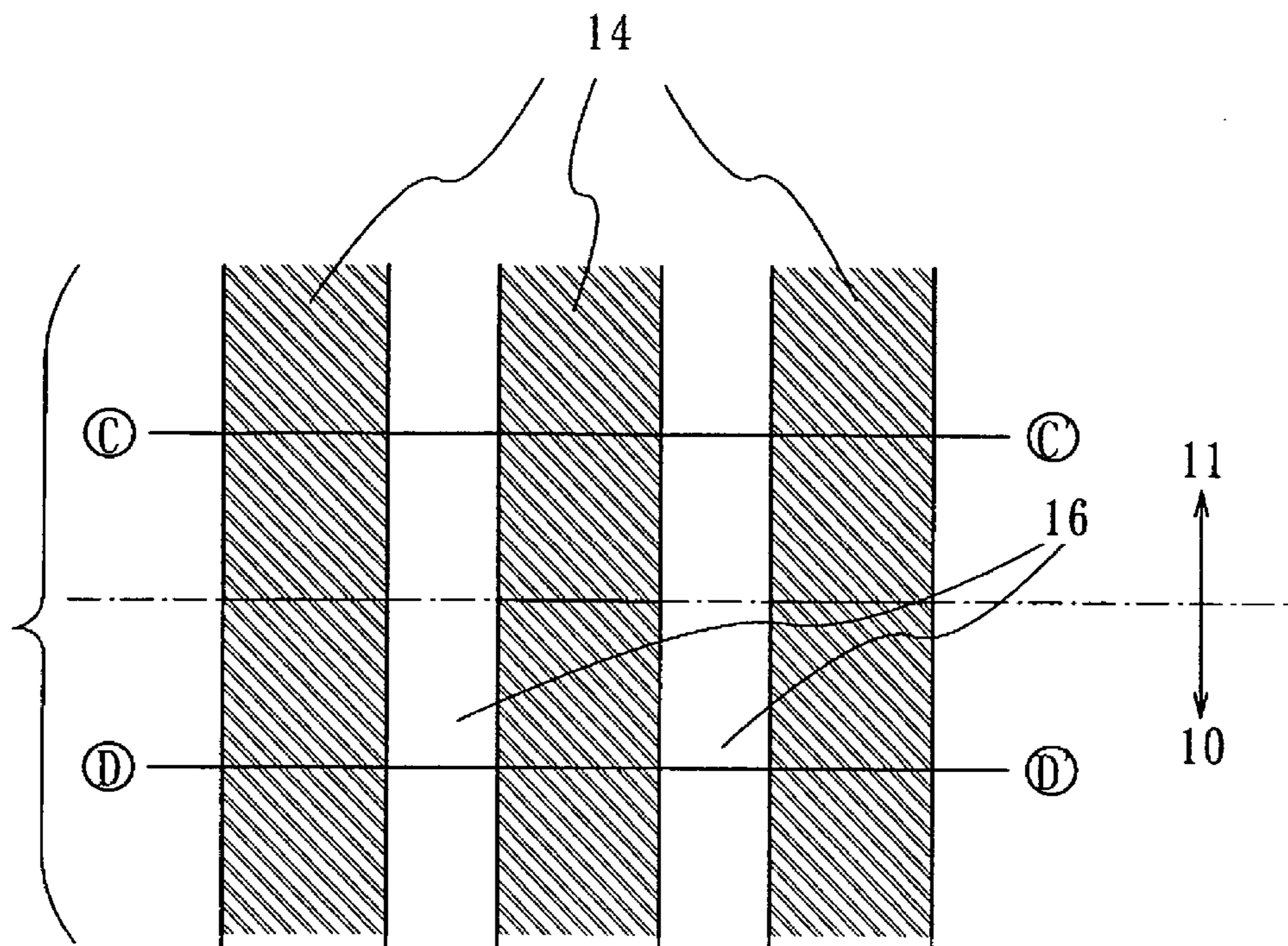

Fig. 9B

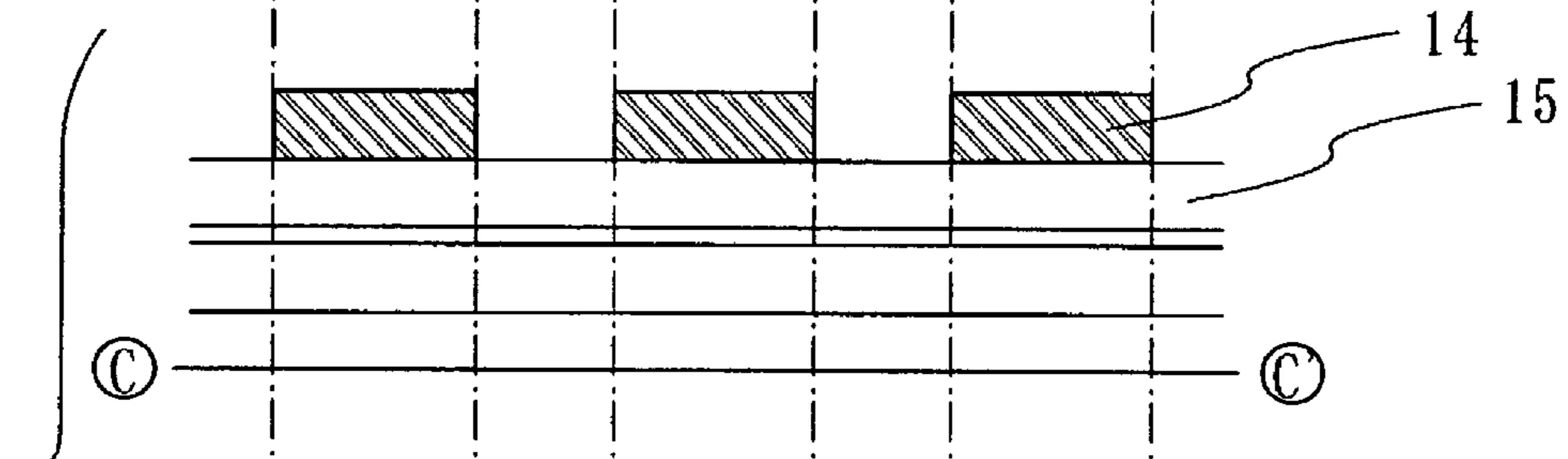

Fig. 9C

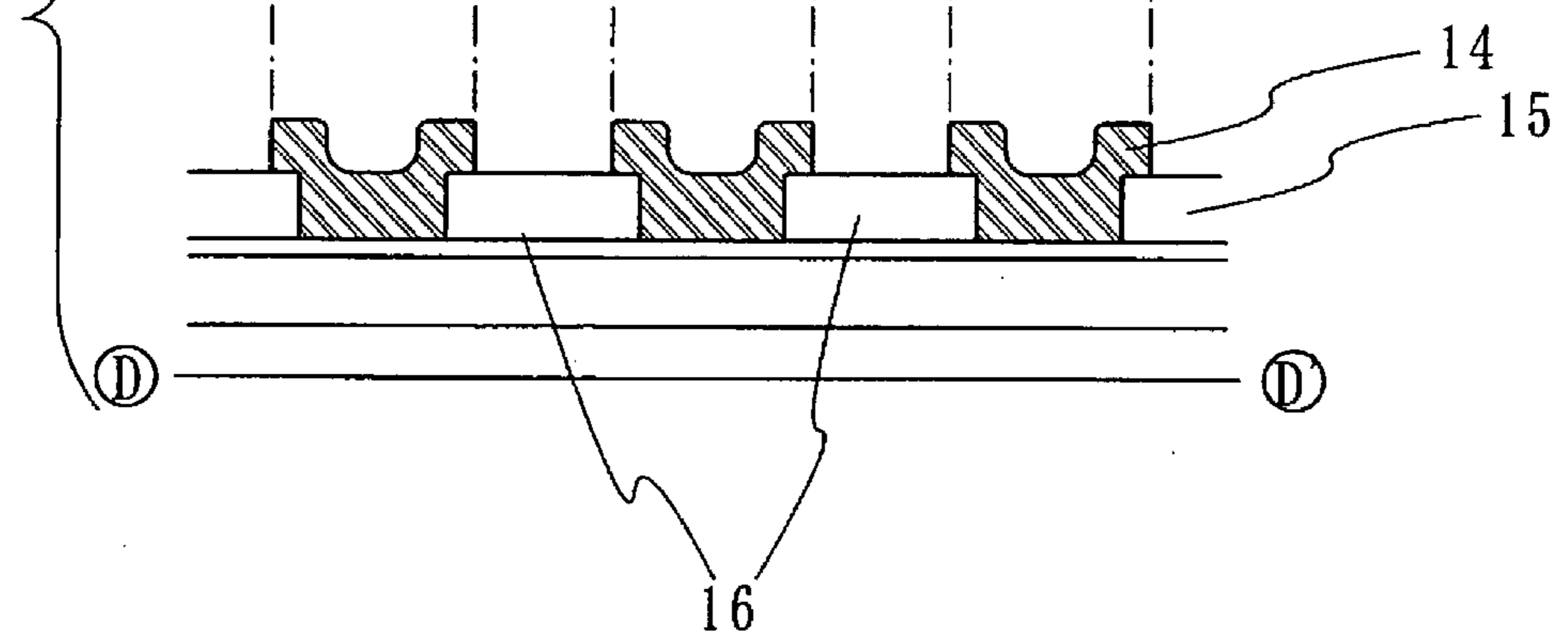

Fig. 10A

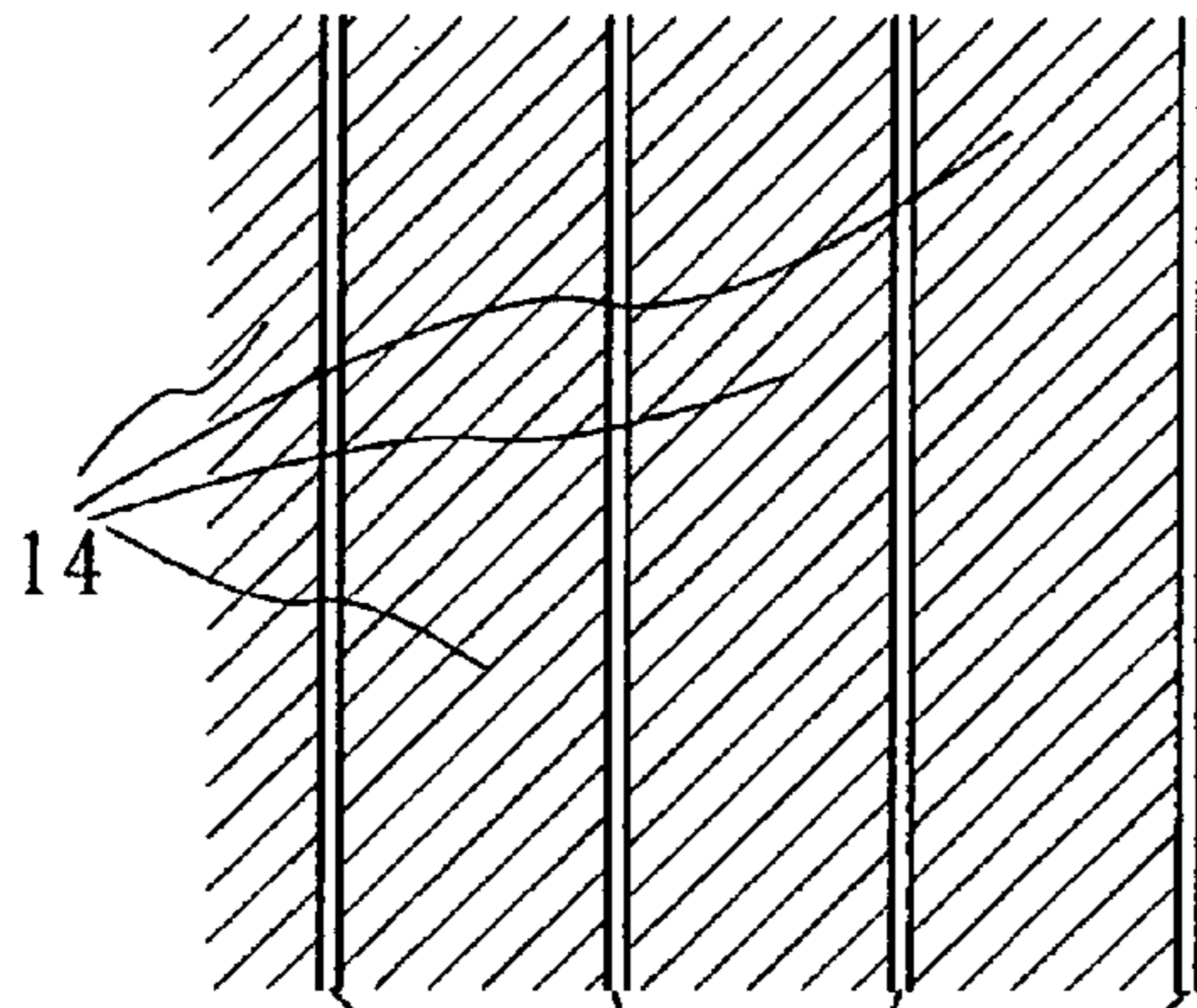

Fig. 10D

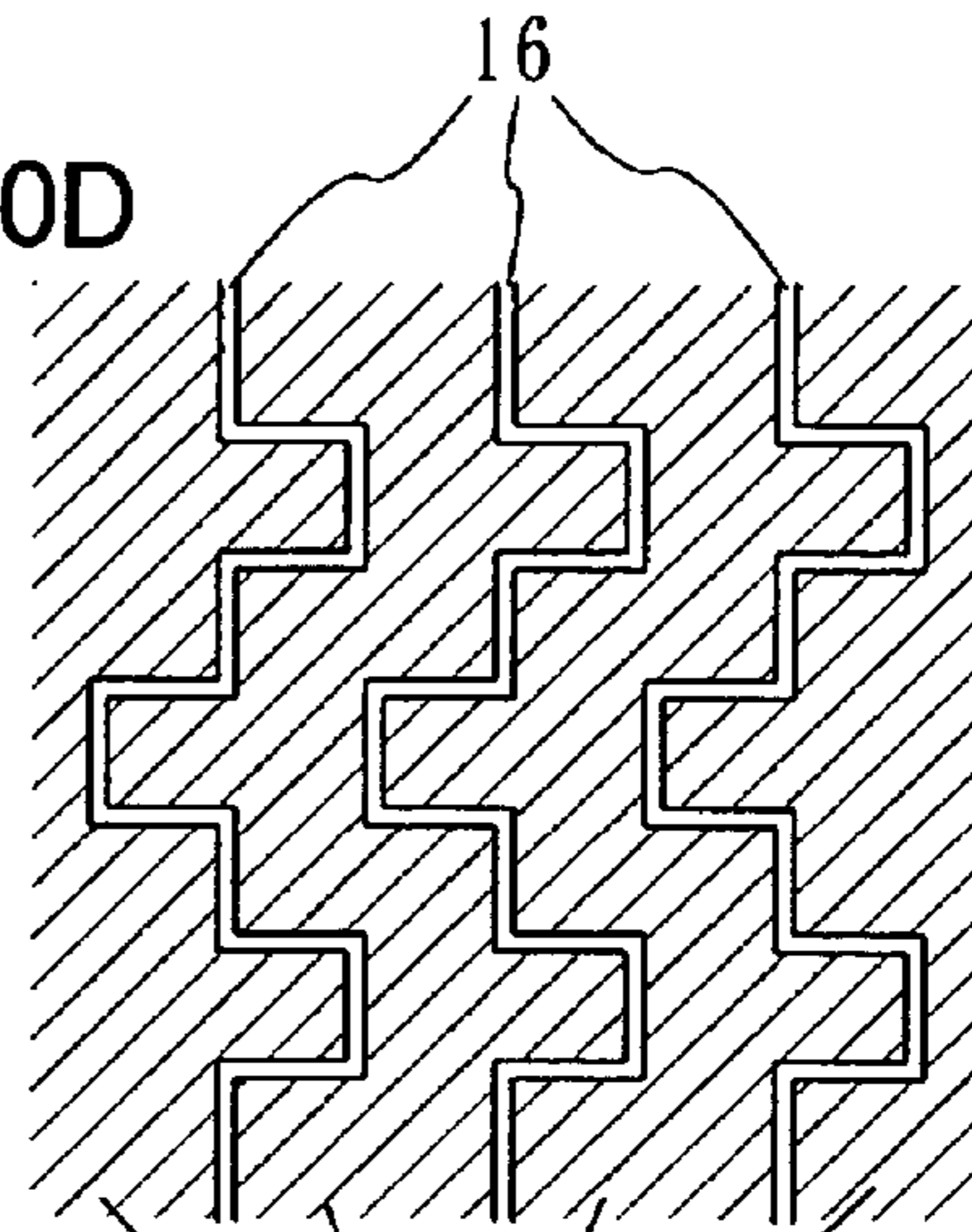

Fig. 10B

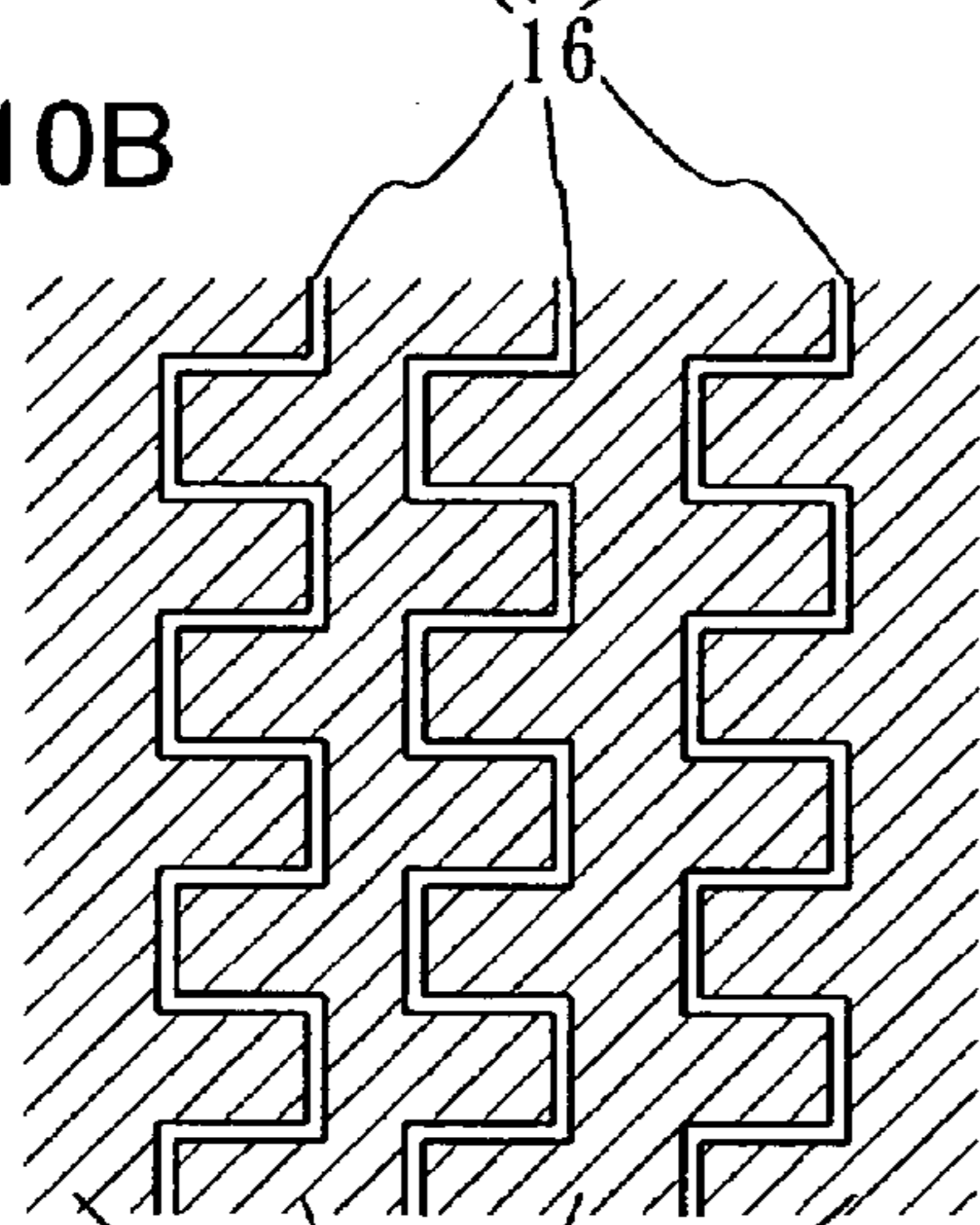

Fig. 10E

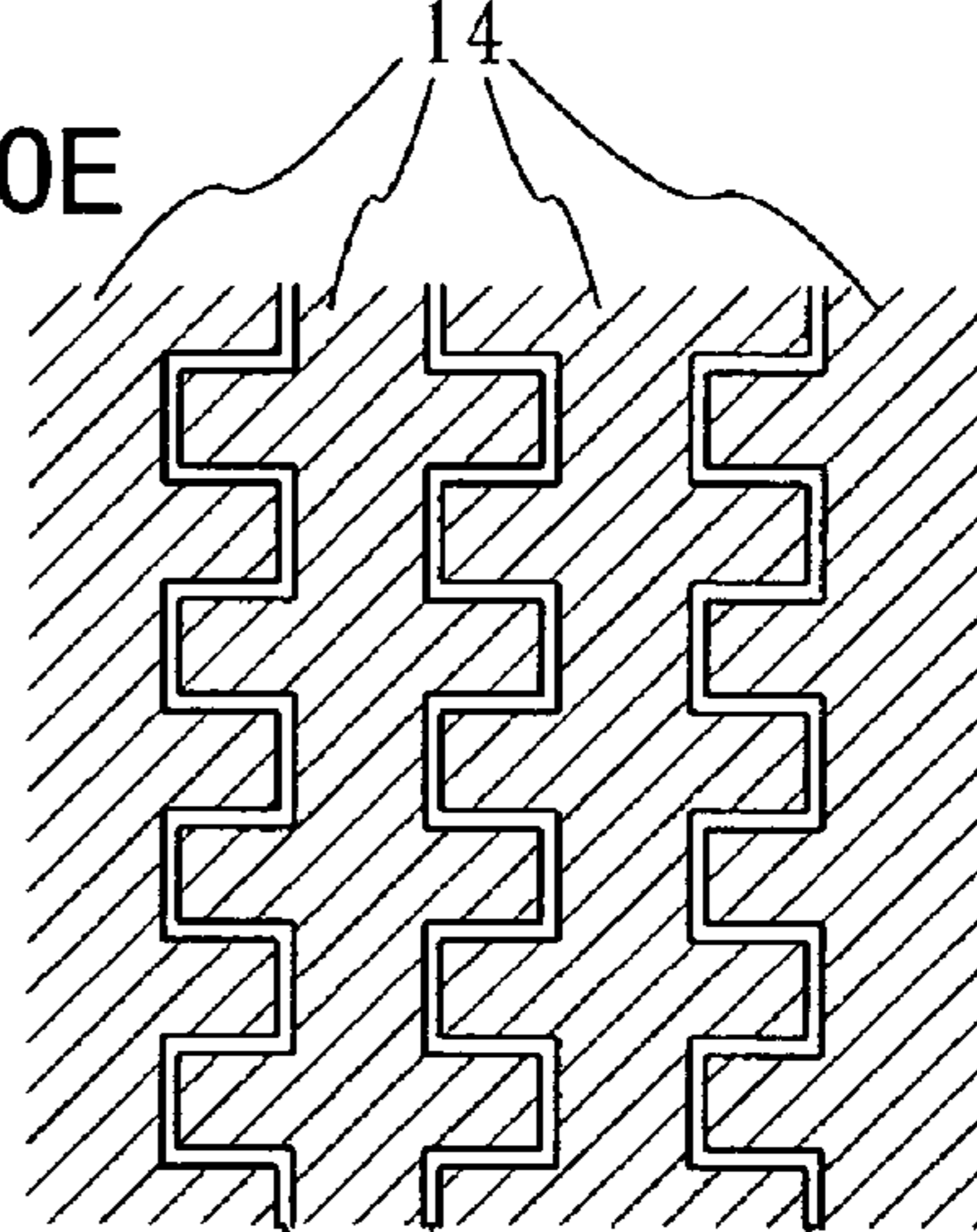

Fig. 10C

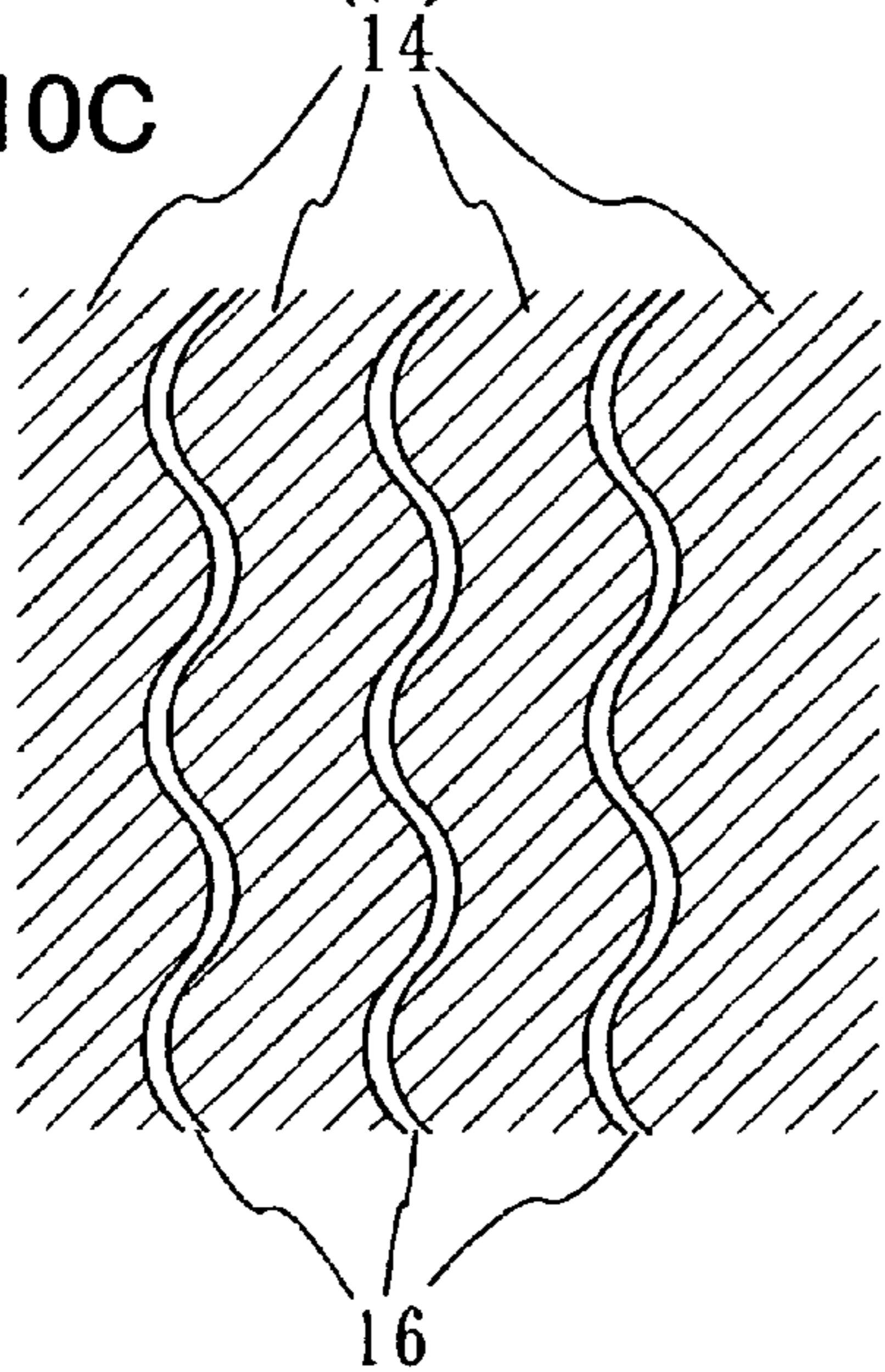

Fig. 10F

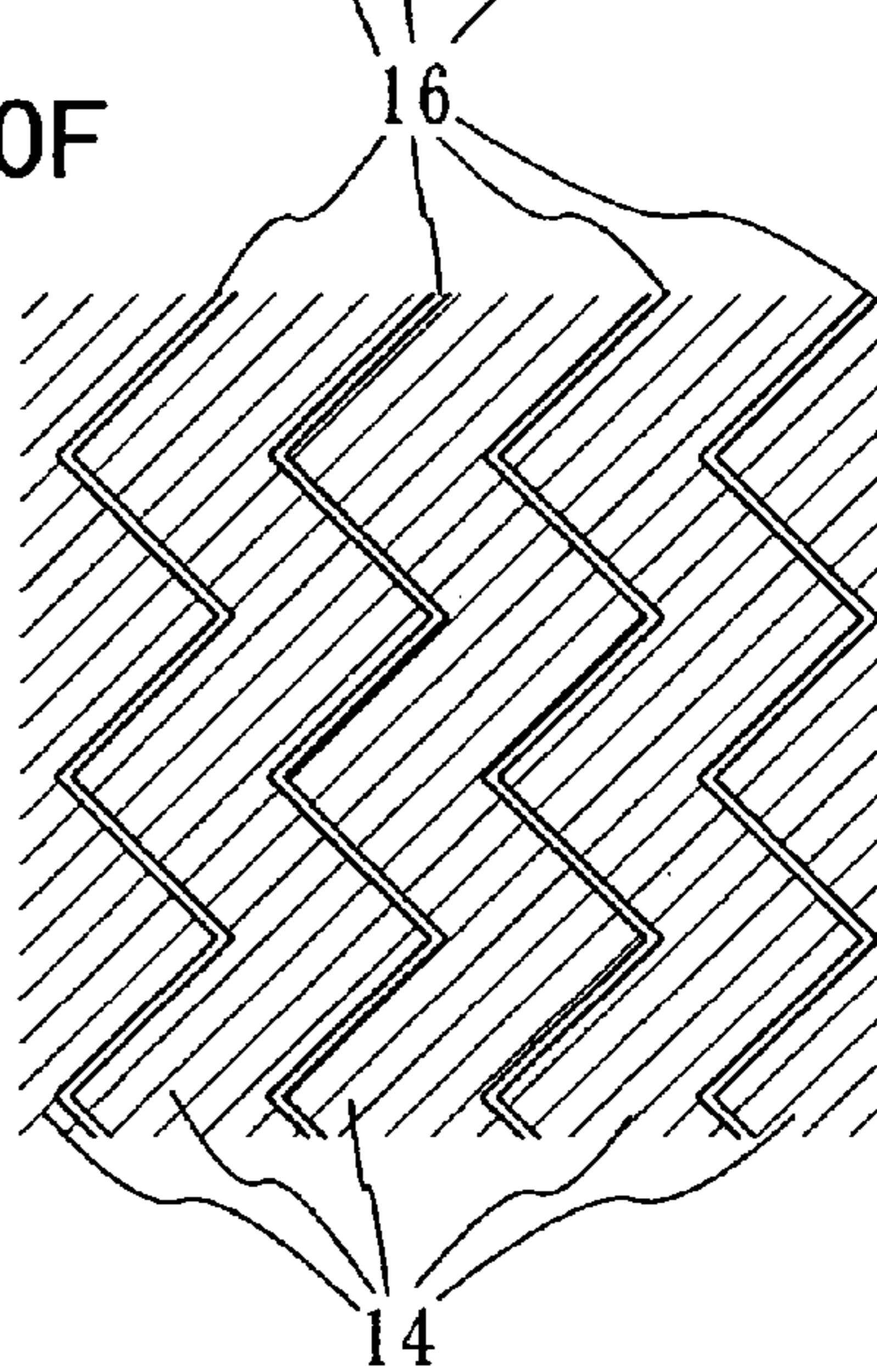

Fig. 11A

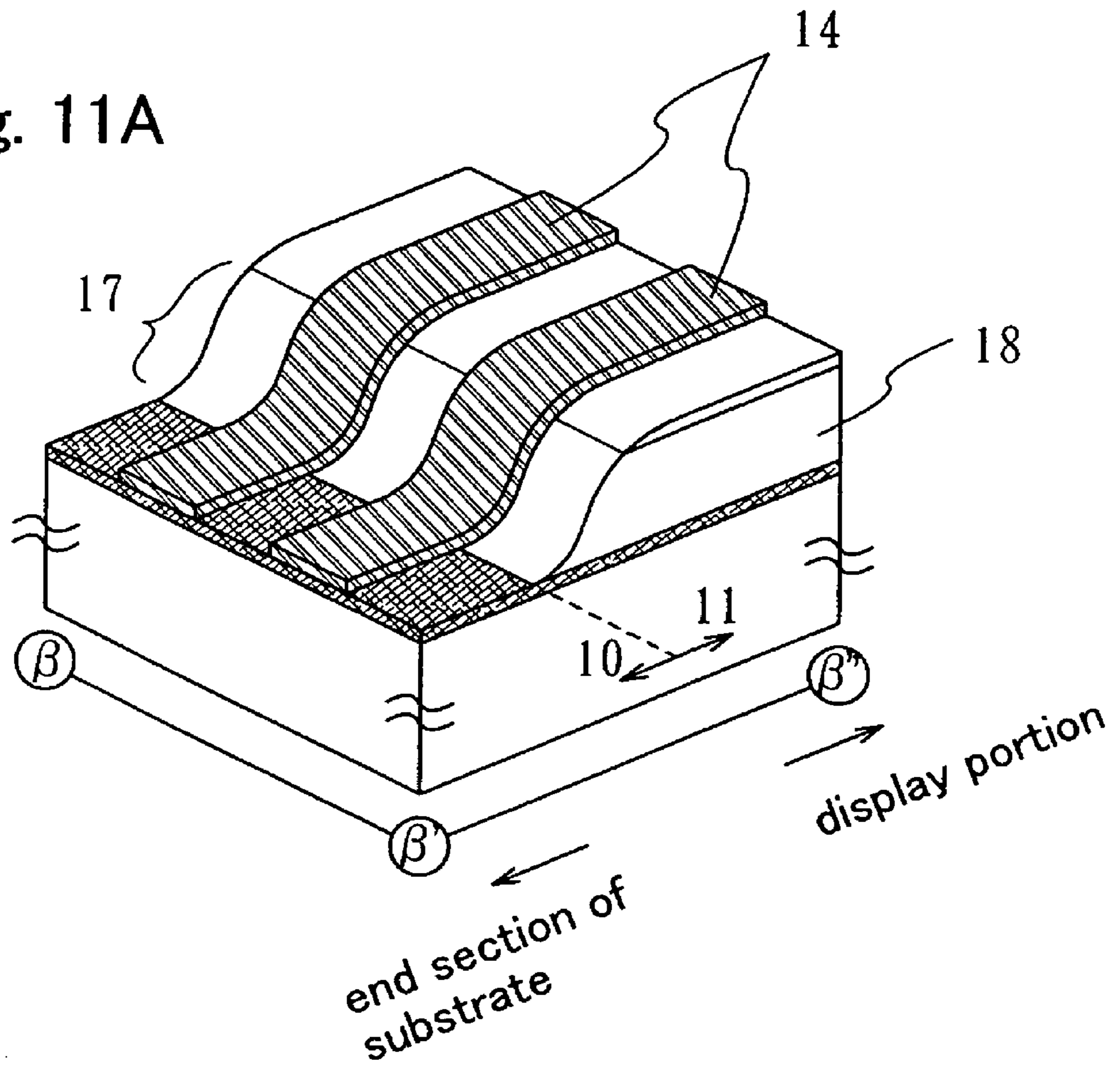

Fig. 11B

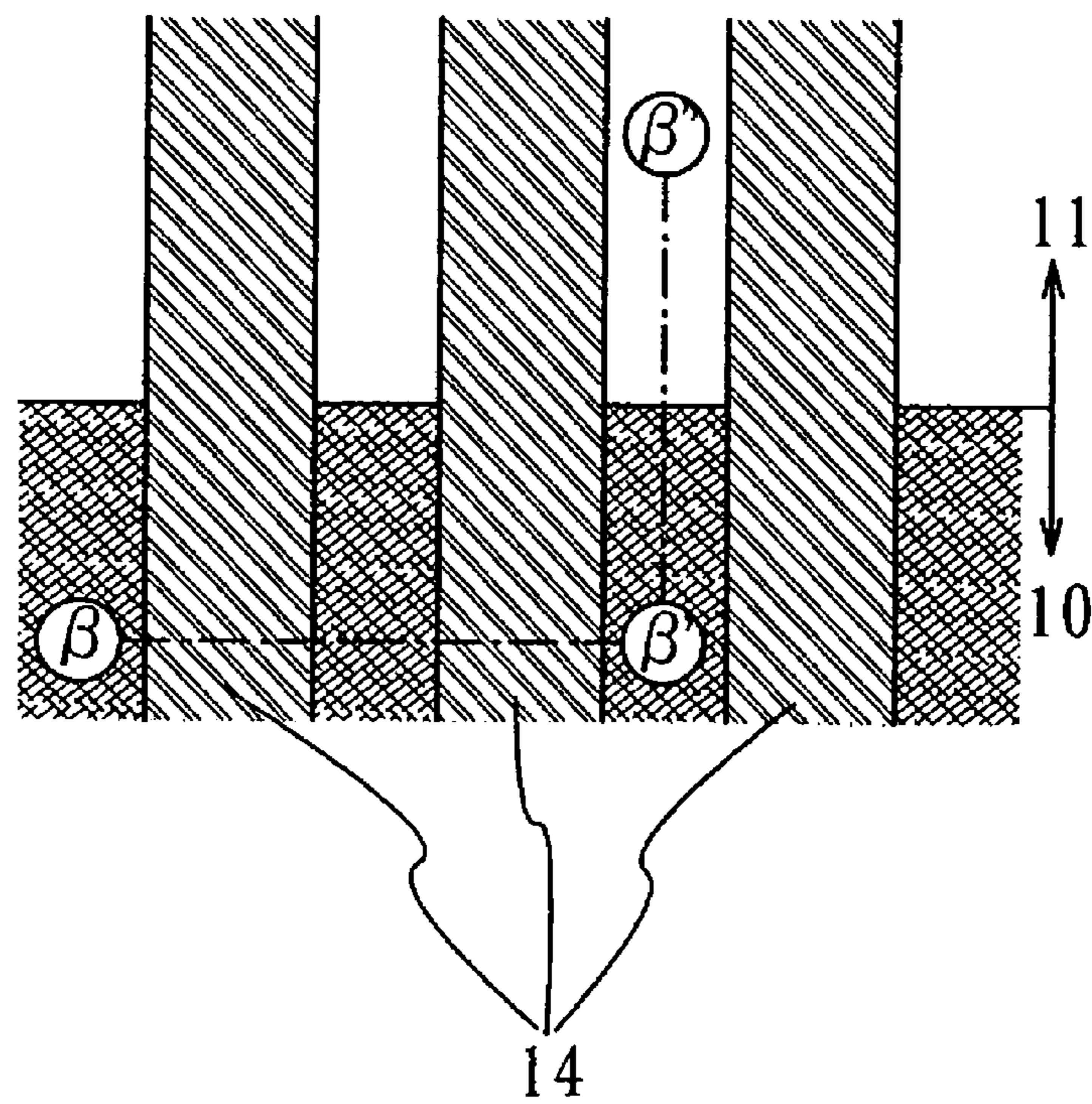

Fig. 12A

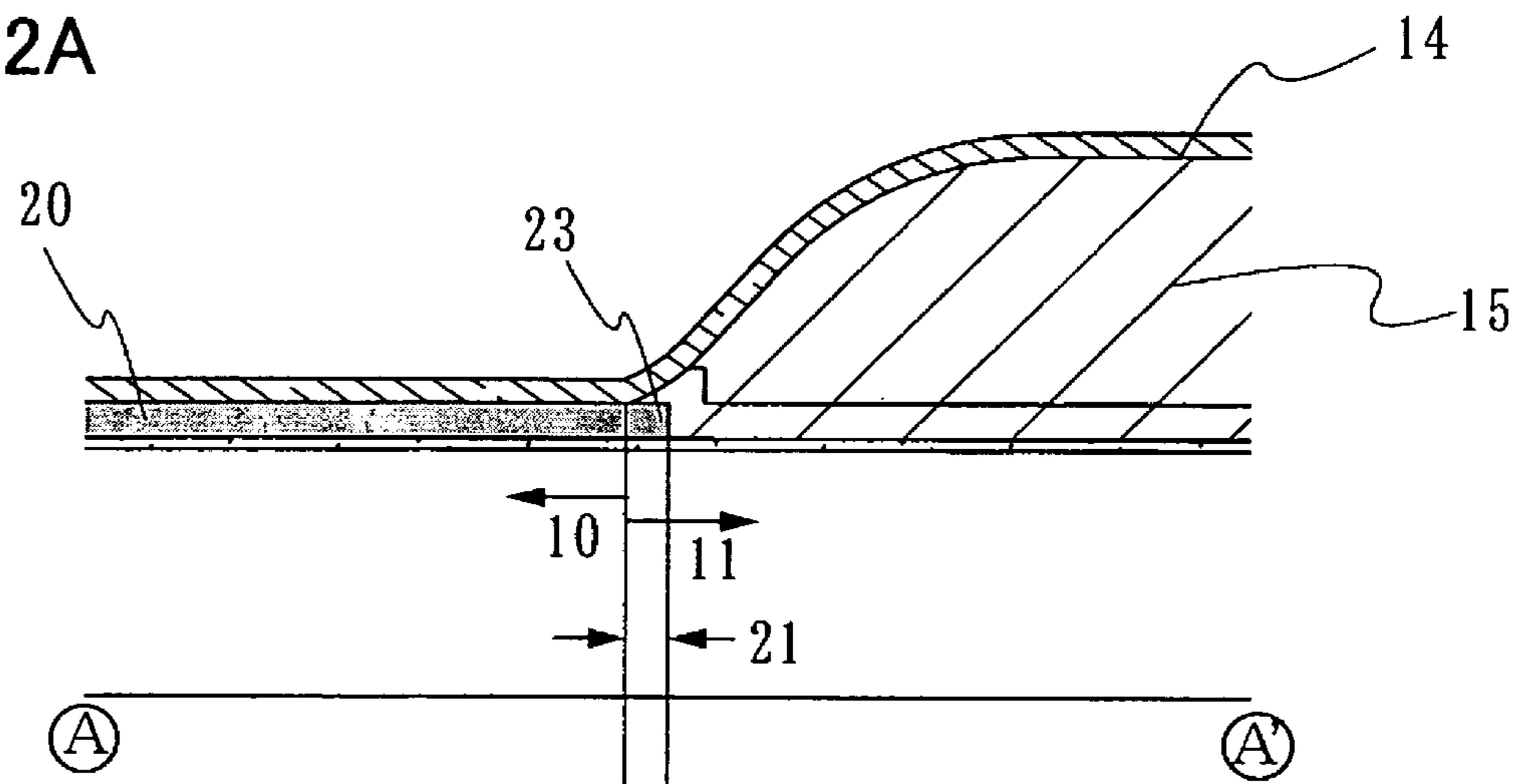

Fig. 12B

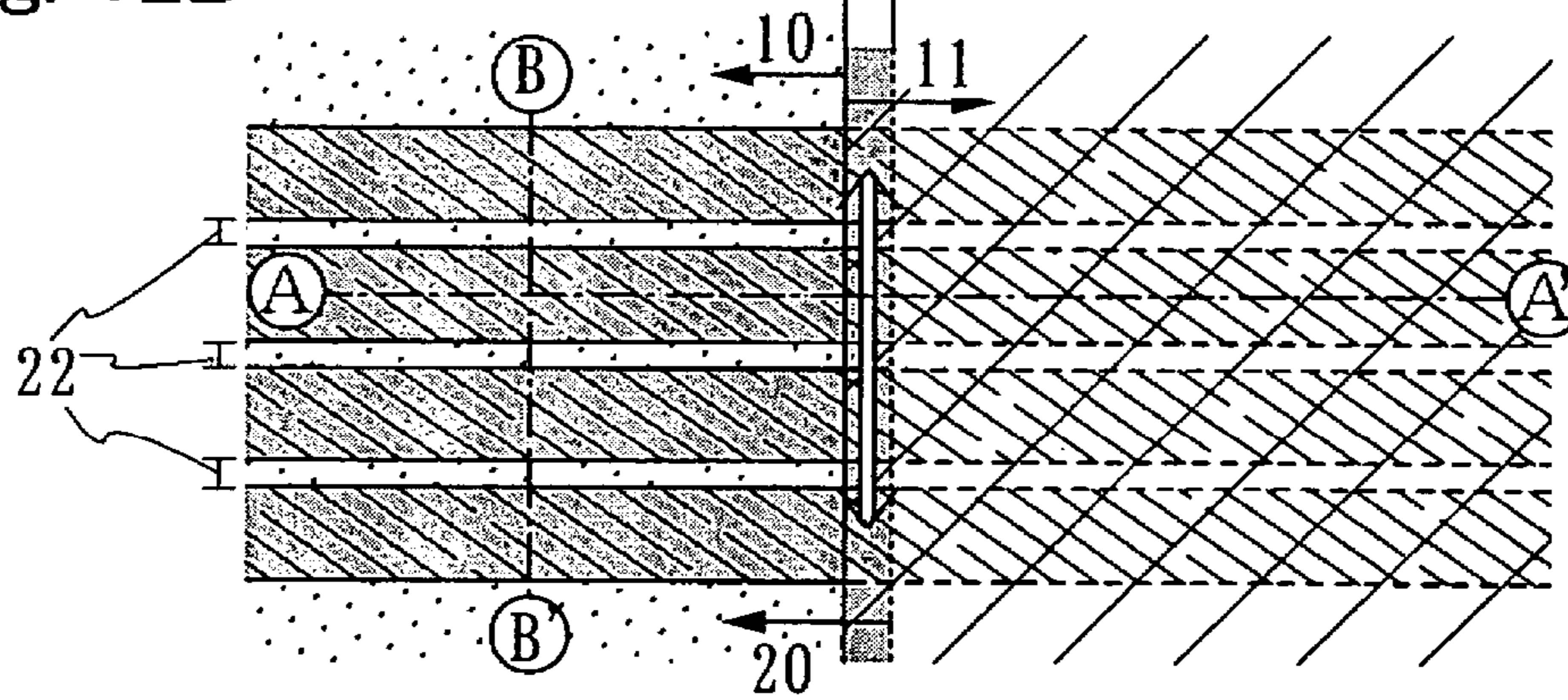

Fig. 12C

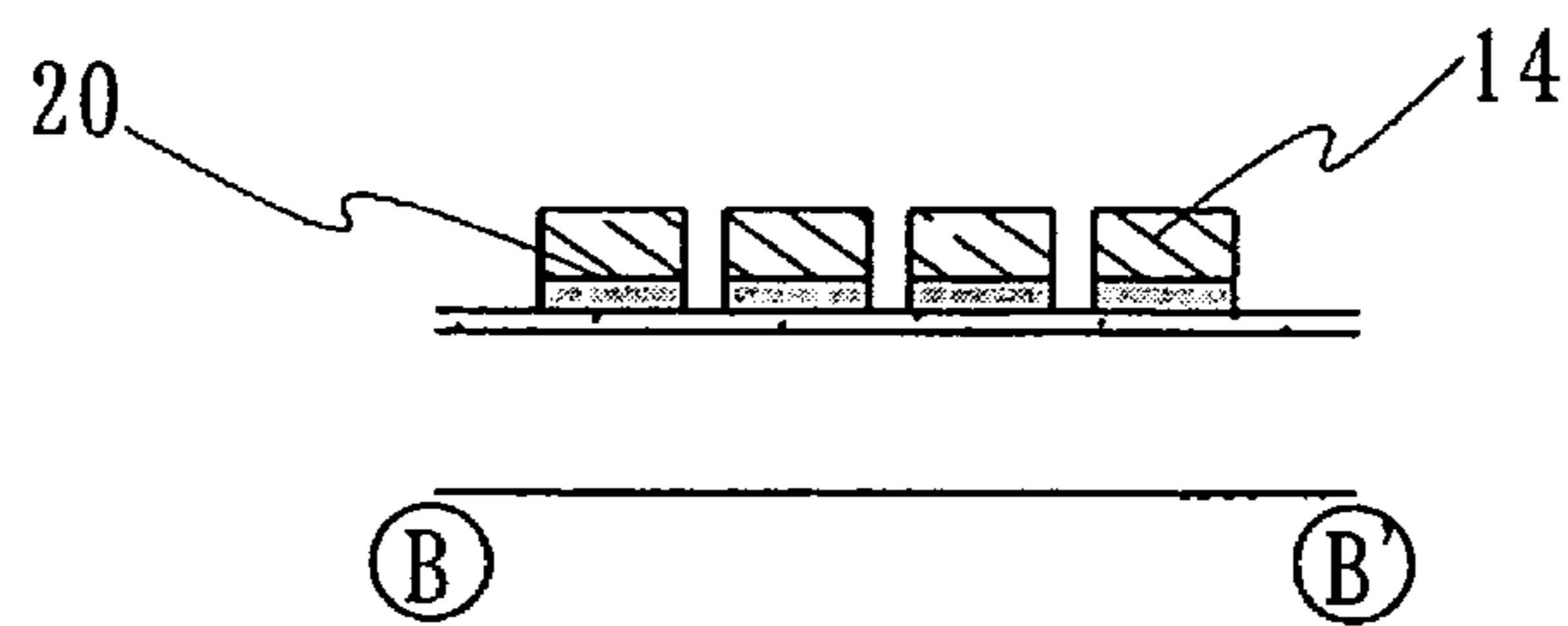

Fig. 13A

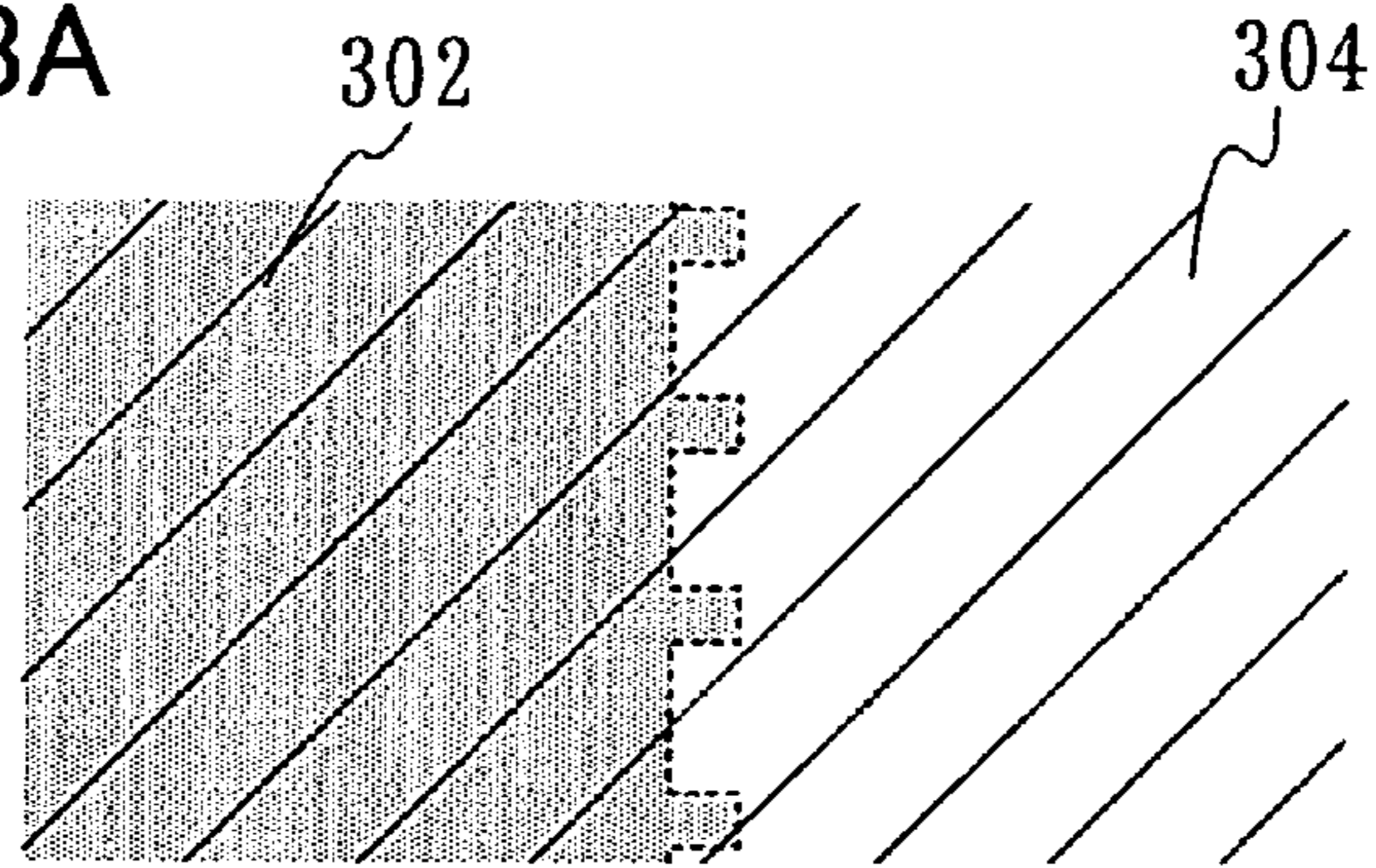

Fig. 13B

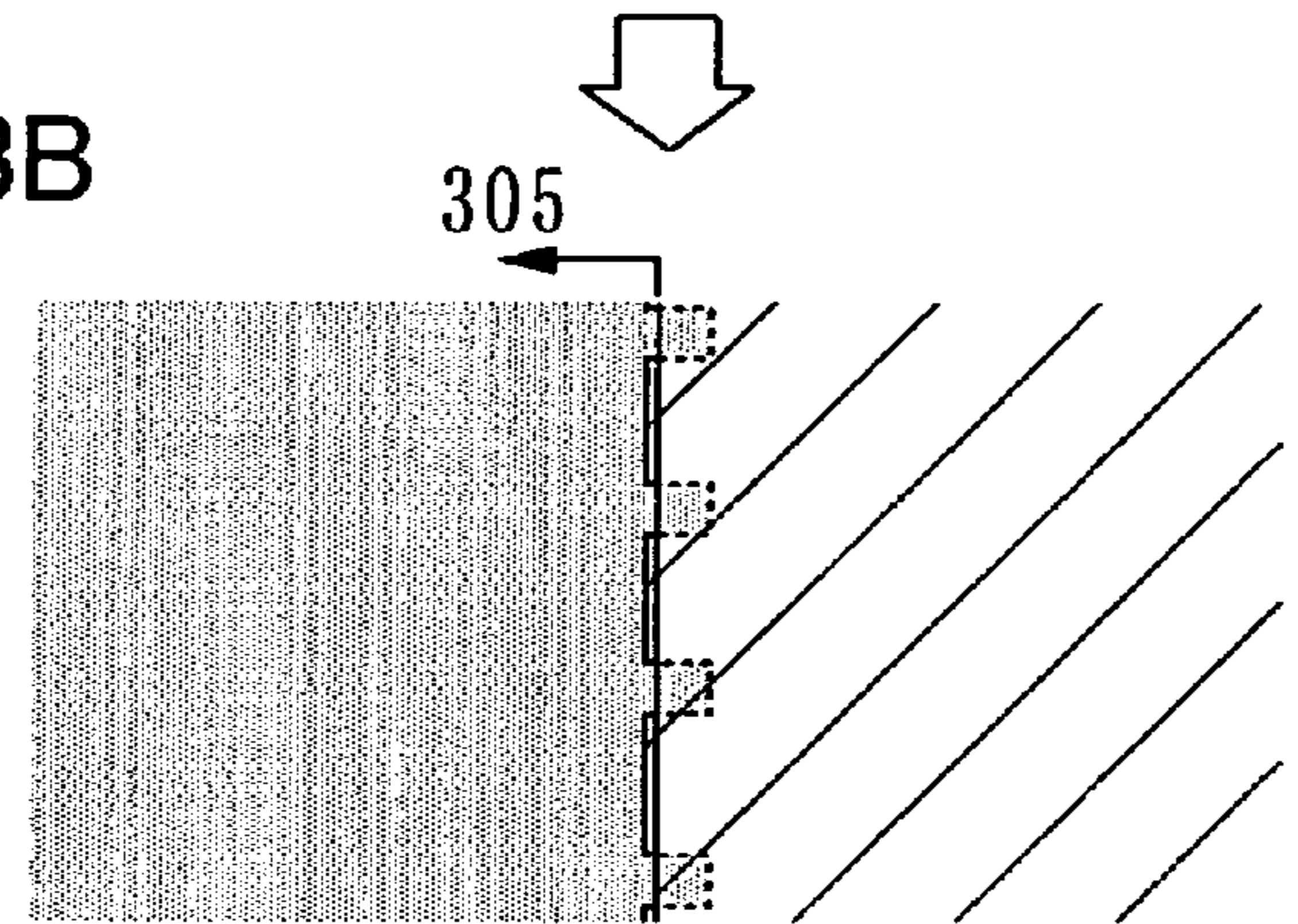

Fig. 13C

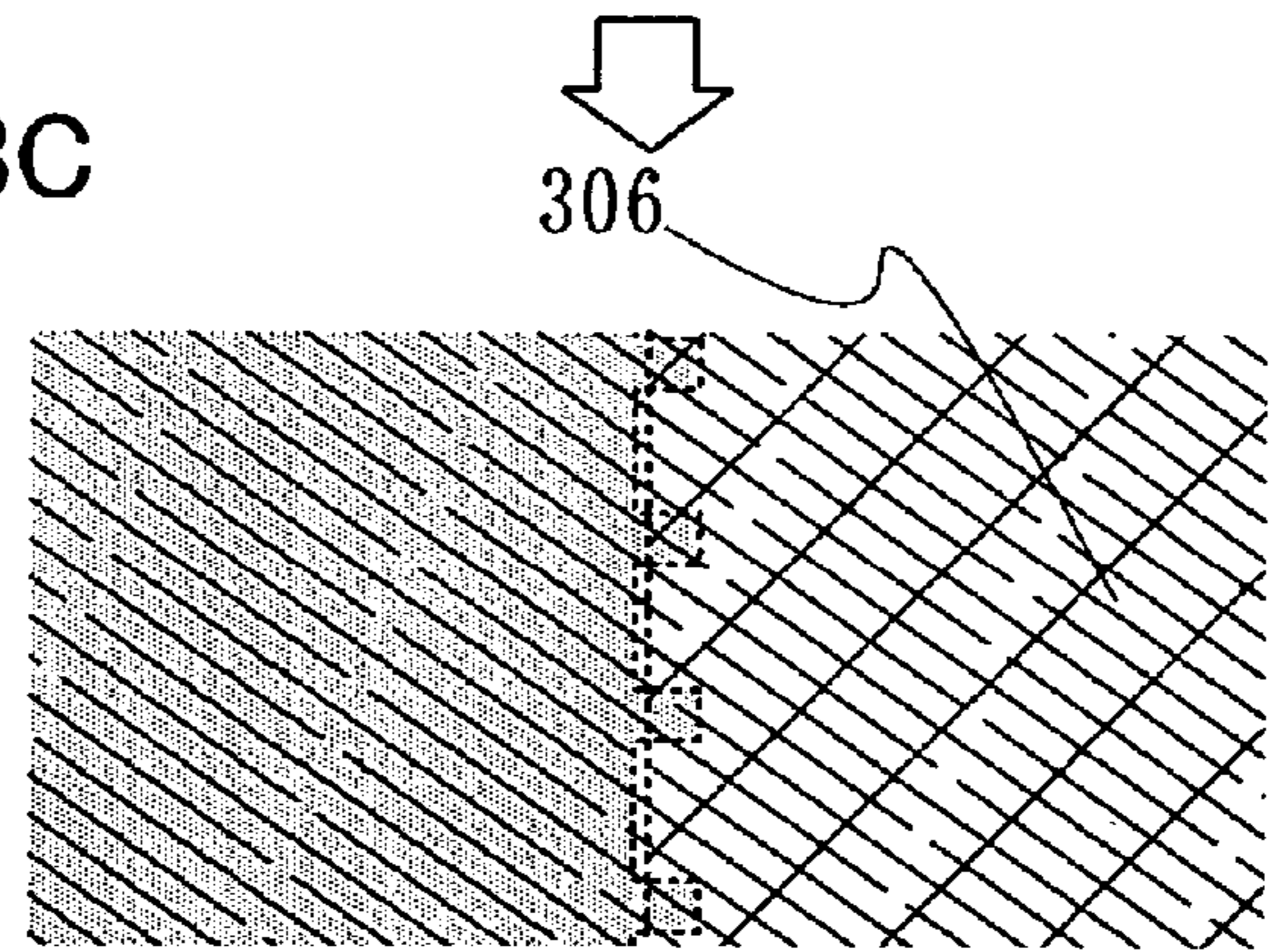

Fig. 13D

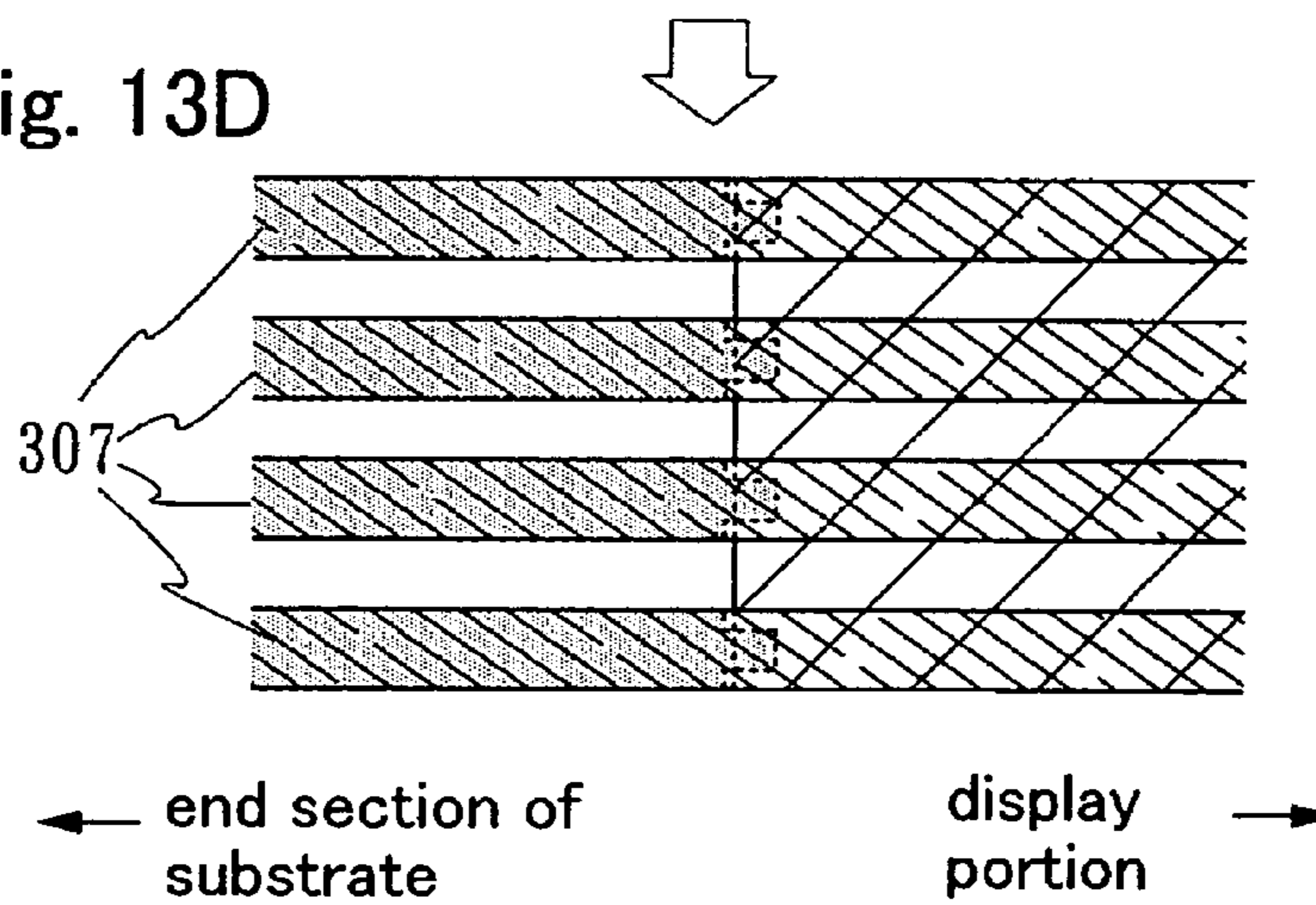

Fig. 14A

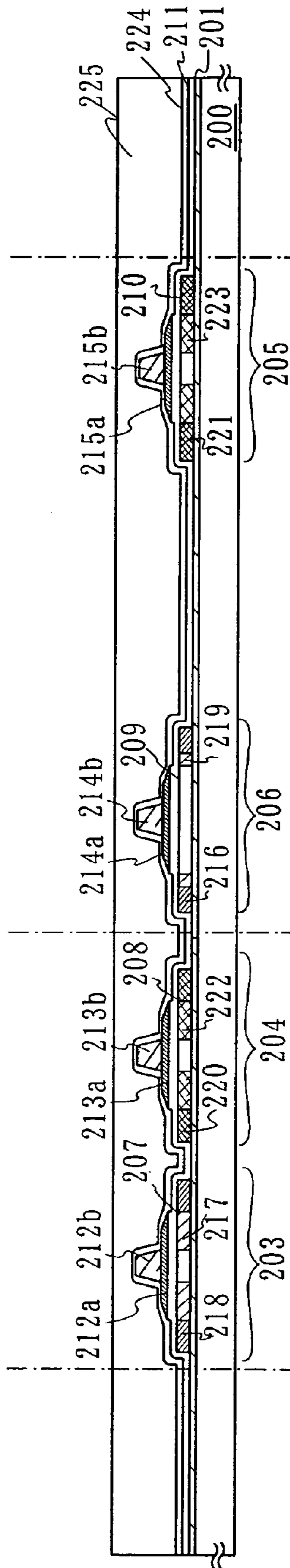
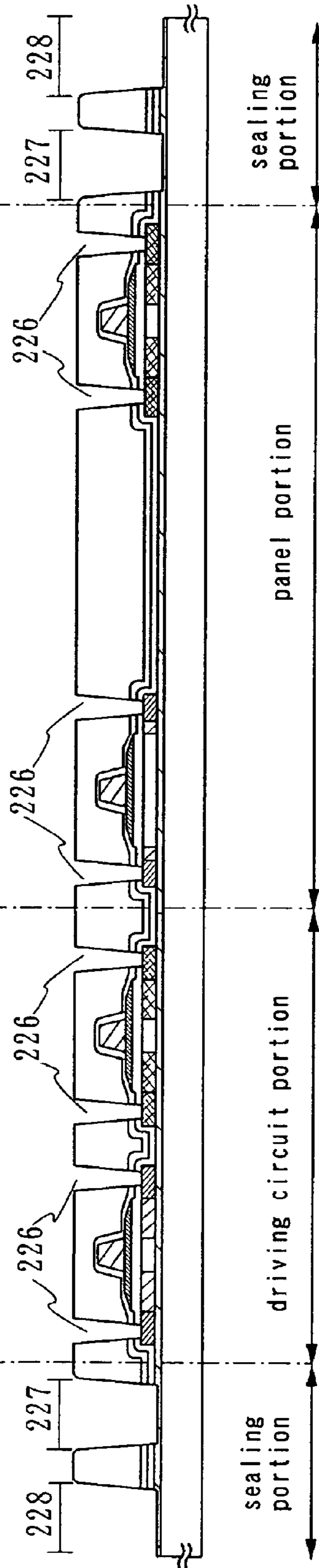
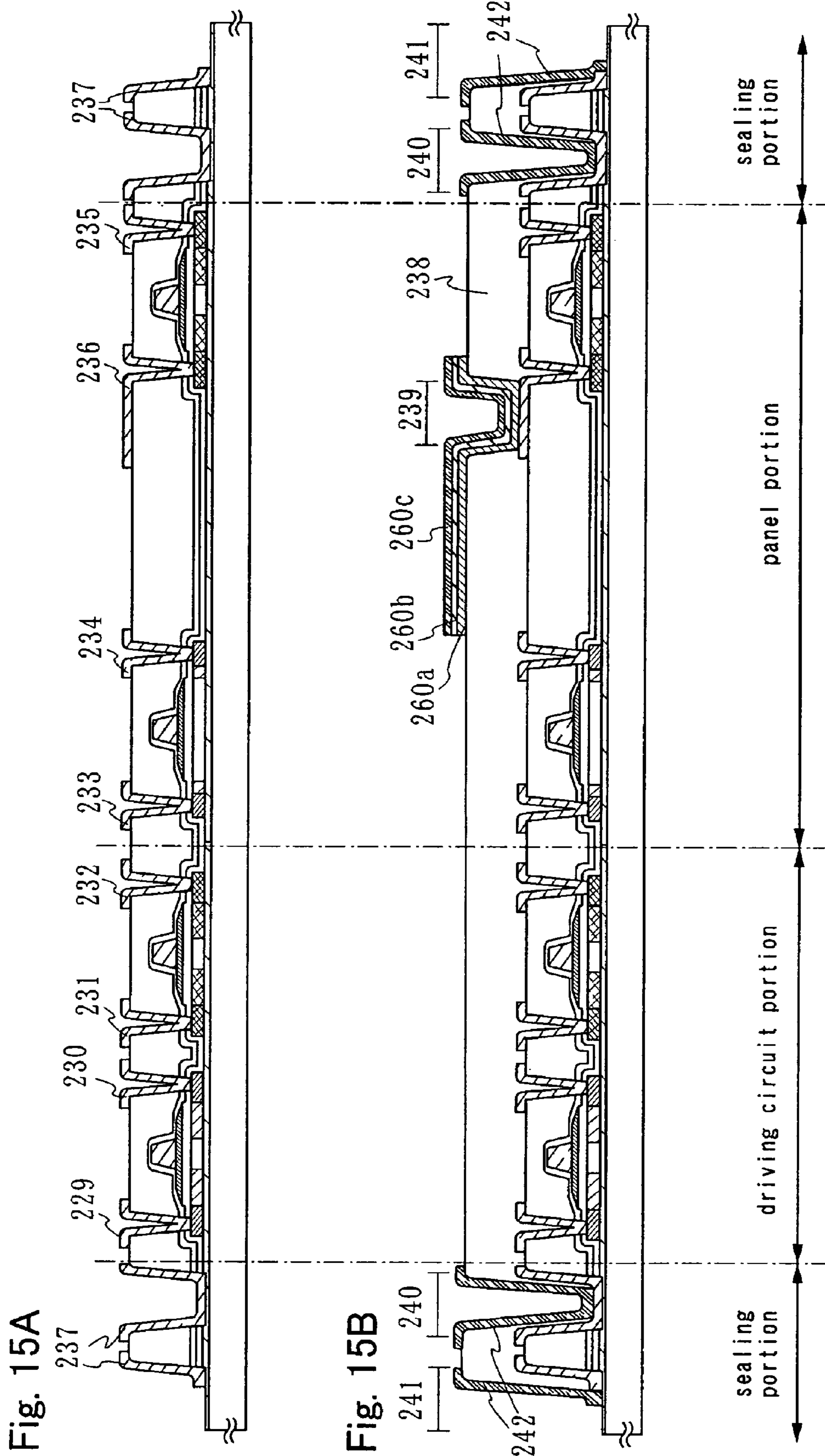

Fig. 14B





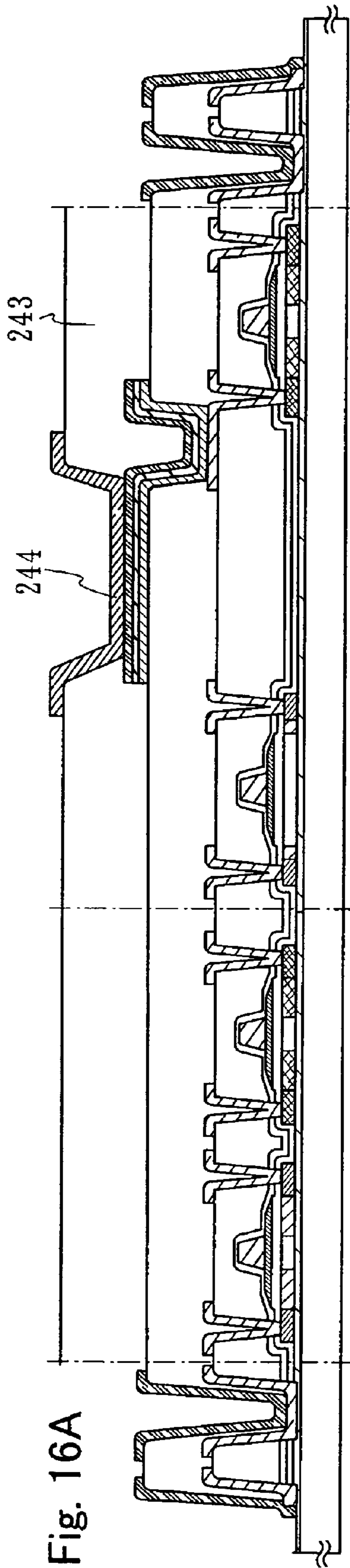

Fig. 16A

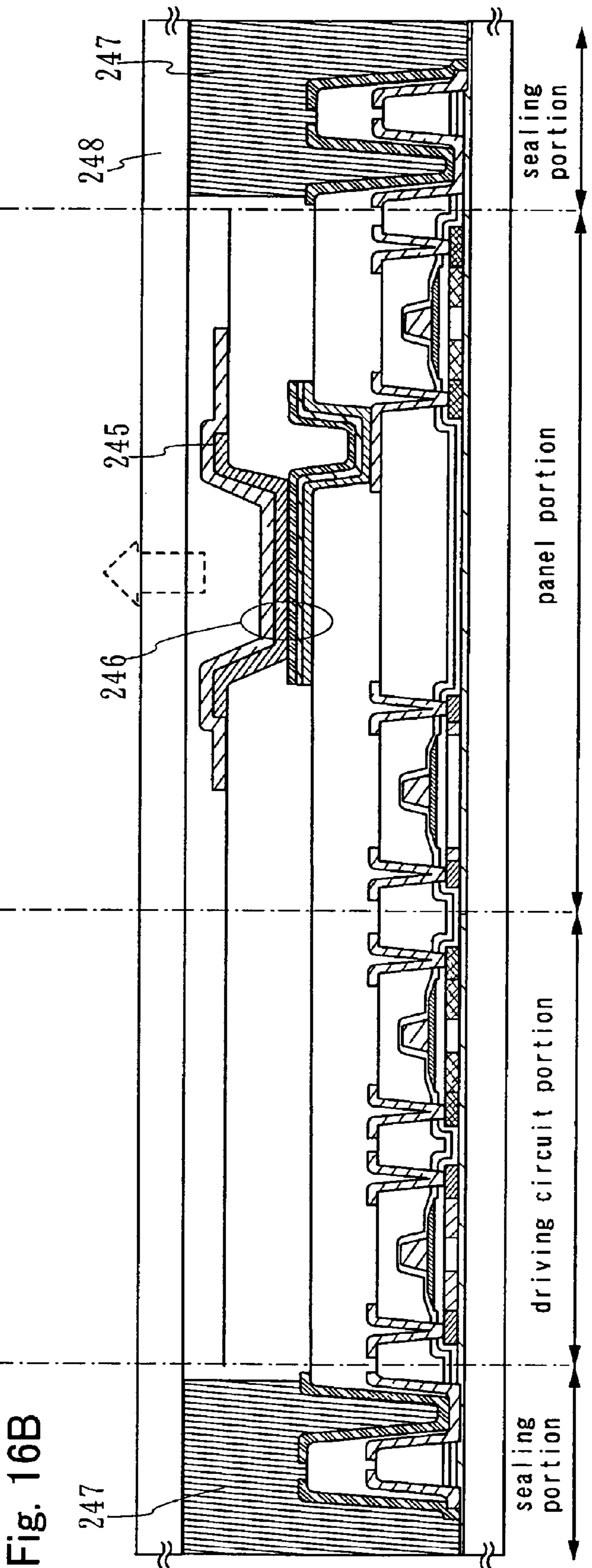

Fig. 16B

Fig. 17

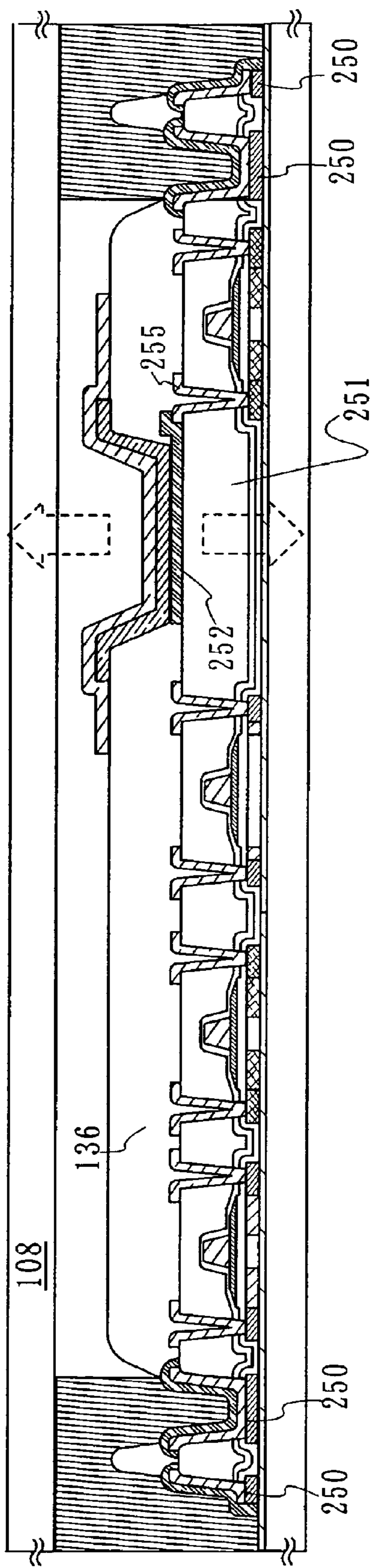

Fig. 18A

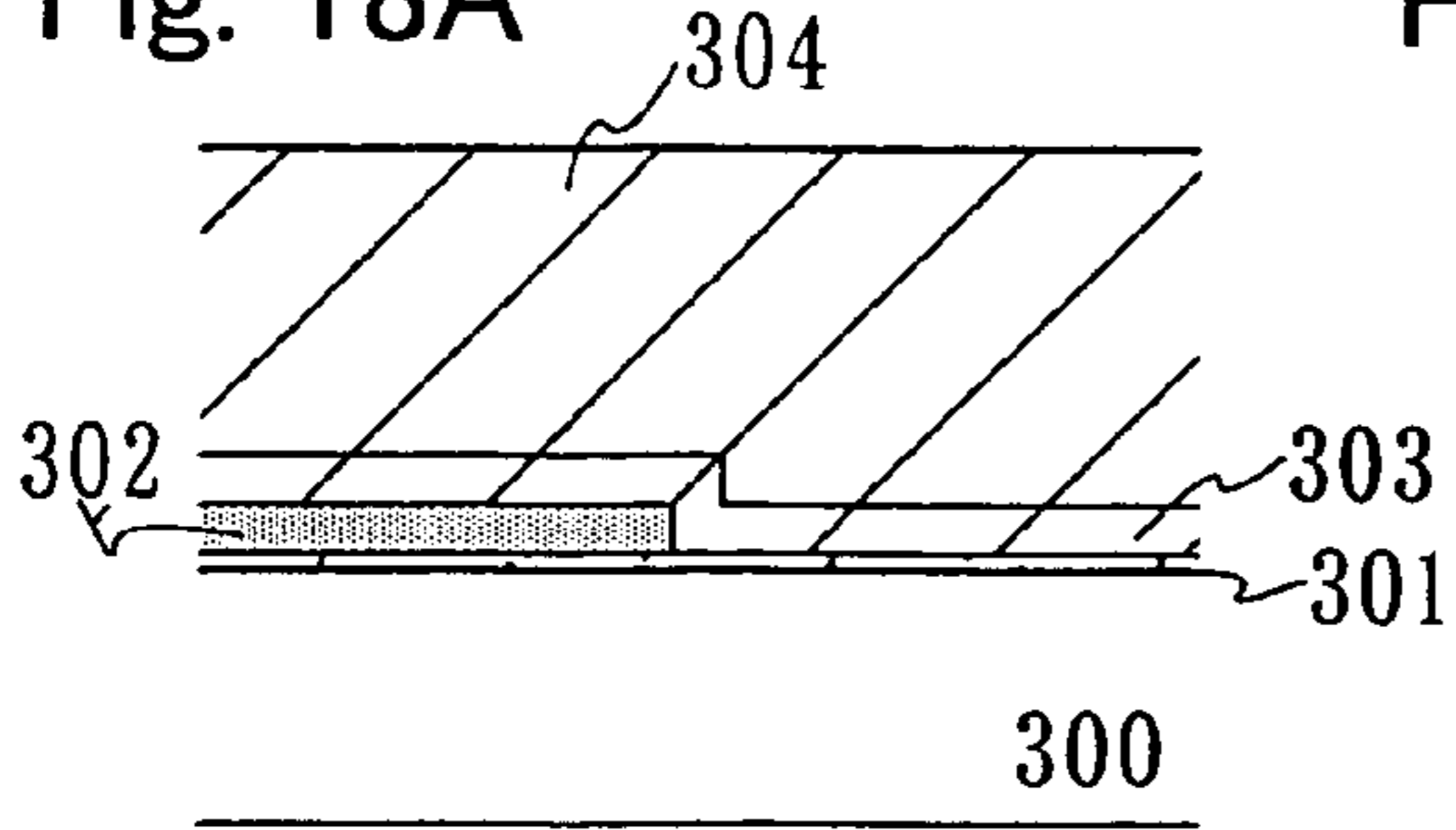

Fig. 18F

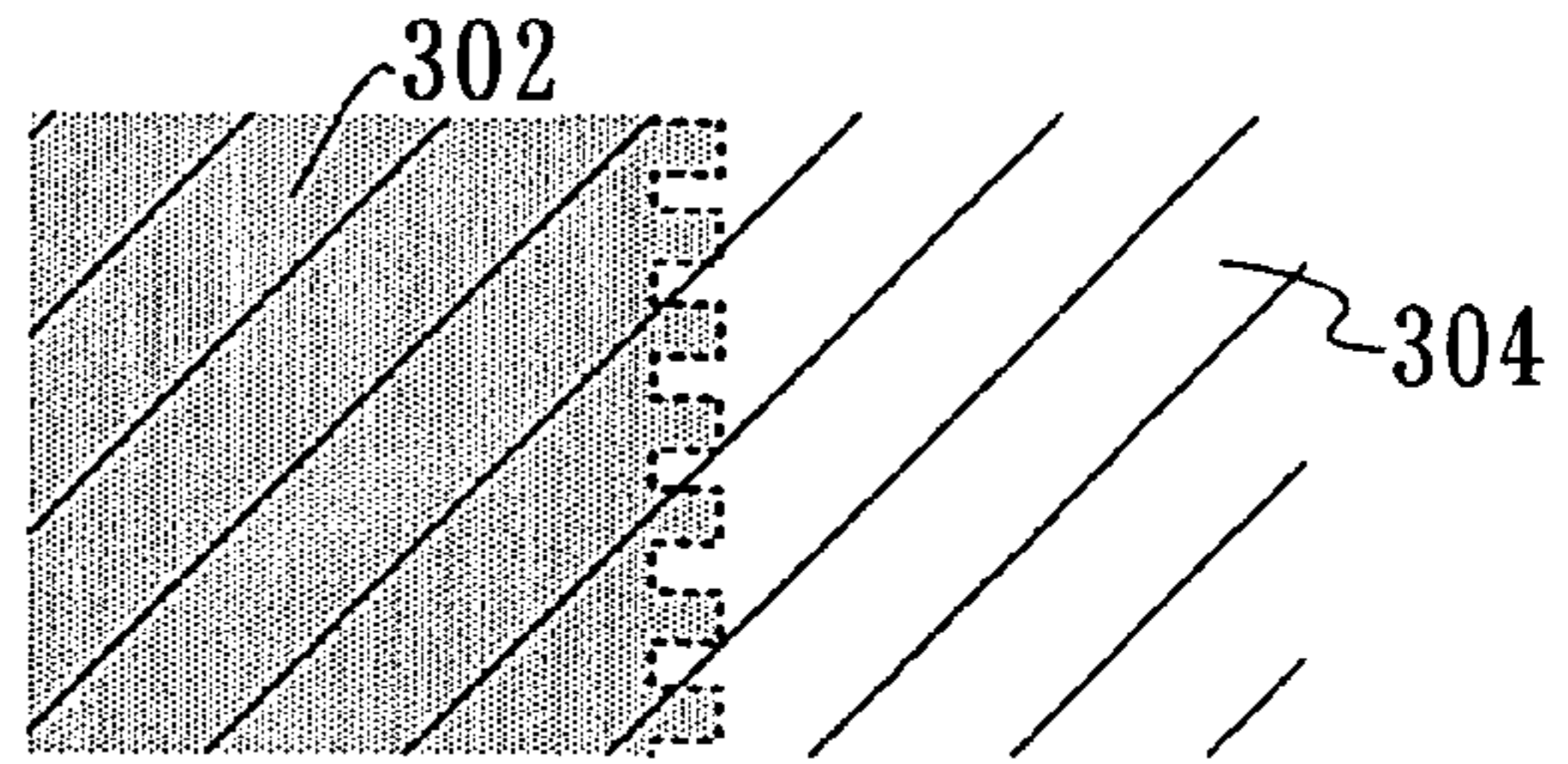

Fig. 18B

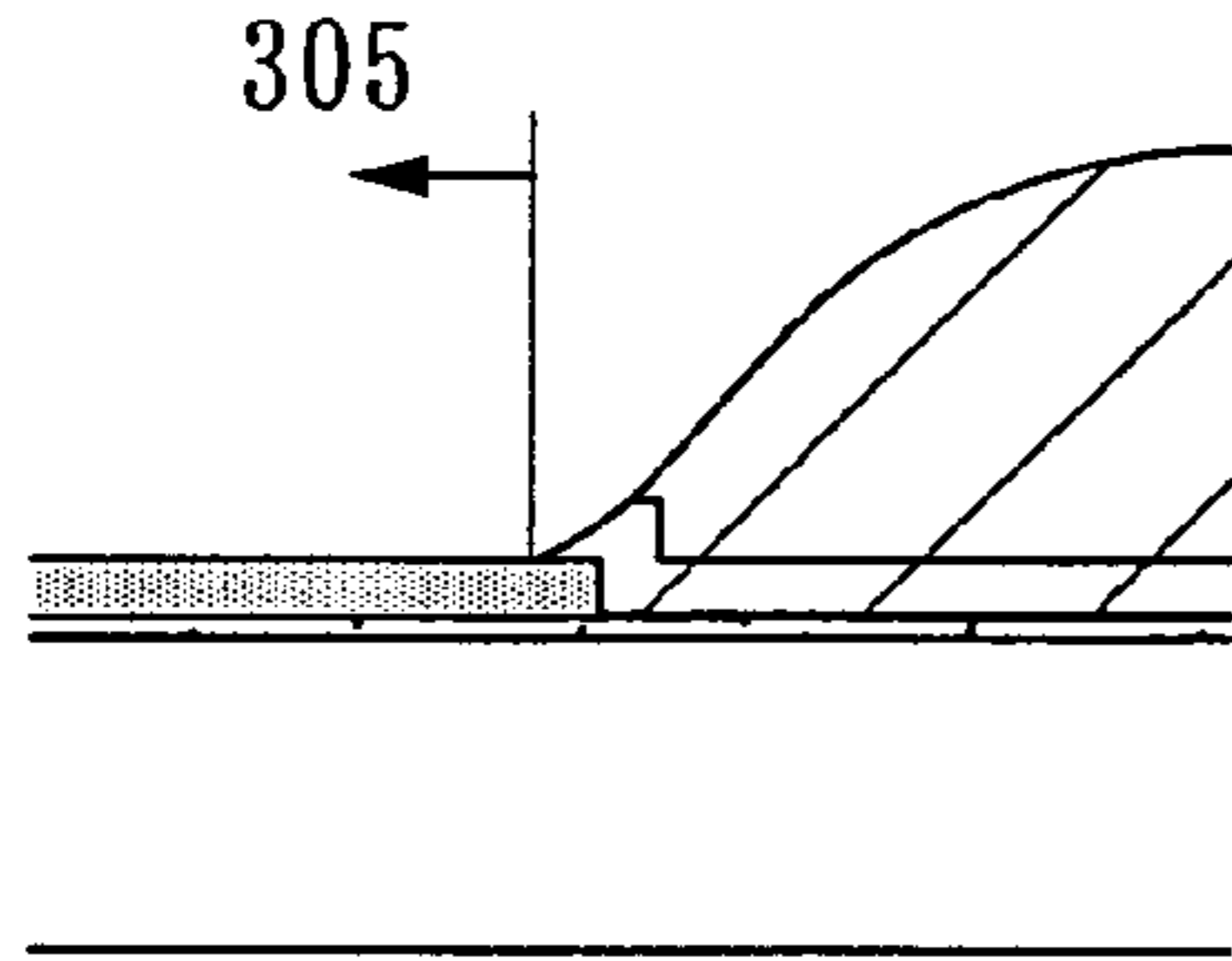

Fig. 18G

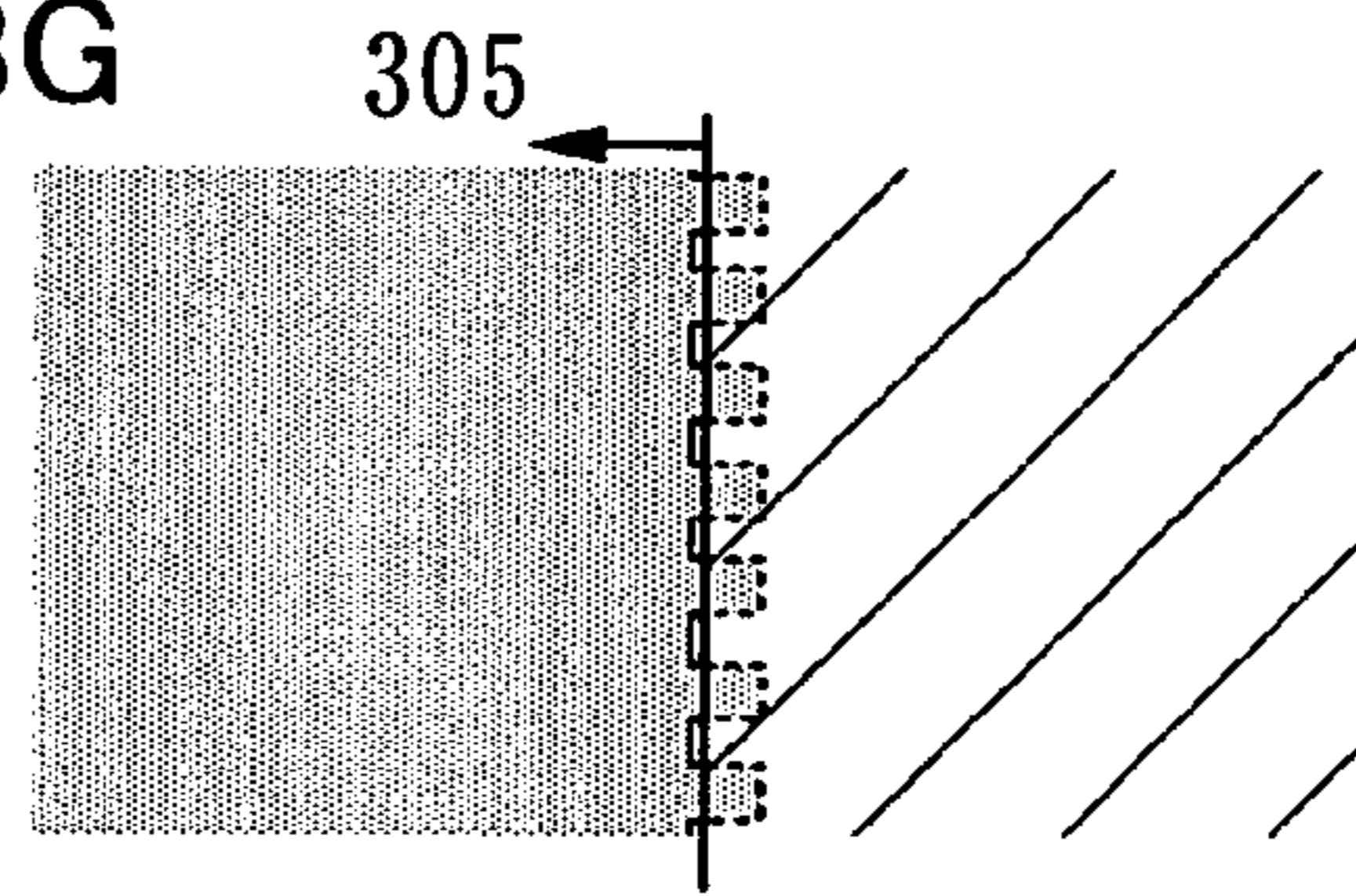

Fig. 18C

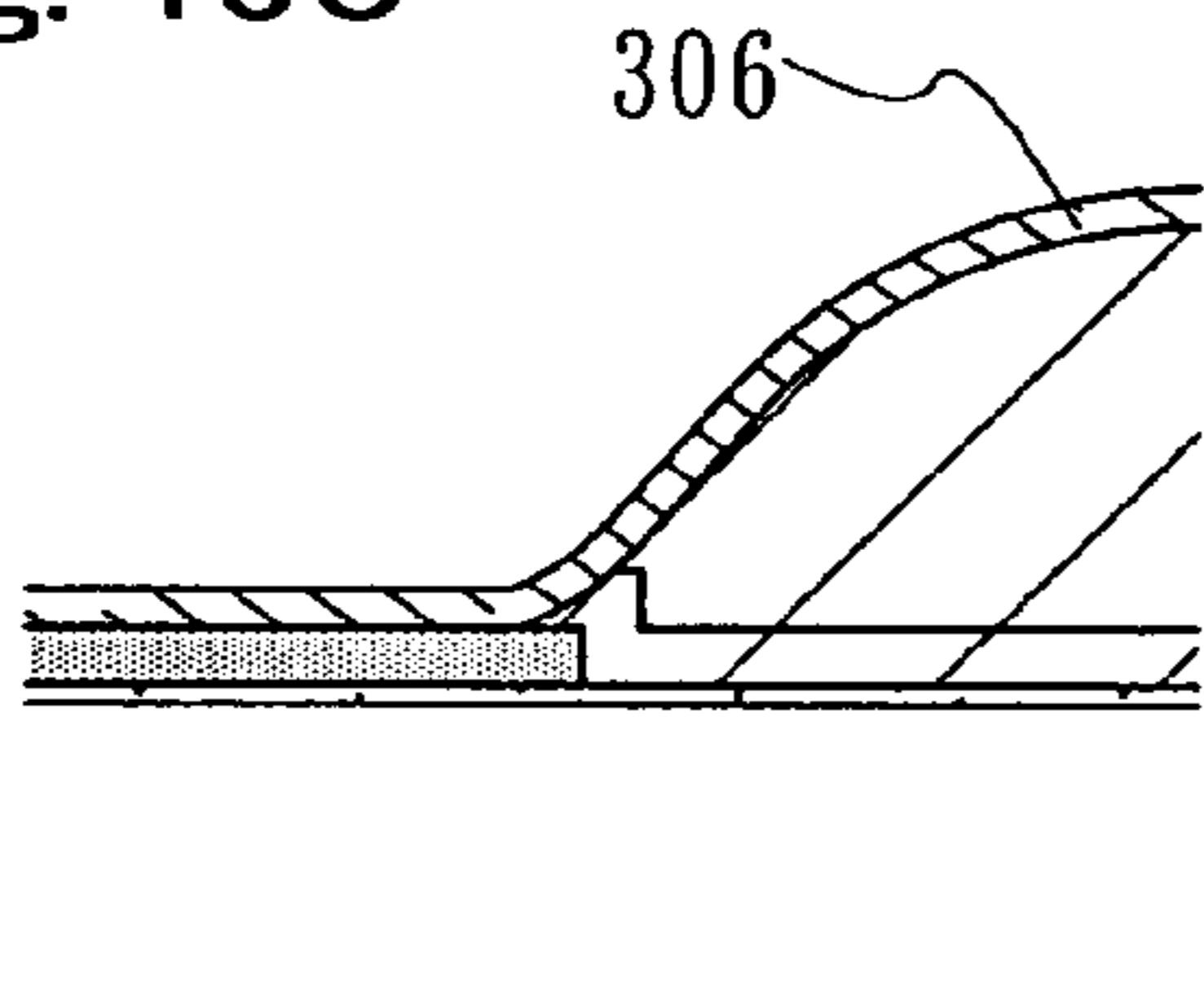

Fig. 18H

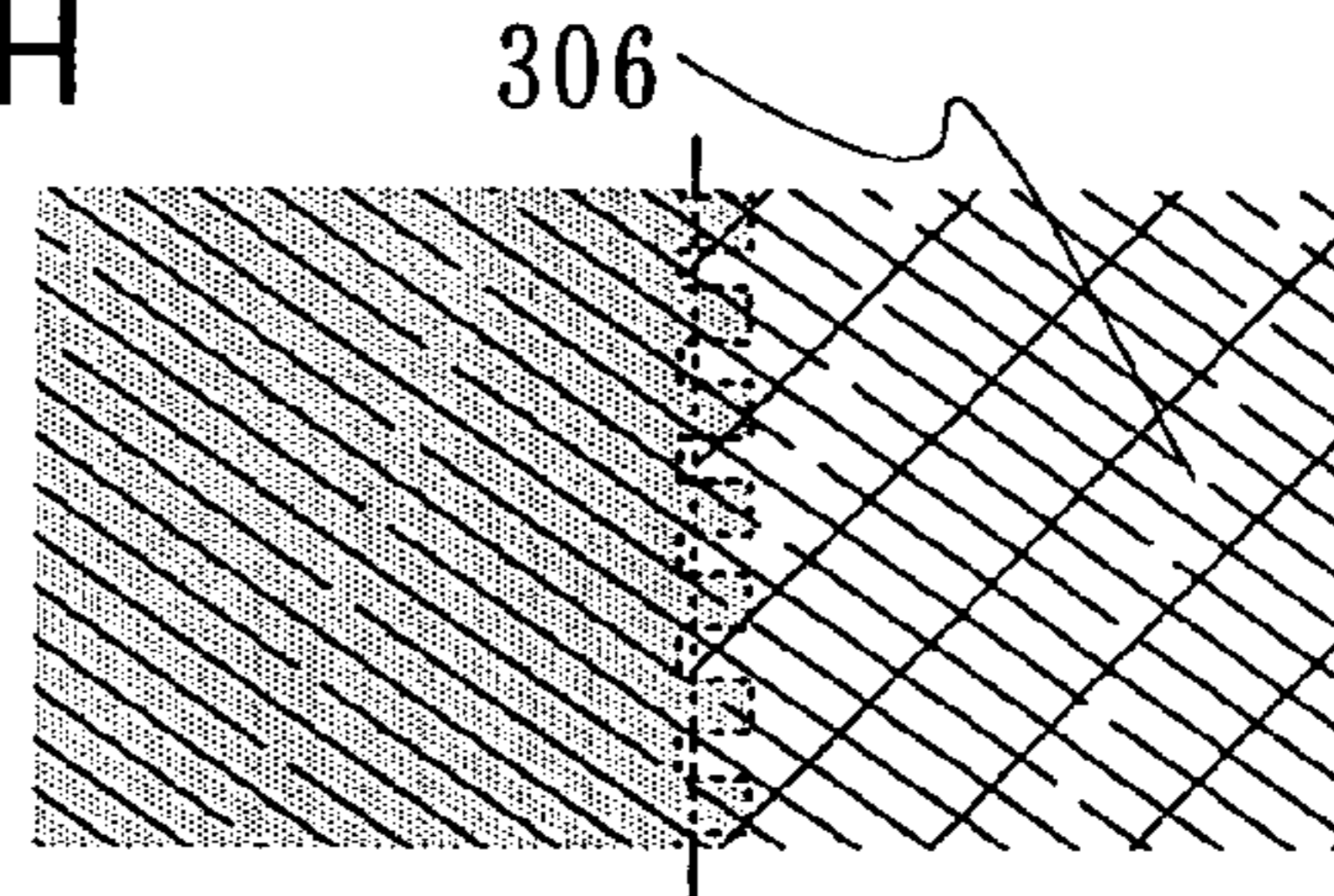

Fig. 18D

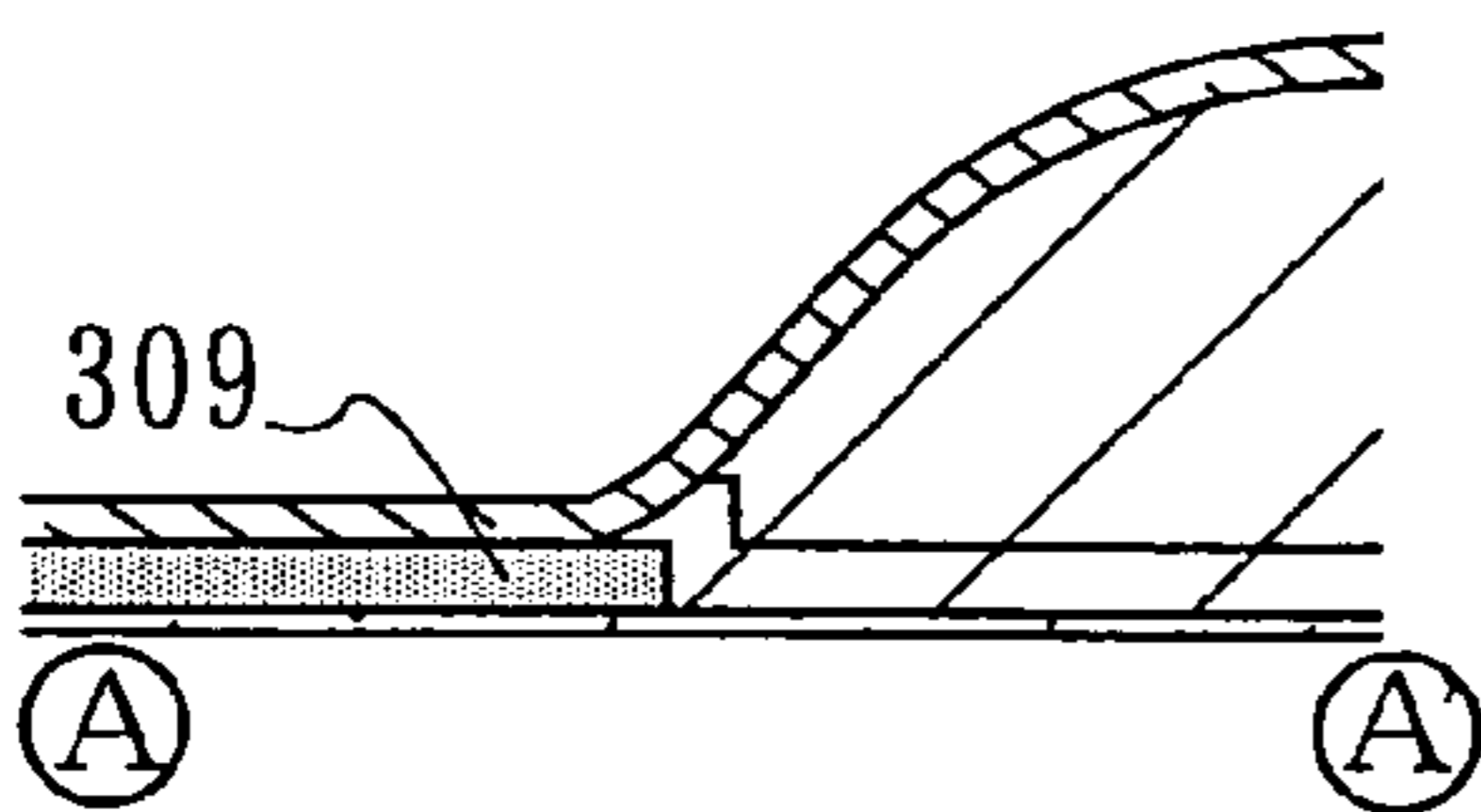

Fig. 18I

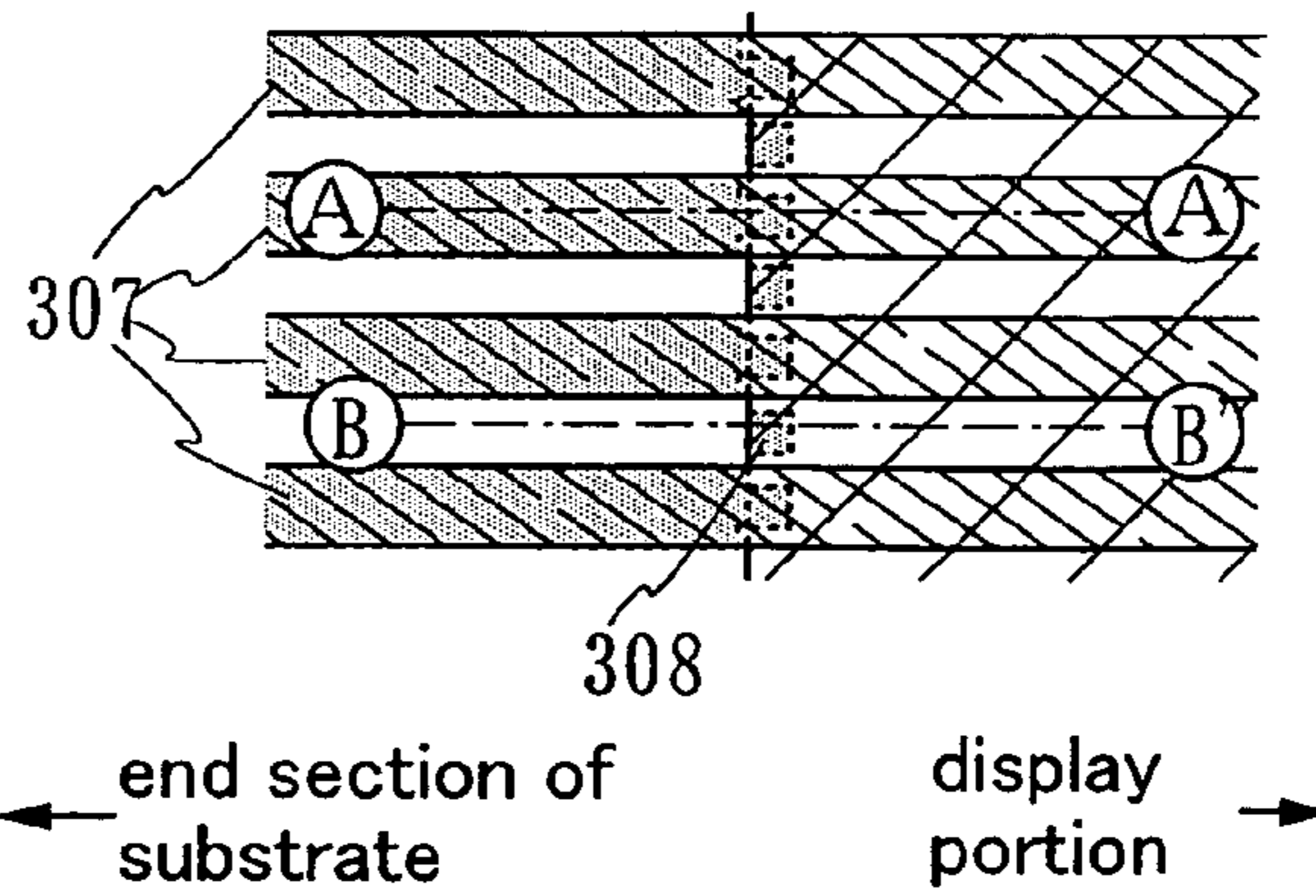
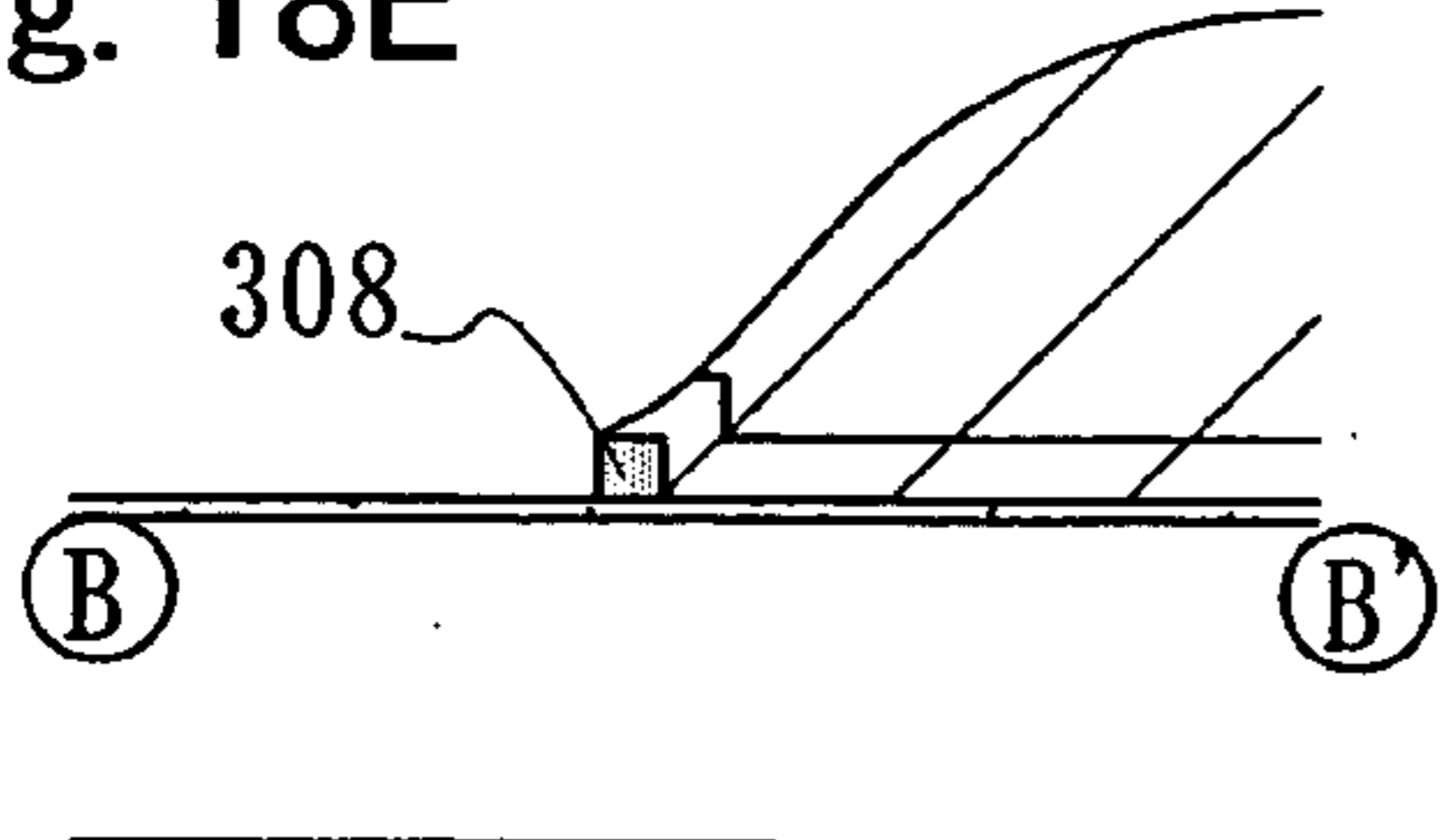

Fig. 18E



← end section of substrate display portion →

Fig. 19A

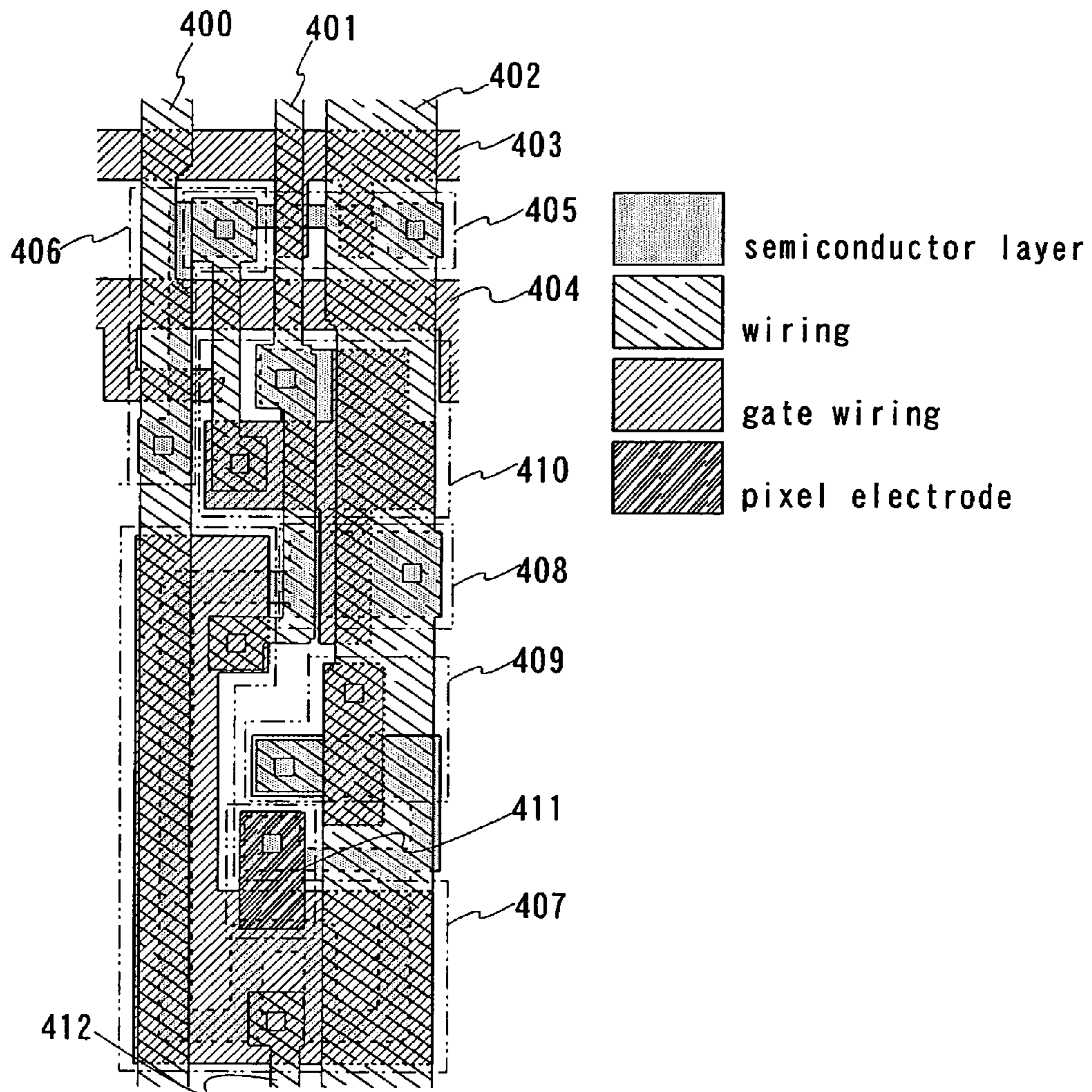

Fig. 19B

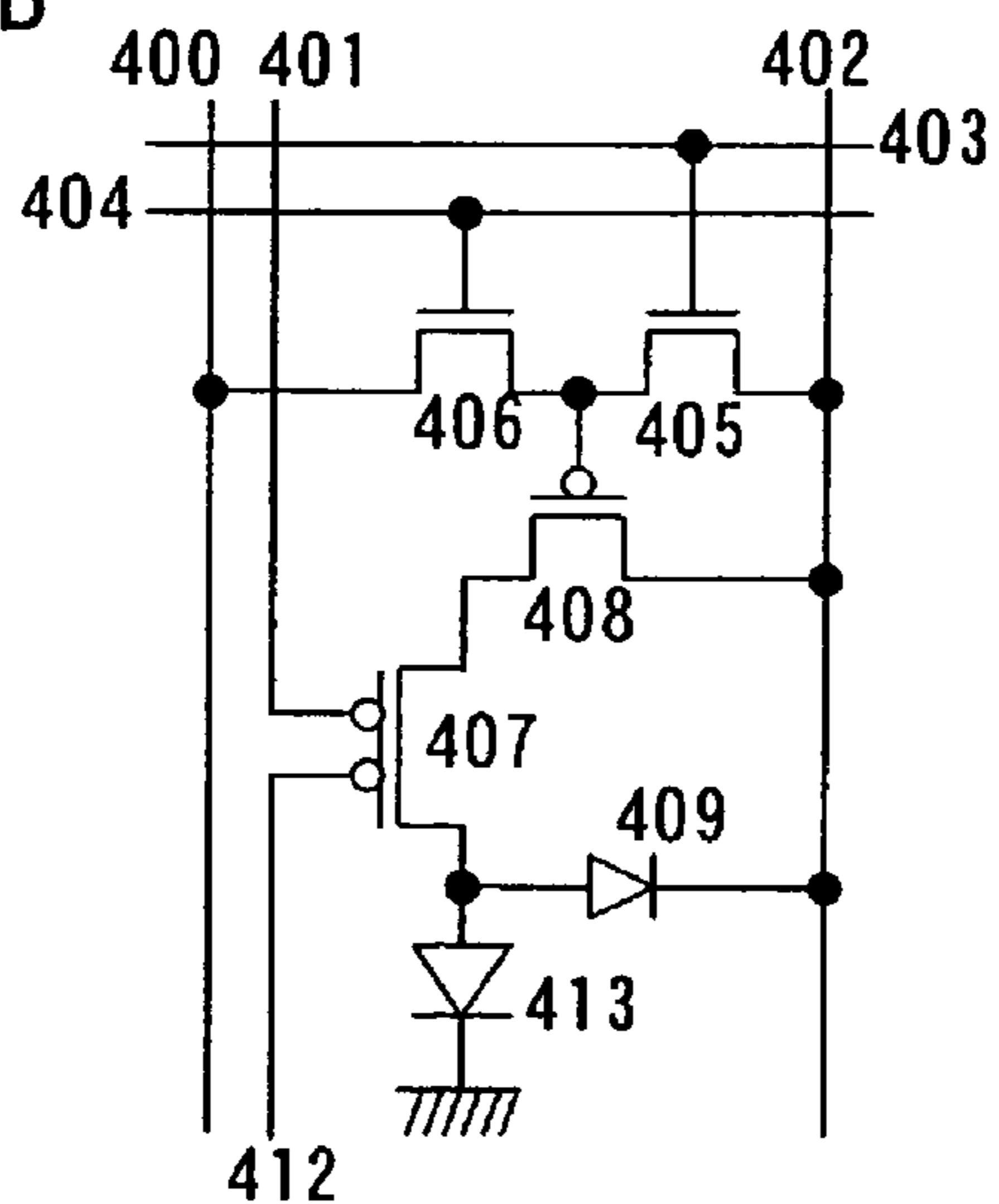

Fig. 20

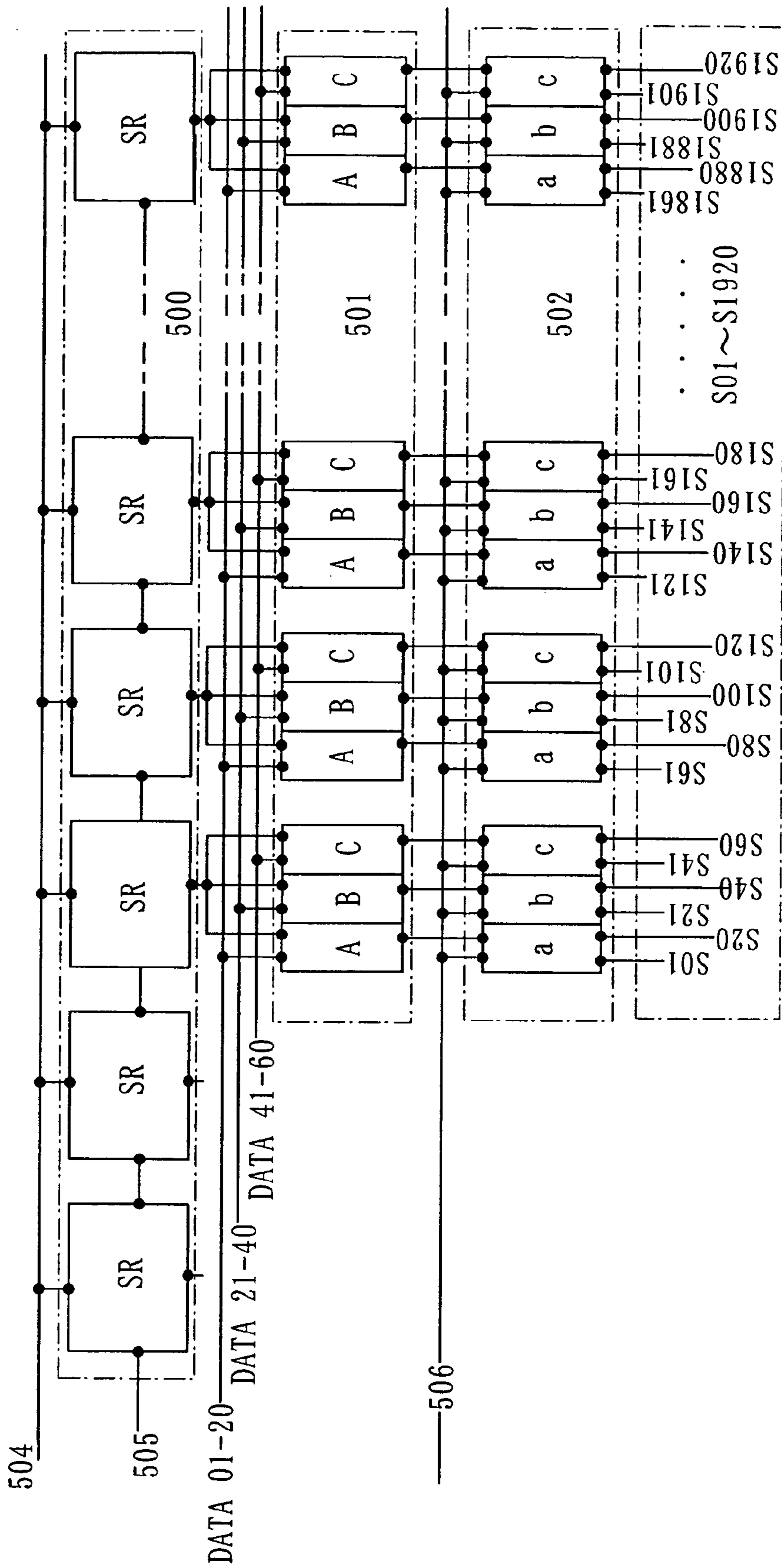

Fig. 21A

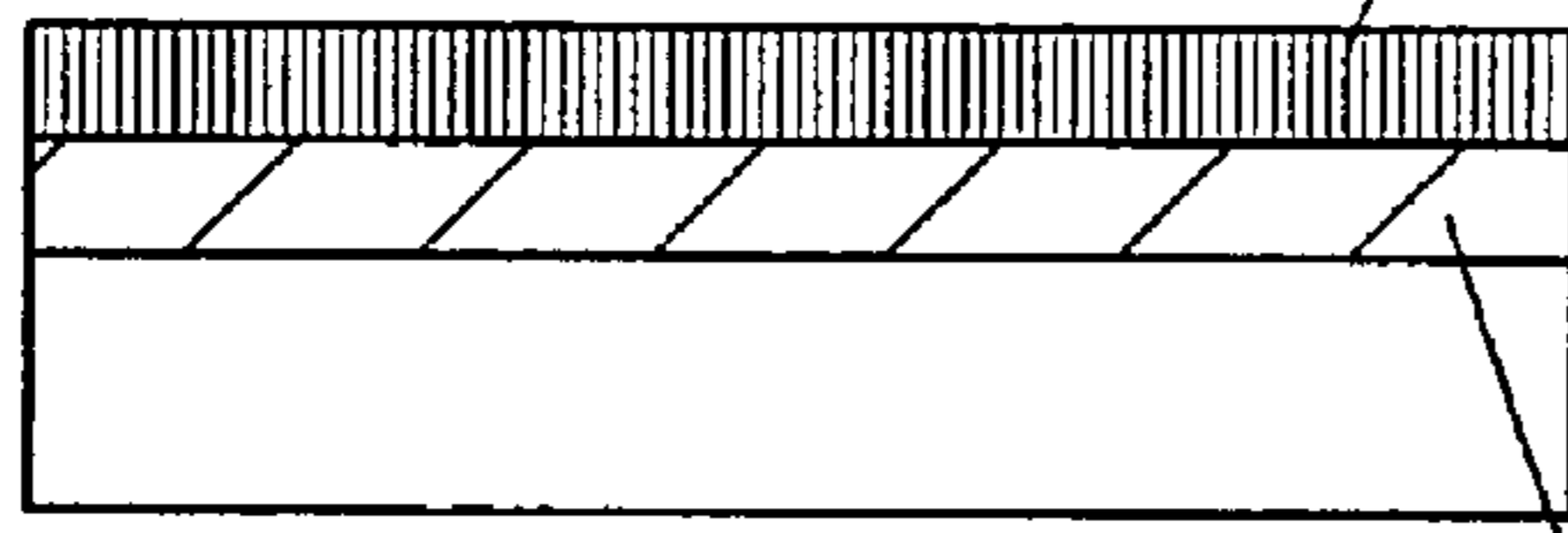

Fig. 21F

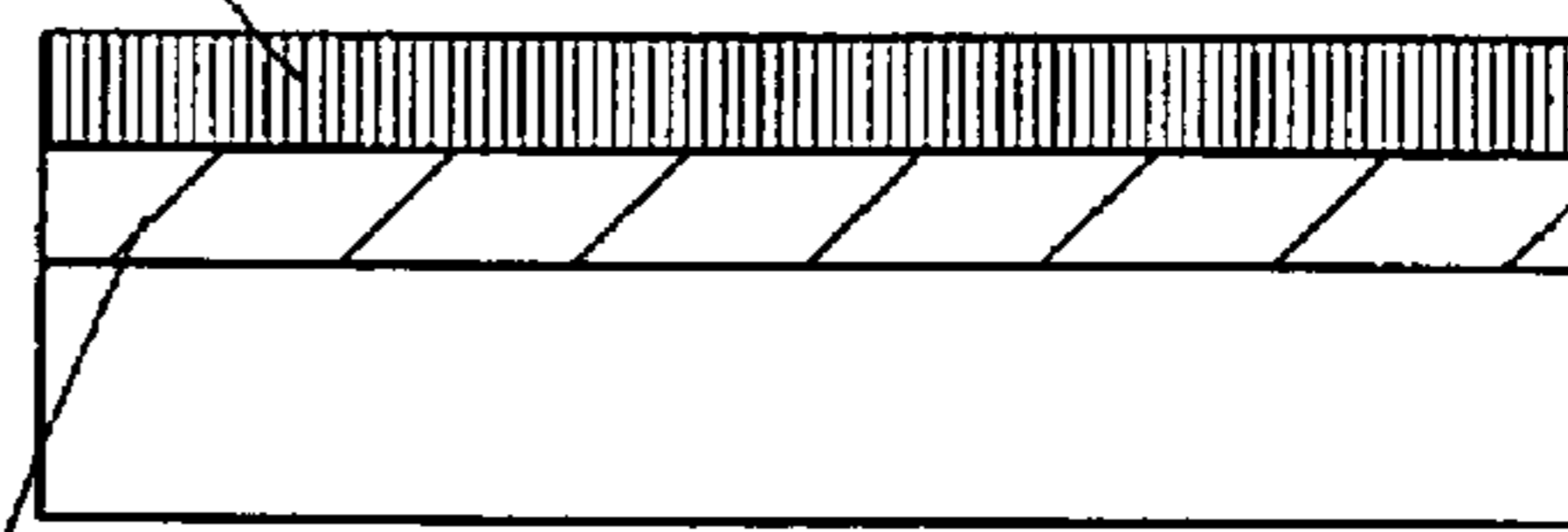

Fig. 21B

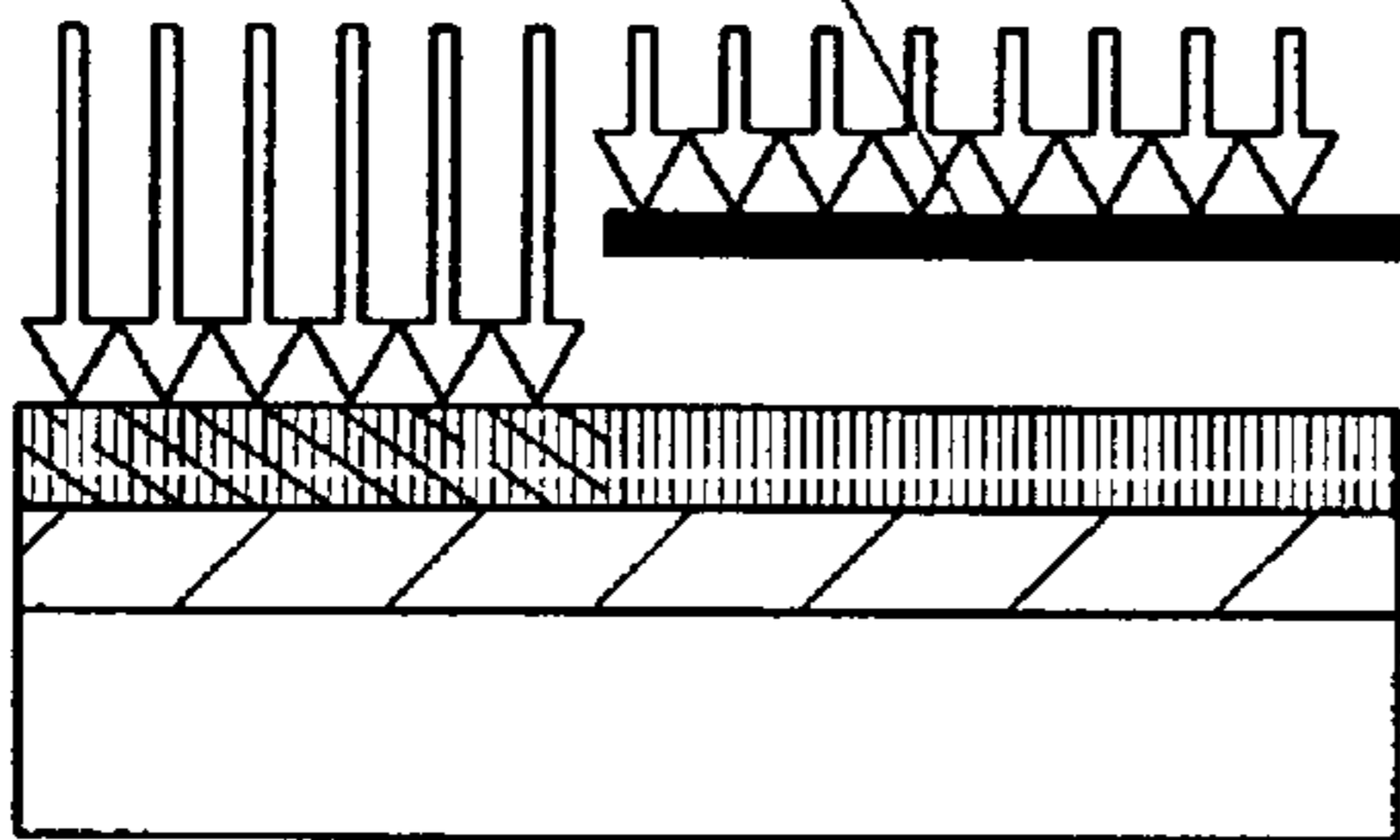

Fig. 21G

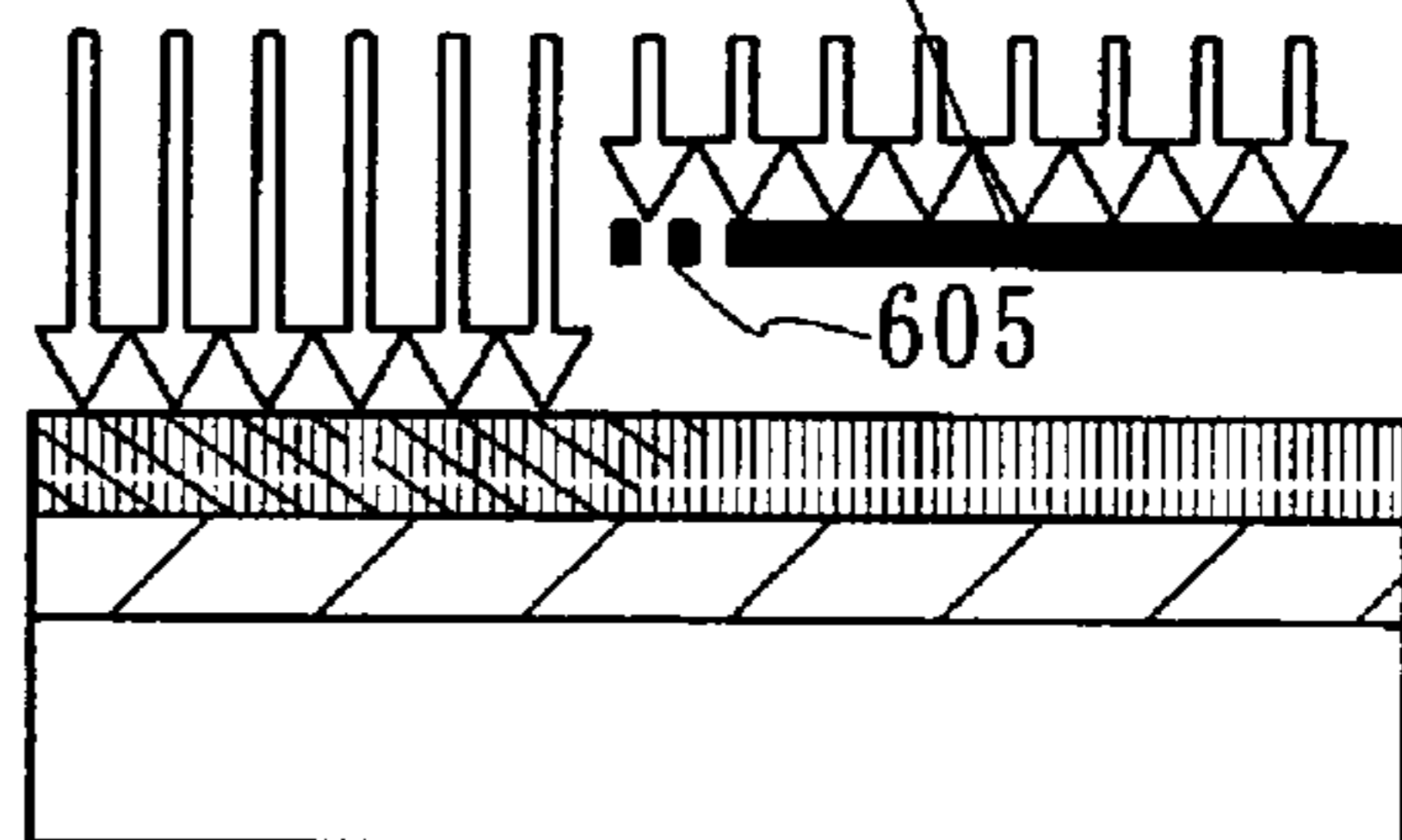

Fig. 21C

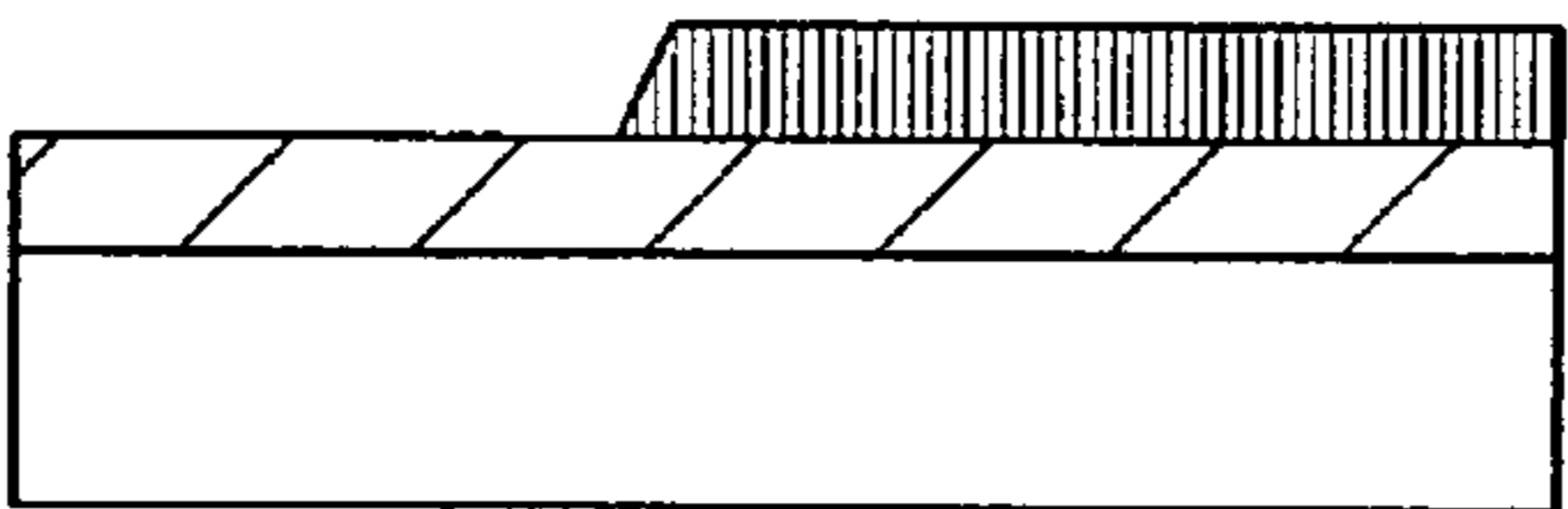

Fig. 21H

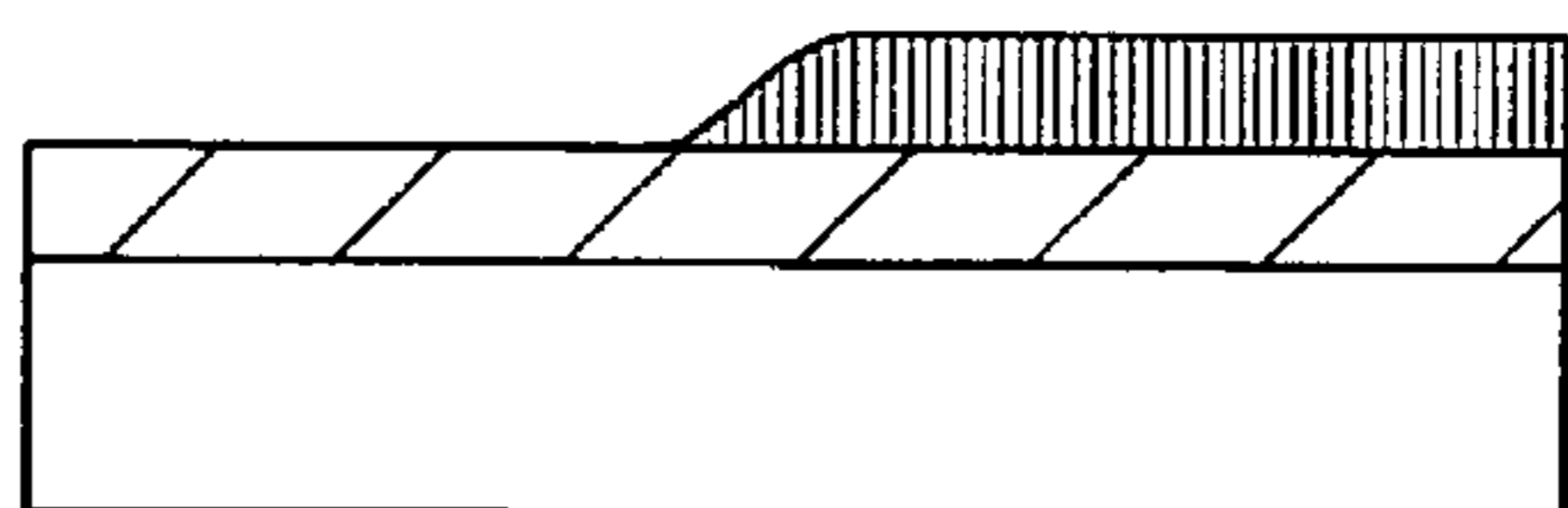

Fig. 21D

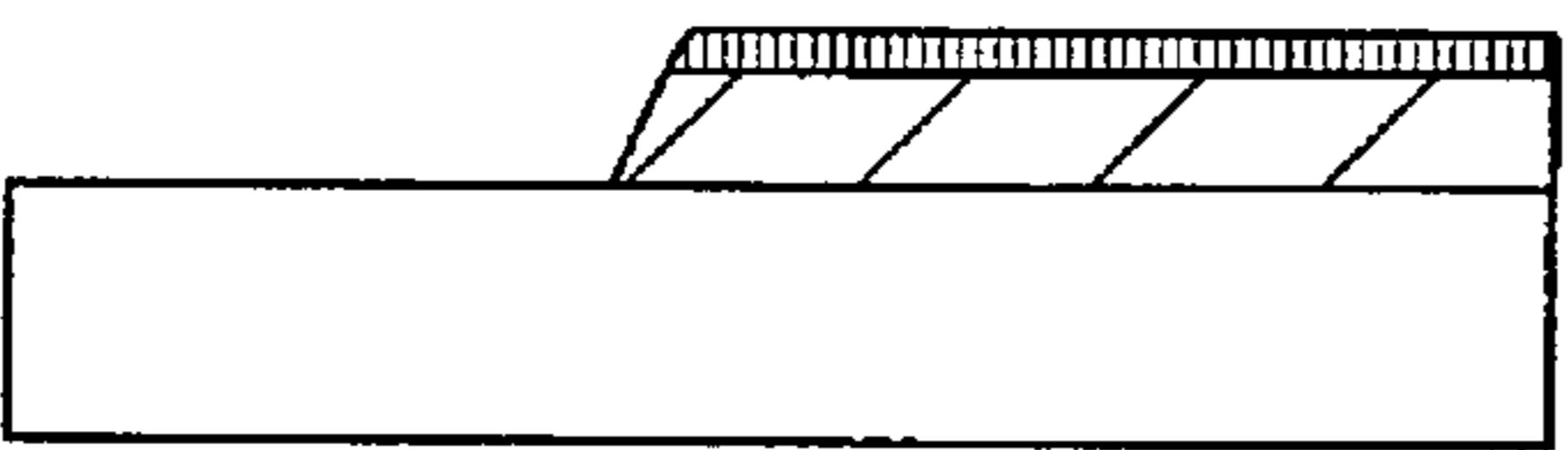

Fig. 21I

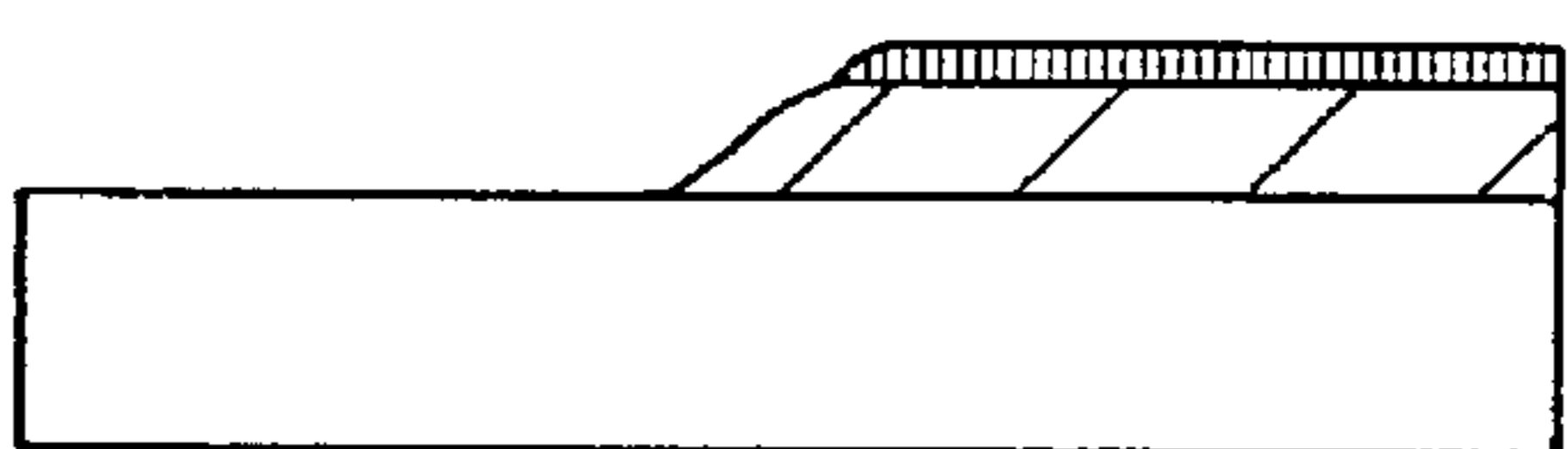

Fig. 21E

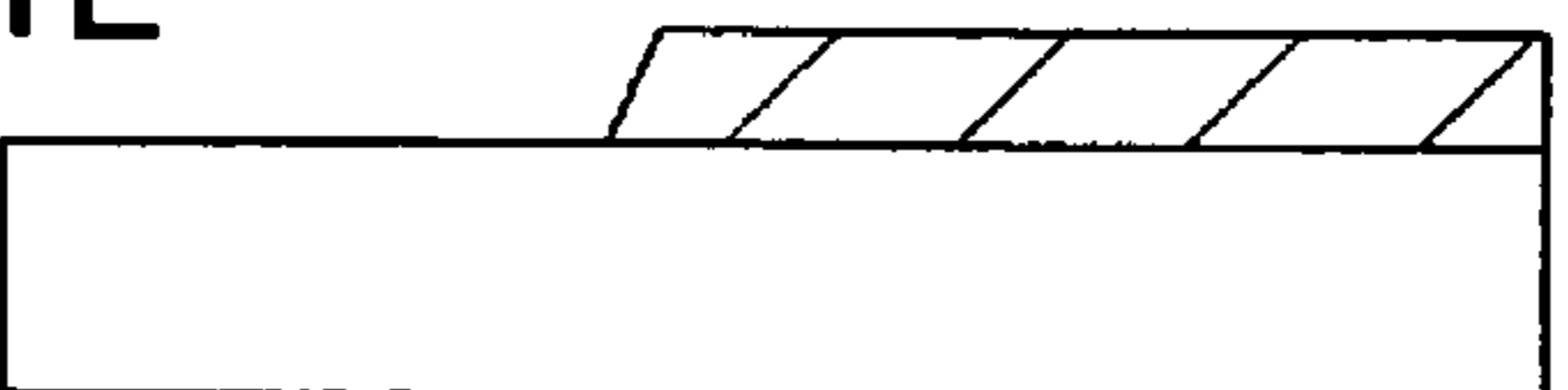

Fig. 21J

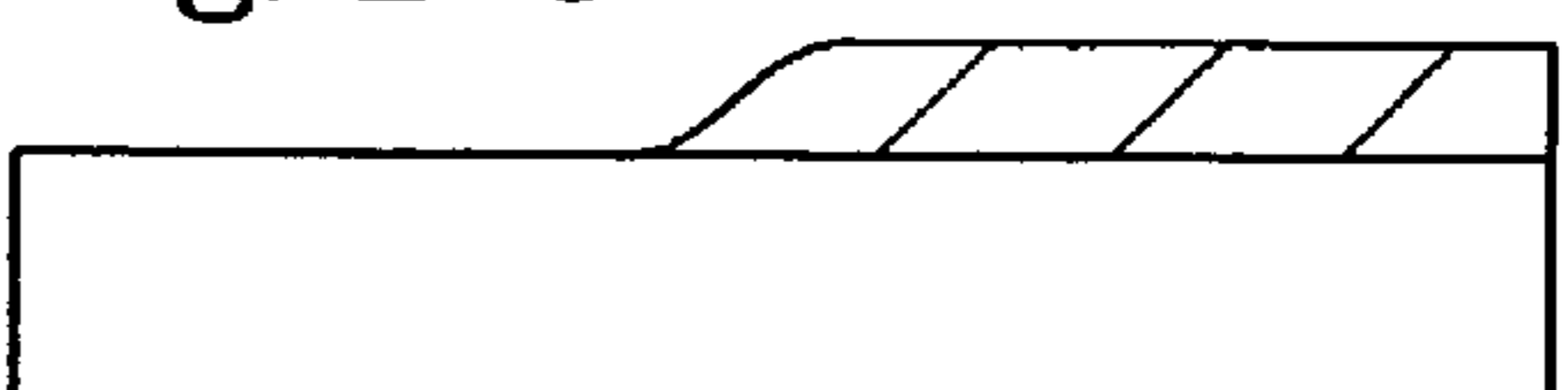

Fig. 22A

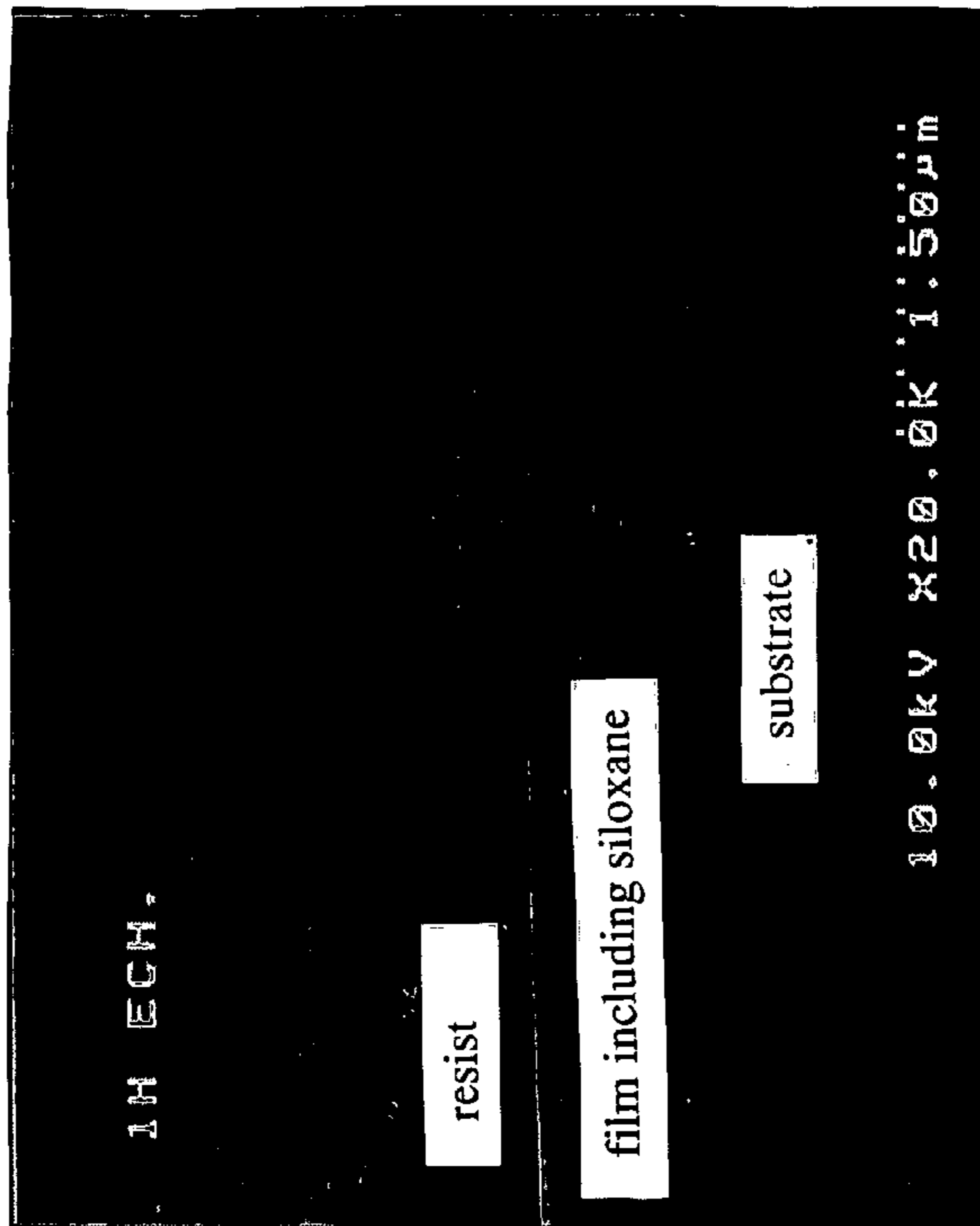

Fig. 22C

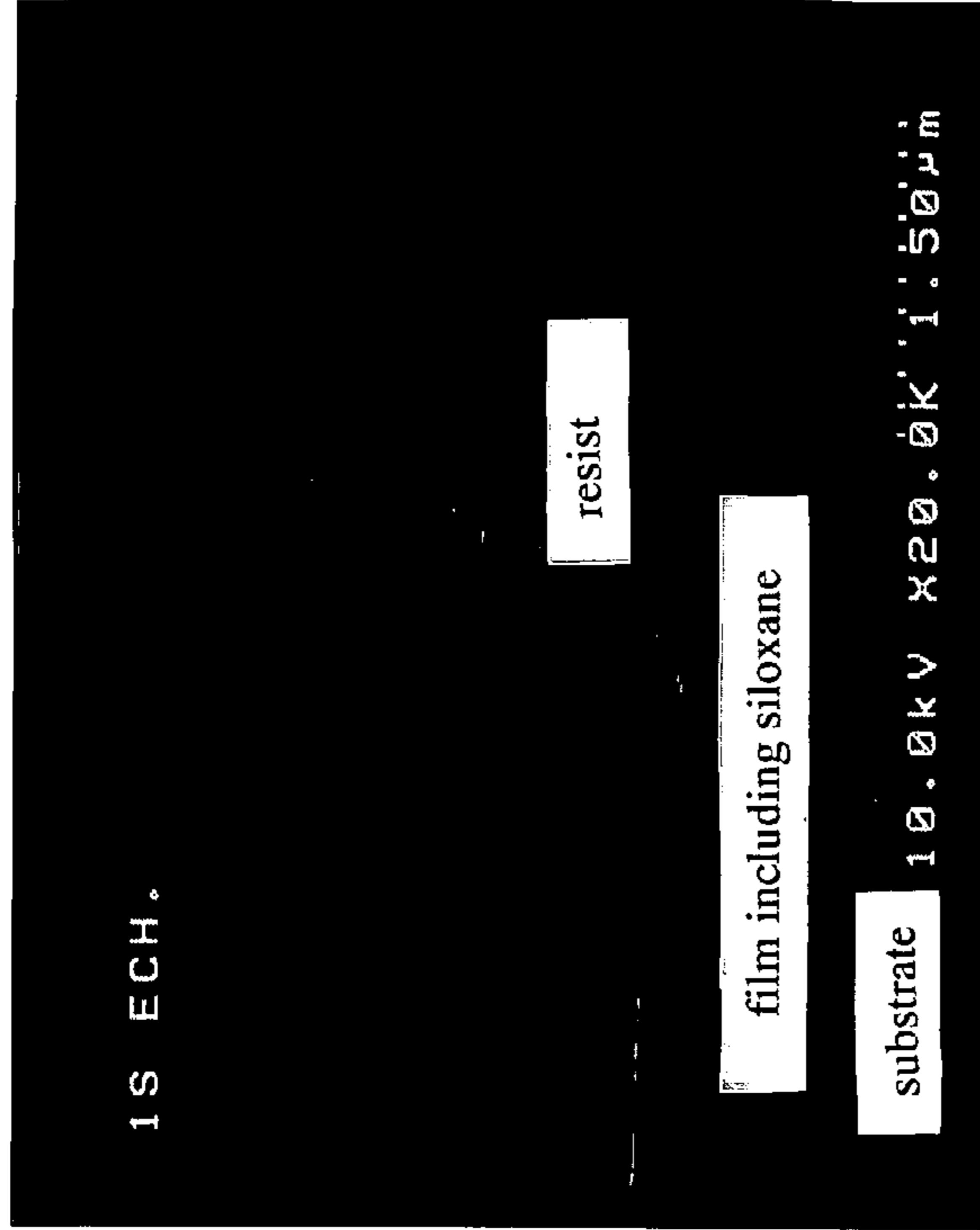

Fig. 22B

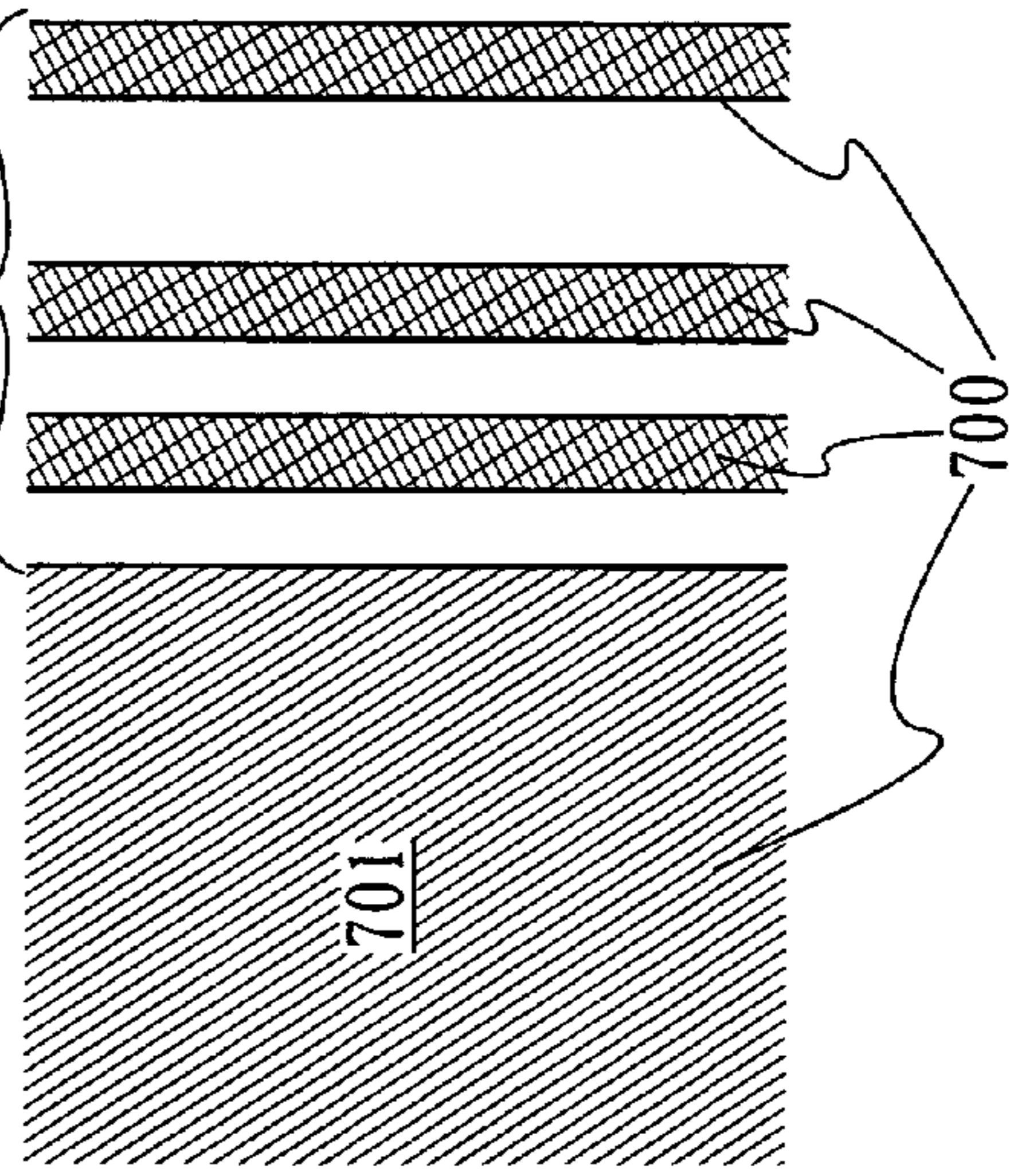

Fig. 22D

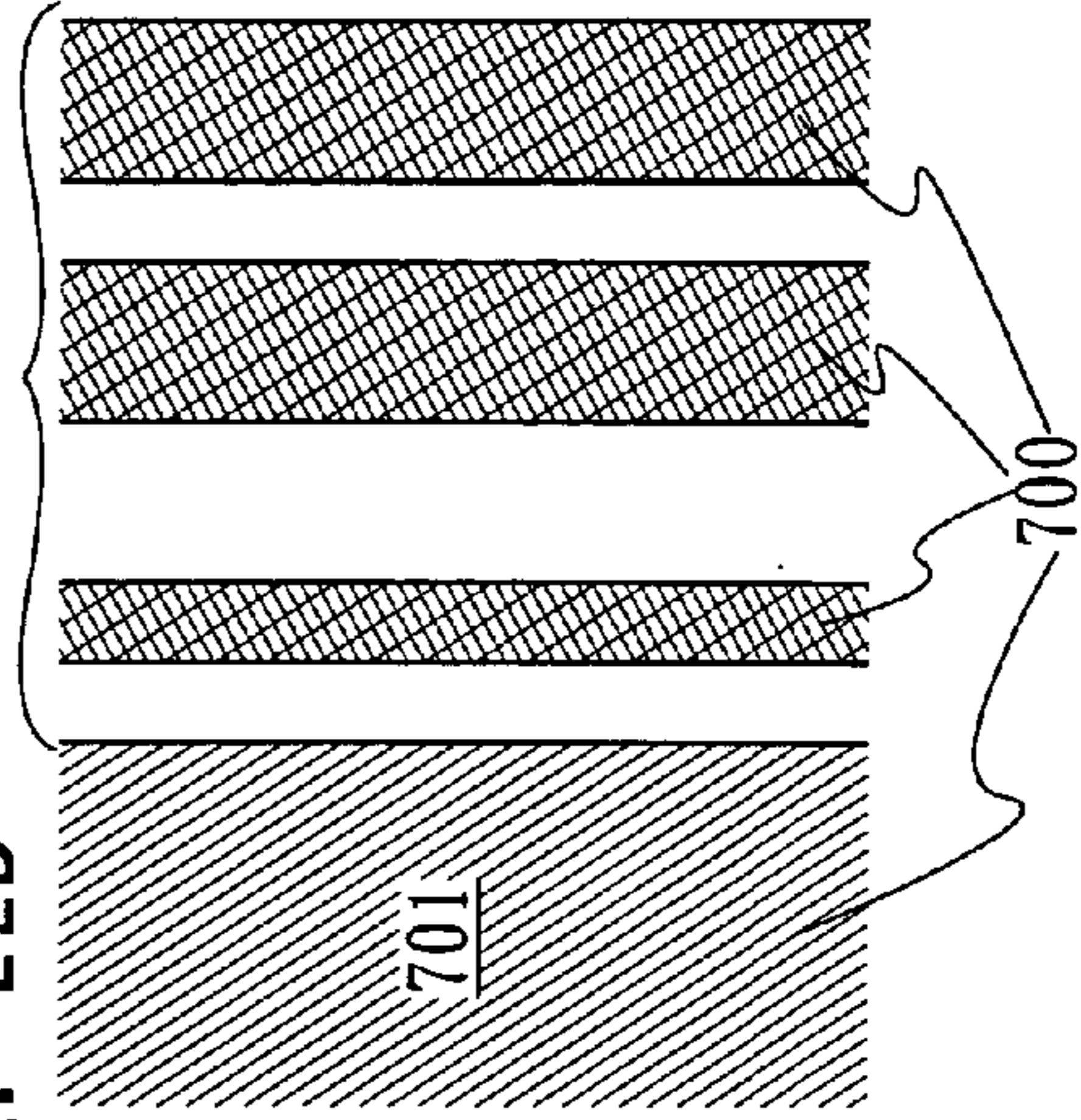

Fig. 23A

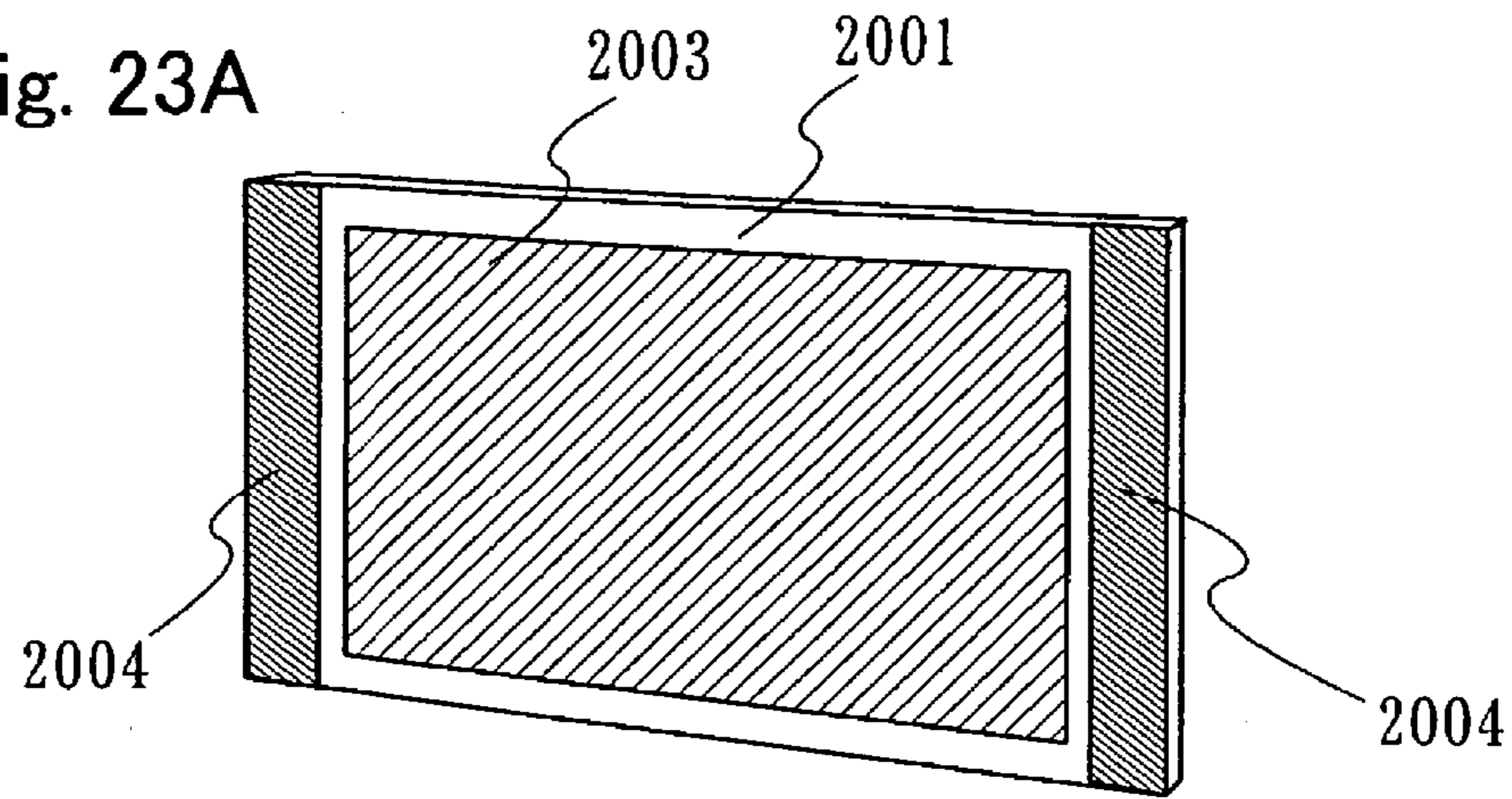

Fig. 23B

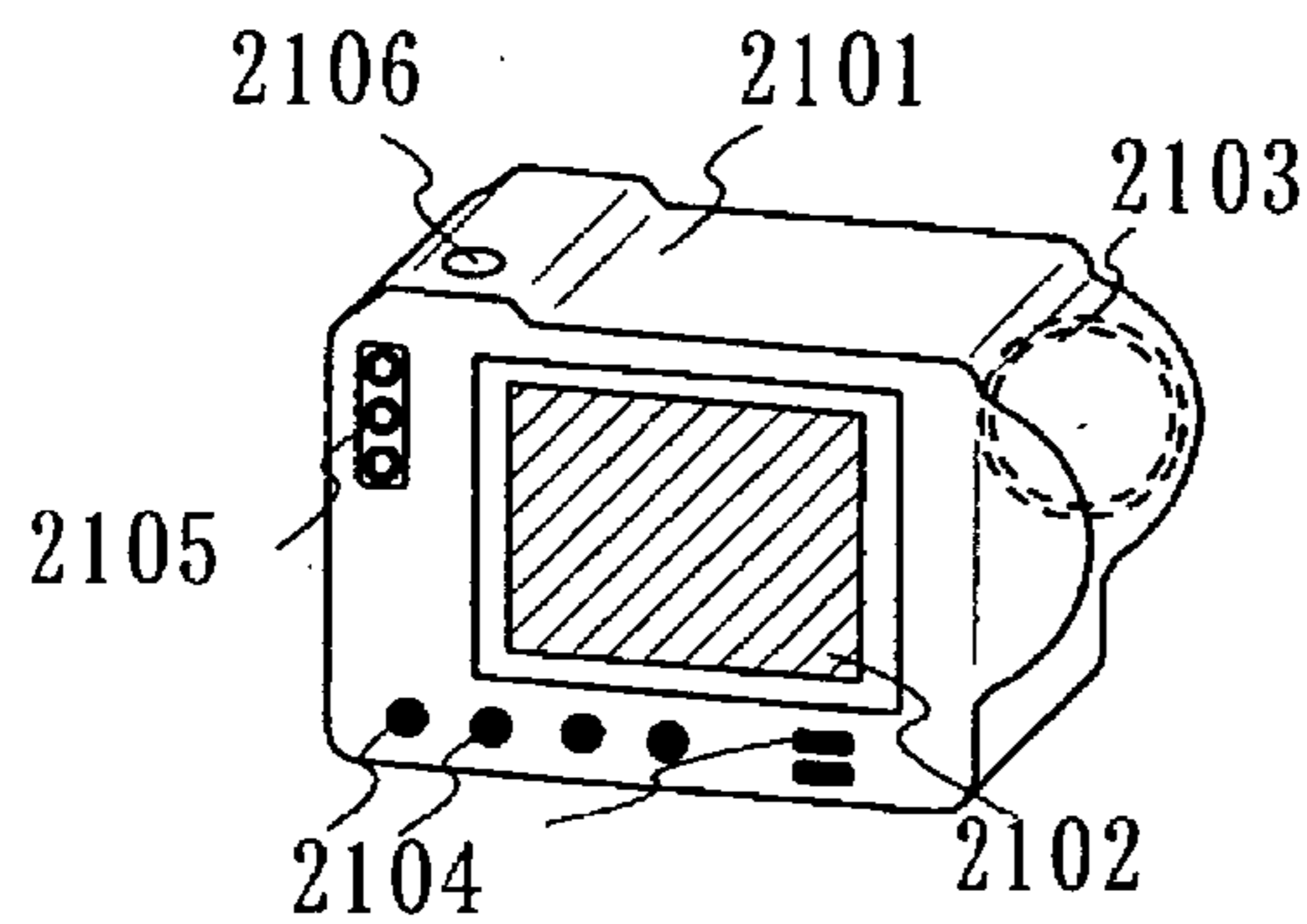

Fig. 23C

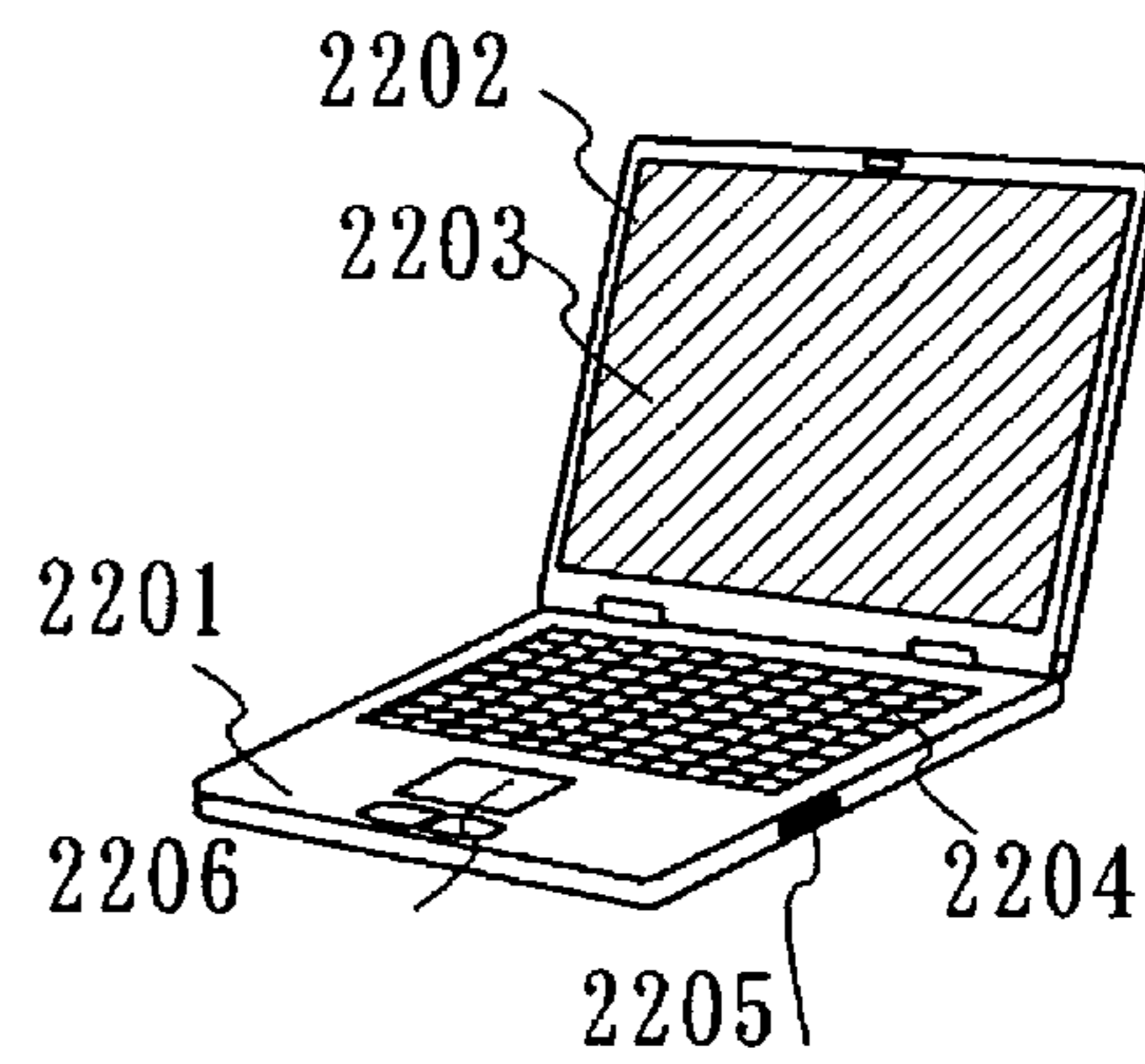

Fig. 23D

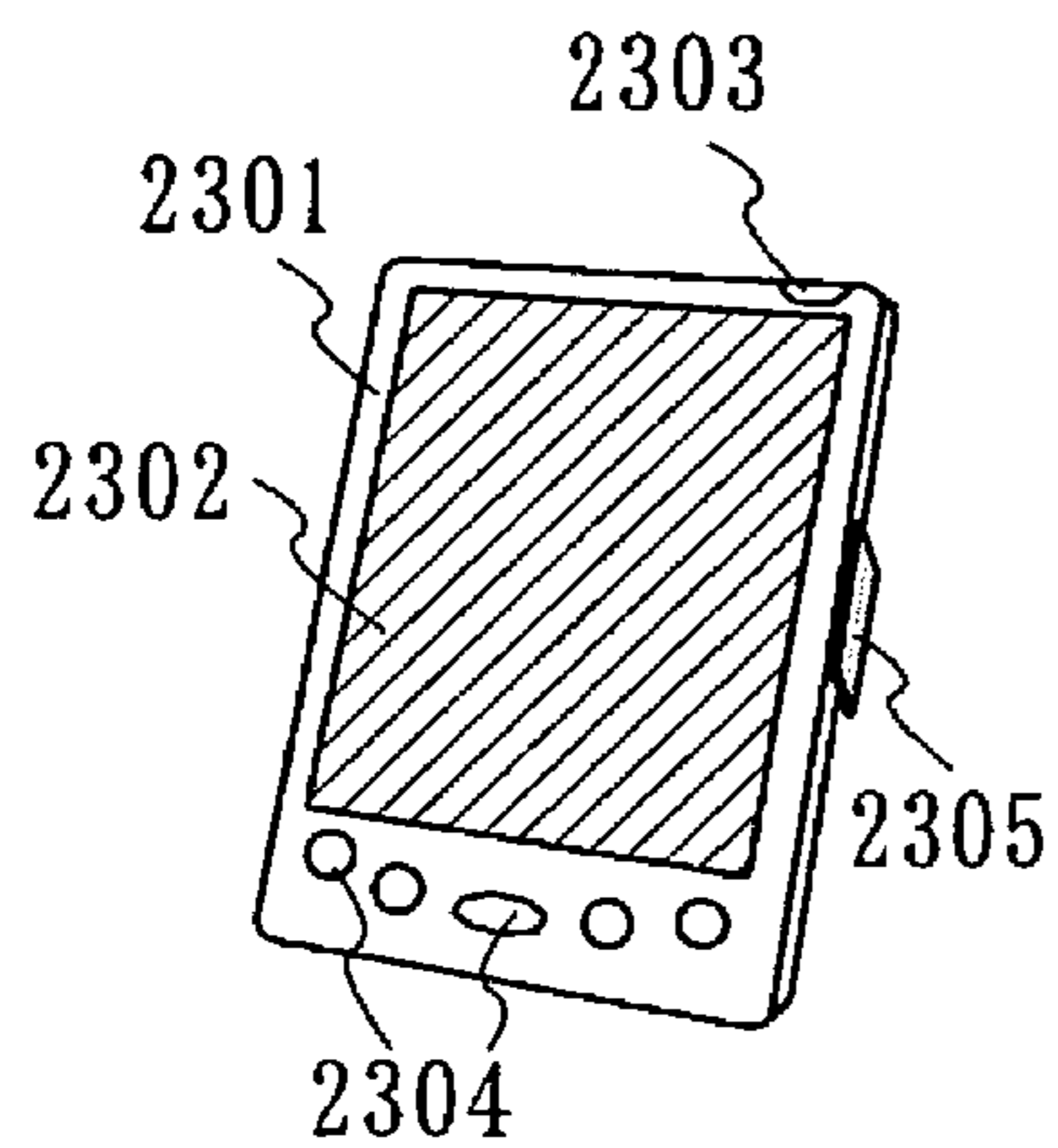
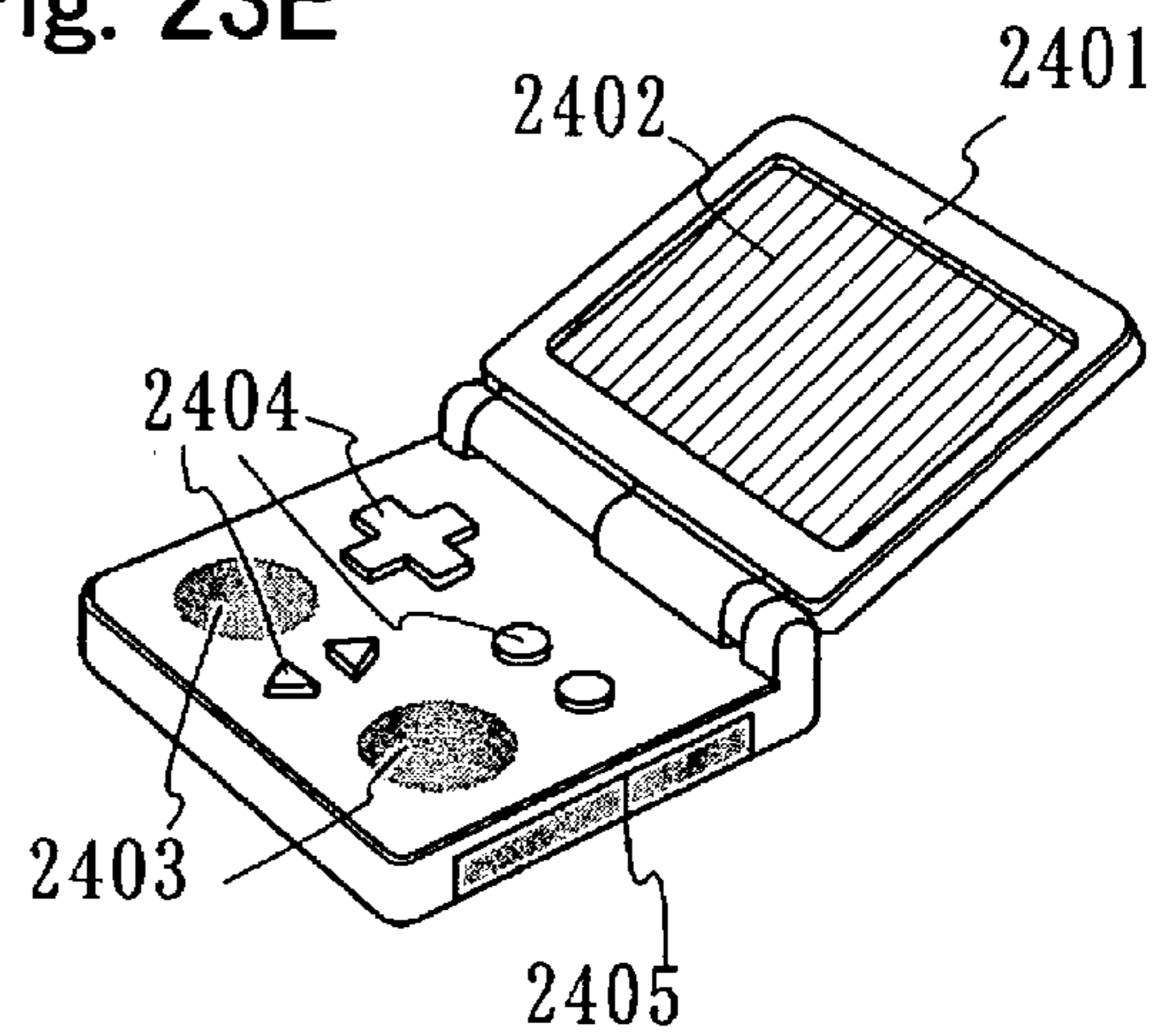

Fig. 23E



DISPLAY DEVICE AND METHOD FOR MANUFACTURING THE SAME

BACKGROUND OF THE INVENTION

1. Field of the Invention

The present invention relates to a display device formed using an element (light emitting element) which has a light-emitting material interposed between electrodes and emits light by applying current between the electrodes, and particularly, to a sealing structure of a light emitting element in such a display device.

2. Description of the Related Art

In recent years, a thin and lightweight display using a light emitting element has actively been developed. The light emitting element is formed by interposing a material which emits light by applying current between a pair of electrodes. A light source such as back light is not required since it itself emits light unlike in the case of liquid crystal, and the element itself is very thin. Therefore, it is extremely advantageous to form a thin and lightweight display.

Although the light emitting material of the light emitting element includes an organic one and an inorganic one, a light emitting element using an organic material that is driven with low voltage is often considered the most preferable. Drive voltage of a display having a light emitting element using an organic material is from 5 V to 10 V, and it is understood that it can be driven with very low voltage compared to an electroluminescent device using an inorganic material which requires drive voltage of from 100 V to 200 V. Drive voltage of a liquid crystal display singing the praises of low power consumption is approximately from 5 V to 15.5 V, and it is understood that the display having the light emitting element using an organic material can be driven with equal to or lower voltage than a liquid crystal display.

However, one background of not reaching a practical use yet while having such advantages is a problem of reliability. The light emitting element using an organic material often deteriorates due to moisture, and has a defect of being hard to obtain long-term reliability. The light emitting element which is deteriorated due to moisture causes decrease in luminance or does not emit light. It is conceivable that this causes a dark spot (black spot) and a shrink (decrease in luminance from an edge portion of a display device) in a display device using the light emitting element.

Various countermeasures are suggested to suppress such deterioration (for example, Reference 1: Japanese Patent Laid-Open No. 9-148066, and Reference 2: Japanese Patent Laid-Open No. 13-203076).

However, sufficient reliability is not obtained yet even when these countermeasures are taken, and thus, further improvement in reliability is expected.

SUMMARY OF THE INVENTION

It is an object of the present invention to provide such a sealing structure that a material to be a deterioration factor such as water or oxygen is prevented from entering from external and sufficient reliability is obtained in a display using an organic or inorganic light emitting element.

In view of the above object, deterioration of a light emitting element is suppressed and sufficient reliability is obtained by preventing water entry from an interlayer insulating film according to the present invention. In the present invention, at least one side of substrates is light transmitting in a light emitting device having a pixel portion made up of a light emitting element interposed between the substrates.

One structure of the present invention is a light emitting device comprising a light emitting element interposed between a pair of substrates, at least one of which is light transmitting, wherein the light emitting element is formed to be in contact with one of or both a first interlayer insulating film and a second interlayer insulating film, and a peripheral portion of the first interlayer insulating film and the second interlayer insulating film comprises: a first opening which penetrates the first interlayer insulating film; a first impermeable protective film covering the first opening and the first interlayer insulating film in the first opening; and a second opening which penetrates the second interlayer insulating film.

Another structure of the present invention is a light emitting device comprising a light emitting element interposed between a pair of substrates, at least one of which is light transmitting, wherein the light emitting element is formed to be in contact with one of or both a first interlayer insulating film and a second interlayer insulating film, and a peripheral portion of the first interlayer insulating film and the second interlayer insulating film comprises: a first opening which penetrates the first interlayer insulating film; a first impermeable protective film covering the first opening and the first interlayer insulating film in the first opening; a second opening which penetrates the second interlayer insulating film; and a second impermeable protective film covering the second opening and the second interlayer insulating film in the second opening and in contact with the first impermeable protective film on a bottom face of the second opening.

Another structure of the present invention is a light emitting device comprising a light emitting element interposed between a pair of substrates, at least one of which is light transmitting, wherein the light emitting element is formed to be in contact with one of or both a first interlayer insulating film and a second interlayer insulating film, a peripheral portion of the first interlayer insulating film and the second interlayer insulating film comprises: a first opening which penetrates the first interlayer insulating film; a first impermeable protective film covering the first opening and the first interlayer insulating film in the first opening; a second opening which penetrates the second interlayer insulating film; and a second impermeable protective film covering the second opening and the second interlayer insulating film in the second opening and in contact with the first impermeable protective film on a bottom face of the second opening, and the pair of substrates is fixed to each other with an impermeable composition in a region provided with the first opening and the second opening or in an outer side of the region.

Another structure of the present invention is a light emitting device according to the above structure, wherein the second impermeable protective film comprises the same material as an anode or cathode of the light emitting element.

Another structure of the present invention is a light emitting device according to the above structure, wherein the light emitting element is provided with a pixel portion connected to a thin film transistor.

Another structure of the present invention is a light emitting device according to the above structure, wherein the first impermeable protective film is made of the same material as a source electrode and a drain electrode of the thin film transistor.

Another structure of the present invention is a light emitting device according to the above structure, wherein a semiconductor film is formed in a lower portion of the first opening.

Another structure of the present invention is a light emitting device according to the above structure, wherein a metal film is formed in a lower portion of the first opening.

Another structure of the present invention is a light emitting device according to the above structure, wherein a semiconductor film is formed in a lower portion of the first opening, and the semiconductor film is made of the same material as an active layer of the thin film transistor.

Another structure of the present invention is a light emitting device according to the above structure, wherein a metal film is formed in a lower portion of the first opening, and the metal film is made of the same material as a gate electrode of the thin film transistor.

Another structure of the present invention is a light emitting device according to the above structure, wherein at least a portion of a bottom face of the first opening and a portion of the bottom face of the second opening are formed in the same position on a face of the substrate.

Another structure of the present invention is a light emitting device according to the above structure, wherein a bottom face of the first opening and the bottom face of the second opening are formed in a different position on a face of the substrate.

Another structure of the present invention is a light emitting device according to the above structure, wherein a plurality of the first openings and the second openings is formed.

Another structure of the present invention is a light emitting device according to the above structure, wherein at least one layer of the first interlayer insulating film and the second interlayer insulating film is made of an organic material.

Another structure of the present invention is a light emitting device according to the above structure, wherein at least one layer of the first interlayer insulating film and the second interlayer insulating film is made of an inorganic material.

Another structure of the present invention is a light emitting device according to the above structure, wherein at least one layer of the first interlayer insulating film and the second interlayer insulating film is made of a siloxane film.

Another structure of the present invention is a light emitting device according to the above structure, wherein the organic material is acrylic or polyimide.

Another structure of the present invention is a light emitting device according to the above structure, wherein the first impermeable protective film or the second impermeable protective film is a silicon nitride film.

Another structure of the present invention is a light emitting device according to the above structure, wherein the first impermeable protective film and the second impermeable protective film are silicon nitride films.

Another structure of the present invention is a light emitting device comprising a light emitting element interposed between a pair of substrates, at least one of which is light transmitting, wherein the light emitting element is formed to be in contact with an interlayer insulating film, and a side edge portion of the interlayer insulating film formed inside not to reach an edge portion of the substrate is processed into a tapered shape.

Another structure of the present invention is a light emitting device comprising a light emitting element interposed between a pair of substrates, at least one of which is light transmitting, wherein the light emitting element is formed to be in contact with an interlayer insulating film, a side edge portion of the interlayer insulating film formed inside not to reach an edge portion of the substrate is processed into a tapered shape, and an impermeable protective film is formed in the side edge portion of the interlayer insulating film.

Another structure of the present invention is a light emitting device comprising a light emitting element interposed between a pair of substrates, at least one of which is light transmitting, wherein the light emitting element is formed to be in contact with an interlayer insulating film, a side edge portion of the interlayer insulating film formed inside not to reach an edge portion of the substrate is processed into a tapered shape, an impermeable protective film is formed in the side edge portion of the interlayer insulating film, and the pair of substrates is fixed to each other with an impermeable composition in a region of the side edge portion of the interlayer insulating film or in an outer side of the region.

Another structure of the present invention is a light emitting device according to the above structure, wherein the light emitting element is provided with a pixel portion connected to a thin film transistor.

Another structure of the present invention is a light emitting device according to the above structure, wherein a semiconductor film is formed from a bottom portion of the interlayer insulating film to the edge portion of the substrate.

Another structure of the present invention is a light emitting device according to the above structure, wherein a metal film is formed from a lower portion of the interlayer insulating film to the edge portion of the substrate.

Another structure of the present invention is a light emitting device according to the above structure, wherein a semiconductor film is formed from a lower portion of the interlayer insulating film to the edge portion of the substrate, and the semiconductor film is made of the same material as an active layer of the thin film transistor.

Another structure of the present invention is a light emitting device according to the above structure, wherein a metal film is formed from a lower portion of the interlayer insulating film to the edge portion of the substrate, and the metal film is made of the same material as a gate electrode of the thin film transistor.

Another structure of the present invention is a light emitting device according to the above structure, wherein the interlayer insulating film is made of an organic material.

Another structure of the present invention is a light emitting device according to the above structure, wherein the interlayer insulating film is made of an inorganic material.

Another structure of the present invention is a light emitting device according to the above structure, wherein the interlayer insulating film is made of a siloxane film.

Another structure of the present invention is a light emitting device according to the above structure, wherein the organic material is acrylic or polyimide.

Another structure of the present invention is a light emitting device according to the above structure, wherein the impermeable protective film is a silicon nitride film.

Another structure of the present invention is a light emitting device comprising: a pixel portion made up of a light emitting element interposed between a pair of substrates, at least one of which is light transmitting; an external connection portion taking in a signal from external; and a plurality of wirings connecting the pixel portion and the external connection portion, wherein the pair of substrates is fixed to each other with an impermeable composition between the pixel portion and the external connection portion, the light emitting element is formed to be in contact with an interlayer insulating film, a part of the interlayer insulating film is located between adjacent wirings in the plurality of wirings, and the wiring is thickly provided with a plurality of bends in a lower portion of or inside a portion in which the substrates are fixed to each other with the impermeable composition.

According to the above structures, deterioration of a light emitting element in an electroluminescent device can be suppressed. In addition, reliability can drastically be improved.

These and other objects, features, and advantages of the present invention will become more apparent upon reading of the following detailed description along with the accompanied drawings.

BRIEF DESCRIPTION OF THE DRAWINGS

FIGS. 1A to 1C show Embodiment Mode 1.
 FIGS. 2A and 2B show a conventional structure.
 FIG. 3 is a top view of an electroluminescent device.
 FIGS. 4A and 4B show variation of Embodiment Mode 1.
 FIGS. 5A and 5B show Embodiment Mode 2.
 FIGS. 6A to 6C show Embodiment Mode 3.
 FIGS. 7A and 7B show Embodiment Mode 3.
 FIGS. 8A to 8C show a conventional structure.
 FIGS. 9A to 9C show Embodiment Mode 4.
 FIGS. 10A to 10F show Embodiment Mode 4.
 FIGS. 11A and 11B show Embodiment Mode 5.
 FIGS. 12A to 12C show Embodiment Mode 6.
 FIGS. 13A to 13D show Embodiment Mode 6.
 FIGS. 14A and 14B show Embodiment 1.
 FIGS. 15A and 15B show Embodiment 1.
 FIGS. 16A and 16B show Embodiment 1.
 FIG. 17 shows Embodiment 2.
 FIGS. 18A to 18I show Embodiment 2.
 FIGS. 19A and 19B show Embodiment 3.
 FIG. 20 shows Embodiment 4.
 FIGS. 21A to 21J show Embodiment 5.
 FIGS. 22A to 22D are SEM pictures and pattern diagrams showing Embodiment 5.
 FIGS. 23A to 23 E show examples of electronic devices.

DETAILED DESCRIPTION OF THE INVENTION

A mode carrying out the present invention is described hereinafter. Note that the same number refers to the same part or similar part in a drawing. In addition, description on the same part is omitted.

Embodiment Mode 1

In an electroluminescent device, an insulating film such as a silicon oxide film, a silicon nitride film, an acrylic film, a polyimide film, or a siloxane film is often used as an interlayer insulating film. Specifically, an acrylic film or a siloxane film is a preferable material since it can be formed by application and it has high planarity. However, it has comparatively high permeability on the other hand.

FIGS. 2A and 2B are cross-sectional views taken along a line b-b' in FIG. 3. In the case of conventional structures as shown in FIGS. 2A and 2B, an end face 2 of an interlayer insulating film 1 is always exposed to outer atmosphere. Therefore, there is a case that water enters through the interlayer insulating film and deterioration of a light emitting element is caused, even when an upper portion thereof is covered with an impermeable sealant 3 so that a light emitting element 4 is not exposed to outer air.

Thus, one of structures in the present invention for solving the problem is described with reference to FIGS. 1A to 1C. FIGS. 1A to 1C show an example of reducing water entry through the interlayer insulating film by covering inside of a groove formed on the periphery of the interlayer insulating film with an impermeable film (hereinafter, referred to as a protective film). FIGS. 1A to 1C correspond to a cross section

taken along a line d-d' in FIG. 3, for example. Note that a sealant made of an impermeable material and an opposing substrate are omitted in FIGS. 1A and 1B. A state of the periphery of an electroluminescent device is shown. Reference numeral 100 denotes a substrate; 101, a base insulating film; 102, a first interlayer insulating film; 103, a first protective film; 104, a second interlayer insulating film; and 105, a second protective film.

In this structure, the first interlayer insulating film 102 and the second interlayer insulating film 104 are assumed comparatively highly permeable. In these highly permeable films, a groove-shaped opening 106 that penetrates each film in a thickness direction is formed. The protective films 103 and 105 are formed to cover at least inside of the groove (to continuously cover an end face of an exposed interlayer insulating film and a film in a lower portion). In addition, the protective films 103 and 105 are in contact with each other at the opening 106.

When such a structure is employed, water entered from edge portions of the interlayer insulating films 102 and 104 is prevented from further entering by the impermeable protective films 103 and 105 formed on an end face of the groove-shaped opening 106. Since the groove-shaped opening 106 is formed to penetrate in a thickness direction, an entry path of water is blocked without providing the protective film. Therefore, providing the groove-shaped opening alone becomes a countermeasure for deterioration of a light emitting element due to water, depending on desired degree of reliability.

The groove-shaped opening 106 is the most effective when continuously formed all around the periphery of the permeable film. However, when it is impossible, a certain degree of effect can be expected by forming the opening only on one side or partially since water entry at least from the portion can be reduced.

In FIGS. 1A to 1C, the groove-shaped opening 106 is repeatedly provided from the periphery of the interlayer insulating film to a region provided with a light emitting element, but only one groove-shaped opening 106 may as well be provided. However, reliability is further improved by repeatedly taking such measures.

When the protective films 103 and 105 are made of a wiring material, they can be used as a lead wiring which can be disposed on an outer boundary. Further, a difference between FIG. 1A and FIG. 1B is a difference whether the protective films 103 and 105 are independent in each opening or not. When employing such an independent structure in each opening as shown in FIG. 1B, the protective film in each opening can be used as a separate wiring.

Other structures of suppressing water entry by such a groove-shaped opening and a protective film are conceivable, and some examples of them are given in FIGS. 4A and 4B. Cross-sectional views shown in FIGS. 4A and 4B also correspond to a line d-d' in FIG. 3 or the like. In addition, a sealant made of an impermeable material and an opposing substrate are omitted.

FIGS. 1A to 1C show an example that positions of a first opening formed in the first interlayer insulating film 102 and a second opening formed in the second interlayer insulating film 104 are the same; however, FIGS. 4A and 4B show an example that positions of the first opening formed in the first interlayer insulating film 102 and the second opening formed in the second interlayer insulating film 104 are different. Even such a structure can achieve an effect similar to the structure as shown in FIGS. 1A to 1C and can be formed in a short time since the second opening is shallower than that in FIGS. 1A to 1C. In addition, less attention to disconnection between steps needs to be paid since level difference becomes small, In FIG.

4A and FIG. 4B, a position in which an opening is formed is difference. Reference numeral 101' denotes a base insulating film in FIGS. 4A and 4B.

In addition, the substrate 100 provided with the light emitting element is fixed to an opposing substrate 108 with a sealant 107 made of an impermeable material, and the light emitting element is sealed from the outside. The sealant is more effective in suppressing water entry when formed in an upper portion of the groove-shaped opening 106.

In this embodiment mode, the case of two layers of the interlayer insulating films is described; however, the present invention can be applied in the case of one layer.

Embodiment Mode 2

In this embodiment mode, an example of a structure for preventing water from entering by removing a permeable film on the periphery of a substrate from the periphery of the substrate to a certain distance is described with reference to FIGS. 5A and 5B. Here, the permeable film is assumed an interlayer insulating film. However, an object is not limited to the interlayer insulating film and the present invention can be applied as a countermeasure for the permeable film. The cross-sectional views correspond to a line e-e' in FIG. 3.

Reference numeral 120 denotes a portion from which the interlayer insulating films 102 and 104 are removed on an end face of a substrate in FIG. 5A. In Embodiment Mode 1, the end faces of the interlayer insulating films 102 and 104 are exposed to outer air. Then, appropriate distance of the interlayer insulating films 102 and 104 on the end face of the substrate is removed in this embodiment mode, and the end faces thereof are covered with the protective films 103 and 105. Accordingly, exposure of the end face of the permeable film to outer air can be prevented; therefore, water entry itself can be blocked.

When the sealant 107 made of an impermeable material is formed on an outer side of the end face of the interlayer insulating film covered with the protective film or is formed to cover the entire end face of the interlayer insulating film in fixing the opposing substrate 108, water entry can further be prevented. Therefore, improvement in reliability can be expected. Reference numeral 101' denotes a base insulating film in FIGS. 5A and 5B.

In addition, other structures in this embodiment mode are conceivable, and one example of them is shown in FIG. 5B. A difference between FIG. 5B and FIG. 5A is a removed position of the interlayer insulating films 102 and 104 at the end face of the substrate. FIG. 5A shows a structure in which the end face of the second interlayer insulating film 104 is located on the further outer side of the substrate than the end face of the first interlayer insulating film 102, and FIG. 5B shows a structure in which the end face of the first interlayer insulating film 102 is located on the further outer side of the substrate than the end face of the second interlayer insulating film 104.

Note that two layers of the interlayer insulating films are used in this embodiment mode; however, the present invention can be applied to an electroluminescent device having one layer of an interlayer insulating film.

Moreover, this embodiment mode is more effective when combined with Embodiment Mode 1.

Embodiment Mode 3

As is obvious referring to FIGS. 6A to 6C, in the case of manufacturing a sealing structure of the present invention, an opening 106 and an interlayer insulating film removed portion 120 on an end face of a substrate can be formed simul-

taneously with opening of a contact hole formed in interlayer insulating films 102 and 104, which is effective.

However, a contact hole is etched under such a condition that the interlayer insulating film and a gate insulating film can be etched using a silicon semiconductor layer as an etching stopper. In the opening 106 and the interlayer insulating film removed portion 120 where an etching stopper does not exist, an etching residue may be generated, or a base insulating film 101 may be sharpened, thereby generating unevenness, in etching the first interlayer insulating film 102.

FIG. 7A is a SEM picture of a sample in which a siloxane film is formed over a base film as an interlayer insulating film, a silicon nitride film is formed thereover, a part of the interlayer insulating film is removed under an opening condition of a contact hole, and then a wiring is provided. Regions indicated by "C" and "c" are regions from which the interlayer insulating film is removed, and regions "a", "b", and "c" are provided with a wiring. A region "A" is an original surface without being etched, "B" is an end face of the interlayer insulating film, and "C" is a surface of the base insulating film.

As is obvious seeing this, small unevenness as shown in the region "C" is generated when a contact hole is formed in the interlayer insulating film under the contact hole opening condition to reach the base insulating film. Then, large unevenness as shown in the region "c" is generated by forming a wiring thereover. It is obvious from evenness of a wiring formed over the region "a" that this unevenness is caused by unevenness over the base insulating film after forming the opening. The wiring can be used as a protective film, and this may cause to generate unevenness over the protective film. In addition, coverage of the wiring itself becomes poor.

When such large unevenness is generated, adhesiveness of a sealant made of an impermeable material to be formed thereover may be in danger of being significantly affected. This is because water enters from a portion having poor adhesiveness when the sealant has poor adhesiveness, even when the sealant itself has low permeability.

As in FIG. 7A, FIG. 7B is a SEM picture of a sample in which a siloxane film is formed over a base insulating film as an interlayer insulating film, the interlayer insulating film is removed under the contact hole opening condition, and then a wiring is provided. The region "C" in FIG. 7A corresponds to a region "D" in FIG. 7B, and the region "D" is a surface from which the interlayer insulating film is removed under the contact hole opening condition after forming a base insulating film and an interlayer insulating film in this order over the substrate. The region "c" in FIG. 7A corresponds to a region "E" in FIG. 7B, and the region "E" is a surface in which a wiring is formed over the region "D" in FIG. 7B.

On the other hand, a region "F" in FIG. 7B is a surface of a portion from which the interlayer insulating film is removed under the contact hole opening condition similarly as in the region "D" in FIG. 7B after forming the base insulating film, a silicon film, and the interlayer insulating film in this order over the substrate, that is, forming the silicon film serving as an etching stopper over the base insulating film and forming the interlayer insulating film thereover. Briefly, it has a structure of the region "D" in FIG. 7B provided with an etching stopper of the silicon film. Since the silicon film in the region "F" is removed by etching in forming the wiring in "E", the base insulating film can be seen similarly as in the region "D" in FIG. 7B. The region "F" has a very even surface in comparison with "D" in which a silicon film is not formed under the interlayer insulating film.

This is because the silicon film serves as an etching stopper film and suppresses generation of an etching residue of the

interlayer insulating film in etching the interlayer insulating film and generation of unevenness due to gouge of the base insulating film.

On the basis of this, in this embodiment mode, etching stopper films **130** and **131** are formed in advance in a position to be provided with the opening **106** in FIGS. **1A** to **1C** and the interlayer insulating film removed portion **120** in FIGS. **5A** and **5B** (FIG. **6A**). Cross-sectional views shown in FIGS. **6A** to **6C** correspond to a cross-section taken along a line f-f' in FIG. **3**.

An example of forming such etching stopper films **130** and **131** by using a silicon film forming a semiconductor layer **132** of a thin film transistor (TFT) manufactured in a driver circuit portion or a pixel portion is described in this embodiment mode. However, any film can be used as the etching stopper films **130** and **131** as long as it functions as an etching stopper of the opening **106** and the interlayer insulating film removed portion **120** in removing the interlayer insulating film. It may be made of the same material as the semiconductor layer **132** simultaneously with formation of the semiconductor layer **132** as in this embodiment mode; it may be made of the same material as the gate electrode **133** simultaneously with formation of the gate electrode; or it may separately be made of another material. When it is formed simultaneously with the semiconductor layer **132** or the gate insulating film, it is advantageous since the number of processes does not increase.

The opening **106** and the interlayer insulating film removed portion **120** are formed simultaneously with a contact hole opening for the wiring. In this case, the etching stopper films **130** and **131** (silicon film) are formed in a lower portion of the opening **106** and the interlayer insulating film removed portion **120** in a light emitting device of the present invention. Therefore, unevenness due to an etching residue or gouge of the interlayer insulating film is not generated. If a wiring **134** to be formed later is formed to cover inside of the opening **106** and the end face of the interlayer insulating film in the interlayer insulating film removed portion **120**, it also functions as a protective film **103**. When the interlayer insulating film is removed using the etching stopper films **130** and **131**, an etching residue or gouge over a lower film is not generated. Consequently, adhesiveness of the protective film **103** can be prevented from decreasing, and generation of unevenness on the protective film can be suppressed.

In this embodiment mode, the protective film **103** is made of the same metal film as a material for the wiring **134**, and can be formed simultaneously with the step of forming the wiring. However, it may be made of another material in a different step.

In addition, the protective film **103** may further be covered with a material for an anode **135** of the light emitting element over a switching TFT of a pixel portion to be formed later. It can be expected that water entry can further be suppressed (FIG. **6B**).

An opposing substrate **108** is fixed with a sealant **107** made of an impermeable material after forming the light emitting element. The sealant can block an entry path of water by being applied over the groove-shaped opening **106** and/or the interlayer insulating film removed portion **120** on the periphery of the substrate. Therefore, the sealant is highly effective in suppressing deterioration of the light emitting element. The light emitting element is formed by interposing a light emitting layer **137** between the anode **135** and a cathode **138**, and the light emitting element is separated from every element by a partition **136** (FIG. **6C**).

When this embodiment mode is applied, generation of unevenness of the protective film **103** over the groove-shaped

opening **106** and the interlayer insulating film removed portion **120** on the periphery of the substrate are suppressed. Therefore, deterioration of adhesiveness of the sealant can be prevented, and water entry from a portion having poor adhesiveness can be suppressed, which improves reliability.

This embodiment mode can freely be combined with Embodiment Mode 1 or 2. When combined, water entry from external can further be prevented; accordingly, reliability of an electroluminescent device can further be improved.

Embodiment Mode 4

In this embodiment mode, a structure is described, which can suppress an effect of water entered through an interlayer insulating film in a structure in which it is difficult to remove an entire interlayer insulating film.

As described in Embodiment Modes 2 and 3, it is a very effective means of preventing water entry to remove an interlayer insulating film on the periphery of a substrate and not to expose an end face of an interlayer insulating film to outer air as much as possible by covering the end face of the interlayer insulating film with a protective film **103** (and **105**) and a sealant **107**. However, there may be a case that it is difficult to remove an entire interlayer insulating film, depending on a structure.

For example, a wiring portion connecting an external terminal and an internal circuit is considered (a region "c" in FIG. **3**). The wiring is formed by removing an interlayer insulating film on the periphery of a substrate, forming a metal film serving as a wiring, and etching the metal film to have a desired shape of a wiring, when a structure in which an interlayer insulating film on the periphery of a substrate is removed (a structure in which an interlayer insulating film removed portion **120** is formed: Embodiment Modes 2 and 3) is employed.

However, there is a step **12** that an end face of an interlayer insulating film forms between a portion **10** from which an interlayer insulating film **15** is removed and a portion **11** in which the interlayer insulating film remains. There is a case that a metal film formed in this portion is not sufficiently etched and remains. Such an etching residue **13** makes adjacent wirings **14** short circuit and causes a defect.

A measure that an interlayer insulating film **16** is left between the wirings **14** is taken as shown in FIG. **9** to lessen the interlayer insulating film which is exposed to outer air while preventing the short circuit. Accordingly, a defect due to the above described short circuit can be prevented with most of the interlayer insulating film prevented from being exposed to outer air. However, the interlayer insulating film left between the wirings cannot be removed and is always exposed to outer air; therefore, water entry from the portion cannot be prevented. Water entry from the interlayer insulating film remaining between the wirings may have an adverse effect when considered from the point of view of long-term reliability.

Water entry through the interlayer insulating film is caused by a diffusion phenomenon of water in the film. As for the diffusion phenomenon, it is assumed that time to reach a certain position is proportional to square of distance as is found by a formula of diffusion. Namely, when only the interlayer insulating film left between the wirings is an entry path of water, time for water which enters by diffusing in the interlayer insulating film left between electrodes to reach inside of an electroluminescent device can effectively be lengthened by taking the distance as long as possible.

Conventionally, the wiring portion which connects an external terminal and an internal circuit is straight as shown in

11

FIG. 10A besides a place where a bend is necessary in terms of layout, such as a corner. The wiring 14 is thickly provided with a plurality of bends as shown in FIG. 10B.

Then, substantial length of the interlayer insulating film 16 existing between the wirings can be lengthened, and a distance for water to diffuse in the interlayer insulating film before reaching inside of the electroluminescent device becomes longer. Consequently, time to start to deteriorate can largely be obtained, and longer-term reliability can be secured than ever before.

FIGS. 10C to 10F show examples of other conceivable structures for realizing this embodiment mode. When length of the interlayer insulating film between wirings gets longer even a little than the conventional structure in FIG. 10A, water entry can further be delayed than ever before. A desired pattern may be formed depending on necessity.

When this embodiment mode is applied, area of the interlayer insulating film between the wirings when looked from above of a light emitting device becomes large. Therefore, it is important to dispose a bend of the wiring in such a position that it is not exposed to outer air, that is, inside a sealant made of an impermeable material or in a lower portion of the sealant.

This embodiment mode can be applied by appropriately combining with Embodiment Modes 1 to 3. It is possible to effectively prevent water entry by separately applying Embodiment Modes according to its location, for example, applying this embodiment mode to a wiring portion connecting an external terminal and an internal circuit of an electroluminescent device (a region "c" in FIG. 3 or the like), and Embodiment Modes 1 and 2 to other outer peripheral portions. Further, in this embodiment mode, there is a step of removing an interlayer insulating film in forming a wiring portion. When the structure in Embodiment Mode 3 is employed on that occasion, generation of unevenness over the wiring can be suppressed. Therefore, adhesiveness of a sealant made of an impermeable material is improved, and water entry from an interface between the sealant and the wiring can drastically be decreased.

Embodiment Mode 5

In this embodiment mode, a mode which can remove an interlayer insulating film on the periphery of a substrate also in a wiring portion (a region "c" in FIG. 3 or the like) connecting an external terminal and an internal circuit and prevent water entry through an interlayer insulating film is described with reference to FIGS. 11A and 11B.

It is only in a step 12 on an end face of an interlayer insulating film 15 where an etching residue is generated since it cannot be etched, as shown in FIG. 8. Since the end face of the interlayer insulating film is steep, a wiring material may not be etched by anisotropic dry etching employed for wiring formation and may remain in this portion. In such a wiring portion, it is difficult to employ isotropic etching typified by wet etching in terms of a margin of the wiring.

Thus, the end face 17 of the interlayer insulating film 18 is processed into a gently tapered shape in this embodiment mode. Accordingly, a wiring can certainly be etched even on the end face 17 of the interlayer insulating film, and an etching residue can be prevented from generating; therefore, it becomes unnecessary to leave the interlayer insulating film between the wirings 14 (FIGS. 11A and 11B).

As a result, the interlayer insulating film on the periphery of a substrate can entirely be removed in the wiring portion (a region "c" in FIG. 3 or the like) connecting an external terminal and an internal circuit. Moreover, a water path through

12

the interlayer insulating film can completely be blocked by covering whole outer periphery than a position where the interlayer insulating film exists with an impermeable sealant. Then, reliability of an electroluminescent device can drastically be improved.

Note that the tapered end face of the interlayer insulating film may be processed with an inert gas such as argon. This densifies an end face of the wiring, and has an effect of making it harder for an impurity such as water to enter, compared to the case without processing. In addition, it is preferable to further form a nitride film such as a silicon nitride film to cover the tapered end face of the interlayer insulating film, since water entry from the end face can similarly be suppressed.

This embodiment mode can be applied by appropriately combining with Embodiment Modes 1 and 2. It is possible to effectively prevent water entry by separately applying Embodiment Modes according to its location and necessity, for example, applying this embodiment mode to a wiring portion connecting an external terminal and an internal circuit of an electroluminescent device, and Embodiment modes 1 and 2 to another outer peripheral portion.

Embodiment Mode 6

An example of combining Embodiment Mode 5 and Embodiment Mode 3 is described in this embodiment mode.

In this embodiment mode combining Embodiment Mode 5 and Embodiment Mode 3, an etching stopper film 20 is formed in a portion 10 from which an interlayer insulating film is removed in order to suppress generation of unevenness caused in etching an interlayer insulating film. In this case, a film serving as an etching stopper is formed in a lower portion of a remaining interlayer insulating film 15 in terms of a margin 21 for forming an end face of an interlayer insulating film into a tapered shape (FIG. 12A).

The etching stopper film 20 is formed over an entire surface of the interlayer insulating film removed portion 10, and a wiring 14 is formed thereover. Therefore, when the etching stopper film 20 has conductivity, all the wirings formed in the interlayer insulating film removed portion are short-circuited. However, the etching stopper film in a position 22 where a wiring is not formed is etched and removed with an unnecessary metal film in etching for forming a wiring shape, or is removed by performing appropriate etching again in the case where it cannot be removed by wiring etching. Therefore, there is no need to worry about a short circuit between wirings in the portion. However, an etching stopper film 23 located in a lower portion of the above described remaining interlayer insulating film (the etching stopper film 20 in a position of a taper formation margin 21) remains without being removed since it is covered with the interlayer insulating film. When the film has conductivity, a problem that wirings are short-circuited through the portion is caused (ref. FIG. 12B).

Such a problem does not occur when the etching stopper film is made of an insulating film. However, in the case of forming the etching stopper film without increasing the number of steps, the problem notably occurs since a conceivable film is a silicon film used for a semiconductor layer or a metal film used for a gate electrode and both of them have conductivity.

In this embodiment mode, among the etching stopper film formed below the interlayer insulating film, an etching stopper film is not formed between wirings from the beginning (FIGS. 13A to 13D). Among the etching stopper film formed below the interlayer insulating film, an etching stopper film is

formed to be separated from the etching stopper film located in a lower portion of the wiring (FIGS. 18F to 18I).

When this structure is employed, generation of unevenness in removing an interlayer insulating film can be suppressed also in a wiring portion connecting an external terminal and an internal circuit and unevenness of a wiring can also be suppressed. Accordingly, decrease in adhesiveness of a sealant due to unevenness of a lower film can be prevented, and water entry from a portion having poor adhesiveness of a sealant can drastically be reduced. Consequently, reliability of an electroluminescent device is exceedingly improved.

Embodiment 1

In this embodiment, a detailed embodiment of Embodiment Mode 1 and Embodiment Mode 2 is described with reference to FIGS. 14A and 14B, 15A and 15B, and 16A and 16B.

A first interlayer insulating film 225 is formed over a substrate 200 provided with a base insulating film 201, a driver circuit transistor (only an n-channel thin film transistor 203 and a p-channel thin film transistor 204 are shown in the drawing), and a thin film transistor in a pixel portion (only a switching transistor 205 and a current control transistor 206 are shown in the drawing).

An insulating substrate such as a glass substrate, a quartz substrate, or a crystalline glass, a ceramic substrate, a stainless steel substrate, a metal substrate (tantalum, tungsten, molybdenum, or the like), a semiconductor substrate, a plastic substrate (polyimide, acrylic, polyethylene terephthalate, polycarbonate, polyarylate, polyethersulfone, or the like), or the like can be used as the substrate 200, but a material which can withstand at least heat generated during a process. In this embodiment, a glass substrate is employed.

A silicon oxide film, a silicon nitride film, a silicon oxynitride film, or the like can be used as the base insulating film 201. These are formed by using a known method such as sputtering, low pressure CVD, plasma CVD, or the like. In this embodiment, a silicon nitride oxide film is formed to be 100 nm in thickness.

Subsequently, an amorphous semiconductor film is formed. The amorphous semiconductor film may be made of silicon or a material containing silicon as its main component (for example, SixGe_{1-x} , or the like) to have a desired thickness. As a manufacturing method, a known method such as sputtering, low pressure CVD, plasma CVD can be employed. In this embodiment, the amorphous semiconductor film is made of amorphous silicon to be 50 nm in thickness.

Next, amorphous silicon is crystallized. A step of performing laser crystallization after adding an element that promotes crystallization and crystallizing by heat treatment is described in this embodiment.

A thin film of a nickel solution is formed on the surface of the semiconductor film by applying with a spinner a nickel acetate solution or a nickel nitrate solution containing nickel in a concentration of from 5 ppm to 10 ppm in terms of weight. The nickel element may be sprayed on the whole surface of the semiconductor film by sputtering instead of application. As a catalytic element, one of or a plurality of elements such as iron (Fe), palladium (Pd), tin (Sn), lead (Pb), cobalt (Co), platinum (Pt), copper (Cu), and gold (Au) may be used as well as nickel (Ni).

Subsequently, the amorphous semiconductor film is crystallized by heat treatment. It may be carried out at a temperature of from 500° C. to 650° C. for about 4 hours to 24 hours

since a catalytic element is used. The semiconductor film becomes a crystalline semiconductor film according to this crystallization process.

Subsequently, crystallization by a laser is performed to improve crystallinity. For laser crystallization, a pulse oscillation or continuous oscillation gas, solid, or metal laser oscillation device may be used. A laser oscillated from a laser oscillation device may be radiated in a linear shape by using an optical system.

The semiconductor film crystallized by using metal that promotes the crystallization as in this embodiment contains a metal element used for crystallization in the film. As this residue may cause various disadvantages, the concentration thereof is required to be lowered by gettering.

First, the surface of the crystallized semiconductor film is treated with ozone water, and then a barrier film is formed to have a thickness of from 1 nm to 5 nm, over which a gettering site is formed by sputtering. The gettering site is formed by depositing an amorphous silicon film containing an argon element of 50 nm in thickness. Thereafter, gettering is carried out by heating at 750° C. for 3 minutes by using a lamp annealing device to remove the gettering site.

After gettering, the crystalline semiconductor film is etched into semiconductor layers 207 to 210 having desired shapes. Thereafter, a gate insulating film 211 is formed. An insulating film containing silicon may be formed in a thickness of approximately 115 nm by low pressure CVD, plasma CVD, sputtering, or the like. A silicon oxide film is formed in this embodiment.

A tantalum nitride (TaN) film of 30 nm in thickness is formed as a first conductive layer over the gate insulating film 211, and a tungsten (W) film of 370 nm in thickness is formed as a second conductive layer thereover. Note that the first conductive layer is a TaN film of 30 nm in thickness and the second conductive layer is a W film of 370 nm in thickness in this embodiment; however, the present invention is not limited thereto. The first and second conductive layers may be made of any element selected from Ta, W, Ti, Mo, Al, Cu, Cr, and Nd, or an alloy or compound material having the above element as a main component. Furthermore, a semiconductor film typified by a polycrystalline silicon film doped with an impurity element such as phosphorous may be used. The first conductive layer may be formed to have a thickness of from 20 nm to 100 nm, and the second conductive layer may be formed to have a thickness of from 100 nm to 400 nm. In this embodiment, a laminated structure of two layers is employed; however, a single layer structure may be employed, or three or more layers may be laminated as well.

In order to form an electrode and a wiring by etching the conductive layer, a resist is formed as a mask through exposure to light by photolithography. First etching treatment is carried out under first and second etching conditions. Etching is carried out using the mask made of a resist to form a gate electrode and a wiring. An etching condition may be determined in each case.

In this method, ICP (Inductively Coupled Plasma) etching is used. As the first etching condition, CF_4 , Cl_2 , and O_2 are used as an etching gas with the gas-flow ratio of 25/25/10 (sccm), and a pressure of 1.0 Pa and an RF (13.56 MHz) power of 500 W is applied on a coil electrode to generate plasma for etching. An RF (13.56 MHz) power of 150 W is applied to a substrate side (sample stage) to apply a substantially negative self bias voltage. The W film is etched under the first etching condition to make an edge portion of the first conductive layer into a tapered shape. An etching rate on the W film under the first etching condition is 200.39 nm/min, the etching rate on the TaN film is 80.32 nm/min, and the selec-

tivity ratio of W relative to TaN is approximately 2.5. Further, a taper angle of the W film is about 26° under the first etching condition.

Subsequently, etching is carried out under the second etching condition. Etching is performed for about 15 seconds with the resist as a mask remained, by using CF₄ and Cl₂ as an etching gas with the gas-flow ratio of 30/30 (sccm), and a pressure of 1.0 Pa and an RF (13.56 MHz) power of 500 W is applied on the coil electrode to generate plasma for etching. An RF (13.56 MHz) power of 20 W is applied to a substrate side (sample stage) to apply a substantially negative self bias voltage. Under the second etching condition in which CF₄ and Cl₂ are mixed, both of the W film and the TaN film are etched to the same extent. The edge portions of the first and second conductive layers become tapered in the first etching due to bias voltage applied to the substrate.

The second etching is carried out without removing the resist as a mask. The second etching is performed using SF₆, Cl₂, and O₂ as an etching gas with the gas-flow ratio of 24/12/24 (sccm), and a pressure of 1.3 Pa and an RF (13.56 MHz) power of 700 W is applied on the coil electrode to generate plasma for etching for about 25 seconds. An RF (13.56 MHz) power of 10 W is applied to a substrate side (sample stage) to apply a substantially negative self bias voltage. The W film is selectively etched under this etching condition to form a conductive layer in a second shape. The first conductive layer is hardly etched at this time. Gate electrodes including the first conductive layers **212a** to **215a** and the second conductive layers **212b** to **215b** are formed by the first and second etching.

First doping is carried out without removing the resist as a mask. Thus, an N-type impurity is doped in a low concentration into a crystalline semiconductor layer. The first doping may be performed by ion doping or ion implantation. The ion doping may be performed with the dose amount of from 1×10¹³ atoms/cm² to 5×10¹⁴ atoms/cm², and an acceleration voltage of from 40 kV to 80 kV. The ion doping is carried out at an acceleration voltage of 50 kV in this embodiment. The N-type impurity may be an element belonging to the group 15 of the periodic table typified by phosphorous (P) or arsenic (As). Phosphorous (P) is used in this embodiment. The first conductive layer is used as a mask to form a first impurity region (N⁻ region) in a self-aligned manner to which an impurity of low concentration is doped.

Subsequently, the resist as a mask is removed. Then, a mask made of a resist is newly formed and the second doping is carried out at a higher acceleration voltage than the first doping. The N-type impurity is doped in the second doping as well. The ion doping may be performed with the dose amount of from 1×10¹³ atoms/cm² to 3×10¹⁵ atoms/cm², and an acceleration voltage of from 60 kV to 120 kV. The ion doping is carried out with the dose amount of 3.0×10¹⁵ atoms/cm² and an acceleration voltage of 65 kV in this embodiment. The second doping is carried out so that the impurity element is doped into the semiconductor layer under the first conductive layer by using the second conductive layer as a mask against the impurity element.

By the second doping, a second impurity region (N⁻ region, Lov region) is formed on the part where the second conductive layer is not overlapped or the part which is not covered with the mask in the part where the crystalline semiconductor layer is overlapped with the first conductive layer. The N-type impurity of which concentration ranging from 1×10¹⁸ atoms/cm³ to 5×10¹⁹ atoms/cm³ is doped into the second impurity region. Further, the exposed part (third impurity region: N⁺ region) which is not covered with either the conductive layer in a first shape nor the mask is doped with

a high concentration N-type impurity ranging from 1×10¹⁹ atoms/cm³ to 5×10²¹ atoms/cm³. The semiconductor layer has an N⁺ region, a part of which is covered only with the mask. The concentration of the N-type impurity of this part is not changed from the impurity concentration of the first doping. Therefore, this part is referred to as the first impurity region (N⁻ region) as it is.

Note that each impurity region is formed by two doping treatment in this embodiment; however, the invention is not exclusively limited to this. The impurity region having a desired impurity concentration may be formed by one or multiple doping by determining the condition in each case.

Subsequently, the resist as a mask is removed and a mask made of a resist is newly formed for third doping. By the third doping, a fourth impurity region (P⁺ region) and a fifth impurity region (P⁻ region) are formed in which an impurity element having the opposite conductivity to the ones of the first and second conductive layers is added to a semiconductor layer serving as a P channel TFT.

The fourth impurity region (P⁺ region) is formed on the part which is not covered with the resist as a mask and not overlapped with the first conductive layer, and the fifth impurity region (P⁻ region) is formed on the part which is not covered with the resist as a mask, overlapped with the first conductive layer, and not overlapped with the second conductive layer. The P-type impurity element may be boron (B), aluminum (Al), or gallium (Ga), each of which belongs to the group 13 of the periodic table.

In this embodiment, boron is used as a P-type impurity element to form the fourth and fifth impurity regions by ion doping using diborane (B₂H₆). Ion doping is carried out with the dose amount of 1×10¹⁶ atoms/cm² and an acceleration voltage of 80 kV.

Note that semiconductor layers **207** and **209** for forming N-channel TFTs are covered with the mask made of a resist in the third doping.

The fourth impurity region (P⁺ region) and the fifth impurity region (P⁻ region) are doped with phosphorous of different concentrations by the first and second doping. However, in both of the fourth impurity region (P⁺ region) and the fifth impurity region (P⁻ region), the third doping is performed so that the concentration of the P-type impurity element is from 1×10¹⁹ atoms/cm² to 5×10²¹ atoms/cm². Therefore, the fourth impurity region (P⁺ region) and the fifth impurity region (P⁻ region) work as a source region and a drain region of a P-channel TFT without problems.

It should be noted that the fourth impurity region (P⁺ region) and the fifth impurity region (P⁻ region) are formed by once third doping; however, the invention is not exclusively limited to this. The fourth impurity region (P⁺ region) and the fifth impurity region (P⁻ region) may be formed by multiple doping treatments according to each condition.

By the aforementioned doping treatment, a first impurity region (N⁻ region) **216**, a second impurity region (N⁻ region, Lov region) **217**, third impurity regions (N⁺ region) **218** and **219**, fourth impurity regions (P⁺ region) **220** and **221**, and fifth impurity regions (P⁻ region) **222** and **223** are formed.

Thereafter, a first passivation film **224** is formed over a gate electrode and a gate insulating film. A silicon nitride film, a silicon oxynitride film, or a silicon nitride oxide film containing hydrogen is formed as the first passivation film.

Subsequently, the first interlayer insulating film **225** is formed. After a siloxane polymer is entirely applied as the first interlayer insulating film, it is dried by heat treatment at a temperature of from 50° C. to 200° C. for 10 minutes, and baking treatment is performed at a temperature of from 300° C. to 450° C. for 1 hour to 12 hours. A siloxane film having a

thickness of 1 μm , in which a skeletal structure is made up of a bond of silicon (Si) and oxygen (O), is formed over an entire surface by the baking. This step can hydrogenate a semiconductor layer by hydrogen contained in the first passivation film **224** as well as baking the siloxane polymer; consequently, the number of steps can be reduced and processes can be simplified.

An inorganic insulating film, an organic material resin, a low-k material, or the like formed by a known method such as a CVD method can be used for the first interlayer insulating film.

Thereafter, a silicon nitride oxide film or a silicon oxynitride film may be formed by a CVD method to cover the first interlayer insulating film **225**. When a conductive film to be formed later is etched, this film functions as an etching stopper and can prevent the interlayer insulating film from being overetched. Further, a silicon nitride film may be formed thereover by sputtering. The silicon nitride film has a function of suppressing movement of an alkaline metal ion; therefore, a metal ion from a pixel electrode to be formed later, such as a lithium element or sodium can be prevented from moving to a semiconductor thin film.

Subsequently, the first interlayer insulating film is patterned and etched to form a contact hole **226** reaching the thin film transistors **203** to **206**, a groove-shaped opening **227**, and an interlayer insulating film removed portion **228** on the periphery of a substrate.

The contact hole **226**, the opening **227**, and the interlayer insulating film removed portion **228** can be formed by etching the siloxane film using a mixed gas of CF_4 , O_2 , and He, and then etching and removing the silicon oxide film that is a gate insulating film using a CHF_3 gas.

Subsequently, a metal film is laminated within the contact hole **226** and is patterned to form a source electrode and a drain electrode. In this embodiment, a titanium film including a nitrogen atom, a titanium-aluminum alloy film, and a titanium film are laminated to be 100 nm/350 nm/100 nm in thickness, respectively. Then, the films are patterned and etched into a desired shape to form source/drain electrodes **229** to **235** and a pixel electrode **236** of three layers.

A titanium film including a nitrogen atom in the first layer is formed by sputtering using titanium as a target with a flow rate of nitrogen and argon set 1:1. When the titanium film including a nitrogen atom as described above is formed over an interlayer insulating film made of a siloxane film, a wiring which is hardly peeled and which has a low resistance connection with a semiconductor region can be formed.

In this embodiment, a top gate polysilicon TFT is formed in both a driver circuit portion and a pixel portion; however, a TFT in the pixel portion may be a TFT using amorphous silicon as an active layer or a TFT using microcrystalline silicon as an active layer. In addition, a bottom gate TFT can naturally be used.

At the same time that a source electrode and a drain electrode are formed, a first protective film **237** is made of the same material to cover inside of the groove-shaped opening **227** and an end face of the interlayer insulating film removed portion **228** on the periphery of the substrate.

Subsequently, a second interlayer insulating film **238** is formed over an entire surface of the substrate. The second interlayer insulating film **238** can be made of the same material as the first interlayer insulating film **225**. In this embodiment, the second interlayer insulating film **238** is made of the same siloxane film as the first interlayer insulating film.

Thereafter, a contact hole **239**, a groove-shaped opening **240**, and an interlayer insulating film removed portion **241** on the periphery of the substrate, which are to be connected to a

pixel electrode, are formed under the same condition as that in etching the first interlayer insulating film.

In this embodiment, both the first interlayer insulating film **225** and the second interlayer insulating film **238** are made of a siloxane film; however, a structure of the interlayer insulating film is not limited thereto. The structure can appropriately be changed to a combination of an organic film for the first interlayer insulating film and an inorganic film for the second interlayer insulating film, the opposite combination thereof, a combination of an organic film and an organic film, a combination of an inorganic film and an inorganic film, or the like. A protective film may be formed only over either the first interlayer insulating film or the second interlayer insulating film depending on permeability of a selected interlayer film.

After a contact hole is formed in the second interlayer insulating film **238**, a first electrode serving as an anode of a light emitting element is continuously formed in the contact hole **239** connected to the pixel electrode and over the second interlayer insulating film **238**. An electrode of the light emitting element is a laminate of Al—Si(**260a**)/TiN(**260b**)/ITSO (**260c**). Here, Al—Si is aluminum containing silicon of approximately from 1 atomic % to 5 atomic %, and ITSO is a material in which ITO is mixed with SiO_2 .

At the same time that the anode of the light emitting element is formed, inside of the groove-shaped opening **240** and the end face of the interlayer insulating film **238** at the interlayer insulating film removed portion **241** on the periphery of the substrate is covered with a protective film **242**. The protective film may be formed with the electrodes **260a** to **260c** of the light emitting element. All of the three layers **260a** to **260c** may be used, or one or two of the layers may be used.

Subsequently, an insulator **243** is formed to cover an end face of the first electrode. The insulator **243** can be made of an inorganic or organic material. Silicon oxide, silicon oxynitride, siloxane, acrylic, polyimide, or the like can be given. It is preferable to form the insulator **243** by using a photosensitive organic material, since a shape of the opening becomes such a shape that a radius of curvature continuously changes and disconnection between the steps or the like hardly occurs when evaporating a light emitting layer.

Then, evaporation is performed with an evaporation source moving by using an evaporation apparatus. For example, evaporation is performed in a film formation chamber which is vacuum evacuated to 5×10^{-3} Torr (0.665 Pa) or less, preferably to from 10^{-4} Torr to 10^{-6} Torr. When evaporation is performed, an organic compound is previously vaporized by resistance heating and flies in a direction of the substrate when a shutter is opened in evaporation. The vaporized organic compound flies upwardly and is evaporated to the substrate through an opening provided for a metal mask to form a light emitting layer **244** (including a hole transport layer, a hole injection layer, an electron transport layer, and an electron injection layer).

In this embodiment, the light emitting layer is formed by evaporation; therefore, a low molecular weight light-emitting material is used. However, the light emitting layer is formed also by using a high molecular weight material and an intermediate molecular weight material having characteristics between a low molecular weight material and a high molecular weight material. A high molecular weight material can be applied using spin coating or ink jetting by dissolving into a solvent. In addition, a composite material with an inorganic material as well as an organic material can also be used.

It is assumed that a light emitting mechanism of a light emitting element emits light in such a way that an electron injected from a cathode and a hole injected from an anode form a molecular exciton by recombining at the center of light

emission in an organic compound layer when voltage is applied to the organic compound layer interposed between a pair of electrodes, and energy for light emission is released when the molecular exciton turns back to the ground state. The excited state is known to include a singlet excited state and a triplet excited state, through either of which light can be emitted.

A light emitting layer typically has a laminated structure. The typical laminated structure is constituted as "a hole transport layer, an electroluminescent layer, and an electron transport layer." This structure has such a high luminous efficiency that light emitting devices that are recently researched and developed mostly employ this structure. A structure in which a hole injection layer, a hole transport layer, an electroluminescent layer, and an electron transport layer are laminated over the anode in this order, or a structure in which a hole injection layer, a hole transport layer, an electroluminescent layer, an electron transport layer, and an electron injection layer are laminated over the anode in this order may be employed as well. A fluorescent pigment or the like may be doped into the electroluminescent layer.

Subsequently, a second electrode **245** is formed as a cathode over the light emitting layer. The second electrode **245** may be made of a thin film containing a metal with a low work function (Li, Mg, or Cs). In addition, it is preferable that the second electrode is made of a laminated film in which a transparent conductive film (ITO (indium tin oxide), indium zinc oxide ($\text{In}_2\text{O}_3\text{—ZnO}$), zinc oxide (ZnO), or the like) is laminated over the thin film containing Li, Mg, Cs, or the like. Further, the second electrode may be formed to be from 0.01 μm to 1 μm in thickness by electron beam evaporation, although the film thickness may be determined appropriately to serve as a cathode.

Such a light emitting element enables both monochrome display and multicolor display by selection and arrangement of the light emitting layer. For monochrome display, all light emitting elements are manufactured by using one material; however, there are several methods for multicolor display. One is a separately coloring method. The separately coloring method realize multicolor display by separately coloring a light emitting layer which emits light of an objective color in a necessary portion. Another method is a color conversion method. Light emitting layers are made of one material, and a color conversion layer is provided only in a necessary portion. Light emitted from the light emitting layer is converted into a desired color through the color conversion layer, thereby realizing multicolor display. Another method is a method for providing a color filter for a white light emitting element. This method realizes multicolor display by forming a light emitting layer which emits white light all over the pixel portion and by passing through a color filter. In all of the methods, the light emitting layer is formed so that three primary colors of light of RGB are provided every pixel in the case of full color display. Thus, the light emitting device can perform monochrome, multicolor, and full color display.

An opposing substrate **248** is fixed to the substrate with a sealant **247** made of an impermeable material for sealing after a light emitting element **246** is completed in this way. The sealant **247** made of an impermeable material further firmly blocks off a water entrance and entry path when formed to cover an end face of an interlayer insulating film covered with a protective film in the groove-shaped openings **227** and **240** around an insulating film provided with a protective film and in the interlayer insulating film removed portions **228** and **241** on the periphery of the substrate, which greatly contributes to

improvement in reliability. An impermeable ultraviolet curable resin may be used as the sealant **247** made of an impermeable material.

According to the above described steps, an electroluminescent device resistant to deterioration due to water entered from exterior can be manufactured, and reliability of the electroluminescent device can drastically be improved. Note that only one groove-shaped opening around an interlayer insulating film in a sealing portion is provided in this embodiment; however, a plurality of openings can be provided. Reliability is further improved by providing a plurality of openings.

Embodiment 2

In this embodiment, an embodiment regarding Embodiment Mode 5 and Embodiment Mode 6 is described with reference to FIGS. **17** and **18A** to **18I**. In FIG. **17**, an interlayer insulating film has a single layer structure; however, it may be regarded as having the same structure as in Embodiment 1. A structure of a first electrode in a light emitting element is different, but it is described below.

FIG. **17** is a cross-sectional view taken along a line f-f' in FIG. **3**. In FIG. **17**, an etching stopper film **250** is formed in a groove-shaped opening on the periphery of an interlayer insulating film and in an interlayer insulating film removed portion on the periphery of a substrate. The etching stopper film **250** can be formed at the same time as formation of a semiconductor layer of a transistor in a driver circuit portion or a pixel portion. It functions as an etching stopper in etching an interlayer insulating film **251** and has effect of improving adhesiveness of a sealant made of an impermeable material by reducing generation of an etching residue or unevenness.

Since it is similar to Embodiment 1 up to manufacturing a source electrode and a drain electrode except to have the etching stopper film **250**, explanation is omitted. After a source electrode and a drain electrode are formed, a first electrode **252** of a light emitting element is formed to be in contact with an electrode **255** of a switching TFT in a pixel portion. In this embodiment, the first electrode **252** of the light emitting element is manufactured over an interlayer insulating film provided with the source electrode and the drain electrode. Therefore, it is not necessary to manufacture a second interlayer insulating film. A material similar to the first electrode in Embodiment 1 can be used as a material for the first electrode **252** or the like, and a process after manufacturing the first electrode is similar to Embodiment 1; therefore, explanation is omitted.

Here, light can be extracted in a direction of a substrate **200** when the first electrode is made of a transparent conductive film typified by ITO. In addition, light can be extracted in both directions of the substrate **200** and an opposing substrate **248** when a second electrode is also similarly made of a transparent material.

FIGS. **18A** to **18I** show a method for manufacturing a region "c" in FIG. **3**. FIGS. **18A** to **18E** are cross-sectional views taken along a line a-a' in FIG. **3**, and FIGS. **18F** to **18I** are top views of the region "c" in FIG. **3**. FIGS. **18A** to **18E** and FIGS. **18F** to **18I** adjacent to each other respectively show a diagram of the same step. In FIGS. **18A** to **18I**, a left side is a direction of an FPC and a right side is a direction of a display portion. Since FIGS. **18F** to **18I** have a direction different from that in the region "c" in FIG. **3**, it is necessary to be paid attention to.

When a transistor and a first insulating film are formed in a display portion in this embodiment, a base insulating film **301** is formed over a substrate **300** in a wiring portion connecting

an external terminal and an internal circuit. An etching stopper film **302** (silicon film) is formed in a portion from which an interlayer film is removed over the base insulating film **301**; an insulating film **303** functioning as a gate insulating film is formed to cover the etching stopper film **302** (silicon film) and the base insulating film **301**; and then, a first interlayer insulating film **304** is formed to cover the same. An acrylic film or a siloxane film can be employed for the first interlayer film; however, a siloxane film is used in this embodiment (FIGS. **18A** and **18F**).

Thereafter, the first interlayer insulating film **304** is etched and removed to have a tapered shape on an end face thereof, thereby forming an interlayer insulating film removed portion **305** on the periphery of the substrate. The etching stopper film **302** (silicon film) serving as an etching stopper is formed in advance in the interlayer insulating film removed portion **305**. Therefore, a surface of the interlayer insulating film removed portion **305** after removal is even, and unevenness due to an etching residue or gouge of a base film is not caused. (FIGS. **18B** and **18G**)

Subsequently, a metal film **306** serving as a wiring is formed. The metal film may be made of the same material as the source electrode and the drain electrode in the driver circuit portion or the pixel portion. A specific material is similar to the material for the source electrode and the drain electrode in Embodiment 1 (FIGS. **18C** and **18H**).

The metal film **306** is etched simultaneously with etching for forming the source electrode and the drain electrode in order to form a wiring **307**. At this time, a portion without being covered with the wiring **307** of the etching stopper film **302** (silicon film) formed in the interlayer insulating film removed portion **305** is removed by the etching. When an etching stopper film **302** which is not located below the wiring **307** and is formed in a position **308** below a remaining interlayer insulating film **304** is previously formed in such a shape that it is separated from the etching stopper film **309** (silicon film) located below the wiring **307** after wiring etching, wirings adjacent to each other do not short-circuit, even if the etching stopper film **302** is made of a conductive material (FIGS. **18D**, **18E**, and **18I**).

Generation of unevenness in the interlayer insulating film removed portion **305** can be prevented and generation of large unevenness on a wiring to be formed thereafter can also be suppressed by forming the etching stopper film **302** (silicon film) as an etching stopper. Adhesiveness of a sealant made of an impermeable material to be formed thereover can be maintained, and water entering from a portion having poor adhesiveness of a sealant can be reduced.

When such a structure is employed, an interlayer insulating film can be removed also in a wiring portion connecting an external terminal portion (such as an FPC) and an internal circuit, and the interlayer insulating film can be prevented from being exposed to outer air. Consequently, water entry can drastically be reduced, which contributes to improvement in reliability of an electroluminescent device.

After removing the first interlayer insulating film on the periphery of the substrate to have a tapered shape on its end face and before forming metal for a wiring, it is useful to form a nitride film such as a silicon nitride film or a carbon nitride film thereover by CVD in order to prevent moisture from entering from an end face (not shown). Higher reliability can be obtained by forming such a nitride film.

In this embodiment, the first interlayer insulating film on the periphery of the substrate is removed by the same step as opening of a contact hole in a pixel portion and a driver circuit portion. Therefore, in the pixel portion and a driver circuit portion, conduction between a wiring in a lower layer or the

like and a wiring formed over the first interlayer insulating film, which is to be performed through the contact hole, may not be made, when the nitride film is formed after removing the first interlayer insulating film. Thus, in a portion which is required to electrically be in contact with a lower portion, a nitride film in the portion is preferably removed before forming metal for a wiring. When a nitride film is formed over the first interlayer insulating film, moisture can be prevented from entering from an end face of an interlayer insulating film in such a contact hole portion. Consequently, further higher reliability can be obtained.

Embodiment 3

In this embodiment, an example of a pixel structure in an electroluminescent device to which a structure of the present invention is applied is described with reference to FIGS. **19A** and **19B**.

FIGS. **19A** and **19B** show an element structure of one pixel. The display portion in FIG. **3** is formed by arranging a plurality of such pixels in matrix. Naturally, this pixel structure is merely an example, and any other conceivable pixel structures may be employed.

In FIGS. **19A** and **19B**, a top emission structure is adopted. One pixel includes a source line **400**, a driver TFT gate line **401**, an anode line **402**, an erasing gate line **403**, a writing gate line **404**, an erasing TFT **405**, a writing TFT **406**, a driver TFT **407**, a display TFT **408**, an AC driving diode **409**, a capacitor **410**, a drain electrode **411** of a driver TFT, and a driver TFT gate line **412**.

Then, a light emitting element **413** is formed in an upper portion thereof through an insulating film, and an anode or a cathode of a light emitting element is connected to the drain electrode **411** of a driver TFT.

Embodiment 4

In this embodiment, a structure of a source driver that is required to display an image in an electroluminescent device is described with reference to FIG. **20**.

In a row where a gate signal line is selected, a shift register **500** (SR) outputs a sampling pulse sequentially from a first stage in accordance with a clock pulse **504** and a start pulse **505**. A first latch circuit **501** takes in a video signal in timing with a sampling pulse being inputted, and the video signal taken in at each stage is stored in the first latch circuit **501**.

According to a sampling pulse outputted from one shift register **500**, three latch circuits A, B, and C in the first latch circuit **501** take in signals inputted from video lines DATA **01** to **20**, DATA **21** to **40**, DATA **41** to **60**, respectively. A sampling pulse outputted from the shift register **500** in the first stage takes in a video signal for being charged and discharged in a source signal line from **S01** to **S60** among source signal lines from **S01** to **S1920**. In the first latch circuit that takes in a video signal in response to a sampling pulse of the shift register **500** in the first stage, the latch circuit A stores a video signal for source signal lines from **S01** to **S20**; B, from **S21** to **S40**; and C, from **S41** to **S60**. Subsequently, the first latch circuit that takes in a video signal in response to a sampling pulse outputted from the shift register in the second stage takes in a video signal for source signal lines from **S61** to **S120**. The latch circuits A, B, and C store a video signal for source signal lines from **S61** to **S80**, from **S81** to **S100**, and from **S101** to **S120**, respectively. Similarly, a shift register in the 32nd stage takes in and stores a video signal for source signal lines from **S1861** to **S1920**; then, taking in a video signal for one row is completed.

When a latch pulse (LAT) **506** is outputted after taking in a video signal for one row is completed, the video signal stored in the first latch circuit **501** is transferred to a second latch circuit **502** all at once, and all signal lines are charged and discharged all at once. A level shifter and a buffer for making output from the second latch circuit **502** a desired size may appropriately be provided as necessary.

The above-mentioned operation is repeated from the first row to the last row, thereby completing writing for one frame. Thereafter, similar operations are repeated to display an image.

Note that a source driver having this structure is merely an example, and the present invention can be applied even if any other structures of a source driver are employed.

Embodiment 5

A method for forming an end face of an insulating film into a tapered shape as described in Embodiment Mode 5 is described in this embodiment.

When isotropic etching such as wet etching can be performed and there are a margin in etching and a certain film thickness, a tapered shape can easily be obtained.

A method for forming an insulating film into a tapered shape by anisotropic dry etching is described in this embodiment.

First, a method for processing an object into a desired shape by dry etching using an etching mask previously manufactured by a conventional method is described with reference to FIGS. **21A** to **21E**.

A mask material **602** such as a photosensitive resist or polyimide is formed over an entire surface of an object to be processed **601** by application or the like (FIG. **21A**). A positive resist is given as an example in this description.

Subsequently, pre-bake at low temperature for vaporizing and stabilizing a material in the resist is performed; thereafter, the resist is partially exposed to light through a photomask **603** in a desired shape (FIG. **21B**).

After a portion exposed to light by the light-exposure is dissolved in developer and is removed (FIG. **21C**), baking is performed to improve adhesiveness of the resist and to improve resistance to an etchant to be used in the next step. An etching mask for an object is formed so far. The step so far is referred to as photolithography.

An object can be processed into a desired shape by etching the object using the mask and an appropriate etchant (FIG. **21D**).

Here, the end face of the etching mask is at large angle to the object located in a lower portion. Therefore, the end face of the object which is located in a lower portion becomes steep reflecting the shape of the end face of the etching mask, when anisotropic etching such as dry etching is performed. When an interlayer insulating film on the periphery of the substrate is removed and a wiring is formed in such a way, an etching residue of a wiring as described in Embodiment Mode 4 or 5 is generated on an end face of the interlayer insulating film, which causes a defect due to wiring short circuit.

Consequently, in forming a mask by photolithography, a slit **605** having narrower width than limit of resolution of a photolithography apparatus used for light-exposure is formed on an end face of a portion of the photomask **604** which is preferably formed into a tapered shape. A mask material such as a resist which is exposed to light through a slit and a pattern having narrower width than resolution of a photolithography apparatus is not completely exposed to light in the portion. A

mask of which film thickness is decreased remains even after removing a light-exposed portion with developer.

An incomplete light-exposed portion as described above is provided between a non-light-exposed portion and a complete light-exposed portion in a photosensitive mask material such as a resist by thus forming a slit or a hole having width equal to or narrower than light-exposure resolution of a photolithography apparatus in a photomask. Accordingly, an end face of an etching mask can be formed into a tapered shape.

When anisotropic etching typified by dry etching is performed using the etching mask having a tapered shape under such a condition that both the object in a lower layer and the mask are etched, the etching mask disappears where thickness thereof is thin at the same time that the object is etched. According to disappearance of the etching mask, an object newly exposed to etching atmosphere is sequentially etched, thereby obtaining an object having a shape nearly reflecting a shape of the etching mask (FIGS. **21F** to **21J**).

An object (an interlayer insulating film in Embodiment Mode 5) having a similar tapered shape on an end face thereof is obtained by using the etching mask having a tapered shape on an end face thereof.

A shape of a photosensitive material after development can freely be formed depending on shapes of a slit, a pattern, and a hole of a photomask in exposing to light. FIGS. **22A** to **22D** show an example thereof. FIGS. **22A** and **22C** are SEM pictures of a sample in which a siloxane film is formed over a substrate, a resist is applied thereover, exposed to light with a photomask **700**, and etched by dry etching, and FIGS. **22B** and **22D** are schematic diagrams of a photomask. The SEM pictures show that a resist is exposed to light with a photomask having such a pattern as the photomask **700** shown in FIG. **22B** or **22D**.

While only a portion **701** is exposed to light with a typical photomask, a cross-sectional shape as shown in the SEM picture can be obtained in FIGS. **22A** to **22D** by forming a pattern **702** equal to or narrower than limit of resolution of a photolithography apparatus in a photomask.

As shown in FIGS. **22A** to **22D**, an object can have various shapes by changing a shape of the pattern **702** equal to or narrower than limit of resolution of a photolithography apparatus. An object having a shape that cannot be formed ever before can be manufactured by appropriately changing an object material and an etching condition using the thus formed etching mask.

Embodiment 6

Examples of electronic devices to which the present invention is applied can be given as a video camera, a digital camera, a goggle type display (head mounted display), a navigation system, an audio reproducing device (car audio, an audio component, or the like), a laptop personal computer, a game machine, a personal digital assistant (a mobile computer, a cellular phone, a portable game machine, an electronic book, or the like), and an image reproducing device including a recording medium (specifically, a device capable of processing data in a recording medium such as a Digital Versatile Disk (DVD) and having a display that can display the image of the data). Practical examples of these electronic devices are shown in FIGS. **23A** to **23E**.

FIG. **23A** shows a wall-mounted display device, which includes a chassis **2001**, a display portion **2003**, a speaker portion **2004**, and the like. The present invention is applied to manufacturing of the display portion **2003**. Longer-term reliability can be secured by employing the present invention.

25

FIG. 23B shows a digital still camera, which includes a main body 2101, a display portion 2102, an image receiving portion 2103, operation keys 2104, an external connection port 2105, a shutter 2106, and the like. The present invention can be applied to the display portion 2102. Although a digital still camera is often used outside and tends to be put in a harder condition than indoors, long-term reliability can be obtained even under a comparatively hard condition by employing the present invention.

FIG. 23C shows a laptop personal computer, which includes a main body 2201, a chassis 2202, a display portion 2203, a keyboard 2204, an external connection port 2205, a pointing mouse 2206, and the like. The present invention can be applied to the display portion 2203. A laptop personal computer can conceivably be carried around and used, which is different from a desktop computer. Similarly as a digital still camera, possibility of use under a more adverse condition than a monitor of a desktop computer increases by being carried around. Longer-term reliability can be secured even under such a condition by employing the present invention.

FIG. 23D shows a mobile computer, which includes a main body 2301, a display portion 2302, a switch 2303, operation keys 2304, an infrared port 2305, and the like. The present invention can be applied to the display portion 2302. Although a mobile computer is often used outside and tends to be put in a harder condition than indoors, long-term reliability can be obtained even under a comparatively hard condition by employing the present invention.

FIG. 23E shows a portable game machine, which includes a chassis 2401, a display portion 2402, a speaker portion 2403, operation keys 2404, a recording medium insertion portion 2405, and the like. The present invention can be applied to the display portion 2402. Although a portable game machine is often used outside and tends to be put in a harder condition than indoors, long-term reliability can be obtained even under a comparatively hard condition by employing the present invention.

As described above, the applicable range of the present invention is so wide that the invention can be applied to electronic devices of various fields. In addition, reliability of a product improves, so that reliability as a manufacturer can also be improved.

This application is based on Japanese Patent Application serial no. 2003-347601 filed in Japan Patent Office on Aug. 29 in 2003 and no. 2003-322334 filed on Sep. 12 in 2003, the contents of which are hereby incorporated by reference.

Although the present invention has been fully described by way of example with reference to the accompanying drawings, it is to be understood that various changes and modifications will be apparent to those skilled in the art. Therefore, unless otherwise such changes and modifications depart from the scope of the present invention hereinafter defined, they should be construed as being included therein.

What is claimed is:

1. A light emitting device comprising:

- a first substrate;
- a thin film transistor over the first substrate;
- a first interlayer insulating film formed over the thin film transistor;
- a source or drain electrode formed on the first interlayer insulating film;
- a light emitting element formed over the first interlayer insulating film;
- a second interlayer insulating film formed over the first interlayer insulating film; and
- a second substrate provided over the light emitting element,

26

wherein a side surface of the first interlayer insulating film is tapered at a region in which the first and second substrates are fixed to each other with a sealing material, wherein the side surface of the first interlayer insulating film is covered and in contact with a first protective film, wherein a side surface of the first protective film is covered with the second interlayer insulating film, wherein a side surface of the second interlayer insulating film is covered and in contact with a second protective film, wherein the sealing material covers the side surface of the first interlayer insulating film and the side surface of the second interlayer insulating film at the region, and wherein the first protective film is the same material as the source or drain electrode.

2. A light emitting device according to claim 1, wherein the light emitting element is electrically connected to a thin film transistor.

3. A light emitting device according to claim 1, wherein at least one of the first and the second interlayer insulating films comprises an organic material.

4. A light emitting device according to claims 1, wherein at least one of the first and the second interlayer insulating films comprises an inorganic material.

5. A light emitting device according to claim 1, wherein at least one of the first and the second interlayer insulating films comprises a film including siloxane moiety.

6. A light emitting device according to claim 3, wherein the organic material is acrylic.

7. A light emitting device according to claim 3, wherein the organic material is polyimide.

8. A light emitting device according to claim 1, wherein the light emitting device is incorporated into an electronic device selected from the group consisting of a display device, a camera, a computer, a portable information terminal, and a game apparatus.

9. A light emitting device according to claim 1, wherein said side surface of said second interlayer insulating film covers said side surface of said first insulating film.

10. A light emitting device according to claim 1, wherein said second protective film covers said first protective film.

11. A light emitting device comprising:

- a first substrate;
 - a first interlayer insulating film formed over the first substrate;
 - a source or drain electrode formed on the first interlayer insulating film;
 - a light emitting element formed over the first interlayer insulating film;
 - a second interlayer insulating film formed over the first interlayer insulating film; and
 - a second substrate provided over the light emitting element,
- wherein a first opening is formed in the first interlayer insulating film at a region in which the first and second substrates are fixed to each other with a sealing material, wherein the first opening is covered with a first protective film, wherein a side surface of the first protective film is covered with the second interlayer insulating film, wherein a second opening is formed in the second interlayer insulating film at the region, wherein the second opening is covered with a second protective film,
- wherein the second protective film is in contact with the second interlayer insulating film and is formed over the first protective film,

27

wherein a side surface of the first interlayer insulating film is tapered at the region,
 wherein the sealing material covers the side surface of the first interlayer insulating film and a side surface of the second interlayer insulating film at the region, and
 wherein the first protective film is the same material as the source or drain electrode.

12. A light emitting device according to the claim 11, wherein at least one of the first and the second protective films is impermeable.

13. A light emitting device according to claim 11, wherein the light emitting element is electrically connected to a thin film transistor.

14. A light emitting device according to claim 11, wherein at least one of the first and the second interlayer insulating films comprises an organic material.

15. A light emitting device according to claim 11, wherein at least one of the first and the second interlayer insulating films comprises an inorganic material.

28

16. A light emitting device according to claim 11, wherein at least one of the first and the second interlayer insulating films comprises a film including siloxane moiety.

17. A light emitting device according to claim 14, wherein the organic material is acrylic.

18. A light emitting device according to claim 14, wherein the organic material is polyimide.

19. A light emitting device according to claim 11, wherein the light emitting device is incorporated into an electronic device selected from the group consisting of a display device, a camera, a computer, a portable information terminal, and a game apparatus.

20. A light emitting device according to claim 11, wherein said side surface of said second interlayer insulating film covers said side surface of said first interlayer insulating film.

21. A light emitting device according to claim 11, wherein said second protective film covers said first protective film.

* * * * *

UNITED STATES PATENT AND TRADEMARK OFFICE
CERTIFICATE OF CORRECTION

PATENT NO. : 7,928,654 B2
APPLICATION NO. : 10/919605
DATED : April 19, 2011
INVENTOR(S) : Kaoru Tsuchiya et al.

Page 1 of 1

It is certified that error appears in the above-identified patent and that said Letters Patent is hereby corrected as shown below:

Column 6, Line 56, Change "IA" to --1A--.

Column 6, Line 59, Change "413" to --4B--.

Column 7, Line 1, Change "413" to --4B--.

Column 12, Line 57, Remove second occurrence of the word "is".

Column 17, Line 38, Remove the word "lo".

Column 17, Line 60, Remove the word "30".

Column 20, Line 35, Change "181" to --18I--.

Column 26, Claim 8, Line 35, Change "infoimation" to --information--.

Column 26, Claim 11, Line 54 Change "Ruined" to --formed--.

Signed and Sealed this
Twenty-sixth Day of June, 2012

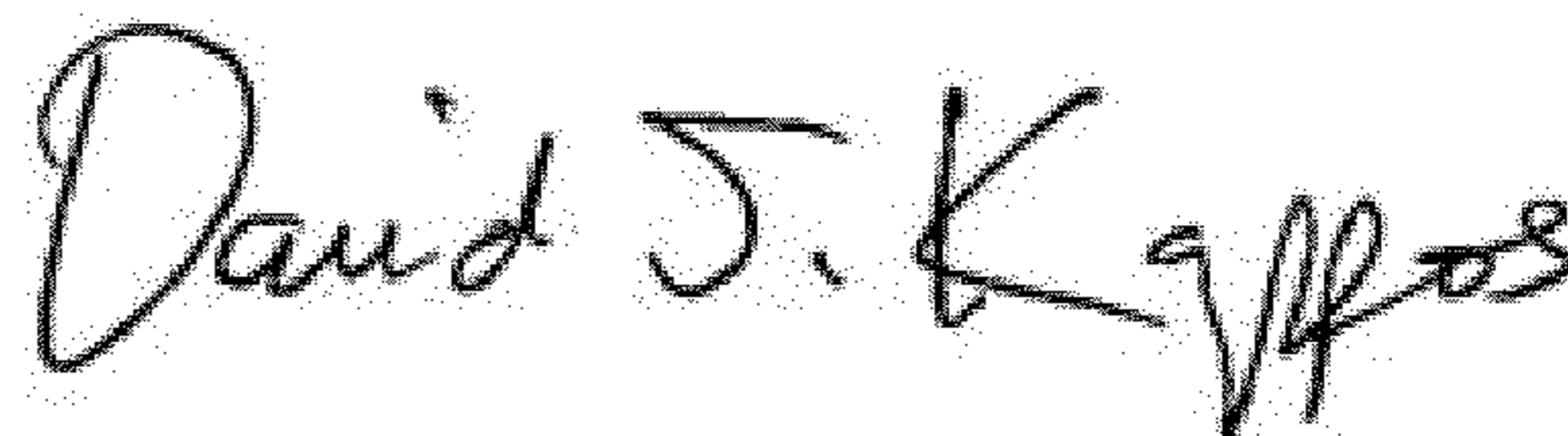

David J. Kappos
Director of the United States Patent and Trademark Office