



US007926492B2

(12) **United States Patent**
Hurwitz

(10) **Patent No.:** **US 7,926,492 B2**
(45) **Date of Patent:** ***Apr. 19, 2011**

(54) **DIRECT APPLICATION HORSE AND LIVESTOCK BRUSH HAVING FLOW REGULATOR ASSEMBLY**

(75) Inventor: **Marni Markell Hurwitz**, Far Hills, NJ (US)

(73) Assignee: **I Did It Inc.**, Fox Hills, NJ (US)

(*) Notice: Subject to any disclaimer, the term of this patent is extended or adjusted under 35 U.S.C. 154(b) by 656 days.

This patent is subject to a terminal disclaimer.

(21) Appl. No.: **11/880,249**

(22) Filed: **Jul. 20, 2007**

(65) **Prior Publication Data**

US 2007/0261643 A1 Nov. 15, 2007

Related U.S. Application Data

(63) Continuation-in-part of application No. 11/710,848, filed on Feb. 26, 2007, now Pat. No. 7,694,687, which is a continuation-in-part of application No. 11/349,638, filed on Feb. 8, 2006, now Pat. No. 7,322,364, which is a continuation-in-part of application No. 11/186,583, filed on Jul. 21, 2005, now Pat. No. 7,337,784.

(51) **Int. Cl.**
A45D 24/22 (2006.01)

(52) **U.S. Cl.** **132/112; 132/114; 132/113**

(58) **Field of Classification Search** **132/112-116; 401/184, 151, 185**

See application file for complete search history.

(56) **References Cited**

U.S. PATENT DOCUMENTS

1,501,089	A *	7/1924	Andrews	401/28
2,162,907	A *	6/1939	Bambach	401/28
4,244,076	A	1/1981	Meyer	15/188
4,552,477	A *	11/1985	Braithwaite et al.	401/188 R
5,150,491	A	9/1992	Ikemoto	15/1.52
5,195,545	A *	3/1993	Thibodeaux	132/116
5,261,426	A	11/1993	Kellett et al.	132/108
5,626,099	A	5/1997	Staller et al.	119/625
5,632,289	A *	5/1997	Sharp	132/116
5,762,433	A *	6/1998	Cary	401/184
6,244,273	B1 *	6/2001	Higgins	132/114
6,450,127	B2	9/2002	Willinger et al.	119/663
6,543,388	B2	4/2003	Willinger et al.	119/663
6,575,174	B2	6/2003	Lee	132/160
7,322,364	B2 *	1/2008	Hurwitz	132/116
7,337,784	B2 *	3/2008	Hurwitz	132/116

* cited by examiner

Primary Examiner — Robyn Doan

(74) *Attorney, Agent, or Firm* — Ernest D. Buff & Associates, LLC; Margaret A. LaCroix; Ernest D. Buff

(57) **ABSTRACT**

A horse and/or livestock brush assembly releases a fluid and/or liquid solution directly onto the coat of an animal during brushing. The brush assembly includes a brush base attached to a hose and flow regulator. The brush base comprises a flexible deformable membrane with a plurality of apertures that are, optionally, aligned with apertures in brush bristles for delivery of the fluid and/or liquid solution, and is fitted within a first opening of an internal cavity in a brush base. Delivery of the fluid or liquid solution is controlled by way of the flow regulator. An optional mixing chamber housing a water soluble compound containing active ingredients may be attached to the flow regulator to form a liquid solution. The liquid solution includes perfumes, fragrances and other active compositions including insect repellent, hair conditioners, dyes, moisturizers, or antibacterial compounds. The fluid and/liquid is delivered directly to the animal's fur or hair while brushing the coat.

21 Claims, 6 Drawing Sheets

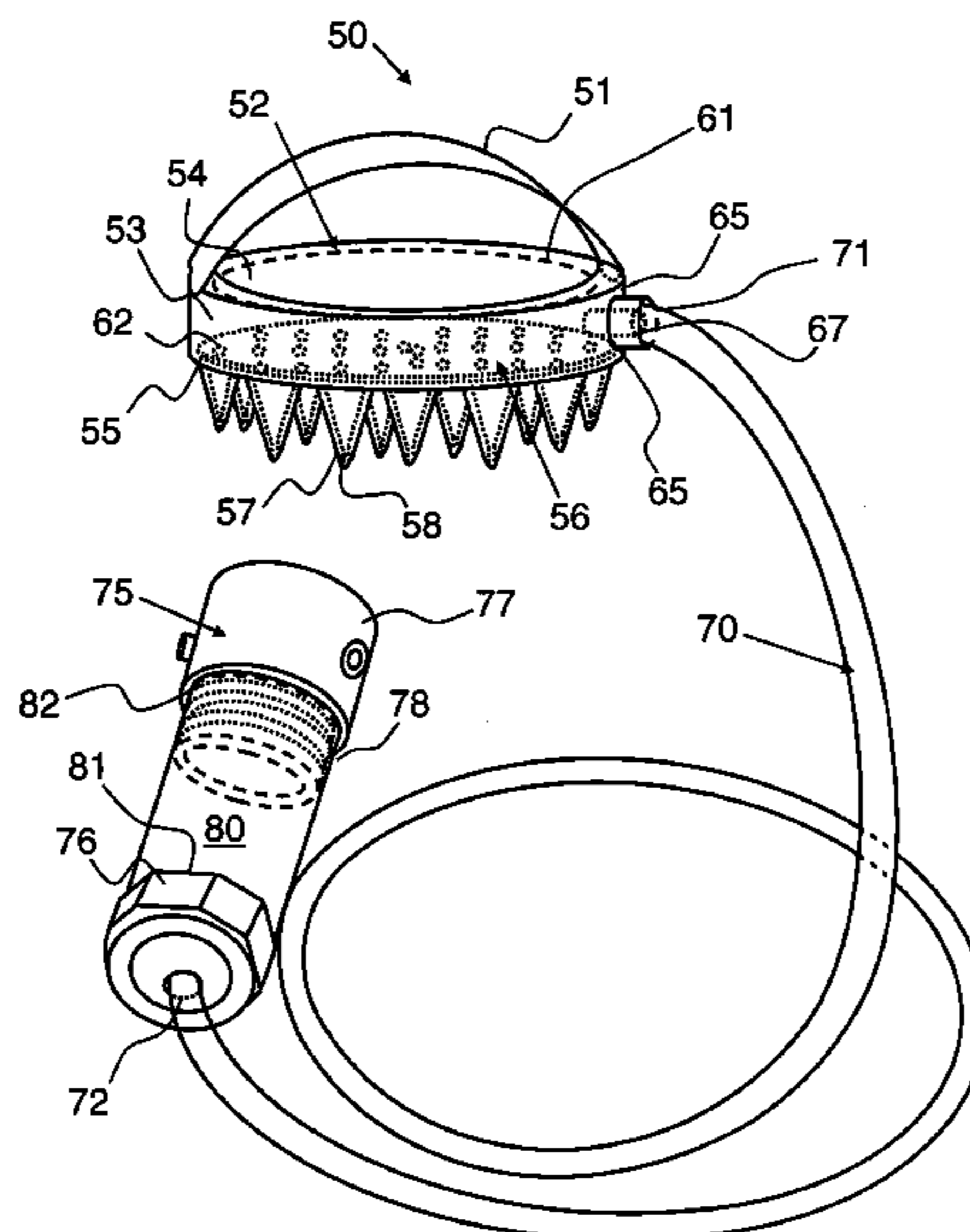
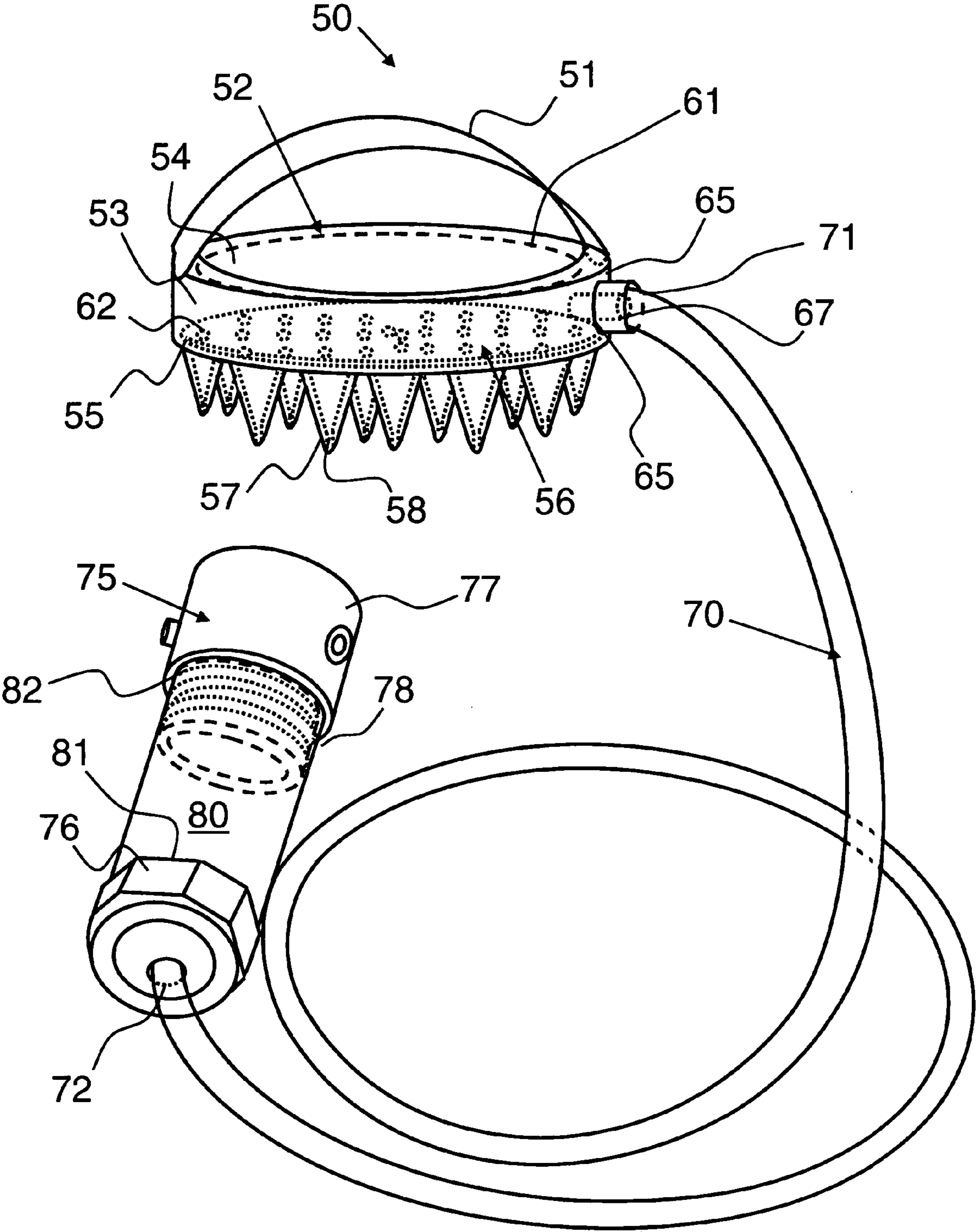

Fig. 1



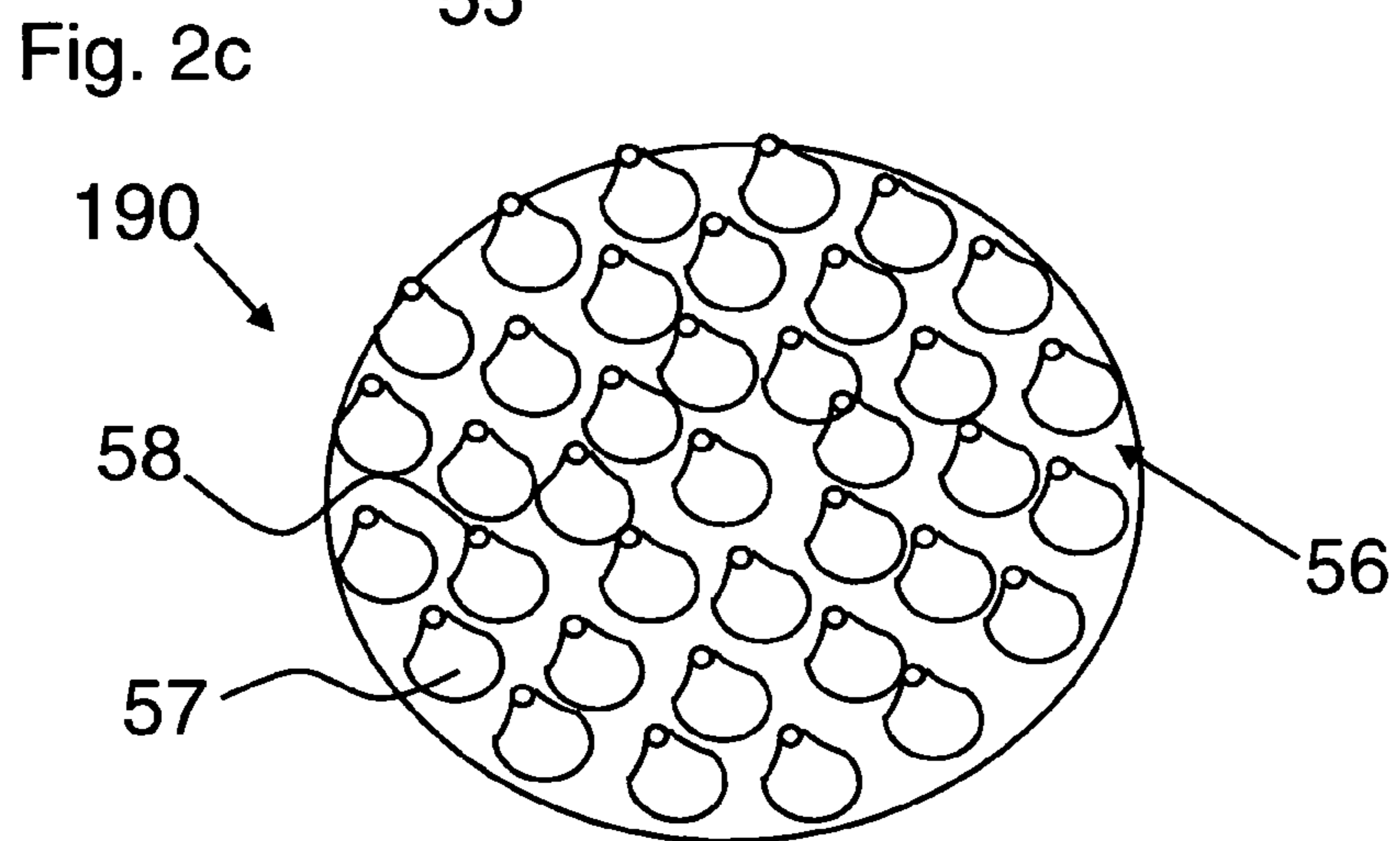
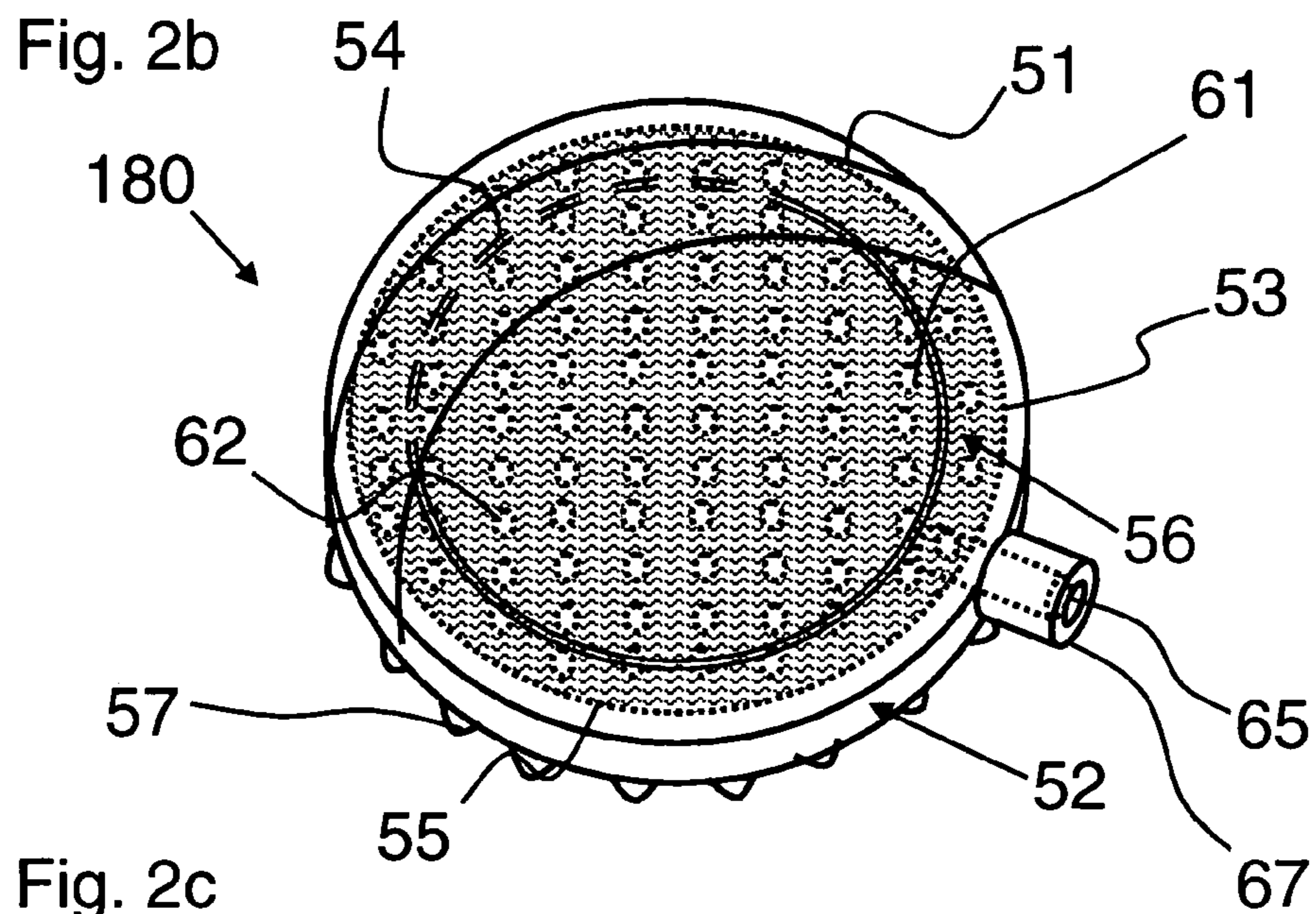
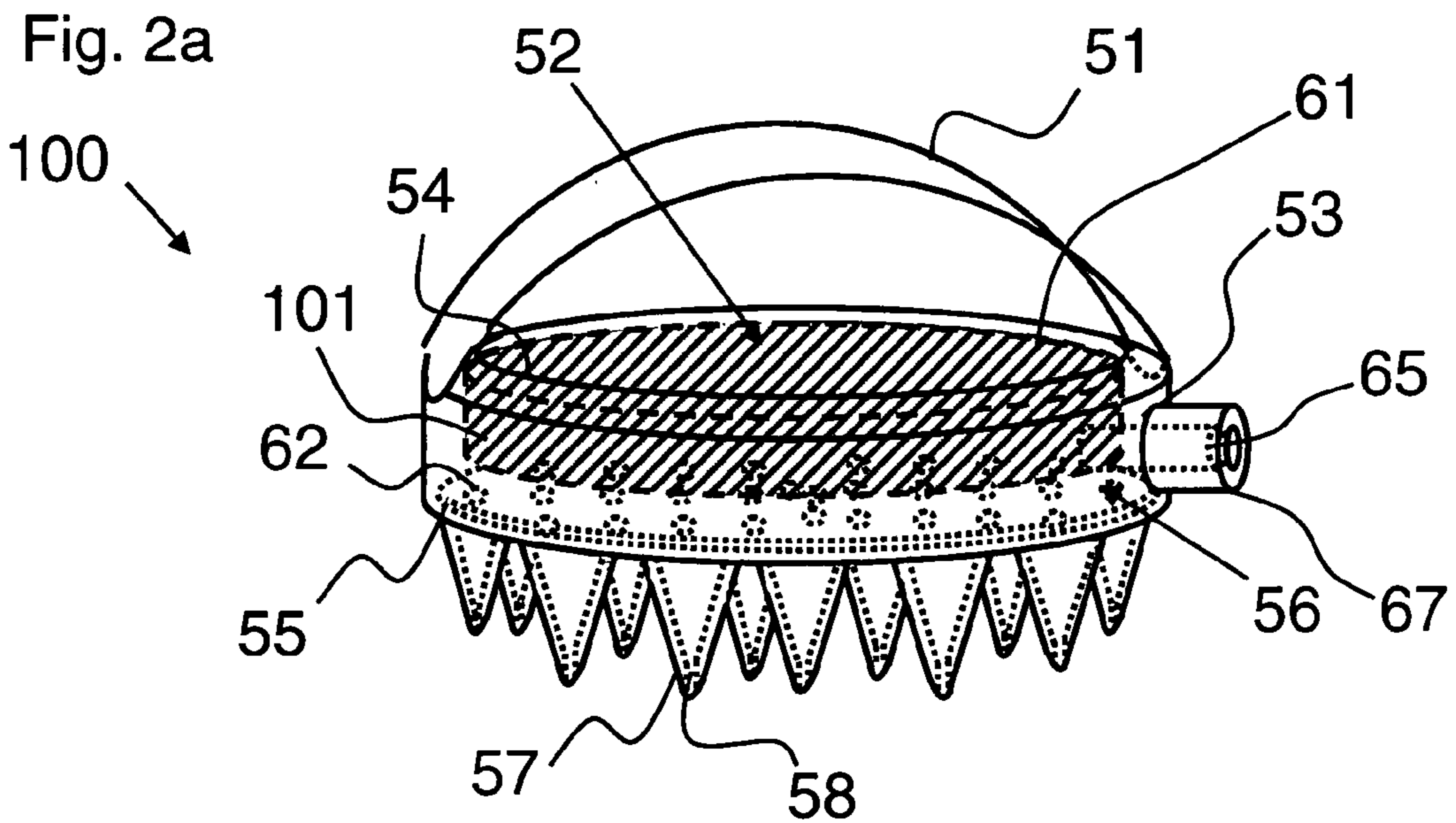

Fig. 3

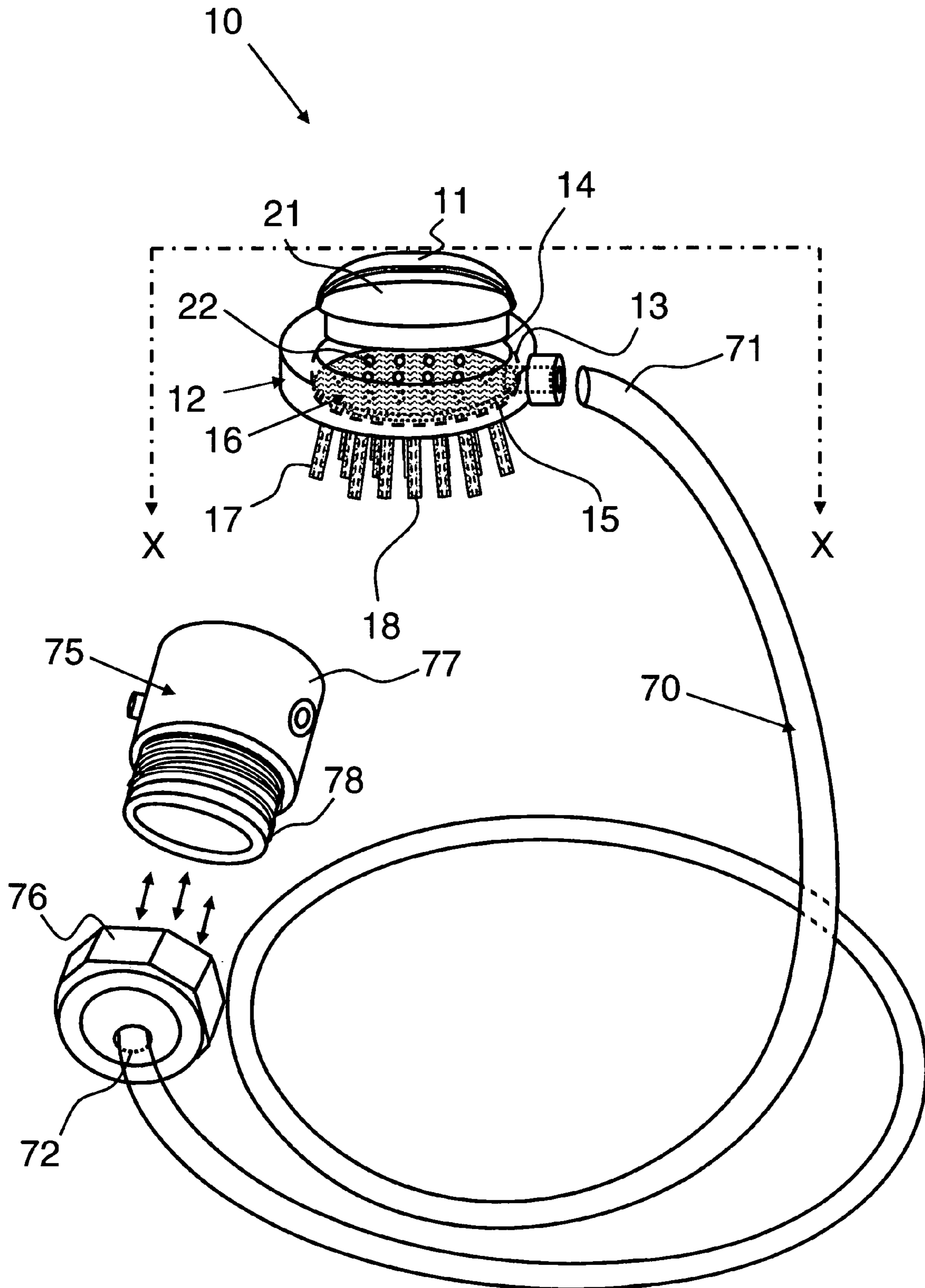

Fig. 4

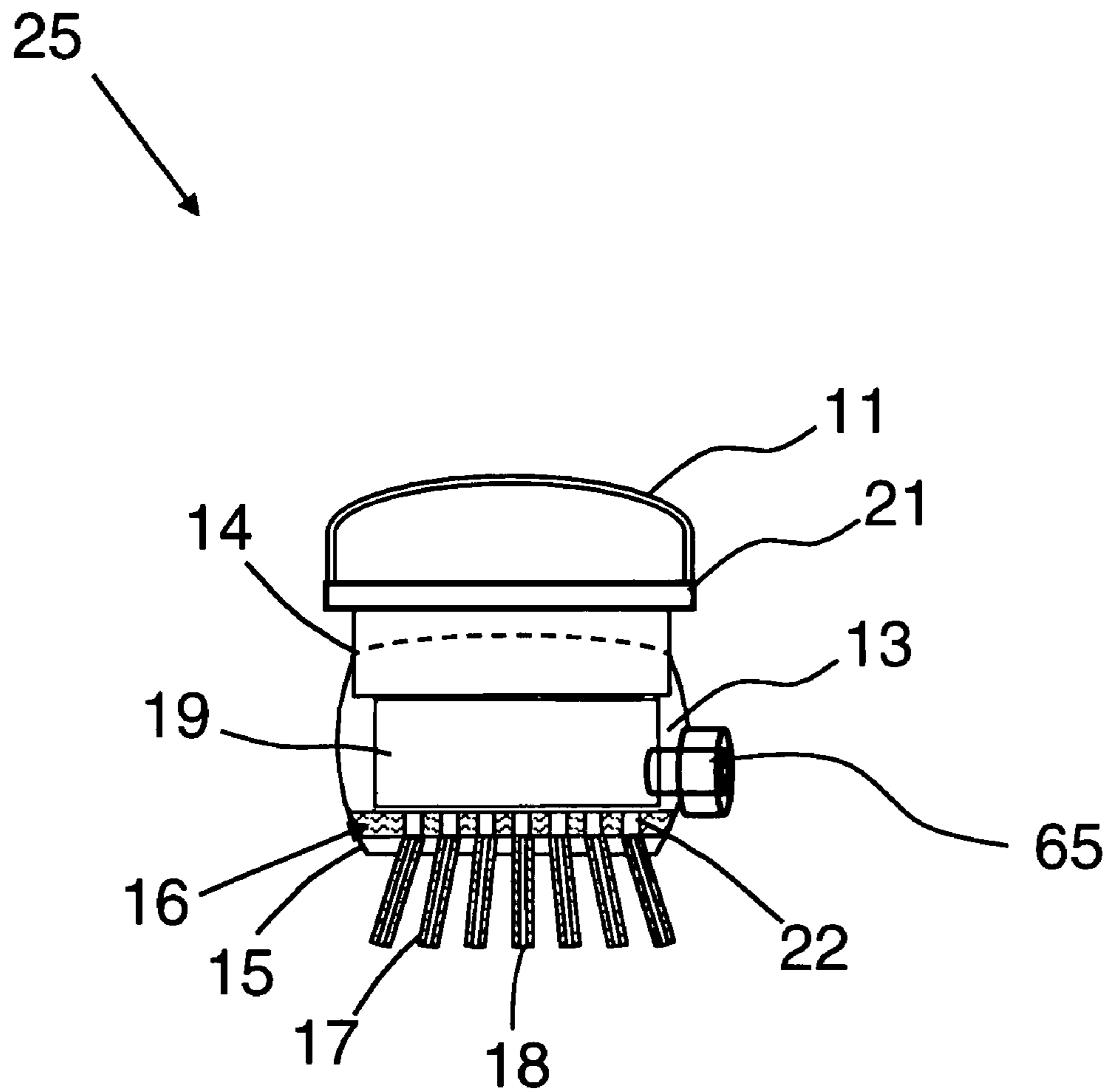

Fig. 5a

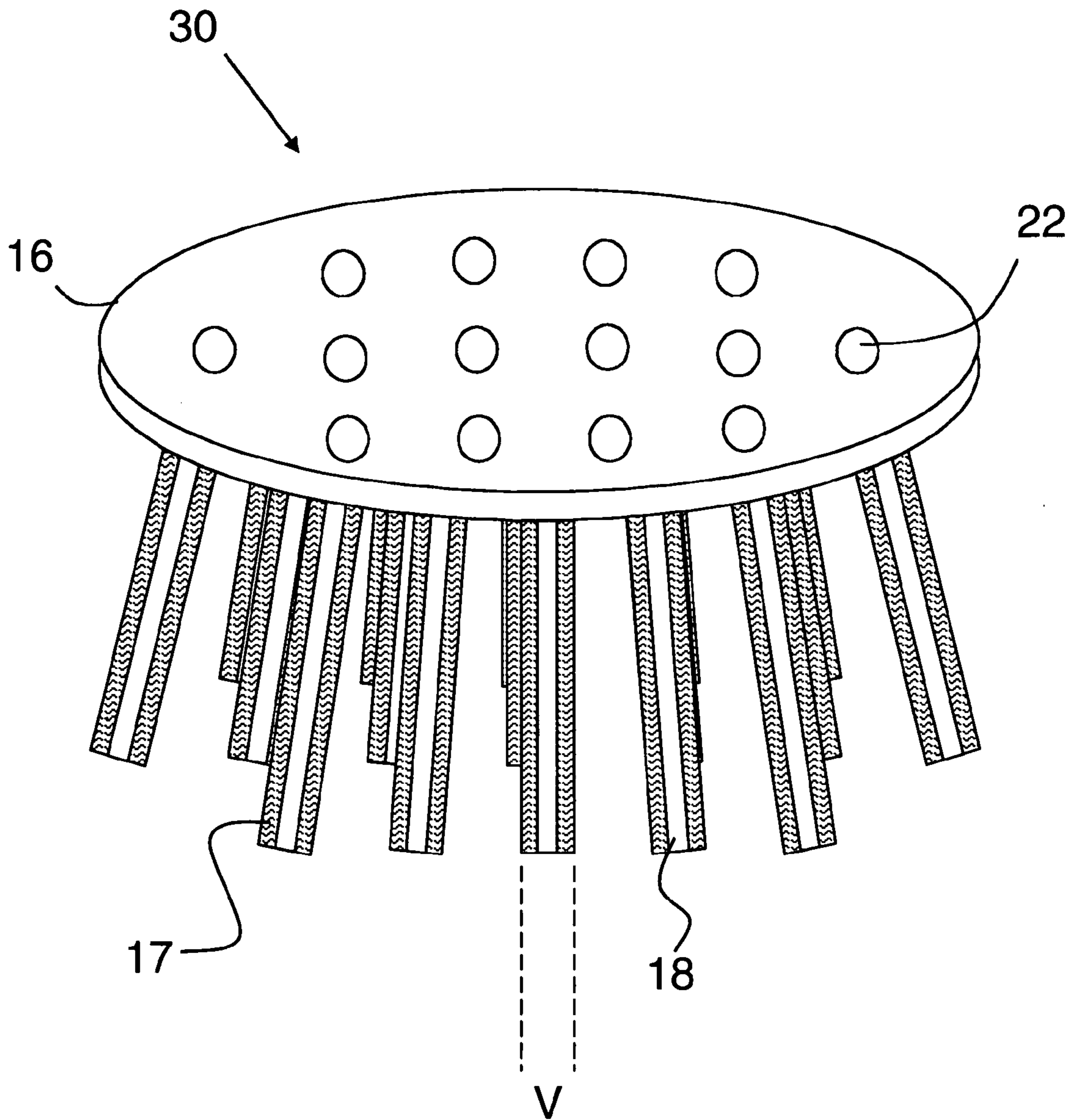

Fig. 5b

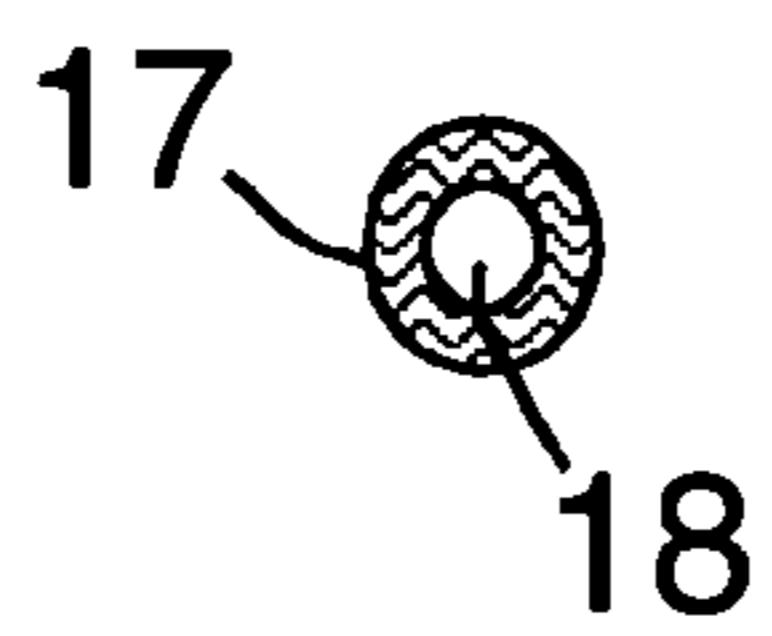

Fig. 6a

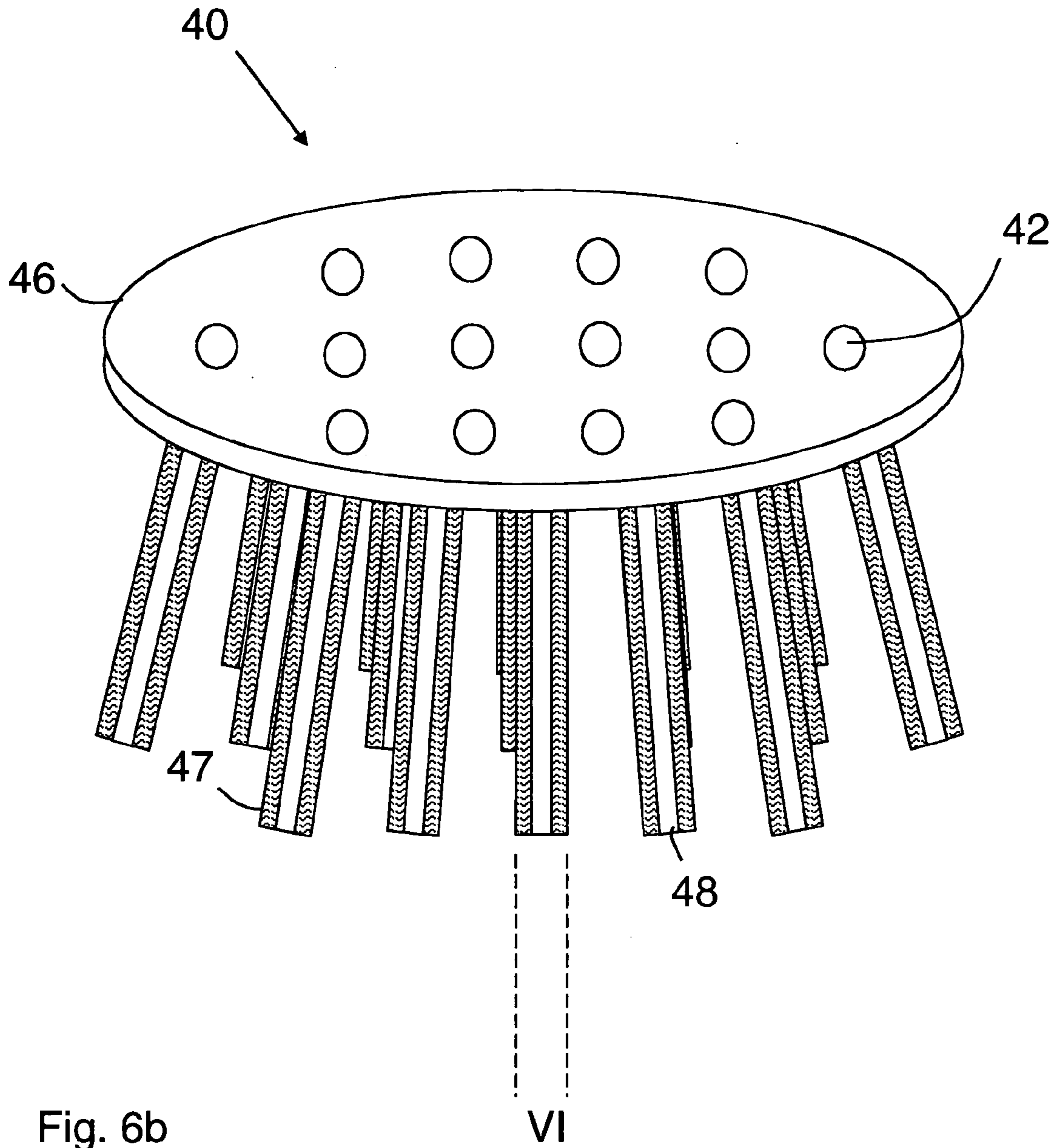
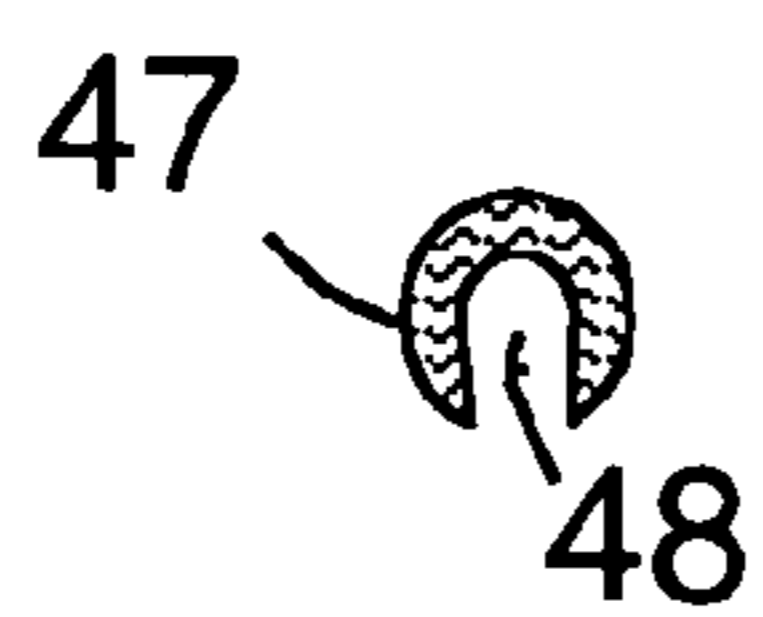

Fig. 6b



DIRECT APPLICATION HORSE AND LIVESTOCK BRUSH HAVING FLOW REGULATOR ASSEMBLY

This is a Continuation-In-Part of application Ser. No. 11/710,848, filed Feb. 26, 2007, now U.S. Pat. No. 7,694,687 for "Direct Application Brush For Horses and Livestock That Releases Active Ingredients" which, in turn, is a Continuation-In-Part of application Ser. No. 11/349,638, filed Feb. 8, 2006, now U.S. Pat. No. 7,322,364 for "Hairbrush for Pets and People that Releases Active Ingredients", which, in turn, is a Continuation-In-Part of application Ser. No. 11/186,583, filed Jul. 21, 2005, now U.S. Pat. No. 7,337,784 for "Hairbrush for Pets and People that Releases Active Ingredients", the disclosures of which are hereby incorporated in their entirety by reference thereto.

BACKGROUND OF THE INVENTION

1. Field of the Invention

The present invention relates to a direct application brush assembly for horses and livestock that is appointed with a flow regulator and lightweight hose for fluid delivery onto fur or hair; and more specifically to a brush assembly which, during brushing, releases fluid fed through a hose associated with a flow regulator that is, optionally, attached to a mixing chamber containing a compound having active ingredients soluble in water to form a liquid solution appointed to be delivered through the hose into the brush and released into the fur or hair. Active ingredients delivered through the liquid solution include therapeutic or moisturizing compounds, antibacterial compounds, insect repellent, flea and/or tick compounds, hair-conditioning and detangle products, sun protection lotions, mane and tail whiteners and stain removers, dye compositions, fragrances or other hair-related products.

2. Description of the Prior Art

Many patents address issues related to brush designs having a number of bristles adapted to provide desired brushing action. Brushes for pets, horses and livestock typically incorporate harsh bristles, while those for humans are typically provided with softer bristles. Several patents disclose coating bristles with desired compositions in order to deliver these compositions to the brushed hair.

U.S. Pat. No. 4,244,076 to Meyer discloses a method and forming tool for the fabrication of a bristle support for a brush, especially a hairbrush. The method involves attaching pin-like bristles to a bristle support or carrier for a hairbrush. In a first step the rows of bristle pins are interconnected with one another at their rear end by means of a web. The individual bristle pin rows are retained in their position by the web. In a next step the bristle pins, at the region of their rear ends, together with the webs, are cast in the material of the bristle support, so that the bristle pin rows are embedded in the bristle support. In this method, the bristle pins are molded into a cast support that is rigid and solid and therefore is incapable of delivering perfume or other active compositions to the hair or fur being brushed.

U.S. Pat. No. 5,150,491 to Ikemoto discloses a hairbrush adapted to prevent static charging of the bristles and hair. It has a multiplicity of small holes formed in a conductive brush base that carries a row of antistatic members. The antistatic members are relatively stiff. They are prevented from bending down, and render the brush easy to draw through hair, thereby facilitating smooth brushing. The conductive brush base is solid. It cannot deliver perfume or other active compositions to hair or fur, but merely eliminates the static present in the hair and bristles by conducting charges that are present.

U.S. Pat. No. 5,261,426 to Kellett, et al. discloses a hydrophilic foam pad for hair styling. The hair conditioning and styling pad has a shaped body of a resilient, open-celled, hydrophilic polyurethane foam matrix integrally incorporating an aqueous phase incorporating about 70-90% water, about 5-25% of a hair conditioning agent, and a nonionic surfactant. The bristles or tines of a brush contact the resilient pad and transfer the aqueous hair styling composition to the brush so that the composition is subsequently transferred to the hair as it is being styled. This styling device requires periodic contact with the resilient pad to recharge the bristles, and does not by itself deliver perfume or other active compositions to hair or fur.

U.S. Pat. No. 5,626,099 to Staller, et al. discloses a therapeutic groomer. This hand-held grooming device grooms, massages, and provides magnetic therapy for animals. The device has a base that is configured to be hand-held. On the base, there is formed a grooming pad having projections adapted for grooming and massaging. The grooming pads are formed by either a plurality of parallelly arranged strips, each having magnetic properties, or a single magnetic sheet. Each strip has its magnetic poles aligned uniformly so that its longitudinal ends are polar opposites. The therapeutic groomer does not deliver perfume or active compositions to the hair or fur being groomed.

U.S. Pat. Nos. 6,450,127 and 6,543,388 to Willinger, et al. disclose an ergonomic handle for a grooming brush. This brush handle is formed with a continuously arched upper surface portion and a lower surface portion separated by a humped semicircular ridge. One of the lower arched portions forms a trigger grip for a single finger held in either a forehand or backhand grip. The handle is covered with a high friction material in the form of a contoured rubber or elastomeric sleeve, which is stretched over a molded plastic handle. These patents relate only to the shape of a handle of a hairbrush and do not disclose a brush that delivers perfumes or other active ingredients to brushed hair or fur by way of flow regulation of fluid fed into a cavity within the brush.

A hairbrush commercially marketed by JW Pet Company (Hasbrouck Heights, N.J.) incorporates an ergonomic handle disclosed in U.S. Pat. Nos. 6,450,127 and 6,543,388. It uses a polymeric molded closed elliptical cavity which includes a thick elliptical rubber element carrying multitudes of metallic bristle pins with rounded tips. The distal end of the bristle pins opposed to the rounded tips carries nail heads, which rests against and are glued to a thick rubber element using rubber cement or similar glue. The bristle pins in the rubber element form an air leak-tight seal. The elliptical rubber element has a single hole appointed for discharging air. This elliptical rubber element with attached pins is squeezed into the closed elliptical cavity of a polymeric molded brush and the rubber element adopts a concave shape with the pins sticking out in a non-planar configuration. During use, pressure is applied to the pins in the middle portion of the elliptical rubber element of the brush. The air entrapped in the cavity formed by the rubber element and elliptical cavity is squeezed by the pressure applied, thereby providing a springy feel, while the entrapped air is released through the single hole present in the elliptical rubber element. This brush has a single air outlet and discharges air entrapped in the elliptical cavity of the brush. It has no means available for delivering a perfume or other active ingredients to the brushed hair or fur.

U.S. Pat. No. 6,575,174 to Lee discloses a hair grooming brush having a plurality of rows of curved wavy bristles, rather than traditional straight bristles commonly found on brushes and combs. The curvature of the bristles produces springiness to the bristles when pressure is applied during the

3

combing action. The springiness of the numerous rows of bristles translates into a massaging effect upon the hair and scalp. These springy bristles do not deliver perfumes or other active compositions to the hair or fur being brushed.

There remains a need in the art for an easy to use brush assembly for grooming horses and livestock that continuously delivers fluid directly to the hair, mane, and fur. Specifically, there is a need in the art for a brush assembly providing a brush base fitted with a flexible hose attached to a flow regulator for controlled fluid delivery. Also, there remains a need in the art for a brush assembly that can be connected to a mixing chamber to form a liquid solution containing active ingredients, including one or more active ingredients, such as perfume or other active compositions, appointed to be continuously delivered to the hair, mane, and fur of these animals.

SUMMARY OF THE INVENTION

The present invention discloses a lightweight brush assembly having a brush base appointed with a hose and a flow regulator for controlled delivery of a fluid or liquid solution directly to an animal's fur. The brush base includes an internal cavity with a bottom surface having a first opening, a top surface having a second opening, and an orifice for delivery of the fluid into the internal cavity from the hose. The first cavity opening is located on the bottom surface of the brush base, facing the bristles of the brush. The second cavity opening is located on the top surface of the brush base, opposed to the bristles. A flexible, deformable membrane having a plurality of apertures, preferably made from rubber, carries a multitude of bristles inserted through the apertures in the flexible deformable membrane. Each bristle is provided with a central aperture and optionally a slit along the length of the bristle. The central aperture is aligned with the aperture in the flexible deformable membrane so that a continuous liquid gel delivery path is provided. The edges of the flexible deformable membrane are tightly fitted to or permanently bonded to the walls of the first opening of the internal cavity, thereby forming a substantially leak tight seal. The second cavity opening is fitted with a back cover. The flow regulator is attached to a first end of a hose, while a second end of the hose is attached to the orifice of the brush base so that the hose delivers a fluid from the flow regulator into the internal cavity of the brush base; The flow regulator controls delivery of the fluid into the hose and, consequently, the internal cavity of the brush base when brushing the fur or hair, releasing the fluid through the apertures in the flexible deformable membrane and the bristles onto the fur or hair. Optionally, a mixing chamber may be attached to the flow regulator, wherein the mixing chamber houses a soluble compound with an active composition which dissolves in water delivered from the flow regulator to form a liquid solution that is fed into the brush base. The liquid solution contains a desired liquid gel of perfume or fragrance or other active compositions such as insect repellants, hair-conditioning products, dye compositions, moisturizing ingredients, antibacterial compounds, and the like. When hair or fur is brushed with the brush of the subject invention, the flow regulator is turned on and adjusted according to the desired flow rate and the fluid and/or liquid solution containing fragrance or perfume or other active composition is released to the hairs or fur of the coat being brushed through the fine apertures provided within the bristles transferring the liquid gel perfume, fragrance or active ingredient to hairs or fur of the coat during brushing.

The bristles with fine apertures may be attached to the flexible deformable membrane apertures in numerous ways.

4

The bristles may be molded together by injection molding or similar processes with the deformable membrane, as a unitary body with the apertures in the flexible deformable membrane matching the central aperture in the bristle. In a second embodiment, the bristles may comprise apertures that are U shaped so that the aperture not only brings the liquid gel perfume, fragrance or active agent to the tip of the bristle, but also delivers along the length of the bristle. In this embodiment, the bristles deliver the fluid and/or liquid solution containing perfume, fragrance or active ingredient along its entire length and any hairs or fur of the coat contacting the bristle is coated with the liquid gel of fragrance, perfume or active ingredient.

The brush is assembled first by inserting the flexible, deformable membrane with brush elements having fine apertures attached thereto into the first opening of the internal cavity of the brush base. The deformable membrane is entirely contained within the first opening, wherein the perimeter of the membrane rests against the inner wall which is defined by the internal cavity. Next, the hose and flow regulator are connected to the orifice of the brush base for delivery of the fluid into the internal cavity of the brush base. During application, the fluid is delivered to the brush base and through the bristle apertures.

The liquid perfume, fragrance or active ingredient has a contact angle sufficiently low, typically in the range of 1 to 30 degrees with respect to the bristle material so that the liquid penetrates the fine apertures provided within the bristles. If the contact angle is significantly larger, the penetration of the liquid gel within the fine apertures of the bristle is compromised.

Significant advantages are realized by practice of the present invention. The key features of the direct application horse brush assembly, include, in combination, the features set forth below:

- 1) a brush base having an internal cavity with a bottom surface that has a first opening and top surface that has a second opening, respectively;
- 2) the first opening being appointed to receive a flexible deformable membrane;
- 3) the second opening being appointed to receive a back cover;
- 3) the flexible deformable membrane having several rows of bristle elements with fine apertures provided therein;
- 4) optionally, a porous sponge or soluble disk saturated with a water soluble formulation of fragrance, perfume and/or other active composition may be inserted from the second opening in the internal cavity of the brush base. The optional porous sponge is arranged so that it rests on the flexible deformable membrane, feeding a sponge liquid solution to the aperture in the flexible deformable membrane and central apertures in the bristles as water or fluid from the hose and, consequently, a vie flow regulator are delivered into the internal cavity of the brush base to dissolve and mix with the water soluble formulation saturated within the porous sponge;
- 5) a second end of a hose is connected to the orifice of the brush base, and a first end of the hose is connected to a flow regulator for controlled delivery of a fluid into the internal cavity of the brush base;
- 6) optionally, a mixing chamber containing a substantially water soluble compound that has an active ingredient may be attached to the flow regulator so that as water

5

travels through the flow regulator into the mixing chamber the compound is dissolved to form a liquid solution; and

- 7) the user may periodically replace the optional mixing chamber with a fresh mixing chamber when the perfume, fragrance and/or other active composition is exhausted;

whereby the user of the brush of the subject invention is provided with the capability to saturate the hairs or fur of the coat being brushed with water, a perfume, fragrance and/or other active compositions including insect repellent, hair conditioning products, dye compositions, moisturizing ingredients, antibacterial compounds, and the like.

BRIEF DESCRIPTION OF THE DRAWING

The invention will be more fully understood and further advantages will become apparent when reference is had to the following detailed description of the preferred embodiments of the invention and the accompanying drawings, in which:

FIG. 1 is a schematic view of an embodiment of the brush assembly of this invention, showing the brush base with the internal cavity therein, the flexible deformable membrane having brush elements with a central aperture and the orifice being attached to the hose which, in turn, is attached to a flow regulator equipped with an optional mixing chamber;

FIG. 2a is a side view depicting the brush base of this invention, showing the internal cavity, the flexible deformable membrane having brush elements with a central aperture, the back cover, the handle, and the side wall having the orifice for attachment to the hose and flow regulator, so that the optional porous sponge or soluble disk can be inserted into the internal cavity;

FIG. 2b is a top plane view of the brush base of this invention depicted in FIG. 2a;

FIG. 2c is a bottom plane view of the brush base of this invention showing the flexible deformable membrane having apertures aligned with bristle apertures depicted in FIG. 2a;

FIG. 3 is an illustration depicting the brush base of this invention, showing the internal cavity, the flexible deformable membrane having brush elements with a central aperture, the back cover and the side wall having an orifice designed for attachment to the hose and flow regulator;

FIG. 4 is a cross section of the assembled brush of the subject invention taken along cross section XX of FIG. 3, showing the relative locations of the flexible deformable membrane with attached bristles having a central aperture, the back cover, and the side wall having an orifice designed for attachment to the hose and flow regulator;

FIG. 5a is an illustration showing the flexible deformable membrane with attached bristles having a central aperture according to the first embodiment of the invention;

FIG. 5b is a cross section of an individual bristle showing the central aperture;

FIG. 6a is an illustration showing the flexible deformable membrane with attached bristles having a central aperture and having additional aperture openings along the length of the bristle, according to the second embodiment of the invention; and

FIG. 6b is a cross sectional view of an individual bristle showing the U shaped central aperture.

DETAILED DESCRIPTION OF THE INVENTION

This invention relates to a brush and flow regulator with hose assembly for use with horses and livestock. The brush assembly of the subject invention releases fluid, such as

6

water, and/or a solution containing active compounds in substantially liquid form onto the fur, hair, mane, and coat of the horse or livestock animal, penetrating follicle depths. Fluid flow is controlled by the flow regulator, which feeds fluid into a hose that delivers the liquid into an internal cavity of a brush base for release through apertures in a flexible deformable membrane into aligned bristle apertures and onto the fur or hair. A mixing chamber housing an active substantially water soluble compound may be attached to the flow regulator to mix with water to form a liquid solution that is delivered into the brush base. Active ingredients delivered in the liquid solution include fragrances, therapeutic or moisturizing compounds, hair-conditioning and detangle products, sun protection lotions, mane and tail whiteners and stain removers, dye compositions and other hair-related products, antibacterial compounds, flea and/or tick compounds, and insect repellent or the like. Direct delivery of the active compound onto the coat and mane of the animal provides optimal penetration and effectiveness of the product's treatment. Upon exhaustion of the liquid solution, water may continuously pass through the flow regulator into the hose to flush the assembly as well as rinse and finish cleaning the animal.

The present brush assembly's application is particularly directed to use with livestock and barn animals such as horses, ponies, llamas, cattle and the like, as well as family pets such as dogs and cats. These animals are oftentimes exposed to infection through parasites, such as ticks, and would benefit from a brush assembly that provided a direct delivery system wherein medicament can be delivered quickly and efficiently to the animal's skin, without having to be rubbed in through the animal's coat. Direct delivery of the active ingredients of the product to the animal's skin and interstitials of the hair or fur of the coat provides optimal application without loss due to run-off from upper surface applications of the product. As a result, exposure and contact of the active ingredients to the individual applying same is mitigated, while the delivery of the active ingredients is achieved in a highly efficient manner.

The brush assembly includes a brush base attached to a hose and flow regulator. The brush base is provided with a bottom surface having a first opening, a top surface having a second opening, and at least one side wall constructed to form an internal cavity. The brush base further includes an orifice for attachment to the hose and flow regulator. This orifice is preferably located on the side wall, extending externally from the side wall into the internal cavity. The first opening receives a flexible deformable membrane which carries bristle elements having central apertures to release fluid or/and a liquid solution containing perfume, fragrance, and/or active compositions during brushing or at the desire of the user at any time through controlled delivery by way of the flow regulator. The flexible deformable membrane has a plurality of apertures within which bristles with central apertures are placed. Central apertures within the bristles provide a continuous fluid/liquid gel/solution flow path.

The first opening of the brush base receives the flexible deformable membrane with the bristles having a central aperture so that the bristles extend from the brush base. The perimeter of the flexible deformable membrane rests against the interior wall of the brush base defined by the internal cavity, thereby forming a substantially leak tight seal. Preferably, the flexible deformable membrane is permanently bonded to the walls of the first opening of the brush base. A back cover is inserted through the second opening to form a substantially leak tight seal for the internal cavity.

The flow regulator operates to flush fluid through the hose and into the brush base. Fluid preferably is water or an aqueous solution. A mixing chamber may be attached to the flow

7

regulator. This mixing chamber preferably contains a water soluble compound comprised of active ingredients. Water from the flow regulator is mixed with the compound within the mixing chamber to form a liquid solution, which is then delivered through the hose into the internal cavity of the brush base, and onto the animal's coat. Upon exhaustion of the liquid solution the brush may be removed from the animal, or water may continue to flow through the hose to rinse the solution from the animal, such as if the liquid solution is a shampoo or soap solution. Generally stated, the invention consists of a brush base which releases fluid and/or liquid solution containing fragrance, perfume and/or other active compositions during brushing via a flow regulator. During the brushing action the flow regulator is activated and fluid flows through the hose into the orifice and into the internal cavity to be delivered through the apertures of the bristles integrated within the flexible deformable membrane.

The first opening may take any shape including elliptical, circular, rectangular, or square-shaped. The second opening may take any shape including elliptical, circular, rectangular, or square-shaped. The flexible, deformable membrane may take any shape including elliptical, circular, rectangular, or square-shaped. The back cover may take any shape including elliptical, circular, rectangular, or square-shaped. Any other suitable geometric shapes are within the scope of the present invention. Preferably, each of the first opening, second opening, flexible membrane, and back cover has the same general shape, respectively. At a minimum, all that is required is that, whatever its shape, the flexible deformable membrane and the cover form a substantially air tight seal with the internal cavity so that the fluid and/or liquid solution with perfume, fragrance and/or other active composition is released reliably.

The flexible deformable membrane is preferably made from rubber, typically with a thickness of $\frac{1}{32}$ inch to $\frac{3}{32}$ inch. The apertures provided for receiving the bristles are typically 0.010-0.60 inches, matching the outer diameter of the bristles used. The bristles are preferably polymeric bodies with a central aperture and a rounded end contacting hair. The bristles have a diameter ranging from 0.010 inch to 0.060 inches with central apertures having a diameter ranging from 0.005 inch to 0.040 inches. The bristles with a central aperture are preferably permanently bonded to the flexible deformable membrane apertures using glue or other attachment means, with the central aperture in the bristle matching that in the flexible deformable membrane so that a continuous liquid gel flow path is provided. Alternatively, the flexible deformable membrane and the bristles with the central aperture may be molded by an injection molding process in one step to create a one piece unit which contains both the flexible deformable membrane and the bristles with central aperture.

In the second embodiment of the invention, each of the bristles not only has a central opening, but has a slit aperture along the length of the bristle. In other words, the bristle is U-shaped in its cross section and fits into or is bonded to the aperture in the flexible deformable membrane. In this arrangement, the fluid and/or liquid solution is delivered to the hair that is being brushed both along the length of the bristle and its tip, providing more uniform distribution of the fluid and/liquid solution into the animal's coat.

Since the fluid and/or liquid solution has to travel along the length of the bristle through the central aperture, it is important that the contact angle of the fluid and/or liquid solution with the bristle be in the range of 2 degrees to 30 degrees. If the contact angle exceeds this range, the fluid and/or gel/liquid solution may not easily penetrate the central aperture

8

and be delivered to the tip of the bristle in the first embodiment or to the tip and side surface of the bristle in the second embodiment.

Assembly of the brush of this invention comprises the steps of:

1. Arranging a flexible deformable membrane with a plurality of apertures adapted to receive and be attached to bristles with central apertures. The flexible deformable membrane is inserted through the first opening in the internal cavity of the brush base. Since the flexible deformable membrane has a slightly larger dimension than the first opening in the brush base, it must be flexed to insert the flexible deformable membrane. At this stage, the bristles with central aperture incorporated in the flexible deformable membrane point away from the internal cavity of the brush base. The perimeter of the flexible deformable membrane rests against the interior walls defined by the internal cavity, thereby forming an airtight seal. Alternatively, the flexible deformable membrane with attached bristles having a central aperture may be permanently bonded to the brush base.
2. Optionally, a porous sponge or soluble disk saturated with a water soluble formulation of fragrance, perfume and/or other active composition may be inserted from the second opening in the internal cavity of the brush base. The optional porous sponge is arranged so that it rests on the flexible deformable membrane, feeding a sponge liquid solution to the aperture in the flexible deformable membrane and central apertures in the bristles as water or fluid from the hose and, consequently, the flow regulator are delivered into the internal cavity of the brush base to dissolve and mix with the water soluble formulation saturated within the porous sponge.
3. The back cover is inserted over the second opening. This is a sliding fit providing a leak tight seal.
4. A second end of a hose is connected to the orifice of the brush base, and a first end of the hose is connected to a flow regulator for delivery of a fluid into the internal cavity of the brush base.
5. Optionally, a mixing chamber containing a substantially water soluble compound having an active ingredient may be attached to the flow regulator so that as water travels through the flow regulator into the mixing chamber the compound is dissolved to form a liquid solution.
6. Now the assembled brush is ready to use. It delivers fluid and/or the liquid solution with active ingredients, such as perfume, fragrance and/or other active compositions, when the brush is used to brush human or pet hair or livestock. Once the liquid solution perfume, fragrance and/or active composition is exhausted, water may continue to run through the flow regulator and hose into the brush base and onto the animal's fur or hair to rinse any solution off of the animal's coat. Upon exhaustion of the compound in the mixing chamber, the mixing chamber is removed and re-filled or replaced with a new mixing chamber.

Plastic materials have particular application in manufacturing the subject brush assembly, specifically including polyvinyl chloride (PVC) and acrylonitrile butadiene styrene (ABS). The size of the channel-like openings in the bristles could vary depending upon the viscosity of the liquid composition appointed for delivery. A vast array of animal health care products, soaps, shampoos, compounds and solutions can be applied through use of the subject brush, such as those set forth in Table I hereinbelow.

TABLE I

Animal Care Product	Function
ULTRASHIELD™	Insecticide & Repellent
SUPERSHIELD RED™	Water-Resistant Fly Repellent
SUPERSHIELD GREEN™	Horse Spray, Herbal Gel & Super Concentrate
SHOWSHEEN™	Hair Polish & Detangler
ULTRASCREEN™	Maximum Sun Protection Lotion & Fade Protection
SUPERPOO & SHOWCLEAN™	Mane & Tail Whitener & Stain Remover
ABSORBINE®	Varying Application; muscle, joint and arthritis pain reliever;

FIG. 1 illustrates a schematic view of an embodiment of the brush assembly of this invention, shown generally at 50. In the embodiment shown, the optional mixing chamber is attached to the flow regulator. Brush assembly 50 includes a handle 51 and brush base 52 having an internal cavity 53. The internal cavity 53 has a first opening 55 and a second opening 54. A flexible deformable membrane 56 with bristle elements 57 having apertures 58 is inserted within the first elliptical opening 55. Bristles elements 57 are herein shown having a cone shape, but bristle elements 57 may have an elongated rectangular or cylindrical shape (as is illustrated in FIGS. 3-6 hereinafter), or any suitable shape for combing between hairs or fur of the coat of an animal.

Flexible deformable membrane 56 includes holes 62 interstitially therein which are in substantial proximity and alignment with bristles elements 57 and the apertures 58 thereof. The second opening 54 receives a back cover 61 with handle 51 attached thereto. Brush base 52 further includes an orifice 65 herein located on side wall 66. Orifice 65 extends into internal cavity 53 and is adapted with a fitting 67 for connection to a second end 71 of a hose 70.

Hose 70 supplies fluid to the brush base 52 and is lightweight, and has a relatively small diameter with varying length and thickness. Hose 70 includes a first end 72 attached to a flow regulator 75 preferably by way of regulator screw top 76. Flow regulator 75 further comprises a body portion 77 appointed to be attached to a fluid or water supply and includes a threaded portion 78 therein for mating with threads or grooves of the regulator screw top 76 or an optional mixing chamber 80, as herein shown. As fluid is delivered from flow regulator 75 it passes into hose 70 and traverses orifice 65 into internal cavity 53 for delivery through bristle apertures 58. This fluid may be water or another fluid source. Flow regulator 75 controls delivery of fluid into hose 70 and internal cavity 53 of brush base 52 when brushing fur or hair, releasing fluid through apertures 62 in flexible deformable membrane 56 and apertures 58 in bristles 57 onto the animal's fur or hair. With this arrangement, the brush assembly is easy to maneuver and fluid supply can be continuous or intermittent.

In the embodiment shown in FIG. 1 the optional mixing chamber 80 is incorporated into the brush assembly 50. The optional mixing chamber 80 houses a compound appointed to be mixed with water delivered from flow regulator 75 to form a liquid solution that is appointed to be fed through hose 70 into interior cavity 53 of brush base 52 for dissemination of the liquid solution onto the fur or hair. The liquid solution preferably includes active ingredients comprising grooming and cleaning products for a coat of the horse and livestock, and may include shampoos, soaps, perfumes, fragrances and/or other active composition comprising insect repellent, flea repellants and treatments, tic repellent, mane and tail hair conditioning compositions, dye compositions, moisturizing ingredients, or antibacterial compounds.

Preferably the compound housed in the mixing chamber 80 is a semi-solid compound soluble in an aqueous environment to form the liquid solution appointed for delivery through hose 70 into interior cavity 53 of brush base 52 for delivery through bristle apertures 58. Most preferably, this semi-solid compound is a shampoo or soap. In application, the soap or shampoo in semi-solid form in the cylindrical mixing chamber 80 dissolves slowly as water is forced into mixing chamber 80 by way of flow regulator 75. As the semi-solid soap compound dissolves it suds or soaps-up to provide a soapy liquid solution that is delivered through hose 70. After approximately three to five minutes, the semi-solid becomes used-up and the soapy liquid solution begins to become diluted and subsist substantially as water.

Water continues to flow through flow regulator 75, (emptied) mixing chamber 80 and hose 70 to clean and rinse the animal. Mixing chamber 80 is preferably constructed as a cylinder having a chamber top 81 that mates with regulator screw top 76, and a chamber bottom 82 that screws onto or otherwise attaches to threaded portion 78 of flow regulator 75. Mixing chamber 80 is preferably a secondary "sale" item or after market replacement item, with replacement mixing chambers available. Washing horses and livestock can be an untidy situation with buckets, soap, sponges, and rinse water being necessary. Use of the brush assembly along with the optional mixing chamber provides the ability to deliver the soap and water in a highly efficient, tidy manner. While at the same time, the ability to get the soap deep within the fur follicles yields optimal cleaning of the animal's coat and/mane.

FIG. 2a illustrates a side view of the brush base for horses and livestock of the present invention, shown generally at 100, wherein the hose and flow regulator are not yet attached to the brush base and wherein the optional porous sponge or soluble disk is inserted into the internal cavity. Brush base 100 includes handle 51, first opening 55, second opening 54, internal cavity 53, and orifice 65 appointed with fitting 67 for connection to the second end of the hose and, consequently, the flow regulator. Flexible deformable membrane 56 with bristle elements 57 having apertures 58 is housed within first elliptical opening 55. Flexible deformable membrane 56 includes holes 62 interstitially therein aligned with bristles elements 57 and the apertures 58 thereof. Second opening 54 receives a back cover 61 with handle 51 attached thereto.

Optionally, a porous sponge or soluble disk 101 may be inserted within internal cavity 53. This optional porous sponge or soluble disk 101 may be a gel, liquid, solid, or semi-solid formulation that is water soluble and contains fragrance, perfume and/or other active composition. Water delivered by way of the flow regulator and hose enters internal cavity 53 and mixes with the water soluble formulation within the porous sponge or soluble disk 101 dissolving the formulation to form a liquid solution within internal cavity 53. Once formed, the solution is then delivered through bristle apertures 58 onto the animal's coat. Upon exhaustion of the formulation within the sponge or dissolving of the soluble disk, water may continue to flow through, rinsing the formulation off of the animal's coat, such as when the formulation is a soap or shampoo. In this optional arrangement, the flow regulator would preferably not be attached to the optional mixing chamber.

FIGS. 2b and 2c illustrate views of the brush for horses and livestock depicted in FIG. 2a: FIG. 2b illustrating a top plane view, shown generally at 180; and FIG. 2c illustrating a bottom plane view, shown generally at 190. Handle 51 extends over the brush base 52 of the brush. In operation, a user places their hand with the palm thereof facing downward toward

11

brush base 52, while the top of the hand is in contact with handles 51. Brush base 52 is constructed with internal cavity 53 having first opening 55 and second opening 54. Second opening 55 accommodates flexible deformable membrane 56 which, in turn, holds bristle elements 57 having apertures 58 to form a substantially air tight seal. Flexible deformable membrane 56 includes holes 62 in substantial proximity and alignment with bristles elements 57 and the apertures 58 thereof. Alternatively, holes 62 of membrane 56 may include a plurality of holes, particularly when bristle elements 57 have a conical shape (as shown in FIGS. 2a-2c), so that more than one hole 62 is in association with each bristle element 57 and the plurality of small holes 62 feed into or, alternatively, along the side of each bristle element 57.

FIG. 3 illustrates at 10 the brush base for horses and livestock of the subject invention with a handle 11 and brush base 12 having an internal cavity 13. In this embodiment, the hose and flow regulator are not yet connected but are also shown in the figure, shown generally at 10. Brush base 12 is constructed with an internal cavity 13 having a first opening generally marked 15 and a second opening generally marked 14. A flexible deformable membrane 16 with bristle elements 17 having apertures 18 is inserted within the first elliptical opening 15. The bristle elements 17 are shown in cross section, for clarity, to illustrate the central aperture within the bristle. The apertures in the flexible deformable membrane 16 are shown at 22. The second opening 14 receives a back cover 21 with handle 11 attached thereto. Back cover 21 is preferably attached to opening 14 via screw attachment means. Brush base 12 further includes orifice 65 which extends into internal cavity 13 and is adapted with fitting 67 for connection to second end 71 of hose 70 for delivery of the fluid from flow regulator 75 into brush base 12. Hose 70 includes first end 72 attached to flow regulator 75 preferably by way of regulator screw top 76. Flow regulator 75 further comprises a body portion 77 appointed to be attached to a fluid or water supply and includes threaded portion 78 therein for mating with threads or grooves of regulator screw top 76 (as indicated herein) or the optional mixing chamber (as shown in FIG. 1). As water is delivered from flow regulator 75 it passes into hose 70 and traverses orifice 65 into internal cavity 12 for delivery through bristle apertures 18.

FIG. 4 illustrates a cross section of the brush base of the subject invention along cross section XX of FIG. 3, shown generally at 25. In its assembled configuration, the flexible deformable membrane 16 is entirely contained within the first opening 15. The flexible deformable membrane 16 is located against the inner wall defined by the internal cavity 13 so as to form a leak-tight seal or preferably bonded to the inner wall 13. Due to the larger dimension of the flexible deformable membrane 16, it protrudes from the first opening 15 with a convex bulge. The bristle elements 17 with apertures 18 are bonded to the flexible deformable membrane 16 so that bristle apertures line up, at least in part, with corresponding holes 22 in the flexible deformable membrane. Alternatively, the apertures 18 in the flexible deformable membrane 16 are disposed with respect to the brush bristles, so that the liquid passing through apertures 18 flows along the outsides of the brush bristles. When this brush is used, the bristle elements 17 with apertures 18 attached to the flexible deformable membrane 16 contact the hair, fur, or coat of the horse, pet or livestock first, thereby deforming the flexible deformable membrane 16. Fluid is passed into internal cavity 13 through orifice 65 from the hose and flow regulator (and optional mixing chamber if applied).

FIG. 5a illustrates the flexible deformable membrane with bonded bristles 17, shown generally at 30. The flexible

12

deformable membrane has apertures 22 which are matched with the apertures 18 in the bristles 17. In this figure, the bristles are shown in cross section to illustrate clearly the central aperture. FIG. 5b shows the cross section of the bristle showing the central aperture 18 within the bristle 17 taken along plan V of FIG. 4a.

FIG. 6a illustrates the flexible deformable membrane with bonded bristles 47, shown generally at 40. The flexible deformable membrane has apertures 42 which are matched with U-shaped apertures 48 in the bristles 47. In this figure, the bristles are shown in cross section to illustrate clearly the central aperture. FIG. 5b shows the cross section of the bristle showing the central U-shaped aperture 48 within the bristle 47 taken along plan VI of FIG. 6a.

The brush assembly disclosed herein can be modified in numerous ways without departing from the scope of the invention. Optional porous sponge 59 (see FIG. 2a) can be replaced by a plastic silicon shell having aperture leading to the soluble formulation including perfume, fragrance and/or other active compositions. These ingredients are released into canals within bristles 17 and/or flow along the sides of the bristles 17 upon application of pressure.

Having thus described the invention in rather full detail, it will be understood that such detail need not be strictly adhered to, but that additional changes and modifications may suggest themselves to one skilled in the art, all falling within the scope of the invention as defined by the subjoined claims.

What is claimed is:

1. A direct application brush assembly for horses and livestock, comprising:
 - a. a molded brush base with a handle and an internal cavity with a bottom surface having a first opening, a top surface having a second opening and an orifice;
 - b. a flexible deformable membrane disposed within said first opening, said flexible deformable membrane having apertures aligned with apertures in bristles of a brush fixedly attached thereto appointed for combing through hair or fur;
 - c. said second opening being adapted to receive a cover that fits onto said second opening;
 - d. a flow regulator;
 - e. a hose having a first end fitted with said flow regulator and a second end fitted to said orifice of said brush base so that said hose delivers a fluid from said flow regulator into said internal cavity of said brush base;
 - f. each of said bristles has a circular cross section with a central aperture and a slit along the length of the bristle forming a bristle having a U-shaped cross section; wherein each of said bristles having a diameter ranging from 0.005 inch to 0.040 inch; and
 - g. a mixing chamber housing a compound appointed to be mixed with water delivered from said flow regulator to form a liquid solution that is appointed to be fed through said hose into said interior cavity of said brush base for dissemination of said liquid solution onto said fur or hair;
 whereby said flow regulator controls delivery of said fluid into said hose and said internal cavity of said brush base when brushing said fur or hair, releasing said fluid through said apertures in said flexible deformable membrane and said bristles onto said fur or hair.
2. A brush assembly as recited by claim 1, wherein each of said first and second openings is elliptical, said flexible deformable membrane is elliptical, and said cover is elliptical.

13

3. A brush assembly as recited by claim 1, wherein each of said first and second openings is circular, said flexible deformable membrane is circular, and said cover is circular.

4. A brush assembly as recited by claim 1, wherein each of said first and second openings is rectangular, said flexible deformable membrane is rectangular, and said cover is rectangular.

5. A brush assembly as recited by claim 1, wherein each of said first and second openings is square-shaped, said flexible deformable membrane is square-shaped, and said cover is square-shaped.

6. A brush assembly as recited by claim 1, wherein said flexible deformable membrane is composed of rubber having a thickness in the range of $\frac{1}{32}$ inch to $\frac{3}{32}$ inch.

7. A brush assembly as recited by claim 1, wherein said flexible deformable membrane aperture has a diameter in the range of 0.010 inch to 0.060 inch.

8. A brush assembly as recited by claim 1, wherein each of said bristles has a circular cross section, the diameter of which ranges from 0.010 to 0.060 inch.

9. A brush assembly as recited by claim 1, wherein said flexible deformable membrane is composed of a flexible polymeric material having a thickness in the range of $\frac{1}{32}$ inch to $\frac{3}{32}$ inch.

10. A brush assembly as recited by claim 1, wherein said fluid is water.

11. A brush assembly as recited by claim 1, wherein said liquid solution includes active ingredients comprising grooming and cleaning products for a coat of said horse and livestock.

12. A brush assembly as recited by claim 1, wherein said liquid solution includes active ingredients comprising animal health care products.

13. A brush assembly as recited by claim 1, wherein said liquid solution includes perfume, fragrance and/or other active composition comprising insect repellent, flea repellants and treatments, tick repellent, mane and tail hair conditioning compositions, dye compositions, moisturizing ingredients, or antibacterial compounds.

14. A brush assembly as recited by claim 1, wherein said liquid solution consists of active ingredients selected from a group consisting of insect repellants, flea and/or tick compounds, muscle treatments, therapeutic or moisturizing compounds, or antibacterial compounds.

15. A brush assembly as recited by claim 1, wherein said liquid solution consists of active ingredients selected from a group consisting of perfumes, fragrance, hair-conditioning and detangle products, sun protection lotions, mane and tail whiteners and stain removers, dye compositions, fragrances or other hair/fur/coat-care related products.

16. A brush assembly as recited by claim 1, wherein said compound housed in said mixing chamber is a semi-solid compound soluble in an aqueous environment to form said

14

liquid solution appointed for delivery through said hose and into said interior cavity of said brush base.

17. A brush assembly as recited by claim 16, wherein said semi-solid compound is a shampoo.

18. A brush assembly as recited by claim 1, wherein said mixing chamber is disposable and replacement mixing chambers are available.

19. A brush assembly as recited by claim 1, wherein a porous sponge or soluble disk is provided to be inserted within said internal cavity, wherein said porous sponge or soluble disk is water soluble and contains active ingredients and dissolves as fluid enters said internal cavity by way of said hose and said flow regulator.

20. A method for making a direct delivery brush assembly for horses and livestock coats that releases a fluid, comprising the steps of:

- a. forming a brush base having an internal cavity with a bottom surface having a first opening, a top surface having a second opening and an orifice;
- b. producing a flexible deformable membrane having apertures aligned with apertures in bristles rigidly attached thereto, each of said bristles has a circular cross section, the diameter of which ranges from 0.005 inch to 0.040 inch; each of said bristles further having a central aperture and a slit along the length of the bristles forming a bristle with a U-shaped cross section;
- c. inserting said flexible deformable membrane into said first opening in said internal cavity;
- d. inserting a cover on said second opening of said brush base;
- e. connecting a second end of a hose to said orifice of said brush base and connecting a first end of said hose to a flow regulator for delivery of said fluid into said internal cavity of said brush base;
- f. mixing a compound in a mixing chamber, said compound being appointed to be mixed with water delivered from said flow regular to form a liquid solution that is appointed to be fed through said hose into said interior cavity of said brush base for dissemination of said liquid solution onto said fur or hair;

whereby said flow regulator controls delivery of said fluid into said hose and said internal cavity of said brush base when brushing said fur or hair, releasing said fluid through said apertures in said flexible deformable membrane and said bristles onto said coat of said horse and livestock.

21. A method for making a direct delivery brush assembly as recited by claim 20, wherein said liquid solution comprises fragrance and/or other active composition comprising insect repellent, flea repellants and treatments, tick repellent, mane and tail hair conditioning compositions, dye compositions, moisturizing ingredients, or antibacterial compounds.

* * * * *