

US007896880B2

(12) **United States Patent**
Bonutti

(10) **Patent No.:** **US 7,896,880 B2**
(45) **Date of Patent:** **Mar. 1, 2011**

(54) **APPARATUS AND METHOD FOR TISSUE REMOVAL**

(75) Inventor: **Peter M. Bonutti**, Watson, IL (US)

(73) Assignee: **P Tech, LLC**, Effingham, IL (US)

(*) Notice: Subject to any disclaimer, the term of this patent is extended or adjusted under 35 U.S.C. 154(b) by 787 days.

(21) Appl. No.: **10/003,996**

(22) Filed: **Nov. 15, 2001**

(65) **Prior Publication Data**

US 2002/0055755 A1 May 9, 2002

Related U.S. Application Data

(60) Continuation of application No. 09/483,676, filed on Jan. 14, 2000, now Pat. No. 6,468,289, which is a continuation of application No. 09/323,326, filed on Jun. 1, 1999, now Pat. No. 6,174,313, which is a continuation of application No. 08/834,835, filed on Apr. 11, 1997, now Pat. No. 5,935,131, which is a division of application No. 08/695,274, filed on Aug. 9, 1996, now Pat. No. 5,694,951, which is a division of application No. 08/353,494, filed on Dec. 9, 1994, now Pat. No. 5,577,517, which is a division of application No. 08/134,914, filed on Oct. 12, 1993, now Pat. No. 5,403,317, which is a division of application No. 07/545,908, filed on Jun. 28, 1990, now Pat. No. 5,269,785.

(51) **Int. Cl.**
A61B 17/00 (2006.01)

(52) **U.S. Cl.** **606/80**

(58) **Field of Classification Search** **606/80,**
606/79, 167, 170; 600/562, 564, 565, 566,
600/567

See application file for complete search history.

(56) **References Cited**

U.S. PATENT DOCUMENTS

1,959,615 A 5/1934 Derrah

(Continued)

FOREIGN PATENT DOCUMENTS

DE 3707787 A1 3/1987

(Continued)

OTHER PUBLICATIONS

Brian A. Naughton, Hematopoiesis on Nylon Mesh Templates, vol. 18, Nos. 3 & 4, (1987), pp. 219-250.

(Continued)

Primary Examiner — Eduardo C Robert

Assistant Examiner — Mary Hoffman

(74) *Attorney, Agent, or Firm* — Fleit Gibbons Gutman Bongini & Bianco, PL; Paul D. Bianco; Martin Fleit

(57) **ABSTRACT**

Percutaneous tissue removal apparatus comprises a flexible drill shaft, a cutting tip mounted on the shaft for placement adjacent a tissue mass for cutting the tissue, means for transmitting motion to the shaft to move the cutting tip against the tissue to cut tissue fragments from the tissue, and means for removing the tissue fragments along the shaft by suction to a location outside the tissue mass while cutting. The apparatus may include means for collecting one or more selected components of the harvested tissue fragments for implantation of the fragments preferably into the body of the patient from whom they were removed. Where the tissue to be cut is bone, a cutting tip is preferably made of a polymeric material which is softer than the cortical portion of the bone, although the cutting tip may be made of a ceramic or a composite material. A second flexible shaft may be provided either within or about the flexible drill shaft. The harvested tissue fragments may be implanted in the donor patient's body.

40 Claims, 5 Drawing Sheets

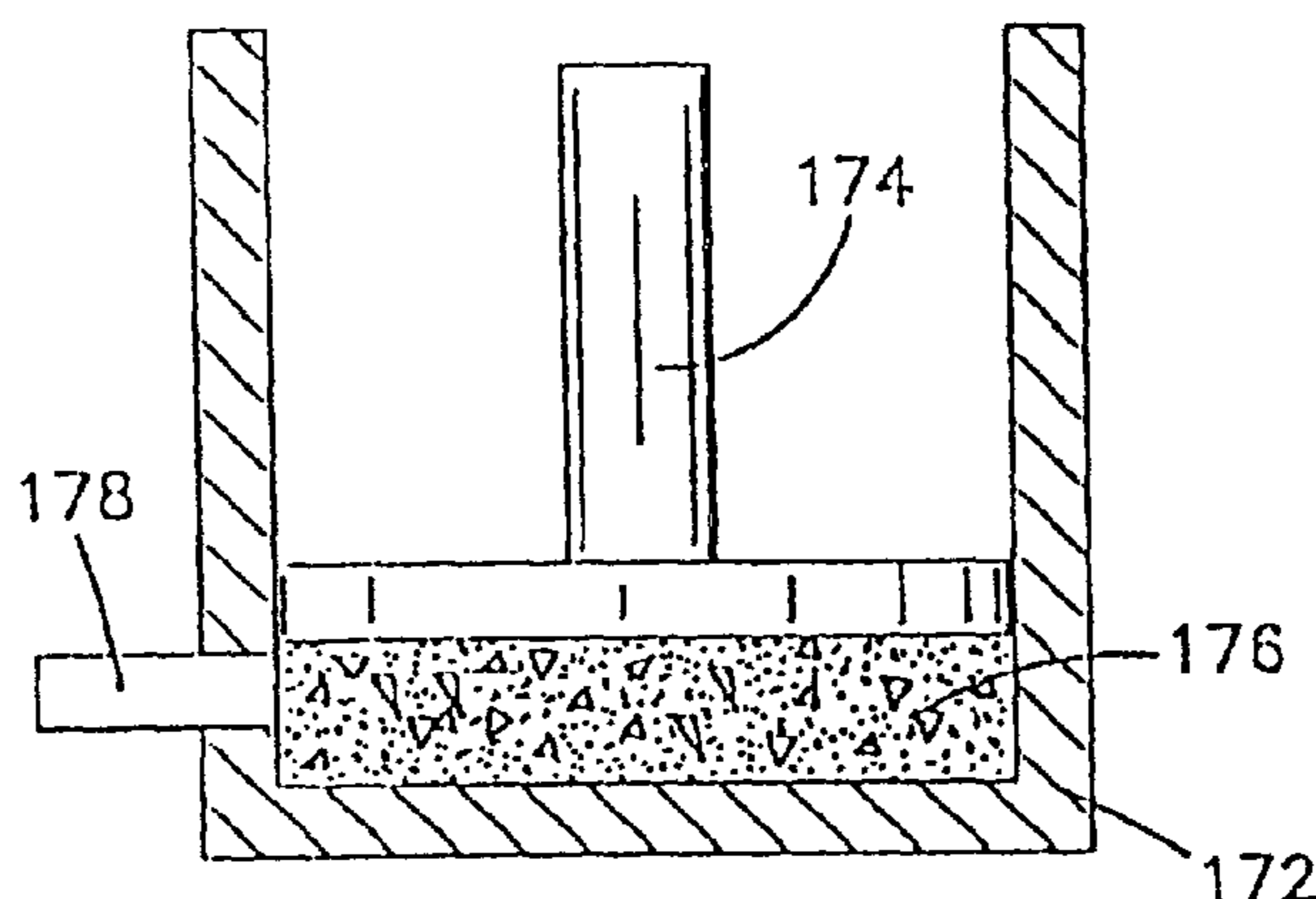

U.S. PATENT DOCUMENTS					
			4,649,918 A	3/1987	Pegg et al. 128/305
2,433,815 A	12/1947	Laforge	4,651,752 A	3/1987	Fuerst
2,526,662 A	10/1950	Hipps et al. 128/92	4,654,464 A	3/1987	Mittelmeier
2,621,145 A	12/1952	Sano 167/84	4,657,548 A	4/1987	Nichols
2,724,326 A	11/1955	Long	4,662,887 A	5/1987	Tuner
2,955,530 A	10/1960	Nilo	4,678,470 A	7/1987	Nashef et al. 623/16
3,048,522 A	8/1962	Velley	4,681,106 A	7/1987	Kensey et al. 128/305
3,108,357 A	10/1963	Liebig	4,685,473 A	8/1987	Karcher
3,224,434 A	12/1965	Molomut	4,696,667 A	9/1987	Masch
3,514,791 A	6/1970	Sparks	4,706,659 A	11/1987	Matthews
3,554,192 A	1/1971	Isberner 128/83	4,718,916 A	1/1988	Morscher
3,593,709 A	7/1971	Halloran	4,721,096 A	1/1988	Naughton
3,613,497 A	10/1971	Heldermann	4,726,373 A	2/1988	Greengrass
3,618,605 A	11/1971	Glassman	4,736,850 A	4/1988	Bowman et al.
3,655,306 A	4/1972	Ross et al.	4,743,229 A	5/1988	Chu
3,670,732 A	6/1972	Robinson	4,743,259 A	5/1988	Bolander
3,721,244 A	3/1973	Elmaleh	4,747,405 A	5/1988	Leckrone
3,769,980 A	11/1973	Karman	4,750,488 A	6/1988	Wuchinich
3,777,743 A	12/1973	Binard	4,751,922 A	6/1988	DiPietropolo 128/92
3,804,089 A	4/1974	Bridgman	4,755,184 A	7/1988	Silverberg
3,812,855 A	5/1974	Banko	4,756,708 A	7/1988	Martin
3,846,846 A	11/1974	Fischer	4,789,663 A	12/1988	Wallace et al.
3,874,264 A	4/1975	Polos	4,790,819 A	12/1988	Li
3,875,595 A	4/1975	Froning	4,794,854 A	1/1989	Swaim
3,894,530 A	7/1975	Dardik	4,795,467 A	1/1989	Piez
3,939,835 A	2/1976	Bridgman	4,798,213 A	1/1989	Doppelt 128/754
3,945,375 A	3/1976	Banko	4,801,299 A	1/1989	Brendel
4,013,071 A	3/1977	Rosenberg	4,828,563 A *	5/1989	Muller-Lierheim 623/23.63
4,083,706 A *	4/1978	Wiley 55/385.1	4,832,683 A	5/1989	Idemoto et al. 604/22
4,092,113 A	5/1978	Hardy	4,834,757 A	5/1989	Brantigan
4,122,605 A	10/1978	Hirabayashi et al.	4,840,692 A	6/1989	Kamstrup-Larsen
4,142,517 A	3/1979	Contreras Guerrero de Stavropoulos et al. 128/2	4,842,517 A	6/1989	Kawahara et al.
			4,844,064 A	7/1989	Thimsen et al. 128/305
4,186,448 A	2/1980	Brekke	4,846,791 A	7/1989	Hattler
4,191,747 A	3/1980	Scheicher	4,846,835 A	7/1989	Grande
4,210,580 A *	7/1980	Amrani 530/383	4,857,045 A	8/1989	Rydell 604/22
4,243,048 A	1/1981	Griffin	4,863,472 A	9/1989	Tormala
4,245,653 A	1/1981	Weaver	4,867,157 A	9/1989	McGurk Burleson
4,259,072 A	3/1981	Hirabayashi et al.	4,883,666 A	11/1989	Sabel et al.
4,262,028 A	4/1981	Meyer et al.	4,888,022 A	12/1989	Huebsch
4,265,231 A	5/1981	Scheller, Jr. et al. 128/92	4,890,612 A	1/1990	Kensey
4,274,414 A	6/1981	Johnson	4,892,538 A	1/1990	Aebischer et al.
4,298,002 A	11/1981	Ronel et al.	4,892,552 A	1/1990	Ainsworth
4,298,998 A	11/1981	Naficy	4,902,296 A	2/1990	Bolander
4,304,178 A	12/1981	Haberle	4,904,259 A	2/1990	Itay
4,352,883 A	10/1982	Lim	4,911,641 A	3/1990	Detsch
4,391,909 A	7/1983	Lim	4,932,973 A	6/1990	Gendler
4,400,833 A	8/1983	Kurland	4,936,848 A *	6/1990	Bagby 623/17.16
4,430,760 A	2/1984	Smestad	4,950,296 A	8/1990	McIntyre 623/16
4,442,655 A	4/1984	Stroetmann	4,961,740 A	10/1990	Ray
4,445,509 A	5/1984	Auth	4,963,489 A	10/1990	Naughton
4,453,421 A	6/1984	Umamo	4,969,888 A	11/1990	Scholten et al.
4,466,429 A	8/1984	Loscher et al. 128/92	4,969,904 A	11/1990	Koch et al.
4,466,888 A	8/1984	Verkaart	4,976,682 A	12/1990	Lane et al.
4,472,840 A	9/1984	Jefferies 128/92	4,976,684 A	12/1990	Broadnax
4,484,570 A	11/1984	Sutter et al.	4,978,355 A	12/1990	Frey et al.
4,485,096 A	11/1984	Bell	4,983,721 A	1/1991	Davison
4,485,097 A	11/1984	Bell	4,984,585 A	1/1991	Austad
4,501,264 A	2/1985	Rockey	4,994,067 A	2/1991	Summers 606/159
4,501,269 A	2/1985	Bagby	5,009,664 A	4/1991	Sievers
4,502,159 A	3/1985	Woodroof	5,015,247 A	5/1991	Michelson
4,516,276 A	5/1985	Mittelmeier	5,027,827 A *	7/1991	Cody et al. 600/566
4,541,423 A	9/1985	Barber 128/92	5,030,201 A	7/1991	Palestrant
4,551,135 A	11/1985	Gorman	5,047,040 A	9/1991	Simpson
4,553,272 A	11/1985	Mears	5,055,198 A	10/1991	Shettigar
4,554,686 A	11/1985	Baker 623/16	5,057,120 A	10/1991	Fargot
4,562,598 A	1/1986	Kranz	5,059,193 A	10/1991	Kuslich
4,570,271 A	2/1986	Sump	5,061,286 A	10/1991	Lyle
4,573,448 A *	3/1986	Kambin 606/170	5,062,843 A	11/1991	Mahony
4,589,414 A	5/1986	Yoshida et al. 128/305	5,062,845 A	11/1991	Kuslich
4,598,698 A	7/1986	Siegmund	5,073,114 A	12/1991	Detsch
4,603,694 A	8/1986	Wheeler 128/312	5,073,373 A	12/1991	O'Leary et al. 424/422
4,611,581 A	9/1986	Steffee	5,082,670 A	1/1992	Gage
4,623,553 A	11/1986	Ries et al.	5,084,050 A	1/1992	Draenert
4,642,117 A	2/1987	Nguyen et al.	5,087,260 A	2/1992	Fixel
4,642,120 A	2/1987	Nevo	5,098,435 A	3/1992	Stednitz
4,646,736 A	3/1987	Auth	5,100,424 A	3/1992	Jang
4,646,738 A	3/1987	Trott	5,101,720 A	4/1992	Bianchi
			5,108,438 A	4/1992	Stone

5,112,354 A 5/1992 Sires
 5,135,488 A 8/1992 Foote et al.
 5,152,744 A 10/1992 Krause et al.
 5,152,776 A 10/1992 Pinchok
 5,158,881 A 10/1992 Aebischer et al.
 5,162,430 A 11/1992 Rhee et al.
 5,162,506 A 11/1992 Hadden
 5,166,048 A 11/1992 Soil et al.
 5,167,239 A 12/1992 Cohen
 5,171,244 A 12/1992 Caspari et al. 606/88
 5,171,273 A 12/1992 Silver et al.
 5,181,930 A 1/1993 Dumbleton et al.
 5,185,001 A 2/1993 Galanakis
 5,188,834 A 2/1993 Grimm et al.
 5,190,541 A 3/1993 Abele
 5,192,327 A 3/1993 Brantigan
 5,204,106 A 4/1993 Schepers et al. 424/423
 5,212,082 A 5/1993 Goldstein
 5,226,877 A * 7/1993 Epstein 606/94
 5,236,456 A 8/1993 O'Leary
 5,240,862 A 8/1993 Koenhan et al.
 5,246,457 A 9/1993 Piez et al.
 5,269,785 A 12/1993 Bonutti 606/80
 5,278,201 A 1/1994 Dunn et al.
 5,284,655 A 2/1994 Bogdanský et al. 424/422
 5,285,655 A 2/1994 Sung
 5,285,795 A 2/1994 Ryan
 5,298,254 A 3/1994 Prewet et al. 424/422
 5,329,846 A 7/1994 Bonutti
 5,355,898 A 10/1994 Ripamonti
 5,372,138 A 12/1994 Crowley
 5,390,683 A 2/1995 Pisharodi 128/898
 5,401,759 A 3/1995 Dunnett
 5,403,317 A 4/1995 Bonutti 606/80
 5,443,443 A 8/1995 Shiber
 5,480,437 A 1/1996 Draenert
 5,487,897 A 1/1996 Polson
 5,501,706 A 3/1996 Arenberg
 5,507,807 A 4/1996 Shippert
 5,514,153 A 5/1996 Bonutti 606/190
 5,545,222 A 8/1996 Bonutti
 5,577,517 A 11/1996 Bonutti 128/898
 5,593,425 A 1/1997 Bonutti
 5,660,849 A 8/1997 Polson
 5,662,710 A 9/1997 Bonutti
 5,694,951 A * 12/1997 Bonutti 606/80
 5,713,853 A 2/1998 Clark
 5,779,728 A 7/1998 Lunsford et al. 606/190
 5,833,692 A 11/1998 Cesarini
 5,868,749 A 2/1999 Reed
 5,888,219 A 3/1999 Bonutti
 5,904,718 A 5/1999 Jefferies
 5,935,131 A 8/1999 Bonutti
 5,954,739 A 9/1999 Bonutti 606/190
 5,968,048 A 10/1999 Harder
 6,025,538 A 2/2000 Yaccarino
 6,132,472 A 10/2000 Bonutti
 6,156,070 A 12/2000 Incavo
 6,174,313 B1 1/2001 Bonutti

6,261,295 B1 * 7/2001 Nicholson et al. 606/87
 6,311,690 B1 11/2001 Jefferies
 6,312,438 B1 11/2001 Adams
 6,325,806 B1 * 12/2001 Fox 606/80
 6,358,252 B1 * 3/2002 Shapira 606/80
 6,361,565 B1 3/2002 Bonutti
 6,409,764 B1 * 6/2002 White et al. 623/16.11
 6,503,277 B2 1/2003 Bonutti
 RE38,018 E 3/2003 Anctil
 7,727,283 B2 6/2010 Bonutti
 2002/0151975 A1 10/2002 Farr et al.

FOREIGN PATENT DOCUMENTS

EP 0192576 A1 8/1986
 FR 2344267 11/1977
 JP 1029266 1/1989
 JP 6429266 1/1989
 SU 1275136 12/1986
 WO WO 88/01517 3/1988
 WO 9116419 10/1991

OTHER PUBLICATIONS

Marcel E. Nimmi, Ectopic Bone Formation Is Enhanced in Senescent Animals Implanted with Embryonic Cells, *Clinical Orthopaedic and Related Research* 234, (1988), pp. 255-266.
 John A. Bierly, Osseous Filtration: An Improved Technique for Bone Implantation, *J. Periodontol.*, Jun. 1974, pp. 414-420.
 Robert E. Marx et al., A Technique for the Compression and Carriage of Autogenous Bone During Bone Grafting Procedures, *J. Oral Maxillofac Surg.*, 45:988-989, 1987.
 John Connolly, Development of an Osteogenic Bone-Marrow Preparation, *The Journal of Bone and Joint Surgery*, vol. 71-A, Jun. 1989, pp. 684-691.
 John A. Robertson et al., *Washington University Law Quarterly*, vol. 66, No. 3, 1988.
 Golbus, Mitchell S, et al., "Fetal Tissue Sampling"—The San Francisco Experience with 190 Pregnancies" *West J Med Apr.* 1989; 150: 423-430.
 The Technic of Fibrin Glue in Cancellous bone transplants, *Arch Orthop Unfairchir.* Nov. 21, 1977; (1);63-75.
 Philip W. Kantoff, "In Utero Gene Transfer and Expression: A Sheep Transplantation Model", *Blood Journal*, vol. 73, No. 4 (Mar. 1989): pp. 1066-1073.
 K.M. Rudall, "Development of Wool Follicles and Fibres on Autoplastic Grafts of Stored Foetal Lamb Skin", *Biology of the Skin and hair growth*, p. 75-88, 1965.
 Co-pending U.S. Appl. No. 10/233,866, Final Rejection mailed Dec. 15, 2009.
 Co-pending U.S. Appl. No. 09/872,526, Final Rejection mailed Apr. 2, 2010.
 Co-pending U.S. Appl. No. 10/793,266, Non-Final Office Action mailed Jan. 5, 2010.

* cited by examiner

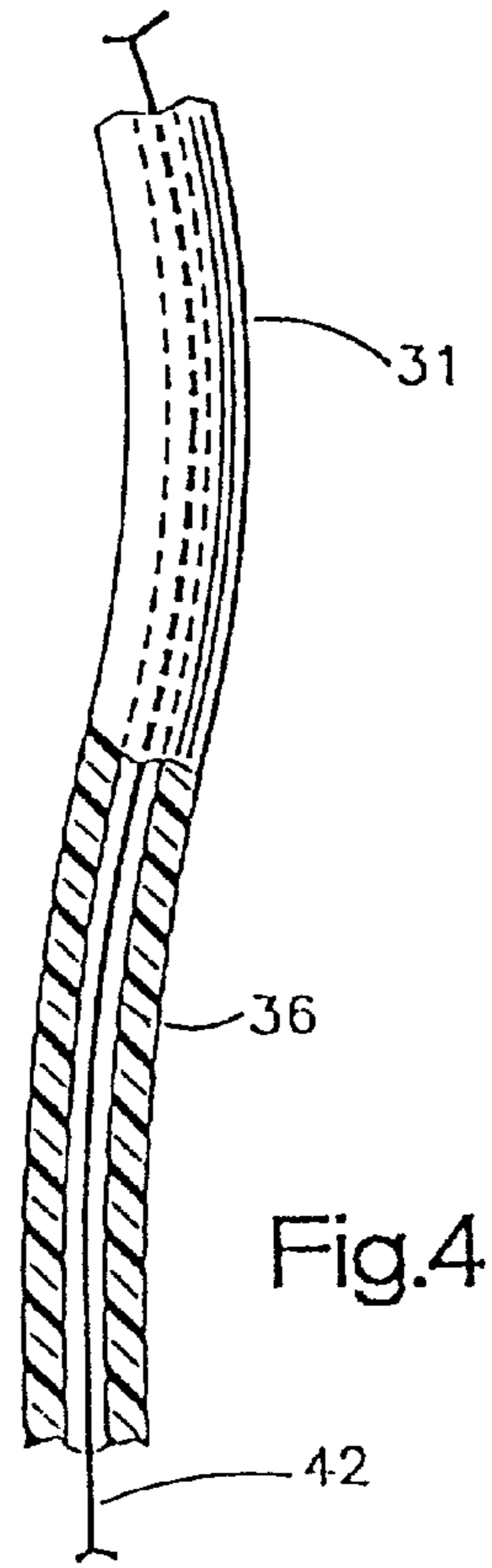
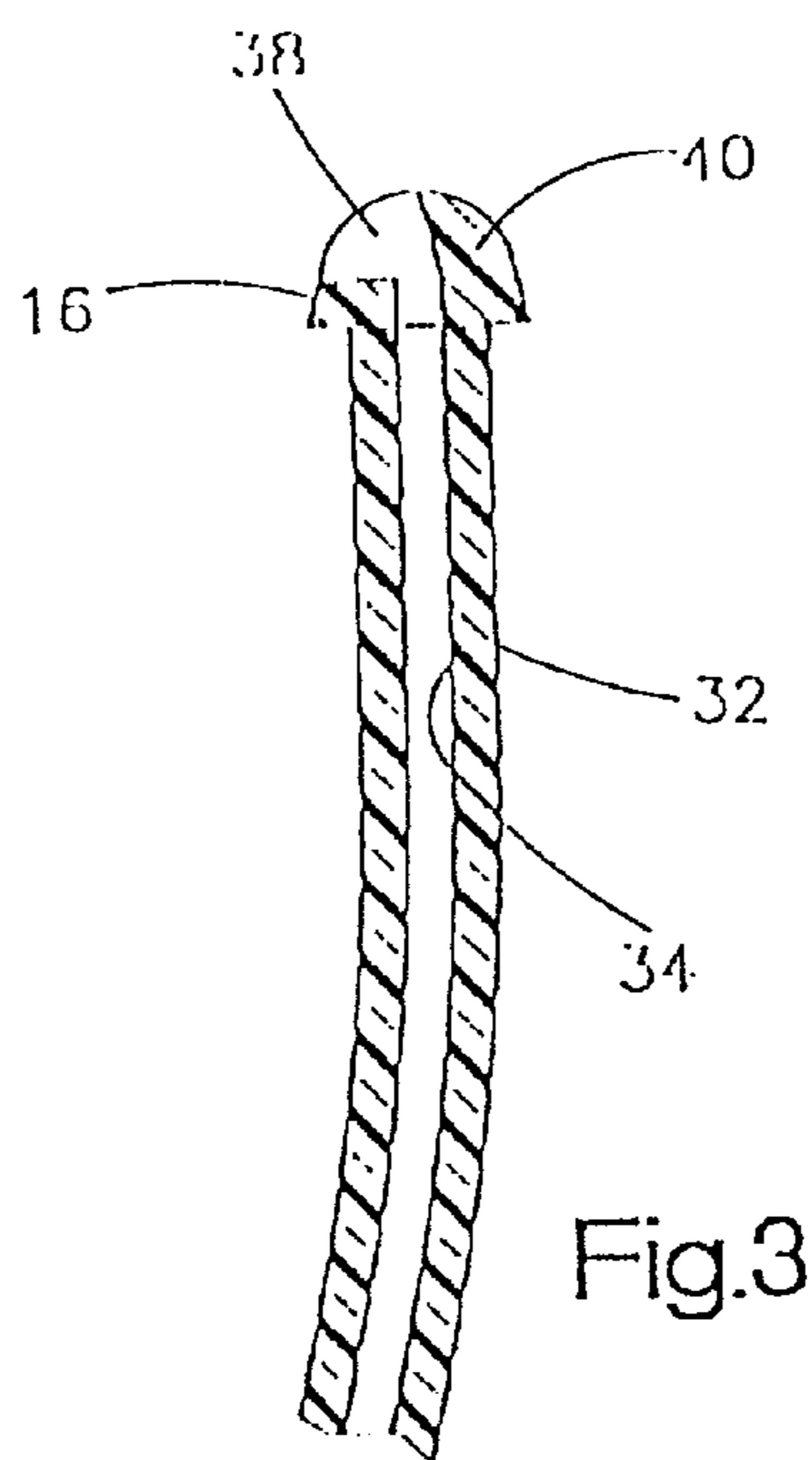
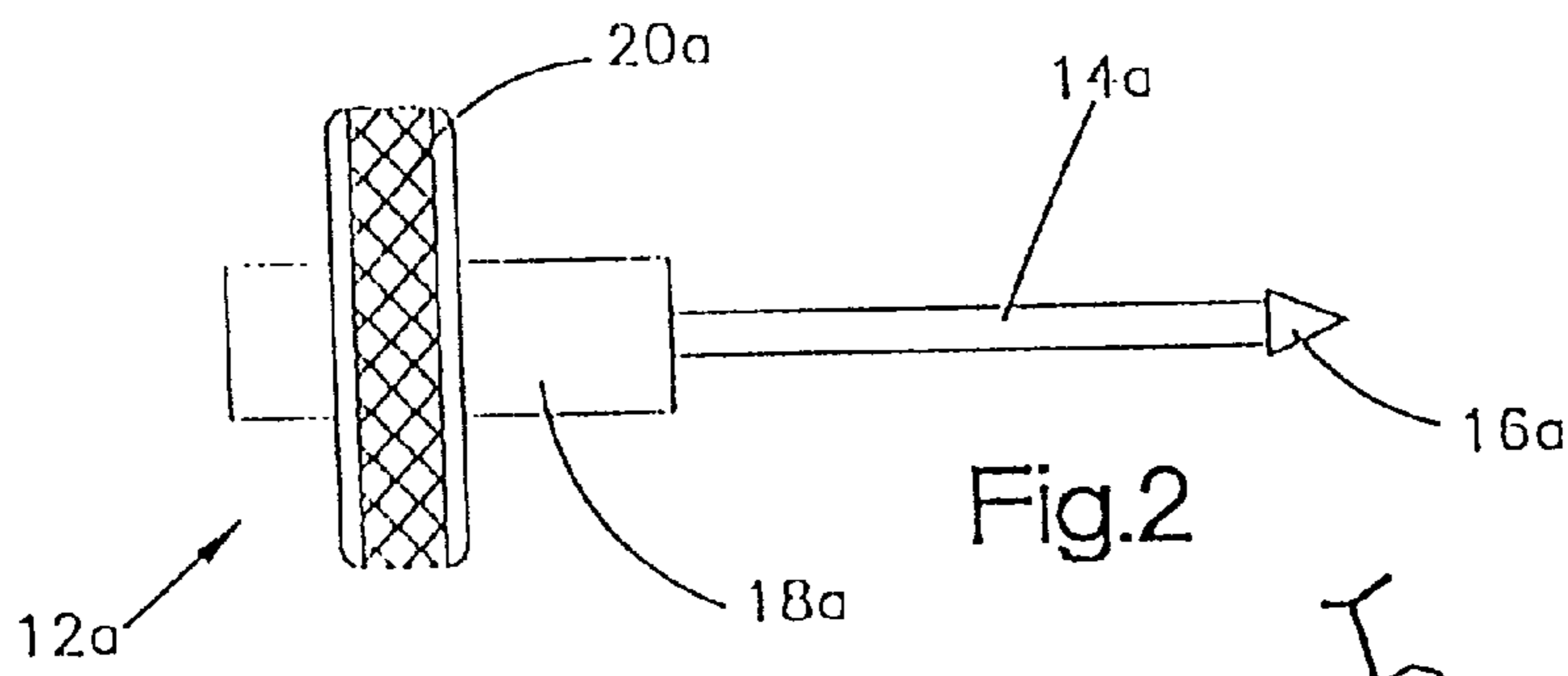
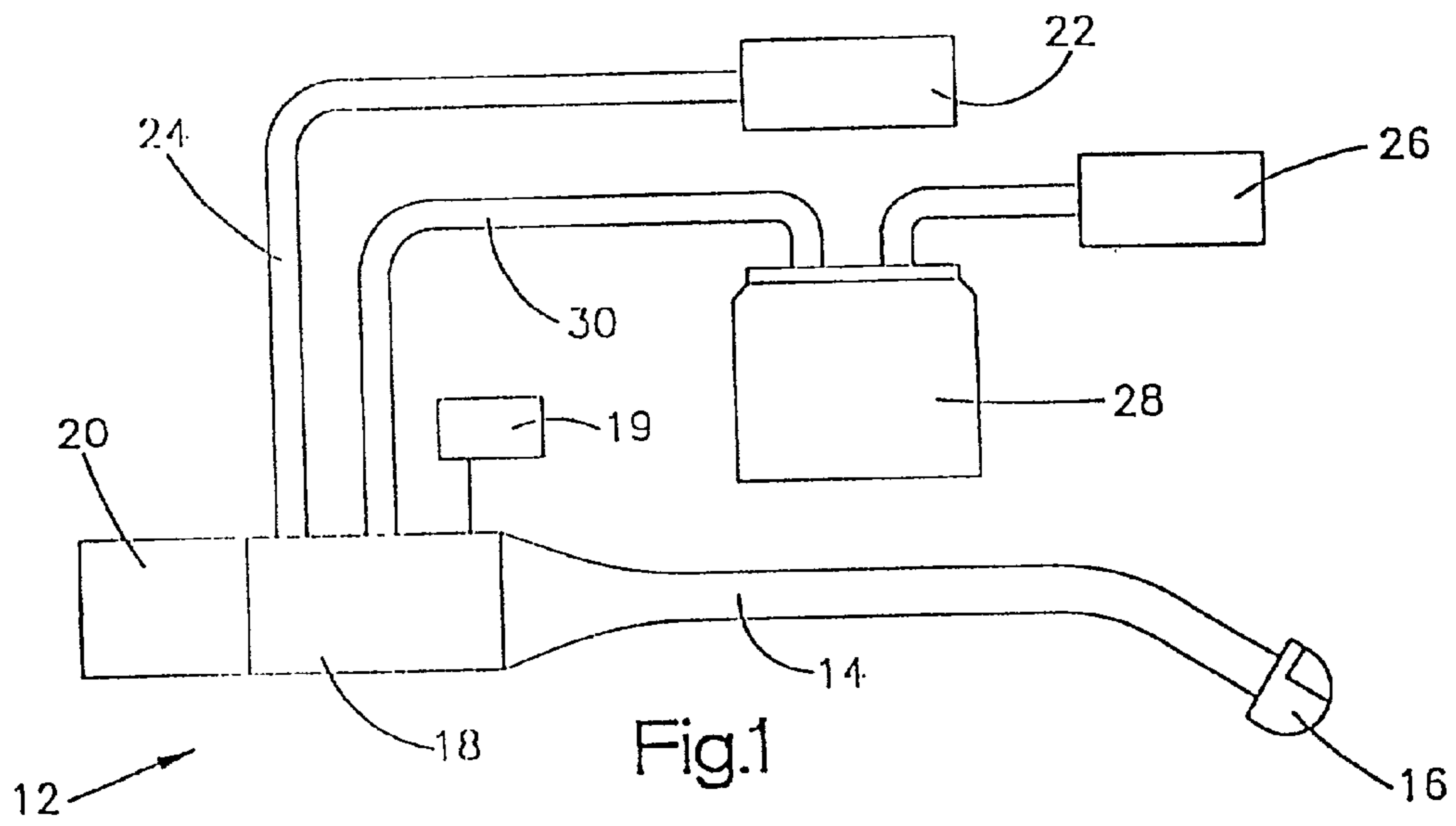

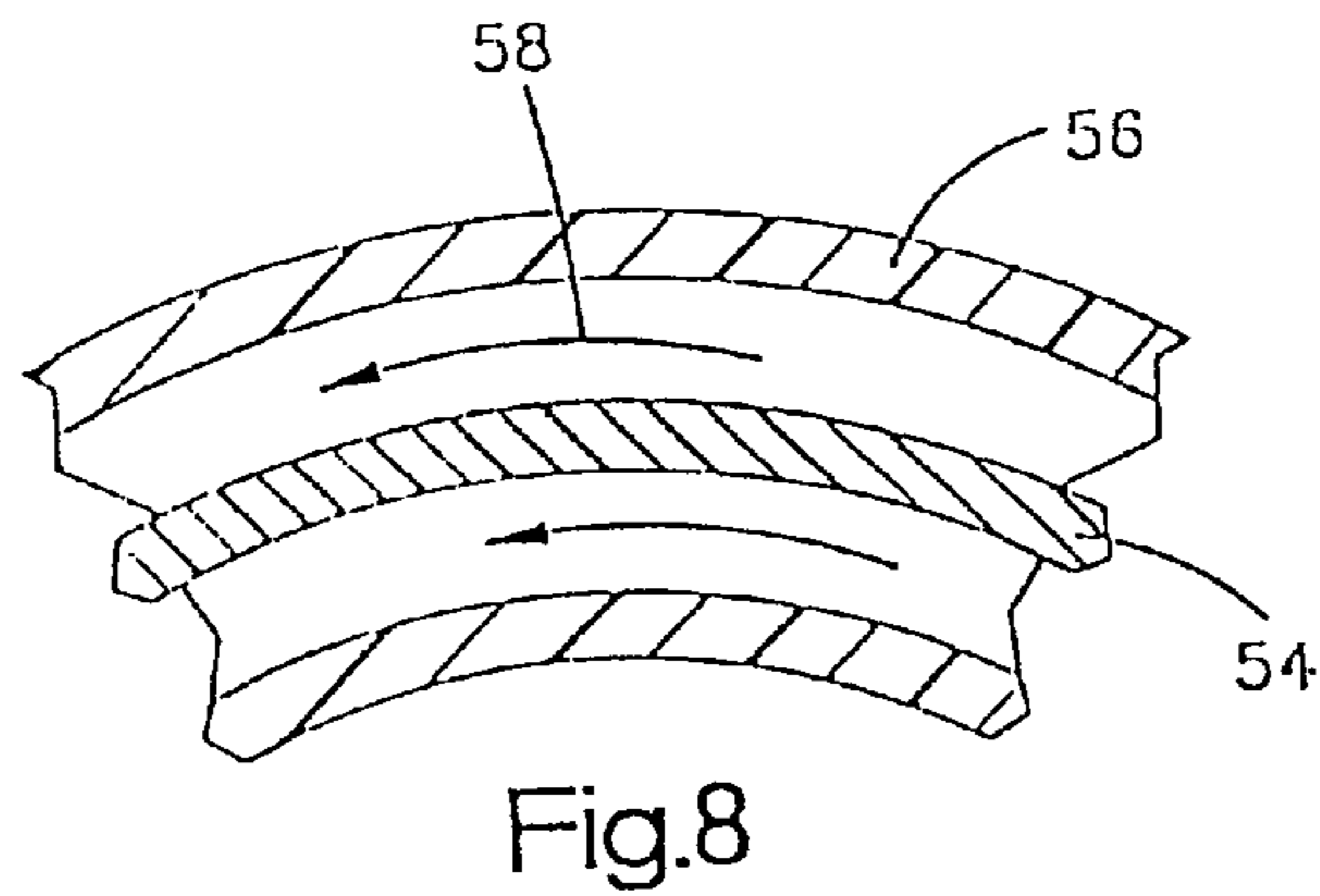
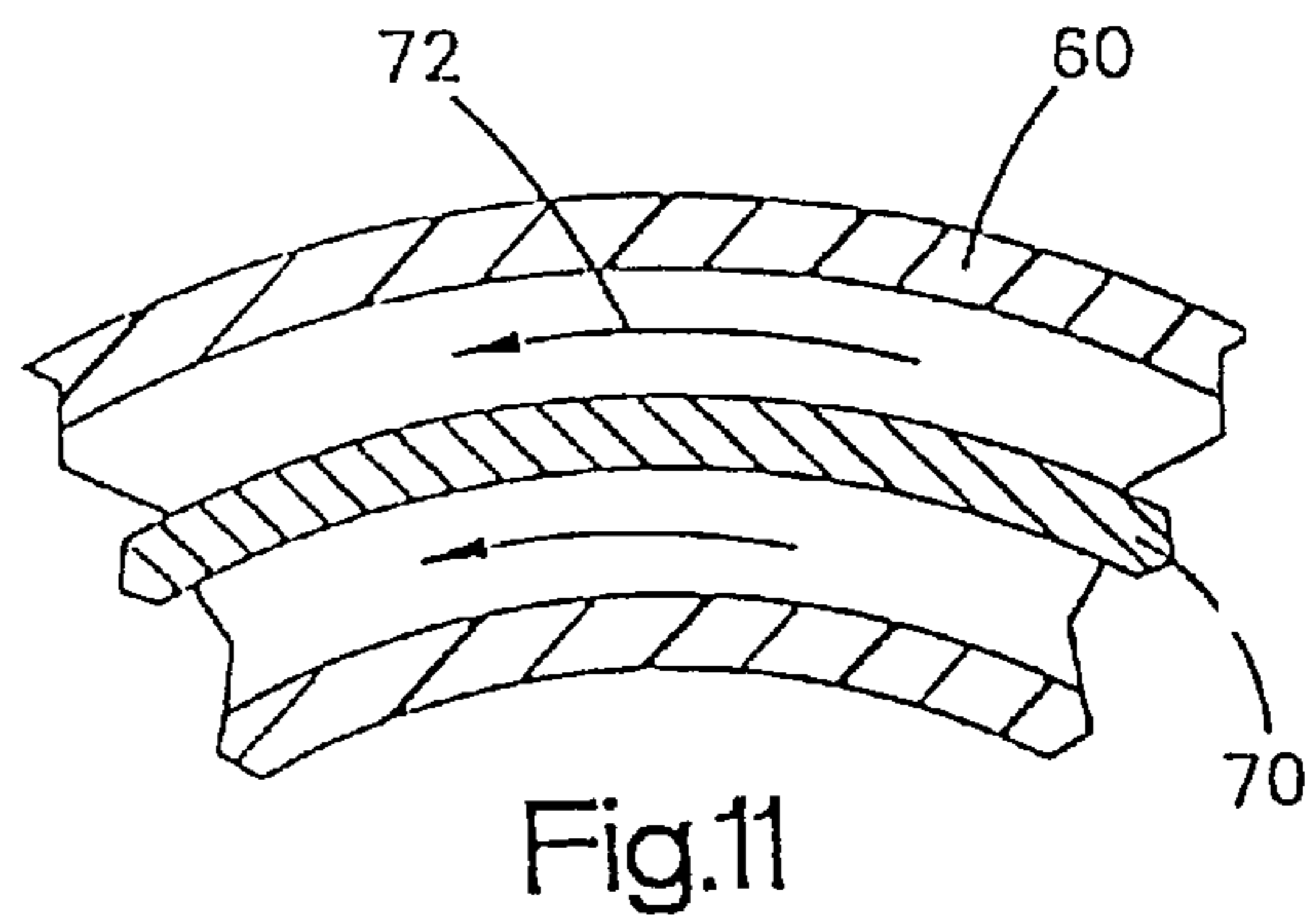
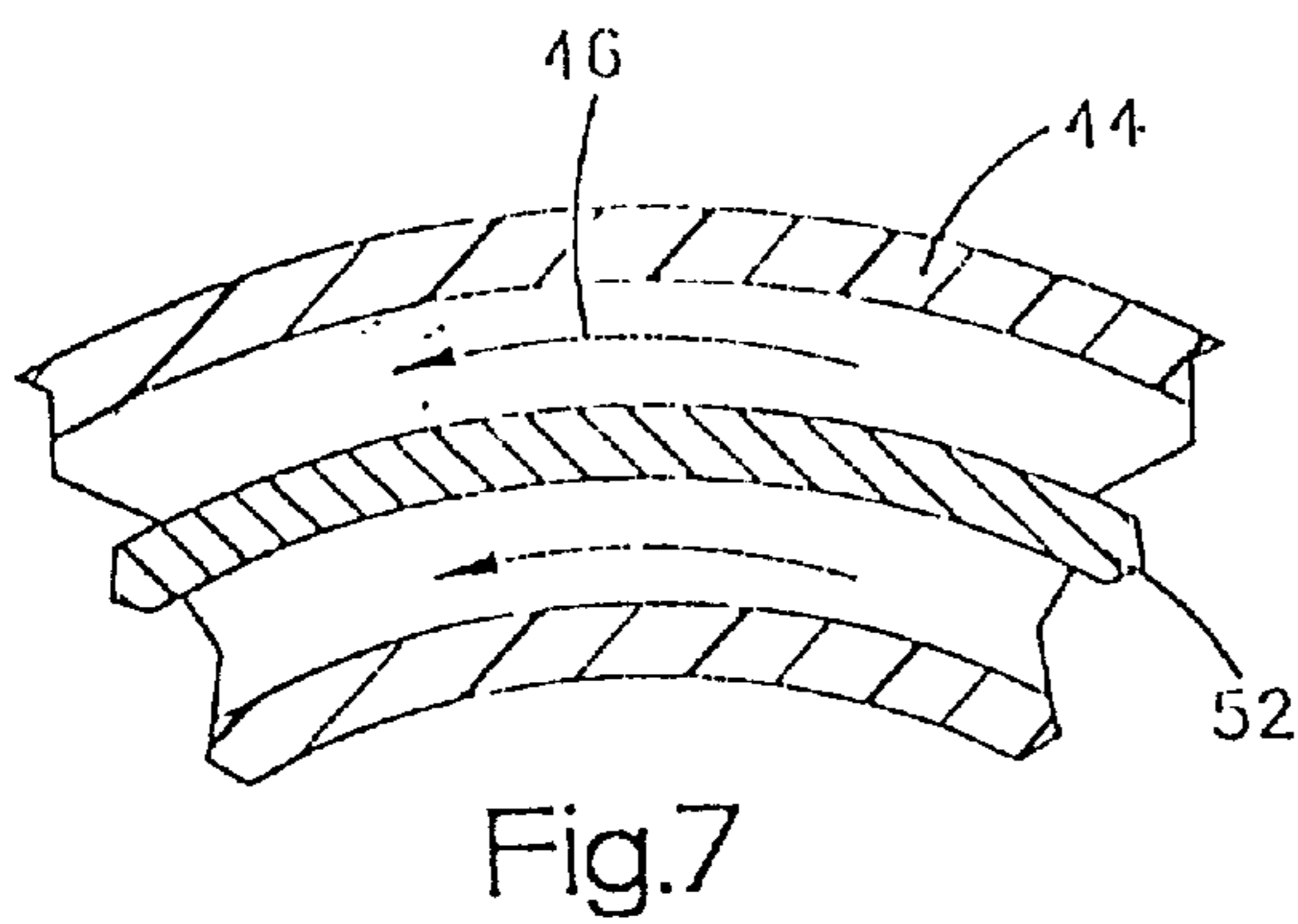
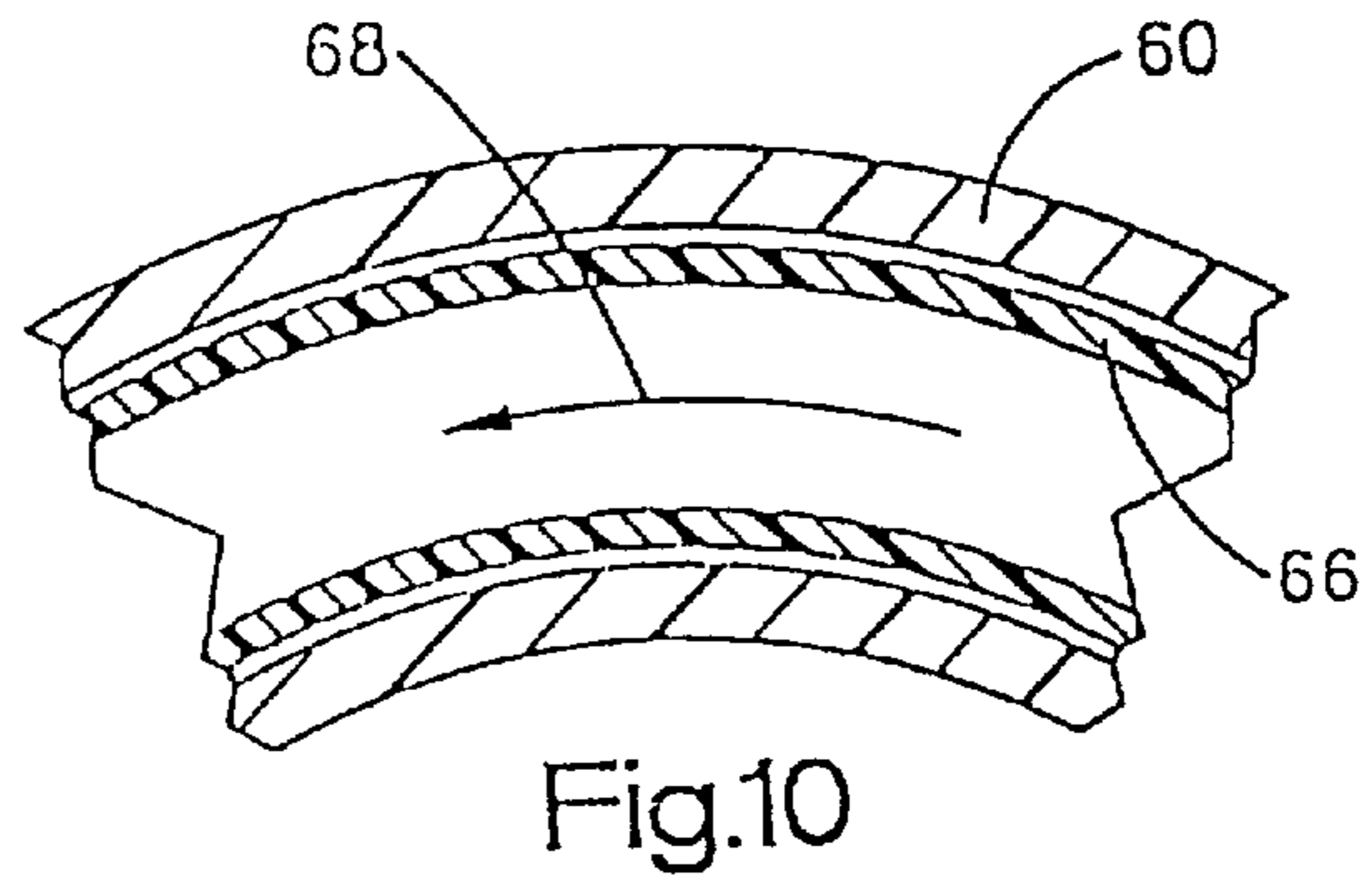
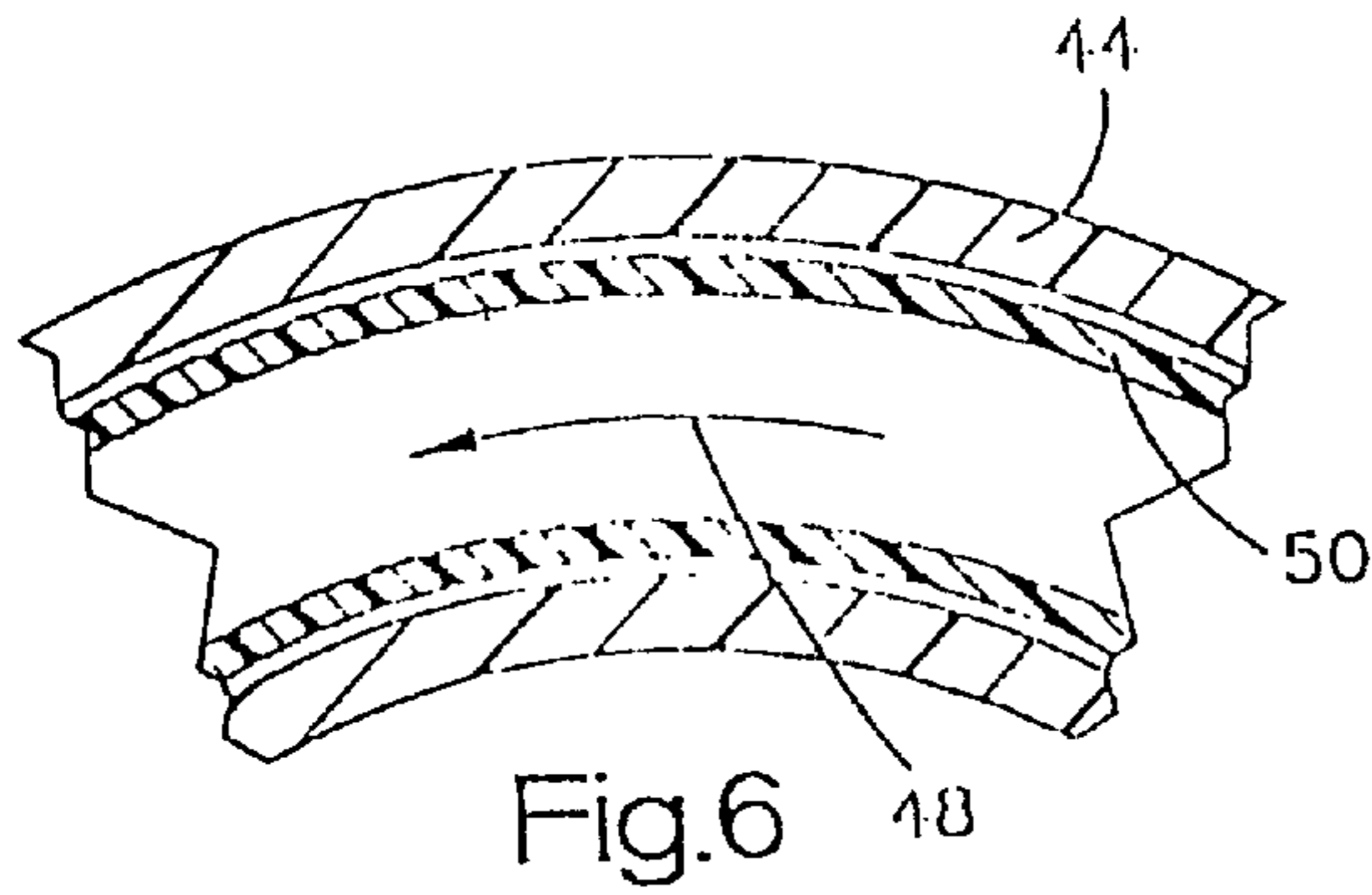
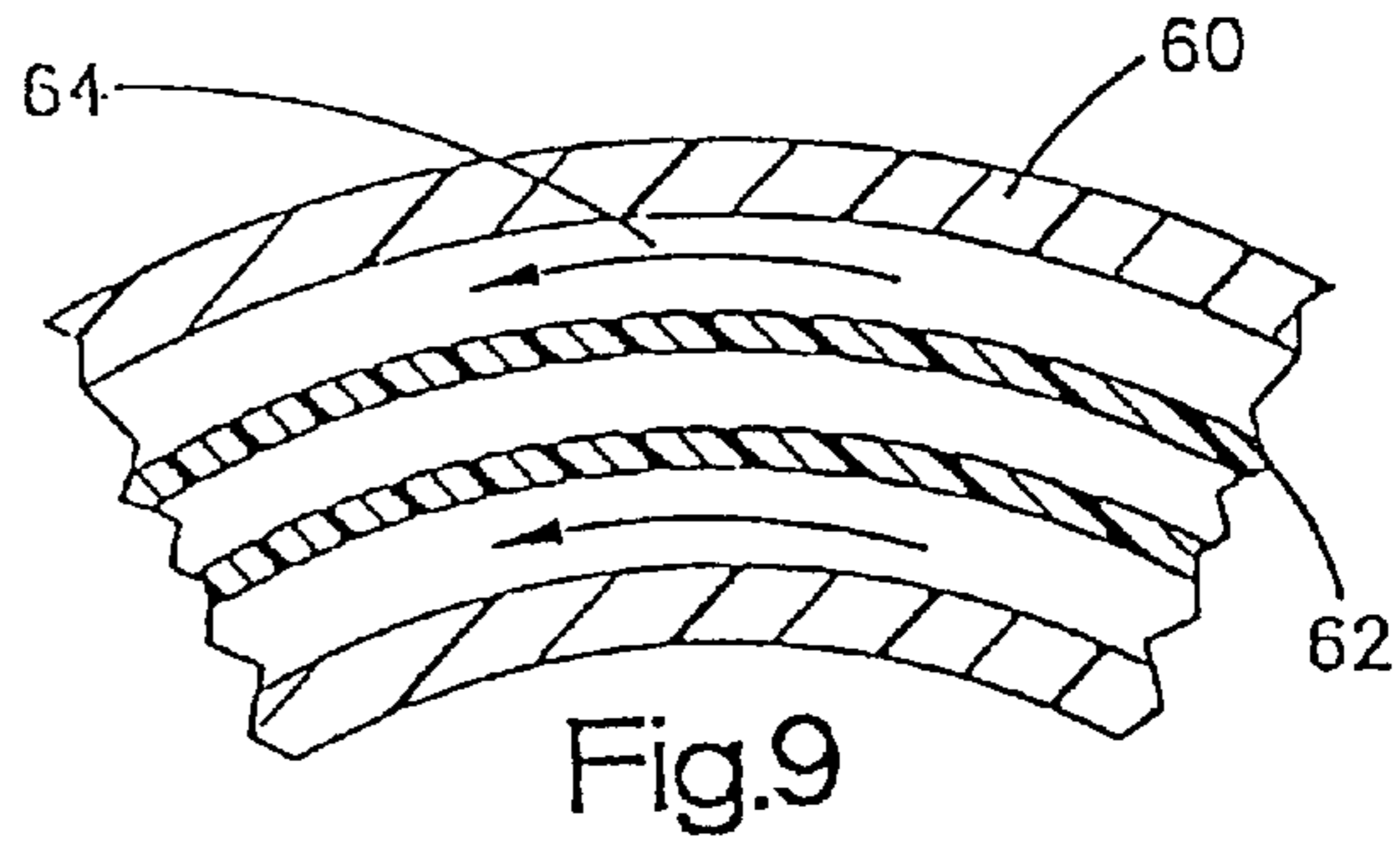
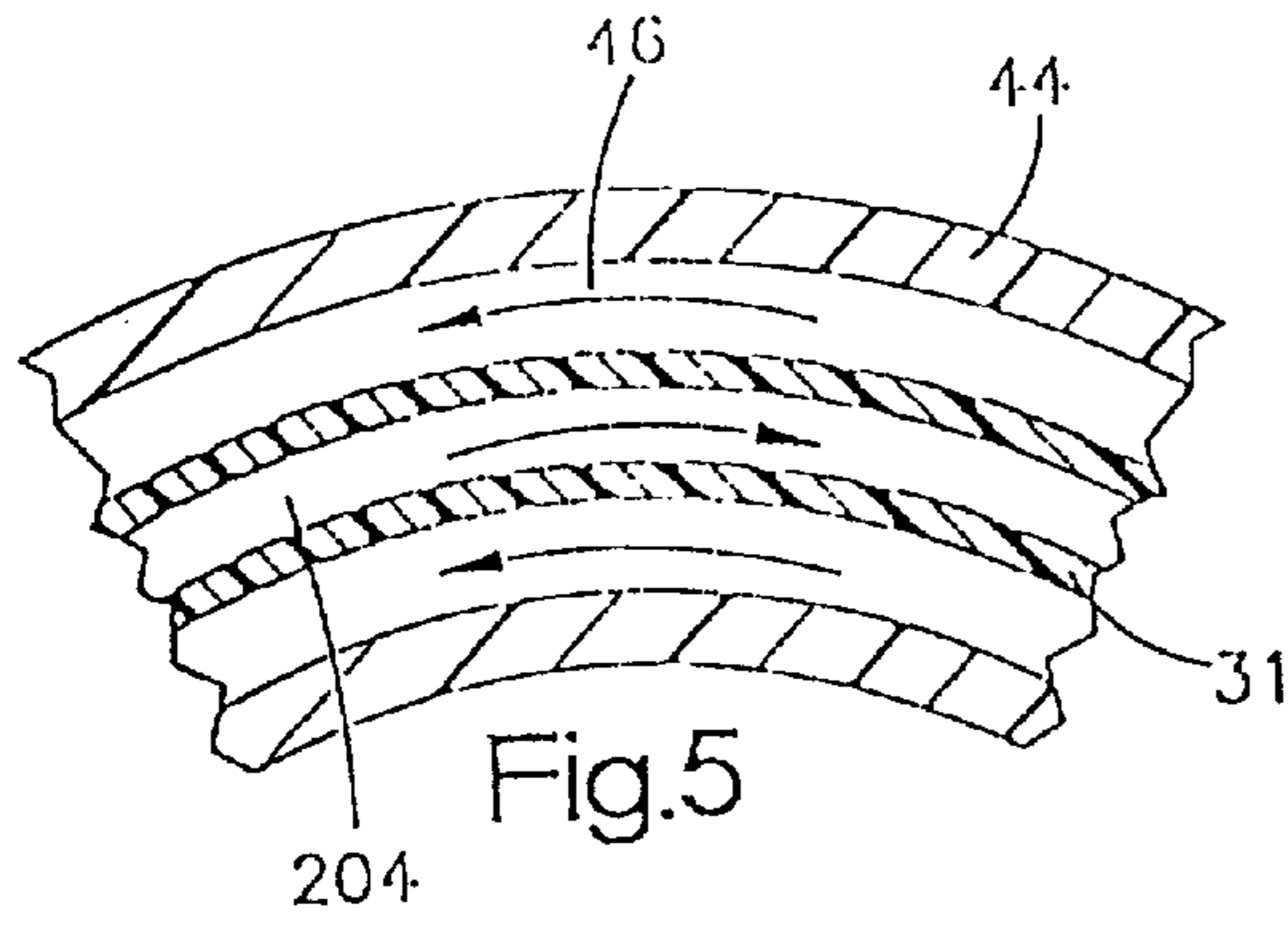

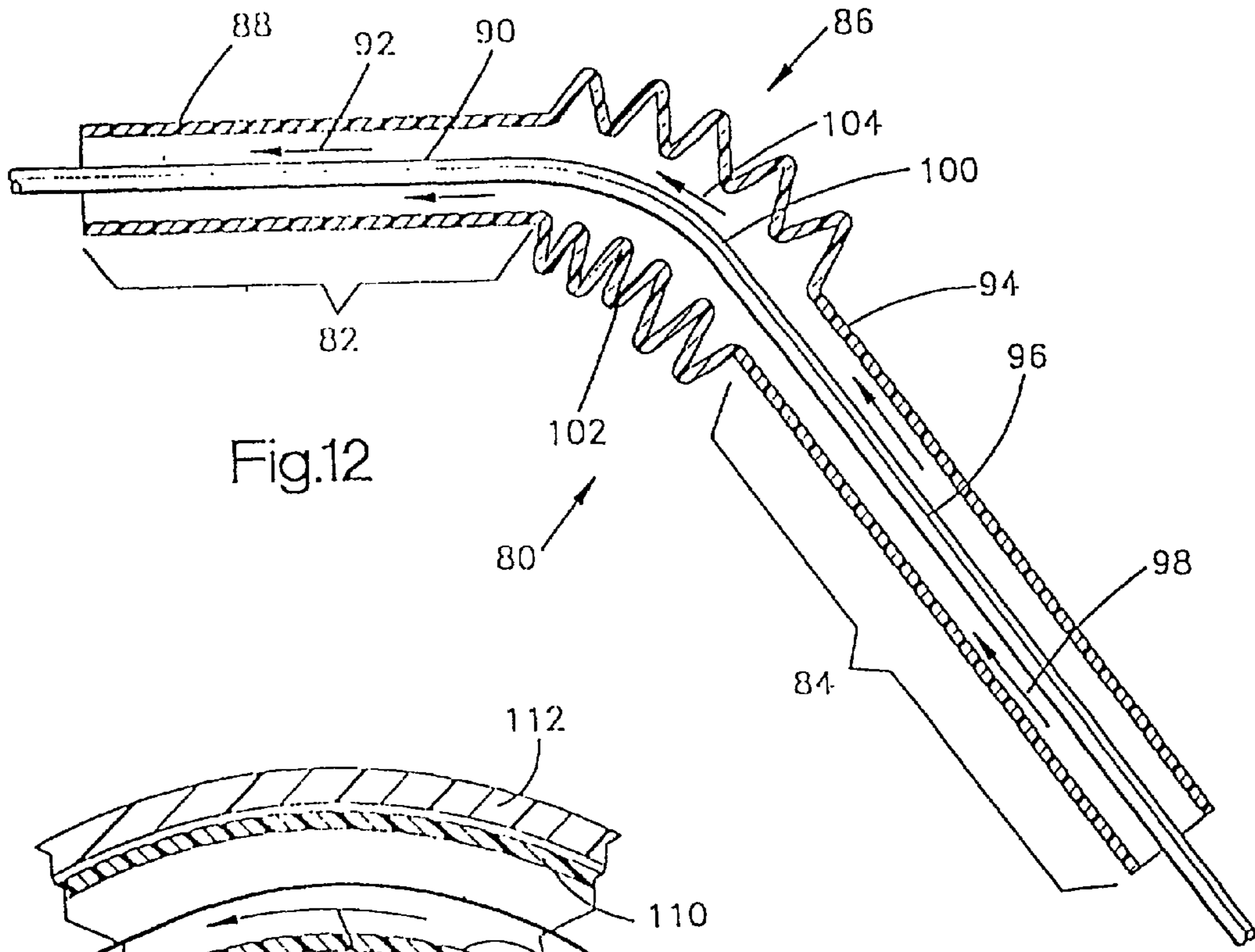

Fig.12

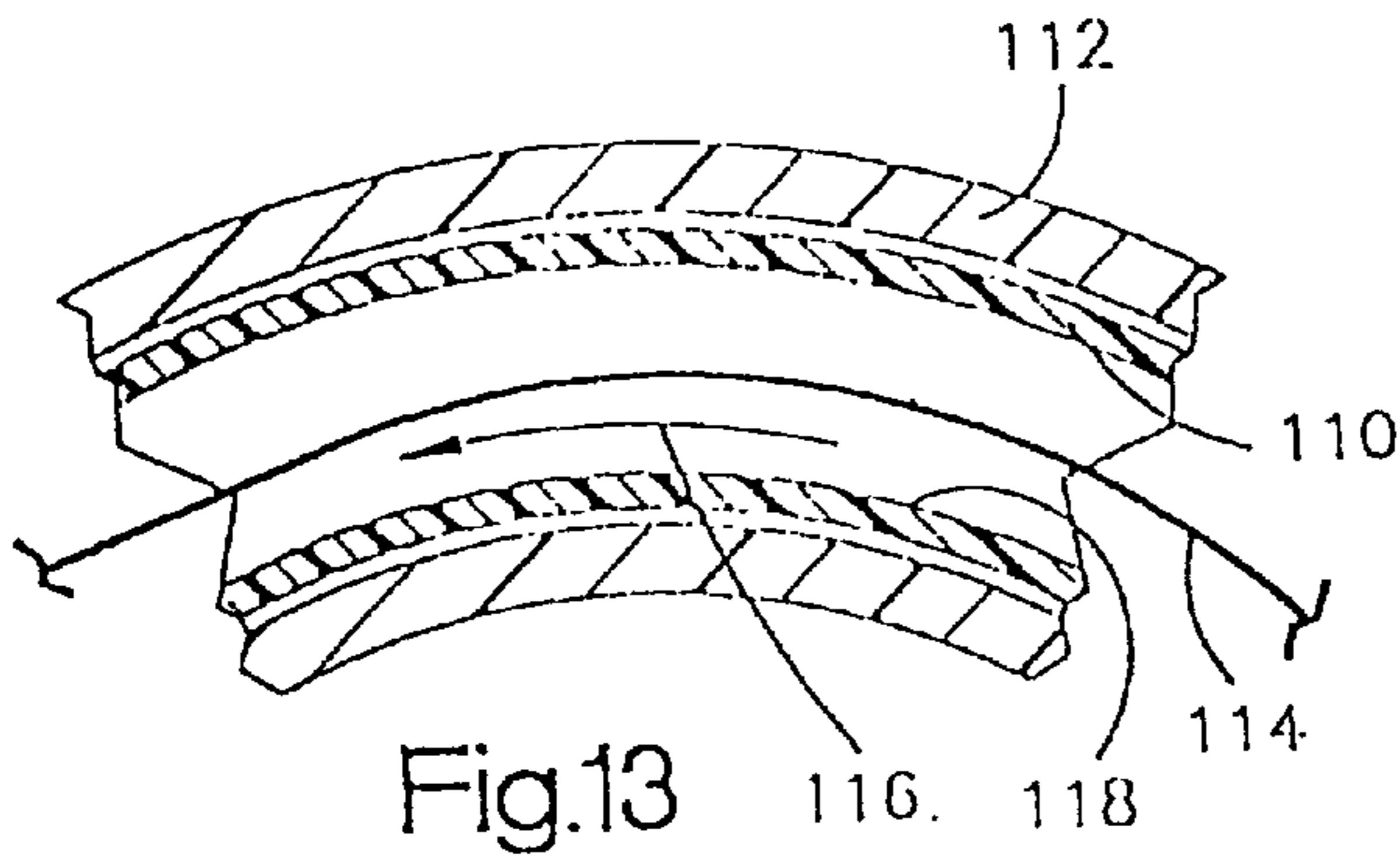

Fig.13

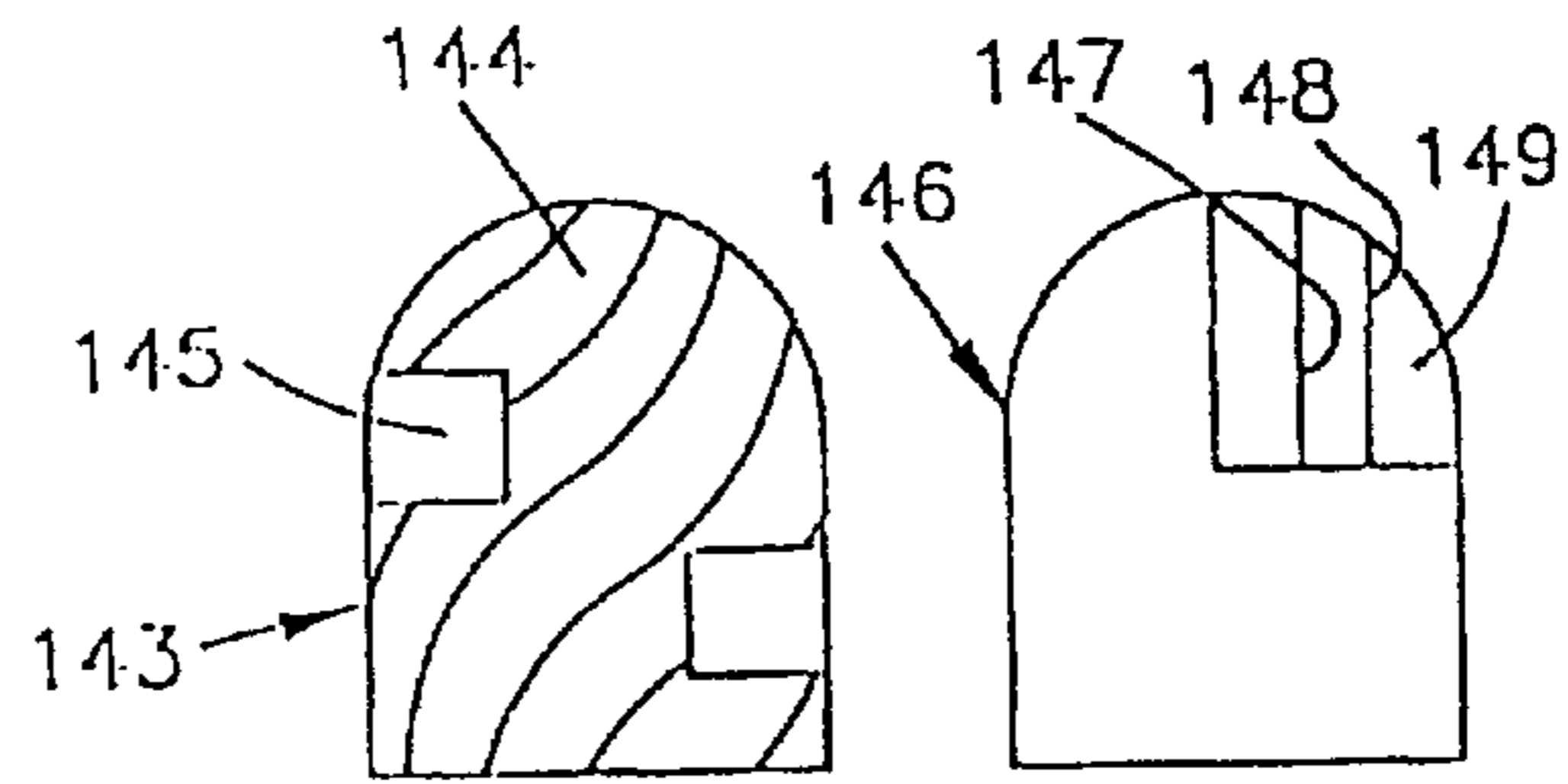

Fig.14F

Fig.14G

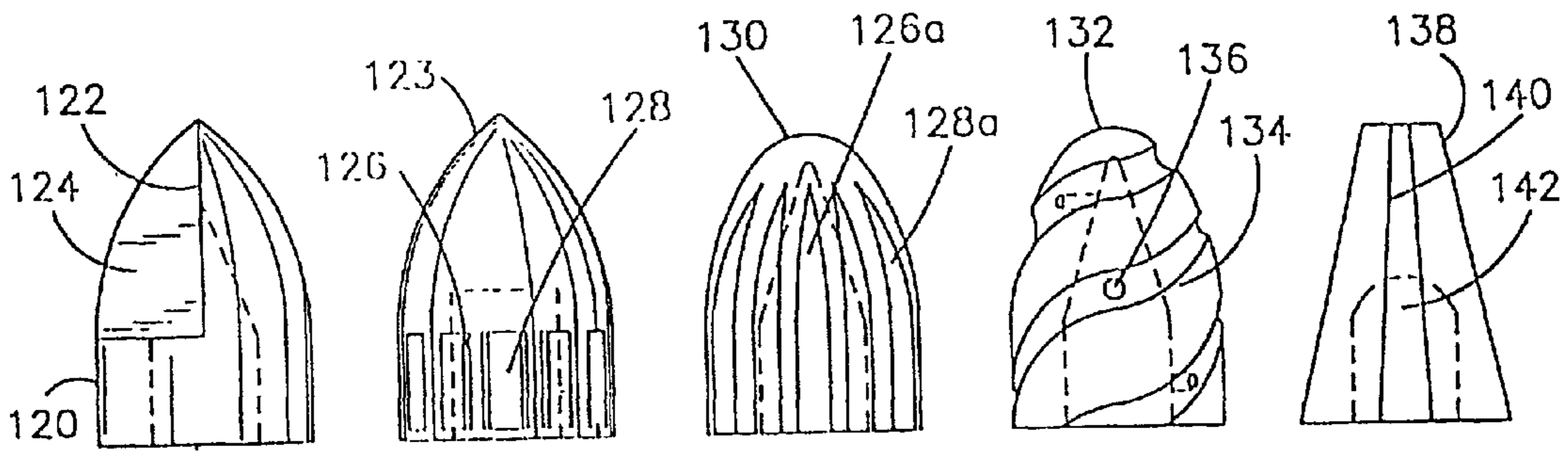

Fig.14A

Fig.14B

Fig.14C

Fig.14D

Fig.14E

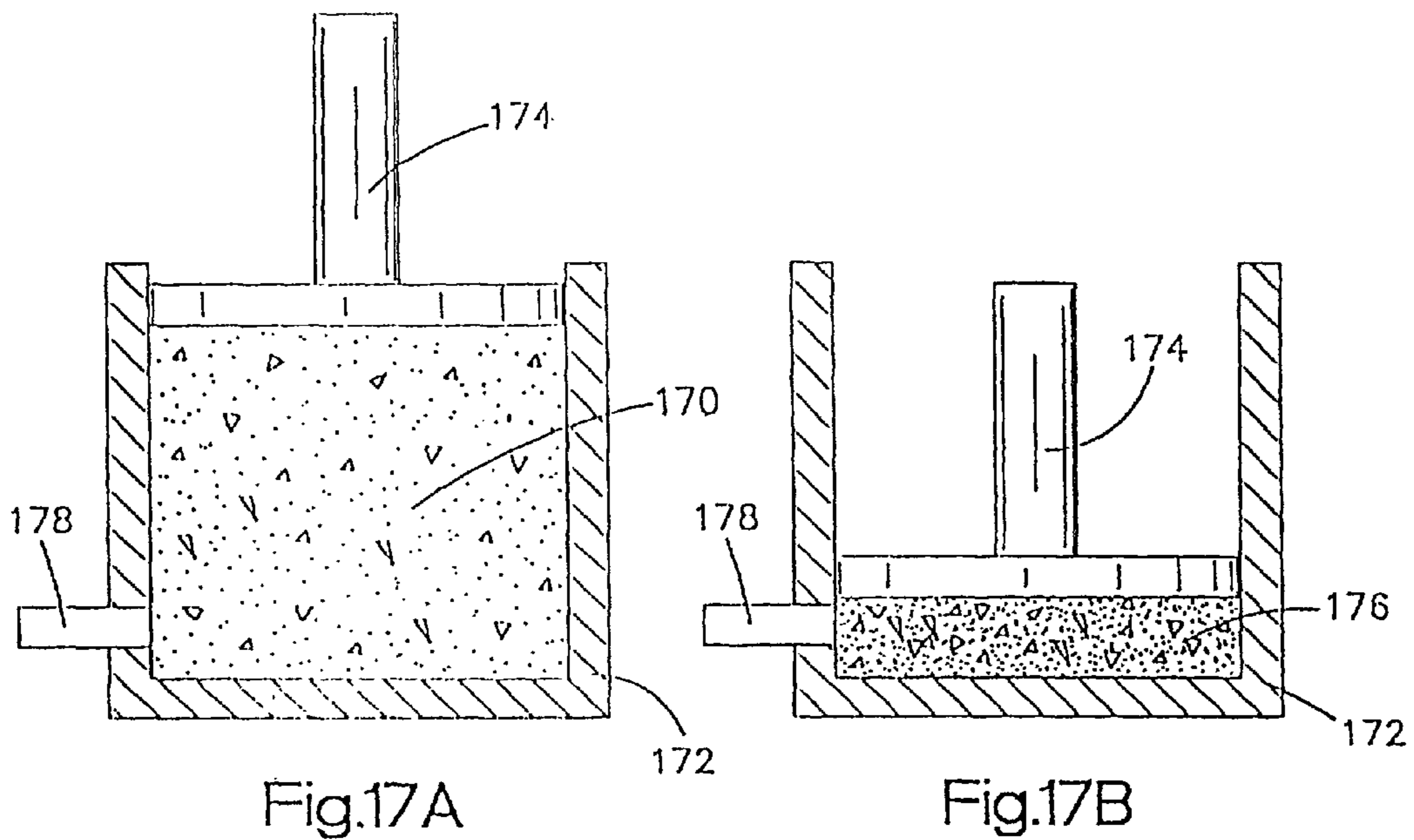
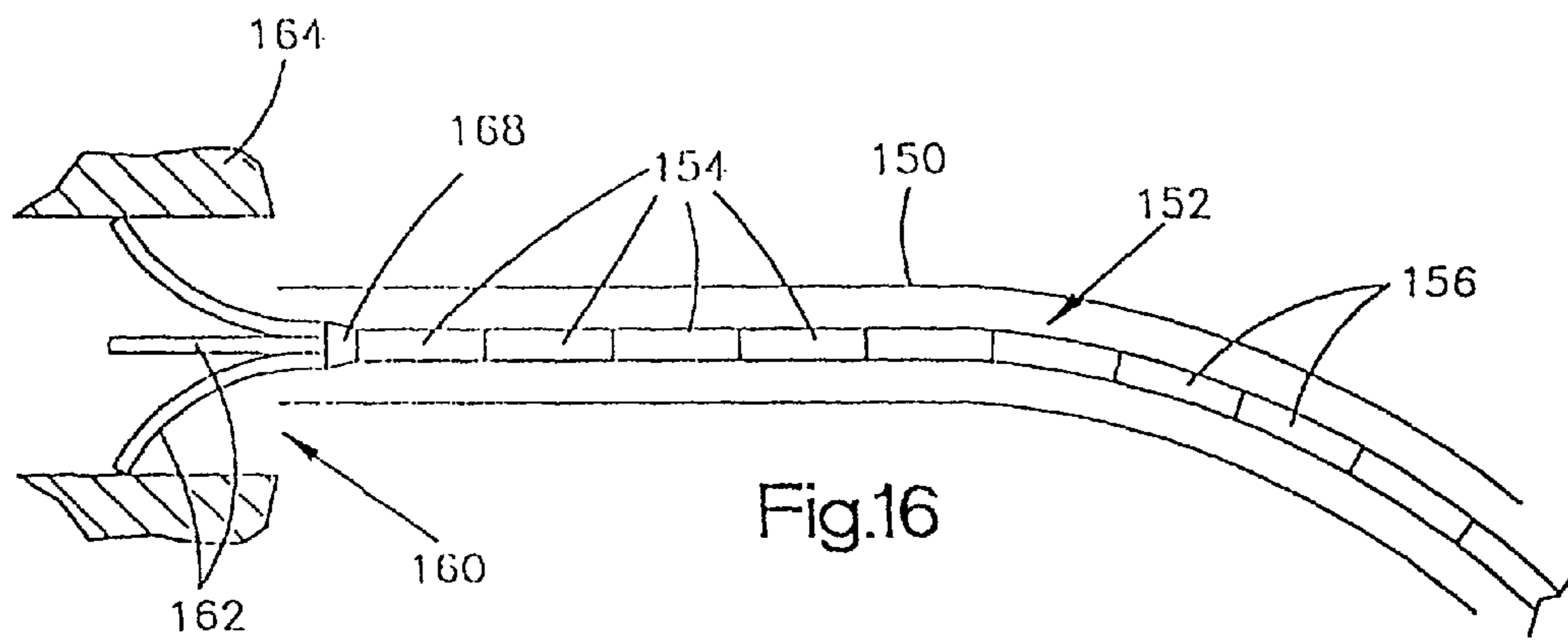
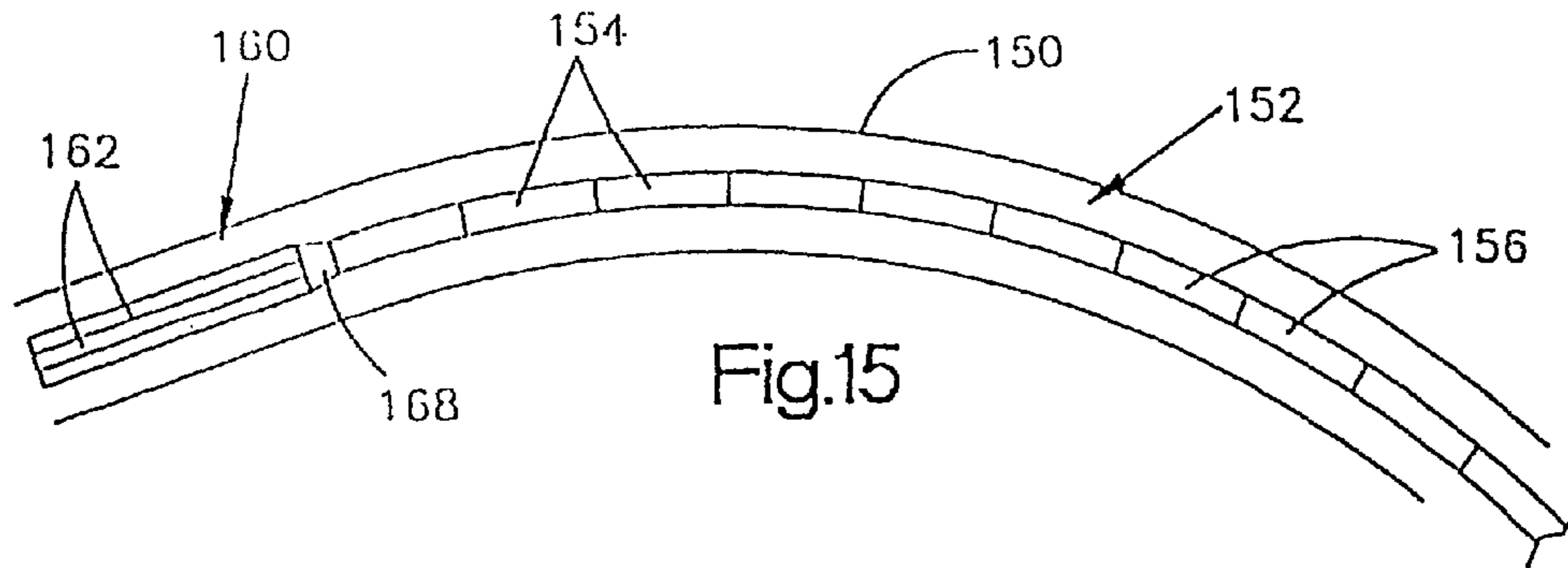

Fig.18

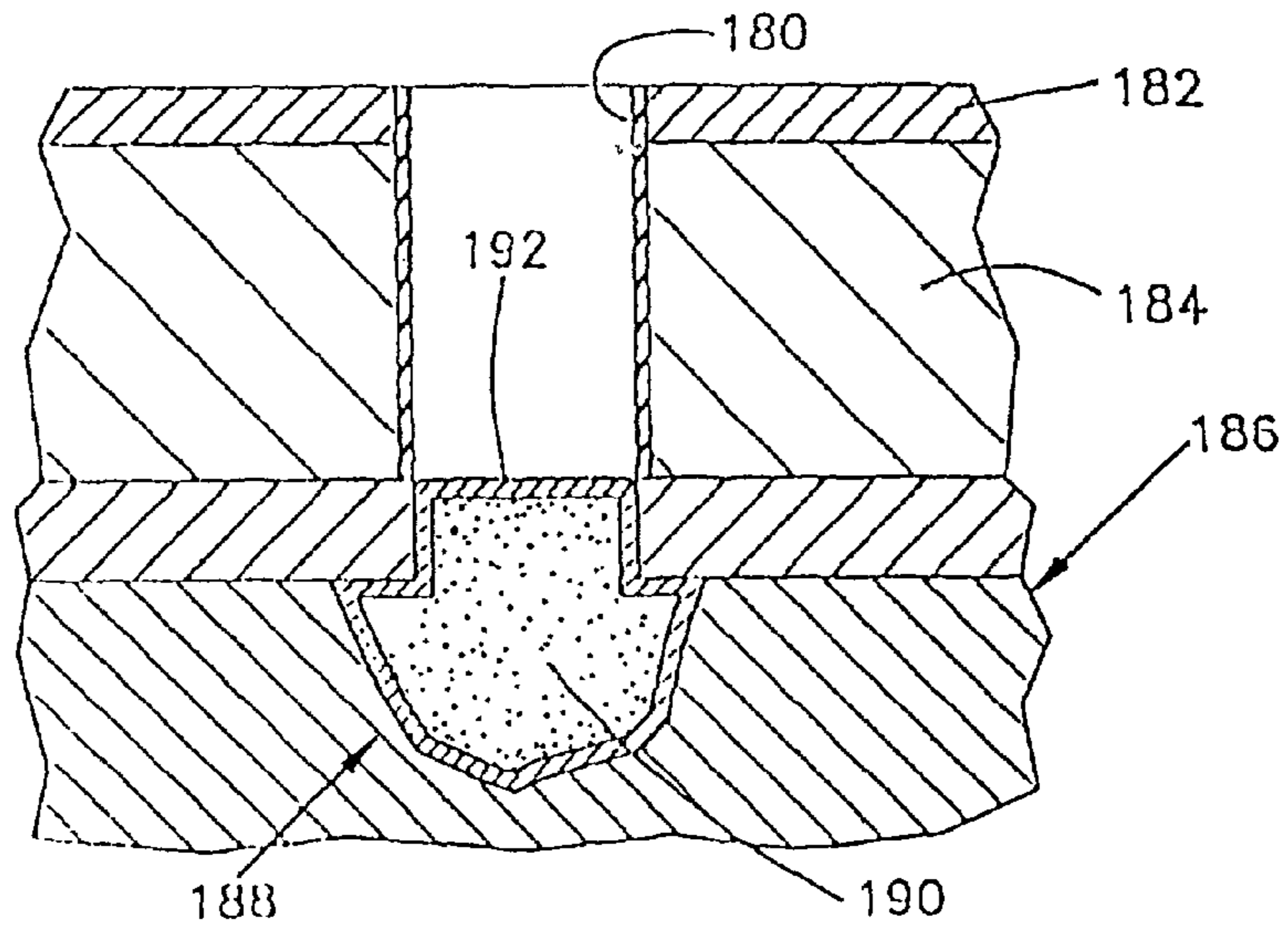

Fig.19A

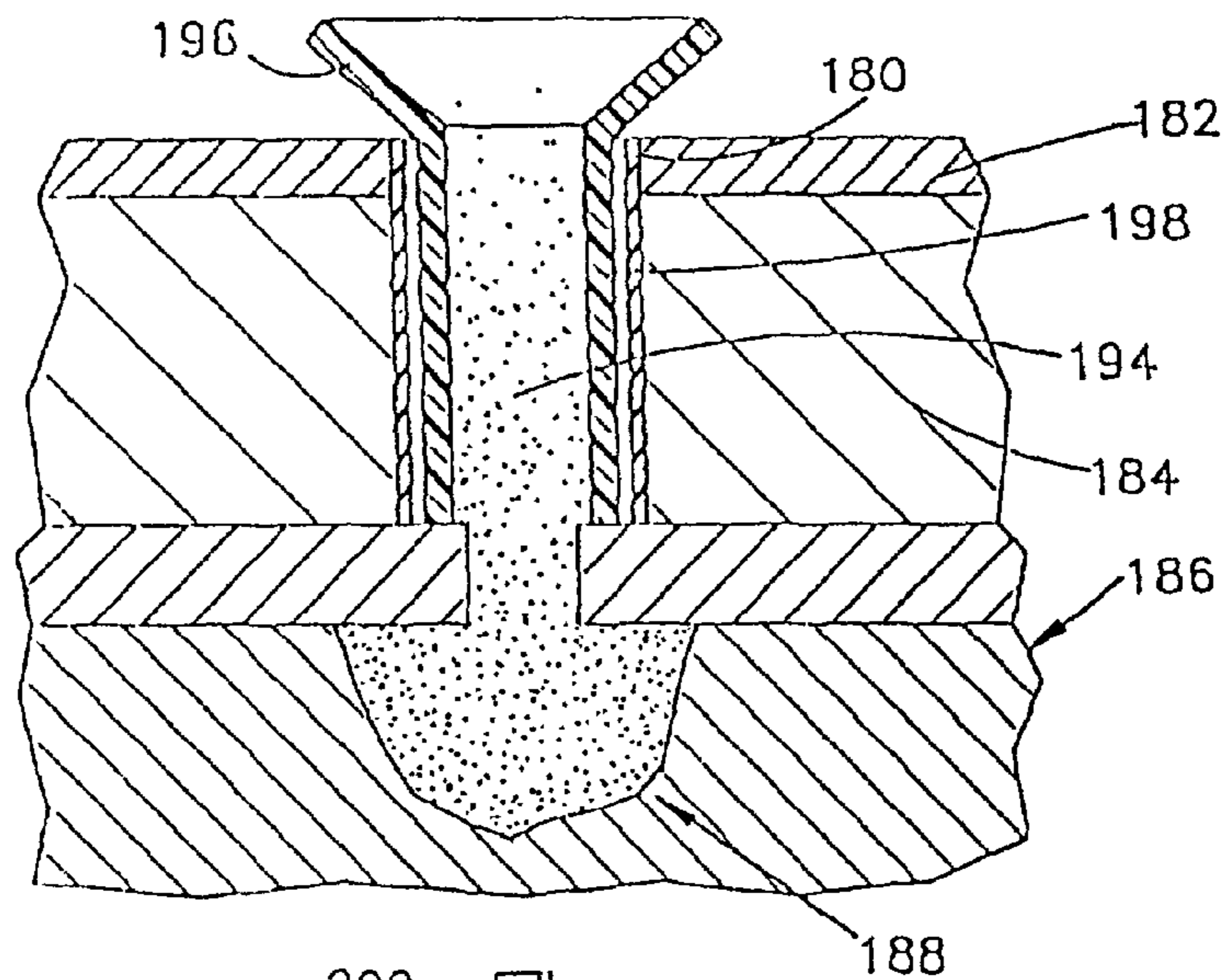
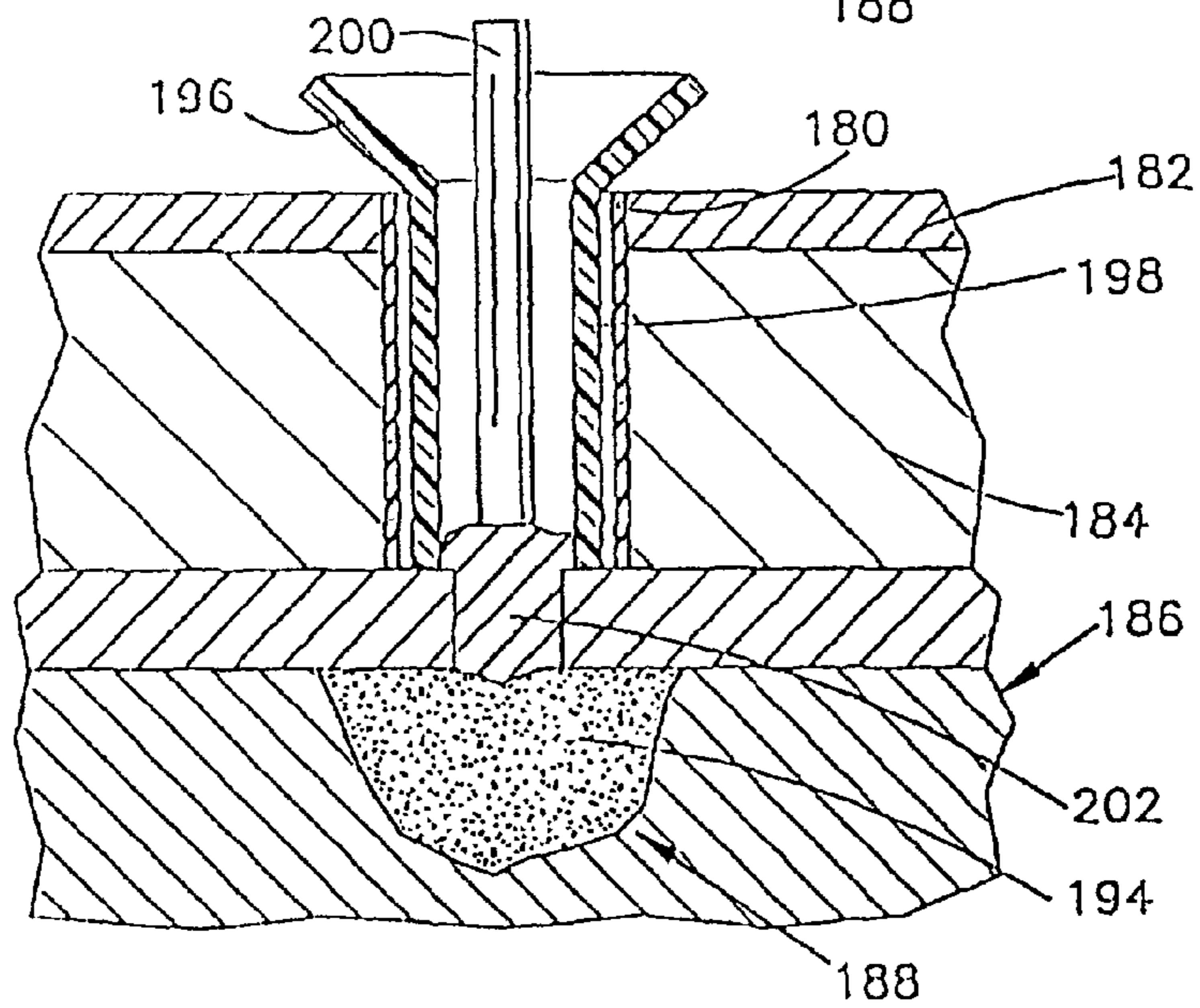

Fig.19B



APPARATUS AND METHOD FOR TISSUE REMOVAL

RELATED APPLICATIONS

This application is a continuation of U.S. patent application Ser. No. 09/483,676, filed Jan. 14, 2000, now U.S. Pat. No. 6,468,289. The aforementioned application Ser. No. 09/483,676 is itself a continuation of U.S. patent application Ser. No. 09/323,326 filed Jun. 1, 1999, (now U.S. Pat. No. 6,174,313). The aforementioned application Ser. No. 09/323,326 is a continuation of U.S. patent application Ser. No. 08/834,835 filed Apr. 11, 1997, now U.S. Pat. No. 5,935,131. The aforementioned application Ser. No. 08/834,835 is itself a divisional of U.S. patent application Ser. No. 08/695,274 filed Aug. 9, 1996, (now U.S. Pat. No. 5,694,951). The aforementioned application Ser. No. 08/695,274 is itself a divisional of U.S. patent application Ser. No. 08/353,494 filed on Dec. 9, 1994, (now U.S. Pat. No. 5,577,517). The aforementioned application Ser. No. 08/353,494 is itself a divisional of U.S. application Ser. No. 08/134,914 filed Oct. 12, 1993 (now U.S. Pat. No. 5,403,317). The aforementioned application Ser. No. 08/134,914 filed Oct. 12, 1993 is itself a divisional of U.S. application Ser. No. 07/545,908 filed Jun. 28, 1990 (now U.S. Pat. No. 5,269,785). The benefit of the earlier filing dates of the aforementioned application Ser. Nos. 09/483,676; 09/323,326; 08/834,835; 08/695,274; 08/353,494; 08/134,914 and 07/545,908 is hereby claimed.

BACKGROUND OF THE INVENTION

1. Technical Field

The present invention relates to the field of tissue removal and tissue grafting. More particularly, the present invention relates to an apparatus and method for the percutaneous cutting and removal of selected portions of tissue from a patient and the possible harvesting and implantation of the tissue portion in the donor.

2. Description of the Prior Art

There are various known methods and apparatus for the cutting and removal of tissue fragments from a human. Each of these, however, suffers from one or more deficiencies.

U.S. Pat. No. 4,832,683 shows an instrument for ultrasonic cutting of bones, with irrigation or suction. However, there is no suction while cutting, no removal of the cut bone or tissue, and no flexibility in the instrument.

U.S. Pat. No. 4,265,231 shows apparatus for drilling a curved hole having a flexible shaft confined in a rigid tubular sheath, but which shows no removal of cut bone or tissue.

U.S. Pat. No. 4,541,423 shows apparatus for drilling a curved hole having a flexible shaft confined in a semi-rigid tubular sheath, but which shows no removal of cut bone or tissue.

U.S. Pat. No. 4,589,414 shows a surgical cutting instrument with a reciprocating cutting motion, but which has no removal of cut bone or tissue, and no flexibility in the instrument.

U.S. Pat. No. 4,603,694 shows a rotating arthroscopic shaver with suction, but which is not flexible and which has no removal of cut bone or tissue.

U.S. Pat. No. 4,751,922 shows a flexible medullary reamer with a plastic shaft and a guide rod, but which has no suction and no removal of the cut bone or tissue.

U.S. Pat. Nos. 4,798,213, 4,649,918, and 4,142,517 show various apparatus for bone coring.

SUMMARY OF THE INVENTION

The present invention is a percutaneous tissue removal apparatus including a flexible drill shaft and means for trans-

mitting motion to the shaft. A cutting tip is mounted on the shaft to cut tissue fragments from the tissue. The tissue fragments are removed by suction along the flexible drill shaft to a location outside the body while cutting. One or more selected components of the removed tissue fragments may be collected for implantation, preferably into the body of the patient from whom they were removed. Because the drill shaft is flexible, the surgeon can guide the cutting tip into various locations within the tissue from a small (percutaneous) incision. The surgeon can cut around arcs or angles, rather than only being able to go in a straight line, to reach any desired location, and to avoid vital tissue which would otherwise be in the cutting path. For example, when removing unwanted tissue inside a knee joint the drill shaft can deform, and is therefore less likely to damage normal tissue or joint surfaces. None of these functions is possible with a straight line system.

GENERAL DESCRIPTION OF THE INVENTION

The present invention is a percutaneous tissue removal device and method. In the preferred embodiments described below, the apparatus and method are illustrated as used for removal of bone tissue, but such description is for illustrative purposes only. The invention is not limited to the removal of bone tissue and may be used for removal of cartilage, muscle, fetal tissue, etc. It may be used to break up and remove kidney stones, in the gall bladder for a stone or tumor, in the stomach, in the colon to remove a polyp or tumor, etc. It can reach spaces not currently available with the straight line systems currently available.

A percutaneous tissue removal apparatus in accordance with the present invention includes a flexible drill shaft for insertion inside a tissue. A cutting tip is mounted on the drill shaft for cutting the tissue. Either rotating motion or reciprocating motion is transmitted to the drill shaft to move the cutting tip against the tissue to cut tissue fragments from the tissue. While cutting, the tissue fragments are removed by suction to a location outside the body. The drill shaft and cutting tip are small enough to be usable percutaneously. They may also be used for endoscopic, arthroscopic or fiberoptic or open surgery.

Because the drill shaft is flexible, the surgeon can guide the cutting tip into various locations within the tissue from one percutaneous incision. The surgeon can cut around arcs or angles, rather than only being able to go in a straight line, to reach any desired location, and to avoid vital tissue which would otherwise be in the cutting path. The flexible drill shaft also allows the surgeon when working inside a bone, for example, to keep the cutting tip away from the harder outer cortical bone and to remove only the softer inner cancellous bone. None of these features is available with the current straight line cutting devices.

The drill shaft may be made of metal, of polymeric material to reduce friction, or of a composite material. Extensive use of polymers in the drill shaft, its housing if provided, and the cutting tip area reduces friction substantially, thus requiring less energy and generating less heat within the tissue. The drill shaft is drivable by hand (for improved feel) or by motor, at variable speeds based on the need for the tissue removed.

To provide for the collection of the tissue fragments to be harvested, the removal apparatus has an axially extending suction passage along the drill shaft through which the tissue fragments are removed. The suction passage has a smooth lining to keep the tissue fragments or graft material contained and to reduce friction of the harvested tissue fragments. This lining may be the inside diameter of the flexible drill shaft

itself, or may be a separate liner sleeve which can be removed and disposed of when it becomes unsanitary or clogged, without having to remove the drill shaft and cutting tip. Alternatively, if a separate guide sleeve or guide rod is used the suction passage may be formed between the drill shaft and the guide sleeve or guide rod. In such a case, the drill shaft may be solid rather than hollow.

The cutting tip is made of a material which is harder than the material to be cut. The cutting tip may be slightly larger in diameter than the drill shaft. The cutting tip may be made of a polymeric material or a composite material. Alternatively, the cutting tip may be made of a ceramic material. The cutting tip is separable from the drill shaft, and several different cutting tips may be provided in varying hardnesses, so that the surgeon can selectively remove various portions of tissue as desired.

By virtue of its flexibility, the flexible drill shaft, when removing bone tissue, may stay within the cortical confines of the bone. Alternatively, it may work with a guide device to control the location of the cutting tip within the bone. The guide means may be a guide rod extending within the flexible drill shaft, or a hollow guide sleeve outside the flexible drill shaft. The guide rod or guide sleeve may be rigid in a particular shape, to fit a particular application; or it may be bendable into a particular shape which it will hold; or it may be selectively rigidifiable into a particular shape in situ. The guide means may include structure for positioning the tip of the flexible drill shaft. The guide means may also be inserted into a separate flexible tube system to guide it to a specific location, then removed, allowing the flexible drill to be inserted.

Fluid may be injected through the flexible drill shaft to a location adjacent the cutting tip to increase the efficiency of the tissue removal and to limit thermal necrosis. Alternatively, a fluid injection passage may extend axially along the flexible drill shaft, the drill shaft. Alternatively, fluid may be injected through the suction passage, alternating with the suction. The fluid injection may be constant or it may be pulsatile in nature. If fluid injection is used, centrifuging of the harvested material may be performed.

Means for collecting one or more selected components of the harvested tissue fragments may include a known trap or filter connected to the outlet of the suction passage. Removed tissue may be centrifuged to separate its components. Thus, the tissue fragments are not merely removed from the body and may be harvested for implantation of the fragments, preferably into the body of the patient from whom they were removed. In order to maintain the sterility of the tissue removed, the entire suction apparatus including the suction passage and the trap or filter is sterilized, and, if necessary, is disposable.

With the present invention all work is done by going percutaneously through the skin to a specific tissue area to minimize the damage to skin, muscle, and bone. For example, when removing bone tissue, trauma is limited to a small opening in the hard outer structural cortical bone, limiting postoperative bleeding from the bone which is difficult to stop, because the small operative hole can easily be plugged after the grafting procedure is completed, preventing postoperative bleeding into soft tissue. There is only intraosseous bleeding, so that fewer complications, and less pain, are likely to arise. The operation does not create stress risers which would weaken the bone. Thus, the present invention provides a safe and efficient way to collect and reuse a patient's own tissue.

Human tissue grafting works best using the patient's own tissue as donor material. Therefore, the harvested tissue may be implanted in the donor's own body for grafting. To implant

one or more selected components of harvested bone fragments, for example, a cannula is inserted through the skin and muscle to the area of the bone where the graft is to be placed. A drill or curette is then used to remove a portion of the outer cortical bone. A curette or probe is inserted through the cannula to clear out the area where the graft is to be placed, either in open surgery or through X-ray guidance in percutaneous surgery. The harvested tissue fragments may be packed or compressed into a plug of tissue graft material, of a specific shape, with or without blood or fibrin for adhesion. Or, a retaining material such as a biodegradable mesh may be used to hold the graft material together as a unit. The graft material and its retaining material are then inserted at the graft location in the bone. Alternatively, the graft material is inserted and then sealed in place with a mass of formable polymeric material inserted over the graft material to hold the graft together in position.

A method of percutaneous tissue removal in accordance with the present invention includes the steps of placing within a tissue mass a flexible drill shaft having mounted thereon a cutting tip for cutting the tissue; transmitting motion to the drill shaft to move the cutting tip against the tissue to cut tissue fragments from the tissue; and removing the tissue fragments by suction to a location outside the tissue mass while cutting the tissue. The method may further include the step of controlling the location of the cutting tip within the tissue with a guide rod, the step of collecting one or more selected components of the harvested tissue fragments, and/or the step of implanting the fragments into the body of the patient from whom they were removed.

BRIEF DESCRIPTION OF THE DRAWINGS

Further features of the present invention will become apparent to those skilled in the art to which the present invention relates from reading the following specification with reference to the accompanying drawings, in which:

FIG. 1 is a schematic view of a tissue removal system in accordance with the present invention and including a flexible drill;

FIG. 2 is a schematic view of a hand-powered flexible drill for use in the system of FIG. 1;

FIG. 3 is a schematic view of a portion of a hollow flexible drive shaft for the flexible drill;

FIG. 4 is a schematic view similar to FIG. 3 and showing a guide rod inside the hollow flexible drive shaft;

FIG. 5 illustrates a portion of a flexible drill including a hollow flexible inner cutting shaft within a flexible outer sleeve and a suction passage between the two shafts;

FIG. 6 is a view similar to FIG. 5 with a suction passage within the inner shaft;

FIG. 7 illustrates a portion of a flexible drill including a solid flexible inner cutting shaft within a flexible outer sleeve and a suction passage between the two shafts;

FIG. 8 illustrates a portion of a flexible drill including a solid formable inner guide rod within a flexible outer cutting sleeve and a suction passage between;

FIG. 9 illustrates a portion of a flexible drill including a hollow flexible inner cutting shaft within a solid formable outer sleeve and a suction passage between;

FIG. 10 is a view similar to FIG. 9 with a suction passage within the inner shaft;

FIG. 11 illustrates a portion of a flexible drill including a solid flexible inner cutting shaft within a solid formable outer sleeve and a suction passage between;

5

FIG. 12 illustrates a portion of a flexible drill including a relatively flexible portion between two relatively rigid portions;

FIG. 13 illustrates the use of a liner sleeve in a suction passage;

FIG. 14 is a view illustrating a number of different cutting tips usable with the flexible drill;

FIGS. 15 and 16 are schematic views illustrating the provision of a plurality of separately inflatable bladders as a guide mechanism for a flexible structure and the operation of a guidance system for locating the tip of the flexible structure;

FIGS. 17A and 17B are schematic views illustrating the forming of harvested tissue fragments into a compressed plug suitable for implantation;

FIG. 18 is a schematic view illustrating the implantation of harvested bone fragments using a polymeric mesh as a retainer; and

FIGS. 19A and 19B are schematic views illustrating the implantation of harvested tissue fragments using a formable polymeric sealant as a retainer.

DESCRIPTION OF PREFERRED EMBODIMENTS

The present invention is described herein with reference to a percutaneous bone removal and harvesting apparatus and method. It should be understood that the present invention is not limited to the removal of bone tissue, but is useful in the removal of any hard or soft tissue in the body such as excess, unwanted, or tumorous tissue or tissue used for reimplantation or grating.

A percutaneous bone removal apparatus 10 (FIG. 1) in accordance with the present invention includes a flexible drill 12. The flexible drill 12 has a flexible shaft 14 and a cutting tip 16 at the distal end of the shaft 14. The proximal end of the flexible shaft 14 is connected by a housing 18 to a motor or other power source 20 to provide rotational motion or reciprocating motion in a manner known in the art. Alternatively, the drill 12 may have an angled drive, such as 90° drive or any angle, with the motor drive connected at an angle to the longitudinal extent of the suction and cutting apparatus.

Control means indicated schematically at 21 may include one or more switches or valves to turn on or off the suction, irrigation, and motor drive. Control A fluid injection source 22 is connected by a fluid injection line 24 to the housing 18 of the flexible drill 12. A suction source 26 acts through a trap or filter or strainer 28 and a suction line 30 to provide suction capabilities for the flexible drill 12.

FIG. 2 illustrates a flexible drill 12a in which the housing 18a is connected to a hand controller 20a. The hand controller 20a allows the surgeon to operate the flexible drill 12a by hand, imparting either rotational or reciprocating movement to the flexible shaft 14a and cutting tip 16a.

FIG. 3 illustrates a portion of a basic version of a flexible drill having a cutting tip 16 mounted on a flexible drive shaft 31. The drive shaft 31 has an outer surface 32 and an inner surface 34 defining a longitudinally extending suction passage 36. The cutting tip 16 has a cutting edge 40 and an opening 38 through which tissue fragments cut by the cutting tip 16 may be aspirated. The tissue fragments are drawn through the suction passage 36 in the flexible drive shaft 31 and thence into the suction line 30 (FIG. 1) for collection in the trap or filter or strainer 28.

FIG. 4 illustrates the use of a pre-inserted guide rod 42 with a flexible drill of the present invention. The guide rod 42 extends through the suction passage 36 of the flexible drive shaft 31. The guide rod 42 may be any suitable structure

6

including a K-wire or other known device. The cutting tip 16 may have a centrally located opening in its distal end to allow insertion of the flexible drill over the guide rod 42. The guide rod 42 is first placed in the body, then the flexible drill is inserted over the guide rod 42 and guided to the location from which tissue is to be harvested.

FIG. 5 illustrates an embodiment of a flexible drill having an outer sleeve 44 circumscribing a flexible drill shaft 41. The flexible outer sleeve 44 may be formed of a metal or composite material or may be formed of a polymeric material which may be the same as or different from the material of the flexible inner cutting shaft 31. The outer sleeve 44 is fixed (non-moving) to minimize tissue damage. A suction passage 46 is defined between the outer surface of the flexible inner shaft 31 to which the cutting tip is attached, and the inner surface of the flexible outer sleeve 44. Alternatively, as shown in FIG. 6, a suction passage 48 may be defined within the flexible inner cutting shaft 50. In this case, the outer surface of the flexible inner shaft 50 is preferably, as illustrated in FIG. 6, in close proximity to the inner surface of the outer sleeve 44 to increase stability. The use of polymeric materials for both the inner shaft 50 and the outer sleeve 44 provides for reduced friction between the sleeve 44 and the shaft 50 for ease of operation and reduced heat generation.

FIG. 7 illustrates an alternate embodiment of the apparatus of FIG. 5 in which the flexible inner cutting shaft 52 is formed as a solid shaft rather than a hollow shaft. The harvested tissue fragments travel through the suction passage 46 between the inner shaft 52 and the outer sleeve 44.

FIG. 8 illustrates apparatus similar to FIG. 7 in which a fixed (non-moving) inner shaft 54 is made of a solid, formable, material and the cutting tip is mounted on a flexible rotating outer sleeve 56. Suction is drawn through a suction passage 58 between the shaft 54 and the sleeve 56. The inner shaft 54 is made from a semi-rigid material which is bendable to a desired curvature, at the use site, to select the curvature of the hole to be drilled, and which is rigid enough to retain that curvature in use while the drill shaft 56 rotates around it. Such material is disclosed in U.S. Pat. No. 4,541,423, the disclosure of which is incorporated herein by reference.

FIGS. 9, 10 and 11 illustrate embodiments of the flexible drill of the present invention in which a flexible inner cutting shaft, which may be hollow or solid, is disposed within a non-moving formable outer sleeve. The formable outer sleeve 60 is made of a semi-rigid bendable shape retaining material as described above with reference to FIG. 8. In FIG. 9, a hollow flexible inner cutting shaft 62 is disposed within the outer sleeve 60 and defines therebetween a suction passage 64. In FIG. 10, a hollow flexible inner cutting shaft 66 is disposed in close proximity to and within the outer sleeve 60, with a suction passage 68 formed within the flexible inner cutting shaft 66. In FIG. 11, a solid flexible inner cutting shaft 70 is disposed within the outer sleeve 60, defining therebetween a suction passage 72.

FIG. 12 illustrates a portion of a flexible drill shaft 80 in accordance with the present invention in which a pair of relatively rigid drill portions 82 and 84 are joined by a relatively flexible drill portion 86. The relatively rigid drill portion 82 includes an outer sleeve 88, an inner shaft 90, and a suction passage 92 therebetween. The relatively rigid drill portion 84 includes an outer sleeve 94 like the outer sleeve 88, an inner shaft 96 like the inner shaft 90, and a suction passage 98 therebetween. The drill portion 86 includes a relatively flexible inner shaft portion 100 disposed within a relatively flexible outer sleeve portion 102, defining therebetween a suction passage 104. The relatively flexible inner shaft portion 100 connects the relatively rigid inner shaft portions 90

and **96**. The relatively flexible outer sleeve portion **102** connects the relatively rigid outer sleeve portions **88** and **94**. The suction passage **104** in the relatively flexible drill shaft portion **86** connects the suction passages **92** and **98**. Either the inner shaft or the outer sleeve of the flexible drill **80** may have a cutting tip mounted thereon. Thus, with a flexible drill shaft made in this manner, it is not necessary that the entire drill shaft be made of flexible materials, but rather “joints” such as are formed by the relatively flexible portion **86** may be placed along the longitudinal extent of a relatively rigid drill shaft as desired.

FIG. **13** illustrates how a disposable single-use liner sleeve **110** may be used in a flexible drill of the present invention. The liner sleeve **110** shown in FIG. **13** is located within an outer sleeve **112** and is shown about a guide rod or guide wire **114**. Suction is drawn through a passage **116** within the liner sleeve **110**. The disposable single-use liner sleeve **110** provides an absolutely sterile environment through which harvested tissue fragments may pass. The inner surface **118** of the liner sleeve **110** is extremely smooth in order to facilitate passage of the harvested tissue fragments therethrough. It should be understood that a liner sleeve like the liner sleeve **110** may be used with any suitable flexible drill shaft configuration in accordance with the present invention, and not merely with the configuration shown in FIG. **13**.

FIG. **14** illustrates several different cutting tips which may be attached in a known manner to a flexible drill shaft in accordance with the present invention. The technology for the cutting tips is not specific to the present invention, but rather the cutting tips may be designed in accordance with known principles.

The cutting tip **120** (FIG. **14**) has a cutting edge **122** at least partially defining an opening **123** through which suction is drawn. The cutting tip **124** includes a plurality of cutting edges **126** defining a plurality of suction openings **128** disposed along the outer circumferential portion of the cutting tip **124**. The cutting tip **130** is similar to the cutting tip **124** but includes cutting edges **126a** and suction openings **128a** which extend to the end of the cutting tip **130**. Furthermore, the cutting tip **130** is blunt rather than sharp, to avoid perforation of tissue, such as bones.

The cutting tip **132** has a spiral cutting edge **134** defining a spiral suction opening **136**. The cutting tip **138** has at least one longitudinally extending cutting edge **140** at least partially defining a longitudinally extending suction opening **142**. The cutting tip **143** is formed as a burr with fluted cutting edges **144** and suction openings **145**, and is especially suited for shaving operations such as removal of bone spurs, etc. The cutting tip **146** has twin cutting edges **147** and **148** and a suction opening **149**. The cutting edges **157** and **148** can be configured with the leading edge to grab the tissue and the trailing edge to cut the tissue.

The configuration of a cutting tip for use in accordance with the present invention is a design choice within the skill of the art. The goals to be met are proper cutting and suction capabilities, controllability and shape so as to avoid unwanted damage to areas of tissue not to be cut. For example, when removing the softer cancellous portion of bone, the cutting tip may be made of a material which is harder than the cancellous material of the bone but softer than the cortical portion of the bone to avoid damage thereto. Metal may be useful, and suitable polymers are also readily available. Ceramic materials and composites are also suitable. Also, the cutting tip may be arranged as a rotating flexible shaft within a fixed flexible outer shaft, with a cutting edge on the rotating shaft to cut tissue off against the fixed edge. In such a case, the apparatus

may be advantageously configured with one shaft being metal and the other polymeric, to minimize friction and heat buildup.

FIGS. **15** and **16** illustrate an alternate guidance system for positioning a flexible drill shaft **150** and its associated cutting tip. Disposed within the sleeve **150** is a guidance mechanism **152** including a plurality of inflatable elements spaced serially. The inflatable elements, when inflated, rigidify and become straight, while when in the deflated condition they are soft and flexible and may be curved or bent. Thus, as seen in FIG. **15**, both the inflatable elements designated **154** and the inflatable elements **156** are curved. In FIG. **16**, the inflatable elements **154** have rigidified and straightened, while the inflatable elements **156** remain in their curved position. The inflatable elements may also be accordion shaped, expanding in length as they are inflated. The mechanism **152** may be augmented with a known cable guidance system.

By selectively and individually controlling the rigidification of any or all of the inflatable elements of the mechanism **152**, the inflatable mechanism **152** and its associated outer sleeve **150** may be selectively formed into almost any desired shape or position. Suitable control and valving apparatus is provided for controlling the inflation of the inflatable elements. Such apparatus may be, when only a few elements are present, a simple mechanical valving apparatus. When more elements are present, or more sophisticated or complex control thereof is desired, a microprocessor may be used to control the inflation of each segment. Separate inflation and deflation lines can be used, or one line can, by alternating valving, serve both functions. In such case, the control signals may be multiplexed down the structure via electric wire, optical fiber, or radio control, for example.

At the distal end of the mechanism **152** is a tip guidance mechanism **160** including a plurality of inflatable members **162**. The inflatable members **162** when in a deflated condition are flexible and relatively straight. When inflated, as shown in FIG. **16**, the members **162** assume a preformed shape which may be curved or straight and which is illustrated herein as a curved shape, bending radially outwardly to engage the surface of adjacent tissue **164** and curve the end of the device into an appropriate position. The members **162** may be constructed, using known principles, to assume any desired shape. By controlling the positioning of one or more of the elements **162**, the tip portion **168** of the guidance mechanism **152** may be selectively placed in any position relative to the tissue **164**, thus positioning the end of the sleeve **150**. The air bladder guidance system as described may be used in conjunction with a flexible tube separate from the flexible drill shaft, order to guide the flexible tube to a specific location and position it there, thereafter removing the guidance system and allowing a flexible drill to be inserted.

Means for collecting one or more selected components of the harvested tissue fragments includes a mechanism **28** (FIG. **1**) which may be a known trap or filter connected to the outlet of the suction passage **30**. Removed tissue may also be centrifuged if necessary or desired, keeping the components such as bone, cells, and blood and discarding fluid. These components and connections, and their uses, are well known in the art and thus are not described herein in greater detail. The harvested tissue fragments are not merely removed from the body of the patient, but are also collected in the structure **28** and thus harvested or saved for later implantation of the fragments, preferably into the body of the patient from whom they were removed. Such harvesting and implantation are desirable because human tissue grafting works best using the patient's own tissue as donor material.

In preparing the harvested graft material for implantation, the tissue fragments alone are spun or compressed (see FIG. 17) to form them into the desired shape. When the tissue is harvested, blood and blood clots are often drawn along with the tissue fragments. The blood component fibrin is a sticky clotting component, and can be used to aid in holding the tissue fragments together for implantation. Thus, the blood can be separated from the tissue fragments and then spun to separate the fibrin for use with the tissue fragments. Alternatively, the entire mass of tissue fragments and blood is compressed into a specific shape to form the mass into a specific, appropriate shape for implantation into the body.

The surgeon can also place other substances into the graft material to be implanted, such as other tissue graft material, collagen, antibiotics, or ceramic hydroxyapatite or tricalcium phosphate to aid in bone ingrowth. In such a case, when the blood or fibrin is used also, the graft has the adhesive qualities of the blood or fibrin and the biological properties of the bone (or other) tissue, along with the appropriate medical properties of any other material included.

Harvested tissue fragments before implantation are preferably packed or compressed into a plug of tissue graft material. Alternatively, the tissue fragments may be left in a more loose state, or only certain selected cells, components, or tissue fragments are used. Any suitable means of packing or compressing fragments may be used. FIG. 17 illustrates schematically a simple apparatus for doing so. As viewed in FIG. 17, the harvested tissue pieces 170 are placed into a form or mold 172 and then compressed by a movable compressor 174 to form a plug 176 of a desired shape or size. Unwanted fluid drains out through one or more fluid outlets 178, while the graft, cells, fibrin, and blood clot tissues remain within the form 172.

To implant one or more selected components of the harvested tissue fragments, for example in grafting bone tissue onto a bone, a cannula 180 is inserted through the skin 182 and muscle 184 to the area of the bone 186 where the graft is to be placed. A curette or probe is then inserted through the cannula 182 to clear out the area 188 where the graft is to be placed.

The harvested tissue fragments are compacted or compressed into a plug 190 of tissue graft material. A retaining material such as a known biodegradable or other polymeric mesh 192 is then used to hold the graft material 190 together as a unit. The retaining material may also be a sac of biodegradable material used to hold the graft material. The sac can be closed by a clamp or by crimping or heat sealing. The graft material 190 and its retaining material 192 are then inserted into the graft area of the bone. The cannula 180 may then be removed. Alternatively, the tissue graft material may be held in place by a mass of biodegradable or other polymeric material used as a sealant for the opening in the bone 186. The graft material can be compressed or spun into a specific shape. Thus, if an implant is needed to fit a specific shape of bone defect, the graft material can be formed in the shape needed and packed directly into the bone gap.

The bone graft material may also be implanted in the loose condition as described above. The bone graft material 194, if loose, can be inserted through a funnel 196 and a sleeve 198 located within the cannula 180, to the area 188 to be grafted. It is then packed in place as desired using a suitable instrument. Next, an injector 200 is used to inject a mass of flowable biodegradable or other polymeric material 202 for use as a sealant to seal the bone graft material 194 in position. The use of a flowable biodegradable material is preferable in that it allows the surgeon to form in situ a custom shaped sealant

plug to seal the opening in the tissue graft area, which will eventually resorb as new tissue grows into its place.

The apparatus may include, as noted above, fluid injection means 22 and 24 for injecting fluid through the flexible drill to a location adjacent the cutting tip to aid in cutting and removal of the harvested tissue fragments. For example, in the drill shaft structure illustrated in FIG. 5, fluid may be injected through a fluid injection passage 204 within the flexible inner cutting shaft 31, while suction is drawn in the opposite direction through the suction passage 46. Alternatively, the suction may be intermittently discontinued and fluid may be injected through the suction passage, alternating with the suction. The fluid injection may be constant or it may be pulsatile in nature.

The present invention thus provides a method of percutaneous tissue removal which includes the steps of placing adjacent to a tissue mass a flexible drill shaft 14 having mounted thereon a cutting tip 16 for cutting the tissue; transmitting motion to the drill shaft 14 to move the cutting tip 16 against the tissue to cut tissue fragments from the tissue; and removing the tissue fragments by suction to a location outside the tissue mass while cutting the tissue. The method may further include the step of controlling the location of the cutting tip within the tissue with a guide mechanism, the step of collecting one or more selected components of the harvested tissue fragments, and/or the step of implanting the fragments into the body of the patient from whom they were removed.

From the above description of the invention, those skilled in the art will perceive improvements, changes and modifications. Such improvements, changes and modifications within the skill of the art are intended to be covered by the appended claims.

I claim:

1. A surgical procedure to be conducted on a patient, said surgical procedure comprising the steps of removing tissue from a first location in the patient's body, separating one or more components from at least a portion of the removed tissue, thereafter packing the removed tissue into a desired shape, and thereafter implanting the packed tissue at a second location in the patient's body, wherein the removed tissue includes blood and other body tissue.

2. A surgical procedure as set forth in claim 1 wherein said step of separating one or more components from the removed tissue includes centrifuging at least a portion of the removed tissue.

3. A surgical procedure as set forth in claim 1 further including the step of adding a substance to the removed tissue after separating one or more components from the removed tissue and prior to implanting the packed tissue at a second location in the patient's body.

4. A surgical procedure as set forth in claim 1 wherein said step of removing tissue from a first location in a patient's body includes cutting body tissue at the first location and moving the body tissue away from the first location under the influence of suction.

5. A surgical procedure as set forth in claim 1 wherein said step of separating one or more components from the removed tissue includes separating one or more components from blood removed from the patient's body, said step of implanting the packed tissue at a second location in the patient's body includes implanting one or more components of the blood removed from the patient's body.

6. A surgical procedure as set forth in claim 1 wherein said step of separating one or more components from the removed tissue includes separating at least a first component from blood removed from the patient's body, said step of implanting the packed tissue at a second location in the patient's body

11

includes implanting the blood removed from the patient's body after removing at least the first component from the blood and implanting at least a portion of the other body tissue removed from the patient's body.

7. A surgical procedure as set forth in claim 1 wherein said step of separating one or more components from the removed tissue includes removing at least a first component from the blood removed from the patient's body, and said step of implanting the packed tissue at the second location includes implanting at least the blood from which at least the first component has been removed.

8. A surgical procedure as set forth in claim 1 wherein said step of separating one or more components from the removed tissue includes filtering the blood and other body tissue removed from the first location, said step of implanting the packed tissue at a second location is performed after filtering the blood and other body tissue removed from the first location.

9. A surgical procedure as set forth in claim 1 wherein said step of separating one or more components from the removed tissue includes moving the blood and other body tissue removed from the first location into a trap, said step of implanting the packed tissue at a second location is performed after moving the blood and other body tissue removed from the first location into the trap.

10. A surgical procedure as set forth in claim 1 wherein said step of removing tissue from a first location in a patient's body includes inserting a first tubular member into a patient's body and moving the removed tissue from the first location in the patient's body through the first tubular member to a location outside of the patient's body, said step of implanting the packed tissue at a second location in the patient's body includes inserting a second tubular member into the patient's body and moving the packed tissue through the second tubular member.

11. A surgical procedure to be conducted on a patient, said surgical procedure comprising the steps of inserting a first tubular member into the patient's body, moving body tissue from a first location in the patient's body through the first tubular member to a location outside of the patient's body, inserting a second tubular member into the patient's body, and moving at least a portion of the body tissue through the second tubular member to a second location in the patient's body, wherein a substance is added to the body tissue after moving the body tissue from the first location through the first tubular member to a location outside of the patient's body and prior to moving the body tissue through the second tubular member; wherein the added substance is a bone growth promoter; and wherein said step separating one or more components from at least a portion of the tissue, wherein said step of moving body tissue from the first location in the patient's body through the first tubular member includes moving blood from the first location in the patient's body through the first tubular member, and surgical procedure further includes separating one or more components from the blood, said step of moving body tissue through the second tubular member to the second location in the patient's body includes moving the blood from which one or more components have been removed through the second tubular member to the second location in the patient's body.

12. A Surgical procedure as set forth in claim 11 wherein said step of moving tissue from the first location in the patient's body through a first tubular member includes moving blood and pieces of other tissue through the first tubular member, said surgical procedure further includes filtering the blood and other tissue moved through the first tubular mem-

12

ber, said step of moving body tissue through the second tubular member is performed after filtering the blood and other tissue.

13. A surgical procedure as set forth in claim 11 wherein said step of moving tissue from the first location in the patient's body through a first tubular member includes moving blood and pieces of other tissue through the first tubular member, said surgical procedure further includes moving the blood and other tissue into a trap, said step of moving body tissue through the second tubular member is performed after moving the blood and other tissue into a trap.

14. The surgical procedure according to claim 11, which further comprises:

inserting a cutting tool via said first tubular member to the body tissue; and reciprocating said cutting tool to cut the body tissue.

15. The surgical procedure according to claim 11, which further comprises:

inserting a cutting tool via said first tubular member to the body tissue; and rotating said cutting tool to cut the body tissue.

16. The surgical procedure according to claim 11, wherein said first tubular member includes a material selected from the group consisting of a metal, a polymer, and a composite.

17. The surgical procedure according to claim 11, which further comprises:

inserting a cutting tool through said first tubular member to the body tissue; cutting the body tissue with said cutting tool; and driving said cutting tool manually.

18. The surgical procedure according to claim 11, which further comprises:

inserting a cutting tool through said first tubular member to the body tissue; cutting the body tissue with said cutting tool; and driving said cutting tool with a motor.

19. The surgical procedure according to claim 11, which further comprises guiding said first tubular member to the body tissue.

20. The surgical procedure according to claim 19, which further comprises inserting a means for guiding said first tubular member to the body tissue before inserting said tubular member.

21. The surgical procedure according to claim 20, wherein said means for guiding said first tubular member to the body tissue is selected from the group consisting of a guide rod and a guide wire.

22. The surgical procedure according to claim 20, wherein said means for guiding said first tubular member is at least partially within said tubular member.

23. The surgical procedure according to claim 20, wherein said means for guiding said first tubular member is outside of said first tubular member.

24. A surgical procedure to be conducted on a patient, said surgical procedure comprising the steps of cutting body tissue at a first location in a patient's body, moving blood and other body tissue along a first tubular member in a direction away from the first location in the patient's body to a location outside of the patient's body, separating one or more components from at least one of the blood and other body tissue at a location outside of the patient's body, thereafter, packing the blood and other body tissue to form a packed tissue mass, moving the packed tissue mass along a second tubular member in a direction toward a second location in the patient's body, and implanting the packed tissue mass at the second location in the patient's body.

13

25. A surgical procedure as set forth in claim 24 wherein said step of separating one or more components from at least one of the blood and other body tissue includes centrifuging the blood.

26. A surgical procedure as set forth in claim 24 further including the step of adding a substance to the packed tissue mass prior to moving the packed tissue mass along the second tubular member.

27. A surgical procedure as set forth in claim 24 wherein said step of moving the packed tissue mass along a first tubular member includes moving the packed tissue mass under the influence of suction.

28. A surgical procedure as set forth in claim 24 wherein said step of cutting body tissue at the first location in a patient's body includes rotating a cutting tool under the influence of force transmitting through the first tubular member.

29. A surgical procedure as set forth in claim 24 further including the steps of moving a surgical instrument through the second tubular member and removing the tissue from the second location before moving the packed tissue mass along the second tubular member.

30. A surgical procedure to be conducted on a patient, said surgical procedure comprising the steps of cutting body tissue at a first location in a patient's body, moving blood and other body tissue along a first tubular member in a direction away from the first location in the patient's body to a location outside of the patient's body, separating one or more components from at least one of the blood and other body tissue at a location outside of the patient's body, thereafter, moving the blood and other body tissue along a second tubular member in a direction toward a second location in the patient's body, and implanting the blood and other body tissue at the second location in the patient's body wherein said step of separating one or more components from at least one of the blood and other body tissue includes centrifuging the other body tissue.

31. The surgical procedure according to claim 30, which further comprises:

inserting a cutting tool via said first tubular member to the body tissue; and
reciprocating said cutting tool to cut the body tissue.

14

32. The surgical procedure according to claim 30, which further comprises:

inserting a cutting tool via said first tubular member to the body tissue; and

rotating said cutting tool to cut the body tissue.

33. The surgical procedure according to claim 30, wherein said first tubular member includes a material selected from the group consisting of a metal, a polymer, and a composite.

34. The surgical procedure according to claim 30, which further comprises:

inserting a cutting tool through said first tubular member to the body tissue;

performing the cutting of the body tissue with said cutting tool; and

driving said cutting tool manually.

35. The surgical procedure according to claim 30, which further comprises:

inserting a cutting tool through said first tubular member to the body tissue;

performing the cutting of the body tissue with said cutting tool; and

driving said cutting tool with a motor.

36. The surgical procedure according to claim 30, which further comprises guiding said first tubular member to the body tissue.

37. The surgical procedure according to claim 36, which further comprises inserting a means for guiding said first tubular member to the body tissue before inserting said tubular member.

38. The surgical procedure according to claim 37, wherein said means for guiding said first tubular member to the body tissue is selected from the group consisting of a guide rod and a guide wire.

39. The surgical procedure according to claim 37, wherein said means for guiding said first tubular member is at least partially within said tubular member.

40. The surgical procedure according to claim 37, wherein said means for guiding said first tubular member is outside of said first tubular member.

* * * * *