

US007891242B2

(12) **United States Patent**  
**Cheng et al.**

(10) **Patent No.:** **US 7,891,242 B2**  
(45) **Date of Patent:** **Feb. 22, 2011**

(54) **SENSING DEVICE**

(75) Inventors: **Pi-Ying Cheng**, Hsinchu (TW);  
**Kian-Poh Wong**, Johor (MY)

(73) Assignee: **National Chiao Tung University**,  
Hsinchu (TW)

5,308,098 A 5/1994 Shea  
5,423,563 A 6/1995 Wild  
5,577,567 A 11/1996 Johnson  
5,676,215 A 10/1997 Misawa  
5,701,965 A 12/1997 Kamen  
5,868,403 A 2/1999 Culp

(\*) Notice: Subject to any disclaimer, the term of this patent is extended or adjusted under 35 U.S.C. 154(b) by 518 days.

(Continued)

FOREIGN PATENT DOCUMENTS

(21) Appl. No.: **12/027,488**

TW 134144 5/1990

(22) Filed: **Feb. 7, 2008**

(65) **Prior Publication Data**

US 2008/0271528 A1 Nov. 6, 2008

(Continued)

(30) **Foreign Application Priority Data**

May 2, 2007 (TW) ..... 96115622 A

*Primary Examiner*—Hezron Williams

*Assistant Examiner*—Alex Devito

(74) *Attorney, Agent, or Firm*—Muncy, Geissler, Olds & Lowe, PLLC

(51) **Int. Cl.**

**G01F 23/26** (2006.01)

(57)

**ABSTRACT**

(52) **U.S. Cl.** ..... **73/304 R**

(58) **Field of Classification Search** ..... **73/304 R**  
See application file for complete search history.

The present invention discloses a sensing device, wherein a hemispherical container containing a liquid dielectric, and the hemispherical container has more than two pairs of electrodes, and the liquid dielectric can trigger the conduction states of the electrodes. A corrosion-resistant material envelops the container. A precision valve is arranged in the container and used to adjust the level of the liquid dielectric and the sensitivity of the sensing device. A buffer necking part is also arranged in the container and used to prevent from non-expected vibration-induced contact between the electrodes and the liquid dielectric. A leakage-proof detection device envelops the hemispherical container, the liquid dielectric, the precision valve, and the buffer necking part and functions to prevent from the leakage of the liquid dielectric. Thus, the present invention can provide an adjustable multi-directional tilt-sensing device for level control.

(56) **References Cited**

U.S. PATENT DOCUMENTS

3,484,829 A 12/1969 Erickson  
4,421,189 A 12/1983 Watkins  
4,473,234 A 9/1984 Egen  
4,532,968 A \* 8/1985 Leonard ..... 141/5  
4,566,706 A 1/1986 Bihler  
4,569,409 A 2/1986 Kluth  
4,790,548 A 12/1988 Decelles  
4,919,489 A 4/1990 Kopsco  
4,962,941 A 10/1990 Rembos  
5,020,818 A 6/1991 Oxford  
5,158,309 A 10/1992 Quigg  
5,197,558 A 3/1993 Misawa  
5,263,547 A 11/1993 Alber  
5,273,296 A 12/1993 Lepek

**10 Claims, 4 Drawing Sheets**

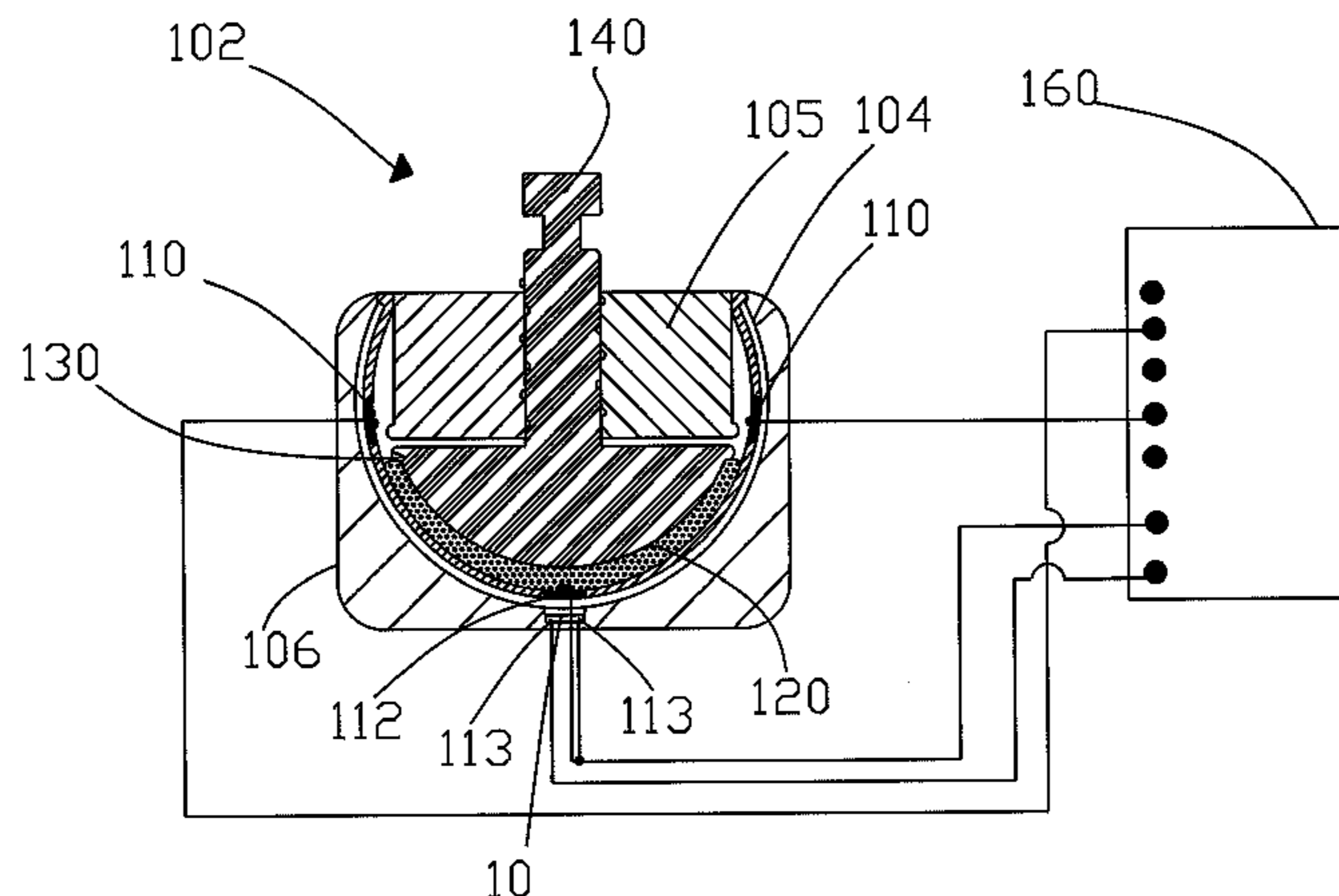

# US 7,891,242 B2

Page 2

---

## U.S. PATENT DOCUMENTS

5,971,091	A	10/1999	Kamen	
5,975,225	A	11/1999	Kamen	
6,282,804	B1 *	9/2001	Jiang .....	33/366.21
6,325,167	B1	12/2001	Jiang	
6,328,120	B1	12/2001	Haussler	
6,341,784	B1	1/2002	Carstens	
6,343,664	B2	2/2002	Morrell	
6,415,879	B2	7/2002	Kamen	
6,422,576	B1	7/2002	Michaeli	
6,443,250	B1	9/2002	Kamen	
6,443,251	B1	9/2002	Morrell	
6,550,787	B1	4/2003	Chu	
6,615,938	B2	9/2003	Morrell	
6,619,414	B2	9/2003	Rau	
6,644,426	B1	11/2003	Larue	

6,799,649 B2 10/2004 Kamen

## FOREIGN PATENT DOCUMENTS

TW	204495	4/1993
TW	226782	7/1994
TW	301605	4/1997
TW	329964	4/1998
TW	350328	1/1999
TW	437388	5/2001
TW	472137	1/2002
TW	502863	9/2002
TW	511657	11/2002
TW	522137	3/2003
TW	567159	12/2003
TW	M241637	8/2004
TW	M286664	2/2006
TW	M289015	3/2006

\* cited by examiner



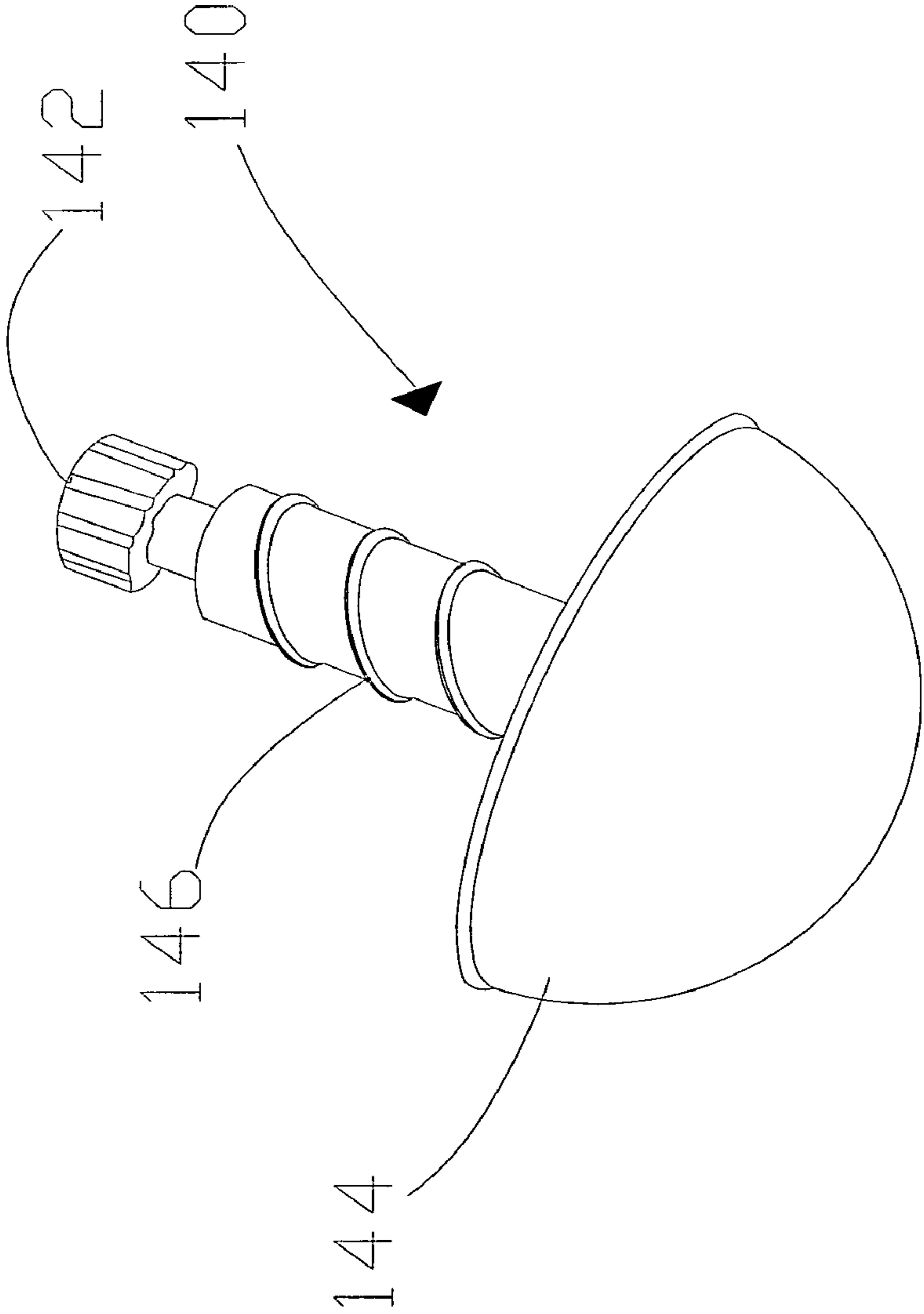

Fig. 2

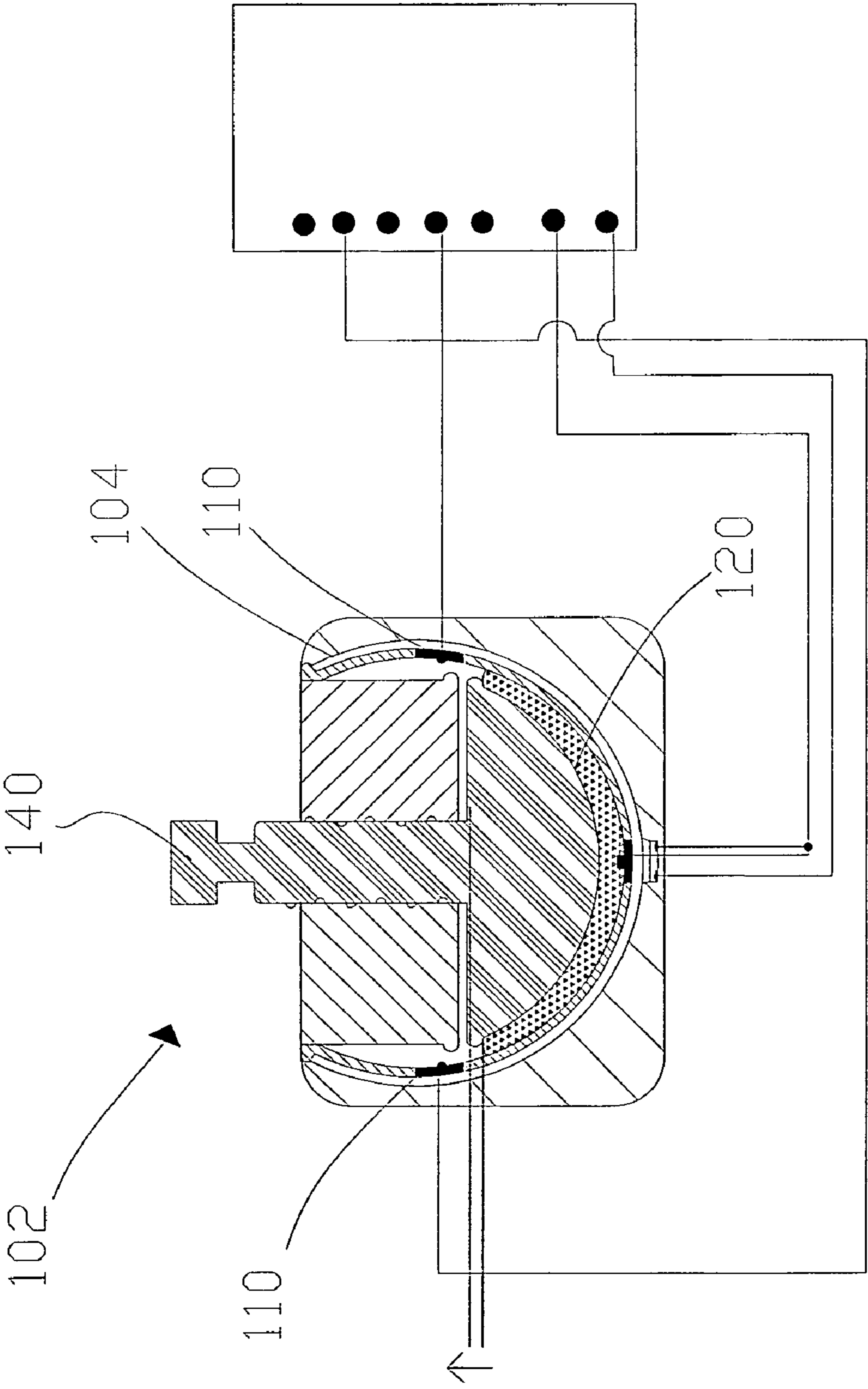

Fig. 3



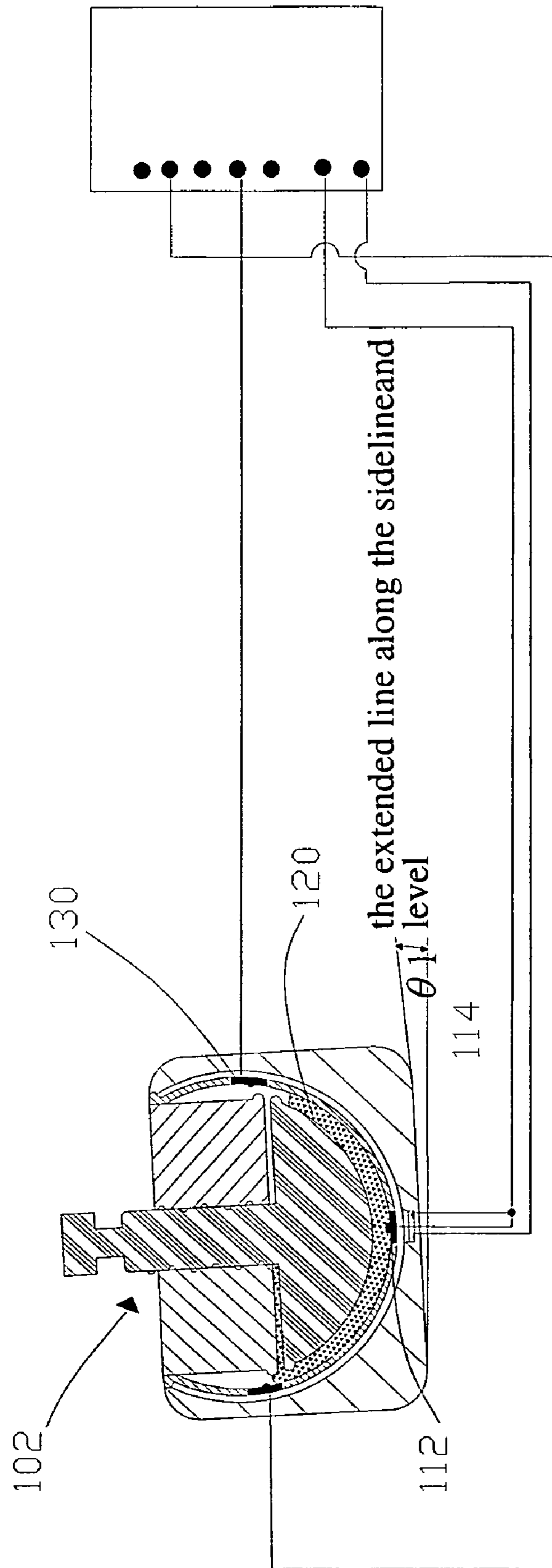

Fig. 4

# 1

## SENSING DEVICE

### BACKGROUND OF THE INVENTION

#### 1. Field of the Invention

The present invention relates to a sensing device, particularly to a multi-directional tilt-sensing device.

#### 2. Description of the Related Art

In a conventional sensing device, mercury and wires are sealed in a glass tube, wherein the wires function as fixed contacts, and mercury functions as a movable contact. As mercury is a liquid, tilt will cause mercury to move and results in that the fixed contact of the wire is submerged in mercury. Thus, the conventional sensor can function as a control switch. However, such a sensor cannot perform multi-directional control but can only function as a unidirectional switch.

Thus, a multi-directional mercury switch was proposed to overcome the disadvantage of the abovementioned sensor that can only detect unidirectional vibration or inclination. For example, a Taiwan patent No. 226782 proposed an improved mercury switch, which can detect vibration or inclination multi-directionally. In the conventional technology, two conductive pillars are shaped into two rings and arranged inside a glass body. The two rings are equidistantly separated and appropriately arranged along the inner wall of the glass body. The glass body is a disc-like body and has slightly-coned upper and lower surfaces, wherein the height of the glass body gradually decreases from the central protrusion to the perimeter. When the glass body is horizontally placed, mercury is at the center. When the glass body tilts, mercury contacts two conductive pillars, and a signal is thus sent out. Such a conventional technology can indeed achieve multi-directional detection. However, the conduction of the electrodes may be triggered by a slight vibration or inclination. Further, the sensitivity of the switch is unadjustable. When such a switch is used to adjust a movable platform, it may be too sensitive.

Accordingly, the present invention proposes a sensing device to solve the abovementioned problems.

### SUMMARY OF THE INVENTION

The primary objective of the present invention is to provide a sensing device, wherein a container containing a liquid dielectric and at least two pairs of electrodes are used to implement an adjustable multi-directional tilt-sensing device for level control.

Another objective of the present invention is to provide a sensing device, wherein the sensitivity of the sensing device can be controlled by a precision valve.

Further objective of the present invention is to provide a sensing device, wherein a leakage-proof detection device functions as the second defense line for liquid dielectric leakage.

To achieve the abovementioned objectives, the present invention proposes a sensing device, wherein a hemispherical container is used to contain a liquid dielectric, and a corrosion-resistant material envelops the hemispherical container; two pairs of electrodes are arranged inside the hemispherical container and used to switch the conduction states of a circuit; the hemispherical container has a precision valve used to regulate the level of the liquid dielectric; the hemispherical container has a buffer necking part used to avoid non-expected vibration-induced contact between the electrodes and the liquid dielectric; a leakage-proof detection device envelops the hemispherical container, the liquid dielectric, the

# 2

buffer necking part and the precision valve and functions as the second defense line against liquid dielectric leakage.

Below, the embodiments are to be described in detail in cooperation with the attached drawings to make easily understood the objectives, technical contents, characteristics and accomplishments of the present invention.

### BRIEF DESCRIPTION OF THE DRAWINGS

FIG. 1 is a sectional view of a sensing device according to the present invention;

FIG. 2 is a diagram schematically showing a precision valve according to the present invention;

FIG. 3 is a sectional view of a precision valve according to the present invention; and

FIG. 4 is a diagram schematically showing a sensing device in a tilt state according to the present invention.

### DETAILED DESCRIPTION OF THE INVENTION

Refer to FIG. 1, a sectional view of a sensing device according to the present invention is shown. In the sensing device **102** of the present invention, a hemispherical container **104** contains a liquid dielectric **120**, and a corrosion-resistant material envelops the container **104**. The liquid dielectric may be mercury. At least two pairs of contact electrodes **110** are arranged on two sides of the container **104**. At least one bottom electrode **112** is arranged in the bottom of the container **104**. A circuit connection module **160** is arranged inside the container **104** and used to separate the positive and negative electrodes of the contact electrodes **110** and the bottom electrode **112** lest short circuit occur. The container **104** is fixedly installed inside a leakage-proof detection device **106**. The leakage-proof detection device **106** is used to prevent from the harm of liquid dielectric leakage caused by an accident. In addition to the above-mentioned hemispherical container, the container of the sensing device of the present invention may also adopt other shapes to meet different requirements.

Refer to FIG. 2 and FIG. 3. The container **104** further comprises a precision valve **140**. The precision valve **140** has a thread **146**, which cooperates with an inner thread of a fixing element **105** to secure the precision valve **140** to the container **104**. One end of the precision valve **140** has a rotary knob **142**, and the other end has a cone **144**. The rotation of the rotary knob **142** can drive the cone **144** to move up or down. As the cone **144** is partially submerged in the liquid dielectric **120**, the vertical movement of the cone **144** will change the level of the liquid dielectric **120**. The higher the level of the liquid dielectric **120**, the smaller the difference between the height of the contact electrode **110** and the height of the liquid dielectric **120**, and the smaller the tilt angle required to make the liquid dielectric **120** contact the contact electrode **110**, and thus the greater the sensitivity to tilt. Contrarily, the lower the level of the liquid dielectric **120**, the greater the difference between the height of the contact electrode **110** and the height of the liquid dielectric **120**, and the greater the tilt angle required to make the liquid dielectric **120** contact the contact electrode **110**, and thus the smaller the sensitivity to tilt.

Refer to FIG. 1. A leakage-proof detection device **106**, which is in the form of an external casing and has a groove **10** at the bottom thereof, is used to envelops the container **104**, the liquid dielectric **120**, the buffer necking part **130**, the precision valve **140** and functions as the second defense line against the leakage of the liquid dielectric **120**. A sensing electrode **113** is arranged in the groove **10**. When there is a leakage, the liquid dielectric **120** will flow along the inner



3

wall of the leakage-proof detection device **106** to the groove **10**, which will trigger the sensing electrode **113** to send signal to the user or to start necessary safety facilities.

Refer to FIG. **4** a diagram schematically showing a sensing device in a tilt state according to the present invention. When the sensing device of the present invention is attached to a carrier, and when the support seat of the carrier tilts, a part of the contact electrodes **110** contact the liquid dielectric **120**. Thus, the liquid dielectric **120** electrically interconnects the contact electrodes **110** and the bottom electrode **112**. Therefore, an angle  $\theta_1$  is contained between the level of the liquid dielectric **120** and the extended line along the sideline and can be used to detect the tilt state of a platform and facilitate restoring the support seat back to the horizontal state. As the inner wall of the container **104** has at least two pairs of contact electrodes **110**, the sensing device of the present invention can detect tilt multi-directionally. The buffer necking part **130** in the container **104** is designed to eliminate the influence of surface tension and to avoid the non-expected vibration-induced contact between the contact electrode **110** and the liquid dielectric **120** during movement. Those described above are the embodiments to exemplify the present invention to enable the persons skilled in the art to understand, make and use the present invention. However, it is not intended to limit the scope of the present invention. Any equivalent modification or variation according to the spirit of the present invention is to be also included within the scope of the claims stated below.

What is claimed is:

**1.** A sensing device comprising:

a container having a fixing element and at least two pairs of electrodes;

a liquid dielectric contained by said container and used to trigger said electrodes in said container and switch conduction states of a circuit;

a bottom electrode arranged at bottom of said container and used to detect leakage of said liquid dielectric;

a buffer necking part located inside said container, arranged along a perimeter of the bottom of said fixing element and used to prevent said liquid dielectric from contacting said electrodes;

a precision valve arranged in said container, penetrating said fixing element with a part thereof emerging from said fixing element and used to adjust level of said liquid

4

dielectric, wherein a high level results in a high sensitivity, and a low level results in a low sensitivity; and a leakage-proof detection device enveloping said container, said liquid dielectric, said buffer necking part and said precision valve and used to detect leakage of said liquid dielectric and prevent from leakage of said liquid dielectric.

**2.** A sensing device according to claim **1**, wherein an inner thread is formed inside said fixing element and used to fix said precision valve.

**3.** A sensing device according to claim **1**, wherein a corrosion-resistant material is used to envelop said container to provide a vibration-proof function and a collision-proof function.

**4.** A sensing device according to claim **1**, wherein said container is a hemispherical body.

**5.** A sensing device according to claim **1**, wherein said liquid dielectric is mercury.

**6.** A sensing device according to claim **1**, wherein size of said buffer necking part correlates with surface tension of said liquid dielectric.

**7.** A sensing device according to claim **1**, wherein said precision valve further comprises:

a cone arranged inside said container, submerged in said liquid dielectric and used to change level of said liquid dielectric; and

a rotary knob coupled to said cone, arranged above said fixing element and used to drive said cone to move up or down.

**8.** A sensing device according to claim **1**, wherein said leakage-proof detection device is in a form of an external casing.

**9.** A sensing device according to claim **1**, wherein a groove is formed in bottom of said leakage-proof detection device; when said liquid dielectric leaks, said liquid dielectric will flow along inner wall of said leakage-proof detection device to said groove and trigger a sensing electrode arranged in said groove to send a signal to a user or start necessary safety facilities.

**10.** A sensing device according to claim **1**, wherein said leakage-proof detection device has a sensor therein to send information about leakage of said liquid dielectric to a user or start necessary safety facilities.

\* \* \* \* \*