



US007878841B2

(12) **United States Patent**
Amidon

(10) **Patent No.:** **US 7,878,841 B2**
(45) **Date of Patent:** **Feb. 1, 2011**

(54) **PULL THROUGH MODULAR JACK AND METHOD OF USE THEREOF**

(75) Inventor: **Jeremy Amidon**, Marcellus, NY (US)

(73) Assignee: **John Mezzalingua Associates, Inc.**, E. Syracuse, NY (US)

(*) Notice: Subject to any disclaimer, the term of this patent is extended or adjusted under 35 U.S.C. 154(b) by 0 days.

6,109,943 A *	8/2000	Arnett	439/189
6,116,952 A *	9/2000	Nakata	439/587
6,250,951 B1	6/2001	Milner et al.	
6,338,643 B1	1/2002	Miller et al.	
6,364,680 B1	4/2002	Liu et al.	
6,402,561 B1	6/2002	Chen	
6,416,349 B1 *	7/2002	Lee	439/404
6,435,898 B2	8/2002	Sahlberg et al.	

(21) Appl. No.: **12/391,608**

(Continued)

(22) Filed: **Feb. 24, 2009**

FOREIGN PATENT DOCUMENTS

(65) **Prior Publication Data**
US 2010/0216331 A1 Aug. 26, 2010

JP 2004319207 11/2004

(51) **Int. Cl.**
H01R 11/20 (2006.01)

(Continued)

(52) **U.S. Cl.** **439/418; 439/405; 439/409**

OTHER PUBLICATIONS

(58) **Field of Classification Search** 439/404-405, 439/409, 417-418
See application file for complete search history.

U.S. Appl. No. 12/938,208, filed Mar. 5, 2009; Confirmation No. 9664; Customer No. 72687.

(56) **References Cited**

Primary Examiner—Truc T Nguyen

U.S. PATENT DOCUMENTS

(74) *Attorney, Agent, or Firm*—Schmeiser, Olsen & Watts, LLP

4,202,593 A	5/1980	Abernethy et al.	
4,606,595 A *	8/1986	Dola	439/404
4,648,678 A	3/1987	Archer	
4,921,436 A	5/1990	Sole et al.	
5,118,310 A	6/1992	Stroede et al.	
5,228,872 A	7/1993	Liu	
5,338,221 A *	8/1994	Bowen et al.	439/405
5,403,200 A	4/1995	Chen	
5,501,617 A	3/1996	Arnett	
5,624,274 A	4/1997	Lin	
5,626,490 A	5/1997	Pitts et al.	
5,762,518 A *	6/1998	Tanigawa et al.	439/409
5,885,111 A	3/1999	Yu	
5,899,770 A *	5/1999	Ezawa	439/418
5,980,303 A *	11/1999	Lee et al.	439/405
6,010,353 A	1/2000	Ensz et al.	
6,105,229 A	8/2000	Sullivan	

(57) **ABSTRACT**

The present invention relates to a pull-through modular jack and method of use thereof. The modular jack allows wires to be fed through the housing and pulled tight prior to terminating. This ensures that the wires terminate with the insulation displacement contact very close to the point at which the wires are still twisted. Termination is made by moving a pressing portion to a pressed position, which then pushes the wires into the insulation displacement contacts that displace the wire insulation to make contact.

13 Claims, 15 Drawing Sheets

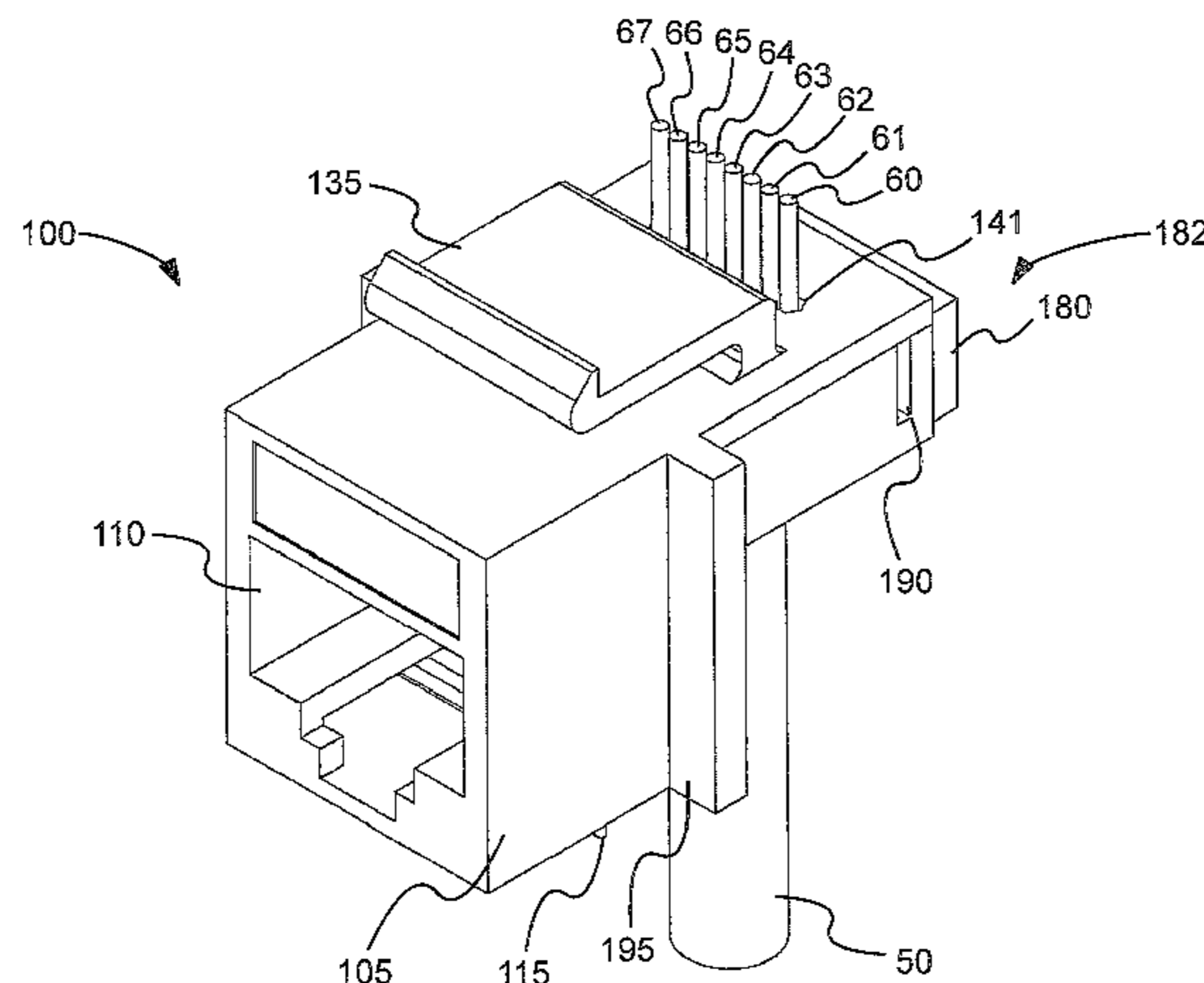

US 7,878,841 B2

Page 2

U.S. PATENT DOCUMENTS

6,561,838 B1 5/2003 Blichfeldt
6,749,456 B1 6/2004 Conner et al.
6,769,937 B1 8/2004 Roberts
6,780,063 B2 8/2004 Wang et al.
6,830,488 B2 12/2004 Bush et al.
6,890,210 B2* 5/2005 Lee 439/404
6,932,641 B1 8/2005 Liao
7,052,307 B2 5/2006 Kim et al.
7,083,472 B2 8/2006 Gordon et al.

7,097,513 B2 8/2006 Bryan
7,118,405 B2 10/2006 Peng
7,249,961 B1* 7/2007 Provenzano et al. 439/409
7,540,760 B1* 6/2009 Chen 439/409
2006/0246784 A1 11/2006 Aekins et al.
2010/0227497 A1 9/2010 Amidon

FOREIGN PATENT DOCUMENTS

JP 2006228458 8/2006

* cited by examiner

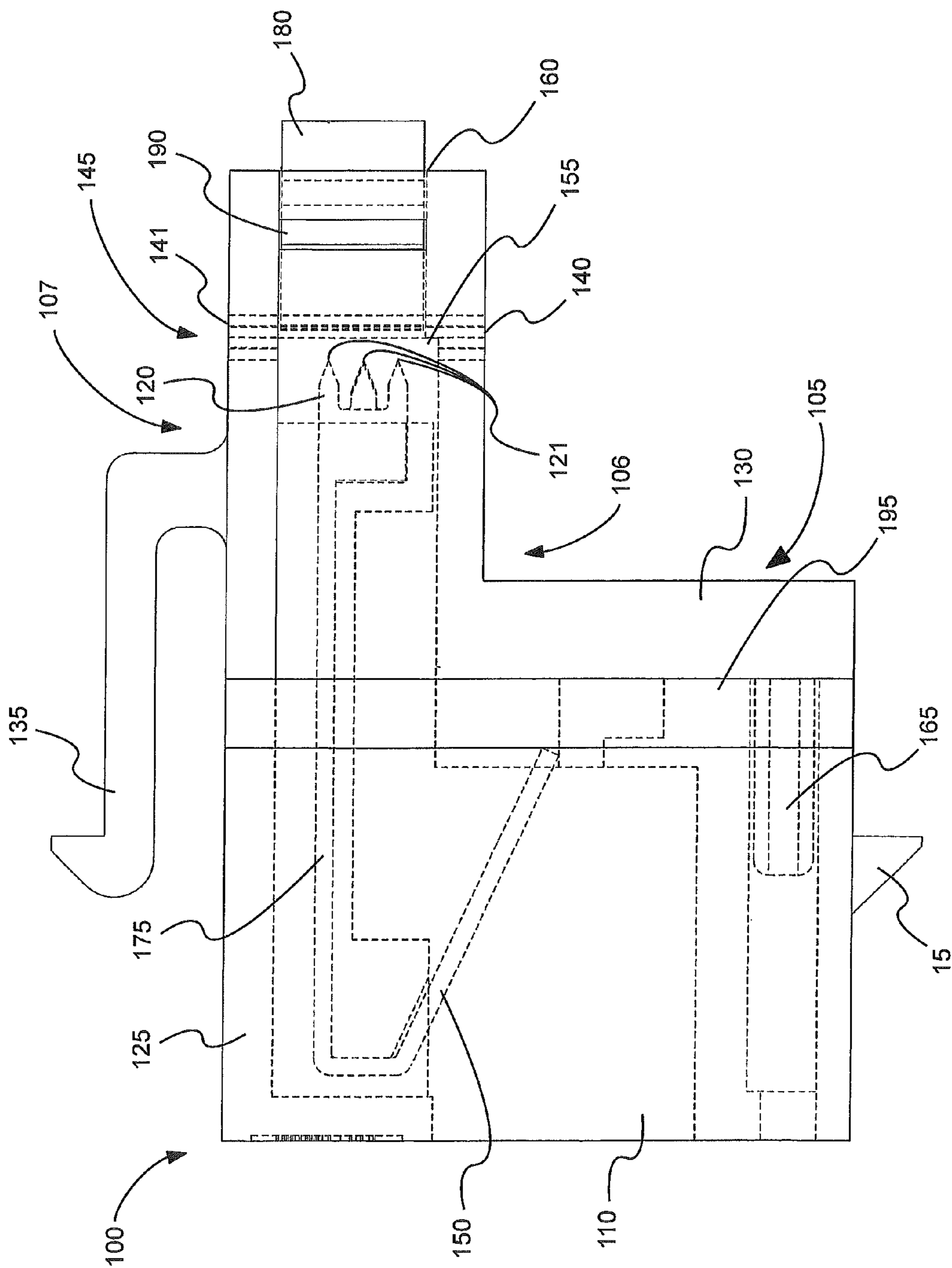

Fig. 1

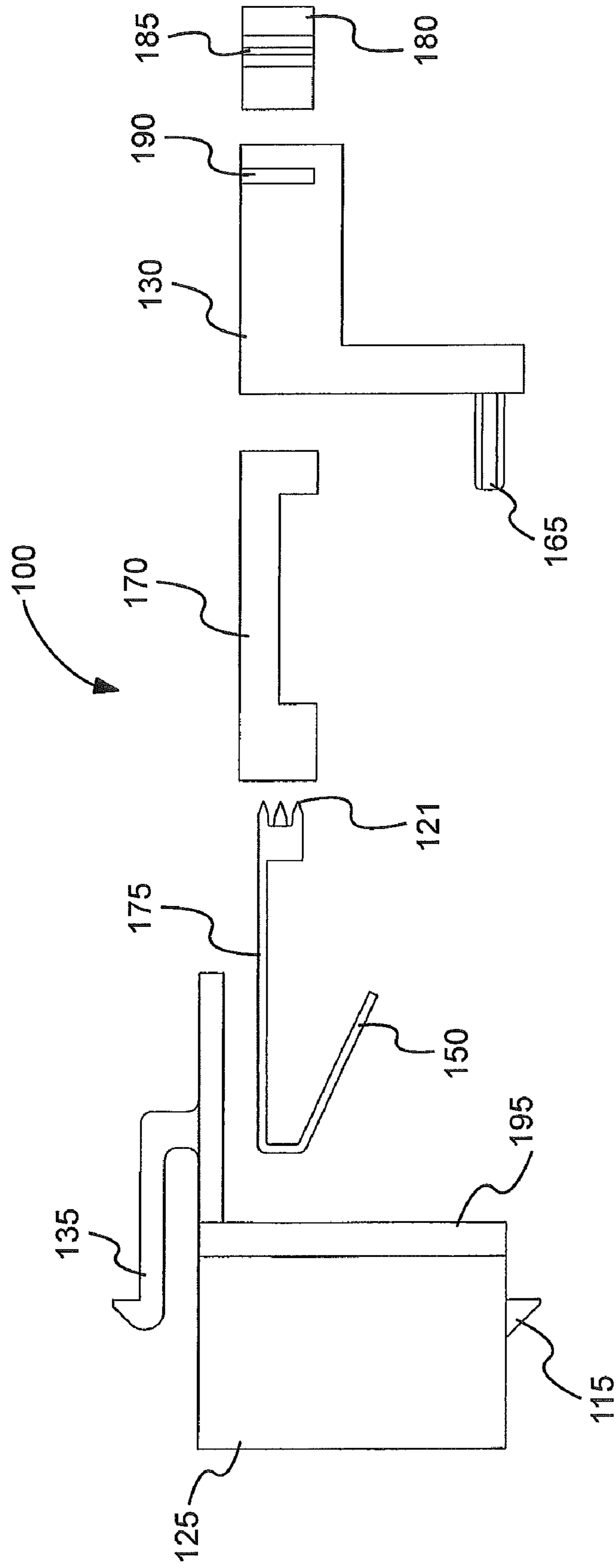

Fig. 2

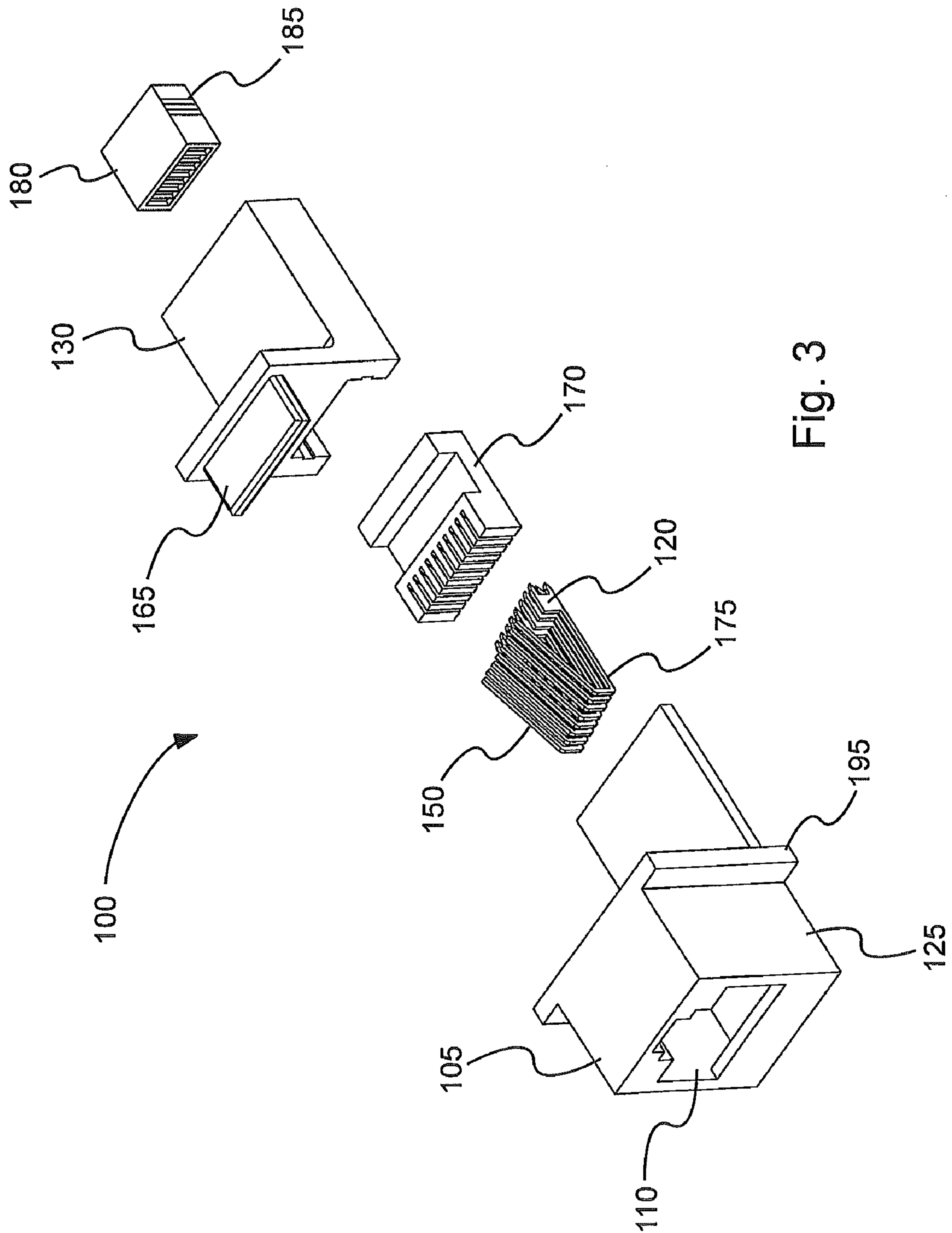

Fig. 3

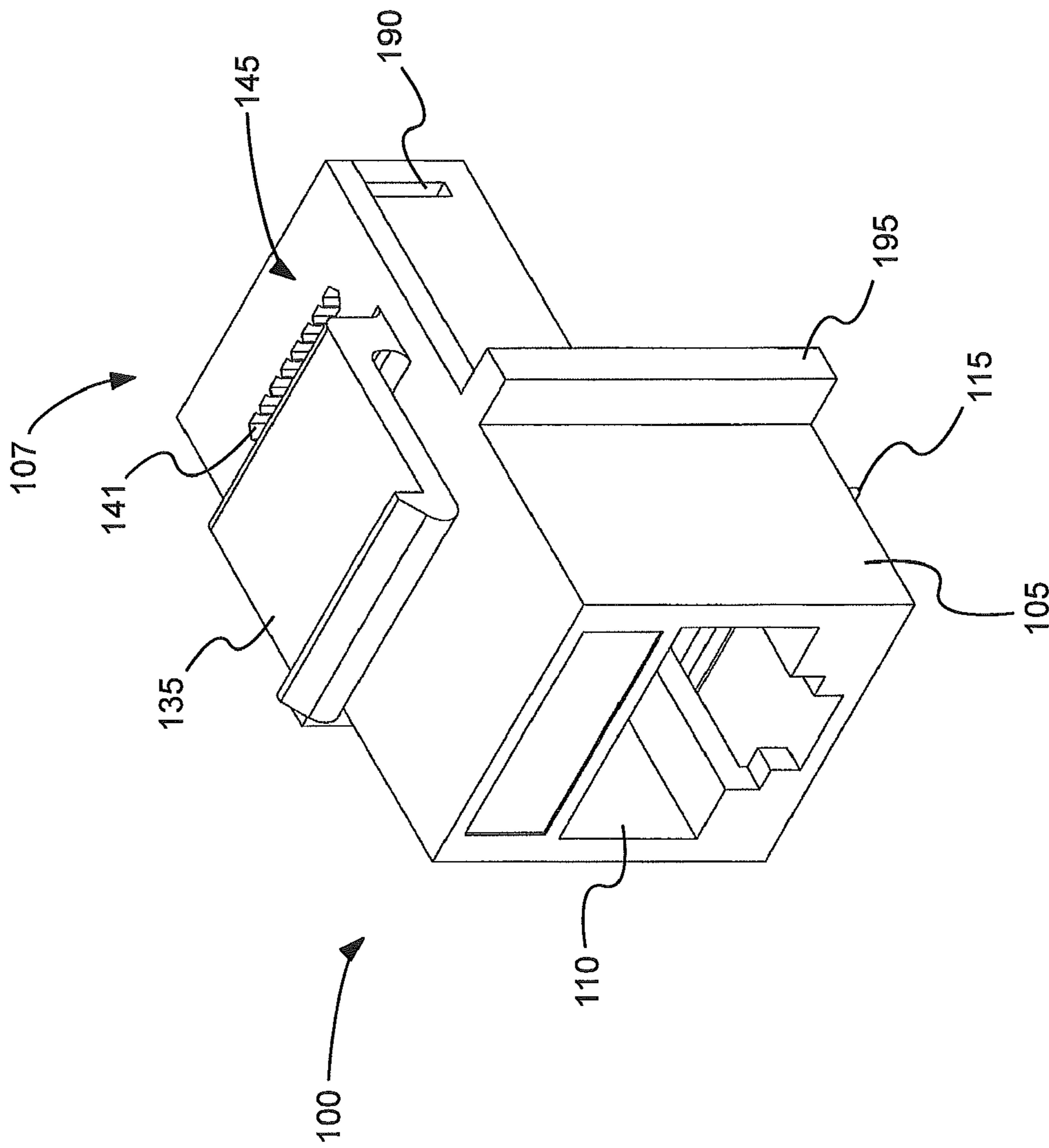

Fig. 4

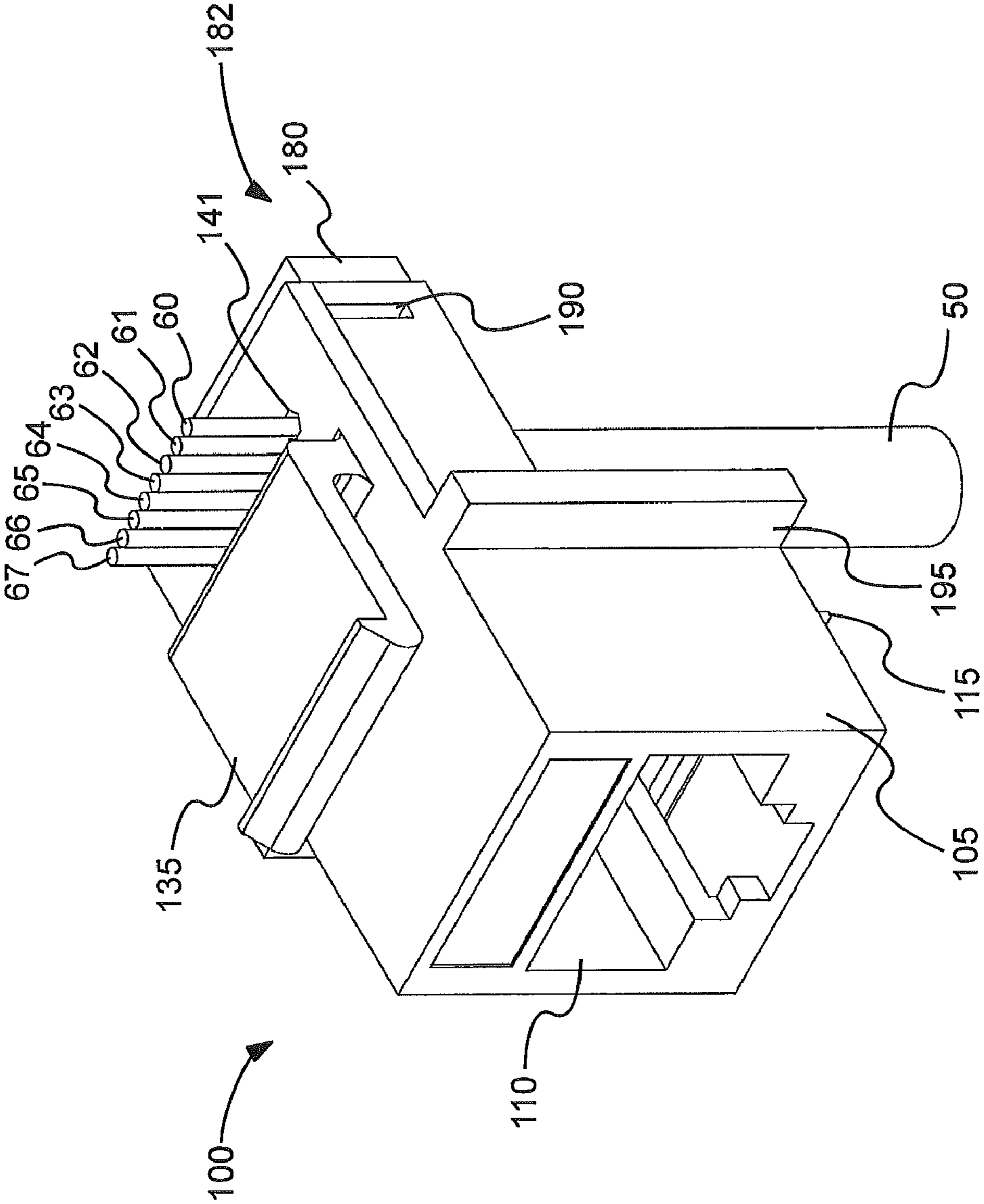

Fig. 5

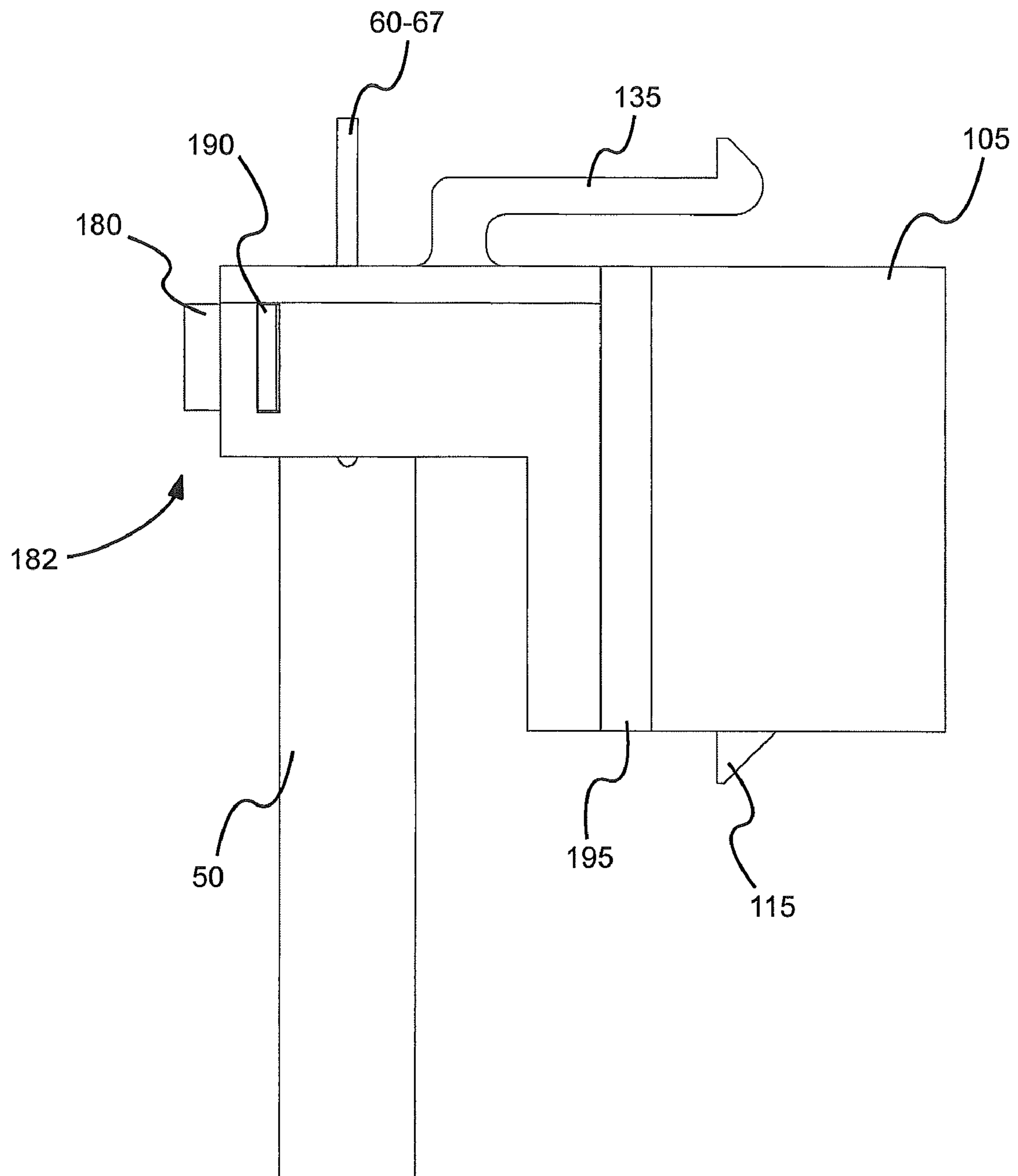

Fig. 6

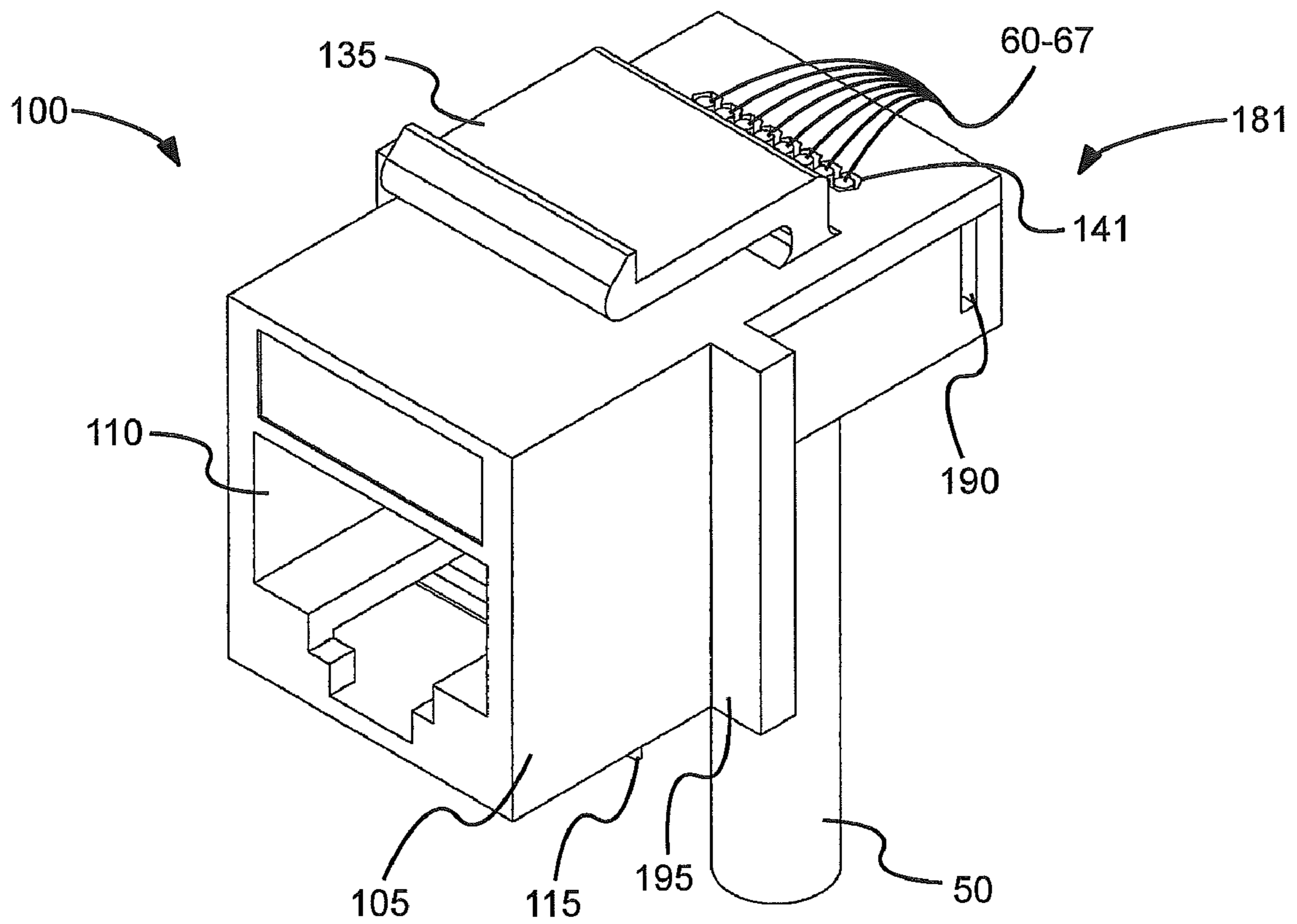

Fig. 7A

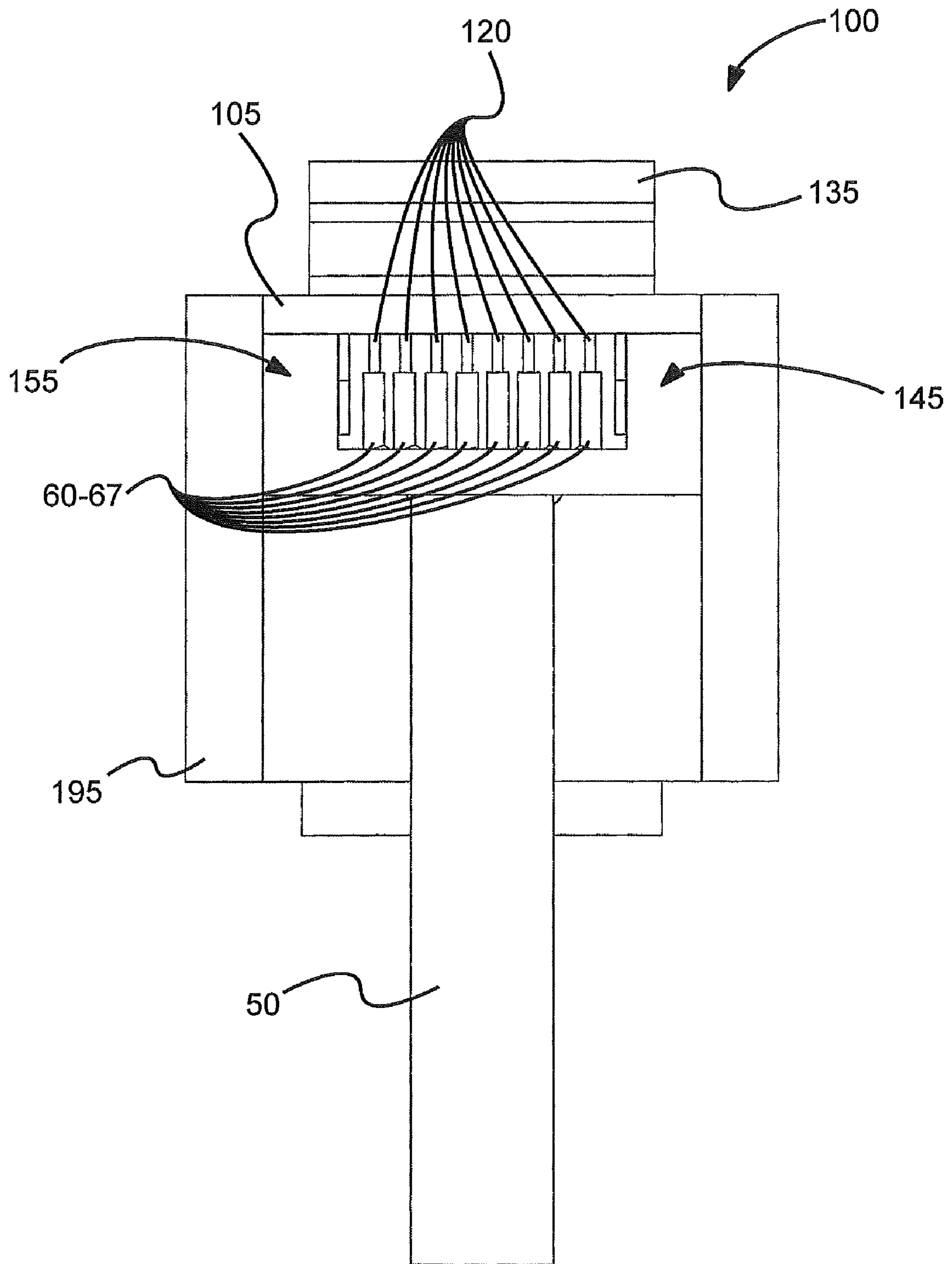

Fig. 7B

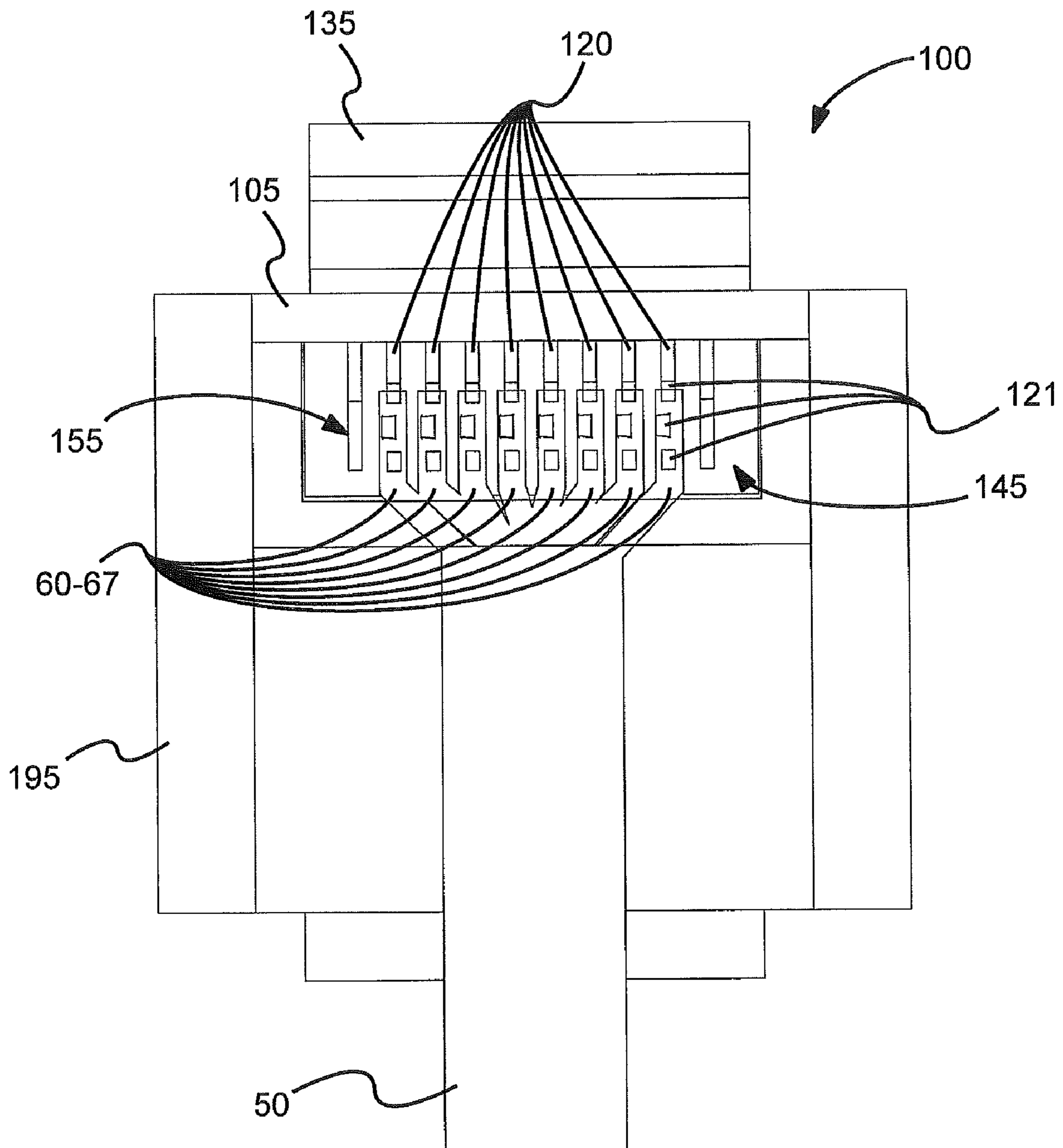

Fig. 7C

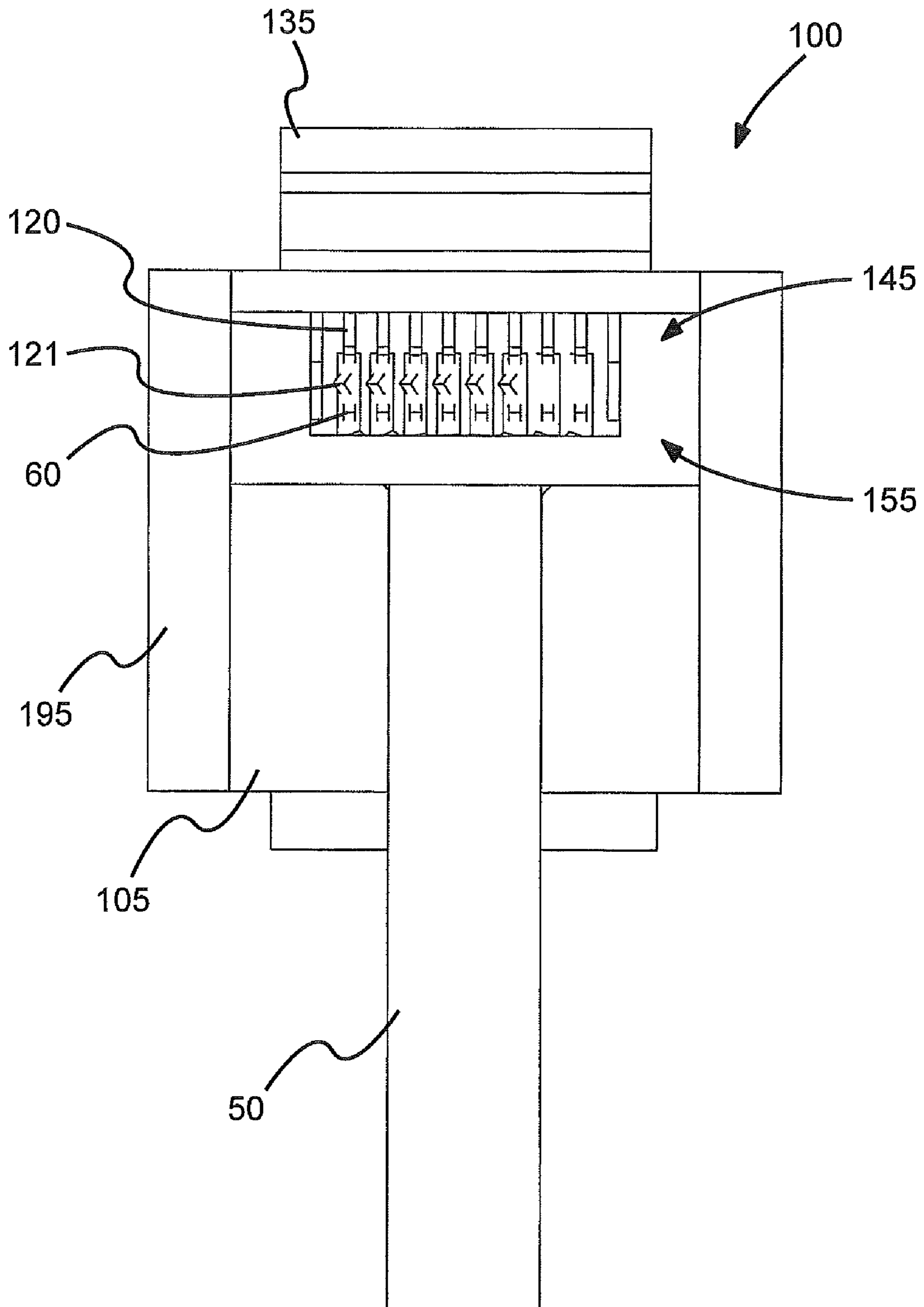

Fig. 7D

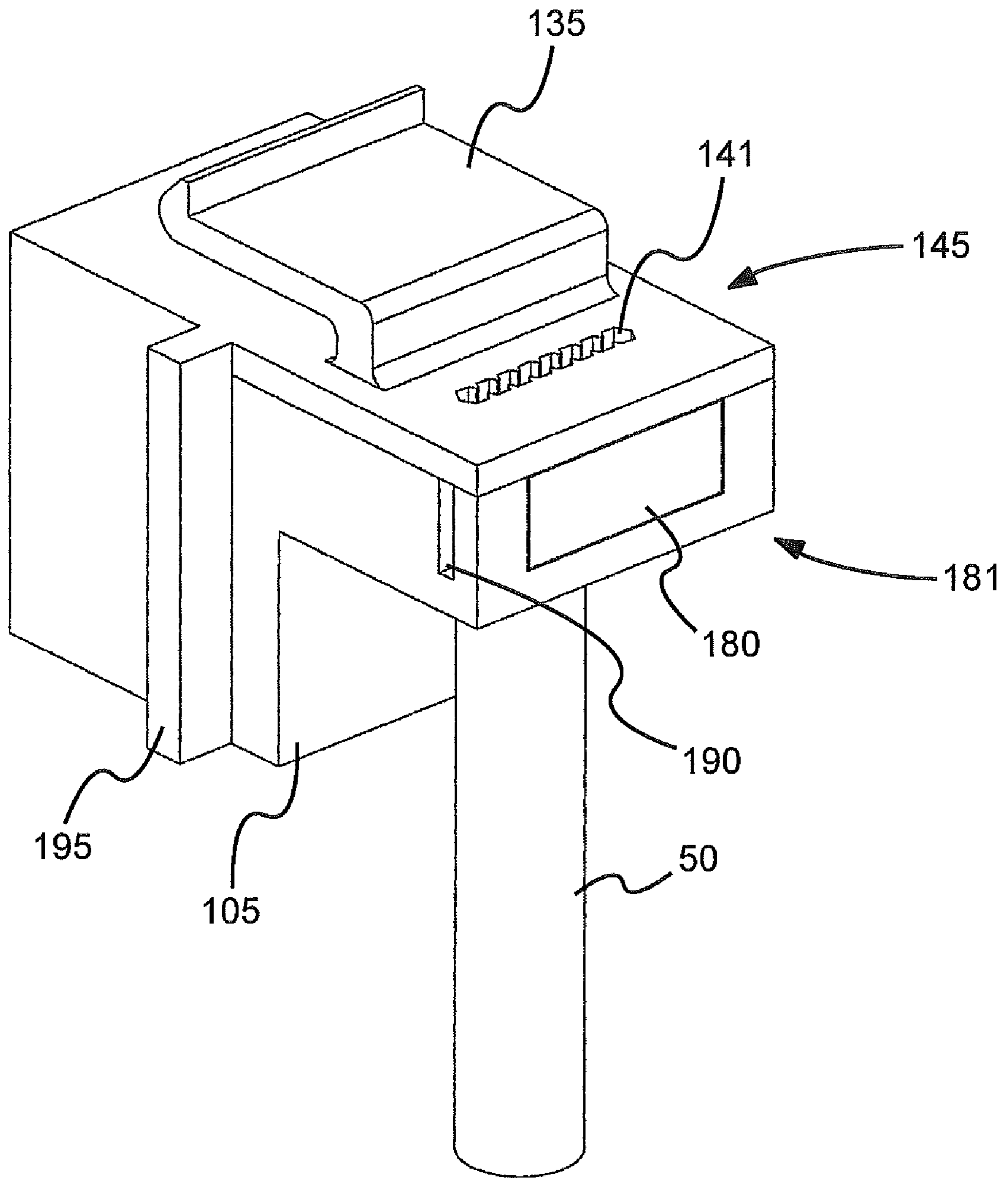

Fig. 8

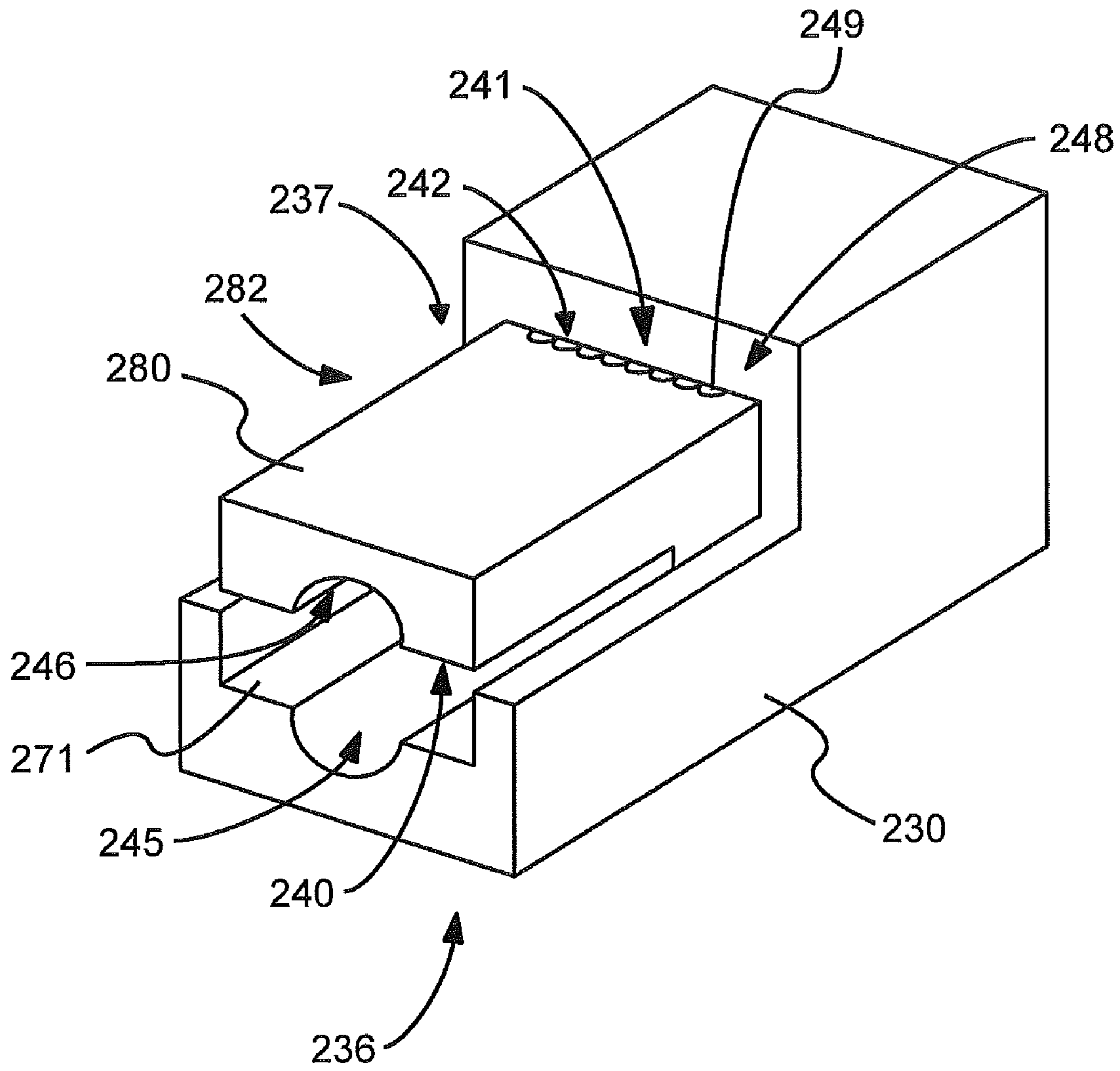

Fig. 9

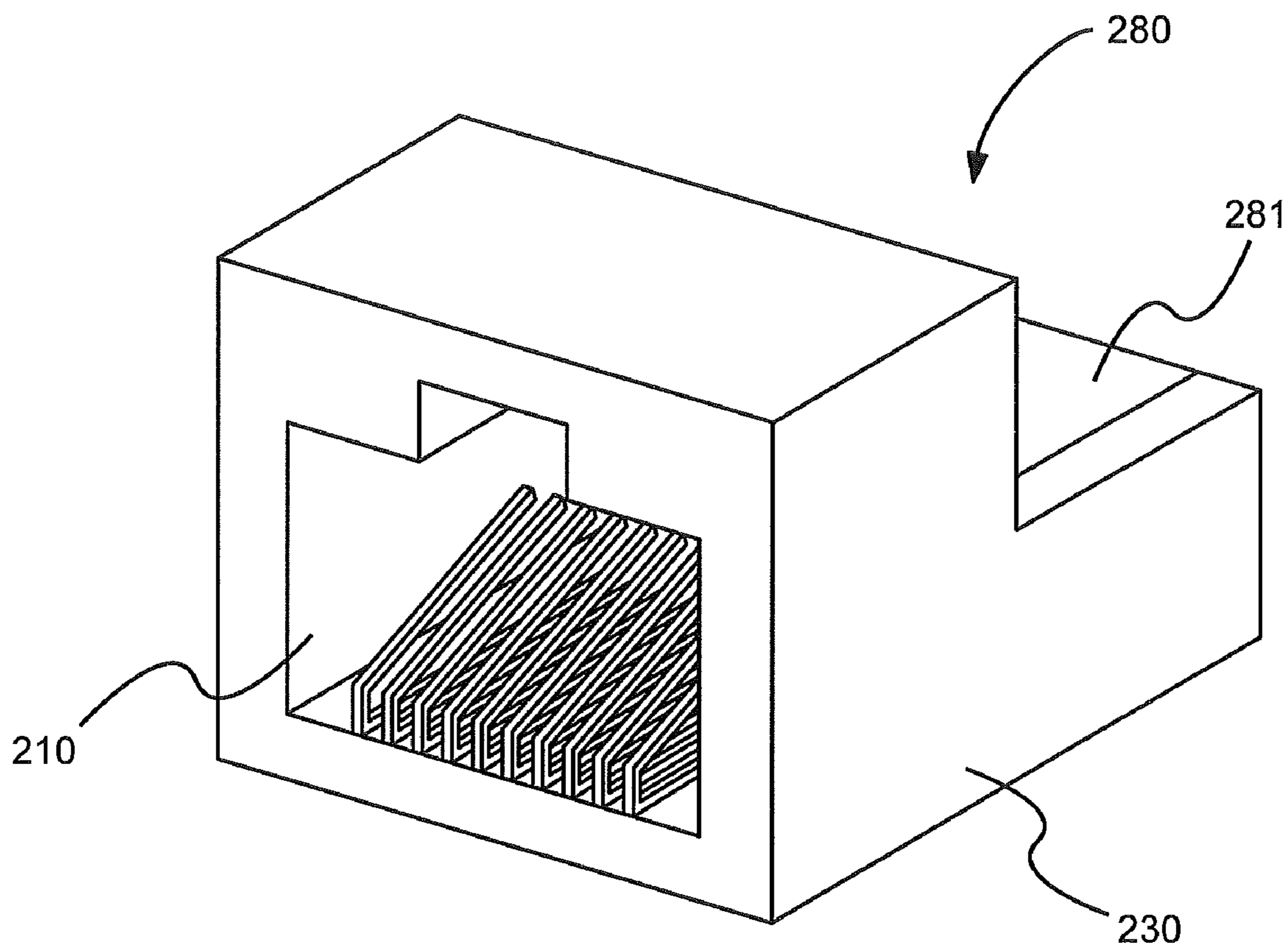

Fig. 10

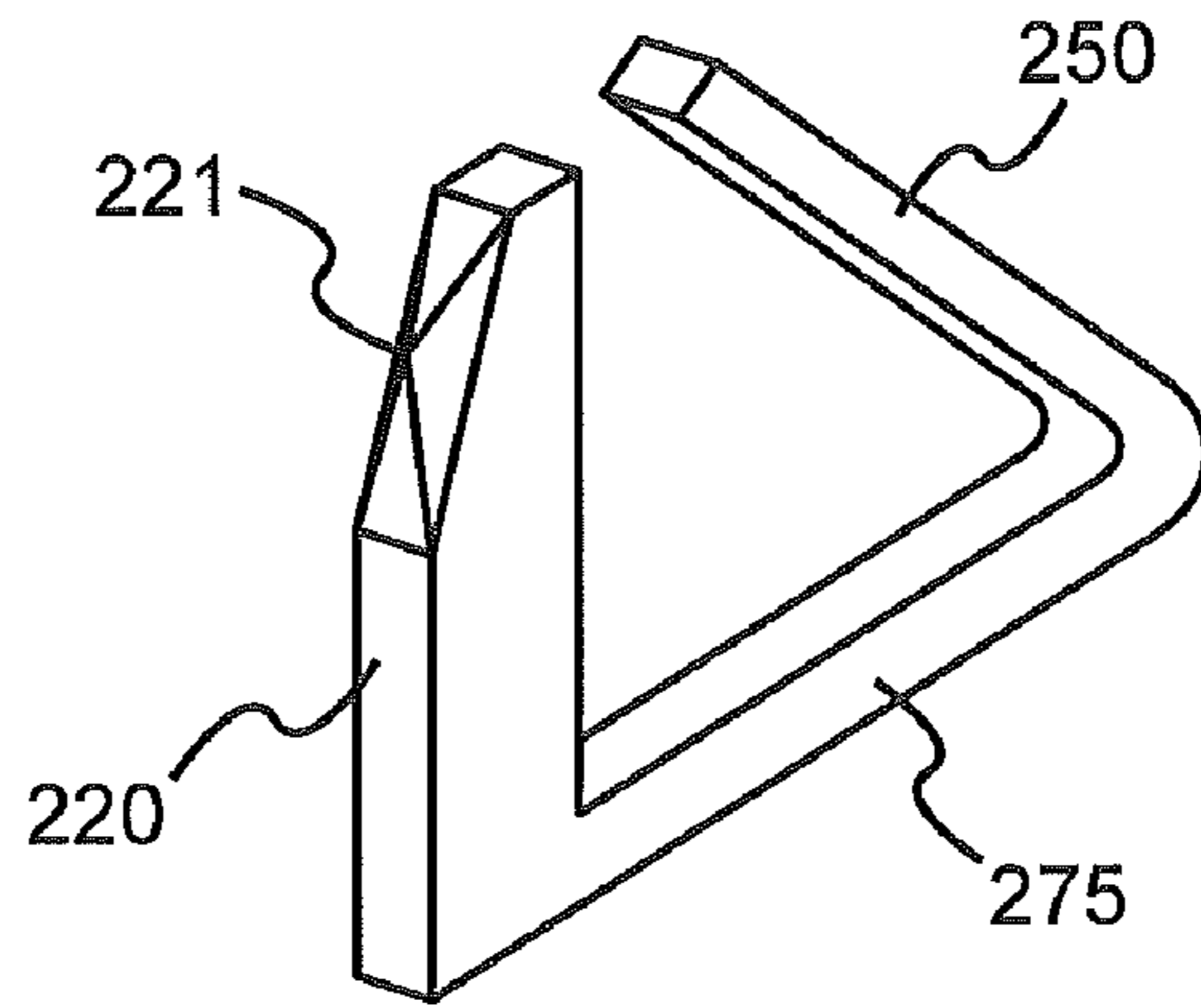

Fig 11

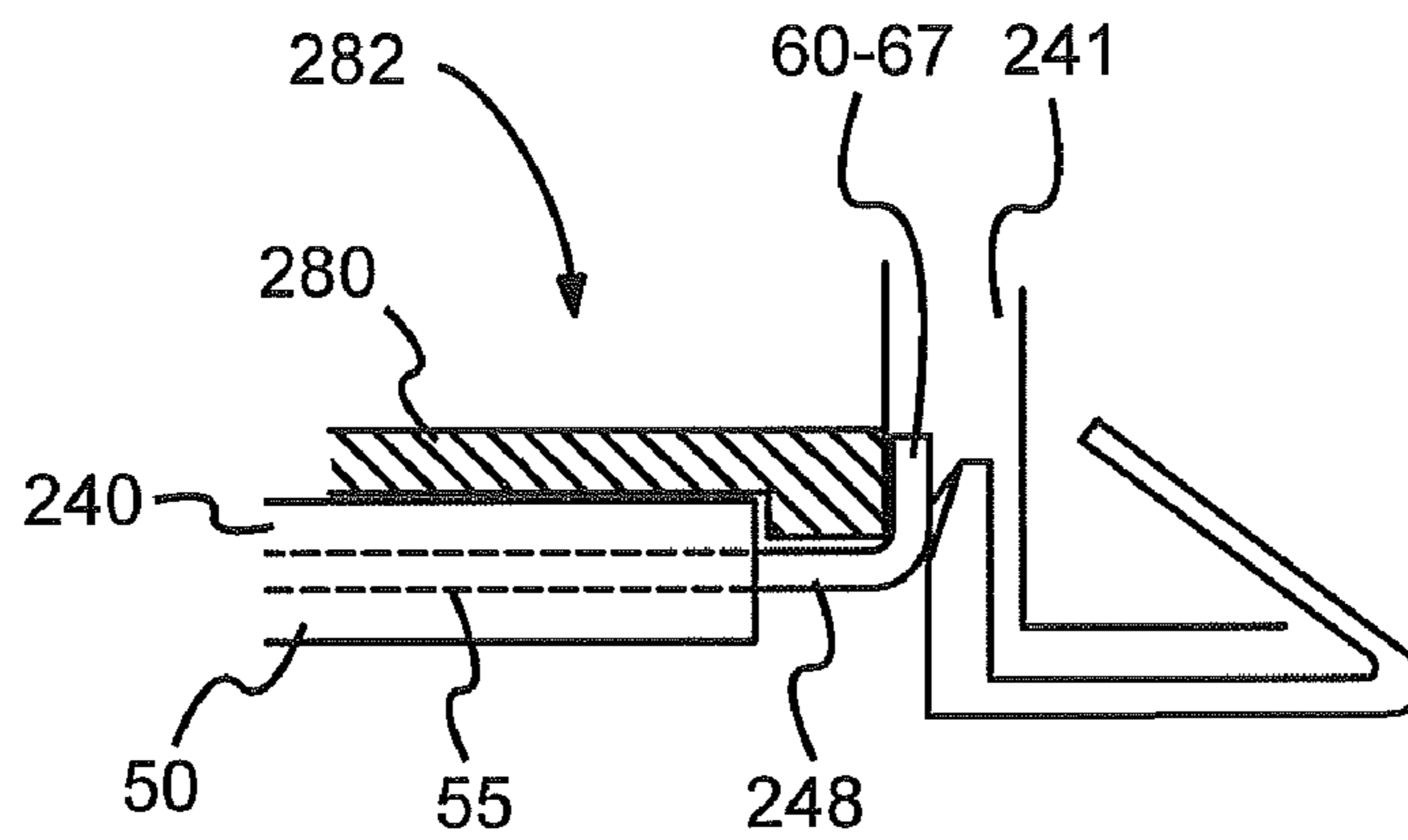

Fig 12

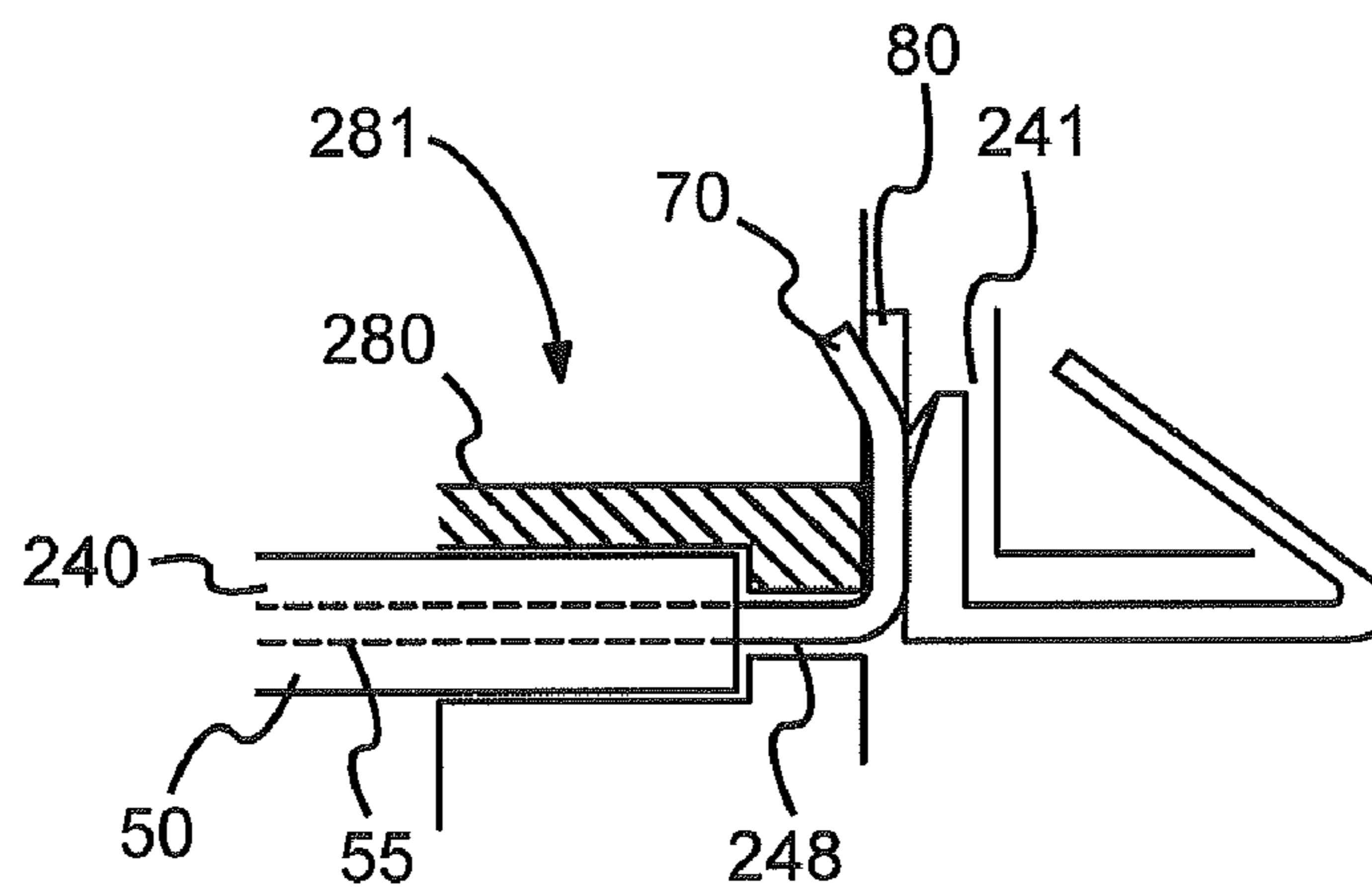

Fig 13

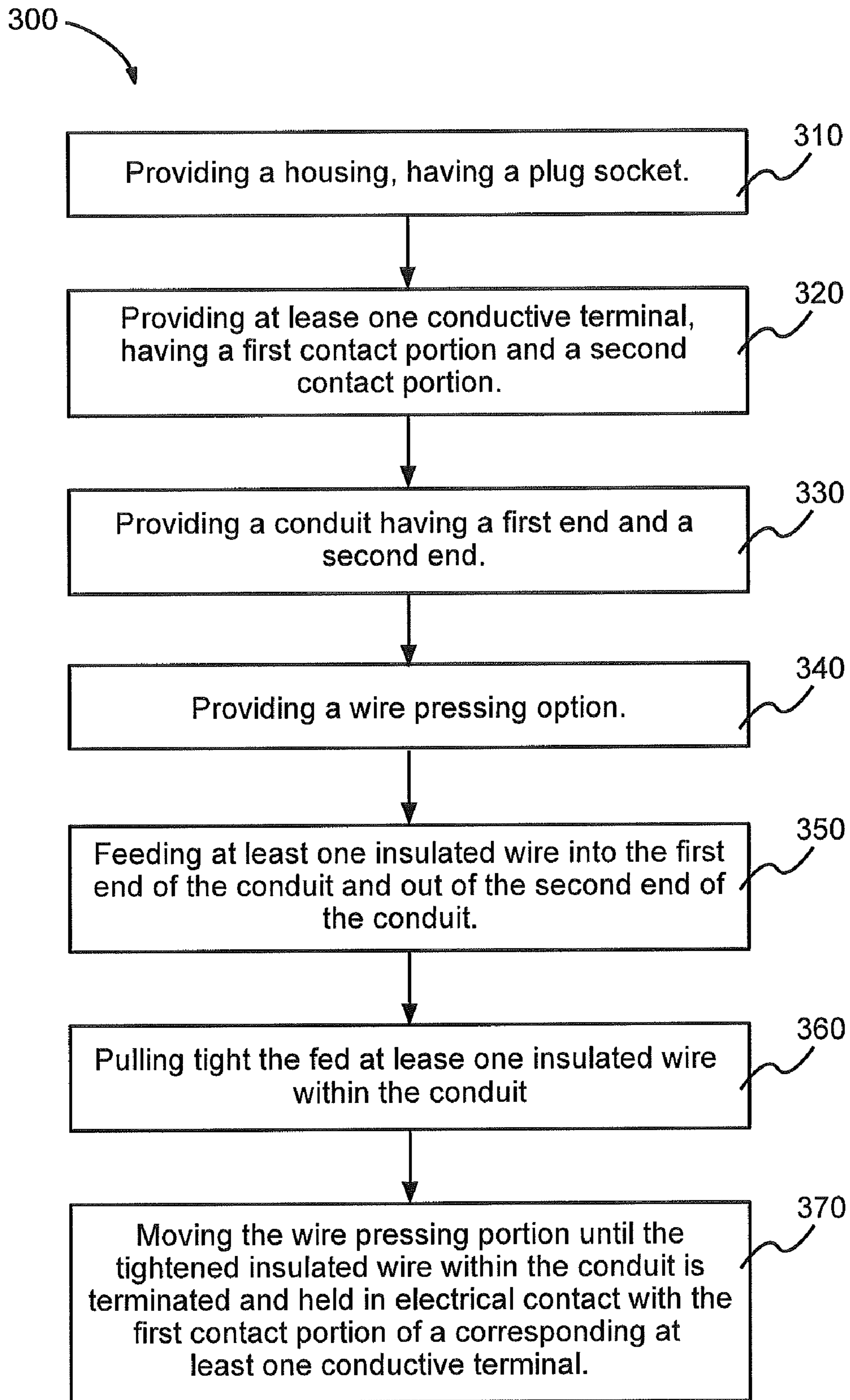

Fig 14

1

PULL THROUGH MODULAR JACK AND METHOD OF USE THEREOF

BACKGROUND OF INVENTION

1. Technical Field

The present invention relates generally to electrical connectors. In particular the invention relates to a pull through modular jack and method of use thereof.

2. Related Art

Modular jacks are widely used in telecommunication systems for facilitating connection of electrical communication components. Ease of installation and consistent termination of internal insulated wires of a communications cable are two important features of a modular jack. Ordinary jacks are designed to orient untwisted wires of a cable for termination with corresponding wire contact terminals according to common communication standards. Standard jack designs involve termination of the untwisted wires with contacts at a terminal location spaced away from where the wires are still bundled and twisted. Wire termination in ordinary jacks is often tedious because each wire must be individually aligned and positioned for termination. Moreover wire termination in common jacks can be faulty because the wires are not precisely located for termination with the jack during cable installation and because wires are often loosely oriented during installation instead of being firmly positioned into a proper termination location. In addition, movement of a cable, once installed, can cause strain that may dislodge the wires from proper termination with ordinary jack terminal contacts. Some known jacks also require use of special tools in order to consistently terminate the wires during installation of the cable to the jack. Accordingly a need exists for an improved modular jack and related method of use.

SUMMARY OF THE INVENTION

A first aspect of the present invention provides an electrical connector jack comprising: an electrical connector jack comprising: a housing, having a plug socket opening; at least one conductive terminal, located within the housing, the conductive terminal having a first contact portion and a second contact portion, wherein the second contact portion extends into the socket; a wire conduit, having a first end opening through the housing and a second end opening through the housing, the wire conduit configured to receive at least one insulated wire, wherein the first contact portion of the at least one conductive terminal extends into the conduit, and wherein the received insulated wire enters through the first end opening and is extendable out of the housing through the second end opening, so that the wire may be pulled tightly into location within the conduit; and a wire pressing portion, having a first non-pressed position and a second pressed position, wherein when the wire pressing portion is in the second pressed position the wire pressing portion acts upon an insulated wire received by the wire conduit and terminates the wire into electrical connection with the first contact portion of a corresponding at least one conductive terminal.

A second aspect of the present invention provides a modular jack comprising: a housing portion, having a plug socket; a first conduit having a first conduit opening, wherein the first conduit opening is configured to receive at least one insulated wire; a second conduit having a second conduit opening, wherein the second conduit opening is configured to permit extension of the at least one insulated wire out of the housing after the at least one insulated wire has been extended through the first conduit opening, so that the at least one insulated wire

2

may be pulled tightly into position within the second conduit; at least one insulation displacement contact located between the first conduit opening and the second conduit opening, wherein the at least one insulation displacement contact is in electrical connection with a corresponding at least one conductive finger; and a pressing portion movably connected to the housing, wherein the pressing portion is configured to move to a pressed position to terminate and hold the at least one insulated wire in electrical connection with a corresponding at least one insulated displacement contact.

A third aspect of the present invention provides an electrical connector jack comprising: a housing, having a plug socket; a cavity within the housing, the cavity in physical communication with a first feed opening for receiving at least one conducting wire and a second feed opening through which a received at least one conducting wire protrudes beyond the exterior of the housing; at least one conductive terminal, having a wire contact portion and a finger portion, wherein the wire contact portion is located within the cavity; and a movable slug having a pressed position, wherein at least one conducting wire, when received, is terminated and held in electrical connection with the wire contact portion of a corresponding at least one conductive terminal when the slug is in the pressed position.

A fourth aspect of the present invention provides an electrical connector jack, comprising: a main body, having a plug socket; at least one conductive terminal within the main body, the conductive terminal having a wire contact portion and a finger portion; a pressing body movably connected to the main body; a first conduit bounded by the pressing body when connected to the main body, the first conduit having an opening for receiving a cable; a second conduit connected to the first conduit, wherein the second conduit is bounded by the connected pressing body and the main body, the second conduit configured to receive at least one insulated wire, and including an end through which a received at least one inner insulated wire protrudes from the housing, wherein the wire contact portion of the at least one conductive terminal is within the second conduit; and wherein the movable pressing body terminates and holds the at least one inner insulated wire in electrical connection with the first contact portion of a corresponding at least one conductive terminal when connected to the main body in a pressed position.

A fifth aspect of the present invention provides a method for assembling an electrical connector jack, the method comprising: providing a housing, having a plug socket; providing at least one conductive terminal within the housing, the conductive terminal having a first contact portion and a second contact portion; providing a conduit having a first end opening and a second end opening, wherein the first contact portion of the at least one conductive terminal is within the conduit; providing a wire pressing portion, the wire pressing portion being movable with respect to the housing; feeding at least one insulated wire into the first end opening of the conduit and out of the second end opening of the conduit, so that the at least one insulated wire extends out of the housing; pulling tight at least one insulated wire within the conduit after it extends out of the housing; and moving the wire pressing portion until the tightened at least one insulated wire within the conduit is terminated and held in electrical contact with the first contact portion of a corresponding at least one conductive terminal.

A sixth aspect of the present invention provides an electrical connector jack comprising: a housing, having a plug socket; at least one conductive terminal within the housing, the conductive terminal having a first contact portion and a second contact portion; a conduit, having a first end opening,

3

for receiving at least one insulated wire and a second end opening, through which a received at least one insulated wire protrudes beyond the housing, wherein the first contact portion of the at least one conductive terminal is within the conduit; and movable means for terminating and securing the received at least one insulated wire in electrical connection with the first contact portion.

BRIEF DESCRIPTION OF THE DRAWINGS

FIG. 1 shows a side view cutaway showing a modular electrical connector jack according to one embodiment of the present invention.

FIG. 2 shows a side view of a modular electrical connector jack prior to assembly according to one embodiment of the present invention.

FIG. 3 shows a perspective view of a modular electrical connector jack prior to assembly according to one embodiment of the present invention.

FIG. 4 shows a perspective view of an assembled modular electrical connector jack according to one embodiment of the present invention.

FIG. 5 shows a perspective view of an assembled modular electrical connector jack after receiving an insulated wire according to one embodiment of the present invention.

FIG. 6 shows a side view of an assembled modular electrical connector jack after receiving an insulated wire according to one embodiment of the present invention.

FIG. 7A shows a perspective view of an assembled modular electrical connector jack after receiving an insulated wire according to one embodiment of the present invention.

FIG. 7B shows a rear view of an assembled modular electrical connector jack after receiving an insulated wire, wherein the pressing portion has been removed to reveal a cavity according to one embodiment of the present invention.

FIG. 7C shows a rear view of an assembled modular electrical connector jack after a received insulated wire begins to engage a wire contact portion according to one embodiment of the present invention.

FIG. 7D shows a rear view of an assembled modular electrical connector jack after a received insulated wire is engaged by a contact point of a wire contact portion according to one embodiment of the present invention.

FIG. 8 shows a rear perspective view of an assembled modular electrical connector jack after receiving and engaging an insulated wire according to one embodiment of the present invention.

FIG. 9 shows a rear perspective view of a modular electrical connector jack according to one embodiment of the present invention.

FIG. 10 shows a perspective view of a modular electrical connector jack according to one embodiment of the present invention.

FIG. 11 shows an exploded perspective view of a conductive terminal according to one embodiment of the present invention.

FIG. 12 shows an exploded side cutaway view of an insulated wire before termination within a modular electrical connector jack according to one embodiment of the present invention.

FIG. 13 shows an exploded side cutaway view of an insulated wire after termination within a modular electrical connector jack according to one embodiment of the present invention.

4

FIG. 14 shows a method for assembling an electrical connector according to one embodiment of the present invention.

DETAILED DESCRIPTION OF THE INVENTION

Although certain embodiments of the present invention will be shown and described in detail, it should be understood that various changes and modifications may be made without departing from the scope of the appended claims. The scope of the present invention will in no way be limited to the number of constituting components, the materials thereof, the shapes thereof, the relative arrangement thereof, etc., and are disclosed simply as an example of an embodiment. The features and advantages of the present invention are illustrated in detail in the accompanying drawings, wherein like reference numerals refer to like elements throughout the drawings.

As a preface to the detailed description, it should be noted that, as used in this specification and the appended claims, the singular forms "a," "an" and "the" include plural referents, unless the context clearly dictates otherwise.

Referring to FIGS. 1-4, an electrical connector 100 is shown, having a housing portion 105. The electrical connector 100 may be a modular jack configured according to typical registered jack communication standards. Housing portion 105 may comprise at least two separate pieces, for example a first housing portion 125 and a second housing portion 130, attachably connected to form main body 105. A multi-piece housing is clearly shown in FIGS. 2-3. Furthermore, one housing portion 125, 130 may include a mating connector 165 in order to aid in the assembly of the housing portion 105. Mating connector 165 may be designed to be inserted into the hollow of a corresponding housing portion. Housing portion 105 may be a plastic material, or any other material that would help insulate electrical wiring from the outside environment, such as rubber or any other polymer.

Housing portion 105 may further comprise a resilient latch tab 135. Resilient latch tab 135 may cooperate with fixed latch member 115 to releasably retain the electrical connector 100 in assembly with an associated apertured wall plate (not shown). Resilient latch tab 135 may be located on the top face of main body 105, and fixed latch member 115 may be on the bottom face of main body 105. Alternately, resilient latch tab 135 and fixed latch member 115 may be located on any opposing faces. It should be understood by one of ordinary skill that latching combination 135, 115 is not limited to that as shown in FIGS. 1-8, but may also be a fastener, a catch, a clasp, a clench, a grip, a hold, a lock, a press, a snap and a vice so long as electrical connector 100 is releasably retained in assembly with an associated wall plate.

Electrical connector 100 includes a plug socket 110 opening up into the housing 105. The socket 110 may be located on the front face of main body 105, and may be configured to accept a cable plug, including, but not limited to any type of registered jack (RJ) connector. For example, socket 110 may be configured to accept the plug connector of a shielded twisted pair (STP) cable, an unshielded twisted pair (UTP) cable, a screened shielded twisted pair (S/STP) cable, a fully shielded twisted pair (FTP) cable, or any variant thereof. Electrical connector 100 may therefore be any form of modular jack.

The electrical connector 100 includes at least one conductive terminal 175. Conductive terminal 175 may be housed within the housing portion 105. A further conductive terminal housing 170 may also be provided to further house and protect conductive terminal 175. Conductive terminal 175 may include a first wire contact portion 120 having one or more wire contact points 121, and a second wire contact portion

150. In operation, the first contact portion 120 and the second contact portion 150 may be located within conductive terminal housing 170. However, the first contact portion 120 and the second contact portion 150 may also be operably located outside of conductive terminal housing 170. Second contact portion 150 may be a conductive finger, configured to be electrically connected to a modular plug (not shown), whereby the conductive finger 150 may be located within socket 110.

Electrical connector 100 may further include a cavity 155. Cavity 155 may operate with a conduit 145 having first end opening 140 through the housing 105 and configured to receive at least one insulated wire 60, 61, 62, 63, 64, 65, 66, 67 (see FIG. 5-8) fed through into the conduit 145. The cavity 155 may operate with a second end 141 of the conduit 145, wherein the second end opening extends through the housing 105. The cavity 155 may be in physical communication with the first end opening 140 and the second end opening 141. The at least one received insulated wire 60-67 may be received into the conduit 145 and may pass through the cavity 155, and may be extended through the second opening 141 and out of the housing 105 (see, for example, FIGS. 5-6). When the insulated wire 60-67 extends through the second opening 141, the wire 60-67 may be pulled tight through the conduit 145 and conduit cavity 155. First feed opening 140 may be located on the first bottom face 106 of the housing 105, and the second feed opening 141 may be located on the second top face 107 of the housing 105. Alternately, wire feed conduit openings 140, 141 could be located on the left and right sides of housing 105.

First and second feed openings 140, 141 of a conduit 145 may comprise a plurality of interconnected channels, each channel configured to accept a corresponding individual insulated wire 60-67. Alternately, first and second conduit openings 140, 141 may extend with a number of individual through hole conduits 145. It will be apparent to those skilled in the art that wire feed conduits 145 may take various forms which allow an insulated wire 60-67 to be pulled through housing 105 to extend out of the housing 105. Insulated wire 60-67 may be the internal twisted wires of a STP, UTP, S/STP, or FTP cable 50, as described above. Although not limited to this position, cavity 155 may be contained within a thinner portion of the main body 105 of jack 100.

With further reference to FIGS. 1-4 and additional reference to FIGS. 5-8, insulated wires 60-67 may be pulled through the housing and tightened so that the outer insulation of twisted wire cable 50 abuts first conduit opening 140 of housing portion 105, and so that the ends of the wires 60-67 extend out of the housing 105 through the second conduit opening 141. Thus, the outer insulation of twisted wire cable 50 protects the internal insulated wires 60-67 close to where the internal insulated wires 60-67 are inserted into the housing through first feed opening 140. Furthermore, the insulated wires 60-67, as protruding through second opening 141, may be cut flush (as in FIG. 7) with the top of main body 105.

Moreover, as depicted in FIGS. 7B-7D, which depict a rear view of the connector having the plug 180 removed to readily view the cavity 155, the insulated wires 60-67 may be inserted through the first feed openings 140 and into association with cavity 155. The first contact portion 120 may include one or more contact points 121 that may extend within at least a portion of conduit cavity 155. The first wire contact portion 120 may be an insulated displacement contact (IDC) for connecting at least one insulated wire 60-67 to conductive terminal 175. The contact points 121 of the IDC 120 may have sharpness sufficient to pierce or slice the insulation of the wires 60-67, thereby terminating insulated wires 60-67.

There may be a plurality of IDCs 120 each corresponding to at least one insulated wire 60-67. The placement of the cavity 155 and conduit 145 of the electrical connector 100 allows the contact between IDC(s) 120 and insulated wire(s) 60-67 to be very close to point at which the insulated wires 60-67 are still twisted as commonly included in a single cable 50.

The electrical connector 100 includes a pressing portion 180, such as a slug, plug member, or other insertable component, configured to be inserted into a pressing portion cavity 160. The pressing portion 180 may have a generally rectangular shape and may be made of a plastic material and may also be made of any other suitable non-conductive material. Pressing portion 180 may be inserted into pressing portion cavity 160 on the back face of the main housing body 105. The pressing portion 180 includes a first non-pressed position 182, wherein the pressing portion does not fill a substantial portion of cavity 160. The pressing portion 180 also includes a second pressed position 181, wherein the portion 180 is significantly inserted into the cavity 160. In addition, the pressing portion 180 may include a pressing portion latch tab 185 which may catch into a pressing portion locking hollow 190, in order to releasably retain pressing portion 180 in a pressed position. Thus, pressing portion 180 may be movably connected to housing portion 105. The movement of the pressing portion 180, between the first non-pressed position 182 and the second pressed position 181 may be horizontal with respect to the jack 100 and in a direction substantially parallel to the extension of socket 110 into housing 105.

When insulated wires 60-67 are pulled through the housing and tightened (as in FIGS. 5-6), so that the outer insulation of twisted cable 50 abuts first feed opening 140 through housing 110, pressing portion 180 may be inserted into pressing portion cavity 160, and pressed and held in the pressed position 181 (as in FIGS. 7A-8) by the cooperation of pressing portion latch tab 185 and pressing portion locking hollow 190. Pressing portion 180 may apply pressure to insulated wires 60-67, pushing them in the direction of IDCs 120, whereby the IDCs 120 terminate the insulated wires 60-67. FIGS. 7B-7D depict a rear view of the jack 100 with the pressing portion 180 removed to reveal the operable engagement of the wires 60-67 by the contact points 121 of the IDC's 120 within cavity 155, as the pressing portion 180 is compressed against the wires 60-67. Insulated wires 60-67 may be held in electrical connection with conductive terminal 175 by the insertion of pressing portion 180 into pressing portion cavity 160, so that the pressing portion 180 is secured into a compressed position 181, wherein the wires 60-67 are engaged by the contact points 121 of IDC's 120. Once in a compressed position 181, wherein the wires 60-67 are engaged by the first contact portion IDC 120, the cavity 155 may closely resemble a circumferential chamber for insulated wires 60-67.

It will be apparent to those skilled in the art that the means for terminating and securing the received insulated wire 60-67 in electrical connection with the first contact portion may take various forms. For example, terminating means may include a pressing portion 180, operable with a housing body 105 as described hereinabove, or an attachable pressing body 280 operable with a main housing body 230, as described herein below in relation to FIGS. 9-13. Alternately, embodiments of the electrical connector 100 may not include a separate pressing portion 180. Instead, terminating means may comprise the entire housing 105 sliding forward, compressing insulated wire 60-67 against insulation displacement contact 120 when the wires have been pulled tight through openings 140, 141 of the housing 105.

Once terminated, cable 50 may remain in a vertical position, 90 degrees to jack 100, as shown in FIGS. 5-8. However,

a cap or other cover element (not shown) may be supplied to physically attach to the jack **100** to help position the cable in a bent, "parallel," state, wherein the cable is horizontal to the jack **100** when it engages the jack **100**, so that the cable **50** extends in parallel with the extension of socket **110** into body **105**. Such a cover component may also provide an additional means of strain relief to the jacket of the cable.

FIGS. 9-10 illustrate another embodiment of the invention. An electrical connector jack **200** is shown having a main body **230**. Similar to the housing portion **105** of the previous connector embodiment **100**, main body **230** may comprise multiple pieces, attachably connected, in a manner similar to that described with respect to the previous embodiment **100** hereinabove. However, the main body **230** may also be formed of a single component. Main body **230** further comprises a socket **210** for receiving a plug (not shown). Main body **230** also may comprise a cooperating resilient latch tab **235** and a fixed latch member **215** to releasably retain electrical connector jack **200** in operable assembly with an apertured wall plate, as similarly described in relation to the previous embodiment **100** hereinabove.

Electrical connector jack **200** may include a pressing body **280**, such as a slug, plug member, or other insertable component, configured to be pressed into cooperation with a portion of the main body **230**, to press the wires **60-67** of a cable **50** into contact with IDC's **220** (as depicted in FIGS. 11-13). Pressing body **280** may be generally rectangular in shape and may be movably attached to main body **230**, on the second top face of main body **230**. Main body **230** may include a first channel **245** and pressing body **280** may also contain a second channel **246**. As depicted in FIG. 9, the wire pressing body portion **280** is in a first non-pressed position **282**. The wire pressing body portion **280** may be moved in a direction perpendicular to the general axis of extension of the socket **210** of the connector **200**. When pressing body **280** is moved to a pressed position **281**, attachably connected to main body **230**, channel **245** and channel **246** may combine to form a first conduit **240**. Thus, when the pressing body **280** is movably connected to main body **230** in a pressed position **281**, first conduit **240** is bounded by the channel **246** on the bottom of the pressing body **280** and channel **245** on the top face of the main body **230**. Conduit **240** may have a circular, oval, square, or rectangular cross sectional shape, or any other shape that allows first conduit **240** to receive a STP, UTP, S/STP, FTP cable, or any variant thereof. The first conduit **240** may extend from a first back face of the main housing body **230** located opposite the socket **210** opening into the main body **230**. Thus, cable **50** may be inserted conduit **240** in a direction parallel to the insertion of a typical plug into the socket **210** of the electrical connector **200**.

The electrical connector **200** may also contain at least one second conduit **241** also bounded by main body **230** and pressing body **280**. The second conduit **241** may run perpendicular to the first conduit **240**. The second conduit **241** receives at least one conducting wire **60-67** extending from a cable **50** inserted into the first conduit **240**. The wire **60-67** may be bent up and around the end of the pressing body **280** so that the cable resides in and extends through the second channel portion **249** and ultimately protrudes through a second opening **248** of the second conduit **241** on a second face **237** of the main body **230**, when the pressing body **280** is pressed into attachable contact with the main body **230**. Second conduit **241** may further comprise a plurality of interconnected channels, each configured to accept a corresponding individual conducting wire **60-67**. Alternately, second conduit **241** may comprise at least one non-interconnected individual channel **242**. In this configuration, the bounding wall

of pressing body **280** may comprise grooves forming individual channel(s) **242**, or the bounding wall of main body **230** may also comprise grooves forming channel(s) **242**. Alternately, both the bounding wall of pressing body **280** and main body **230** may comprise the grooves which together form individual channels.

Second conduit **241** may be connected to first conduit **240** and may also be on a perpendicular plane to first conduit **240**. Therefore, the second conduit opening **248** through which the conducting wire **60-67** protrudes may be located on the top face of main body **230**. First conduit **240** and second conduit **241** in combination may be considered a single conduit for accepting insulated wire **60-67**, having a first end **247** and a second end **248**.

Referring to FIG. 11, a conductive terminal **275** is shown, having a first IDC portion **220** and a second finger portion **250**. Electrical connector **200** may comprise a plurality of conductive terminals **275**. The finger portion **250** may become electrically connected to the plug in a manner similar to the conductive finger **150** of electrical connector **100** as described hereinabove. The IDC portion **220** includes a pointed, sharpened, or otherwise blade-like wire contact portion **221**, wherein the contact portion **221** is sharp enough to pierce or slice the insulation of conducting wire **60-67**. Electrical connector **200** may be configured so that the IDC wire contact portion **221** of each conductive terminal **275** is located within second conduit **241**. When pressing body **280** is attached to main body **230**, an insulated conducting wire **60-67** may be terminated with the wire contact portion **221** of the IDC **220**, as described herein below.

FIG. 12 shows a side cutaway view of pressing body **280** prior to being attached to main body **230**. As shown in FIG. 12, the pressing body is not located in a pressed position **281** and the insulated conducting wire **60-67** is not terminated or otherwise electrically coupled to wire contact portion **220**. A cable **50** having an outer insulation **55** and one or more internal insulated wires **60-67** is shown following insertion within first conduit **240**. An end portion of the insulation **55** of the cable **50** is stripped away and the internal insulated wires **60-67** of the cable **50** are pulled tight around and through the second conduit **241**.

FIG. 13 shows a side cutaway view of pressing body **280** after termination of insulated wires **60-67** with the sharp contact portion **221** of the IDC **220** of the conductive terminal **275**. By positioning the pressing body **280** in a pressed position **281**, the wires **60-67** may be forced into contact with the sharp portion **221** of IDC **220**. As shown, an inner conductor **80** of wire **60** comes into electrical connection with IDC **220** after the insulation **70** of the wire **60** has been cut sliced, pierced, or otherwise displaced by the IDC portion **220**, and is held in electrical connection by attached pressing body **280**, when in the pressed position **281**. The pressing action of the pressing body **280** may allow the wire **60** to move downward, or parallel to the orientation of the IDC **220**. Thus the IDC **220** may slice the outer insulation **70** of the wire **60** and make good physical and electrical contact with the inner conductor **80** of the wire **60**.

Referring to FIG. 14, a method for assembling an electrical connector **300** is shown. Method **300** comprises the step **310** of providing a housing containing a socket which is configured to receive a plug. The housing and socket may be similar to those described hereinabove as housing **105**, **230**, and socket **110**, **210**, as shown in FIGS. 1-13. The plug, although not shown, may be any standard plug operable with internal twisted wires of a STP, UTP, S/STP, or FTP cable, such as cable **50**. For instance, the plug may be a typical registered jack plug. Further methodology includes the step **320** of

providing at least one conductive terminal within the housing, the conductive terminal having a first and second contact portion, the second contact portion configured to be electrically connected to the plug. The conductive terminal and first and second contact portions may be similar to those described hereinabove as conductive terminal **175**, **275**, first contact portion **120**, **220** and second contact portion **150**, **250**, as shown in FIGS. **1-13**. Additionally, the electrical connector assembly method includes a step **330** of providing a conduit having a first end and a second end, the first contact portion of the conductive terminal being in the conduit. The conduit, first end openings, and second end openings are described hereinabove as conduit **145**, **240**, **241**, first end opening **140** and **247**, and second end **141**, and **248**. If the conduits **240** and **241** comprise one interconnected conduit, then that conduit would have a first end opening **247** and a second end opening **248**.

The method of assembling an electrical connector **300** further comprises the step **340** of providing a movable wire pressing portion. The wire pressing portion is described hereinabove as pressing portion **180**, **280**, as shown in FIGS. **1-13**. The movement of the wire pressing portion helps to terminate wires **60-67** to conductive elements within the housing **105**, **230**. Moreover, the electrical connector assembly method **300** includes the step **350** of feeding at least one insulated wire **60-67** into the first end **140**, **247** of the conduit **145**, **240**, **241** and out of the second end **141**, **248** of the conduit **145**, **240**, **241**. The wires **60-67** may be fed into channels, such as through openings **140**, **141**, **247**. Then an additional assembly method step **360** of pulling tight the fed insulated wire within the conduit **145**, **241** may be performed. This step may also include pulling the wire tight through a cavity **155**. An electrical connector may further be assembled by performing a step **370** of moving the wire pressing portion until the tightened insulated wire **60-67** within the conduit **145**, **241** is terminated and held in electrical contact with the first contact portion **120**, **220** of a corresponding conductive terminal **175**, **275**.

In addition to the methodology described above, the electrical connector assembly method **300** may further comprise a step of untwisting twisted insulated wires **60-67** before feeding the wires into the conduit. This step may include orienting the twisted pairs into proper position so that they may be fed into corresponding channels of the conduit of step **350**. The proper position of the wires may correspond to the type of electrical connector being assembled. For instance, assembly of a registered jack may include untwisting the wires and positioning them in the conduit for contact with conductive terminals that corresponding to a specific registered jack configuration, such as an RJ-45 configuration. Once the wires are terminated through movement of the pressing body, an additional method step may include clipping off the wires at the second end of the conduit so that they do not protrude from the housing (see, for example, FIGS. **5-8**).

In one embodiment, method **300** may further comprise positioning an insulated wire **60-67** so that the wire is perpendicularly aligned with the first contact portion. In this embodiment, such as for example connector **100**, the assembly method **300** may involve moving the wire pressing portion sideways terminating the insulated wire with the first contact portion of the conductive terminal. Alternately, method **300** may further comprise an positioning an insulated wire **60-67** so that it is aligned parallel with the first contact portion, such as may be operable with a connector **200**. As such, the assembly method **300** may involve moving the wire pressing portion causing the wire to move downward, parallel

to the orientation of the first contact portion. The first contact portion may slice the outer insulation of the wire and make physical and electrical connection with the insulated wire.

While this invention has been described in conjunction with the specific embodiments outlined above, it is evident that many alternatives, modifications and variations will be apparent to those skilled in the art. Accordingly, the preferred embodiments of the invention as set forth above are intended to be illustrative, not limiting. Various changes may be made without departing from the spirit and scope of the invention as defined in the following claims. The claims provide the scope of the coverage of the invention and should not be limited to the specific examples provided herein.

I claim:

1. An electrical connector jack comprising:
 - a housing, having a plug socket opening;
 - at least one conductive terminal, located within the housing, the conductive terminal having a first contact portion and a second contact portion, wherein the second contact portion extends into the plug socket opening;
 - a wire conduit through the housing, extending from a first end opening in the housing to a second end opening in the housing, the wire conduit configured to receive at least one insulated wire, wherein the first contact portion of the at least one conductive terminal extends into the conduit, and wherein the received insulated wire enters through the first end opening and is extendable out of the housing through the second end opening, so that the wire may be pulled tightly into location within the conduit; and
 - a wire pressing portion, having a first non-pressed position and a second pressed position, wherein when the wire pressing portion is in the second pressed position the wire pressing portion acts upon an insulated wire received by the wire conduit and terminates the wire into electrical connection with the first contact portion of a corresponding at least one conductive terminal.
2. The electrical connector jack of claim **1**, wherein the housing further comprises a strain relief tab.
3. The electrical connector jack of claim **1**, wherein first end opening of the conduit is located on a first face of the housing, and wherein the second end opening of the conduit is located on a second face of the housing.
4. The electrical connector jack of claim **3**, wherein the wire pressing portion is movable between a first non-pressed and a second pressed position in a direction substantially parallel to the direction of extension of the plug socket opening into the housing.
5. The electrical connector jack of claim **1**, wherein the first contact portion has a sharpness sufficient to pierce the insulation of the at least one insulated wire.
6. The electrical connector jack of claim **1**, wherein the housing is assembled from at least two pieces.
7. The electrical connector jack of claim **1**, wherein the at least one insulated wire is perpendicularly aligned with the first contact portion, wherein the insulation of the wire is pierced by the first contact portion when the pressing portion is moved to a pressed position.
8. A method for assembling an electrical connector jack, the method comprising:
 - providing a housing, having a plug socket;
 - providing at least one conductive terminal within the housing, the conductive terminal having a first contact portion and a second contact portion;
 - providing a conduit through the housing and extending from a first end opening in the housing to a second end

11

opening in the housing, wherein the first contact portion of the at least one conductive terminal is within the conduit;

providing a wire pressing portion, the wire pressing portion being movable with respect to the housing;

feeding at least one insulated wire into the first end opening of the conduit and out of the second end opening of the conduit, so that the at least one insulated wire extends out of the housing;

pulling tight at least one insulated wire within the conduit from the end extending from the second end opening; and

moving the wire pressing portion until the tightened at least one insulated wire within the conduit is terminated and held in electrical contact with the first contact portion of a corresponding at least one conductive terminal.

9. The method of claim 8, wherein the housing is assembled from at least two pieces.

10. The method of claim 8, further comprising untwisting and orienting the at least one insulated wire prior to feeding the at least one insulated wire into the first conduit.

12

11. The method of claim 8, further comprising clipping off the at least one insulated wire after the at least one insulated wire has been terminated with the first contact portion.

12. The method of claim 8, wherein the at least one insulated wire is perpendicularly aligned with the first contact portion, wherein the insulation of at least one insulated wire is pierced by the first contact portion when the terminating portion is moved.

13. An electrical connector jack comprising:
 a housing, having a plug socket;
 at least one conductive terminal within the housing, the conductive terminal having a first contact portion and a second contact portion;
 a conduit extending through the housing from a first end opening, for receiving at least one insulated wire, to a second end opening, through which a received at least one insulated wire protrudes beyond the housing, wherein the first contact portion of the at least one conductive terminal is within the conduit; and
 movable means for terminating and securing the received at least one insulated wire in electrical connection with the first contact portion.

* * * * *