

US007868262B2

(12) **United States Patent**
Whitaker et al.

(10) **Patent No.:** **US 7,868,262 B2**
(45) **Date of Patent:** **Jan. 11, 2011**

(54) **ELECTRICAL SWITCHING APPARATUS,
AND SUB-ASSEMBLY AND AUXILIARY
SWITCH TRAY THEREFOR**

(75) Inventors: **Thomas A. Whitaker**, N. Huntingdon,
PA (US); **Erik R. Bogdon**, Carnegie, PA
(US); **Glen C. Sisson**, Monaca, PA (US);
Ronald W. Brand, Beaver Falls, PA
(US); **James M. Smeltzer**, Salem, OH
(US); **Robert S. Estok**, Moon Township,
PA (US); **Craig A. Rodgers**, Butler, PA
(US)

(73) Assignee: **Eaton Corporation**, Cleveland, OH
(US)

(*) Notice: Subject to any disclaimer, the term of this
patent is extended or adjusted under 35
U.S.C. 154(b) by 958 days.

(21) Appl. No.: **11/692,517**

(22) Filed: **Mar. 28, 2007**

(65) **Prior Publication Data**

US 2008/0237007 A1 Oct. 2, 2008

(51) **Int. Cl.**
H01H 1/64 (2006.01)
H01H 1/66 (2006.01)

(52) **U.S. Cl.** **200/293; 335/132**

(58) **Field of Classification Search** **200/293**
See application file for complete search history.

(56) **References Cited**

U.S. PATENT DOCUMENTS

4,254,316 A * 3/1981 Landow 200/308
4,297,663 A 10/1981 Seymour et al.

4,485,365 A 11/1984 Lerud et al.
4,678,873 A * 7/1987 Preuss et al. 200/18
5,638,948 A * 6/1997 Sharaf et al. 200/401
6,232,855 B1 5/2001 Malingowski et al.
6,232,859 B1 5/2001 Christensen et al.
6,255,926 B1 7/2001 Gundy et al.
7,023,303 B1 4/2006 Bogdon et al.
7,064,635 B2 6/2006 Bogdon et al.
2006/0071740 A1 4/2006 Bogdon et al.
2006/0071741 A1 4/2006 Bogdon et al.
2006/0071744 A1 4/2006 Bogdon et al.

FOREIGN PATENT DOCUMENTS

DE 196 17 135 A1 10/1997
DE 20 2005 015448 A1 12/2005

* cited by examiner

Primary Examiner—Renee Luebke

Assistant Examiner—Lheiren Mae A Caroc

(74) *Attorney, Agent, or Firm*—Martin J. Moran

(57) **ABSTRACT**

An auxiliary switch tray is provided for an electrical switching apparatus, such as a circuit breaker. The circuit breaker includes a housing, an actuating mechanism, and a plurality of auxiliary switches. The housing has a mounting mechanism. The auxiliary switch tray includes a module having first and second sides, and a plurality of mounts disposed on the first side. At least a plurality of the mounts is structured to receive a corresponding one of the auxiliary switches. A base is disposed on the second side of the module and is coupled to the mounting mechanism in order to install the auxiliary switches in a predetermined position with respect to the actuating mechanism of the circuit breaker. The module, the mounts, and the base comprise one single-piece molded member. At least a plurality of the mounts are molded compartments of the single-piece molded member.

12 Claims, 13 Drawing Sheets

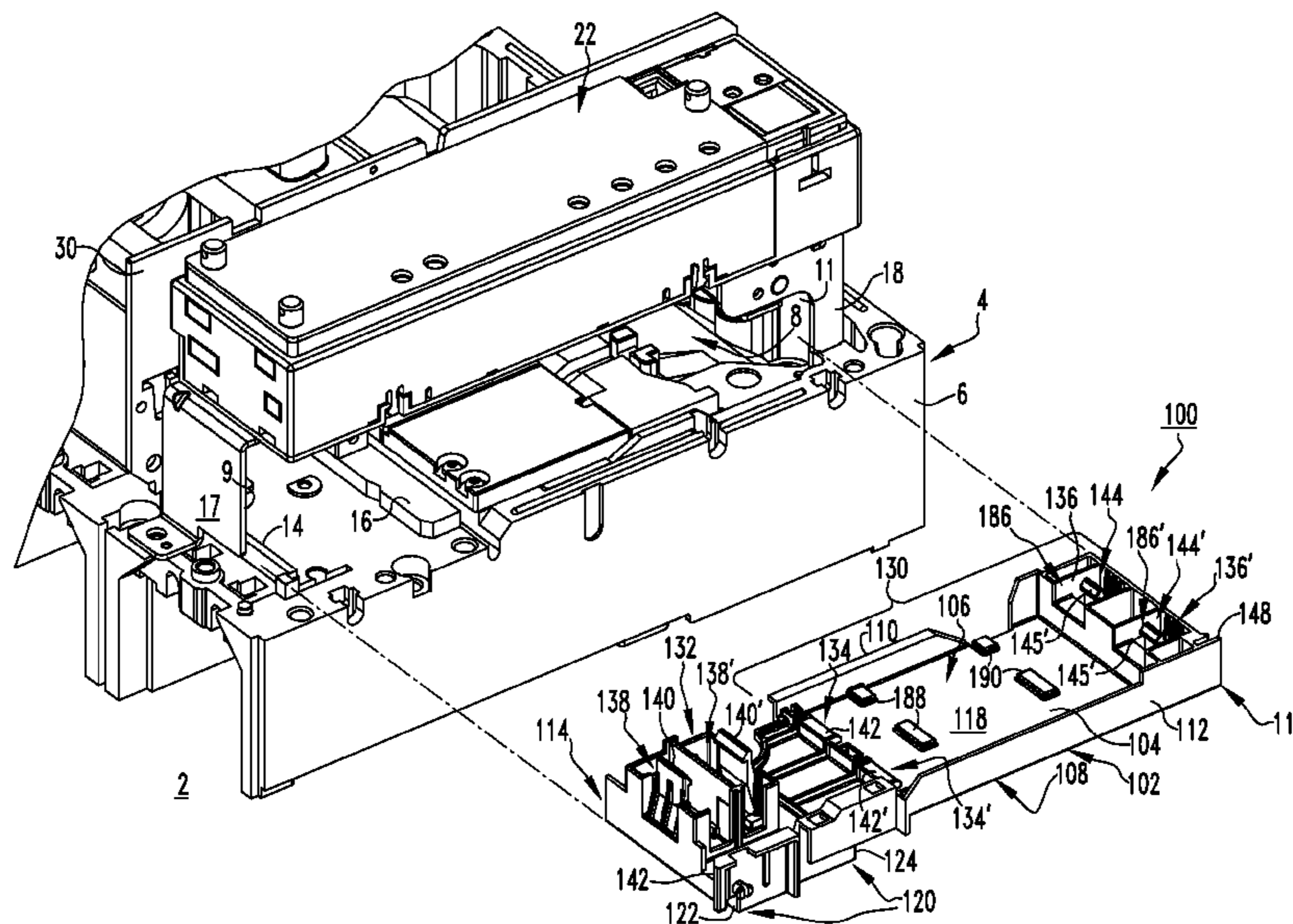

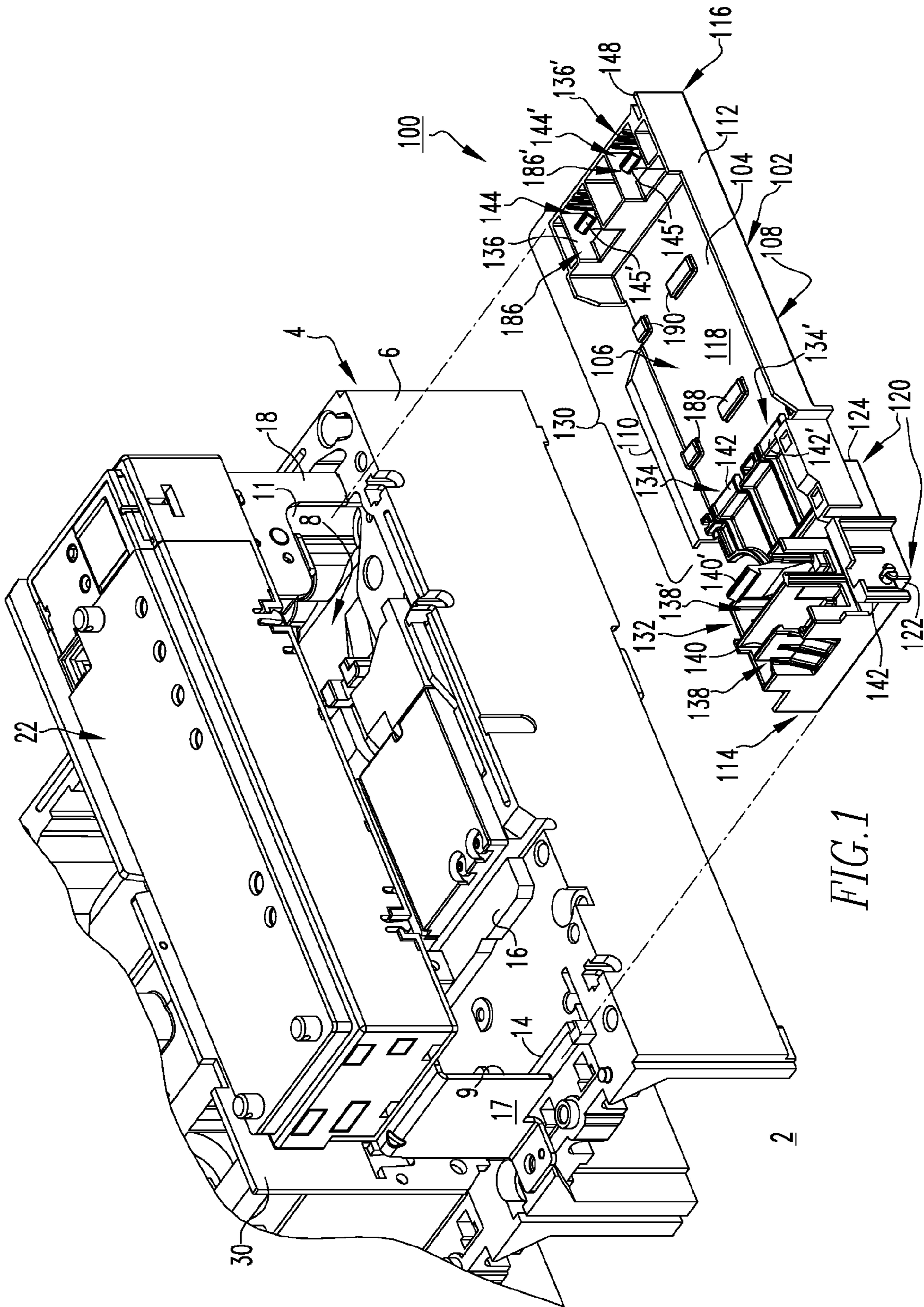

FIG. 1

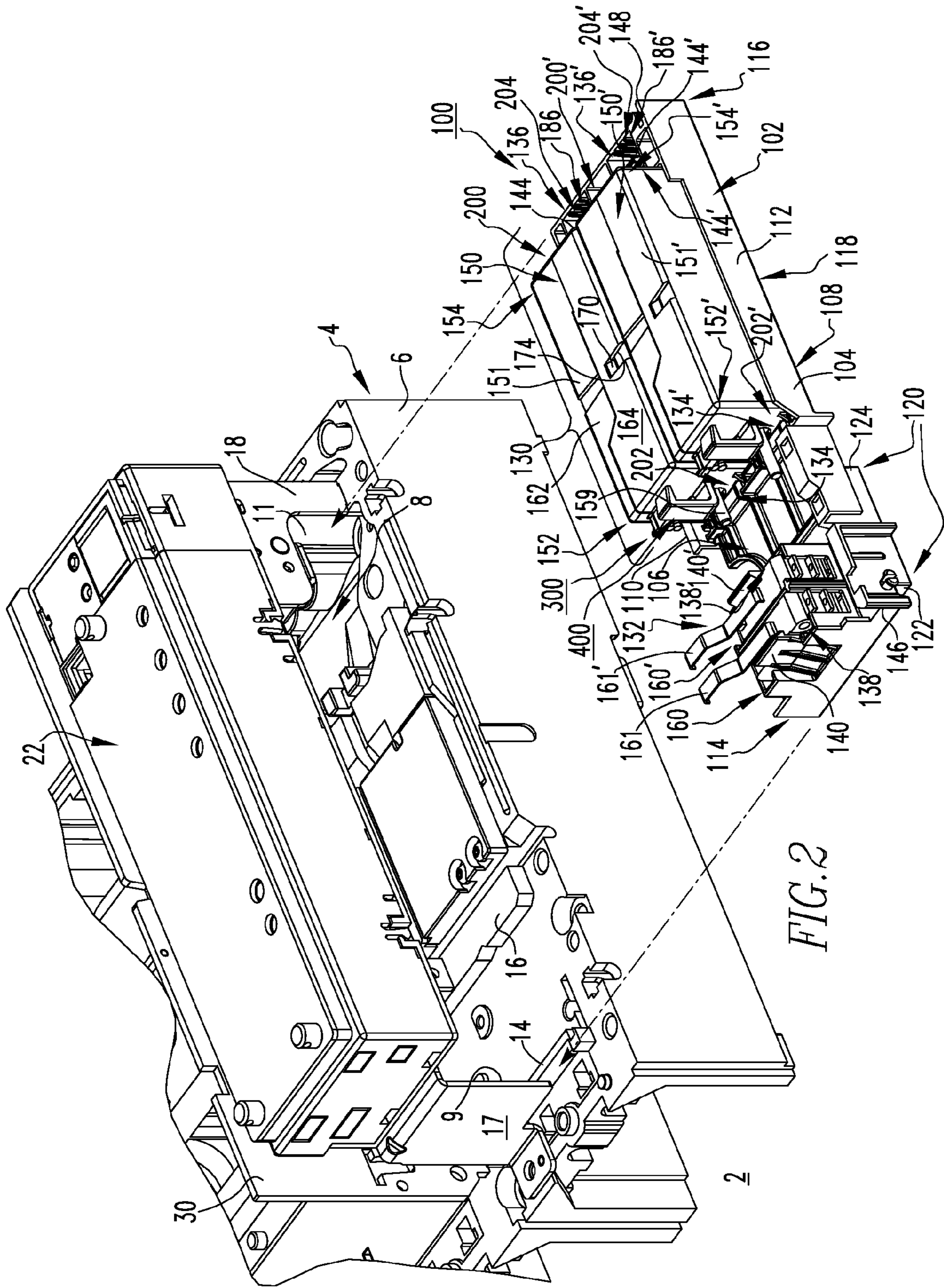

FIG. 2

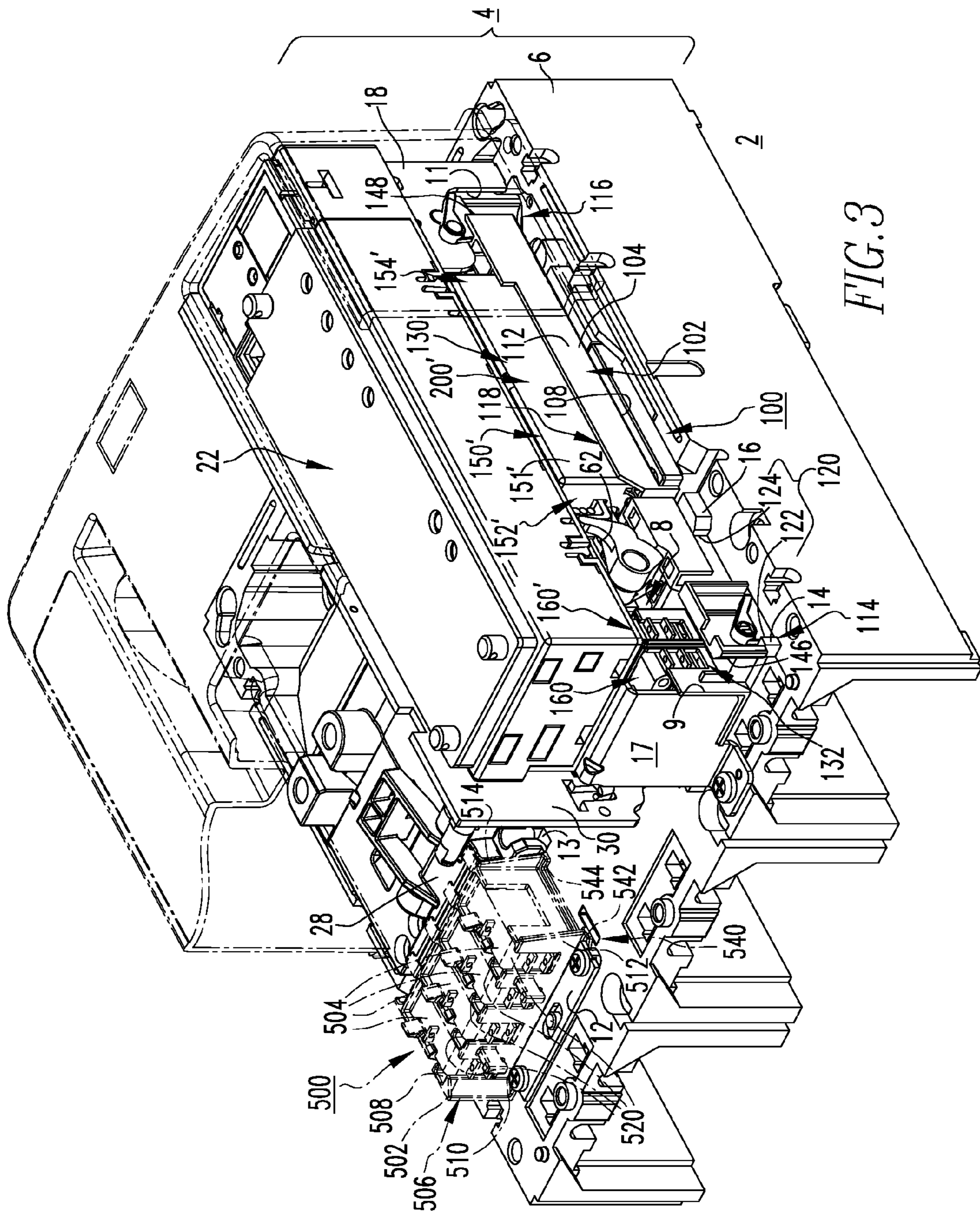
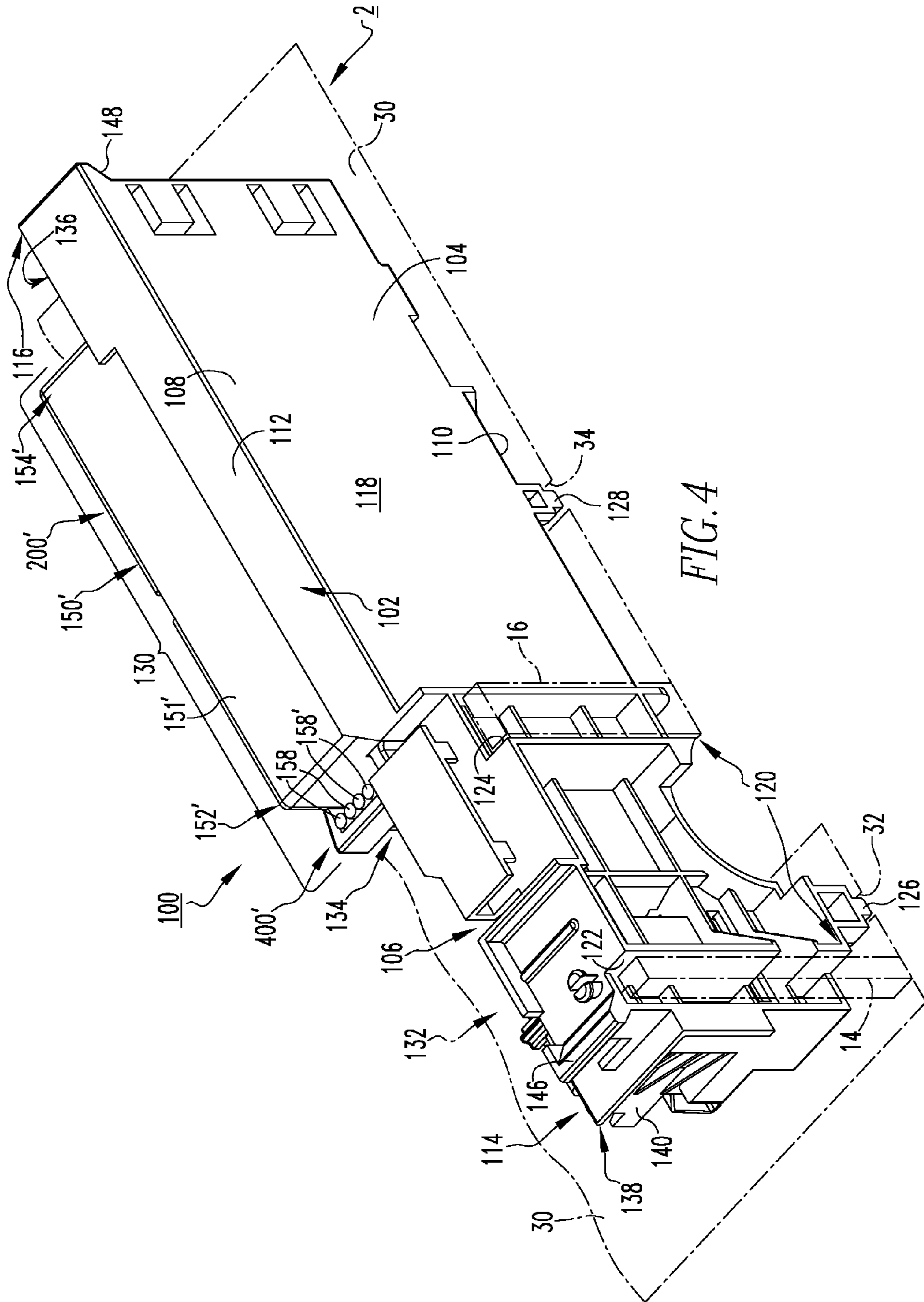
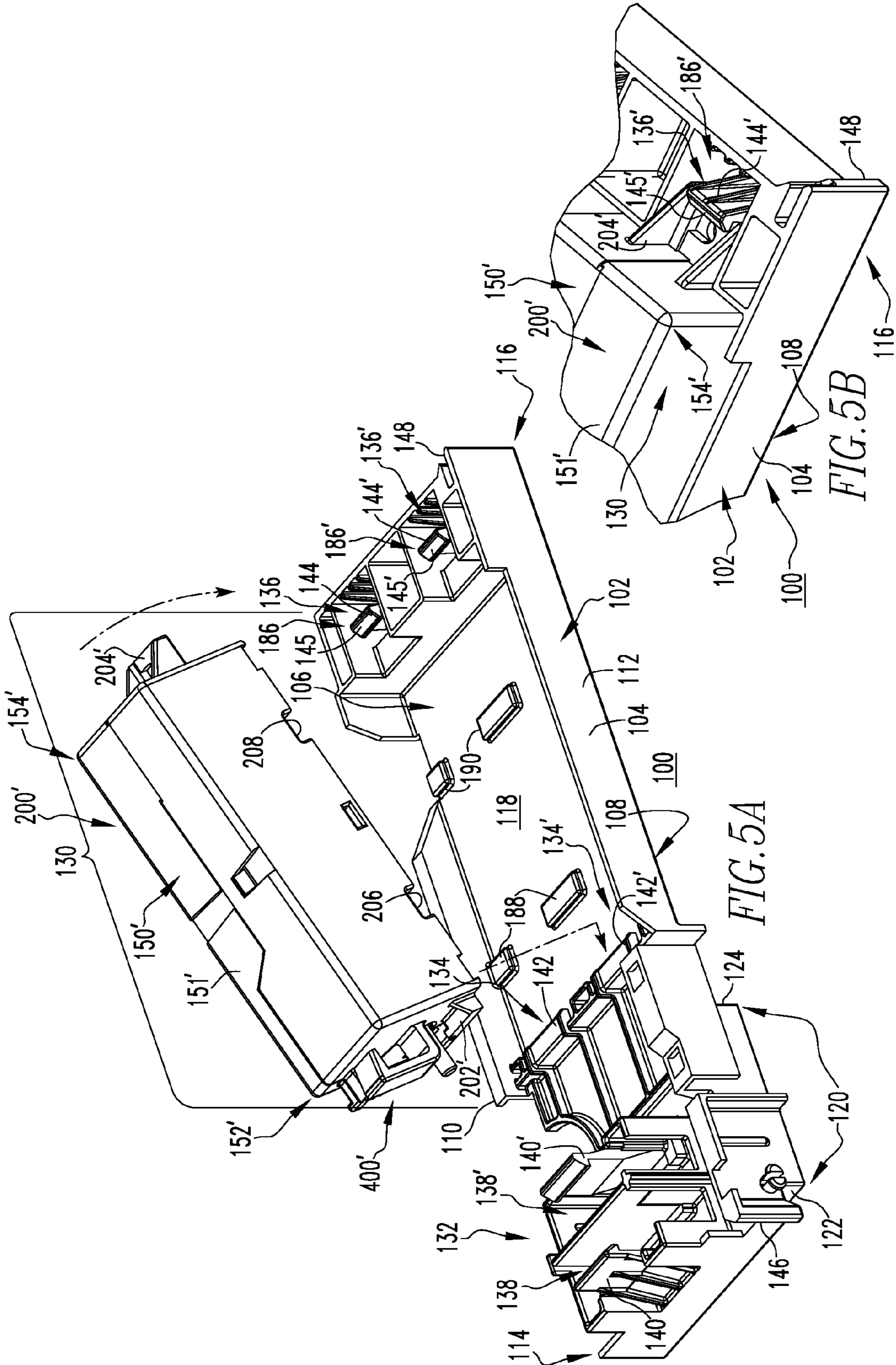
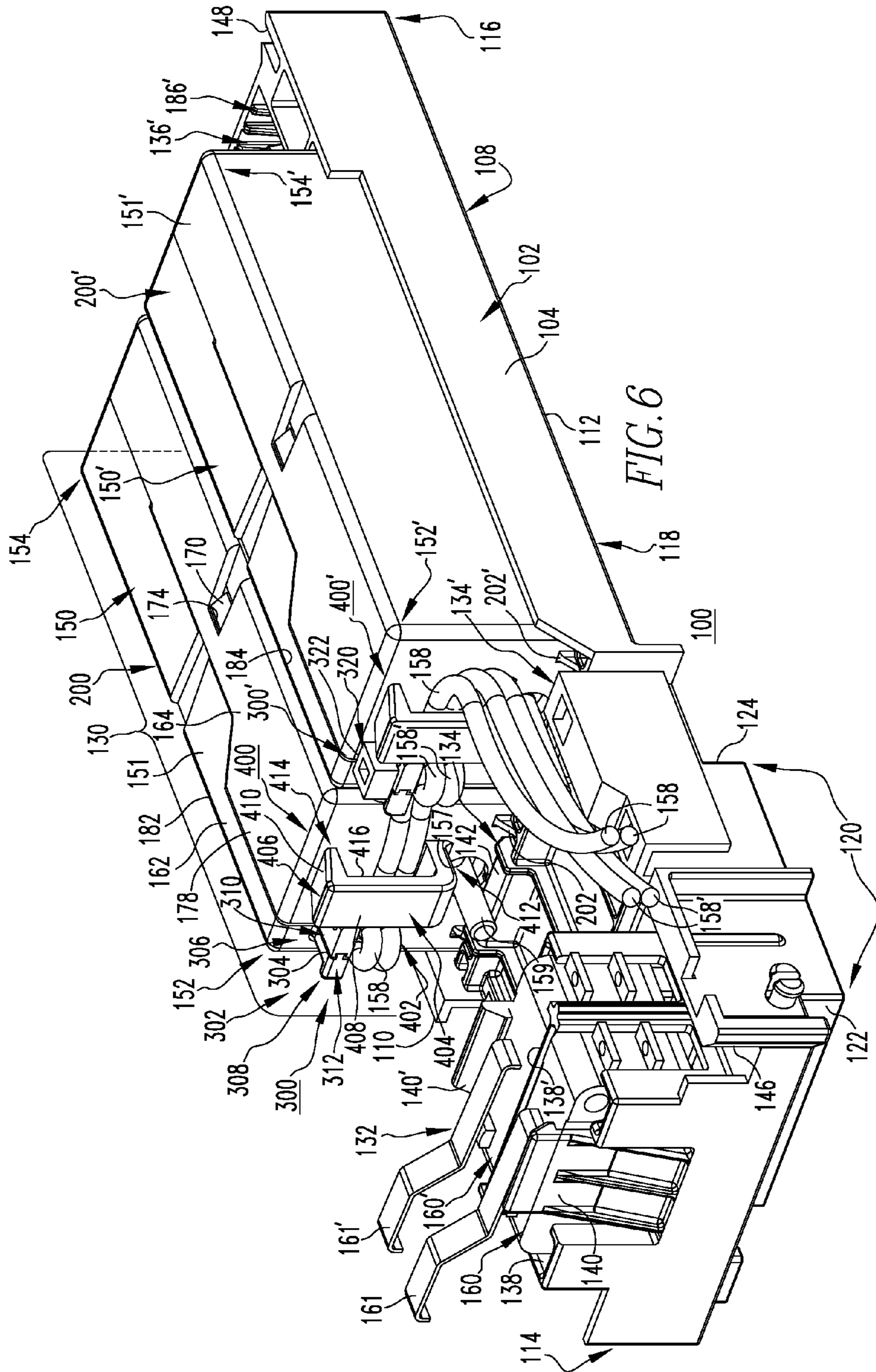
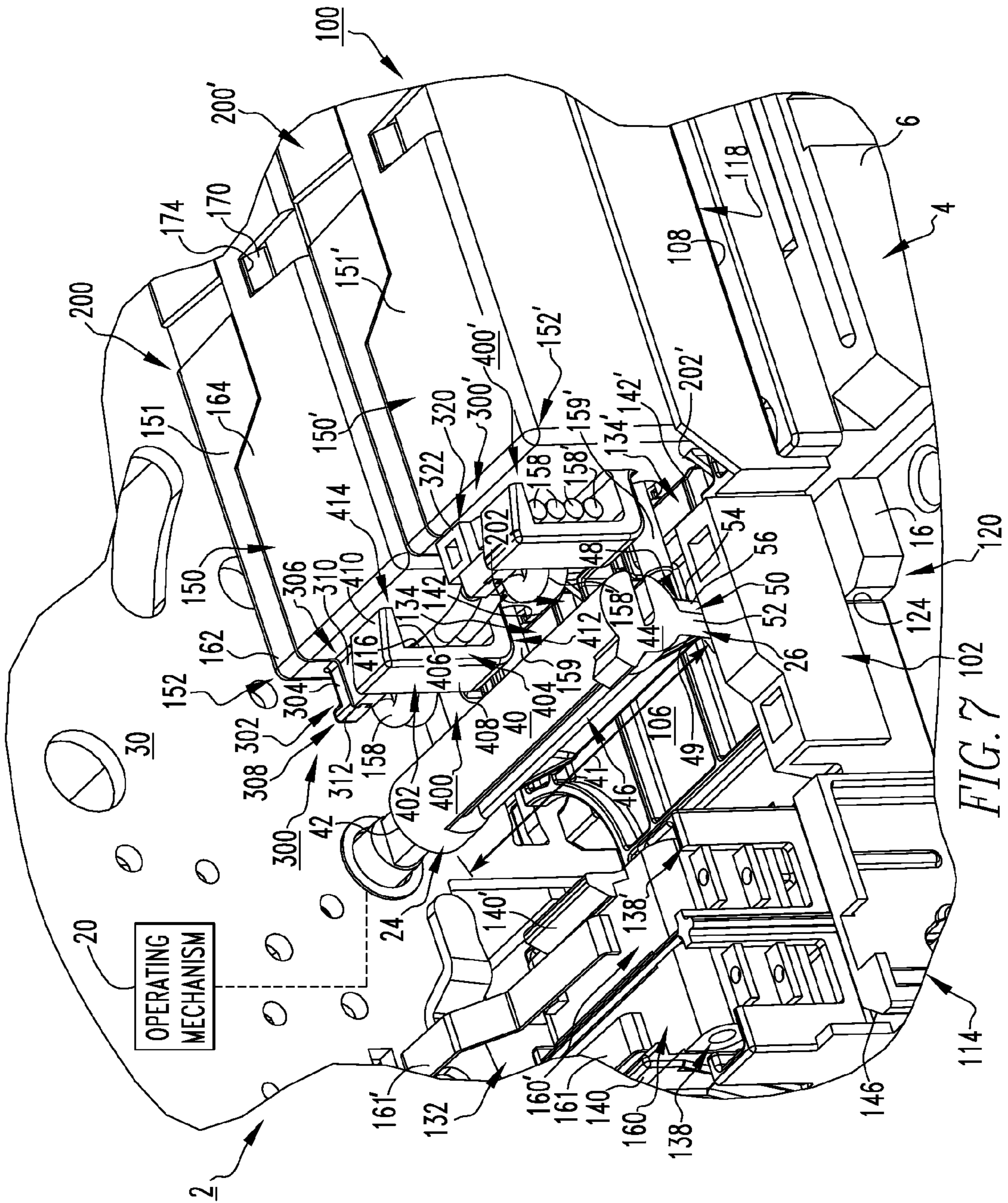

FIG. 3









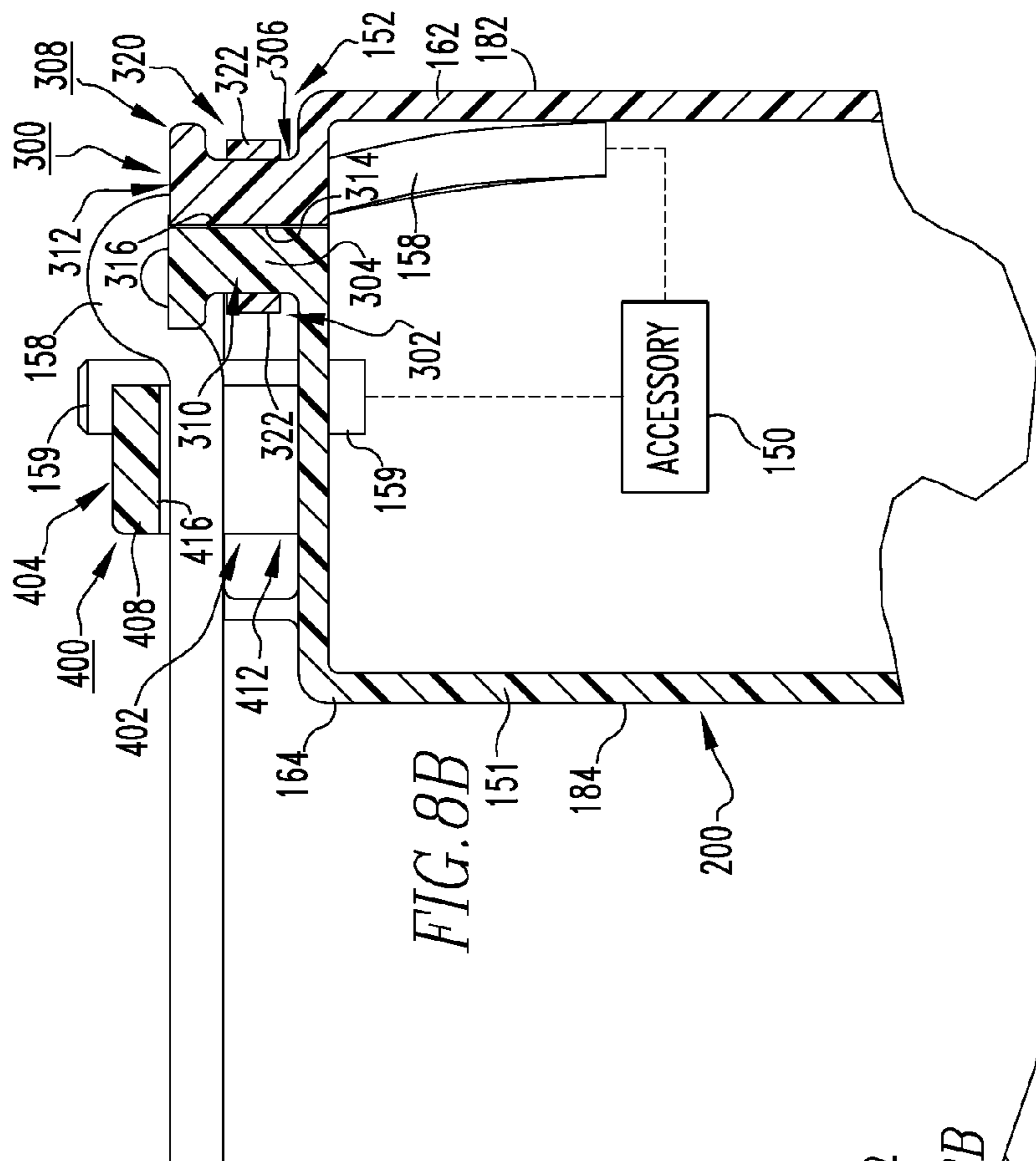

FIG. 8B

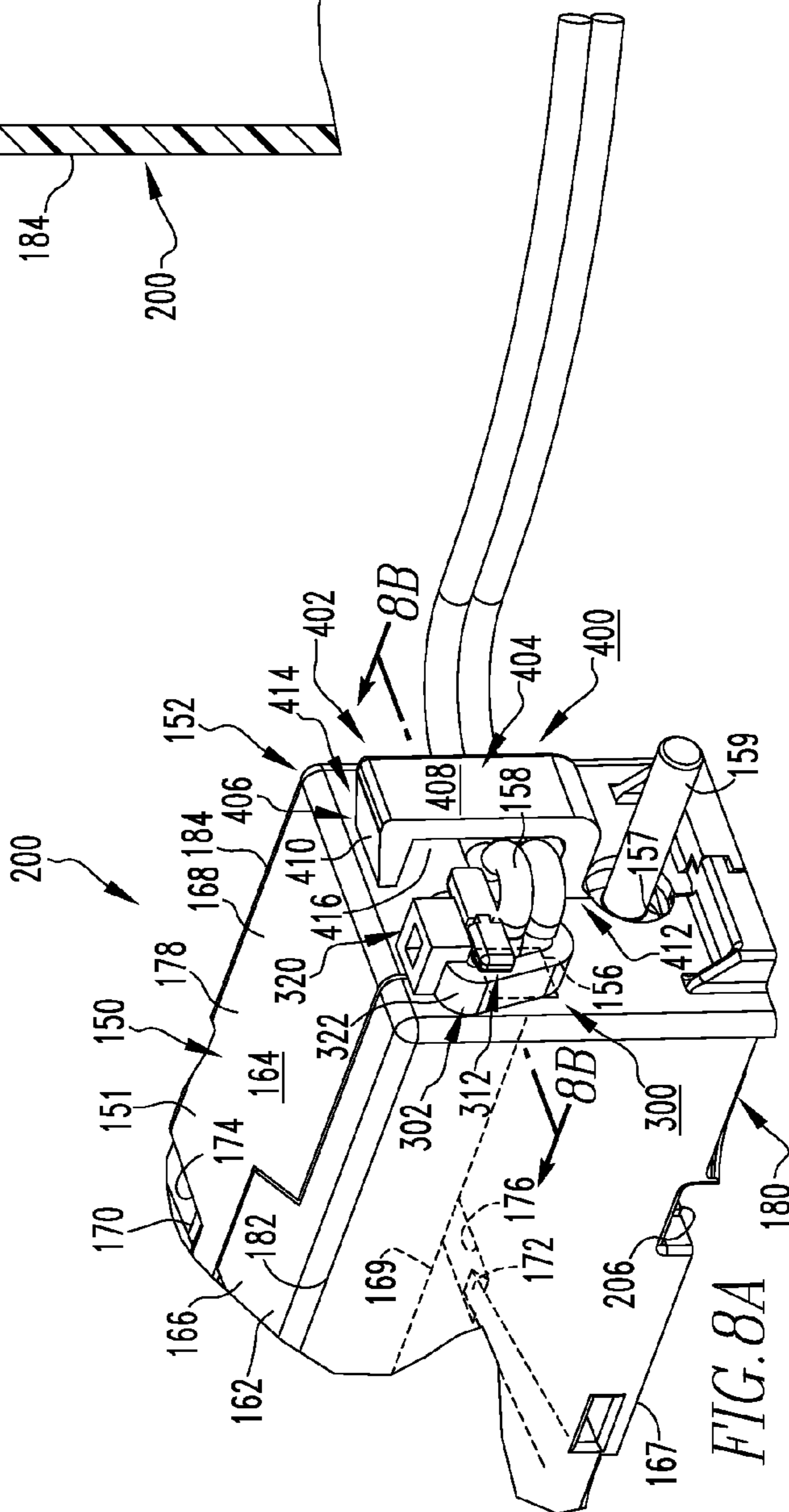
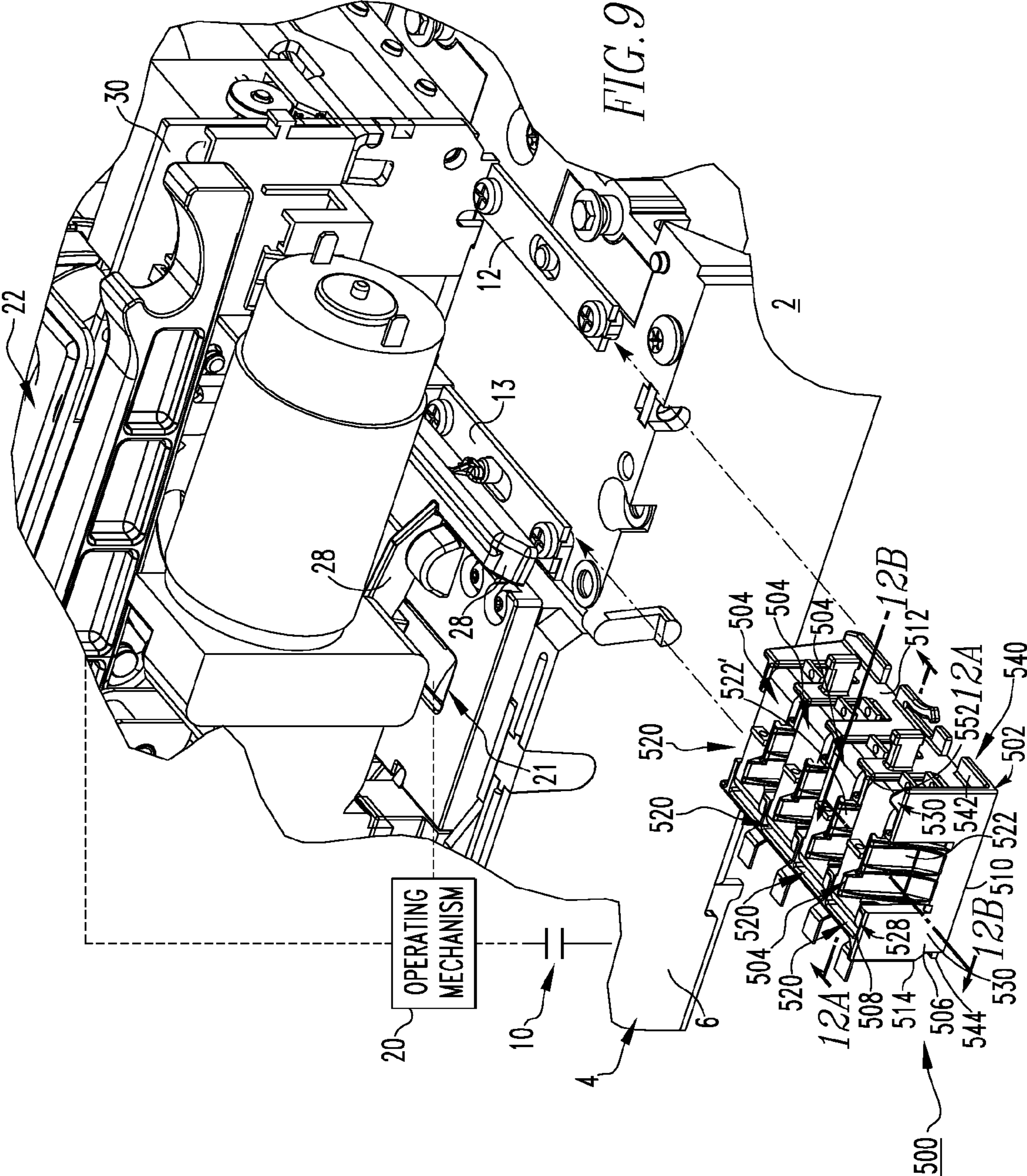

FIG. 8A



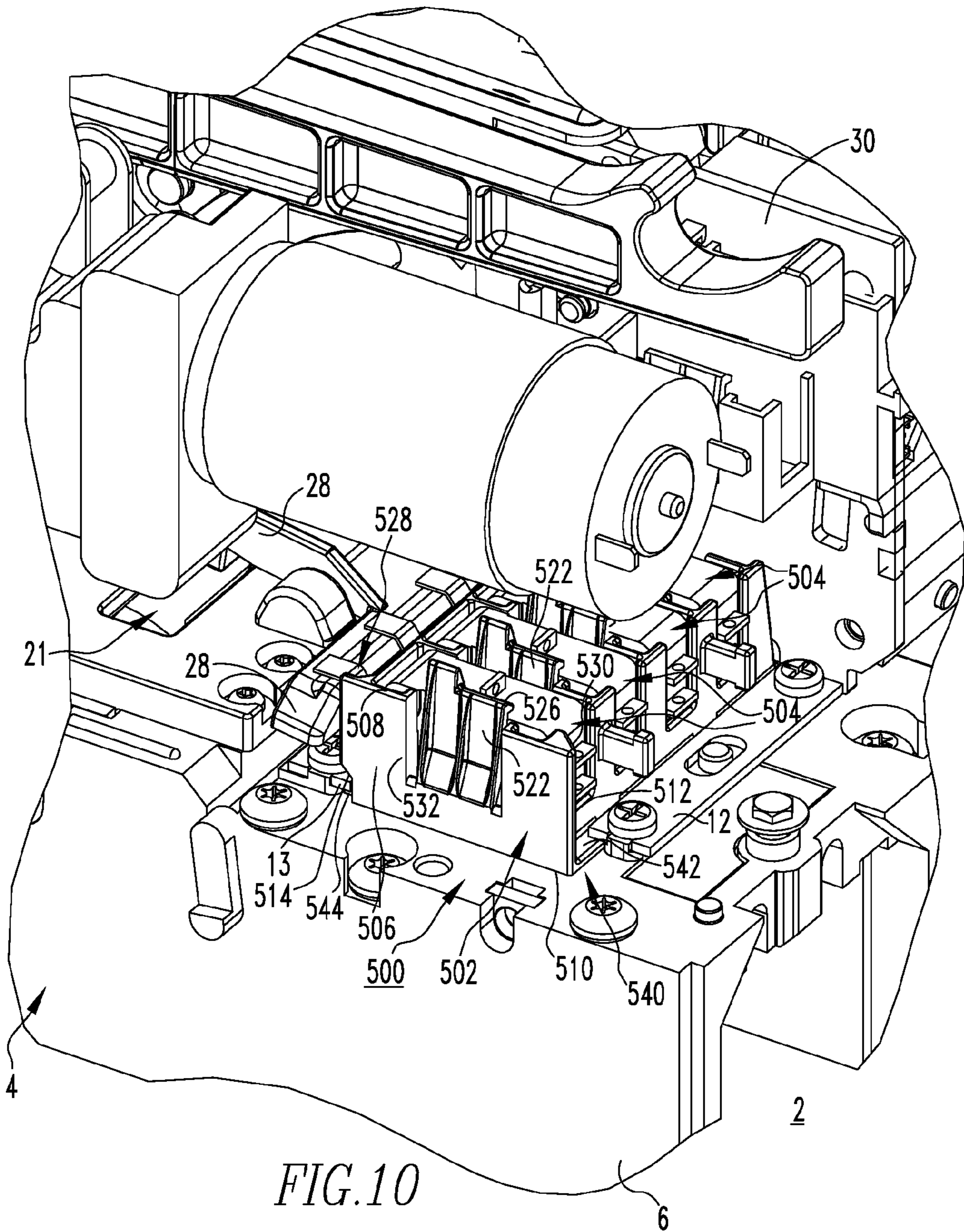

FIG. 10

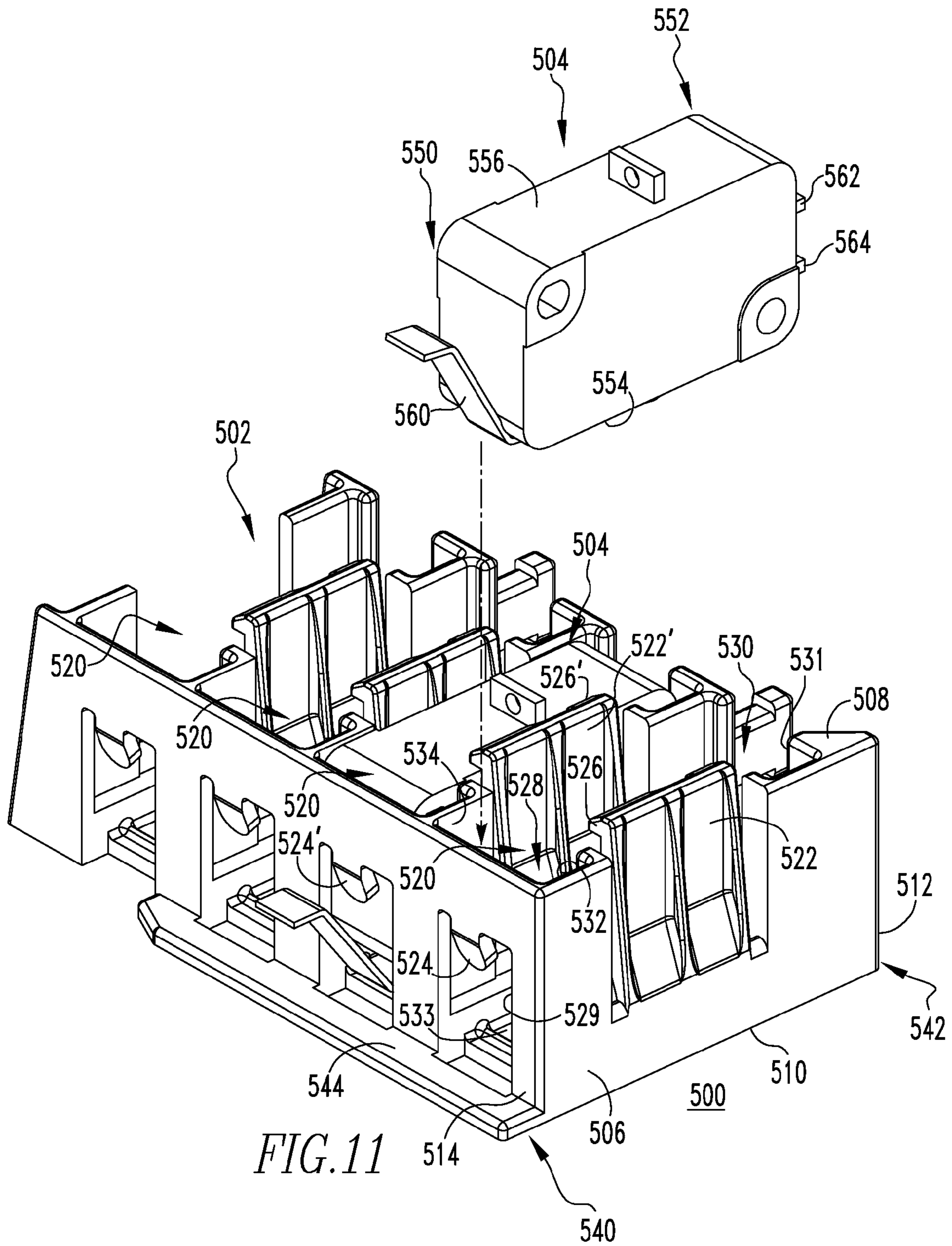
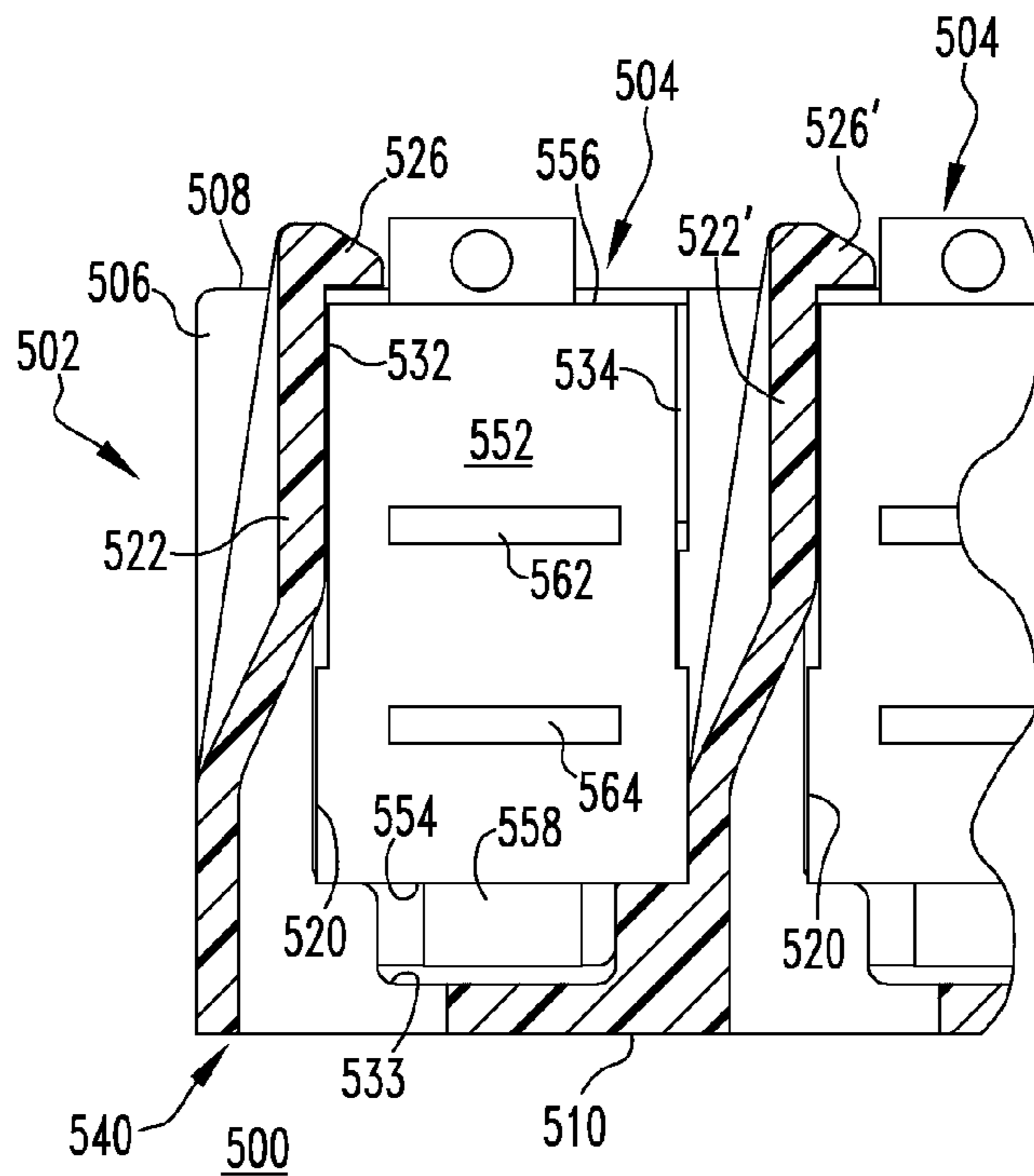
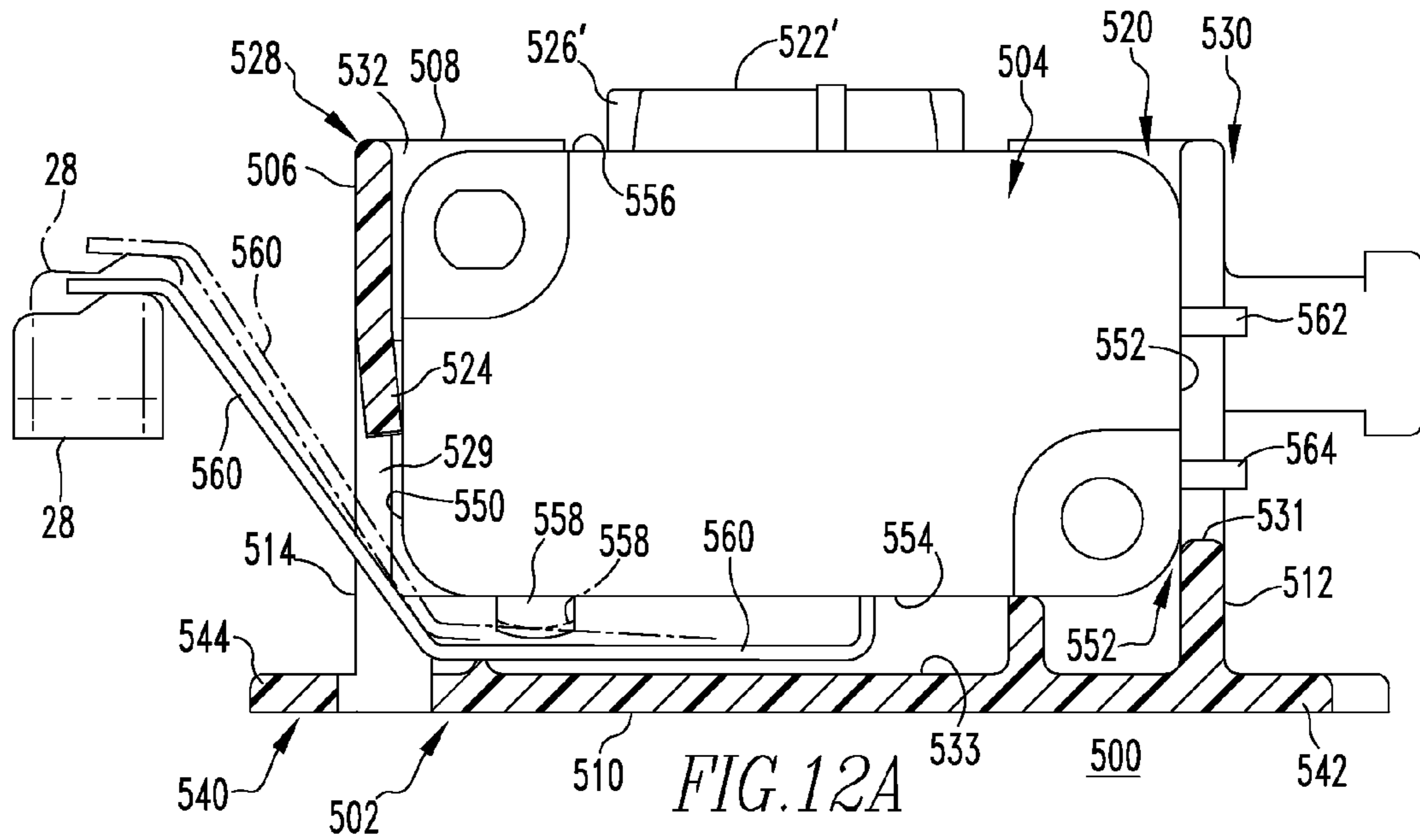
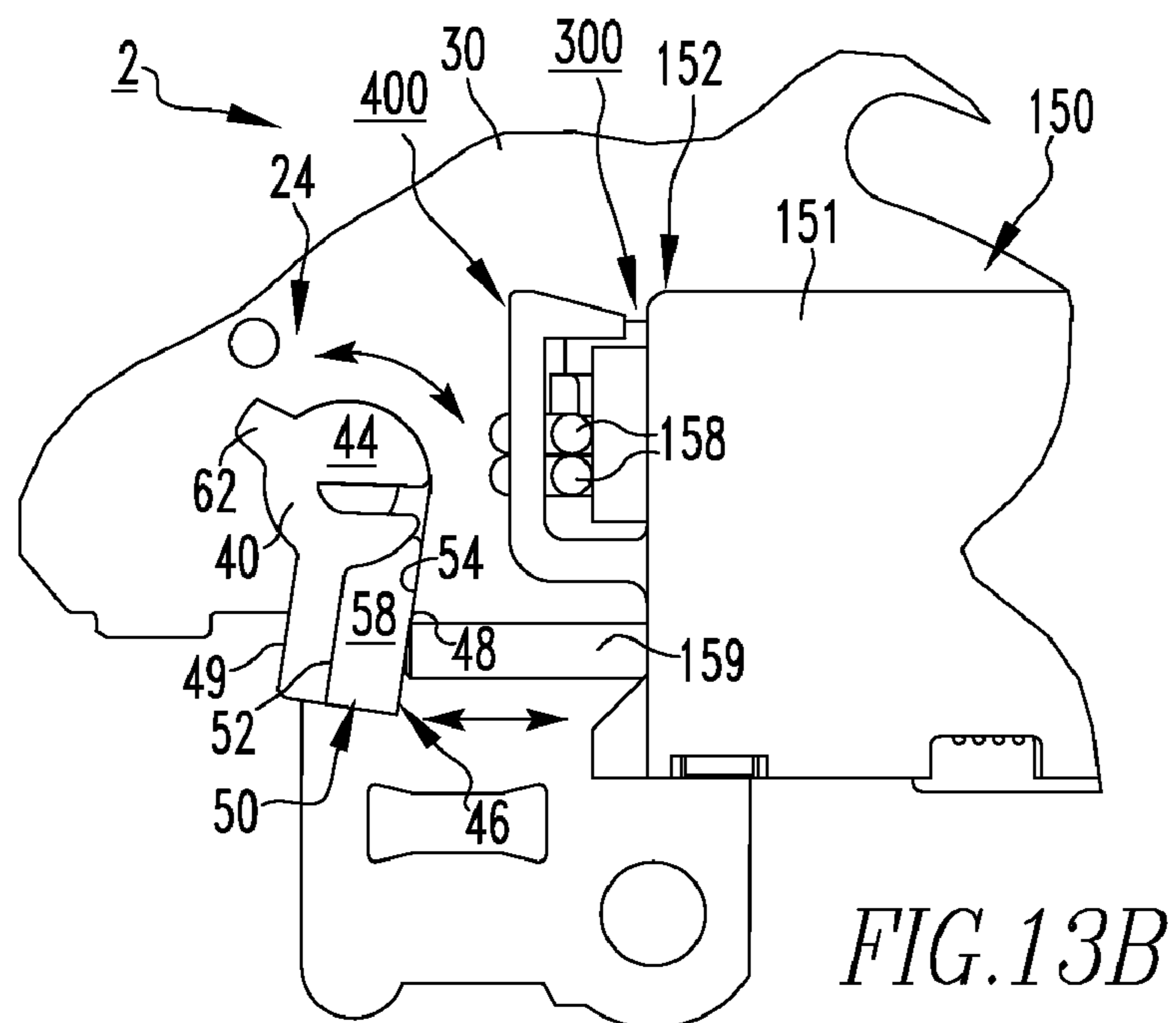
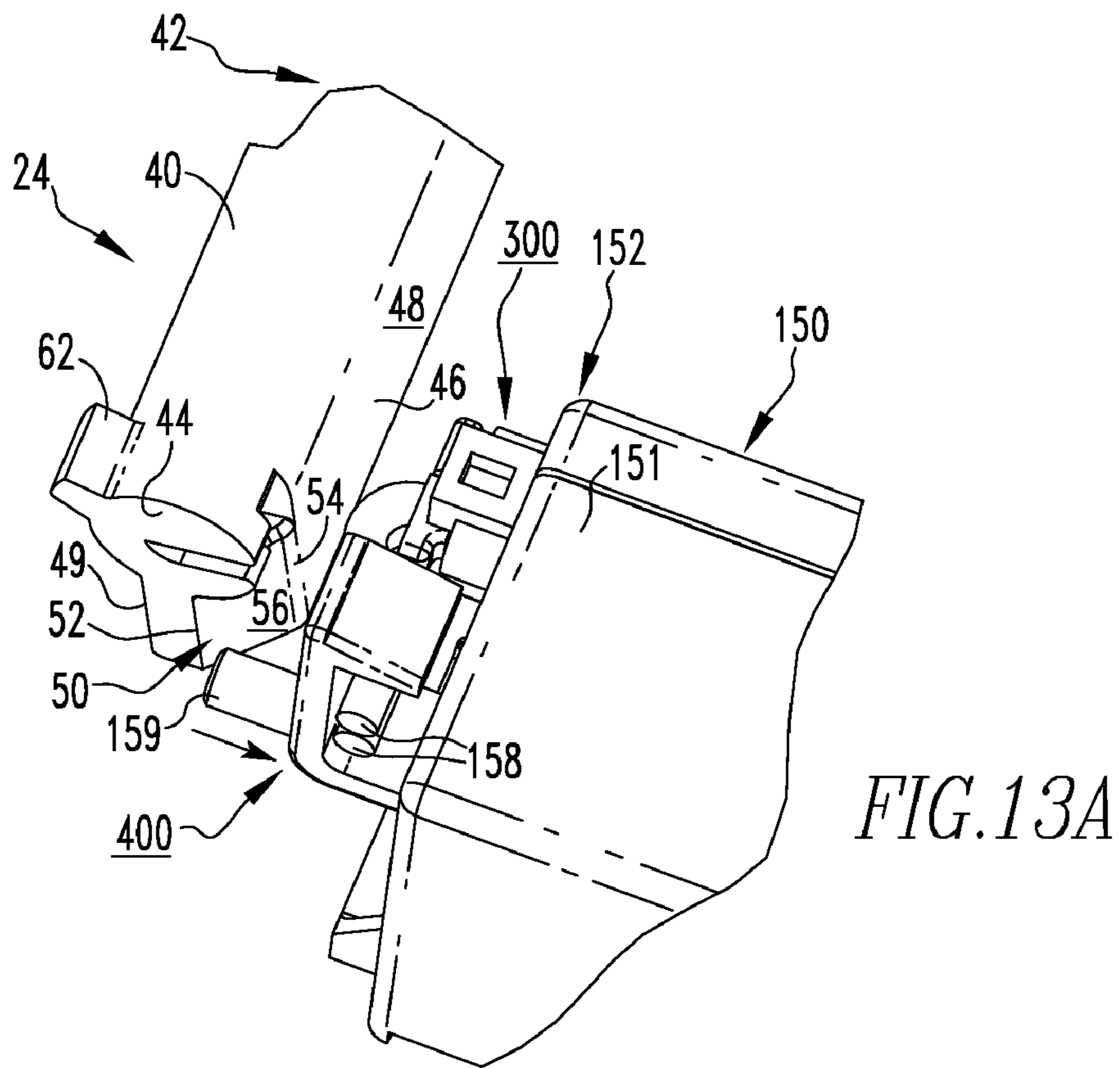

FIG. 11





**ELECTRICAL SWITCHING APPARATUS,
AND SUB-ASSEMBLY AND AUXILIARY
SWITCH TRAY THEREFOR**

CROSS-REFERENCE TO RELATED
APPLICATIONS

This application is related to commonly assigned, concurrently filed:

U.S. patent application Ser. No. 11/692,488, filed Mar. 28, 2007, entitled "ELECTRICAL SWITCHING APPARATUS AND ACCESSORY ASSEMBLY THEREFOR";

U.S. patent application Ser. No. 11/692,495 filed Mar. 28, 2007, entitled "ELECTRICAL SWITCHING APPARATUS, AND ACCESSORY MODULE AND STRAIN RELIEF MECHANISM THEREFOR";

U.S. Pat. No. 7,598,834, issued Oct. 6, 2009, entitled "ELECTRICAL SWITCHING APPARATUS AND ACCESSORY TRAY THEREFOR";

U.S. Pat. No. 7,645,953 issued Jan. 12, 2010, entitled "ELECTRICAL SWITCHING APPARATUS, AND ACCESSORY MODULE AND ELECTRICAL CONDUCTOR MOUNT THEREFOR", and

U.S. Pat. No. 7,385,153 issued Jun. 10, 2008, entitled "ELECTRICAL SWITCHING APPARATUS AND TRIP BAR THEREFOR", which are hereby incorporated herein by reference.

BACKGROUND OF THE INVENTION

1. Field of the Invention

The invention relates generally to electrical switching apparatus and, more particularly, to sub-assemblies for electrical switching apparatus, such as circuit breakers. The invention also relates to auxiliary switch trays for circuit breaker sub-assemblies.

2. Background Information

Electrical switching apparatus, such as circuit breakers, as well as transfer switches, network protectors and the like, are often equipped with accessories such as, for example and without limitation, auxiliary switches, shunt trip devices, under voltage release devices, and bell alarms. Such devices can be employed in a variety of ways to provide signals indicating certain conditions within the apparatus and/or to initiate a change in status of the apparatus such as, for example, to trip open the separable contacts of the apparatus in response to an electrical fault condition (e.g., without limitation, current overload; short circuit; abnormal voltage).

In view of the increasing market trend to reduce the overall size of the circuit breaker, the space which is available within the circuit breaker housing is limited. In addition to size constraints, the location available for mounting accessories within the circuit breaker can also be problematic. For example, some locations for mounting the accessories in the circuit breaker have limited access for installing the accessories and, in some instances, blind installation is required, wherein it is not possible to mount the accessory within the circuit breaker housing. As a result, incorrect installation and/or damage to the accessories can result, and safety features of the circuit breaker can be adversely affected.

Traditionally, in order for various accessories to fit within the circuit breaker, they sometimes had to be custom made or modified. For example, auxiliary switches often consist of the combination of a micro-switch and a customized bracket, mount or shell which is required in order to adapt the micro-switch for proper installation in the circuit breaker. It is desirable to be able to use a variety of circuit breaker accessories

such as, for example, micro-switches, in their stock or unaltered form, without requiring the micro-switch to be modified or a customized bracket, mount, or shell to be made. It is also desirable to be able to quickly and accurately removably install a plurality of auxiliary switches within the circuit breaker.

There is, therefore, room for improvement in electrical switching apparatus, such as circuit breakers, and in sub-assemblies therefor.

SUMMARY OF THE INVENTION

These needs and others are met by embodiments of the invention, which are directed to a sub-assembly and auxiliary switch tray for securely and accurately, removably mounting a plurality of auxiliary switches in an electrical switching apparatus (e.g., without limitation, a circuit breaker), without requiring the auxiliary switches to be modified or a customized bracket, mount, or shell to be made.

As one aspect of the invention, an auxiliary switch tray is provided for an electrical switching apparatus. The electrical switching apparatus includes a housing, an actuating mechanism, and a plurality of auxiliary switches. The housing has a mounting mechanism. The auxiliary switch tray comprises: a module including a first side and a second side disposed opposite the first side; a plurality of mounts disposed on the first side, each of the mounts being structured to receive a corresponding one of the auxiliary switches; and a base disposed on the second side of the module, the base being structured to be coupled to the mounting mechanism in order to install the auxiliary switches in a predetermined position with respect to the actuating mechanism of the electrical switching apparatus.

Each of the mounts may be structured to removably secure the corresponding one of the auxiliary switches to the module without a number of separate fasteners. Each of the mounts may be a compartment structured to receive the corresponding one of the auxiliary switches. The compartment may comprise a first resilient tab and a second resilient tab, wherein the first resilient tab includes a retaining portion structured to retain the corresponding one of the auxiliary switches within the compartment, and wherein the second resilient tab is structured to bias the corresponding one of the auxiliary switches into a desired orientation within the compartment. The compartment may further comprise a first end, a second end disposed opposite and distal from the first end, a first side, and a second side disposed opposite and spaced apart from the first side of the compartment. The first resilient tab may be disposed on the first side of the compartment, and the retaining portion of the first resilient tab may be a molded hook extending from at or about the first side of the molded compartment toward the second side of the compartment. The second resilient tab may extend from the first end of the compartment toward the second end of the compartment.

The mounting mechanism of the electrical switching apparatus may include a first portion and a second portion. The module may further include a first edge and a second edge disposed opposite and distal from the first edge of the module, wherein the base comprises a first lateral protrusion extending outwardly from the first edge of the module at or about the second side of the module, and a second lateral protrusion extending outwardly from the second edge of the module at or about the second side of the module. The module may be structured to be removably insertable into the electrical switching apparatus. When the module is inserted into the electrical switching apparatus, the first lateral protrusion of the base of the module may be structured to engage the first

3

portion and the second lateral protrusion of the base of the module may be structured to engage the second portion in order to align the module with respect to the electrical switching apparatus and to install the auxiliary switches in the predetermined position.

The module, the mounts, and the base may comprise one single-piece molded member.

As another aspect of the invention, a sub-assembly is provided for an electrical switching apparatus including a housing having a mounting mechanism, and an actuating mechanism. The sub-assembly comprises: a plurality of auxiliary switches; and an auxiliary switch tray comprising: a module including a first side and a second side disposed opposite the first side, a plurality of mounts disposed on the first side of the module, each of the mounts receiving a corresponding one of the auxiliary switches, and a base disposed on the second side of the module and being removably coupled to the mounting mechanism, in order to install the auxiliary switches in a predetermined position with respect to the actuating mechanism of the electrical switching apparatus.

As another aspect of the invention, an electrical switching apparatus comprises: a housing; separable contacts enclosed by the housing; an operating mechanism structured to open and close the separable contacts, the operating mechanism including an actuating mechanism; and a sub-assembly comprising: a plurality of auxiliary switches being cooperable with the actuating mechanism, and an auxiliary switch tray comprising: a module including a first side and a second side disposed opposite the first side, a plurality of mounts disposed on the first side of the module, each of the mounts receiving a corresponding one of the auxiliary switches, and a base disposed on the second side of the module, the base being removably coupled to the mounting mechanism, in order to install the auxiliary switches in a predetermined position with respect to the actuating mechanism of the electrical switching apparatus.

The electrical switching apparatus may be a circuit breaker. The actuating mechanism of the circuit breaker may comprise an auxiliary paddle. The mounts of the module of the auxiliary switch tray may be four molded compartments of the module, and the plurality of auxiliary switches may be four auxiliary switches. Each of the molded compartments may receive and removably secure a corresponding one of the auxiliary switches, and each of the auxiliary switches may include an actuating lever. When the auxiliary switch tray is installed in the circuit breaker, the actuating lever of such each of the auxiliary switches may be disposed proximate to the auxiliary paddle and may be actuable by the auxiliary paddle.

Each of the auxiliary switches may comprise a micro-switch including a switch, a lever cooperable with the switch, and a number of terminals. Each of the mounts of the module of the auxiliary switch tray may be a molded compartment. The molded compartment may include a first end having an opening, a second end disposed opposite and distal from the first end of the molded compartment, a first side comprising a molded recess, and a second side disposed opposite and distal from the first side and including an access hole. The micro-switch may be removably securable within the molded compartment. When the micro-switch is disposed in the molded compartment, the lever may extend through the opening, the

4

switch may be received by the molded recess, and the number of terminals may be accessible through the access hole.

BRIEF DESCRIPTION OF THE DRAWINGS

A full understanding of the invention can be gained from the following description of the preferred embodiments when read in conjunction with the accompanying drawings in which:

FIG. 1 is an exploded isometric view of a portion of a circuit breaker and an accessory tray therefor;

FIG. 2 is an exploded isometric view of the portion of the circuit breaker and accessory tray therefor of FIG. 1, modified to show circuit breaker accessories mounted on the accessory tray;

FIG. 3 is an isometric view of the circuit breaker and accessory tray therefor of FIG. 2, showing the accessory tray in the installed position within the circuit breaker;

FIG. 4 is an isometric view of the underside of the accessory tray of FIG. 2;

FIG. 5A is an exploded isometric view of the accessory tray of FIG. 1, also showing an accessory module being installed thereon;

FIG. 5B is an assembled isometric view of a portion of the accessory tray of FIG. 5A, also showing the accessory module after being installed thereon;

FIG. 6 is an isometric view of the accessory tray of FIG. 2, modified to also show the electrical conductors of the accessory modules and electrical conductor mounts therefor;

FIG. 7 is an isometric close-up view of a portion of the accessory tray and accessory modules and electrical conductor mounts therefor of FIG. 6, also showing a portion of the circuit breaker, including the trip bar that the accessories actuate;

FIG. 8A is an isometric view of a portion of one of the accessory modules and strain relief mechanism therefor of FIG. 7;

FIG. 8B is a sectional view taken along line 8B-8B of FIG. 8A with some internal components being shown in block form;

FIG. 9 is an exploded isometric view of a portion of the circuit breaker of FIG. 1 and an auxiliary switch tray therefor, in accordance with an embodiment of the invention;

FIG. 10 is an assembled isometric view of the portion of the circuit breaker and auxiliary switch tray therefor of FIG. 9;

FIG. 11 is a partially exploded isometric view of the auxiliary switch tray of FIG. 9, showing one micro-switch mounted thereon and another micro-switch just prior to being mounted thereon;

FIG. 12A is a sectional view taken along line 12A-12A of FIG. 9;

FIG. 12B is a sectional view taken along line 12B-12B of FIG. 9;

FIG. 13A is an isometric view of a portion of the trip bar and a portion of one accessory module of FIG. 7, showing the stem of the accessory module engaging a cam surface of the trip bar as the accessory module is being installed; and

FIG. 13B is a side elevation view of the trip bar and portion of the accessory module of FIG. 13A modified to show the accessory module in the fully installed position with the stem engaging a paddle of the trip bar.

DESCRIPTION OF THE PREFERRED EMBODIMENTS

For purposes of illustration, embodiments of the invention will be described as applied to low-voltage circuit breakers,

5

although it will become apparent that they could also be applied to a wide variety of electrical switching apparatus (e.g., without limitation, circuit switching devices and other circuit interrupters, such as contactors, motor starters, motor controllers and other load controllers) other than low-voltage circuit breakers and other than low-voltage electrical switching apparatus.

Directional phrases used herein, such as, for example, left, right, top, bottom, upper, lower, front, back and derivatives thereof, relate to the orientation of the elements shown in the drawings and are not limiting upon the claims unless expressly recited therein.

As employed herein, the terms “actuator” and “actuating mechanism” refer to any known or suitable input or output mechanism for an electrical switching apparatus (e.g., without limitation, circuit switching devices and other circuit interrupters, such as contactors, motor starters, motor controllers and other load controllers) or accessory (e.g., without limitation, auxiliary switch; shunt trip device; under voltage release device; bell alarm) therefore, and expressly include, but are not limited to, stems, plungers, levers, buttons, switches, trip bars, paddles, and arms.

As employed herein, the term “fastener” shall mean a separate element or elements which is/are employed to connect or tighten two or more components together, and expressly includes, without limitation, rivets, pins, screws, bolts and the combinations of bolts and nuts (e.g., without limitation, lock nuts) and bolts, washers and nuts.

As employed herein, the statement that two or more parts are “coupled” together shall mean that the parts are joined together either directly or joined through one or more intermediate parts.

As employed herein, the term “number” shall mean one or an integer greater than one (i.e., a plurality).

FIGS. 1-3 show an electrical switching apparatus, such as a low-voltage circuit breaker 2, employing an accessory assembly 100 having an accessory tray 102. The circuit breaker 2, which is partially shown, includes a housing 4 (partially shown in phantom line drawing in FIG. 3), separable contacts 10 (shown in simplified form in FIG. 9) enclosed by the housing 4, and an operating mechanism 20 (shown in simplified form in FIGS. 7 and 9) structured to open and close the separable contacts 10 (FIG. 9).

The accessory assembly 100 is mountable within the housing 4, as shown in FIG. 3, and includes at least one accessory, such as the first and second primary accessories 150,150' (e.g., without limitation, shunt trip devices; undervoltage release devices) and the first and second secondary accessories 160,160' (e.g., without limitation, auxiliary switches; alarm devices), shown in FIG. 2. However, as will be discussed hereinbelow, it will be appreciated that any known or suitable type, number and configuration of accessories may be mounted on the accessory tray 102 of the accessory assembly 100, in any suitable combination other than that which is shown and described herein, without departing from the scope of the invention.

The example accessory tray 102 includes a mounting member 104 having a first side 106 (FIGS. 1 and 2) structured to receive and removably secure the accessories 150, 150', 160, 160' (all shown in FIG. 2), and a second side 108 disposed opposite the first side 106 (FIGS. 1 and 2). A guide mechanism 120, which is disposed on the second side 108 of the mounting member 104, is structured to guide the mounting member 104 into a cavity 8 of the circuit breaker housing 4. Specifically, the circuit breaker housing 4 has an exterior 6 and at least one protrusion which, in the example shown and described herein is a first guide rail 14 and a second guide rail

6

16. The guide mechanism 120 is a number of guides which, in the example shown and described herein is a pair of first and second notches 122,124, in the second side 108 of the mounting member 104. When the mounting member 104 is inserted into the cavity 8 of the circuit breaker 2, as shown in FIG. 3, the first notch 122 slidably engages the first guide rail 14 and the second notch 124 slidably engages the second guide rail 16. The guide mechanism 120 and, in particular, the interaction between the first and second guide rails 14 and 16 and the first and second notches 122 and 124, respectively, can be further appreciated with reference to FIG. 4, which illustrates the first and second guide rails 14,16 of the circuit breaker housing 4 (FIGS. 1-3) in simplified form in phantom line drawing. As shown in FIG. 4, the first and second notches 122,124 of the mounting member 104 extend between the first and second edges 110,112 of the mounting member 104. In this manner, the guide mechanism 120 functions to align the mounting member 104 with the cavity 8 (FIGS. 1-3), thereby enabling the accessories 150, 150', 160, 160' (all shown in FIG. 2) to be installed (FIG. 3) in a predetermined position within the cavity 8 (FIGS. 1-3).

As shown in FIGS. 1-3, the example circuit breaker operating mechanism 20 (shown in simplified form in FIGS. 7 and 9) includes a trip mechanism 22, and the cavity 8 is disposed beneath the trip mechanism 22. Such a location can make it difficult to see and/or access the interior of the cavity 8 in order to install (FIG. 3) the accessories 150, 150', 160, 160' (all shown in FIG. 2) therein. The disclosed accessory assembly 100, and accessory tray 102 and guide mechanism 120 therefor address and overcome this problem by slidably guiding the elongated member 104 of the accessory tray 102 into and out of the predetermined position within the cavity 8, in order to accurately install the accessories 150, 150', 160, 160' (FIG. 2) therein, as previously discussed.

Referring again to FIG. 4, the example accessory tray 102 further includes a number of lateral protrusions 126,128 extending laterally outwardly from the first edge 110 of the mounting member 104. These lateral protrusions 126,128 further facilitate the accurate installation of the accessories 150, 150', 160, 160' (only primary accessory 150' is shown in FIG. 4) by engaging corresponding openings 32,34 of a side plate 30 (partially shown in phantom line drawing in FIG. 4) of the circuit breaker 2. Specifically, the side plate 30 includes a first opening 32 and a second opening 34. When the accessory tray 102 is installed within the circuit breaker cavity 8, as shown in FIG. 3, the first lateral protrusion 126 engages the first opening 32 of side plate 30, and the second lateral protrusion 128 engages the second opening 34 of the side plate 30, as shown in simplified form in FIG. 4.

Continuing to refer to FIGS. 1-4, and also to FIGS. 5A and 6, it will be appreciated that the mounting member 104 further includes a first end 114, a second end 116 disposed opposite and distal from the first end 114, a generally planar portion 118 extending from at or about the second end 116 toward the first end 114, and at least one mounting portion 130,132. As will be discussed hereinbelow, the example mounting member 104 includes a first mounting portion 130 and a second mounting portion 132, which are respectively structured to receive and secure the aforementioned primary accessories 150,150' and secondary accessories 160,160', preferably without requiring the use of a number of separate fasteners. It will also be appreciated that the example accessories 150, 150', 160, 160' (all shown in FIG. 2) are preferably removable from their corresponding mounting portions 130,132, without requiring use of a number of separate tools.

The first mounting portion 130 will now be described with reference to FIG. 5A, which shows an accessory module 200'

being removably mounted on the mounting member 104 of the accessory tray 102. For economy of disclosure, the first mounting portion 130 will only be described with respect to removably securing mounting module 200', although it will be appreciated that the other accessory module 200 (FIGS. 2, 6 and 7) is mounted to the mounting member 104 in a substantially identical manner. Specifically, the first mounting portion 130 includes a first connection mechanism 134' (see also first connection mechanism 134) disposed on the generally planar intermediate portion 118 of the mounting member 104, and a second connection mechanism 136' (see also second connection mechanism 136) disposed proximate the second end 116 of the mounting member 104. Thus, the first mounting portion 130 of the example accessory tray 102 extends longitudinally from the second end 116 of the mounting member 104 toward the first end 114 thereof. The first connection mechanism 134 is structured to receive and secure one end 152' of the enclosure 151' of a corresponding one of the primary accessories 150', and the second connection mechanism 136 is structured to releasably secure the other end 154' of the accessory 150' (best shown in FIG. 5B). The second mounting portion 132, which will be discussed in greater detail hereinbelow, is disposed at or about the first end 114 of the mounting member 104, and extends perpendicularly with respect to the first mounting portion 130.

The example first connection mechanism 134' is a molded receptacle 142' (see also molded receptacle 142) extending outwardly from the generally planar intermediate portion 118 of the mounting member 104. The example second connection mechanism 136' is a resilient tab 144' (see also resilient tab 144) extending outwardly from the mounting member 104 proximate the second end 116 thereof. The first end 152' of the enclosure 151' of the accessory module 200' includes a first protrusion 202' (see also protrusion 202 of the first end 152 of the enclosure 151 of accessory module 200 of FIGS. 2, 6 and 7) extending outwardly therefrom, and the second end 154' of the enclosure 151' includes a second protrusion 204' (see also second protrusion 204 of the second end 154 of the enclosure 151 of accessory module 200 of FIG. 2) extending outwardly therefrom. These protrusions 202', 204' enable the example accessory module 200' to be installed in a "toe-heel" fashion, in which the first protrusion 202' is first inserted into the molded receptacle 142' and is then rotated (e.g., clockwise with respect to FIG. 5A), as shown, until the second protrusion 204' is releasably secured by the resilient tab 144', as shown in FIG. 5B. In other words, the resilient tab 144' is movable between a first position (FIG. 5A) corresponding to the accessory module 200' not being on the mounting member 104, and a second position (FIG. 5B) corresponding to the accessory module 200' being installed on the mounting member 104. When the accessory module 200' is installed on the mounting member 104, the resilient tab 144' is biased against the second protrusion 204', thereby securing the accessory module 200' on the mounting member 104. If it is subsequently desired to remove the accessory module 200', the resilient tab 144' can simply be deflected (e.g., to the right with respect to FIG. 5B) to release the second protrusion 204'. As previously discussed, this operation can be performed without requiring the use of a number of separate tools (e.g., it can be performed by hand).

As shown in FIGS. 5A and 5B, the example resilient tab 144' includes a retention portion 145' (see also retention portion 145 of resilient tab 144 of FIG. 5A). When the accessory module 200' is installed on the mounting member 104, the retention portion 145' overlays the second protrusion 204', as shown in FIG. 5B, in order to further resist the accessory module 200' from being undesirably removed. The example

mounting member 104 further includes at least one molded cavity 186' (see also molded cavity 186 of FIG. 5A), which is disposed at or about the second 116 thereof. The resilient tab 144' is disposed within the molded cavity 186' and, when the accessory module 200' is installed on the mounting member 104, as shown in FIG. 5B, the second protrusion 204' of the second end 154' of the enclosure 151' of the accessory module 200' extends into the molded cavity 186' and is secured therein by the resilient tab 144'.

The generally planar intermediate portion 118 of the mounting member 104 of the example accessory tray 102 further includes a number of locating protrusions 188, 190, and the accessory modules (e.g., accessory module 200' of FIG. 5A) include a number of corresponding recesses 206, 208. Thus, when the accessory module 200' is installed (FIG. 5B) on the mounting member 104, a corresponding pair of the locating protrusions 188, 190 is structured to be disposed within the corresponding recess 206, 208, respectively, of the enclosure 151' of the accessory module 200'. In this manner, the example accessory modules 200, 200' (both shown in FIG. 6) are aligned and maintained in a predetermined position on the mounting member 104.

The example second mounting portion 132 for receiving the aforementioned secondary accessories 160, 160' (FIGS. 2, 6 and 7) includes two molded compartments 138, 138' (FIGS. 1, 2, 5A, 6 and 7) disposed between the first and second edges 110, 112 of mounting member 104, at or about the first end 114 of the mounting member 104. Each molded compartment 138, 138' includes a resilient protrusion 140, 140', which extends outwardly from the mounting member 104 and is structured to bias against a corresponding one of the secondary accessories 160, 160' when it is disposed within the molded compartment 138, 138' as shown in FIGS. 2, 6 and 7. In this manner, the secondary accessories 160, 160' are maintained in a predetermined position with respect to the mounting member 104 of the accessory tray 102. It will be appreciated that although two molded compartments 138, 138', for receiving two corresponding secondary accessories 160, 160', are shown and described herein, that any known or suitable alternative number and configuration of suitable mounting mechanisms (not shown) could be employed to secure any suitable number of secondary accessories (e.g., without limitation, the alarm mechanisms 160, 160' shown in FIGS. 2, 6 and 7) on the mounting member 104, without departing from the scope of the invention. The example alarm mechanisms 160, 160' (e.g., without limitation, bell alarms) each include a lever 161, 161' (lever 161 is only partially shown in FIG. 7; see also FIGS. 2 and 6) which is structured to be moved in response to a trip condition of the circuit breaker 2; see also the arm shown in phantom line drawing in simplified form which is coupled to the trip bar 24 in FIG. 7).

The example mounting member is preferably a single-piece molded member 104, with the first and second mounting portions 130, 132, guide mechanism 120, and first and second connection mechanisms 134, 136 being molded segments of the single-piece molded member 104. Additionally, the first and second ends 114, 116 of the mounting member 104 of the example accessory tray 102 further include first and second stops 146, 148 disposed on the first and second ends 114, 116, respectively, at or about the second edge 112 of the mounting member 104, as shown in FIGS. 1-4, 5A and 6. The stops 146, 148 function to further properly orient the accessory tray 102 within (FIG. 3) the circuit breaker cavity 8. Specifically, when the accessory tray 102 is fully inserted within the cavity 8, as shown in FIG. 3, the first stop 146 is disposed at or about a first portion 17 of the circuit breaker housing 4, and the second stop 148 is disposed at or about a

second portion **18** of the housing **4**. The first and second portions are vertical members **17,18** of the example circuit breaker **2**, which define the first and second ends **9,11**, respectively, of the cavity **8** beneath the trip mechanism **22**, as shown in FIGS. **1-3**.

FIGS. **6, 7, 8A** and **8B** show a strain relief mechanism **300,300'** (strain relief mechanism **300'** is only shown in FIGS. **6** and **7**) for the corresponding accessory module **200,200'**. For economy of disclosure, only one strain relief mechanism **300** for the first accessory module **200** will be described in detail. It will, however, be appreciated that the strain relief mechanism **300'** of the second accessory module **200'** is substantially identical. Specifically, the first end **152** of the enclosure **151** of the accessory module **200** includes an aperture **156** (shown in hidden line drawing in FIG. **8A**) and a number of electrical conductors **158** extending therethrough, and outwardly from the first end **152** of the enclosure **151**. It will be appreciated that while the electrical conductors **158** which may comprise, for example and without limitation, electrical wires, extend outwardly with respect to the first end **152** of the enclosure **151**, that such electrical conductors could be either input conductors (e.g., heading into the enclosure **151**), or output conductors (e.g., leading out of the enclosure **151**). In either case, it is desirable to secure the electrical conductors **158** in order to resist undesired movement thereof with respect to the enclosure **151** and the aperture **156** thereof. To accomplish this objective, the disclosed strain relief mechanism **300** includes a support **302**, which is structured to extend outwardly from the first end **152** of the enclosure **151** and to be proximate the aperture **156** (shown in hidden line drawing in FIG. **8A**) and electrical conductors **158** extending therethrough. A fastening mechanism **320** such as, for example and without limitation, the wire tie **322**, which is shown, secures the electrical conductors **158** to the support **302**.

More specifically, as shown in FIGS. **6, 7** and **8B**, the example support **302** is a post **304** having a first end **306** disposed at or about the first end **152** of the enclosure **151**, a second end **308** disposed opposite and distal from the first end **306**, and a shank **310** extending between the first and second ends **306,308**. The wire tie **322** (partially shown in section view in FIG. **8B**) wraps around the electrical conductors **158** and the support **302**, and is fastened in order to secure the electrical conductors **158** thereto, as best shown in FIGS. **8A** and **8B**. The second end **308** of the post **304** includes an enlarged head **312**, which extends laterally outwardly from the post **304** in order to retain the wire tie **322** on the shank **310** of the post **304** (best shown in FIGS. **8A** and **8B**). It will be appreciated that any known or suitable alternative elongated fastening mechanism (not shown) other than the exemplary wire tie **322** could be employed to perform this securing function. It will also be appreciated that any combination of wire ties **322** or other suitable fastening mechanisms (not shown) could be employed to secure the electrical conductors **158,158'** of the accessory modules **200,200'** to the strain relief mechanisms **300,300'** (both shown in FIGS. **6** and **7**) thereof. For example, one wire tie **322** is shown for strain relief mechanism **300'** in FIGS. **6** and **7**.

The enclosure **151** of the example accessory module **200** includes a first portion **162** and a second portion **164**, which is structured to be coupled to the first portion **162** in order to enclose the accessory **150** (shown in simplified form in FIG. **8B**) therebetween, as shown in FIG. **8B**. The post **304** of the example strain relief mechanism **300** further includes a first side **314** extending outwardly from the first portion **162**, and a second side **316** extending outwardly from the second portion **164**. Accordingly, the fastening mechanism **320** not only

fastens the electrical conductors **158** to the post **304**, but also fastens the first side **314** of the post **304** to the second side **316** of the post **304**, thereby fastening the first and second portions **162,164** of the enclosure **151** of the accessory module **200**. In the example shown and described herein, the first portion **162** of the enclosure **151** and the first side **314** of the post **304** are a first single-piece molded member, and the second portion **164** of the enclosure **151** and the second side **316** of the post **304** are a second single-piece molded member **164**.

The first single-piece molded member **162** includes at least one molded protrusion **170,172** (first and second molded protrusions **170,172** are shown in FIG. **8A**, with the second molded protrusion **172** being shown in hidden line drawing), and the second single-piece molded member **164** includes at least one receptacle **174,176** (two molded receptacles **174,176** are shown in FIG. **8A**, with the second receptacle being shown in hidden line drawing). Each receptacle **174,176** receives a corresponding one of the molded protrusions **170,172** in order to fasten the first and second portions **162,164** of the enclosure **151** together, as shown in FIG. **8A**, without requiring the use of a plurality of separate fasteners. The example first portion **162** includes a first side **166** and a second side **167**, and the second portion **164** includes a first side **168** and a second side **169**. The first resilient tab **170** extends outwardly from the first side **166** of the first portion **162** and is received by a corresponding first molded receptacle **174** on the first side **168** of the second portion **164**. Similarly, the second resilient tab **172** extends outwardly from the second side **167** of the first portion **162** and is received by a corresponding second molded receptacle **176** on the second side **169** of the second portion **164**, as shown in hidden line drawing in FIG. **8A**. In this manner, the first and second portions **162,164** of the enclosure **151** of the accessory module **200** are secured together. It will be appreciated that the second accessory module **200'** (FIGS. **2-4, 5A, 5B, 6** and **7**) is secured together in substantially the same manner.

As shown in FIG. **8A**, the enclosure **151** of the example accessory module **200** further includes a first side **178**, a second side **180**, and first and second opposing edges **182,184**. As best shown in FIG. **8A**, the aperture **156** (shown in hidden line drawing) of the enclosure **151**, the electrical conductors **158**, and the strain relief mechanism **300** are disposed closer to the first side **178** of the enclosure **151** than the second side **180**, and closer to the first edge **182** of the enclosure **151** than the second edge **184**. It will, however, be appreciated that any suitable alternative configuration of these features (e.g., aperture **156**; electrical conductors **158**; strain relief mechanism **300**) other than that which is shown and described herein, could be employed without departing from the scope of the invention. It will also be appreciated that the second accessory module **200'** (FIGS. **2-4, 5A, 5B, 6** and **7**) in the example accessory assembly **100**, has a substantially identical structure as does the first accessory module **200**, but is not numbered or discussed independently in its entirety, for economy of disclosure.

In addition to avoiding undesired strain on the electrical conductors **158**, it is also desirable to position the electrical conductors **158** in a manner which will not undesirably interfere with the operation of the accessories (e.g., without limitation, primary accessories **150,150'** and secondary accessories **160,160'** of FIGS. **2, 6** and **7**) or other components (e.g., without limitation, operating mechanism **20** (FIG. **9**); trip bar **24** (FIG. **7**)) of the circuit breaker **2** (FIGS. **1-4, 7, 9** and **10**). To accomplish this objective, the example accessory module **200** further includes an electrical conductor mount **400,400'**, shown in FIGS. **2, 4** (showing electrical conductor mount **400'**), **5A** (showing electrical conductor mount **400'**), **6, 7**

(showing electrical conductor mounts **400,400'**) and **8A-8B** (showing electrical conductor mount **400**). For economy of disclosure, only one electrical conductor mount **400** for accessory module **200** will be discussed. It will, however, be appreciated that the electrical conductor mount **400'** for the second accessory module **200'** (FIGS. **2-4, 5A, 5B, 6** and **7**) is substantially identical to the electrical conductor mount **400** of first accessory module **200**. Specifically, the accessory **150** further includes an actuator which, in the example shown and described herein is an actuator **159** (e.g., without limitation, a stem), that extends through a second aperture **157** of the first end **152** of the enclosure **151** of the accessory module **200**, as best shown in FIGS. **6** and **8A**. The electrical conductor mount **400** includes a mounting element **402**, which is structured to be disposed on the enclosure **151** and to be proximate the electrical conductors **158** external to the enclosure **151**. The mounting element **402** includes a receiving portion **404** structured to receive the electrical conductors **158**, and a retaining portion **406** (not fully shown in FIG. **8B**) structured to retain the electrical conductors **158** within the receiving portion **404**. In this manner, the mounting element **402** mounts the electrical conductors **158** in a position (e.g., without limitation, above the accessory actuator **159**), which may be predetermined, and in which the electrical conductors **158** do not obstruct operation of the actuator **159**.

The example mounting element **402** is a resilient hook **408** having a first end **412** disposed on the enclosure **151**, and a second end **414**. It will be appreciated, however, that the mounting element **402** may comprise any known or suitable resilient element other than the example resilient hook **408**, without departing from the scope of the invention. The retaining portion **406** (not fully shown in FIG. **8B**) of the example resilient hook **408**, is a hook or molded barb **410** (not shown in FIG. **8B**) disposed at or about the second end **414** of the resilient hook **408**. The receiving portion **404** extends outwardly from the enclosure **151** and turns and extends generally parallel with respect to the enclosure **151** in order to form an opening **416** between the mounting element **402** and the enclosure **151**. The retaining portion **406** extends from the receiving portion **404** toward the enclosure **151**. The resilient element **402** is deflectable among a first position corresponding to the retaining portion **406** being disposed at or about the enclosure **151**, and a second position (not expressly shown) corresponding to the retaining portion **406** being deflectable away from the enclosure **151** in order to receive the electrical conductors **158** within opening **416** of the receiving portion **404**. Accordingly, when the electrical conductors **158** are disposed within the receiving portion **404**, the resilient element **402** biases the electrical conductors **158** toward the enclosure **151**, as shown in FIG. **8A**, in order to maintain them in the desired position. The example resilient hook **408** is a single-piece molded member **402**.

Accordingly, it will be appreciated that the example accessory module **200** includes first and second apertures **156,157** (shown in hidden line drawing in FIG. **8A**) disposed on the first end **152** of the enclosure **151**. The electrical conductors **158** extend through the first aperture **156**, and the actuator **159** (e.g., without limitation, stem) extends through the second aperture **157**. Thus, in order to maintain the electrical conductors **158** in the position which does not interfere with the actuator **159**, the example electrical conductor mount **400** is disposed above (with respect to FIGS. **6, 7** and **8A**) the second aperture **157** and actuator **159** extending therethrough. More specifically, as previously discussed, the first aperture **156** (shown in hidden line drawing in FIG. **8A**) is disposed closer to the first side **178** of the enclosure **151** of the accessory module **200** than the second side **180** thereof, and closer to the

first edge **182** of the enclosure **151**, than the second edge **184** thereof. The mounting element **402** extends outwardly from the first end **152** of the enclosure **151** beside the first aperture **156** (shown in hidden line drawing in FIG. **8A**) and the electrical conductors **158** extending therethrough, and further extends above (with respect to FIGS. **6, 7** and **8A**) the second aperture **157** and the actuator **159**. The electrical conductors **158** thus extend generally laterally from the first aperture **156** (FIG. **8A**) through the receiving portion **404** of the mounting element **402**, and toward the second edge **184** of the enclosure **151**, in order that electrical conductors **158** are maintained in a position which is above (with respect to FIGS. **6, 7** and **8A**) and spaced from the actuator **159**. It will, therefore, be appreciated that the example second aperture **157** and actuator **159** are disposed closer to the second side **180** of the enclosure **151** than the first side **178** of the enclosure **151**.

As shown in FIGS. **6** and **7**, the example conductor mount **400** is structured to receive, for example and without limitation, two or four electrical conductors **158,158'**, and maintain them in the desired position. Specifically, when the accessory modules **200,200'** of the first and second primary accessories **150,150'** are disposed on the accessory tray **102** adjacent one another, as shown, the electrical conductor amount **400** of the first accessory module **200** secures the electrical conductors **158** of the first primary accessory **150**, and the electrical conductor mount **400'** of the second accessory module **200'** secures both the electrical conductors **158** of the first primary accessory **150** and the electrical conductors **158'** of the second primary accessory **150'**, as shown. Thus, it will be appreciated that the opening **416** of the receiving portion **406** of the resilient element **402** is capable of receiving, for example and without limitation, at least four electrical conductors **158,158'** (e.g., electrical wires) and securing them in the desired position, which does not interfere with the operation of the actuators **159** and **159'** of the accessory modules **200** and **200'**, respectively. As previously discussed, the example actuators **159,159'** are stems. The stems **159,159'** move inwardly and outwardly with respect to their corresponding enclosure **151, 151'** to engage (FIG. **13B**) a paddle **26** (FIG. **7**) of the trip bar **24** (FIG. **7**) of the circuit breaker **2**, in order to, for example, move (e.g., pivot) the trip bar **24** and initiate a trip of the circuit breaker **2** in response to a trip condition.

As shown in FIGS. **3, 9, 10, 11, 12A** and **12B**, the circuit breaker **2** further includes a sub-assembly **500** (shown in phantom line drawing in FIG. **3**) having a plurality of auxiliary switches **504** (shown in phantom line drawing in FIG. **3**; two auxiliary switches **504** are shown in FIGS. **11** and **12B**; one auxiliary switch **504** is shown in FIG. **12A**). The auxiliary switches **504** are cooperable with an actuating mechanism of the circuit breaker **2** (FIGS. **3, 9** and **10**) which, in the example shown and described herein, is an auxiliary paddle **28** (FIGS. **3, 9, 10** and **12A**). Specifically, the sub-assembly **500** includes an auxiliary switch tray **502** having a module **506** with first and second sides **508,510**, and a plurality of mounts **520** disposed on the first side **508**. Each mount **520** is structured to receive a corresponding one of the auxiliary switches **504**. The auxiliary switch tray **502** also includes a base **540** disposed on the second side **510** of the module **506**, and structured to be removably coupled to a mounting mechanism **12,13** (FIGS. **3, 9** and **10**) of the circuit breaker **2** (FIGS. **3, 9** and **10**). As will be discussed, the example mounting mechanism is a pair of opposing first and second guide rails **12,13** disposed on the circuit breaker housing **4** proximate the side plate **30** of the circuit breaker **2**, as shown in FIGS. **3, 9** and **10**. In this manner, the auxiliary switch tray **502** is structured to install the auxiliary switches **504** in a predetermined position with respect to the auxiliary paddle **28** of the circuit breaker **2**,

as shown in FIG. 10. In this manner, the auxiliary paddle 28 can activate the actuators (e.g., without limitation, levers 560) of the auxiliary switches 504, for example, in response to an opened or closed position of the separable contacts 10 (FIG. 9) of the circuit breaker 2. Specifically, the example auxiliary paddle 28 is cooperable with the pole shaft 21 (partially shown in FIGS. 9 and 10) of the circuit breaker operating mechanism 20 (FIG. 9) in order that the pole shaft moves (e.g., pivots) the auxiliary paddle 28 into engagement (shown in phantom line drawing in FIG. 10A) with the auxiliary switch actuators 560 when the pole shaft 21 rotates, for example, in response to the open or closed position. In this manner, the auxiliary switches can be employed to relay signals indicative of the status (e.g., opened, closed) of the circuit breaker 2, as desired.

As best shown in FIGS. 11, 12A and 12B, the example mounts 520 are molded compartments of the module 506. Each molded compartment 520 is structured to receive a corresponding one of the auxiliary switches 504, and to removably secure the auxiliary switch 504 to the module 506, without requiring the use of a number of separate fasteners. For economy of disclosure, only one molded compartment 520 will be discussed in detail. It will, however, be appreciated that the other molded compartments 520 of the module 506 of the auxiliary switch tray 502 are substantially identical. It will also be appreciated that although the example sub-assembly 500 and auxiliary switch tray 502 thereof shown and described herein include four molded compartments 520 for securing four corresponding auxiliary switches 504, that the module 506 of the auxiliary switch tray 502 could alternatively include any suitable number and configuration (not shown) of molded compartments 520 for securing any known or suitable accessory (e.g., without limitation, micro switches), without departing from the scope of the invention.

Each of the example molded compartments 520 includes a first resilient tab 522 (FIGS. 11 and 12B) and a second resilient tab 524 (not shown in FIG. 12B). The first resilient tab 522 (FIGS. 11 and 12B) includes a retaining portion 526 (FIGS. 11 and 12B) which is deflectable in order to receive the corresponding auxiliary switch 504 (see, for example, auxiliary switch 504 being installed in molded compartment 502 in FIG. 11). When the auxiliary switch 504 is disposed within the molded compartment 520, the retaining portion 526' (see also retaining portion 526 of FIG. 12B) retains the auxiliary switch 504 therein, and the second resilient tab 524 biases the auxiliary switch 504 into a desired orientation within the molded compartment 520, as shown in FIG. 12A. More specifically, the molded compartment 520 further includes a first end 528 (not shown in FIG. 12B), a second end 530 (not shown in FIG. 12B) disposed opposite and distal from the first end 528, a first side 532 (not shown in FIG. 12A) and a second side 534 (not shown in FIG. 12A) disposed opposite and spaced apart from the first side 532 of the molded compartment 520.

Each of the example auxiliary switches 504 includes a first end 550 (not shown in FIG. 12B), a second end 552 disposed opposite and distal from the first end 550, and first and second opposing sides 554, 556. The aforementioned first resilient tab 522 is disposed on the first side 532 of the molded compartment 520. The example retaining portion 526 is a molded hook extending from at or about the first side 532 of the molded compartment 520 toward the second side 534 thereof. The example second resilient tab 524 extends from the first end 528 of the molded compartment 520 toward the second end 530, as shown in FIGS. 11 and 12A. Accordingly, when the auxiliary switch 504 is disposed in the molded compart-

ment 520, the molded hook 526 of the first resilient tab 522 overlays the second side 556 of the auxiliary switch 504, as shown in FIG. 12B, and the second resilient tab 524 engages the first end 550 of the auxiliary switch 504 and biases the auxiliary switch 504 towards the second end 530 of the molded compartment 520, as shown in FIG. 12A, in order that the terminals 562, 564 are disposed through access hole 531.

Continuing to refer to FIGS. 12A and 12B, the example auxiliary switch 504 further includes a switch 558 disposed on the first side 554 of the auxiliary switch 504, a lever 560 (FIG. 12A) extending from the first end 550 of the auxiliary switch 504 and being cooperable with the switch 558, and a number of terminals 562, 564 (two are shown) (e.g., without limitation, common; normally open; normally closed) disposed on the second end 552 of the auxiliary switch 504. The first end 528 of the example molded compartment 520 includes an opening 529 structured to receive the lever 560, and the second end 530 of the molded compartment 520 includes an access hole 531 for providing access to the terminals 562, 564 of the auxiliary switch 504 when it is properly disposed within the compartment 520, as shown in FIG. 12A. Additionally, the first side 532 of the molded compartment 520 includes a molded recess 533 for receiving the switch 558. In this manner, the auxiliary switch tray 502 provides an improved mechanism for precisely positioning and installing auxiliary switches 504 within the circuit breaker 2 (FIGS. 3, 9 and 10), wherein the auxiliary switches which, in the example shown and described herein are stock (e.g., unaltered; devoid of a separate mounting housing or custom bracket) micro-switches 504 and are removably mountable in a predetermined position, without requiring the use of a number of separate fasteners. In this manner, the auxiliary switches 504 and, in particular, the levers 560 thereof, can be actuable by the circuit breaker auxiliary paddle 28 to depress the switch 558 of the auxiliary switch 504, as shown in phantom line drawing in FIG. 12A, in order to relay the desired signal regarding the operational state (e.g., without limitation, opened; closed) state of the circuit breaker 2 (FIGS. 3, 9 and 10) as previously discussed.

To further facilitate the accurate placement of the sub-assembly 500 within (FIGS. 3 (phantom line drawing) and 10) the circuit breaker 2 (FIGS. 3, 9 and 10), the example module 506 further includes first and second lateral protrusions 542, 544 which respectively extend outwardly from the first and second edges 512, 514 at or about the second side 510 of the module 506. Accordingly, when the module 506 is inserted into the circuit breaker 2, the first lateral protrusion 542 of the base 540 engages the first mounting rail 12 and the second lateral protrusion 544 of the base 540 of the module 506 engages the second mounting rail 13, in order to align the module 506 with respect to the circuit breaker 2, as shown in FIG. 9, and to install the auxiliary switches 504 in the predetermined position with respect to the auxiliary paddle 28 therein, as shown in FIGS. 3 (shown in phantom line drawing) and 10.

Accordingly, referring again to FIG. 11, it will be appreciated that the disclosed auxiliary switch tray 502 enables a plurality of micro-switches 504 (four example micro-switches 504 are shown) to be removably secured adjacent one another in the module 506 of the auxiliary switch tray 502, with the first resilient tabs 522, 522' and retaining portions 526, 526' thereof functioning to secure the micro-switches 504 within the corresponding molded compartments 520, and second resilient protrusions 524, 524' functioning to bias the micro-switches 504 into the desired predetermined position within the corresponding compartment 520, as shown. In this manner, the levers 560 of the

15

micro-switches 504 are relatively quickly and easily, precisely positioned with respect to the auxiliary paddle 28 of the circuit breaker operating mechanism 20 (shown in simplified form in FIG. 9), with all of the levers 560 of the micro-switches 504 being actuatable by the auxiliary paddle 28, as previously discussed. The disclosed sub-assembly 500 and auxiliary switch tray 502 therefor, thus greatly simplify the installation of accessories (e.g., without limitation, micro-switches 504), within the circuit breaker 2.

As shown in FIGS. 7, 13A and 13B, the trip bar 24 of the circuit breaker 2 (FIGS. 7 and 13B) includes an elongated pivot member 40 having a length 41 (FIG. 7), a first end 42, and a second end 44. The first end 42 is pivotably coupled to the circuit breaker operating mechanism 20 (shown in simplified form in phantom line drawing in FIG. 7). The second end 44 includes a deflecting mechanism 50, which is structured to deflect the actuator 159 (e.g., without limitation, stem) of the primary accessory 150, as shown in FIG. 13A, in order to facilitate insertion of the primary accessory 150 (see also primary accessory 150' of FIG. 7) into the circuit breaker housing 4 (FIG. 7). More specifically, the elongated pivot member 40 of the trip bar 24 includes at least one protrusion such as, for example and without limitation, a number of auxiliary paddles 46 (one auxiliary paddle 46 is shown), which extend outwardly from the elongated pivot member 40 between the first and second ends 42,44 (first end 42 is not shown in FIG. 13B) thereof. The auxiliary paddle 46 is structured to be actuated by the actuator 159 of the accessory 150 when the actuator 159 extends to position shown in FIG. 13B, for example, in response to a trip condition as determined by the primary accessories 150,150' (FIGS. 7 and 13B). At least one of the example primary accessories 150,150' (both shown in FIG. 7) is an under voltage release (UVR) device, and the example actuators 159,159' (both shown in FIG. 7) of the primary accessories 150,150' are stems 159,159'. Each stem 159,159' is movable between the first position of FIG. 7, in which the stem 159,159' is retracted (e.g., the UVR device is energized by a sufficient voltage) and does not actuate the auxiliary paddle 46 of the elongated pivot member 40, and the second (e.g., extended) position of FIG. 13B, in which the stem 159 actuates (e.g., moves) the auxiliary paddle 46, as previously discussed, and thereby pivots (e.g., clockwise with respect to FIG. 13B) the elongated pivot member 40 of the trip bar 24.

As shown in FIG. 13A, before the UVR device 150 is installed within the circuit breaker housing 4 (FIG. 7), the stem 159 is disposed in the second (e.g., extended) position, corresponding to the UVR device 150 being in a non-energized state, for example, before the aforementioned accessory assembly 100 (FIGS. 1-4, 5A, 5B, 6 and 7) and the accessories 150, 150', 160, 160' (all shown in FIGS. 6 and 7) thereof are installed within the circuit breaker housing 4 (FIG. 7). Then, as the UVR device 150 is being installed, the deflecting mechanism, which in the example shown and described herein is a cam surface 50, is increasingly deflected by the stem 159 of the UVR device 150 in order to pivot the trip bar 24 out of the way of the stem 159. It will, however, be appreciated that the stem 159 could alternatively be deflected by the cam surface 50 from the extended position toward the retracted position. In this manner, the UVR device 150 can be relatively easily and quickly inserted, for example, without requiring the stem 159 to be held in the retracted position (FIG. 7) by hand. Once the UVR device 150 is fully installed within the circuit breaker 2, as shown in FIG. 7, and is electrically connected and suitably energized, the UVR device

16

150 thereby holds the stem 159 in the retracted position until a trip condition (e.g., without limitation, under voltage) is detected thereby.

The example trip bar 24 is a single-piece molded member, which extends outwardly from the side plate 30 of the circuit breaker 2, as best shown in FIG. 7, and includes a single elongated auxiliary paddle 46. The example single elongated auxiliary paddle 46 extends from at or about the second end 44 of the elongated member 40 of the trip bar 24 toward the first end 42 thereof, and includes a first side 48, which is actuatable by the stem 159 of the UVR device 150, as previously discussed, and a second side 49 disposed opposite the first side 48. The example cam surface 50 includes a first end 52 disposed on the second end 44 of the elongated pivot member 40 of the trip bar 24, a second end 54 disposed on the first side 48 of the single elongated auxiliary paddle 46, and a tapered portion 56 that extends from the first end 52 toward the second end 54. It will, however, be appreciated that any known or suitable alternative deflecting mechanism (not shown) and/or number and configuration of auxiliary paddles (not shown) could be employed to suitably deflect and cooperate with the accessory stem 159, without departing from the scope of the invention.

As shown in FIG. 13B, the elongated pivot member 40 of the example trip bar 24 further includes a tab 62, which extends outwardly from the elongated pivot member 40. The example trip bar 24 and the single elongated auxiliary paddle 46 thereof, are biased (e.g., counterclockwise with respect to FIG. 13B) toward engagement with the stem 159 by a suitable bias element such as, for example and without limitation, a spring (not shown). In this manner, the trip bar 24 is continuously biased into a position in which it is ready to be actuated by the accessory stems 159,159', for example, in response to a trip condition of the circuit breaker 2.

Accordingly, the disclosed trip bar 24 facilitates insertion of primary accessories such as, for example and without limitation, UVR device (e.g., 150), which include an actuator 159 (e.g., without limitation, stem) that would otherwise interfere with the trip bar 24 during installation of the accessory 150 within the circuit breaker 2 (FIGS. 3 and 7). Thus, the primary accessories 150,150' can be relatively easily and quickly installed within the circuit breaker 2, without having to hold the actuators 159,159' of the accessories in their respective retracted positions. It will be appreciated that the primary accessories 150,150' can be installed with the stems 159,159' thereof being disposed in any suitable position. For example, both stems 159,159' could be extended. It will also be appreciated that the primary accessory 150 and/or primary accessory 150' could be, for example and without limitation, a shunt trip device or other suitable accessory that may be readily installed with a retracted stem (e.g., 159,159').

While specific embodiments of the invention have been described in detail, it will be appreciated by those skilled in the art that various modifications and alternatives to those details could be developed in light of the overall teachings of the disclosure. Accordingly, the particular arrangements disclosed are meant to be illustrative only and not limiting as to the scope of the invention which is to be given the full breadth of the claims appended and any and all equivalents thereof.

What is claimed is:

1. An auxiliary switch tray for an electrical switching apparatus including a housing, an actuating mechanism, and a plurality of auxiliary switches, said housing having a mounting mechanism, said auxiliary switch tray, comprising:
 - a module including a first side and a second side disposed opposite the first side;

17

a plurality of mounts disposed on the first side, at least a plurality of said mounts being structured to receive a corresponding one of said auxiliary switches;

a base disposed on the second side of said module, said base being structured to be coupled to said mounting mechanism in order to install said auxiliary switches in a predetermined position with respect to said actuating mechanism of said electrical switching apparatus;

wherein said at least a plurality of said mounts is structured to removably secure said corresponding one of said auxiliary switches to said module without a number of separate fasteners;

wherein each of said at least a plurality of said mounts is a compartment structured to receive said corresponding one of said auxiliary switches;

wherein said compartment comprises a first resilient tab and a second resilient tab; wherein said first resilient tab includes a retaining portion structured to retain said corresponding one of said auxiliary switches within said compartment; and

wherein said second resilient tab is structured to bias said corresponding one of said auxiliary switches into a desired orientation within said compartment.

2. The auxiliary switch tray of claim 1 wherein said compartment further comprises a first end, a second end disposed opposite and distal from the first end, a first side, and a second side disposed opposite and spaced apart from said first side of said compartment; wherein said first resilient tab is disposed on the first side of said compartment; wherein said retaining portion of said first resilient tab is a molded hook extending from at or about the first side of said compartment toward the second side of said compartment; and wherein said second resilient tab extends from the first end of said compartment toward the second end of said compartment.

3. An auxiliary switch tray for an electrical switching apparatus including a housing, an actuating mechanism, and a plurality of auxiliary switches, said housing having a mounting mechanism, said auxiliary switch tray, comprising:

a module including a first side and a second side disposed opposite the first side;

a plurality of mounts disposed on the first side, at least a plurality of said mounts being structured to receive a corresponding one of said auxiliary switches;

a base disposed on the second side of said module, said base being structured to be coupled to said mounting mechanism in order to install said auxiliary switches in a predetermined position with respect to said actuating mechanism of said electrical switching apparatus; and

wherein said mounting mechanism of said electrical switching apparatus includes a first portion and a second portion; wherein said module further includes a first edge and a second edge disposed opposite and distal from the first edge of said module; wherein said base comprises a first lateral protrusion extending outwardly from the first edge of said module at or about the second side of said module, and a second lateral protrusion extending outwardly from the second edge of said module at or about the second side of said module; wherein said module is structured to be removably insertable into said electrical switching apparatus; and wherein, when said module is inserted into said electrical switching apparatus, said first lateral protrusion of said base of said module is structured to engage said first portion and said second lateral protrusion of said base of said module is structured to engage said second portion in order to align

18

said module with respect to said electrical switching apparatus and to install said auxiliary switches in said predetermined position.

4. A sub-assembly for an electrical switching apparatus including a housing having a mounting mechanism, and an actuating mechanism, said sub-assembly, comprising:

a plurality of auxiliary switches;

an auxiliary switch tray comprising:

a module including a first side and a second side disposed opposite the first side;

a plurality of mounts disposed on the first side of said module, at least a plurality of said mounts receiving a corresponding one of said auxiliary switches;

a base disposed on the second side of said module and being removably coupled to said mounting mechanism, in order to install said auxiliary switches in a predetermined position with respect to said actuating mechanism of said electrical switching apparatus;

wherein each of said at least a plurality of said mounts is a molded compartment of said module; and wherein said molded compartment receives said corresponding one of said auxiliary switches and removably secures said corresponding one of said auxiliary switches to said module without a number of separate fasteners; and

wherein said molded compartment comprises a first resilient tab and a second resilient tab; wherein said first resilient tab includes a retaining portion; wherein said retaining portion of said first resilient tab is deflectable in order to receive said corresponding one of said auxiliary switches within said molded compartment; and wherein, when said corresponding one of said auxiliary switches is disposed within said molded compartment, said retaining portion retains said corresponding one of said auxiliary switches within said molded compartment, and said second resilient tab biases said corresponding one of said auxiliary switches into a desired orientation within said molded compartment.

5. The sub-assembly of claim 4 wherein said molded compartment further comprises a first end, a second end disposed opposite and distal from the first end, a first side and a second side disposed opposite and spaced apart from said first side of said molded compartment; wherein said corresponding one of said auxiliary switches includes a first end, a second end disposed opposite and distal from the first end of said corresponding one of said auxiliary switches, a first side, and a second side disposed opposite and distal from the first side of said corresponding one of said auxiliary switches; wherein said first resilient tab is disposed on the first side of said molded compartment; wherein said retaining portion of said first resilient tab is a molded hook extending from at or about the first side of said molded compartment toward the second side of said molded compartment; wherein said second resilient tab extends from the first end of said molded compartment toward the second end of said molded compartment; and wherein, when said corresponding one of said auxiliary switches is disposed in said molded compartment, said molded hook of said first resilient tab overlays the second side of said corresponding one of said auxiliary switches, and said second resilient tab engages the first end of said corresponding one of said auxiliary switches and biases said corresponding one of said auxiliary switches toward the second end of said molded compartment.

6. The sub-assembly of claim 5 wherein said corresponding one of said auxiliary switches further includes a switch disposed on the first side of said corresponding one of said auxiliary switches, a lever extending from the first end of said corresponding one of said auxiliary switches and being coop-

19

erable with said switch, and a number of terminals disposed on the second end of said corresponding one of said auxiliary switches; wherein the first end of said molded compartment includes an opening; wherein the first side of said molded compartment comprises a molded recess; wherein the second end of said molded compartment includes an access hole; and wherein, when said corresponding one of said auxiliary switches is disposed in said molded compartment, said lever extends through said opening, said switch is received by said molded recess, and said number of terminals are accessible through said access hole.

7. A sub-assembly for an electrical switching apparatus including a housing having a mounting mechanism, and an actuating mechanism, said sub-assembly comprising:

a plurality of auxiliary switches;

an auxiliary switch tray comprising:

a module including a first side and a second side disposed opposite the first side;

a plurality of mounts disposed on the first side of said module, at least a plurality of said mounts receiving a corresponding one of said auxiliary switches;

a base disposed on the second side of said module and being removably coupled to said mounting mechanism, in order to install said auxiliary switches in a predetermined position with respect to said actuating mechanism of said electrical switching apparatus; and

wherein said mounting mechanism of said electrical switching apparatus is a first mounting rail and a second mounting rail; wherein said module further includes a first edge and a second edge disposed opposite and distal from the first edge of said module; wherein said base comprises a first lateral protrusion extending outwardly from the first edge of said module at or about the second side of said module, and a second lateral protrusion extending outwardly from the second edge of said module at or about the second side of said module; wherein said module is removably insertable into said electrical switching apparatus; and wherein, when said module is inserted into said electrical switching apparatus, said first lateral protrusion of said base of said module engages said first mounting rail and said second lateral protrusion of said base of said module engages said second mounting rail in order to align said module with respect to said electrical switching apparatus and to install said auxiliary switches in said predetermined position.

8. An electrical switching apparatus comprising:

a housing;

separable contacts enclosed by said housing;

an operating mechanism structured to open and close said separable contacts, said operating mechanism including an actuating mechanism;

a sub-assembly comprising:

a plurality of auxiliary switches being cooperable with said actuating mechanism;

an auxiliary switch tray comprising:

a module including a first side and a second side disposed opposite the first side;

a plurality of mounts disposed on the first side of said module, at least a plurality of said mounts receiving a corresponding one of said auxiliary switches;

a base disposed on the second side of said module, said base being removably coupled to said mounting mechanism, in order to install said auxiliary switches in a predetermined position with respect to said actuating mechanism of said electrical switching apparatus;

20

wherein each of said at least a plurality of said mounts is a molded compartment of said module; and wherein said molded compartment receives said corresponding one of said auxiliary switches and removably secures said corresponding one of said auxiliary switches to said module without a number of separate fasteners; and

wherein said molded compartment comprises a first resilient tab and a second resilient tab; wherein said first resilient tab includes a retaining portion; wherein said retaining portion of said first resilient tab is deflectable in order to receive said corresponding one of said auxiliary switches within said molded compartment; and wherein, when said corresponding one of said auxiliary switches is disposed within said molded compartment, said retaining portion retains said corresponding one of said auxiliary switches within said molded compartment, and said second resilient tab biases said corresponding one of said auxiliary switches into a desired orientation within said molded compartment.

9. The electrical switching apparatus of claim 8 wherein said molded compartment further comprises a first end, a second end disposed opposite and distal from the first end, a first side and a second side disposed opposite and spaced apart from said first side of said molded compartment; wherein said corresponding one of said auxiliary switches includes a first end, a second end disposed opposite and distal from the first end of said corresponding one of said auxiliary switches, a first side, and a second side disposed opposite and distal from the first side of said corresponding one of said auxiliary switches; wherein said first resilient tab is disposed on the first side of said molded compartment; wherein said retaining portion of said first resilient tab is a molded hook extending from at or about the first side of said molded compartment toward the second side of said molded compartment; wherein said second resilient tab extends from the first end of said molded compartment toward the second end of said molded compartment; and wherein, when said corresponding one of said auxiliary switches is disposed in said molded compartment, said molded hook of said first resilient tab overlays the second side of said corresponding one of said auxiliary switches, and said second resilient tab engages the first end of said corresponding one of said auxiliary switches and biases said corresponding one of said auxiliary switches toward the second end of said molded compartment.

10. The electrical switching apparatus of claim 9 wherein said corresponding one of said auxiliary switches further includes a switch disposed on the first side of said corresponding one of said auxiliary switches, a lever extending from the first end of said corresponding one of said auxiliary switches and being cooperable with said switch, and a number of terminals disposed on the second end of said corresponding one of said auxiliary switches; wherein the first end of said molded compartment includes an opening; wherein the first side of said molded compartment comprises a molded recess; wherein the second end of said molded compartment includes an access hole; and wherein, when said corresponding one of said auxiliary switches is disposed in said molded compartment, said lever extends through said opening, said switch is received by said molded recess, and said number of terminals are accessible through said access hole.

11. An electrical switching apparatus comprising:

a housing;

separable contacts enclosed by said housing;

an operating mechanism structured to open and close said separable contacts, said operating mechanism including an actuating mechanism;

21

a sub-assembly comprising:
 a plurality of auxiliary switches being cooperable with
 said actuating mechanism;
 an auxiliary switch tray comprising:
 a module including a first side and a second side
 disposed opposite the first side;
 a plurality of mounts disposed on the first side of said
 module, at least a plurality of said mounts receiving
 a corresponding one of said auxiliary switches;
 a base disposed on the second side of said module,
 said base being removably coupled to said mount-
 ing mechanism, in order to install said auxiliary
 switches in a predetermined position with respect
 to said actuating mechanism of said electrical
 switching apparatus; and
 wherein said mounting mechanism of said electrical
 switching apparatus is a first mounting rail and a second
 mounting rail; wherein said module further includes a
 first edge and a second edge disposed opposite and distal
 from the first edge of said module; wherein said base
 comprises a first lateral protrusion extending outwardly
 from the first edge of said module at or about the second
 side of said module, and a second lateral protrusion
 extending outwardly from the second edge of said mod-
 ule at or about the second side of said module; wherein
 said module is removably insertable into said electrical
 switching apparatus; and wherein, when said module is
 inserted into said electrical switching apparatus, said
 first lateral protrusion of said base of said module
 engages said first mounting rail and said second lateral
 protrusion of said base of said module engages said
 second mounting rail in order to align said module with
 respect to said electrical switching apparatus and to
 install said auxiliary switches in said predetermined
 position.

22

12. An electrical switching apparatus comprising:
 a housing;
 separable contacts enclosed by said housing;
 an operating mechanism structured to open and close said
 separable contacts, said operating mechanism including
 an actuating mechanism;
 a sub-assembly comprising:
 a plurality of auxiliary switches being cooperable with
 said actuating mechanism;
 an auxiliary switch tray comprising:
 a module including a first side and a second side
 disposed opposite the first side;
 a plurality of mounts disposed on the first side of said
 module, at least a plurality of said mounts receiving
 a corresponding one of said auxiliary switches;
 a base disposed on the second side of said module,
 said base being removably coupled to said mount-
 ing mechanism, in order to install said auxiliary
 switches in a predetermined position with respect
 to said actuating mechanism of said electrical
 switching apparatus; and
 wherein at least some of said auxiliary switches comprises
 a micro-switch including a switch, a lever cooperable
 with said switch, and a number of terminals; wherein at
 least some of said mounts of said module of said auxil-
 iary switch tray is a molded compartment; wherein said
 molded compartment includes a first end having an
 opening, a second end disposed opposite and distal from
 the first end of said molded compartment, and including
 an access hole, a first side comprising a molded recess,
 and a second side disposed opposite and distal from the
 first side; wherein said micro-switch is removably secur-
 able within said molded compartment; and wherein,
 when said micro-switch is disposed in said molded com-
 partment, said lever extends through said opening, said
 switch is received by said molded recess, and said num-
 ber of terminals are accessible through said access hole.

* * * * *