



US007855988B2

(12) **United States Patent**
Pan

(10) **Patent No.:** **US 7,855,988 B2**
(45) **Date of Patent:** **Dec. 21, 2010**

(54) **SYSTEM, METHOD, AND DEVICE FOR ROUTING CALLS USING A DISTRIBUTED MOBILE ARCHITECTURE**

2006/0258358 A1 11/2006 Kallio
2007/0147598 A1 6/2007 Somes et al.
2007/0230352 A1 10/2007 Kokku et al.

(75) Inventor: **Shaowei Pan**, Kildeer, IL (US)

(73) Assignee: **Lemko Corporation**, Schaumburg, IL (US)

(*) Notice: Subject to any disclaimer, the term of this patent is extended or adjusted under 35 U.S.C. 154(b) by 249 days.

(21) Appl. No.: **12/172,639**

(22) Filed: **Jul. 14, 2008**

(65) **Prior Publication Data**

US 2010/0008369 A1 Jan. 14, 2010

(51) **Int. Cl.**
H04W 4/00 (2009.01)

(52) **U.S. Cl.** **370/328; 370/401; 370/352**

(58) **Field of Classification Search** None
See application file for complete search history.

(56) **References Cited**

U.S. PATENT DOCUMENTS

7,054,322 B2 *	5/2006	D'Annunzio et al.	370/401
2002/0009060 A1 *	1/2002	Gross	370/321
2003/0048766 A1 *	3/2003	D'Annunzio et al.	370/338
2005/0091392 A1	4/2005	Gesswein et al.	
2006/0098661 A1	5/2006	Pan	
2006/0114934 A1 *	6/2006	Shin et al.	370/466

OTHER PUBLICATIONS

International Search Report and Written Opinion in corresponding PCT Application No. PCT/US2009/045973 from the International Searching Authority (KR) mailed Jan. 18, 2010, 14 pages.

* cited by examiner

Primary Examiner—Bob A Phunkulh

(74) *Attorney, Agent, or Firm*—Toler Law Group, IP

(57) **ABSTRACT**

Methods and devices for routing communications between distributed mobile architecture (DMA) servers using DMA gateways are disclosed. Communications information is received at a first DMA gateway for a communications network accessible by a second DMA gateway. The communications information indicates one or more devices that are accessible by one of a DMA server and a legacy communications network. The first DMA gateway and the second DMA gateway participate in a DMA gateway communications network. The communications information is stored in a home DMA register of the first DMA gateway. A communication is received at the first DMA gateway for a target device indicated by the communications information to be served by the second DMA gateway. The communication is routed from the first DMA gateway to the target device by relaying the communication from the first DMA gateway to the second DMA gateway via the DMA gateway communications network.

45 Claims, 15 Drawing Sheets

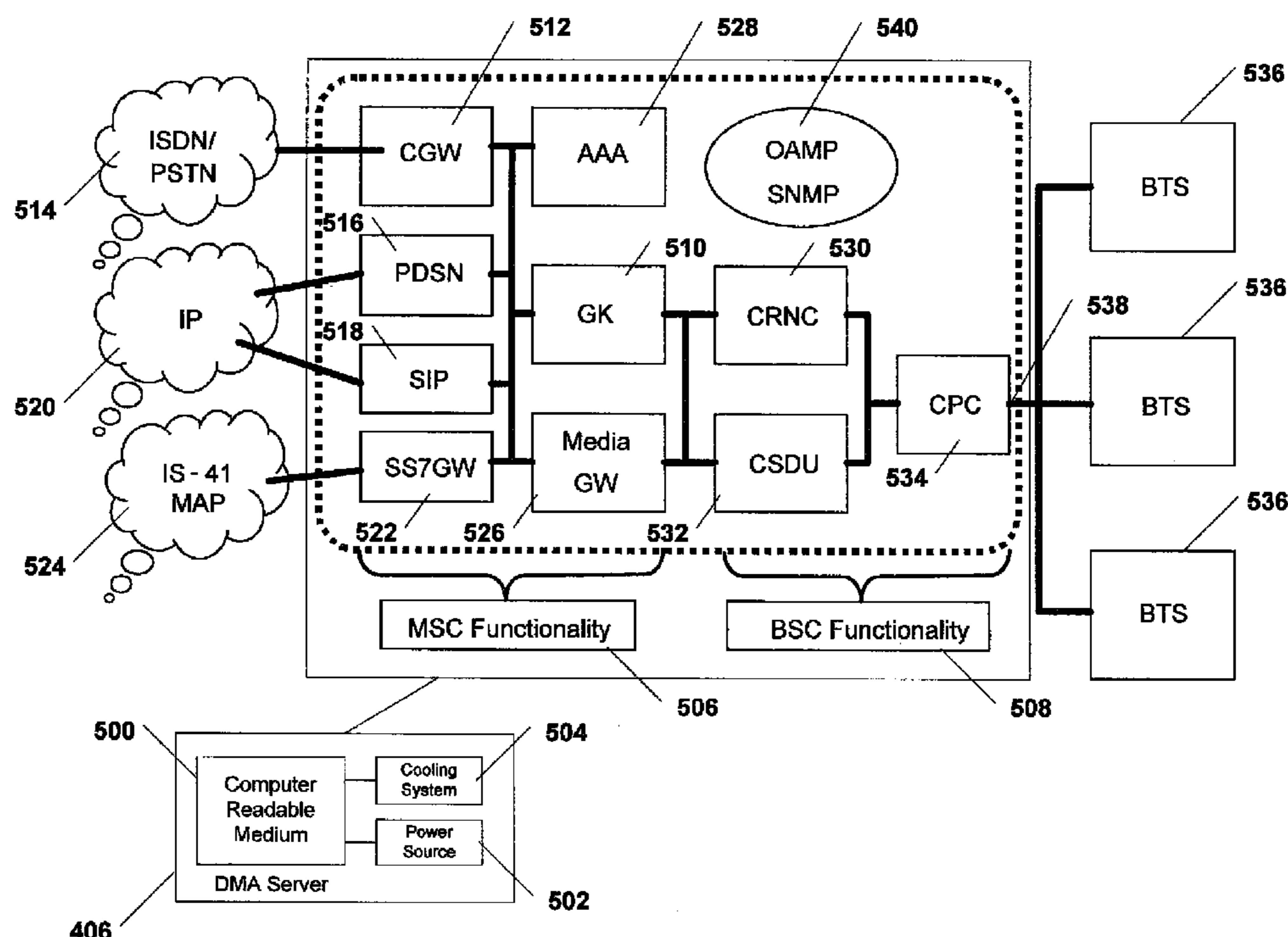

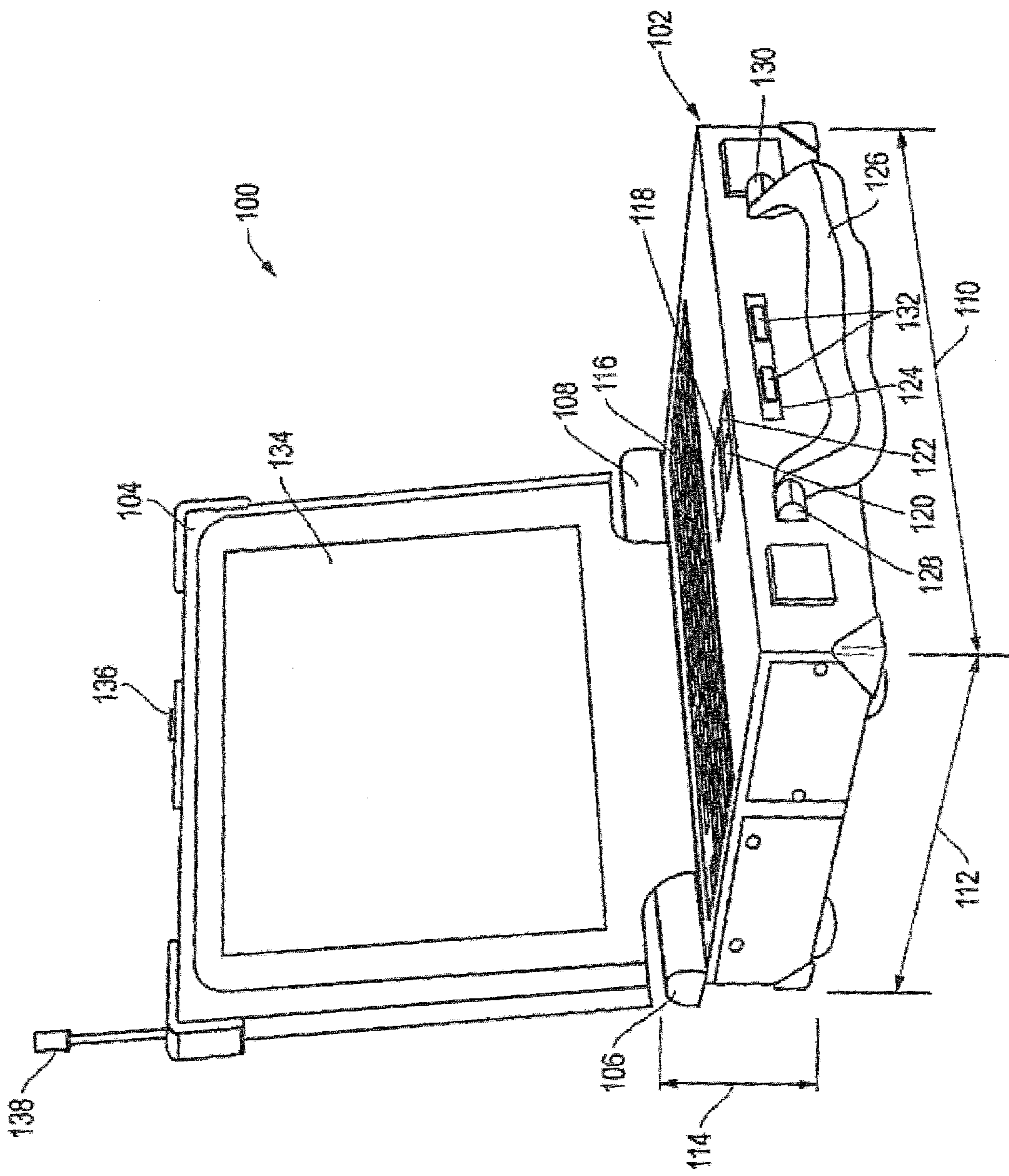

FIG. 1

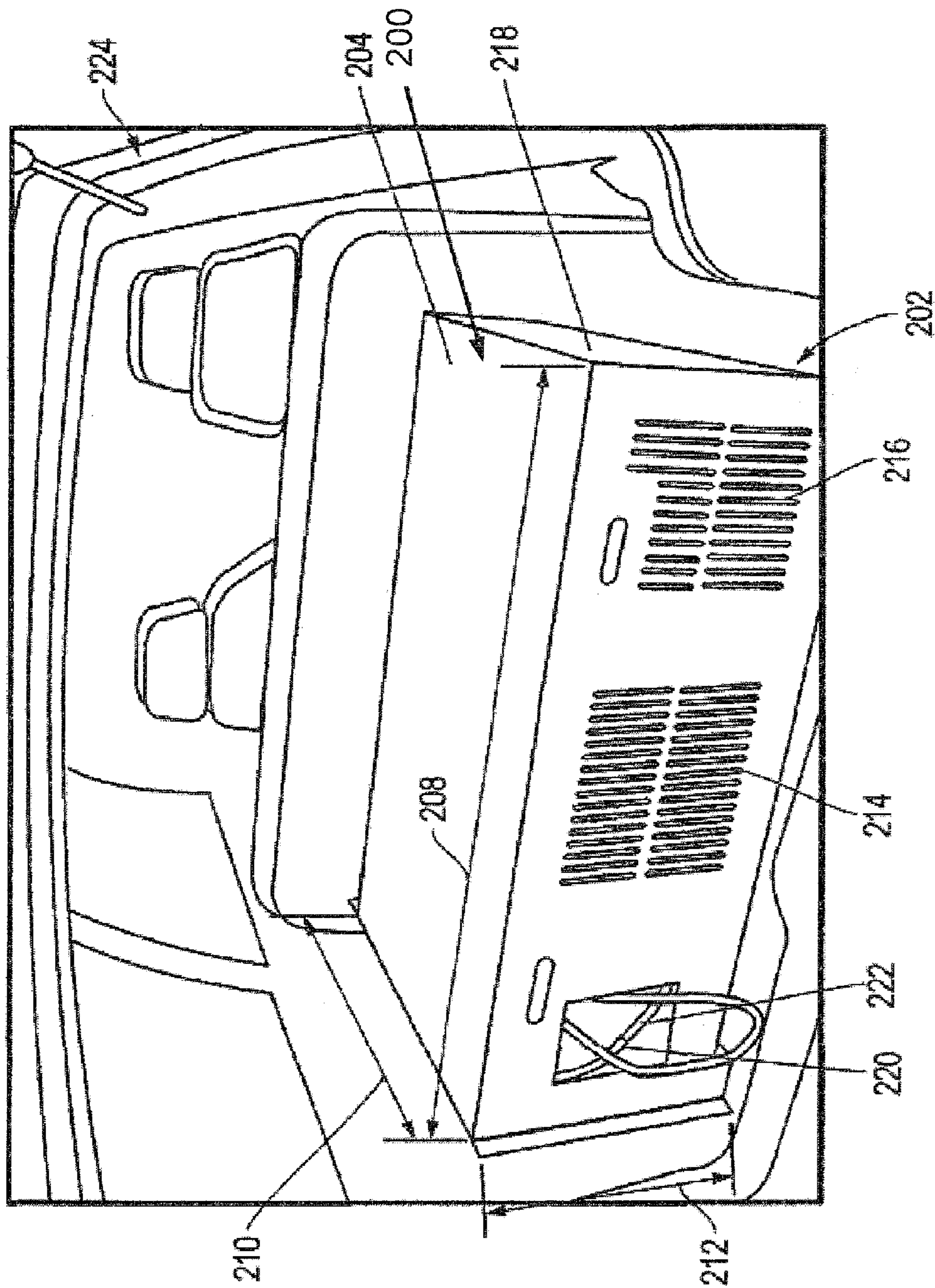

FIG. 2

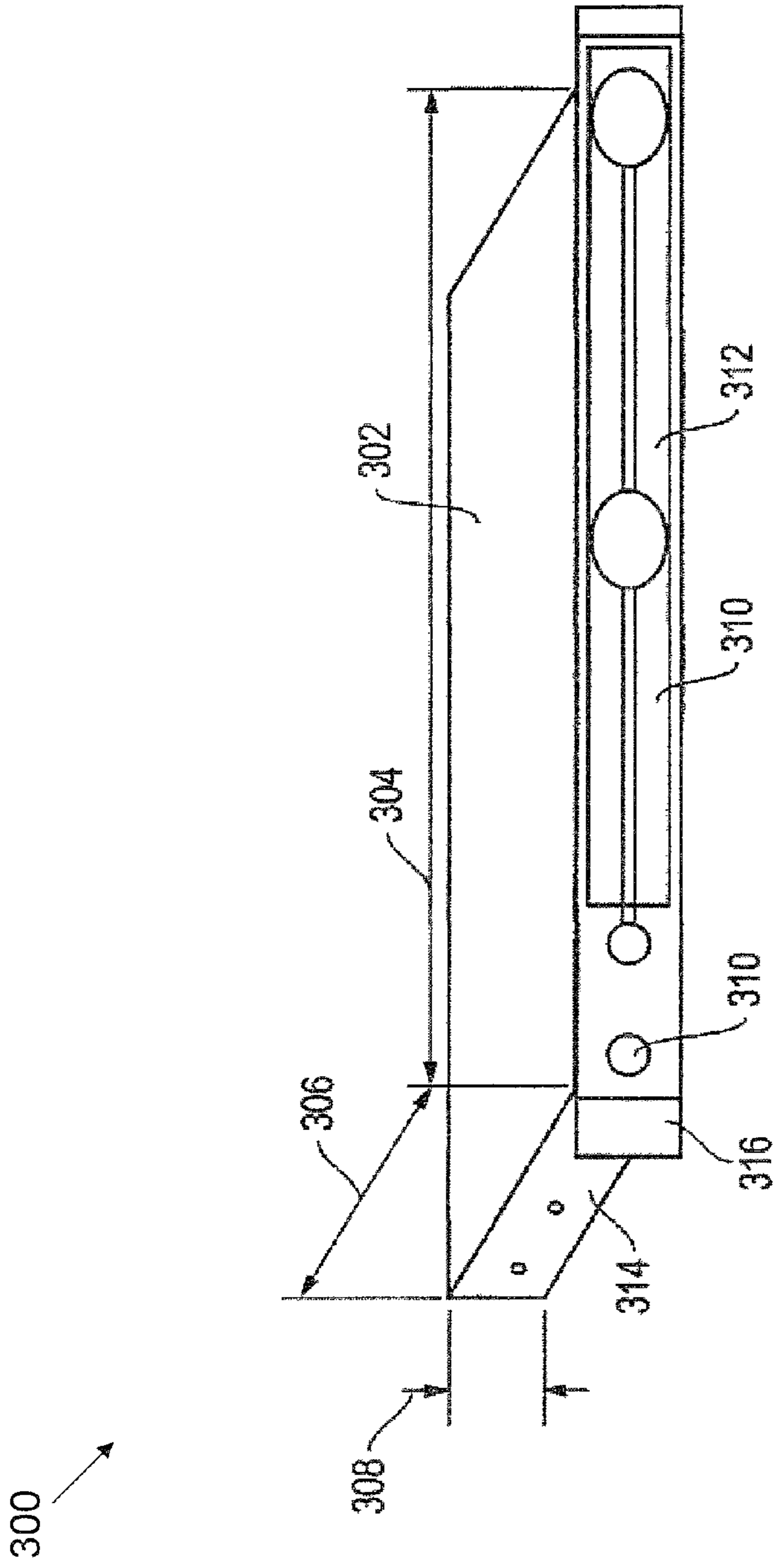

FIG. 3

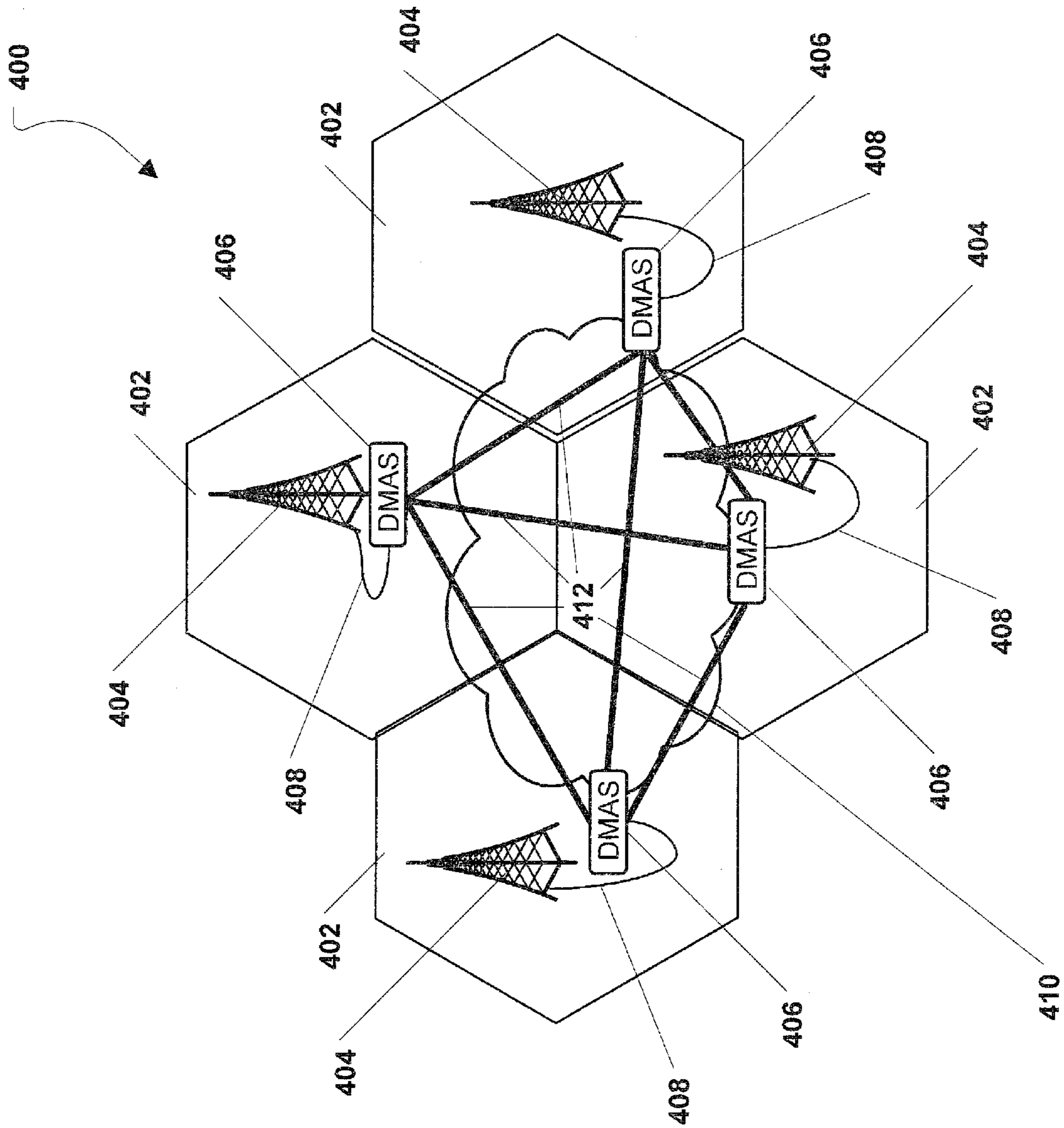

FIG. 4

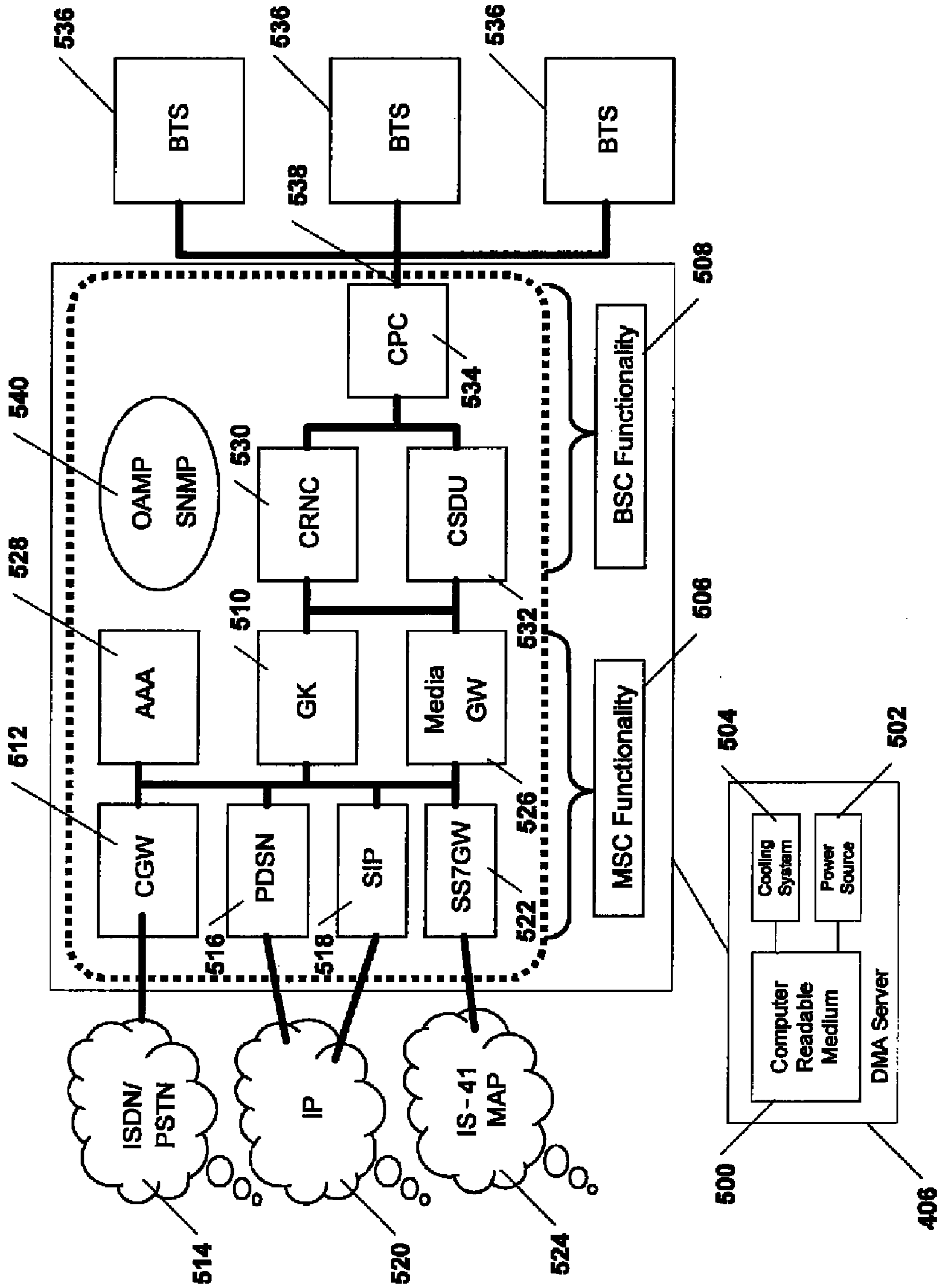

FIG. 5

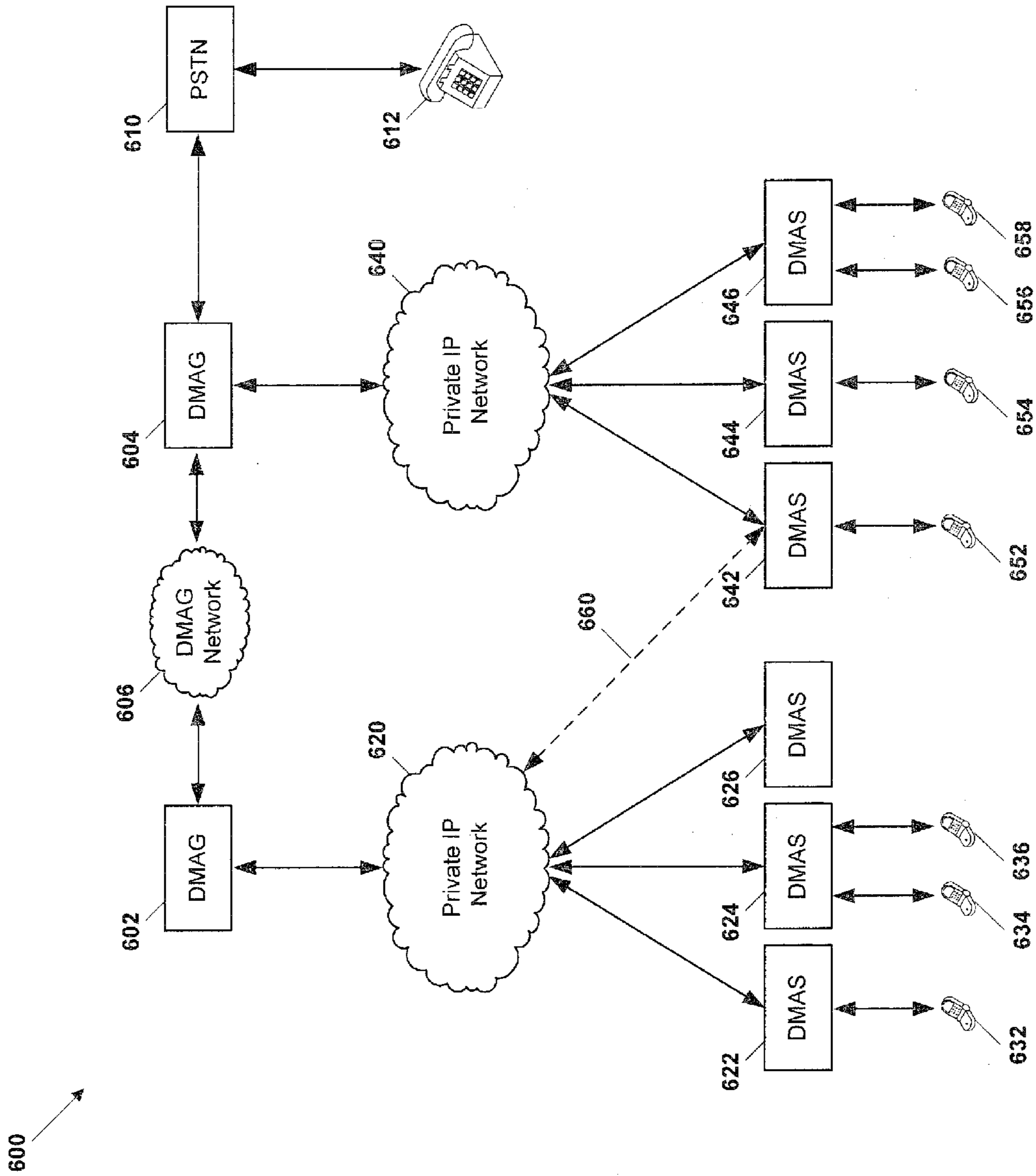

FIG. 6

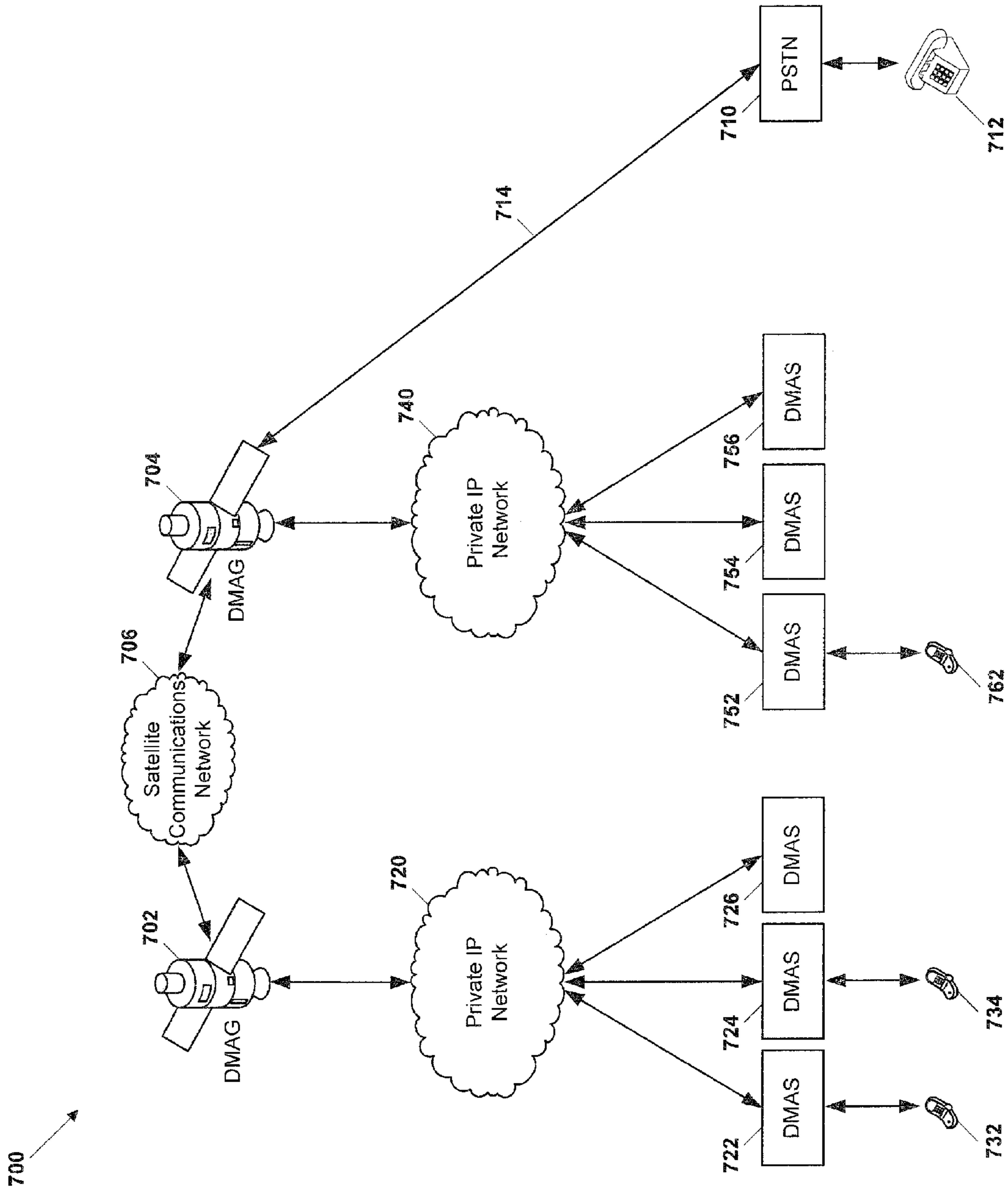

FIG. 7

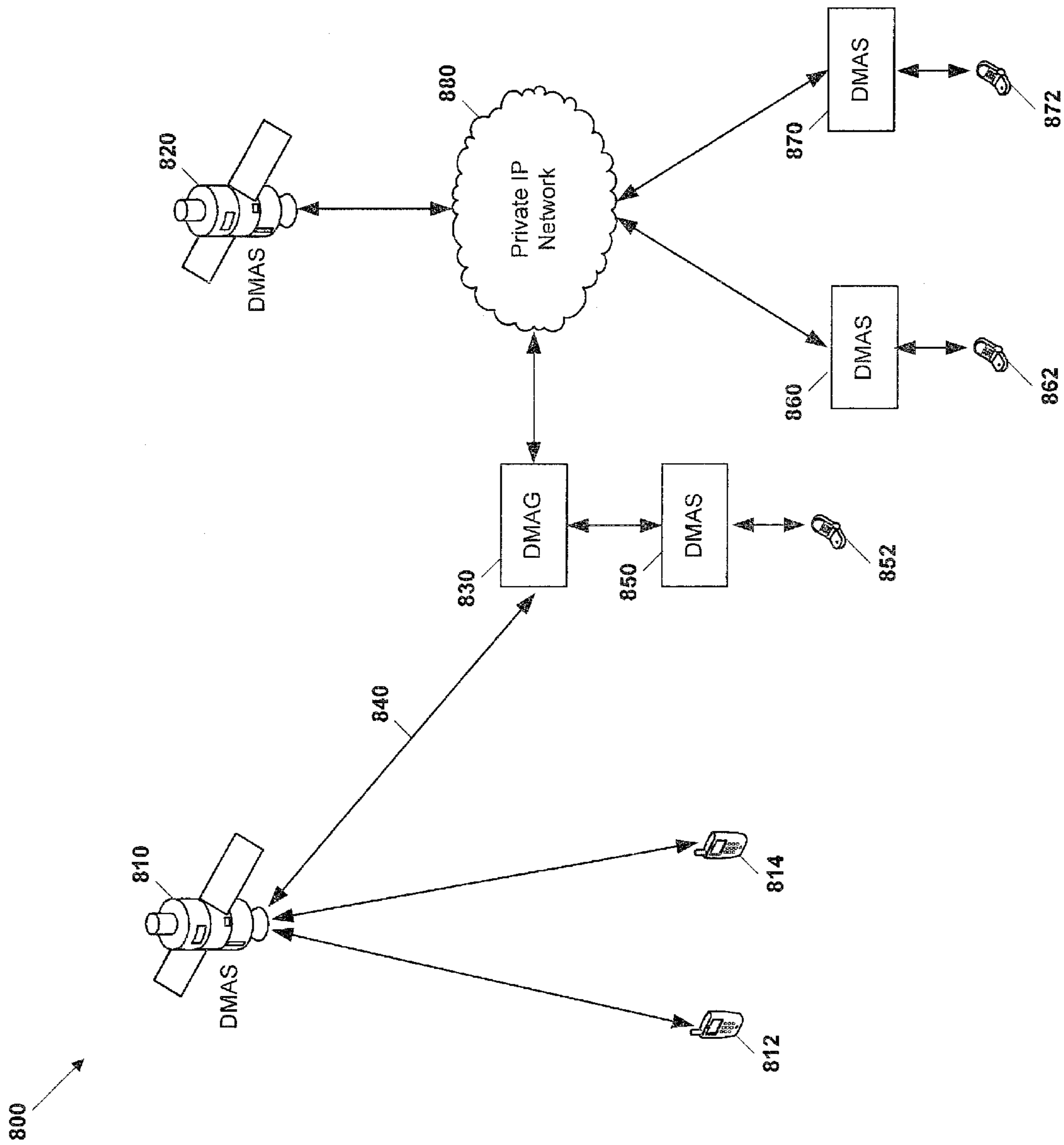

FIG. 8

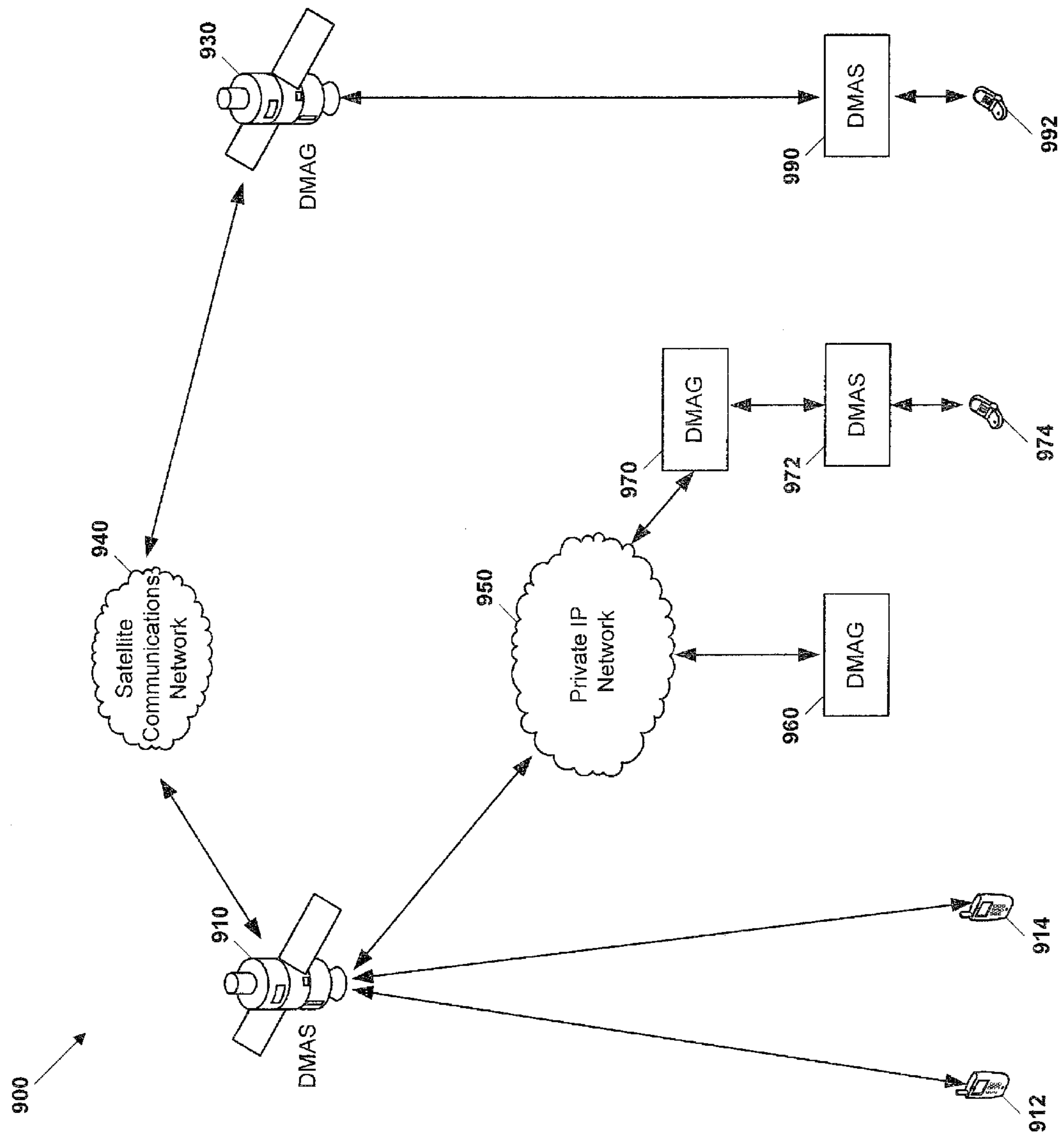

FIG. 9

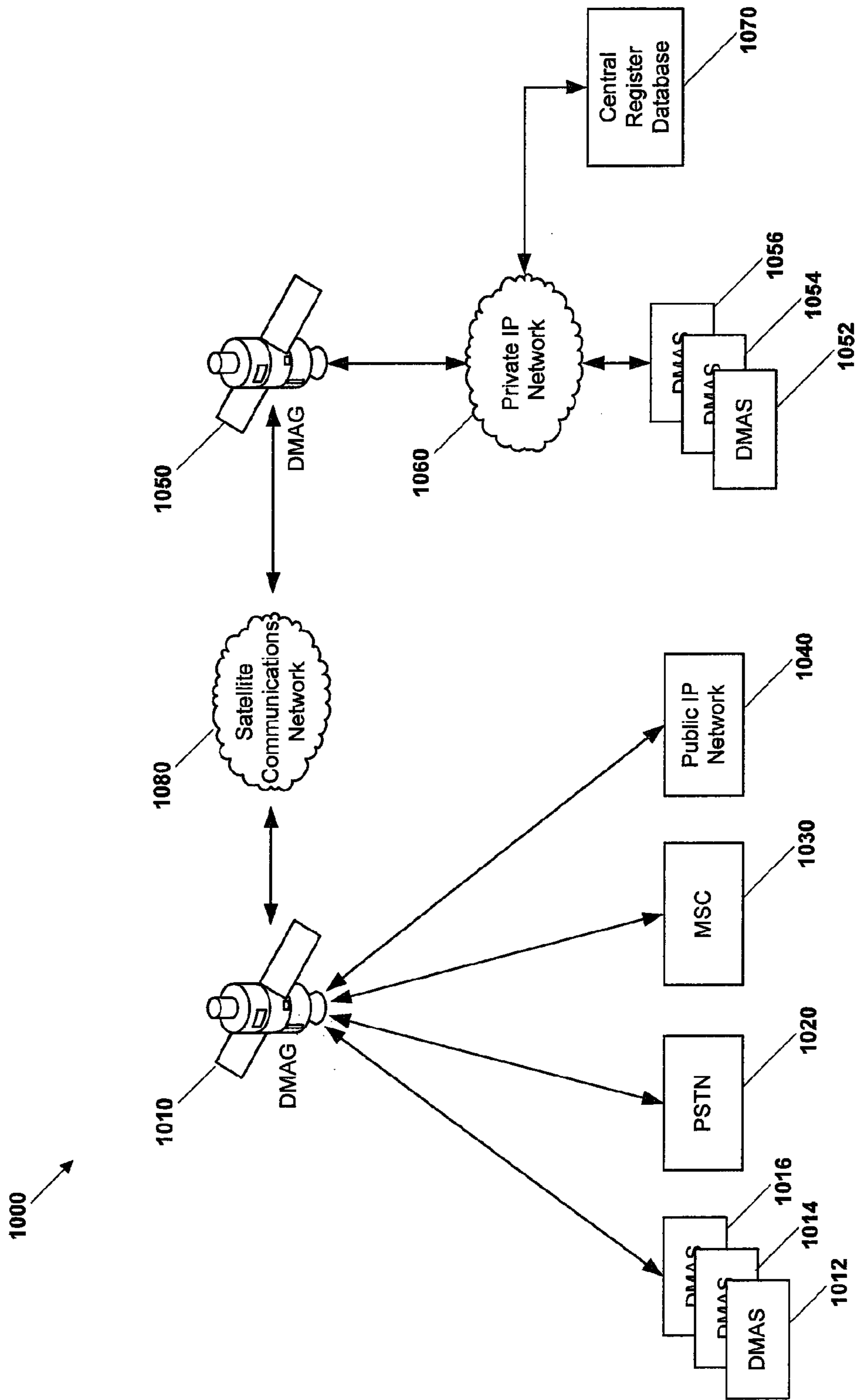

FIG. 10

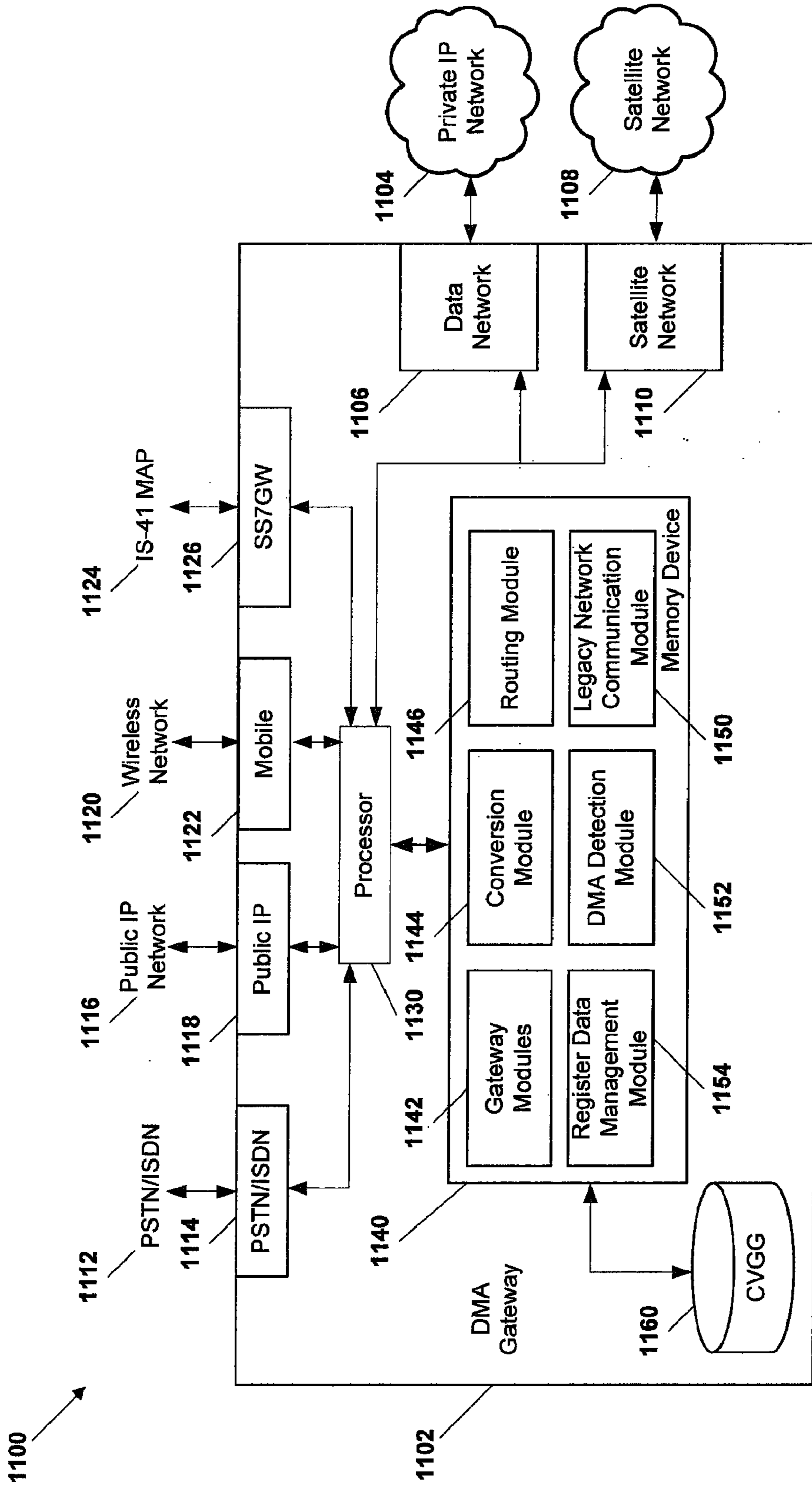

FIG. 11

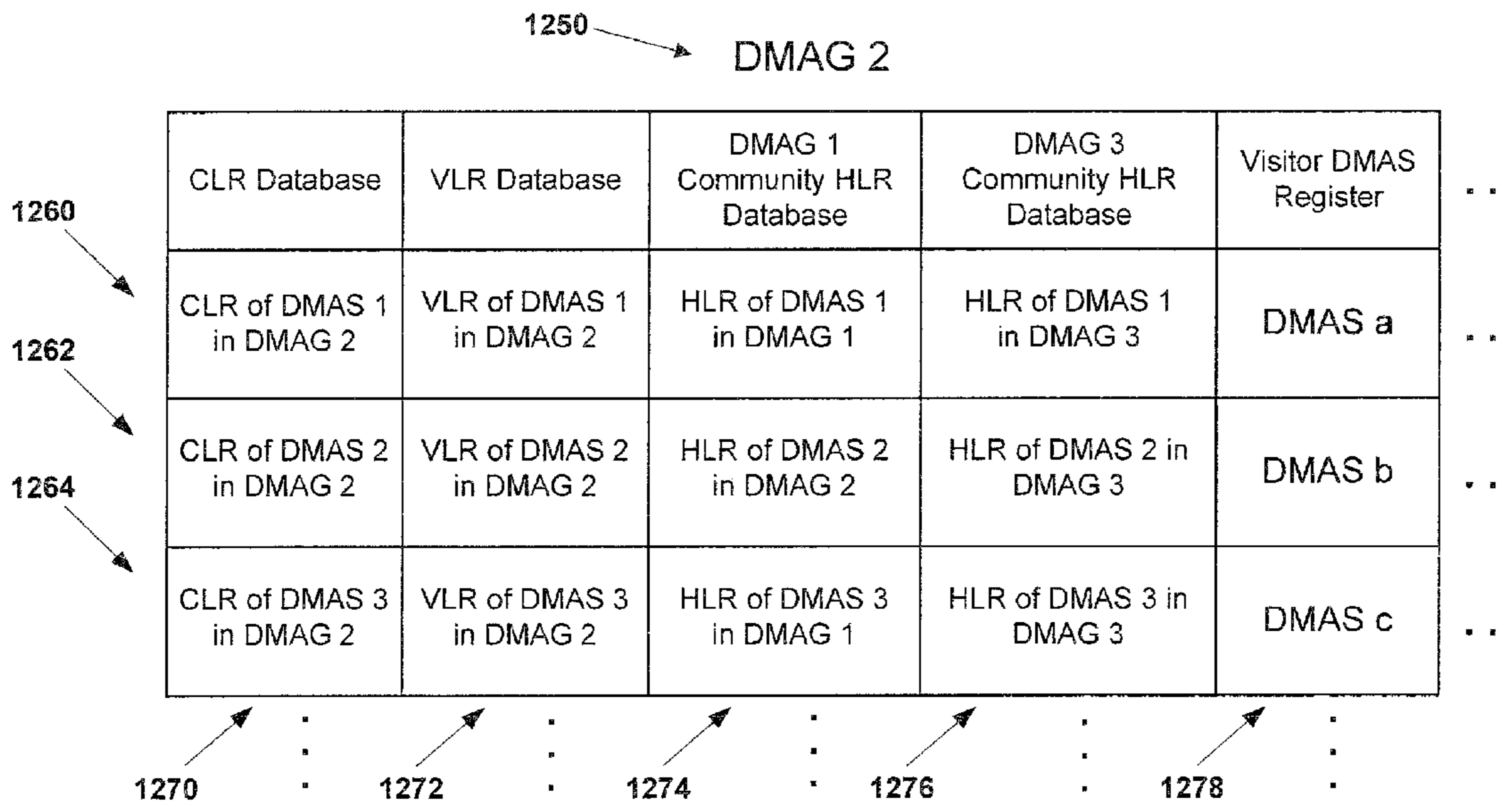
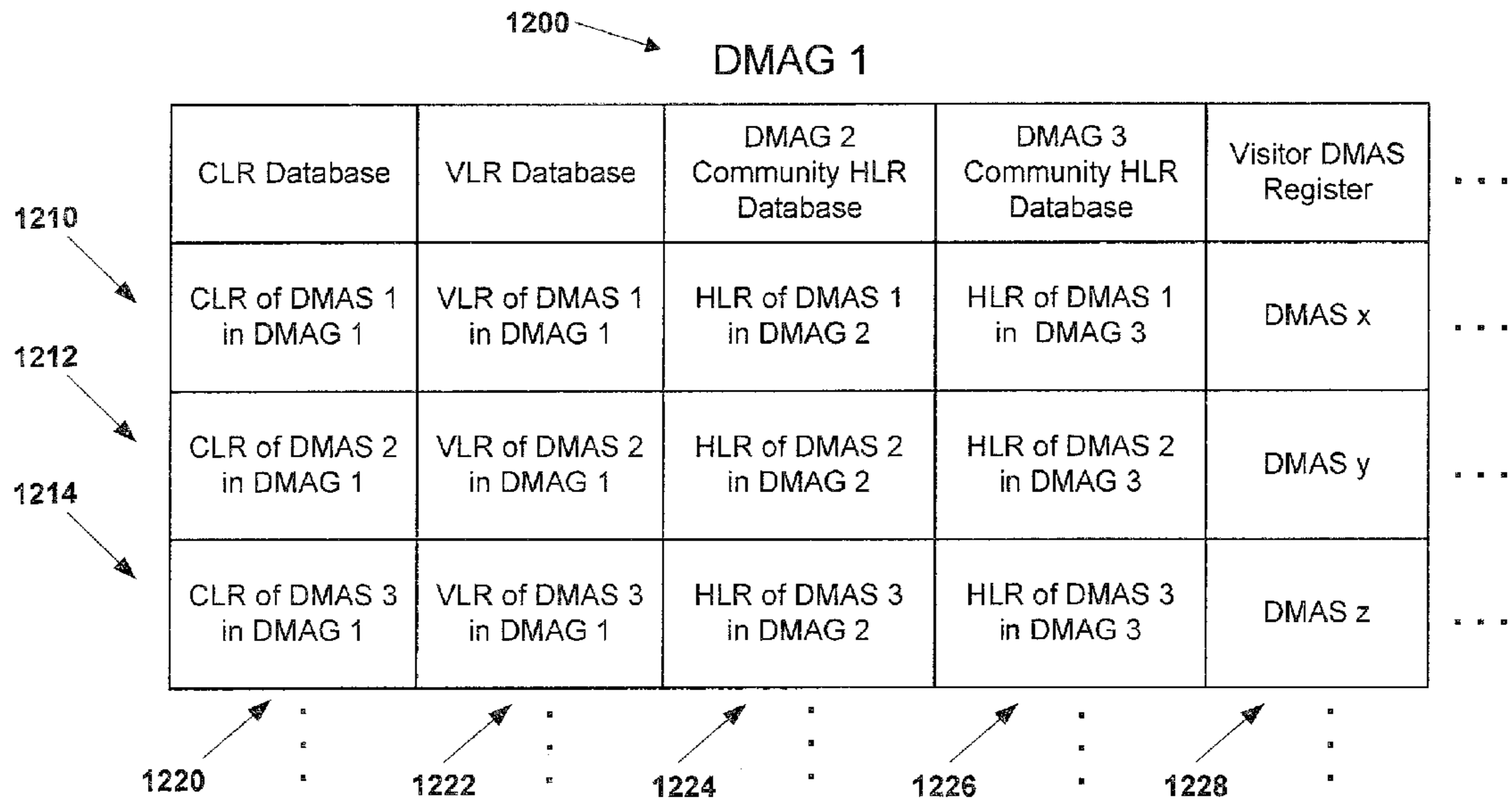

FIG. 12

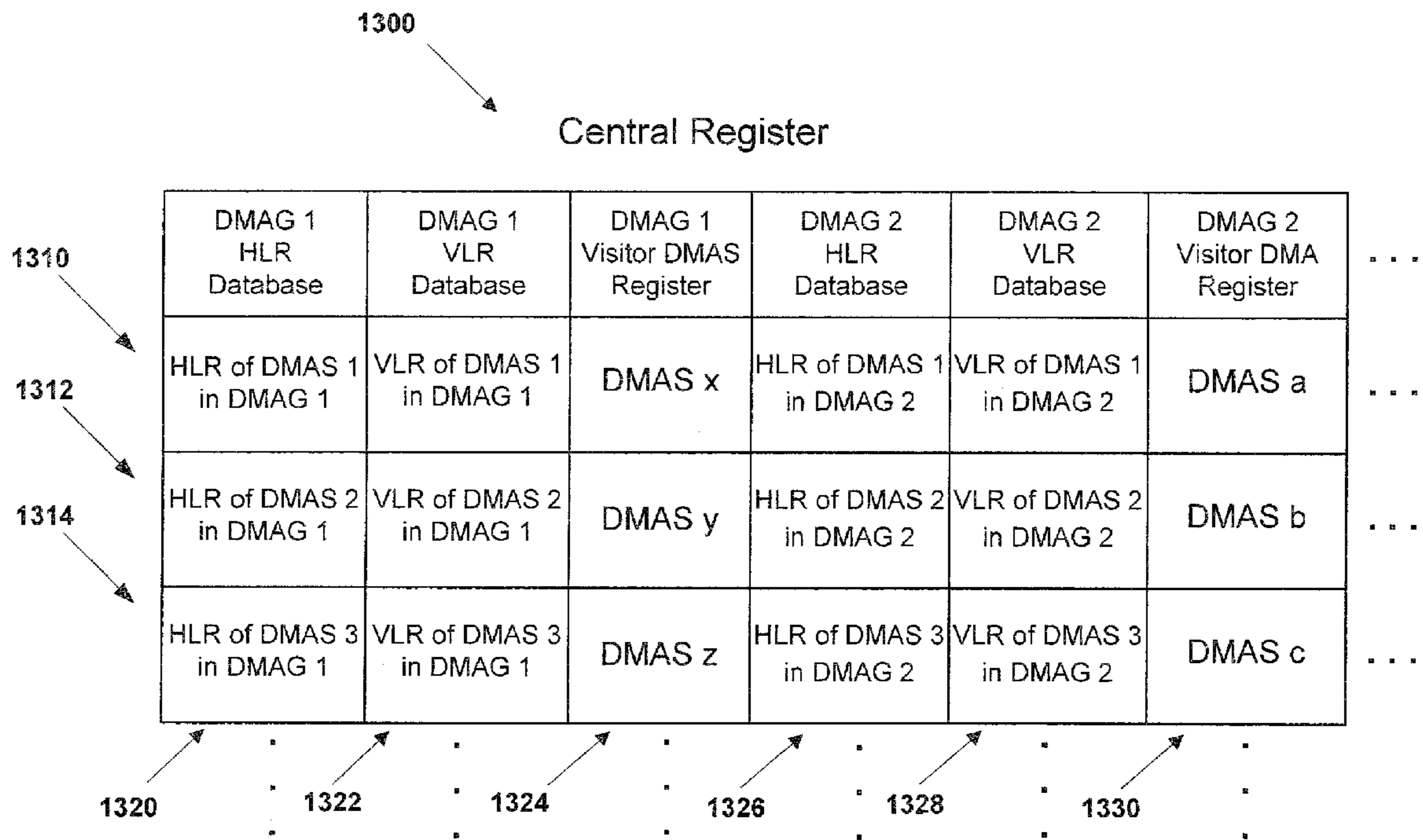

FIG. 13

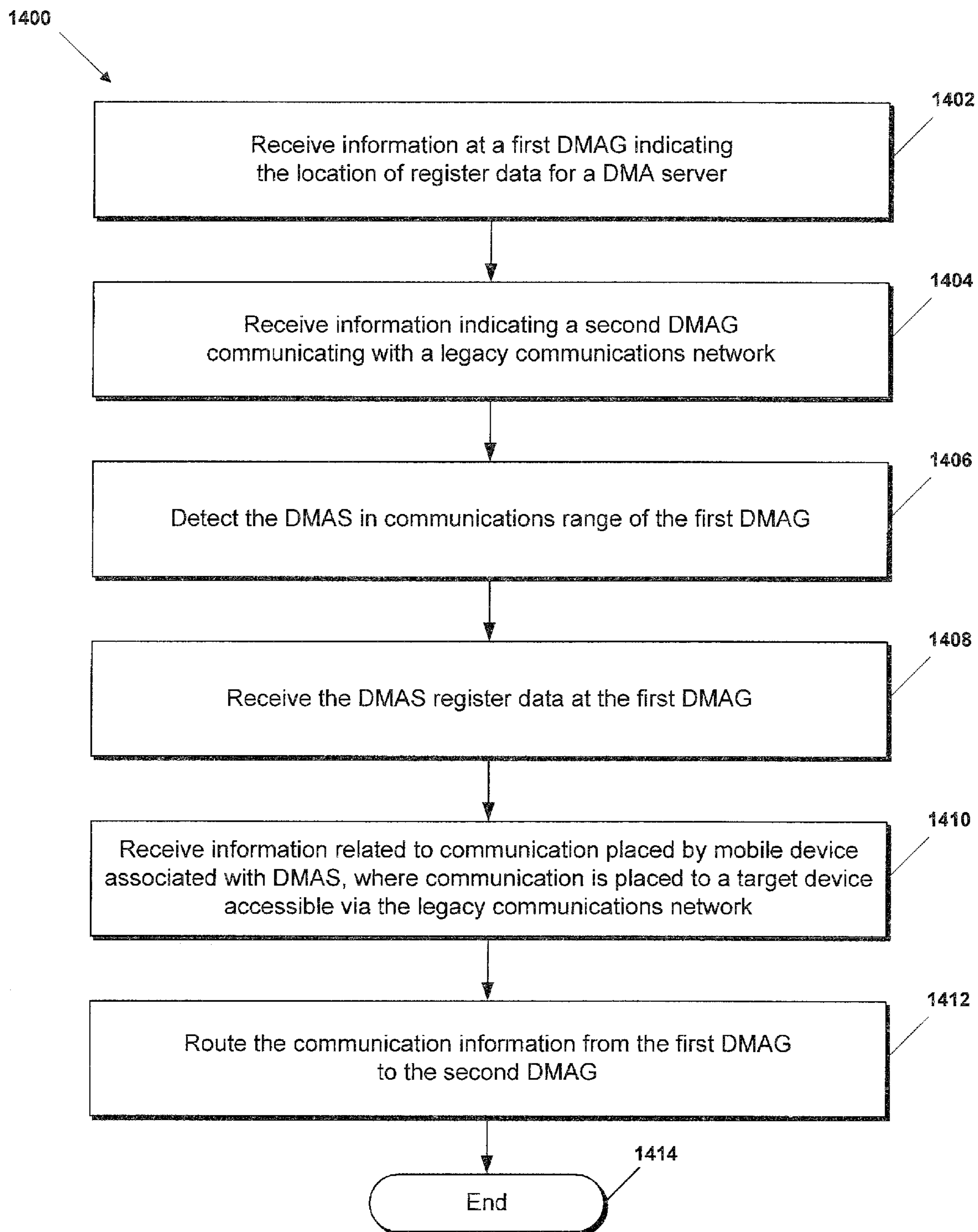

FIG. 14

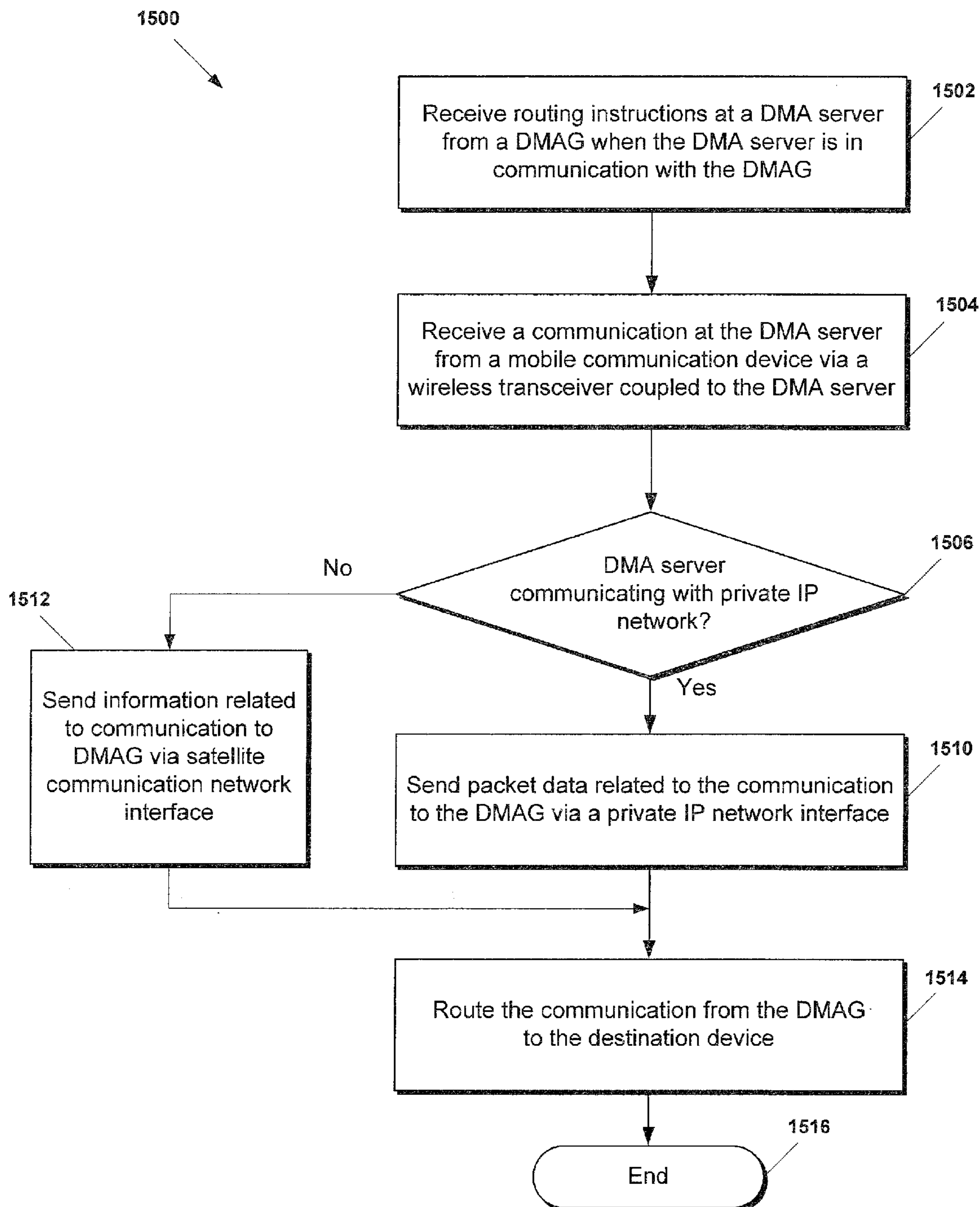

FIG. 15

1

**SYSTEM, METHOD, AND DEVICE FOR
ROUTING CALLS USING A DISTRIBUTED
MOBILE ARCHITECTURE**

FIELD OF THE DISCLOSURE

The present disclosure relates generally to distributed mobile communications systems.

BACKGROUND

Access to basic telephony service is particularly important for rural and isolated communities. Telephony access allows small-scale enterprises, cooperatives, and farmers to obtain accurate information on fair prices for their products and to access regional and national markets. Access also reduces the cost of transportation and supports the local tourist industry. By bringing markets to people via telecommunications, rather than forcing people to leave in search of markets, urban migration is reduced and greater income and employment potential are generated in rural areas.

Unfortunately, the last decade of the telecommunications boom has not alleviated the disparities between urban and rural communities. The average imbalance, in terms of telephone penetration, in Asia, for example, is over ten to one and is often as high as twenty to one. This means that a country whose urban markets have a penetration of four (4) telephone lines per one-hundred (100) inhabitants, e.g., India and Pakistan, has a rural penetration of less than 0.2 per one-hundred (100). The situation is more acute in most African countries and in some parts of Latin America. By comparison, the disparity in average income level between urban and rural residents in the developing world is usually less than 4 to 1.

Current telephone systems are expensive to deploy. For example, a typical cellular system that includes a mobile switching center (MSC), a base station controller (BSC), and a home location register/visitor location register (HLR/VLR) can cost over \$2.0 million. Moreover, such a system may require a minimum of ten thousand users in order to be economically viable. In many rural areas, the population is not large enough to support the installation of such a system. Further, in many cases, the conditions in which the equipment (e.g., the MSC, BSC, and HLR/VLR) are to be operated are extremely harsh and environmentally prohibitive. An alternative to such a cellular system can include a wired system, but the costs associated with deploying and maintaining land lines are too high for certain rural areas.

In deploying telephone systems in such situations, a further concern is how to expand an existing telephone system or implement a new phone system capable of operating with existing telephone systems. For example, it may be desirable to allow communications with users serviced by existing public switched telephone network (PSTN) services, Voice over Internet Protocol (VoIP) systems, wireless communications systems, and other systems. Providing compatibility between these systems presents a challenge in itself. Moreover, because some of these systems may be deployed in rural or other remote areas, providing a medium through which newly deployed systems can communicate with one another presents a concern.

Accordingly, there exists a need for an improved communications system that is relatively inexpensive to deploy and

2

relatively inexpensive to operate, as well as able to integrate different communications systems.

BRIEF DESCRIPTION OF THE DRAWINGS

5

The present invention is pointed out with particularity in the appended claims. However, other features are described in the following detailed description in conjunction with the accompanying drawings in which:

10 FIG. 1 is a view of a particular illustrative embodiment of a distributed mobile architecture (DMA) server having a first illustrative form factor;

15 FIG. 2 is a view of another particular illustrative embodiment of an alternative embodiment of a DMA server having a second illustrative form factor;

FIG. 3 is a diagram of another particular illustrative embodiment of an alternative embodiment of a DMA server having a third illustrative form factor;

20 FIG. 4 is a diagram of a particular illustrative embodiment of a distributed and associative communications system;

FIG. 5 is a block diagram of a particular illustrative embodiment of a DMA server;

25 FIG. 6 is a diagram of a particular illustrative embodiment of a network incorporating a plurality of DMA gateways linking a plurality of DMA servers and a legacy network;

FIG. 7 is a diagram of a particular illustrative embodiment of a network incorporating a plurality of satellite-based DMA gateways linking a plurality of DMA servers and a legacy network;

30 FIG. 8 is a diagram of a particular illustrative embodiment of a network incorporating a DMA gateway linking a plurality of satellite-based DMA servers and ground-based DMA servers;

35 FIG. 9 is a diagram of a particular illustrative embodiment of a network incorporating a plurality of satellite-based and ground-based DMA gateways linking a plurality of satellite-based and ground-based DMA servers;

40 FIG. 10 is a diagram of a particular illustrative embodiment of a network incorporating a plurality of DMA gateways and a plurality of legacy networks utilizing a central register database for communications devices accessible within the network;

FIG. 11 is a block diagram of a particular illustrative embodiment of a DMA gateway;

45 FIG. 12 is a diagram of a particular illustrative embodiment of an exemplary data structure used by a DMA gateway for maintaining information about communications devices accessible through other gateways;

50 FIG. 13 is a diagram of a particular illustrative embodiment of an exemplary structure maintained in a central database accessible by DMA gateways to maintain information about communications devices accessible throughout a network;

55 FIG. 14 is a flow chart to illustrate a particular illustrative embodiment of the use of information about accessible networks and devices for routing communications between DMA gateways; and

60 FIG. 15 is a flow chart to illustrate a particular illustrative embodiment of a selective routing of a communication by a DMA gateway via a private Internet Protocol network or a gateway network.

DETAILED DESCRIPTION OF THE DRAWINGS

65 Methods and devices for routing communications between distributed mobile architecture (DMA) servers using DMA gateways are disclosed. Communications information is received at a first DMA gateway for a communications net-

work accessible by a second DMA gateway. The communications information indicates one or more devices that are accessible by one of a DMA server and a legacy communications network. The first DMA gateway and the second DMA gateway participate in a DMA gateway communications network. The communications information is stored in a home DMA register of the first DMA gateway. A communication is received at the first DMA gateway for a target device indicated by the communications information to be served by the second DMA gateway. The communication is routed from the first DMA gateway to the target device by relaying the communication from the first DMA gateway to the second DMA gateway via the DMA gateway communications network.

In a particular embodiment, a first distributed mobile architecture (DMA) gateway includes a number of interfaces. A first interface is adapted to communicate with a legacy communications network. A second interface is adapted to communicate with a private Internet Protocol (IP) network. A third interface is adapted to communicate with a DMA gateway communications network. The gateway also includes a server having logic adapted to receive legacy network information from a second DMA gateway, the legacy network information indicating that the legacy communications network is in a communications range of the second DMA gateway. The DMA gateway forwards information associated with a communication received from a DMA server via the second interface to the second DMA gateway via the third interface. The call is placed to a destination device accessible via the legacy communications network.

In another particular embodiment, first routing instructions at a first distributed mobile architecture (DMA) server from a first DMA gateway when the first DMA server is in a first service area of the first DMA gateway. The first DMA gateway comprises a first orbiting satellite. A first call received at the first DMA server from a first mobile communications device via a wireless transceiver integrated with the first DMA server is sent to the first DMA gateway via a private Internet Protocol (IP) network according to the first routing instructions. The first call is placed to a destination device accessible via a legacy communications network, the legacy communications network accessible via the first DMA gateway.

In another embodiment, a distributed mobile architecture (DMA) server is coupled to a wireless transceiver. The DMA server includes a first interface adapted to communicate with a private Internet Protocol (IP) network and a second interface adapted to communicate with a satellite communications network. The DMA server includes a server having logic adapted to receive a call from a mobile communications device via the wireless transceiver and send call information related to the call to a DMA gateway. The DMA gateway comprises an orbiting satellite. The call is placed to a destination device accessible via a legacy communications network, the legacy communications network accessible via the DMA gateway.

In yet another embodiment, an orbiting satellite includes a first interface adapted to communicate with a legacy communications network and a second interface adapted to communicate with a private Internet Protocol (IP) network. The satellite also includes a server having logic adapted to receive a call via the first interface. The call is placed to a first mobile communications device accessible to a first distributed mobile architecture (DMA) server. The call is then routed to the first DMA server via the second interface, wherein the first DMA server includes a wireless transceiver to communicate with the first mobile communications device.

According to the present disclosure, one or more of the communications devices between which a communication, such as a voice communication and/or a data communication, participates in a communications network via a DMA server. A DMA server enables the deployment or expansion of a communications network to, for example, rural areas where remoteness of the area to be served or a relatively small customer base to be served make the installation of a conventional telephone system impractical or otherwise undesirable. As further described below according to embodiments of this disclosure, while one or more DMA servers may communicate with one another over a private IP network, when a private IP network is not available, the DMA servers may communicate through a plurality of DMA gateways that communicate with one another through a gateway communications network. For example, the DMA gateways may be implemented as orbiting satellites that participate in a gateway communications network that includes a satellite communications network.

In introducing the operation of DMA gateways, exemplary embodiments of DMA servers and their operation are described below.

Referring to FIG. 1, a DMA server is shown and is generally designated **100**. As illustrated in FIG. 1, the DMA server **100** includes a base **102** and a lid **104**. As shown, the lid **104** is attached to the base by a first lid hinge **106** and a second lid hinge **108**. In a particular embodiment, the lid **104** can be rotated about the first lid hinge **106** and the second lid hinge **108** between an open position, shown in FIG. 1, and a closed position (not shown) in which the lid **104** overlays the base **102** and the DMA server **100** is essentially shaped like a box or a briefcase.

As indicated in FIG. 1, the base **102** has a length **110**, a width **112** and a height **114**. FIG. 1 shows that the DMA server **100** includes a keyboard input device **116** that is incorporated in an upper surface of the base **102**. Further, the DMA server **100** includes a mouse input device **118** that is also incorporated into the upper surface of the base **102**. In a particular embodiment, the mouse input device **118** is a touch mouse input device **118**. Additionally, the DMA server **100** includes a left side button **120** and a right side button **122**. In a particular embodiment, the left side button **120** can be used to perform left-click functionality associated with the mouse input device **118**. Moreover, the right side button **122** can be used to perform right-click functionality associated with the mouse input device **118**.

FIG. 1 further indicates that the base **102** of the DMA server **100** is formed with a vent **124** to permit air exchange with the interior of the base **102** of the DMA server **100** and to facilitate cooling of the electronic components of the DMA server **100** housed within the base **102**. Moreover, the base **102** of the DMA server **100** includes a handle **126** that is attached to the base **102** via a first handle hinge **128** and a second handle hinge **130**. The base **102** also includes a pair of latch engagement notches **132**.

As shown in FIG. 1, the lid **104** includes a flat panel display **134** incorporated therein. When the lid **104** is closed, the display **134** is adjacent to the keyboard **116**. Moreover, when the lid **104** is closed, the lid **104** and the base **102** cooperate to protect the display **134**, the keyboard **116**, the mouse **118**, and the buttons **120**, **122**. FIG. 1 also depicts a latch **136** that is incorporated into the lid **104**. When the lid **104** is closed, the latch **136** can engage the latch engagement notches **132** in order to lock the lid in the closed position. As depicted in FIG. 1, an antenna **138** is incorporated into the lid **104**. The antenna **138** can be extended during operation and retracted when the DMA server **100** is not operating.

5

In a particular embodiment, the length **110** of the base **102** is 31.0 centimeters. Further, in a particular embodiment, the width **112** of the base **102** is 25.5 centimeters. Additionally, in a particular embodiment, the height **114** of the base **102** with the lid **104** in the closed position is 7.0 centimeters. Accordingly, the DMA server **100** has a total volume of 5,533.5 centimeters cubed and a footprint area of 790.5 centimeters squared. Further, in a particular embodiment, the DMA server **100** weighs approximately 5.8 kilograms (kg). As such, in a particular embodiment, the DMA server **100** has a total volume that is less than 6,000 centimeters cubed, a footprint area that is less than 800 centimeters squared, and a weight that is less than 6.0 kilograms.

In a particular embodiment, the DMA server **100** is relatively rugged. Particularly, the DMA server **100** is operable in a temperature range from negative twenty degrees Celsius to positive fifty-five degrees Celsius (-20°C . to 55°C .). Also, the DMA server **100** is substantially shock resistant and can withstand a one meter drop. Further, the DMA server **100** is substantially weather resistant, substantially dust resistant, and substantially sand resistant. The DMA server **100** is portable and it can be mounted in a vehicle or carried like a brief case. Further, multiple DMA servers **100** can be deployed as described herein.

FIG. 2 depicts an alternative embodiment of a distributed mobile architecture (DMA) server that is generally designated **200**. As shown in FIG. 2, the DMA server **200** includes a base **202** and a lid **204** that is coupled to the base **202** via a plurality of fasteners (not shown). Additionally, the DMA server **200** has a length **208**, a width **210**, and a height **212**. Further, the base **202** of the DMA server **200** includes a first vent **214**, a second vent **216**, and a third vent **218**. In a particular embodiment, the vents **214**, **216**, **218** permit air exchange with the interior of the base **202** of the DMA server **200** and facilitate cooling of the electronic components of the DMA server **200** housed within the base **202**. As shown in FIG. 2, the DMA server **200** includes an access window **220**. One or more interfaces **222**, e.g., wires can be accessed via the access window **220** and coupled to a base transceiver station (BTS) during deployment of the DMA server **200**. As shown in FIG. 2, the DMA server **200** can be mounted within a vehicle **224**. Further, multiple DMA servers **200** can be deployed as described herein.

In a particular embodiment, the length **208** of the base **202** is 92.0 centimeters. Further, in a particular embodiment, the width **210** of the base **202** is 45.0 centimeters. Additionally, in a particular embodiment, the height **212** of the base **202** is 34.0 centimeters. Accordingly, the DMA server **200** has a total volume of approximately 140,760 centimeters cubed and a footprint area of approximately 4,140 centimeters squared. Further, in a particular embodiment, the DMA server **200** weighs approximately 48 kilograms (kg). As such, in a particular embodiment, the DMA server **100** has a total volume that is less than 150,000 centimeters cubed, a footprint area that is less than 5,000 centimeters squared, and a weight that is less than 50.0 kilograms.

FIG. 3 illustrates another alternative embodiment of a distributed mobile architecture (DMA) server that is generally designated **300**. As depicted in FIG. 3, the DMA server **300** includes a housing **302** that has a length **304**, a width **306**, and a height **308**. Additionally, the housing **302** can be formed with a first vent **310** and a second vent **312**. In a particular embodiment, the vents **310**, **312** permit air exchange with the interior of the housing **302** of the DMA server **300** and facilitate cooling of the electronic components of the DMA server **300** within the housing **302**.

6

As shown in FIG. 3, at least one side of the housing **302** is formed with a rib **314** to enable the DMA server **300** to be slid into a server rack (not shown). Further, the DMA server **300** includes a clip **316** that is coupled to the housing **302** via a fastener, e.g., a bolt. The clip **316** can be engaged with a server rack (not shown) to prevent the DMA server **300** from unintentionally sliding out of the server rack (not shown).

In a particular embodiment, the length **304** of the housing **302** is approximately 76.2 centimeters. Further, in a particular embodiment, the width **306** of the housing **302** is approximately 48.2 centimeters. Additionally, in a particular embodiment, the height **308** of the housing **302** is approximately 4.3 centimeters. Accordingly, the DMA server **300** has a total volume of approximately 15,756.5 centimeters cubed and a footprint area of approximately 3,672.9 centimeters squared. Further, in a particular embodiment, the DMA server **300** weighs approximately 17.7 kilograms (kg). Also, in a particular embodiment, the DMA server **300** is stackable in order to support various capacity requirements. As such, in a particular embodiment, the DMA server **100** has a total volume that is less than 16,000 centimeters cubed, a footprint area that is less than 4,000 centimeters squared, and a weight that is less than 20.0 kilograms.

The description of embodiments of DMA servers with reference to FIGS. 1-3 are provided for illustration, not limitation. DMA servers also may be embodied in any other suitable form. For example, as described further below, a DMA server may be incorporated within an orbiting satellite that communicates with DMA gateways and other devices via satellite and ground-based communication networks.

FIG. 4 illustrates a non-limiting, exemplary embodiment of a distributive and associated telecommunications system generally designated **400**. As depicted in FIG. 4, the system **400** includes four cellular coverage sites **402**. Each coverage site **402** includes an antenna **404**. In one embodiment, the antenna **404** is connected to a transceiver belonging to a base transceiver station (BTS) and the BTS is a 3-sector BTS. FIG. 4 also indicates that a distributed mobile architecture (DMA) server **406** (abbreviated in FIG. 4 and figures as "DMAS") can be connected to each antenna **404**. In one embodiment, each DMA server **406** is physically and directly connected to its respective antenna **404**, e.g., by a wire or cable **408**. Further, in an illustrative embodiment, the DMA servers **406** can be any of the DMA servers shown in FIG. 1, FIG. 2, and FIG. 3.

As illustrated in FIG. 4, each DMA server **406** is interconnected with the other DMA servers **406** via an Internet protocol network **410**. As such, there exists a peer-to-peer connection **412** between each DMA server **406** in the system **400**. As described in detail below, the DMA servers **406** can handle telephony traffic that is communicated at each antenna **404**. For example, the DMA servers **406** can switch and route calls received via each antenna **404**. Additionally, the DMA servers **406** can hand-off calls to each other as mobile communications devices move around and between the cellular coverage sites **402**. The DMA servers **406** can communicate with each other via the IP network **410** and can further transmit calls to each other via the IP network **410**. It should be understood that more than four cellular coverage sites **402** can be included in the system and that the inclusion of only four cellular coverage sites **402** in FIG. 4 is merely for clarity and explanation purposes.

Within the distributed and associative telecommunications system **400** the controlling logic can be distributed and decentralized. Moreover, the wireless coverage provided by the disclosed system **400** is self-healing and redundant. In other words, due to the interconnectivity via the IP network **410**, if

one or more of the DMA servers **406** loses powers, fails, or is otherwise inoperable, telephony traffic handled by the inoperable DMA server **406** can re-routed to one of the remaining operable DMA servers **406**. Additionally, user data stored in a database, e.g., a home locator resource (HLR) or a visitor locator resource (VLR), can be distributed equally and fully among all of the DMA servers **406**. It can also be appreciated that new cellular coverage sites can be easily added to the system **400** as the demand for users increases. Specifically, a DMA server can be deployed as described below, connected to an antenna, connected to the IP network, and activated to provide cellular coverage in a new area.

FIG. **5** shows an exemplary, non-limiting, detailed embodiment of a DMA server, e.g., one of the DMA servers **406** described in conjunction with FIG. **4**. Further, any of the DMA servers **100**, **200**, **300** shown in FIG. **1**, FIG. **2**, and FIG. **3** can include the components depicted in FIG. **5** and described herein.

In a particular embodiment, the DMA server **406** is essentially a processor, or computer, having a housing and a computer readable medium **500** that is disposed therein. A power supply **502** can also be disposed within the housing of the DMA server **406** in order to provide power to the DMA server **406**. The power supply **502** can be a rechargeable battery disposed within the DMA server **406** or it can be external to the DMA server **406**, i.e., a standard power outlet. Moreover, a cooling system **504**, e.g., a fan with a thermostat, can be within the DMA server **406** in order to keep the DMA server **406** from overheating. In an alternative embodiment, the DMA server **406** can be a single board processor that does not require a fan.

As depicted in FIG. **5**, the DMA server **406** may include a mobile switching center (MSC) module **506** and a base station controller (BSC) module **508** embedded within the computer readable medium **500**. In an exemplary, non-limiting embodiment, the MSC module **506** can include a gatekeeper (GK) **510** that is connected to several gateways. For example, a circuit gateway (CGW) **512** can be connected to the GK **510** and can provide connectivity to an integrated services digital network/public switched telephone network (ISDN/PSTN) interface **514**. The CGW **512** can provide a circuit switched to packet data conversion. In an exemplary, non-limiting embodiment, the PSTN portion of the ISDN/PSTN interface **514** can be an inter-office interface that uses the Bellcore industry standard ISDN user part (ISUP) signaling on a signaling system seven (SS7) link set. Moreover, the voice trunks on this interface can be timeslots on a T1 connection. Inbound and outbound voice calls can be supported on the ISDN portion of the ISDN/PSTN interface **514**.

As further illustrated in FIG. **5**, a packet data server node (PDSN) gateway **516** for CDMA, or a Gateway GPRS Support Node (GGSN) for Global System for Mobile Communication (GSM), and a Session Initiation Protocol (SIP) gateway **518** can also be connected to the GK **510**. The PDSN gateway **516** and the SIP gateway **518** can provide connectivity to an IP interface **520**. Further, the PDSN gateway **516** or a GGSN can establish a reverse tunnel with the PDSN or GGSN gateway **516** using generic routing encapsulation (GRE). Moreover, the PDSN gateway **516**, or GGSN, can implement the Pseudo Random Function (PRF)/Foreign Agent (FA) functionality of the DMA server **406** which supports mobile IP functions.

FIG. **5** further shows an SS7 gateway **522** that provides connectivity to an American National Standards Institute 41 (ANSI-41) and GSM Mobile Application Part (MAP) interface **524**. In a particular embodiment, the ANSI-41 interface can be an SS7 TCAP/SCCP interface on the same SS7 link set

used for ISUP signaling. The same SS7 point code can be used to identify the DMA server **406** in the ANSI-41 network. The ANSI-41 interface can be used for roamer registration. Further, in an exemplary, non-limiting embodiment, the GSM MAP interface can be an SS7 TCAP/SCCP interface on the same SS7 link set used for ISUP signaling. It can be appreciated that there are different protocols of MAP from MAP/B to MAP/I, but in the illustrative embodiment, the different MAP/x protocols are not stacked—they are used independently. As described with reference to FIG. **11**, the SS7 interface may be included in either the DMA server **406** or the DMA gateway **1102**.

As depicted in FIG. **5**, a media gateway **526** can also be coupled to the GK **510**. In an exemplary, non-limiting embodiment, the media gateway **526** can include cellular transcoders, one or more intranet gateways, conferencing bridges, and group calling functionality. Further, an authentication, authorization, and accounting (AAA) module **528** can be coupled to the GK **510**. In an exemplary, non-limiting embodiment, there are three levels of authentication management. The highest level is for administration, the mid-level is for operations, and the lowest level is for normal users. The functions of the AAA module **528** can be included in the user level.

In an exemplary, non-limiting embodiment, the GK **510** can act as an AAA server and a feather server to support advanced supplementary service, short message service, etc. Moreover, the GK **510** can act as a call manager and can support ISUP and PSTN function calls. Additionally, the GK **510** can act as a signal gateway, e.g., IP to SS7 inter-working, ISUP, GSM MAP or ANSI-41 to PSTN and ANSI-42/GSM. The GK **510** can also function as a data call server.

As illustrated in FIG. **5**, the BSC module **508** includes a cellular radio network controller (CRNC) **530** and a cellular selection/distribution unit (CSDU) **532** that are connected to a call protocol controller (CPC) **534**. In turn, the CPC **534** can be connected to a plurality of base transceiver stations (BTSs) **536**. Specifically, the DMA server **406** includes a BTS interface **538** at the CPC **534** that can be physically and directly connected to the BTSs **536**. The CRNC **530** can provide cellular radio resource management and cellular call control. The CSDU **532** can provide Fundamental Channel (FCH) soft handoff and distribution, Link Access Control (LAC) processing for inband signaling, multiplexer (MUX) functions, and centralized power control. Further, the CPC **534** can convert a T1 or E1 message or ATM interface to a data packet message. In a particular embodiment, each BTS **536** supports signals and traffic up to the front point of the CPC **534**, e.g., up to the BTS interface **538**. Further, in a particular embodiment, the CRNC **530**, the CPC **534**, the CSDU **532** and the OAMP **540** can perform one or more of the functions of legacy Base Station Controllers (BSC).

In an exemplary, non-limiting embodiment, the BTS interface **538** can be an IS-95A OR IS-2000 interface over E1 or ATM, or the BTS interface **538** can be a GSM BTS interface using MAP or customized application for mobile network enhanced logic (CAMEL). In an illustrative embodiment, the CPC **534** can be connected to one or more BTSs **536**. FIG. **5** further shows that the BSC module **508** includes an operations, administration, maintenance, and provisioning (OAMP) module **540**. In an exemplary, non-limiting embodiment, the OAMP module **540** can use simple network management protocol (SNMP) for operations interfaces. Further, the OAMP module **540** can include a JAVA user interface. The OAMP module **540** can also include a software agent that is assigned to each component within the DMA server **406**.

The agents independently monitor their respective components. Moreover, each agent can provision its respective component.

When deployed in a network, such as illustrated in FIG. 4, embodiments of DMA servers are configured to handle the handing off of communications when, for example, a mobile device passes from a coverage site **402** (FIG. 4) covered serviced by one DMA server **406** to another coverage site **402** serviced by another DMA server **406**. As previously described, the DMA servers **406** participate in an IP network **410** through which the communications are routed between the DMA servers **406**. However, in not all cases will the DMA servers **406** be able to participate as peers in an IP network **410**. For example, if one or more of the coverage sites **402** are in rural locations or other locations remote from other coverage sites **402**, there may not be access to the IP network **410** in the remote coverage sites **402**. Accordingly, embodiments of the present disclosure describe DMA gateways to enable DMA servers to communicate with one another when one or more of the DMA servers cannot participate directly in the IP network. In addition, embodiments of the DMA gateways also enable legacy networks and devices participating in the legacy networks to communicate with devices serviced by one or more of the DMA servers as further described below.

Because of the mobility of various forms of the DMA servers and devices that may communicate via these servers, as well as the DMA gateways described below, the communications network accounts for the movement of these devices. In other words, as the devices move, information regarding the accessibility of these devices and how communications are routed among them is dynamic. Thus, even when such devices move during the course of a communication, information pertaining to the routing of the communication is updated to support continuation of the communication.

FIG. 6 illustrates a network **600** that includes a first DMA gateway (abbreviated as “DMAG” in FIG. 6 and other figures) **602** and a second DMA gateway **604** that communicate with each other over a DMA gateway network **606**. The DMA gateway network **606** may include a dedicated wired or wireless communication medium or be included within a network carrying other communications. The second DMA gateway **604** communicates with a legacy network that, for example, includes a public switched telephone network **610** that services communication with wired, landline devices such as landline telephone **612**. The DMA gateway also may enable communication with public IP networks that enable data communications, Voice over Internet Protocol (VoIP) communications, and other communications, as well as other types of legacy networks. Although a pair of DMA gateways **602** and **604** and a single legacy network **610** are shown in FIG. 6, any number of DMA gateways and legacy networks may participate in the network **600**.

In addition to the DMA gateways **602** and **604** and the legacy network **610**, the network **600** includes two groups of DMA servers in which the DMA servers communicate with each other over separate private IP networks. For example, in a first group communicating via a first private IP network **620**, three DMA servers **622**, **624**, and **626** communicate with each other. In a second group communicating via a second private IP network **640**, three DMA servers **642**, **644**, and **646** communicate with each other. Two different groups each including three DMA servers are shown for illustration. However, it will be appreciated that any number of groups of DMA servers could communicate with each other within each of the groups, and any number of groups could be bridged using

DMA gateways as described below to enable communications between devices associated with different DMA servers in different groups.

Each of the DMA servers may service a plurality of voice and/or data communications devices. For example, a first DMA server **622**, through an associated wireless transceiver, may service a plurality of communications devices such as a first wireless telephone device **632**. As previously described with reference to FIG. 4, the first wireless telephone device **632** may communicate with devices serviced by other DMA servers that participate in the first private IP network **620**. Thus, for example, the first wireless telephone device **632** would be able to engage in voice and/or data communications with a second wireless telephone device **634** serviced by a second DMA server **624**. Also, it should be appreciated that the second wireless telephone device may communicate with other devices, such as a third wireless telephone device **636** that is serviced by a same DMA server, such as the second DMA server **624**. Although the DMA servers in FIG. 6 are only shown servicing wireless telephone devices, it should be appreciated that other devices, such as computers and other communication devices also may participate in the network **600** by communicating through the DMA servers.

As shown in FIG. 6, the groups of DMA servers communicating via the two private IP networks **620** and **640** are separate networks. The wireless telephone devices **632**, **634**, and **636** serviced by DMA servers **622** and **624** participating in the first private IP network **620** do not have a network connection with any of the DMA servers **642**, **644**, and **646** that communicate with each other via the second private IP network. Thus, a fourth wireless telephone device **652** in communication with a fourth DMA server **642** can communicate with a fifth wireless telephone device **654** serviced by a fifth DMA server **644** because the DMA servers **642** and **644** can communicate with each other via the second private IP network **640**. Similarly, the sixth wireless telephone device **656** and the seventh wireless telephone device **658** can communicate with each other through the sixth DMA server **646** with which each communicates and each can communicate with the other wireless telephone devices **652** and **654** serviced by the other DMA servers **642** and **644** participating in the second private IP network. However, without a bridge between the first private IP network **620** and the second private IP network **640**, neither the DMA servers nor the wireless telephone devices serviced by each of the private IP networks **620** and **640** can communicate with devices serviced by the other private IP network. Similarly, neither the DMA servers nor the wireless telephone devices serviced by each of the private IP network **620** and **640** can communicate with the public switched telephone network **610** or any of the devices, such as the landline telephone device **612**, serviced by the public switched telephone network **610**.

Embodiments of the present disclosure enable devices on separate networks to communicate with each other via DMA gateways that bridge separate network and communications systems. In the example of FIG. 6, the first private IP network **620** communicates with the first DMA gateway **602** and the second private IP network **640** communicates with the second DMA gateway **604**. The DMA gateways **602** and **604** are configured to route communications from one private IP network to another and the DMA gateways **602** and **604** are in communication with each other via the DMA gateway network **606**. As a result, the DMA gateways **602** and **604** can route communications from the DMA servers **622**, **624**, and **626** and the devices they service to the DMA servers **642**, **644**, and **646** and the devices they service and vice versa. Also, because the second DMA gateway is coupled with the second

public switched telephone network **640**, the wireless telephone devices **652**, **654**, **656**, and **658** and other devices serviced by the DMA servers **642**, **644**, and **646** can communicate with the landline telephone device **612** and other devices serviced by the public switched telephone network **610**. In short, the DMA gateways can provide communications between wireless devices serviced by associated DMA servers and wired or wireless devices serviced by legacy networks coupled with the DMA gateways.

To facilitate communications between devices serviced by different networks, the DMA gateways **602** and **604** maintain information identifying the devices that each services. For example, when the first wireless telephone device **932** initiates a communication to the fourth wireless telephone device **952**, the first DMA gateway **602** accesses data identifying what other DMA gateway, if any, services the fourth wireless telephone device and which DMA server or other network or device associated with the first DMA gateway services the targeted fourth wireless telephone device **952**. DMA gateways provide information to one another regarding the communications networks they service by exchanging register data describing the networks they service. The register data describes devices for which the networks they service are the home network as well as for what devices are visiting on their networks. This information is exchanged directly between the DMA gateways or through a central database described further below with reference to FIG. **10**.

A DMA server may associate itself with different DMA gateways. For example, as described with reference to FIGS. **1** and **2**, a DMA server may include a mobile device that is easily moved from one place to another. A mobile DMA server that communicates wirelessly with a private IP network and the DMA gateway servicing that private IP network may move out of communications range of a DMA gateway with which it was previously associated into communications range with another DMA gateway. For further example, for purposes of traffic management, fault tolerance, or other reasons, it may be desirable to reassociate a DMA server previously associated with one DMA gateway to another DMA gateway. This reassociation may be initiated manually or automatically by the DMA server, the DMA gateway, or any combination thereof. Thus, for example, the fourth DMA server **642** may be reassociated with the first private IP network **620** and the first DMA gateway **602** servicing the first private IP network **620** as shown by the dashed line **660** in FIG. **6**. Because the DMA gateways **602** and **604** bridge the private IP networks **620** and **640**, devices serviced by the fourth DMA server **642**, such as the fourth wireless telephone device **652** may continue to communicate with the wireless telephone devices **654**, **656**, and **658** serviced by the DMA servers **644** and **646** associated with the second private IP network **640**.

The DMA gateways and DMA servers can be arrayed in any number of ways to facilitate the deployment and proliferation of communications networks. For example, FIG. **7** illustrates a network **700** that includes satellite-based DMA gateways including a first satellite-based DMA gateway **702** and a second satellite-based DMA gateway **704**. The satellite-based DMA gateways **702** and **704** are placed in orbits suitable to enable communications with ground-based private IP networks **720** and **740** and a ground-based legacy network **710**. The satellite-based DMA gateways **702** and **704** communicate with each other via a satellite communications network **706**. The second satellite-based DMA gateway **704** communicates with a legacy network, such as a public switched telephone network **710**, over a communications uplink **714** via the same satellite communications network

706 through which the satellite-based DMA gateways **702** and **704** communicate or another uplink communications medium. The satellite-based DMA gateways **702** and **704** communicate with private IP networks **720** and **740** that may include ground-based private IP networks, via the same satellite communications network **706** or other uplink communications media. An advantage of including satellite-based DMA gateways is the ability to bridge DMA servers or groups of DMA servers with one another even though the DMA servers or groups of DMA servers may be disposed remotely from each other where ground-based DMA gateways or ground-based communications media between the DMA servers are overtaxed, unreliable, unavailable, or otherwise undesirable.

Using the satellite-based DMA gateways **702** and **704**, communications between the DMA servers, the devices they serve, and the legacy network operates in a similar manner to the communications between devices as described with reference to FIG. **6**. A first group of DMA servers **722**, **724**, and **726** communicate via a first private IP network **720**. A first wireless telephone device **732** in communication with a first DMA server **722** is able to communicate with a second wireless telephone device **734** in communication with a second DMA server **724** via the first private IP network **720**. Further, the first wireless telephone device **732** is enabled, via the first DMA server **722** and the first private IP network **720**, to communicate with the first DMA gateway **702**. Then, via the satellite communications network **706**, the first DMA gateway **702** is able to communicate with the second DMA gateway **704** to enable communications with devices served by the second private IP network **740**. Thus, the DMA gateways **702** and **704** allow the first wireless telephone device **732** to communicate with a third wireless telephone device **762** even though the wireless telephone devices **732** and **762** participate in separate private IP networks **720** and **740**. In addition, because the second DMA gateway **704** is in communication with both the second private IP network **740** and the public switched telephone network **710**, the second DMA gateway **704** enables mobile-to-land communications between third wireless telephone device **762** and a wired landline device **712**. The use of satellite-based DMA gateways **702** and **704** enables this communication even a vast distances separate the communication devices and there are little or no land-based communications networks between the devices.

FIG. **8** illustrates a communications network **800** in which, instead of utilizing satellite-based DMA gateways, employs a ground-based DMA gateway **830** facilitating communications between satellite-based DMA servers **810** and **820**. In areas where, for example, a ground-based DMA server cannot be employed or the distance between wireless communication devices **812** and **814** is so large that one or more DMA servers may not be able to effectively service the wireless communication devices **812** and **814**, it may be desirable to enable communications with the deployment of satellite-based DMA servers such as DMA servers **810** and **820**. In such a case, the wireless communications devices **812** and **814** may include wireless satellite communications devices or other devices with access to a satellite uplink communications medium. As in the case of DMA servers previously described, a first wireless communications device **812** in communication with a first DMA server **810** may wirelessly communicate with a second wireless communications device **814** is also in communication with the first DMA server **810**.

In addition, because the first DMA server **810** is in communication with a ground-based DMA gateway **830** via a suitable uplink communications medium **840**, the first DMA server **810** is able to route communications between the

devices it serves and other devices in communication with the DMA gateway **830**. For example, the DMA gateway **830** is in communication with a first ground-based DMA server **850** that services a first wireless telephone device **852**. As a result, the wireless communications devices **812** and **814** are able to communicate with the first wireless telephone device **852**. Similarly, the DMA gateway **830** also is in communication with a private IP network **880** that provides communications between the second satellite-based DMA server **820** and two ground-based DMA servers **860** and **870**. As a result, the DMA gateway **830** enables communications between the wireless communications devices **812** and **814** serviced by the first satellite-based DMA server **810**, the first wireless telephone device **852** serviced by the ground-based DMA server **850**, a second wireless telephone device **862** serviced by a second ground-based DMA server **860**, a third wireless telephone device **872** serviced by a third ground-based DMA server **870**, and any devices (not shown in FIG. **8**) serviced by the second satellite-based DMA server **820**. In addition, if the DMA gateway **830** were in communication with one or more legacy networks, the DMA gateway **830** could enable communications between devices serviced by the legacy networks and devices serviced by the DMA servers **810**, **820**, **860**, and **870** in communication with the DMA gateway **830**.

FIG. **9** illustrates a communications network **900** illustrating how a communications network may include a combination of satellite-based and ground-based DMA servers and satellite-based and ground-based DMA gateways. Embodiments of the present disclosure are not restrictive to including only ground-based or satellite-based DMA gateways were DMA servers and thus provide flexibility in creating and proliferating communications networks based on the communications needs for which the network is deployed.

A first satellite-based DMA server **910** communicates with wireless communications devices **912** and **914**. The first satellite-based DMA server **910** also is in communications a satellite communications network **940** and a private IP network **950**. Via the satellite communications network **940**, first the satellite-based DMA server is able to communicate with a satellite-based DMA gateway **930** to, for example, enable communications between devices served by a first ground-based DMA server, such as a first wireless telephone **992**. Via the private IP network **950**, the satellite-based DMA server **910** also is able to communicate with other DMA gateways, such as a first ground-based DMA gateway **960** and a second ground-based DMA gateway **970**. Thus, the devices served by the satellite-based DMA server **910** would be able to communicate with devices in communication with the ground-based DMA gateways **960** and **970**, such as the second wireless telephone device **974** that is serviced by a second ground-based DMA server **972** in communication with the second ground-based DMA gateway **970**. In sum, as described in the particular illustrative embodiments depicted in FIGS. **6-9**, satellite-based or ground-based DMA servers and satellite-based or ground-based gateways can be deployed as desired to enable communications between various communications devices.

To facilitate communications between devices serviced by different networks, the DMA gateways maintain information identifying the devices that each services. For example, a user of a wireless telephone device serviced by a first DMA server may send a communication to the user of the target wireless telephone device that is serviced by a second DMA server. The first and second DMA servers both are in communication with a DMA gateway that enables communications between the devices serviced by the different DMA servers. The DMA gateway is configured to route the communications by access-

ing information indicating which DMA servers provide service to which wireless devices. The DMA gateway may maintain the information locally in the DMA gateway or access information maintained in a central register accessible to the DMA gateway. When the information is maintained locally in the DMA gateway, DMA gateways in the network provide information to one another regarding the devices they service by exchanging register data describing the devices they service. The register data describes devices for which the networks they service are the home network as well as for what devices are visiting on their networks. This information is exchanged directly between the DMA gateways or through a central database described further below with reference to FIG. **10**.

FIG. **10** shows a network **1000** including a pair of DMA gateways **1010** and **1050** that facilitate communications between devices on different types of networks. A first DMA gateway **1010** communicates with a plurality of DMA servers **1012**, **1014**, and **1016** and a plurality of legacy networks **1020**, **1030**, and **1040**. As described below with reference to FIG. **11**, the DMA gateway **1010** includes interfaces configured to communicate with a PSTN **1020**, a mobile switching center (MSC) **1030** such as used by wireless telephones and communications devices, and a public IP network **1040**. The DMA gateway **1010** thus permits communication between devices serviced by the DMA servers **1012**, **1014**, and **1016** and devices serviced by the associated legacy networks **1020**, **1030**, and **1040**.

In addition, the DMA gateway **1010**, through the satellite communications network **1080** or other DMA gateway network, communicates with other DMA gateways to support communications between the devices serviced by different DMA gateways. For example, the second DMA gateway **1050** is associated with a private IP network **1060** that services a plurality of DMA servers **1052**, **1054**, **1056** and the devices they serve. Thus, through the DMA gateways **1010** and **1050**, devices serviced by one of the DMA servers **1012**, **1014**, and **1016** or devices serviced by the legacy networks **1020**, **1030**, and **1040**, can communicate with devices serviced by the DMA servers **1052**, **1054**, and **1056** or other networks serviced by the second DMA gateway **1050**. The private IP network **1060** also includes a central register database **1070** that maintains information serviced by DMA gateways and DMA servers within the network **1000**. The operation of this central register database **1070** is described further below.

As shown in FIG. **10**, one or more of the DMA servers **1012**, **1014**, and **1016** may communicate directly with a respective DMA gateway, such as DMA gateway **1010**, through a satellite uplink or other communications medium. Alternatively, one or other DMA servers **1052**, **1054**, and **1056** may communicate with a DMA gateway, such as DMA gateway **1050**, via a private IP network **1060** in which the DMA servers **1052**, **1054**, and **1056** and the DMA gateway **1060** participate. When a DMA server communicates with a DMA gateway over a private IP network, the respective DMA server and DMA gateway may communicate with each other by transmitting IP packet data over the private IP network. On the other hand, when the DMA server communicates with the DMA gateway via a different medium, the DMA server and DMA gateway may communicate with each other according to the protocol of the available medium.

In the networks of FIGS. **6-10**, embodiments of DMA gateways exchange communications information identifying devices serviced by one or more DMA servers or other communications networks that the DMA gateways service. When a DMA gateway detects that it is in communications range

with one or more DMA servers, the DMA gateway sends communications information from the DMA servers or other communications networks to one or more other DMA gateways or to a central database, such as the central register database **1070**. The communications information may include a notification of what DMA server or servers with which the DMA gateway is in communication. As DMA gateways move between communications ranges of various DMA servers or vice versa, the DMA gateways may send additional notifications or other information to update the previously-communicated communications information as to what communications networks are accessible to the various DMA gateways.

The communications information, in one embodiment, includes register information, such as home location register (HLR) information and visitor location register (VLR) information maintained by the DMA servers or other communications networks. As described with reference to FIG. 1 and FIG. 2, because a DMA server may include a portable or mobile device, the DMA server information also may identify whether the DMA gateway is a home gateway for the DMA server or whether the DMA server is temporarily registered with the DMA gateway in a visitor DMA register.

When another DMA gateway receives the DMA server information from a first DMA gateway, a second DMA gateway stores the DMA server information in a home DMA register in which the second DMA gateway also stores information regarding the devices it services. The second DMA gateway receives a communication from one of the devices it services targeted for a wireless device that is serviced by the first DMA gateway. The second DMA gateway then routes the communication via a DMA gateway network to the first DMA gateway. The first DMA gateway, using its own home DMA register storing information about the devices it services, then directs the communication to the network and/or DMA server that services the targeted communications device.

When the DMA gateway receives DMA server information about one or more DMA services associated with the DMA gateway or information about other networks the DMA gateway services, the DMA gateway may provide the DMA server information to other DMA gateways in a number of ways. For example, the DMA gateway may send a notification to other DMA gateways that it has received the DMA server information and that the DMA server information can be retrieved from the DMA gateway or, as described below, from a central database. The DMA server information is then transmitted to other DMA gateways in response to queries from one or more gateways requesting the DMA server information. Alternatively, the DMA gateway may automatically send the DMA server information to other gateways upon receiving the DMA server information.

Instead of or in addition to sending the DMA server information to other DMA gateways, the DMA gateway may send the DMA server information to a central database as shown in FIG. 10. Then, for example, when a DMA gateway such as DMA gateway **1010** is in communications range of a DMA server such as DMA server **1012**, the DMA server information is sent to the central register database **1070**. The DMA server information is sent from the DMA gateway **1010** via the satellite communications network **1080** to the DMA gateway **1050** where the DMA server information is routed via the private IP network **1060** to the central register database. Thus, as DMA server networks and other networks are added to the system, the DMA gateway servicing each of these communications networks receives the communications information for the communications network and sends the communica-

tions information to the central register database **1070**. Then, other DMA gateways each can receive the new communications information from the central register database **1070**.

The new communications information may be automatically sent by the central register database **1070** via the DMA gateway **1050** that services the central register database. Alternatively, when new communications information is received, the DMA gateway receiving the communications information or the central register database **1070** may send a notification to other DMA gateways that the new information is available for retrieval.

FIG. 11 shows an operating environment **1100** including a plurality of networks serviced by a DMA gateway **1102**. The DMA gateway **1102** services networks through a plurality of interfaces configured to support different types of networks. The DMA gateway **1102** communicates with a private IP network **1104**, such as that used to communicate with one or more DMA servers and/or a central register database as shown in FIG. 7, via a data network interface **1106**. The DMA gateway **1102** communicates with the DMA gateway network, which in this example includes a satellite network **1108**, via a satellite network interface **1110**. In addition, the DMA gateway **1102** includes one or more interfaces that enable the DMA gateway **1102** to communicate with one or more legacy networks. For example, the DMA gateway **1102** communicates with a public switched telephone network (PSTN) or integrated services digital network (ISDN) **1112** via a PSTN/ISDN interface **1114**. The DMA gateway **1102** communicates with a public IP network **1116** via a public IP interface **1118** that enables the DMA gateway **1102** to, for example, exchange Internet data or voice over Internet protocol (VoIP) calls. The DMA gateway **1102** also communicates with a wireless network **1120** via a mobile device interface **1122**. The DMA gateway **1102** also communicates with an ANSI-41 network **1124** via an SS7 TCAP/SCCP interface **1126** operable to be used in ISUP signaling, DMA server identification, roamer registration, and other functions described with reference to the SS7GW interface **522** described with reference to FIG. 5.

One or more processors **1130** is coupled with the interfaces **1106**, **1110**, **1114**, **1118**, and **1122** and a memory device **1140**. The memory device **1140** may include one or more of a random access memory, including volatile and nonvolatile rewritable memory devices, a read-only memory, and data storage devices. The memory device **1140** maintains a plurality of software modules providing executable instructions to the processor **1130** to support for the functions of the DMA gateway **1102**. The modules include one or more gateway modules **1142** that include the operating system and basic control software that enables the processor **1130** to interact with its network interfaces. One or more conversion modules **1144** control the translation of data and data formats used by one of the networks to that of one or more other networks to which data is to be communicated. One or more routing modules **1146** provide instructions to the processor for routing communications between the appropriate interfaces. The routing instructions use information about the accessibility of devices through various servers, gateways, and networks. Thus, as information about a communication is received, routing instructions are provided indicating through which DMA gateways the communication is to be directed from its source to its destination.

One or more legacy network communications modules provide instructions for the processor **1130** to interact with each of the legacy communications network interfaces **1114**, **1118**, **1122**. One or more DMA detection modules **1152** provide instructions to the processor for detecting the pres-

ence of accessible DMA servers and integrating the servers into the DMA network. One or more register data management modules **1154** receive, maintain, and/or forward register data for various networks and devices. The one or more register data management modules **1154** are operably coupled with a community location register (CLR)/visitor location register gateway (VLR)/gateway (GW)/global title (GT) (collectively, CVGG) data storage **1160** to maintain register data for DMA servers and other networks that communicate through the DMA gateway **1102**. The register data stored by embodiments according to the present disclosure are described below with reference to FIGS. **9** and **10**.

The DMA gateway **1102** may be implemented in a number of forms. For example, the DMA gateway **1102** may be implemented as an orbiting satellite, as described with reference to FIGS. **6** and **7**. Alternatively, the DMA gateway **1102** may include either a fixed or portable ground station. The DMA gateways **1102** communicate with each other through a gateway network. In the example of FIGS. **6** and **7**, the gateway network includes a satellite communications network. However, if the DMA gateways include only ground-based stations, the gateway network may include a point-to-point network facilitated by microwave communications, optical or other cabled connections, or other types of communications systems. If the gateway network includes both orbiting and ground-based stations, the gateway network may include a combination of satellite-based and non-satellite based communications systems.

FIGS. **12** and **13** show tables depicting how communications information including register data is stored in the DMA gateways or a central register database. The tables in FIGS. **12** and **13** are a logical representation. The entries within the tables do not represent a single value as might be found, for example, in a single entry of a spreadsheet document. Instead, the entries within the rows and columns of the table represent a category of information stored within the table.

In the example of FIGS. **12** and **13**, representative data is shown for three DMA gateways and three DMA servers, although data for any number of DMA gateways and DMA servers participating in a DMA network may be included in register data tables. In this example, it is assumed that each DMA gateway is in communication with a respective DMA server designated with the same number, e.g., DMA gateway **1** is in communication with DMA server **1**, etc. FIG. **12** shows tables **1200** and **1250** representing the register data stored in each of DMA gateway **1** and DMA gateway **2**, respectively, while FIG. **10** shows a table **1000** representing the register data stored in a central register database for the three DMA gateways.

In the table **1200** for the DMA gateway **1**, three rows **1210**, **1212**, and **1214** store register data for each of the respective DMA servers, DMA server **1**, DMA server **2**, and DMA server **3**. In a CLR database column **1220**, CLR data is stored for each of the three DMA servers and, in a VLR database column **1222**, VLR data is stored for each of the three DMA servers. In DMAG **2** Community HLR database column **1224** and DMAG **3** Community HLR database column **1226**, the HLR data for each of the DMA servers is stored for DMA gateway **2** and DMA gateway **3**, respectively. In a Visitor DMA Server Register column **1228**, data is stored for one or more DMA servers that are temporarily registered with DMA gateway **1**.

In the table **1250** for the DMA gateway **2**, three rows **1260**, **1262**, and **1264** store register data for each of the respective DMA servers, DMA server **1**, DMA server **2**, and DMA server **3**. In a CLR database column **1270**, CLR data is stored for each of the three DMA servers and, in a VLR database

column **1272**, VLR data is stored for each of the three DMA servers. In DMAG **1** Community HLR database column **1274** and DMAG **3** Community HLR database column **1276**, the HLR data for each of the DMA servers is stored for DMA gateway **1** and DMA gateway **3**, respectively. In a Visitor DMA Server Register column **1278**, data for one or more DMA servers that are temporarily registered with DMA gateway **2**.

Referring to FIG. **13**, in the table **1300** for the central register database, three rows **1310**, **1312**, and **1314** store register data for each of the respective DMA servers, DMA server **1**, DMA server **2**, and DMA server **3**. In a DMA gateway **1** HLR database column **1320**, HLR data is stored for each of the three DMA servers. In a DMA gateway **1** VLR database column **1322**, VLR data is stored for each of the three DMA servers. In DMAG **1** Visitor DMA server register column **1324**, data is stored for one or more DMA servers that are temporarily registered with DMA gateway **1**. In a DMA gateway **2** HLR database column **1326**, HLR data is stored for each of the three DMA servers. In a DMA gateway **2** VLR database column **1328**, VLR data is stored for each of the three DMA servers. In DMAG **2** Visitor DMA server register column **1330**, data is stored for one or more DMA servers that are temporarily registered with DMA gateway **2**.

FIG. **14** shows a flow diagram **1400** of an exemplary process for routing communications using DMA gateways. In the example of FIG. **14**, a first DMA server comes in communications range or otherwise becomes accessible to a first DMA gateway while a legacy communications network becomes accessible to a second DMA gateway.

At **1402**, information is received at a first DMA gateway indicating the location of register data for a DMA server. This register data may be stored in another DMA gateway or a central register database. At **1404**, information is received indicating that a second DMA gateway is in communication with a legacy communications network. At **1406**, it is detected that the first DMA server is now in communications range of the first DMA gateway. At **1408**, the first DMA gateway receives the DMAS register data for the first DMA server from the location identified at **1402**. As previously described, this information may be automatically transmitted to the first DMA gateway when it comes within communications range of the first DMA server or the first DMA gateway may request the information from the location where it is stored.

At **1410**, information is received that relates to a data and/or voice communication placed by a mobile device associated with the first DMA server. The information indicates that the communication is directed or placed to a target device accessible via the legacy communications network. The accessibility of the legacy communications network to the second DMA gateway was previously identified to the first DMA gateway at **1404**. Thus, at **1412**, the communication information is routed from the first DMA gateway to the second DMA gateway. The process ends at **1414**. The process repeats indefinitely as desired to relay communications using the DMA gateways.

FIG. **15** shows a flow diagram **1500** of an exemplary process for routing communications to a DMA gateway depending on whether the DMA gateway communicates with a server through a private IP network or through another medium. At **1502**, routing instructions are received at a DMA server from a DMA gateway when the DMA server is in communication with the DMAG, such as when the DMA gateway comes within communications range of the DMA server. At **1504**, a communication is received at the DMA server from a mobile communications device via a wireless

transceiver coupled to the DMA server. At **1506**, it is determined whether the DMA server communicates with the DMA gateway via a private IP network. If so, at **1510**, packet data related to the communication is sent as packet data over the private IP network that is received by the DMA gateway via its private IP network interface. On the other hand, if it is determined at **1506** that the DMA server does not communicate with the DMA gateway via a private IP network, at **1512**, the information related to the communication is transmitted to the DMA gateway via another medium, such as a direct satellite uplink. The information related to the communication is thus received by the DMA gateway via a satellite communications network interface.

At **1514**, the communication is routed from the DMA gateway to the destination device. The communication is routed using information received and maintained by the DMA gateway as described, for example, in FIG. **14**. The process ends at **1516**. The process repeats indefinitely as desired to relay communications using the DMA gateways.

The above-disclosed subject matter is to be considered illustrative, and not restrictive, and the appended claims are intended to cover all such modifications, enhancements, and other embodiments, which fall within the true spirit and scope of the present invention. Thus, to the maximum extent allowed by law, the scope of the present invention is to be determined by the broadest permissible interpretation of the following claims and their equivalents, and shall not be restricted or limited by the foregoing detailed description.

What is claimed is:

- 1.** A method, comprising:
 - receiving at a first distributed mobile architecture (DMA) gateway communications information for a communications network accessible by a second DMA gateway, the communications information indicating one or more devices accessible by one of a DMA server and a legacy communications network, wherein the first DMA gateway and the second DMA gateway participate in a DMA gateway communications network;
 - storing the communications information in a home DMA register of the first DMA gateway;
 - receiving a communication at the first DMA gateway for a target device indicated by the communications information to be served by the second DMA gateway; and
 - routing the communication from the first DMA gateway to the target device by relaying the communication from the first DMA gateway to the second DMA gateway via the DMA gateway communications network.
- 2.** The method of claim **1**, wherein:
 - at least one of the first DMA gateway and the second DMA gateway includes a satellite-based DMA gateway; and
 - the DMA gateway communications network includes a satellite communications network.
- 3.** The method of claim **1**, wherein the DMA server includes one of:
 - a ground-based DMA server; and
 - a satellite-based DMA server.
- 4.** The method of claim **1**, wherein the communication includes at least one of:
 - a voice communication; and
 - a data communication.
- 5.** The method of claim **1**, wherein the legacy communications network includes one of:
 - a public switched telephone network (PSTN);
 - a wireless communications network serviced by mobile switching center (MSC);
 - a public internet protocol (IP) network; and

an American National Standards Institute 41 (ANSI-41) network.

6. The method of claim **1**, further comprising the first DMA gateway sending a notification to the second DMA gateway, the notification indicating that the communications information is stored at the first DMA gateway.

7. The method of claim **1**, further comprising, upon receiving the communications information, the first DMA gateway automatically sending at least a portion of the communications information to the second DMA gateway via the gateway communications network.

8. The method of claim **1**, further comprising, in response to receiving a query from the second DMA gateway for the communications information, the first DMA gateway sending at least a portion of the communications information to the second DMA gateway via the gateway communications network.

9. The method of claim **1**, wherein the communications information includes communications register data including at least one of:

- a portion of a community location register;
- a portion of home location register (HLR) data for the communications network; and
- a portion of visitor location register (VLR) data for the communications network.

10. The method of claim **9**, wherein the register data stored at the first DMA gateway indicates that the register data is for a DMA server temporarily registered in a visitor DMA register of the second DMA gateway.

11. The method of claim **1**, further comprising the first DMA gateway detecting the presence of the communications network within a communications range of the first DMA gateway.

12. The method of claim **11**, further comprising the first DMA gateway sending communications network information to the second DMA gateway indicating that the communications network is within the communications range of the first DMA gateway.

13. The method of claim **11**, further comprising the first DMA gateway sending communications network information to a central database indicating that the communications network is within the communications range of the first DMA gateway.

14. The method of claim **11**, further comprising the first DMA gateway receiving additional communications network information from the second DMA gateway indicating that the second DMA gateway detects the presence of an additional communications network within a communications range of the second DMA gateway.

15. The method of claim **1**, further comprising the first DMA gateway receiving a second notification from a central database, the second notification indicating that second register data is stored at the central database.

16. The method of claim **15**, further comprising the first DMA gateway detecting a second communications network in a service area of the first DMA gateway.

17. The method of claim **16**, wherein the first DMA gateway detects a private Internet Protocol (IP) network access point within a communications range of the first DMA gateway and wherein the first DMA gateway is adapted to communicate with the second communications network via the private Internet protocol (IP) network.

18. The method of claim **16**, wherein the first DMA gateway sends second communications information to the central database indicating that calls associated with the second communications network are accessible to the first DMA gateway.

21

19. The method of claim 18, wherein the first DMA gateway receives the second register data from the central database.

20. The method of claim 1, wherein the first DMA gateway receives the communications information from the second DMA gateway.

21. The method of claim 1, wherein the first DMA gateway receives the communications information from a central database.

22. A network communications system, comprising:
a first distributed mobile architecture (DMA) gateway including:

a first interface adapted to communicate with a legacy communications network;

a second interface adapted to communicate with a private Internet Protocol (IP) network;

a third interface adapted to communicate with a DMA gateway communications network; and

a server having logic adapted to:

receive legacy network information from a second DMA gateway, the legacy network information indicating that the legacy communications network is in a communications range of the second DMA gateway; and

forward information associated with a call received from a DMA server via the second interface to the second DMA gateway via the third interface;

wherein the call is placed to a destination device accessible via the legacy communications network.

23. The system of claim 22, wherein at least one of the first DMA gateway and the second DMA gateway comprises a satellite-based DMA gateway.

24. The system of claim 22, wherein at least one of the first DMA gateway and the second DMA gateway comprises a ground-based DMA gateway.

25. The system of claim 22, wherein the DMA server includes one of:

a ground-based DMA server; and

a satellite-based DMA server.

26. The system of claim 22, wherein the logic is adapted to receive DMA server register data from the DMA server indicating that a mobile communications device is accessible to the DMA server via a wireless transceiver coupled to the DMA server.

27. The system of claim 22, wherein the first DMA gateway communicates with a central database via the third interface, the central database storing register data associated with the DMA server.

28. The system of claim 22, wherein the first DMA gateway communicates with a central database via the second interface, the central database storing register data associated with the DMA server.

29. The system of claim 22, wherein the first DMA gateway and the second DMA gateway communicate via C-Band, Ku-Band, Ka-Band, L-Band, or any combination thereof.

30. The system of claim 22, wherein the gateway communications network comprises at least one of an IP network and a microwave network.

31. The system of claim 22, wherein the legacy communications network includes one or more of:

a public switched telephone network (PSTN);

a wireless network;

a public IP network; and

an American National Standards Institute 41 (ANSI-41) network.

22

32. The system of claim 22, wherein the DMA server is one of a plurality of DMA servers communicating with the first DMA gateway via the second interface.

33. A method of routing calls via a communications network, the method comprising:

receiving first routing instructions at a first distributed mobile architecture (DMA) server from a first DMA gateway when the first DMA server is in a first service area of the first DMA gateway, the first DMA gateway comprising a first orbiting satellite; and

sending a first call received at the first DMA server from a first mobile communications device via a wireless transceiver integrated with the first DMA server to the first DMA gateway via a private Internet Protocol (IP) network according to the first routing instructions;

wherein the first call is placed to a destination device accessible via a legacy communications network, the legacy communications network accessible via the first DMA gateway.

34. The method of claim 33, wherein the first DMA server is adapted to send the first call while being transported from a first location to a second location.

35. The method of claim 34, wherein the first DMA server receives second routing instructions from a second DMA gateway when the first DMA server moves into a second service area of the second DMA gateway, the second service area comprising the second location and the second DMA gateway comprising an orbiting satellite.

36. The method of claim 35, wherein the first DMA server sends a second call received at the first DMA server from the first mobile communications device to the second DMA gateway via the private IP network according to the second routing instructions.

37. The method of claim 36, wherein the second call is associated with a destination device accessible via the legacy communications network.

38. The method of claim 36, wherein the second call is associated with a second mobile communications device accessible to a second DMA server, the second DMA server accessible to the second DMA gateway via the private IP network.

39. The method of claim 35, wherein the first DMA server receives the second routing instructions from the second DMA gateway during the first call.

40. The method of claim 35, wherein the first DMA server sends first DMA server register data to the second DMA gateway in response to receiving the second routing instructions.

41. The method of claim 33, wherein the first DMA server receives second routing instructions from a second DMA gateway when the first DMA server leaves the first service area and enters a second service area of the second DMA gateway due to orbital motion of the first DMA gateway and the second DMA gateway, the second DMA gateway comprising an orbiting satellite.

42. A network communications system, comprising:
a distributed mobile architecture (DMA) server coupled to a wireless transceiver, the DMA server including:
a first interface adapted to communicate with a private Internet Protocol (IP) network;
a second interface adapted to communicate with a gateway communications network; and
a server having logic adapted to:

receive a call from a mobile communications device via the wireless transceiver; and

send call information related to the call to a DMA gateway;

23

wherein the call is placed to a destination device accessible via a legacy communications network, the legacy communications network accessible via the DMA gateway.

43. The system of claim **42**, wherein the logic is adapted to send the call information to the DMA gateway via the first interface according to routing instructions received at the DMA server from the DMA gateway.

24

44. The system of claim **42**, wherein the logic is adapted to send the call information to the DMA gateway via the second interface according to routing instructions received at the DMA server from the DMA gateway.

45. The system of claim **42**, wherein the logic is adapted to convert the call information to packet data when the call information is sent to the DMA gateway via the first interface.

* * * * *